

FPGA Mezzanine Card Connector (Low-Pin Count) : MC-LPC-10

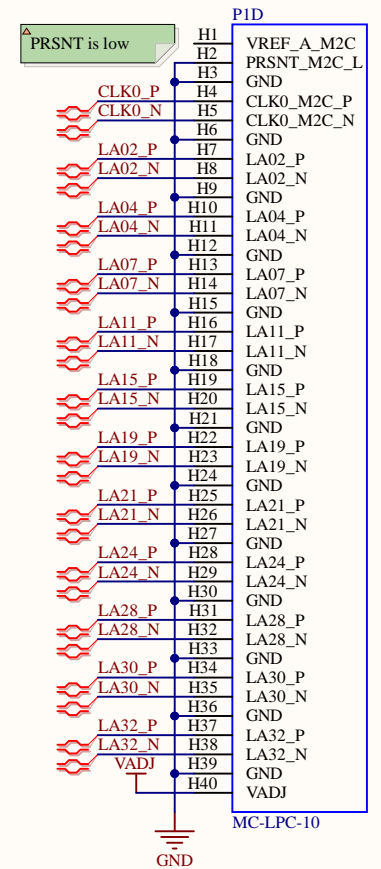

I2C EEPROM (256 Byte) for FRU information

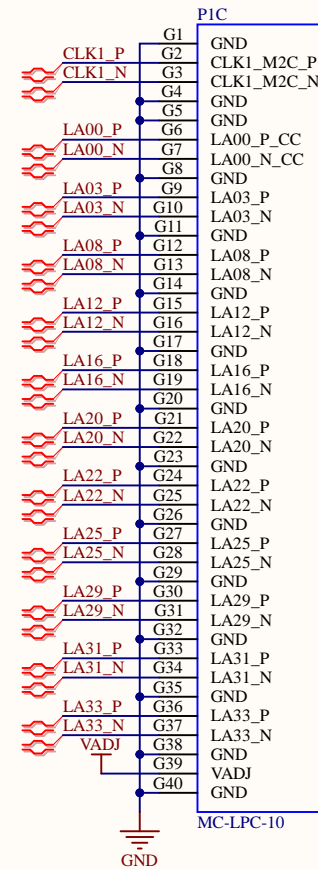
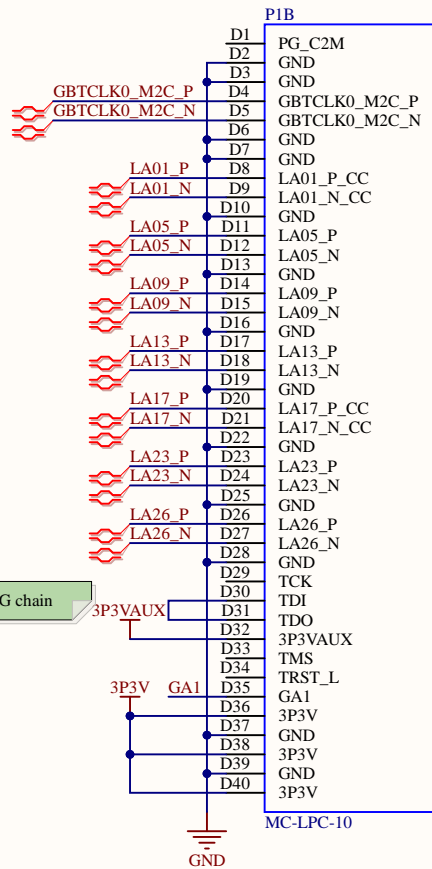
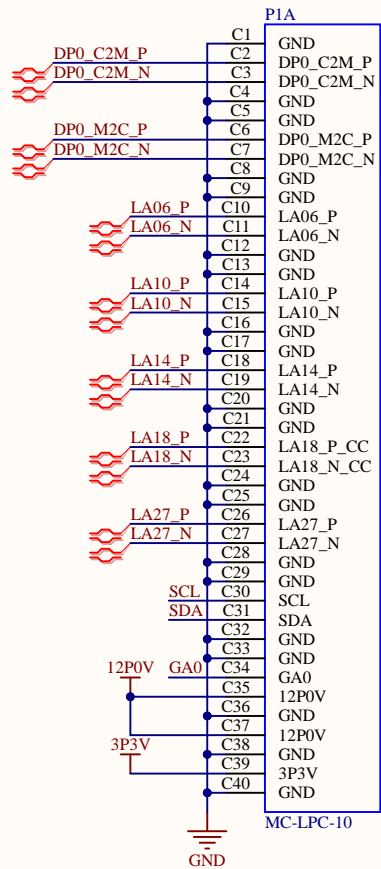
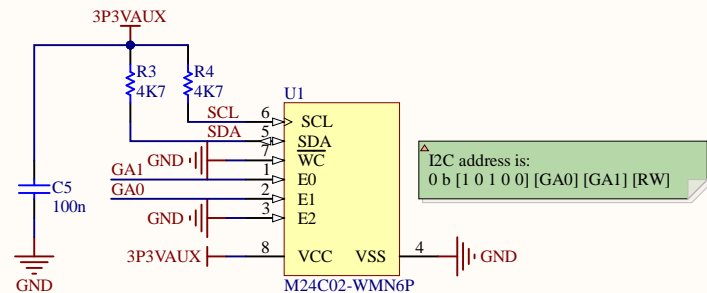

Mounting holes next to FMC connector

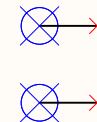

No connection on plated holes

Logos



Title: FMC MC-LPC-10 connector, I2C EEPROM (FRU information record), mounting holes, and logos

Project: FMC LPC Pin Header Board

Website: www.iamelectronic.com

Date: 02-NOV-2020

Engineer: PFH

Rev: A

Sheet: 1 / 2



Pin Header (2.54mm)

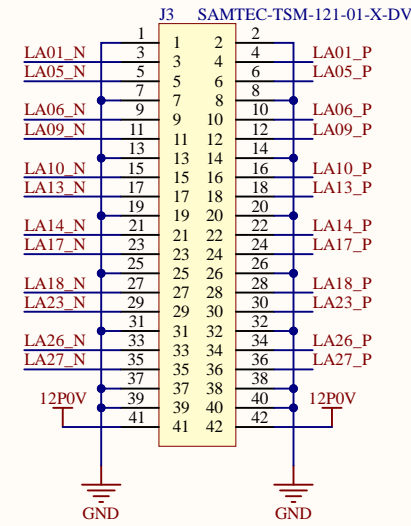
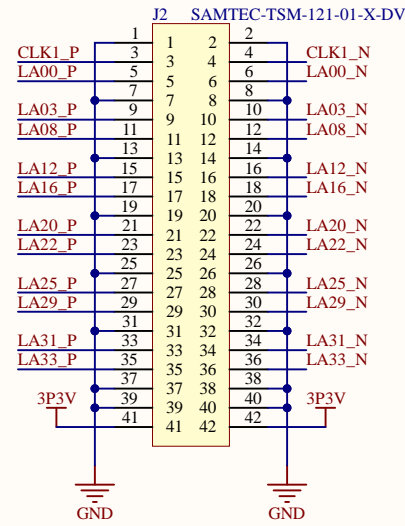
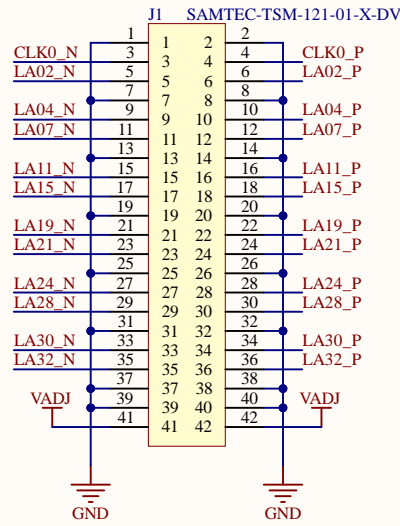

SMA Edge Connectors

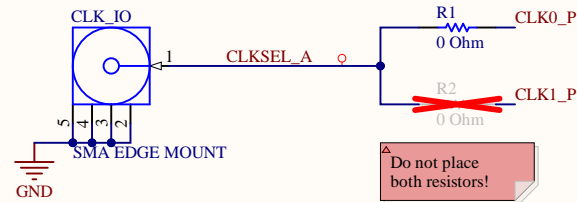

Clk is decoupled on carrier board

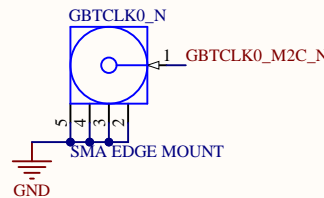
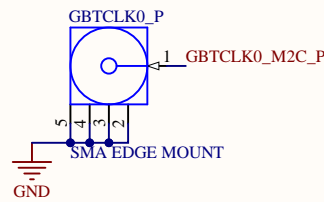

Data is decoupled on mezzanine board

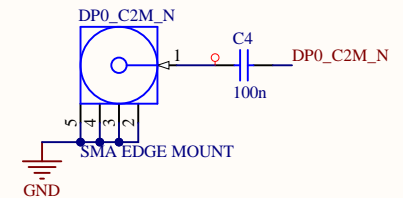
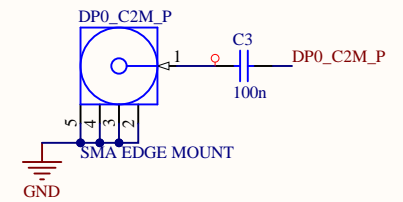
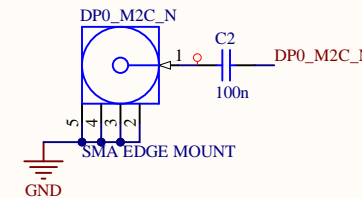
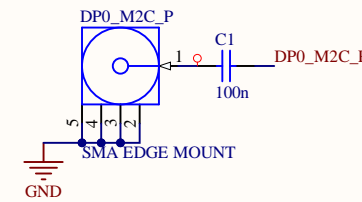

Title: 2.54mm Pin Header (3x 42 pos), and SMA jacks (7x)

Project: FMC LPC Pin Header Board

Website: www.iamelectronic.com

Date: 02-NOV-2020

Engineer: PFH

Rev: A

Sheet: 2 / 2

