

# Innomaker USB2CAN Device UserManual

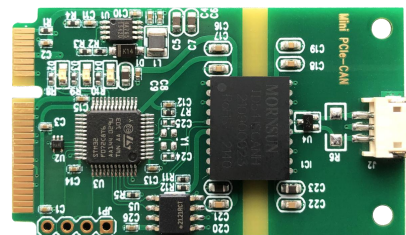

**Menu**

Innomaker USB2CAN Device UserManual.....	1
1. General Description:.....	4
2. Features.....	5
3. Technical Specification.....	6
3.1 USB2CAN modue and USB2CAN-Dev.....	6
3.2 USB2CAN-DEV.....	7
3.3 USB2CAN-C.....	8
3.4 USB2CAN-X2.....	9
3.5 MINIPCIE-CAN.....	10
4. Hardware Description.....	11
4.1 USB2CAN modue and USB2CAN-Dev.....	11
4.2 USB2CAN-C.....	13
4.3 USB2CAN-X2.....	15
4.4 MINIPCIE-CAN.....	19
5. Windows/Mac OS Ready-Made Tools.....	22
5.1 Open the USB2CAN tools.....	22
5.2 Scan For Devices.....	22
5.3 Setting The BandRate And Working Mode.....	23
5.4 Enable Device.....	24
5.5 Send/Receive Data.....	24
5.6 Windows Real Time Setting.....	25
5.7 Mac Os Double Open The USB2CAN Tool.....	25
6. Windows API.....	26
6.1 Dynamic Link Libraries.....	26
6.2 Structure.....	26
6.3 CallBack.....	27
6.4 Function.....	28
7. Mac Os API.....	32
7.1 Library.....	33
7.2 Document.....	33
8. Linux/Ubuntu/Raspbian.....	35
8.1 Run Test Demo.....	35
8.1.1 Preparatory work.....	36
8.1.2 Run can-utils Tool.....	37
8.1.3 Run C Demo.....	39
8.1.4 Run Python3 Demo.....	40
8.2 Software Description.....	41
8.2.1 Programming in C.....	41
8.2.2 Programing in Python3.....	44
9. BUSMASTER On Windows.....	46
9.1 Download and Install.....	46
<b>Support: <a href="mailto:support@inno-maker.com">support@inno-maker.com</a> <a href="https://github.com/INNO-MAKER/usb2can">https://github.com/INNO-MAKER/usb2can</a></b>	<b>2</b>
<b>Bulk Price: <a href="mailto:sales@inno-maker.com">sales@inno-maker.com</a></b>	

9.2 Using The Software.....	49
10. Error Frame.....	51
11. User Manual Version Descriptions.....	53

# 1. General Description:

USB2CAN device is a 'plug and play' and bi-directional port powered USB/PCIE to CAN converter which realizes long-distance communication between your Raspberry Pi/SBC/PC/laptop and other devices stably though CAN- Bus connection.

With small size and convenient operation, It's a cost-effective solution that are safe and reliable for all your data-conversion / device-protection applications for any experienced engineer interfacing to expensive industrial equipment yet simple enough for home use by an amateur hobbyist.

USB2CAN can also be applied to obtain the data of car via the OBD connector, but you need to configured and secondary development by yourself.

Support Linux system , It's a socket-can device in Linux, not need to install any driver and fully compatible with other socket-can software in Linux such as can-utils.

Support Mac OS version equal or above 10.11 and provide development library for help customer develop own applications.

Support Win7/Win8/Win10 and provide C#/C++/Python demo and dynamic link libraries for help customer develop own applications.

We provide five kinds of USB2CAN, the hardware appearance is different but the software ,firmware features are 100% same.



USB2CAN Module



USB2CAN-C



USB2CAN-DEV



USB2CAN-X2

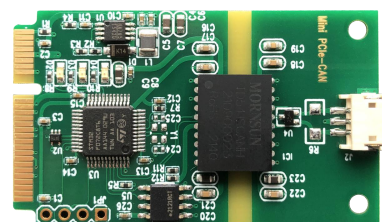

MINIPCIE-CAN

## 2. Features

1. The USB/MINIPCIE to CAN Converter Module compatible with all series Raspberry Pi/Jetson Nano/Tinker Board/any single board computer, desktop and laptop.
2. The USB CAN Module support Windows System, Mac OS and Linux, Raspbian(v5.4 kernel), Ubuntu.
3. Plug and Play USB CAN device. No external power required. Support wider CAN baud rate, from 20Kbps to 1Mbps can be programmed arbitrarily. Support for CAN bus 2.0A and 2.0B specification.
4. Provides 3000V/5000V voltage isolation and 2500V ESD isolated protection on signal pins. 120 Ohm resistor selectable jumper feature.
5. Provide C/Python and source code with Socket-CAN for Raspbian(Linux), Dynamic library and demo with IOUSBKit for Mac Os(Big Sur).

### 3. Technical Specification

#### 3.1 USB2CAN module and USB2CAN-Dev

<b>Product Part Number:</b> <b>USB2CAN Module</b>	<b>Features</b>	USB2CAN PCBA, High performance cost and easy for install in your product shell
	<b>CAN Port</b>	D-SUB, 9 pins
	<b>USB Port</b>	USB 2.0 Full-Speed
	<b>Specification</b>	2.0A (standard format) and 2.0B (extended format), ISO 11898-2 High-speed CAN
	<b>CAN-BUS Baud rate</b>	From 20kbps to 1Mbps can be programmed arbitrarily.
	<b>Isolation Voltage</b>	1.5K VDC/min, 3K VDC/1s
	<b>Microcontroller</b>	STM32F0
	<b>Termination</b>	120 Ohm resistor selectable jumper
	<b>CAN Transceiver</b>	ISO1050DUBR ,Texas Instruments
	<b>Work Temperature</b>	-40° ~ 85
	<b>Relative humidity</b>	15-90%, not condensing
	<b>Weight</b>	15.5 g
	<b>Certificate</b>	CE / FCC SDOC

### 3.2 USB2CAN-DEV

<b>Product Part Number:</b> <b>USB2CAN-DEV</b>	<b>Features</b>	USB2CAN stamp-core module development board. You could use the core module in your circuit design to add USB to CAN function.
	<b>CAN Port</b>	D-SUB, 9 pins
	<b>USB Port</b>	USB 2.0 Full-Speed
	<b>Specification</b>	2.0A (standard format) and 2.0B (extended format), ISO 11898-2 High-speed CAN
	<b>CAN-BUS Baud rate</b>	From 20kbps to 1Mbps can be programmed arbitrarily.
	<b>Isolation Voltage</b>	1.5K VDC/min, 3K VDC/1s
	<b>Microcontroller</b>	STM32F0
	<b>Termination</b>	120 Ohm resistor selectable jumper
	<b>CAN Transceiver</b>	ISO1050DUBR ,Texas Instruments
	<b>Work Temperature</b>	-40° ~ 85
	<b>Relative humidity</b>	15-90%, not condensing
	<b>Weight</b>	15.5 g
	<b>Certificate</b>	USB2CAN-Core stamp-core module get CE / FCC SDOC/ UKAC/ICES

### 3.3 USB2CAN-C

<b>Product Part Number:</b> <b>USB2CAN-C</b>	<b>Features:</b>	USB2CAN module with shell and USB cable. Safer and more flexible.
	<b>CAN Port</b>	D-SUB, 9 pins
	<b>USB Port</b>	USB 2.0 Full-Speed
	<b>Specification</b>	2.0A (standard format) and 2.0B (extended format), ISO 11898-2 High-speed CAN
	<b>CAN-BUS Baud rate</b>	From 20kbps to 1Mbps can be programmed arbitrarily.
	<b>Isolation Voltage</b>	1.5K VDC/min, 3K VDC/1s
	<b>Microcontroller</b>	STM32F0
	<b>Termination</b>	120 Ohm resistor by external added only
	<b>CAN Transceiver</b>	ISO1050DUBR ,Texas Instruments
	<b>Work Temperature</b>	-40° ~ 85
	<b>Relative humidity</b>	15-90%, not condensing
	<b>Weight</b>	50 g
	<b>Certificate</b>	CE / FCC SDOC/ UKAC/ICES



### 3.4 USB2CAN-X2

<b>Product Part Number:</b> <b>USB2CAN-X2</b>	<b>Features</b>	Dual channels CAN via one USB ports only, Can be set up and communication independently. Higher voltage isolation and more sturdy metal casing.
	<b>CAN Port</b>	D-SUB, 9 pins x 2
	<b>USB Port</b>	USB 2.0 Full-Speed
	<b>Specification</b>	2.0A (standard format) and 2.0B (extended format), ISO 11898-2 High-speed CAN Dual channels can be set up independently
	<b>CAN-BUS Baud rate</b>	From 20kbps to 1Mbps can be programmed arbitrarily.
	<b>Isolation Voltage</b>	Bus-Pin ESD protection up to 15kV(HBM) High isolation up to 5000 VDC/1s
	<b>Microcontroller</b>	STM32F0
	<b>Termination</b>	120 Ohm resistor build-in setting and external added
	<b>CAN Transceiver</b>	TD541SCANH ,MORNSUN
	<b>Work Temperature</b>	-40° ~ 85
	<b>Relative humidity</b>	15-90%, not condensing
	<b>Weight</b>	150 g
	<b>Certificate</b>	CE / FCC SDOC/ UKAC/ICES

### 3.5 MINIPCIE-CAN

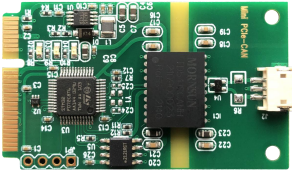
<b>Product Part Number: MINIPCIE-CAN</b>	<b>Features</b>	Standard MINI PCIE port to CAN bus. Fully suitable for the MINI PCIE port of PC and ARM chip.
	<b>CAN Port</b>	3 pins 1.5mm separation distance
	<b>PCIE Port</b>	Full-Mini PCIE , 52Pins
	<b>Specification</b>	2.0A (standard format) and 2.0B (extended format), ISO 11898-2 High-speed CAN
	<b>CAN-BUS Baud rate</b>	From 20kbps to 1Mbps can be programmed arbitrarily.
	<b>Isolation Voltage</b>	Bus-Pin ESD protection up to 15kV(HBM) High isolation up to 5000 VDC/1s
	<b>Microcontroller</b>	STM32F0
	<b>Termination</b>	120 Ohm resistor build-in setting and external added
	<b>CAN Transceiver</b>	TD541SCANH ,MORNSUN
	<b>Work Temperature</b>	-40° ~ 85
	<b>Relative humidity</b>	15-90%, not condensing
	<b>Weight</b>	15 g

## 4. Hardware Description

### 4.1 USB2CAN module and USB2CAN-Dev

#### (1) CAN Connector Pinout

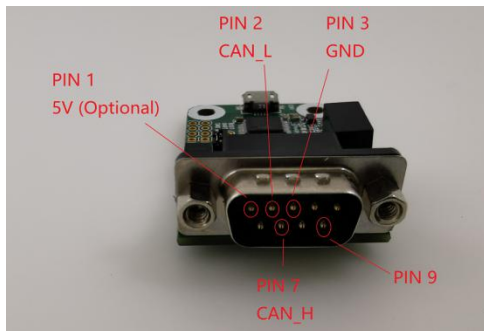
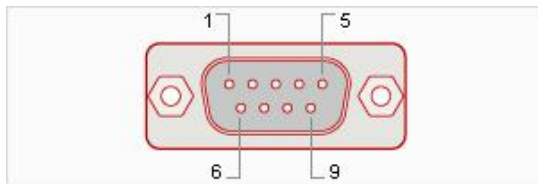

Pin	Description
1	5V/150ma output . Weld 0Ω resistor on R9 to enable this function(close to the jumper).
2	CANL bus line (dominant low)
3	CAN_GND
4	NC
5	NC
7	CANH bus line (dominant high)
8	NC
9	NC

#### (2) 120 Ohm Resistor Setting.

A High-speed CAN bus (ISO 11898-2) must be terminated on both ends with 120 Ohms. There are three ways to enable the 120Ω resistance.



Disable 120 Ohm Resistor

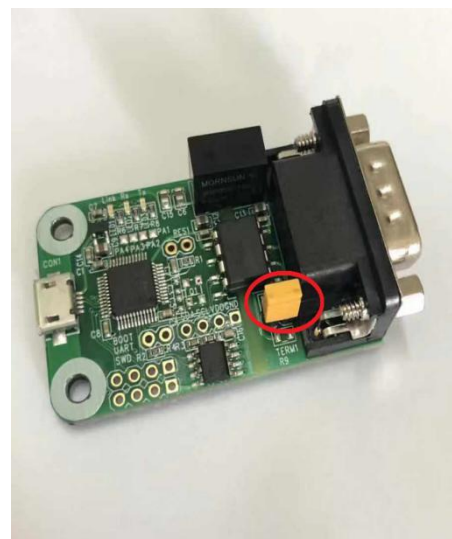

Enable 120 Ohm Resistor

**(3) LED Indicate**

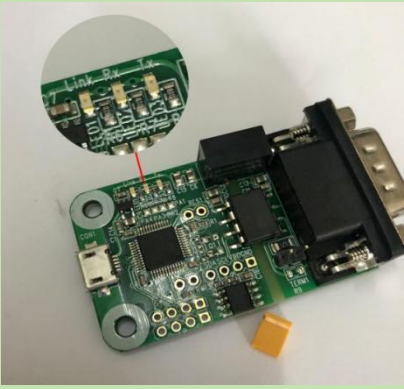
	LED Name	Description
	Link	Red led is normally on to indicate The module is came up without any errors
	Tx	Red led flash to indicate send data.
	Rx	Red led flash to indicate receive data.

**(4) Dimension Figure**

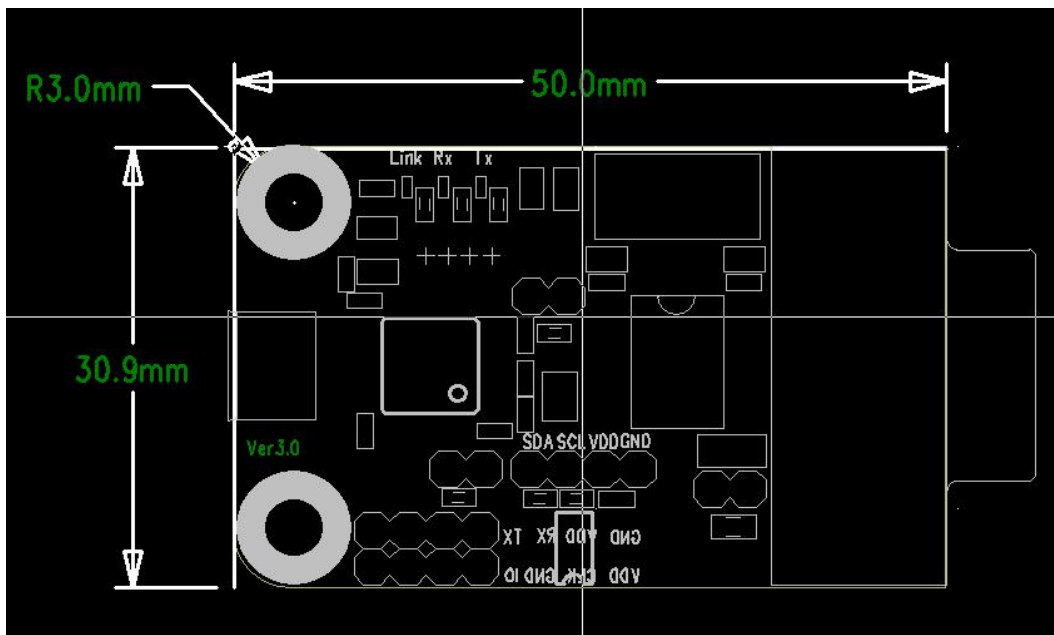

## 4.2 USB2CAN-C

### (1) CAN Connector Pinout

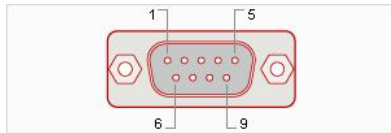

Pin	Description
1	NC
2	CAN_L bus line (dominant low)
3	CAN_GND
4	NC
5	NC
7	CAN_H bus line (dominant high)
8	NC
9	NC

### (2) 120 Ohm Resistor Setting.

A High-speed CAN bus (ISO 11898-2) must be terminated on both ends with 120 Ohms. There are three ways to enable the 120  $\Omega$  resistance.

There is a DB9 to 3pins terminal comes with goods. they have the 120  $\Omega$  resistance selectable feature.



**(3) LED Indicate**

Product	LED Name	Description
	Link	Green led is normally on to indicate the module is came up with out any errors
	Tx	Green led is normally on to indicate the usb2can is Green led flash to indicate send data.
	Rx	Green led flash to indicate receive data.

**(4) Dimension Figure**

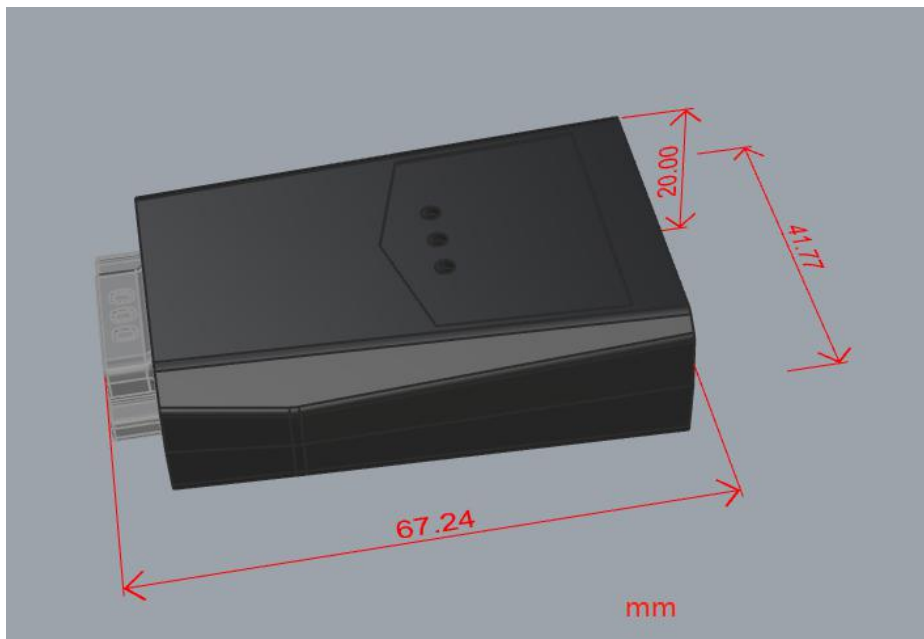

## 4.3 USB2CAN-X2

### (1) CAN Connector Pinout

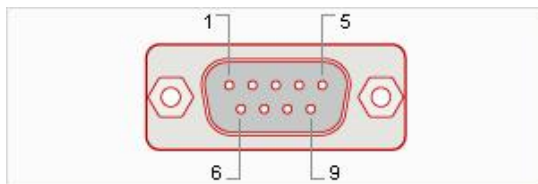
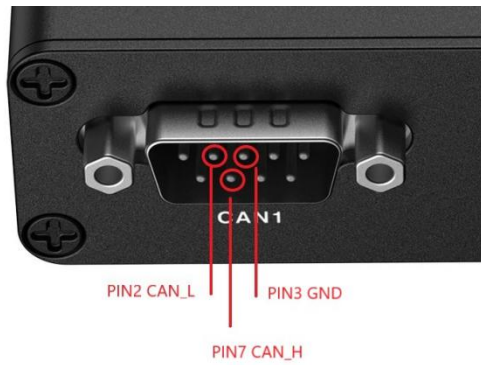

Pin	Description
1	NC
2	CANL bus line (dominant low)
3	CAN_GND
4	NC
5	NC
6	NC
7	CANH bus line (dominant high)
8	NC
9	NC

### (2) 120 Ohm Resistor Setting.

A High-speed CAN bus (ISO 11898-2) must be terminated on both ends with 120 Ohms. There are three ways to enable the 120  $\Omega$  resistance.

There are two DB9 to 3pins terminal comes with goods. they have the 120  $\Omega$  resistance selectable feature.

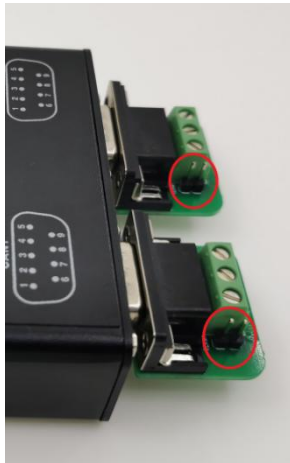

Disable the 120  $\Omega$  resistance

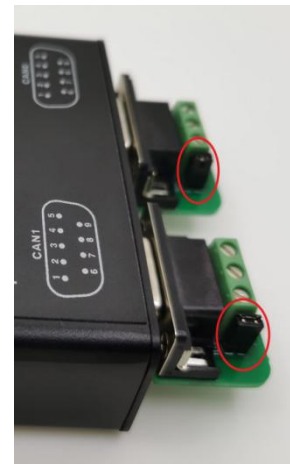

Enable the 120  $\Omega$  resistance

If you want to enable the 120  $\Omega$  resistance all the time. You can open the shell and enable the build-in resistance.

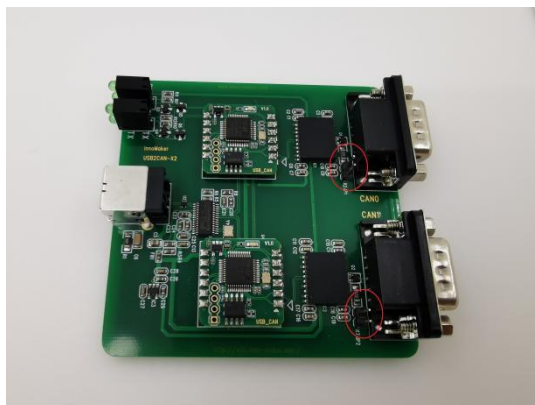

Disable the 120  $\Omega$  resistance

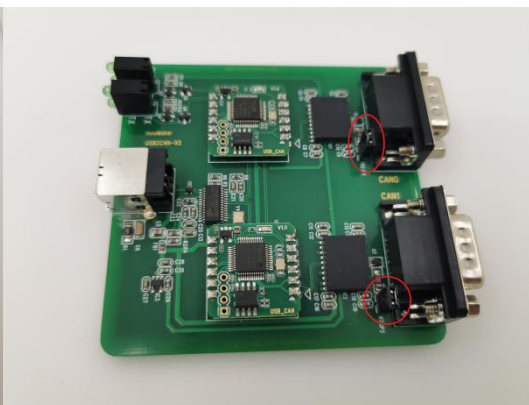

Enable the 120  $\Omega$  resistance



**(3) LED Indicate**

Operation	Appearance
	<p>When you plug the device into the USB port of the computer, All lights are flashing for one second and then all LED goes off.</p>
	<p>Enable CAN0 only , The TX/RX LED of CAN0 should be on.</p>
	<p>Enable CAN1 only , The TX/RX LED of CAN0 should be on.</p>
	<p>Enable CAN0 and CAN1 both, All LED should be on.</p>

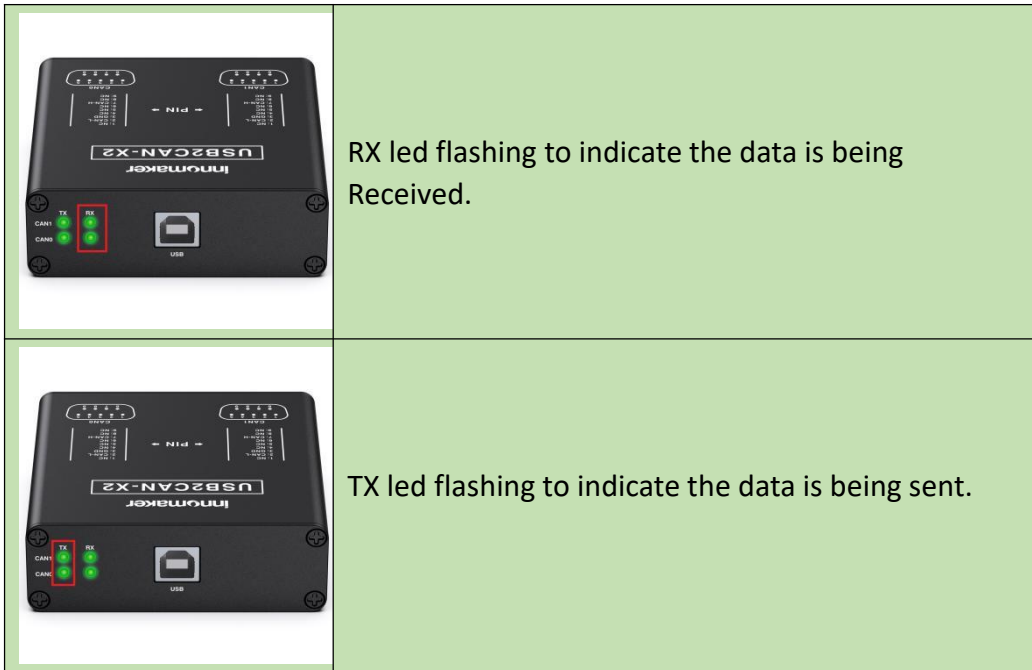

**(4) Dimension Figure**

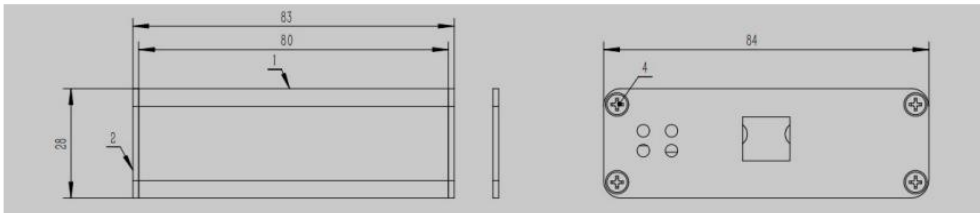

## 4.4 MINIPCIE-CAN

### (1) CAN Connector Pinout

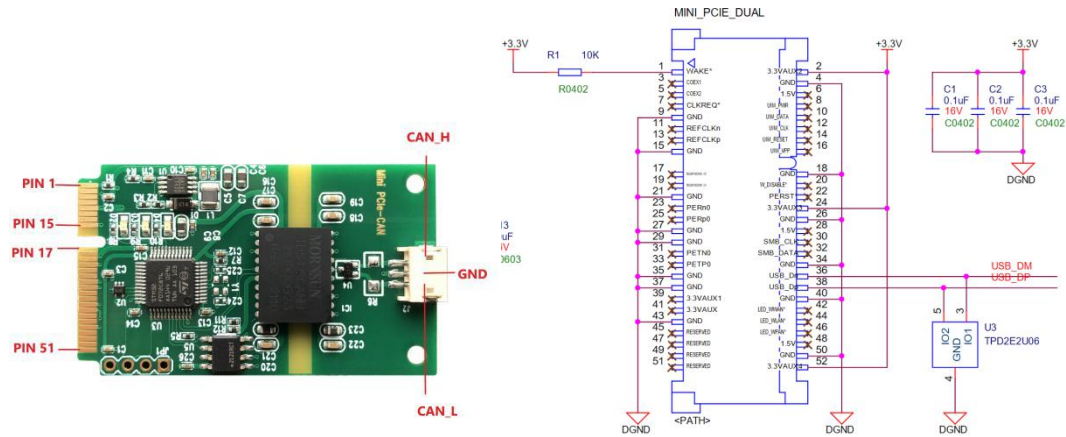

### (2) 120 Ohm Resistor Setting.

A High-speed CAN bus (ISO 11898-2) must be terminated on both ends with 120 Ohms. There are three ways to enable the 120 Ω resistance.

There is a on-board reserved 120 Ohm Resistor with 1206 package.

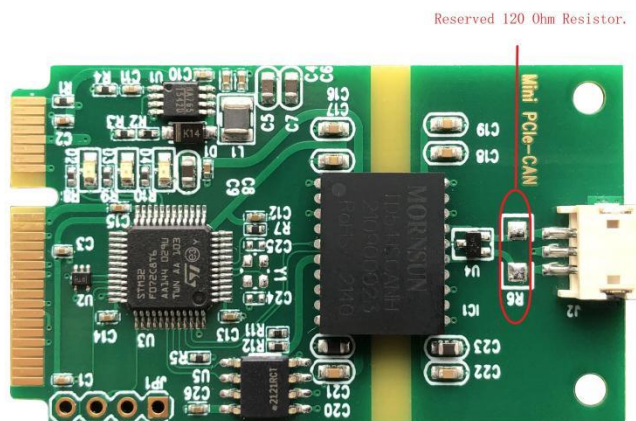

There is a DB9 to 3pins terminal comes with goods. they have the 120 Ω resistance selectable feature.



**(3) LED Indicate**

	LED Name	Description
	Link	Red led is normally on to indicate The module is came up without any errors
	Tx	Red led flash to indicate send data.
	Rx	Red led flash to indicate receive data.

(4) Dimension Figure

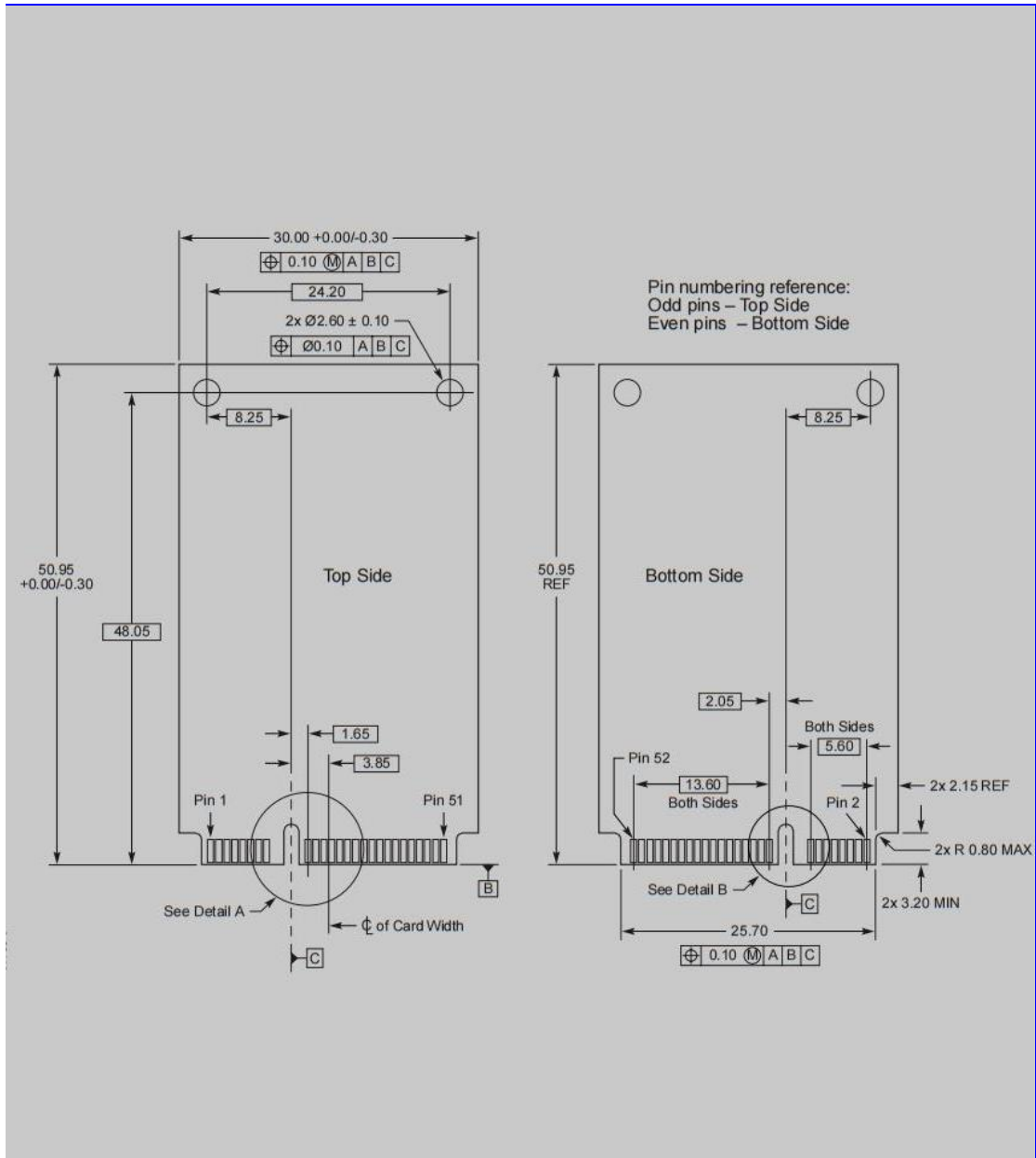

## 5. Windows/Mac OS Ready-Made Tools

Download the tools installation package from below link:

<https://github.com/INNO-MAKER/usb2can>

### 5.1 Open the USB2CAN tools.

Download and install the ready-made tool. One tool interface is only for one device. If you want to use two devices at the same time, Please open two interfaces.

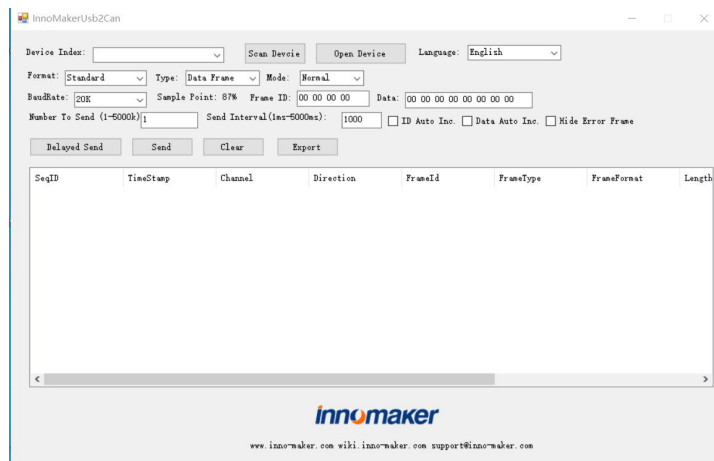

### 5.2 Scan For Devices

Plug the device into the USB port of your computer, click 'Scan Device' button. You'll Find USB2CAN device and named with different ID.

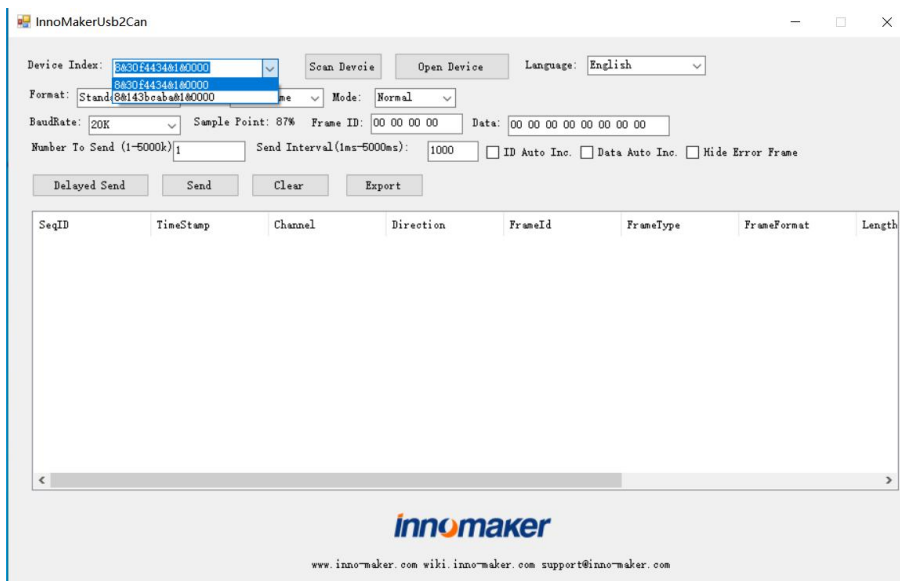

### 5.3 Setting The BandRate And Working Mode.

Setting below parameters in the red box before open device.

**Normal mode:** The CAN module will appear on the CAN-bus, and it can send and receive CAN messages, communication with other CAN devices directly.

**Silent mode:** The module will appear on the CAN-bus, but in a passive state. It can receive CAN messages, but cannot transmit CAN messages or answer. This mode can be used as a bus monitor because it does not affect CAN-bus communications but can observe the CAN-bus states.

**Loopback mode:** For USB2CAN self-test, CAN module receives its own messages. In this mode, the send part of the CAN module is connected internally with the reception one.

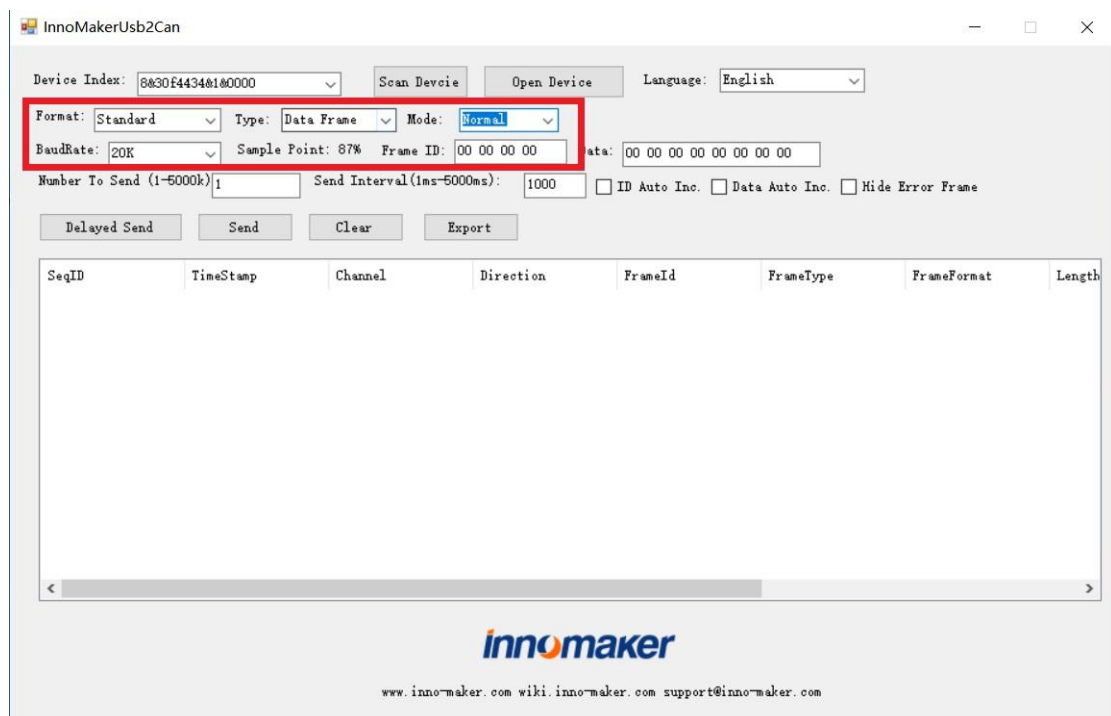

## 5.4 Enable Device.

Click 'Open device', the TX/RX LED light up.

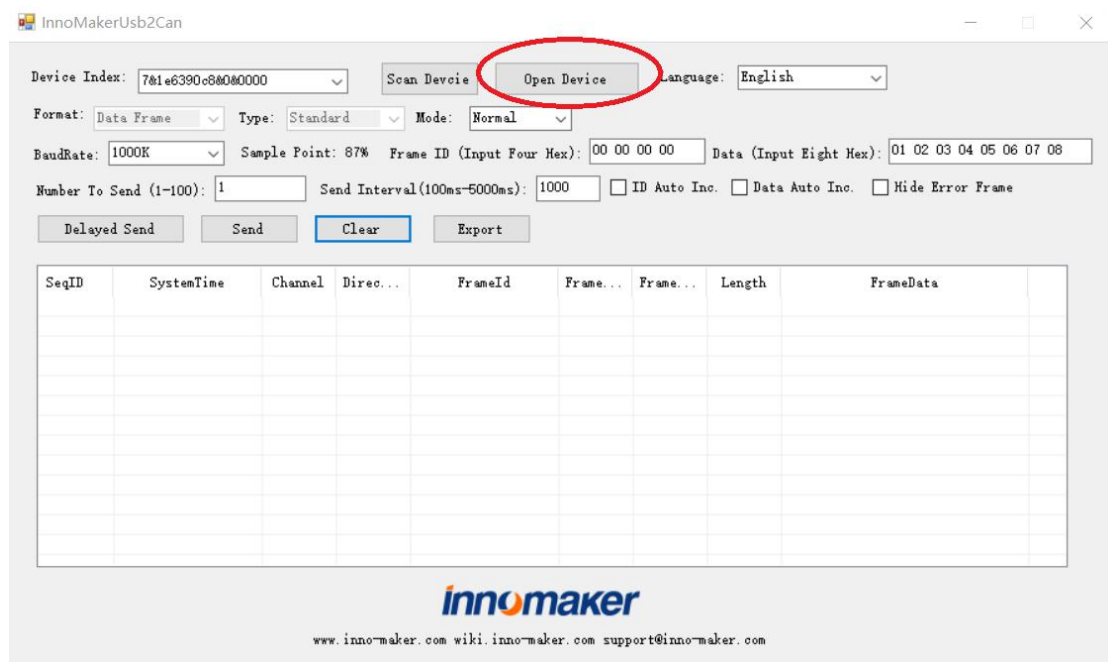

## 5.5 Send/Receive Data

After Open device, the device will automatic received data. The send data will be marked in black, Receive data will be marked in green. Error Frame will be marked in red. Every message will comes with the time stamp and serial number.

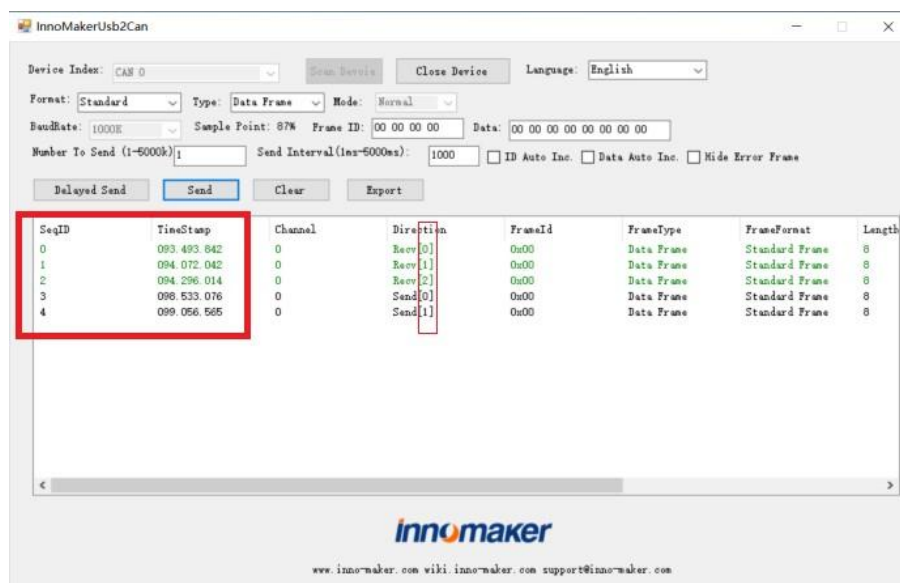



## 5.6 Windows Real Time Setting

If you want to test the USB2CAN module on at high speed and mass data mode (such as send/receive one million frames with 1 millisecond interval), please change the base priority level, That would be very helpful.

I take Windows 10 for example.

Open Task Manger

→ right click on innomaker application process

→ left click on 'go to details'

→ right click on innomaker application process

→ left click on 'set priority'

→ left click on 'realtime'

## 5.7 Mac Os Double Open The USB2CAN Tool

Open the terminal of MacOS, if you can't find it, please googling it. Type 'open -n' + the software path. If you don't know the path, drag and drop the application icon.

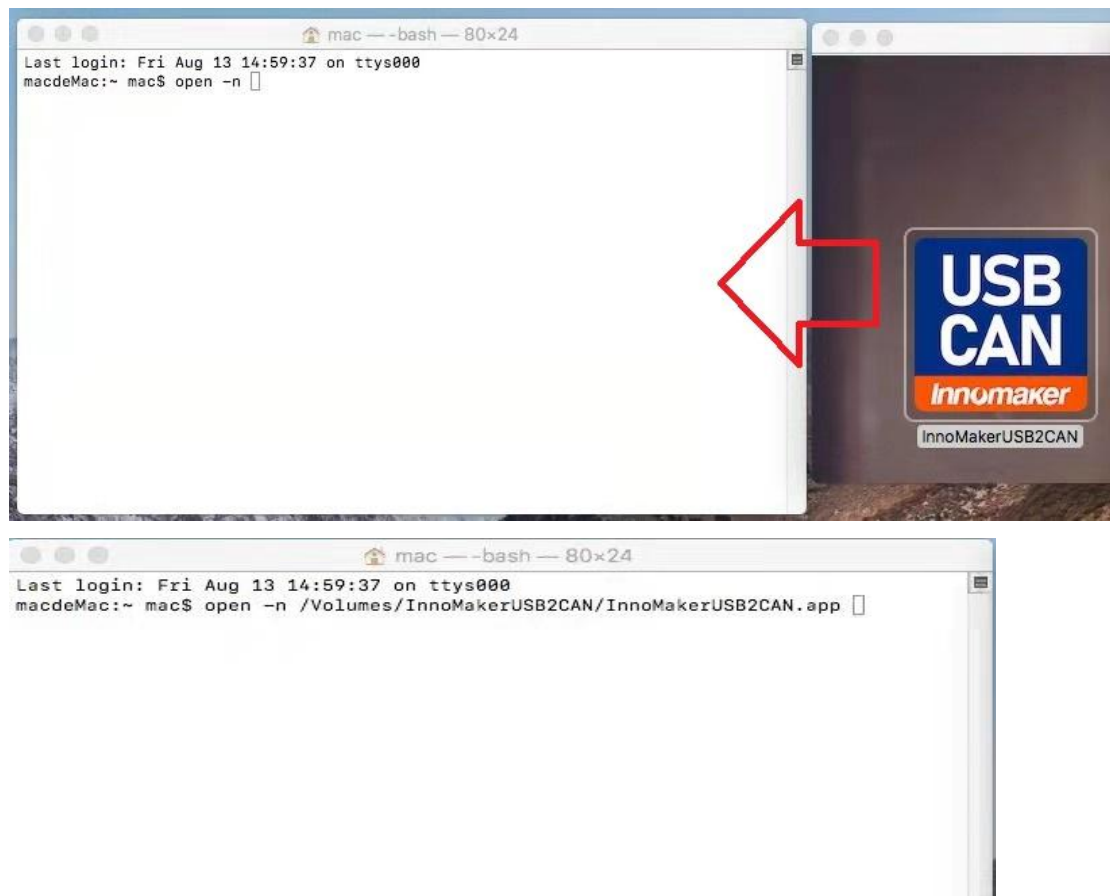

## 6. Windows API

If you are not familiar with the CAN communication and WINDOWS software development, it is strongly recommended you that use the ready-made application we provide or entrust us with the development.

Released Date: 2021-07-16

Version No: 1.2.0

### 6.1 Dynamic Link Libraries

Name	Size	Modified Time
InnoMakerUsb2CanLib.dll	12 KB	2020-06-27
LibUsbDotNet.LibUsbDotNet.dll	153 KB	2018-09-25

InnoMakerUsb2CanLib.dll: USB2CAN function dynamic link libraries.

LibUsbDotNetLibUsbDotNet.dll : WINDOWS USB Universal Interface dynamic link libraries.

### 6.2 Structure

```
public struct innomaker_host_frame
{
    public UInt32 echo_id; //The echo-id identifies the frame from (echos the id from a
                          //previous UCAN_OUT_TX message).

    public UInt32 can_id;    //CAN ID   Reserved for dual CAN Device
    public Byte can_dlc;    // data len   0~8
    public Byte channel;    // channel number, Reserved,useless
    public Byte flags;      //additional flags,Reserved,useless
    public Byte reserved;   //reserved / padding
    [MarshalAs(UnmanagedType.ByValArray, SizeConst = 8)]
    public Byte[] data;     //CAN data
    public UInt32 timestamp_us; //times stamp
}
```

```
public struct innomaker_device_bittming
{
    public UInt32 prop_seg;           //propagation Segment
    public UInt32 phase_seg1;        //phase segment 1 (1~15)
    public UInt32 phase_seg2;        //phase segment 2 (1~8)
    public UInt32 sjw;                //synchronization segment (1~4)
    public UInt32 brp;                //clock divider, USB2CAN moduel clock is 48M
}

public enum UsbCanMode
{
    UsbCanModeNormal,               //Normal working mode
    UsbCanModeLoopback,             // Loopback mode
    UsbCanModeListenOnly,           // Listen only, not ACK
}
```

## 6.3 CallBack

### (1) public delegate void AddDeviceNotifyDelegate() ;

-Summary: If Device Plug In, it will call the delegate

### (2) RemoveDeviceNotifyDelegate();

**public delegate void RemoveDeviceNotifyDelegate();**

-Summary: If Device Plug Out, it will call the delegate

## 6.4 Function

### (1) GetDllVersion

**public String GetDllVersion()**

-Summary: Return Current Dll Version

-Return: Current Dll Version

### (2) scanInnoMakerDevices

**public bool scanInnoMakerDevices()**

-Summary: Scann Inno Maker Devices

-Return: Scan success return true , else return false

### (3) getInnoMakerDeviceCount

**public int getInnoMakerDeviceCount()**

-Summary: Get Device Count

-Return: Device count

### (4) getInnoMakerDevice

**public InnoMakerDevice getInnoMakerDevice(int devIndex)**

-Summary: Get Inno Maker device by device index

-devIndex: Device index

-return: Inno Maker Device Instance

### (5) openInnoMakerDevice

**public bool openInnoMakerDevice(InnoMakerDevice device)**

-Summary: Open Device

-param: device

-return: if open success return true,else return false

## (6) closeInnoMakerDevice

**public bool closeInnoMakerDevice(InnoMakerDevice device)**

-Summary: Close Device

-param: device

-return: if Close success return true, else return false

## (7) asyncGetInnoMakerDeviceBuf

**public bool asyncGetInnoMakerDeviceBuf(InnoMakerDevice device,  
Byte[] buf,  
int size,  
int transferredIn,  
int timeout)**

-Summary: Read buffer from device async

-param: device

-param: buf, buffer reads in

-param: size, buffer size

-param: transferredIn, actually buffer length reads

-param: timeout, read buffer timeout, This is specified in milliseconds

-return: if read device success, return true, else return false

## (8) syncGetInnoMakerDeviceBuf

**public bool syncGetInnoMakerDeviceBuf(InnoMakerDevice device,  
Byte[] buf,  
int size,  
int transferredIn,  
int timeout)**

-Summary: Read buffer from device sync

-param: device

-param: buf, buffer reads in

-param: size, buffer size

-param: transferredIn, actually buffer length reads

-param: timeout, read buffer timeout, This is specified in milliseconds.

-return: if read device success, return true, else return false

### (9) asyncGetInnoMakerDeviceBuf

```
public bool asyncGetInnoMakerDeviceBuf(InnoMakerDevice device,  
                                        Byte[] buf,  
                                        int size,  
                                        int timeout,int transferredOut)
```

- Summary: write buffer to device async
- param: device
- param: buf, buffer writes out
- param: size, buffer size
- param: transferredOut, actually buffer length writes
- param: timeout, write buffer timeout, This is specified in milliseconds.
- return: if write device success, return true, else return false

### (10) syncGetInnoMakerDeviceBuf

```
public bool syncGetInnoMakerDeviceBuf(InnoMakerDevice device,  
                                       Byte[] buf,  
                                       int size,  
                                       int timeout,  
                                       int transferredOut)
```

- Summary: write buffer to device sync
- param: device
- param: buf, buffer writes out
- param: size, buffer size
- param: transferredOut, actually buffer length writes
- param: timeout, write buffer timeout
- return: if write success, return true, else return false

### (11) UrbResetDevice

```
public bool UrbResetDevice(InnoMakerDevice device)
```

- Summary: Reset Device
- param: Device Instance
- return: If reset device success return true, else return false

## (12) UrbSetupDevice

```
public bool UrbSetupDevice(InnoMakerDevice device,  
                           UsbCanMode canMode,  
                           innomaker_device_bittming bittming)
```

-Summary: Setup device

-param: Device Instance

-param: canMode, usbCanMode

-param: bittming, usb bittming params

-return: if setup device success return true, else return false

## 7. Mac Os API

Download the tools and SDK of Mac Os from below link:

<https://www.jianguoyun.com/p/DVvY6VIQpdSrBxjyqKUB>

<https://github.com/INNO-MAKER/usb2can>

There are consists of four parts:





- 📁 doc\_html
- 📁 InnoMaker USB2CAN Tools
- 📁 Lib
- 📁 Tools Source Code

Folder name	Description
<b>InnoMaker USB2CAN Tools</b>	InnoMaker USB2CAN test tools, You can run natively on Mac OS version equal or above 10.11. If Mac os
<b>Tools Source Code</b>	The source of InnoMaker USB2CAN test tools, to show you how to use the SDK to develop a usb to can application.
<b>Lib</b>	The Library function for develop USB2CAN applications. These libraries are not open source. If you have any problem and suggestion, feel free to contract us.
<b>doc_html</b>	Simple document for library description.



## 7.1 Library







Open the Lib folder, There are three files in it:

 .DS_Store	2020/5/10 14:58
 libInnoMakerUSBIOLib.dylib	2020/5/10 14:57
 UsbIO.h	2020/5/10 14:55
 USBIO+USBCAN.h	2020/5/10 14:50

Filename	Description
UsbIO.h	USB Common Interface
USBIO+USBCAN.h	USB Special For CAN Interface
libInnoMakerUSBIOLib.dylib	Dynamic library file

## 7.2 Document

Open the doc\_html folder and open the index.html files. You can see InnoMakerUSB IO LIB reference.

 Classes	2020/5/11 13:10	文件夹	
 css	2020/5/11 12:53	文件夹	
 img	2020/5/11 12:53	文件夹	
 js	2020/5/11 12:53	文件夹	
 Protocols	2020/5/11 13:10	文件夹	
 hierarchy.html	2020/5/11 13:10	360 se HTML Do...	2 KB
 index.html	2020/5/11 13:10	360 se HTML Do...	2 KB

InnoMakerUSBIOLib innomaker

[Hierarchy](#)

## InnoMakerUSBIOLib Reference

### Class References

- [InnoMakerDevice](#)
- [UsbIO](#)

### Protocol References

- [InnoMakerDeviceDelegate](#)

Copyright © 2020 innomaker. All rights reserved. Updated: 2020-05-11  
Generated by [appledoc 2.2.1 \(build 1334\)](#).

## 8. Linux/Ubuntu/Raspbian

### 8.1 Run Test Demo

USB2CAN device can run properly without any additional driver request on all Linux system since version 3.9. such as Ubuntu, Debian and Raspbian. If you meet driver problem on the old version You need to reconfigure the kernel drivers. Enable 'gs\_usb.c' and install 'gs\_usb.ko' into system. So notice that if you only compile this drivers, It may fail to load in system. At this time, compile fully with new configures. If you have any question, feel free to e-mail to our support team(support@inno-maker.com).

You could test the USB2CAN device with all single board computer, PC or laptop with the right Linux version. We take Raspberry Pi 4 as an example to show you how to run the C/Python and can-utils demo.

For demonstration purposes, I take two USB2CAN device to show the communication.

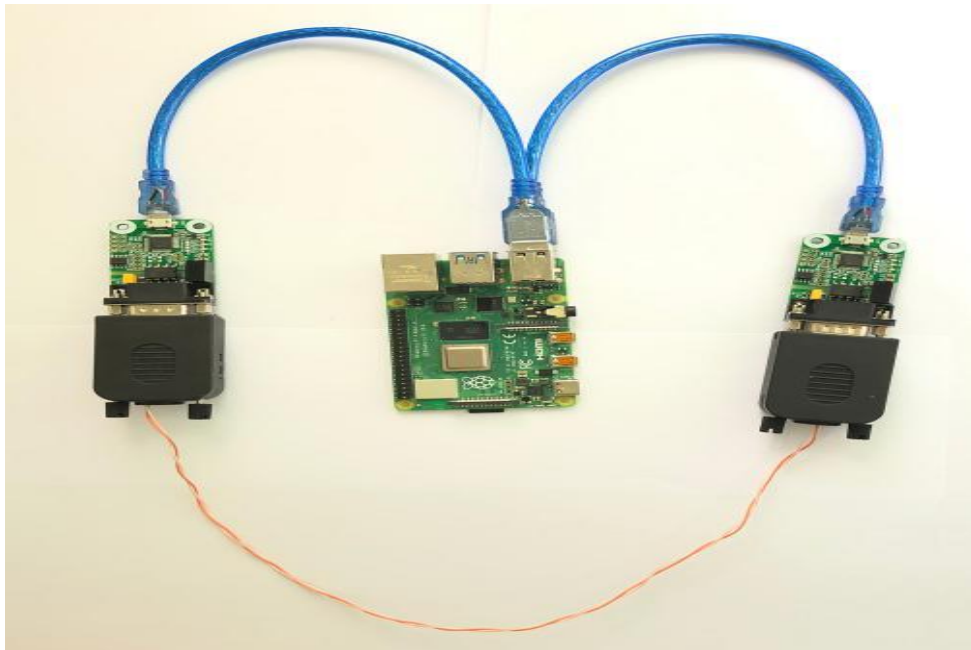

Please download the codes and tools from below links:

<https://github.com/INNO-MAKER/usb2can>

## 8.1.1 Preparatory work

### 8.1.1.1 Connection

Plug the USB2CAN device into the USB Host of Raspberry Pi. And then connect the CAN\_H pin and CAN\_L pin to each other. No GND pin connection requirement.

CAN 0 Channel	Connection	CAN 1 Channel
CAN_L(pin 2)	-----	CAN_L(pin 2)
CAN_H(pin 7)	-----	CAN_H(pin 7)

### 8.1.1.2 ifconfig -a

Type command 'ifconfig -a' to check 'can0' and 'can1' device is available in system.

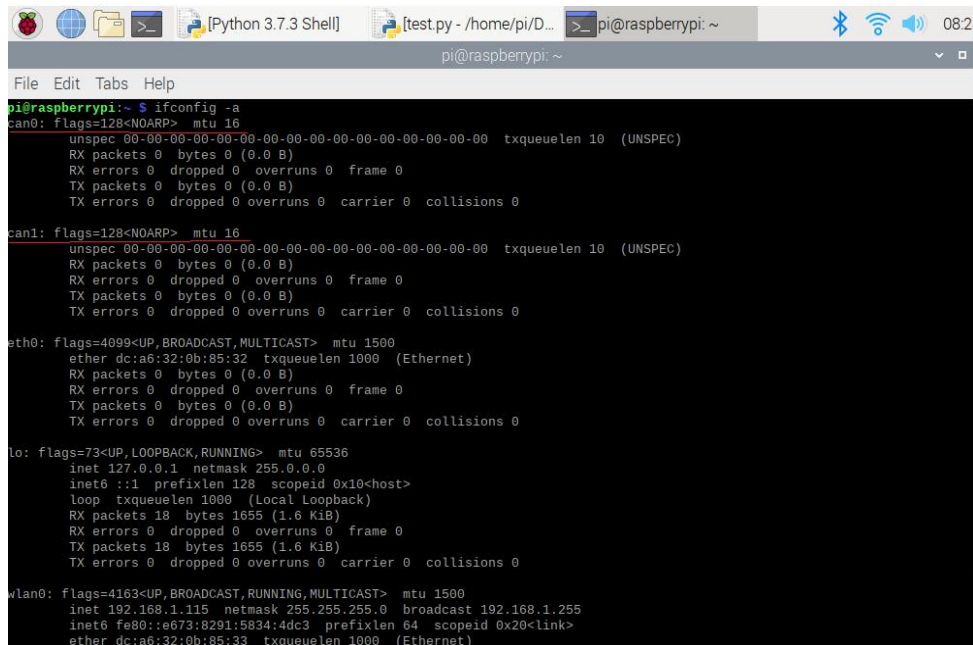

```

pi@raspberrypi:~$ ifconfig -a
can0: flags=128<NOARP> mtu 16
    unspec 00-00-00-00-00-00-00-00-00-00-00-00-00-00-00-00 txqueuelen 10 (UNSPEC)
    RX packets 0 bytes 0 (0.0 B)
    RX errors 0 dropped 0 overruns 0 frame 0
    TX packets 0 bytes 0 (0.0 B)
    TX errors 0 dropped 0 overruns 0 carrier 0 collisions 0

can1: flags=128<NOARP> mtu 16
    unspec 00-00-00-00-00-00-00-00-00-00-00-00-00-00-00-00 txqueuelen 10 (UNSPEC)
    RX packets 0 bytes 0 (0.0 B)
    RX errors 0 dropped 0 overruns 0 frame 0
    TX packets 0 bytes 0 (0.0 B)
    TX errors 0 dropped 0 overruns 0 carrier 0 collisions 0

eth0: flags=4099<UP,BROADCAST,MULTICAST> mtu 1500
    ether dc:a6:32:0b:85:32 txqueuelen 1000 (Ethernet)
    RX packets 0 bytes 0 (0.0 B)
    RX errors 0 dropped 0 overruns 0 frame 0
    TX packets 0 bytes 0 (0.0 B)
    TX errors 0 dropped 0 overruns 0 carrier 0 collisions 0

lo: flags=73<UP,LOOPBACK,RUNNING> mtu 65536
    inet 127.0.0.1 netmask 255.0.0.0
    inet6 ::1 prefixlen 128 scopeid 0x1<host>
    loop txqueuelen 1000 (Local Loopback)
    RX packets 18 bytes 1655 (1.6 KiB)
    RX errors 0 dropped 0 overruns 0 frame 0
    TX packets 18 bytes 1655 (1.6 KiB)
    TX errors 0 dropped 0 overruns 0 carrier 0 collisions 0

wlan0: flags=4163<UP,BROADCAST,RUNNING,MULTICAST> mtu 1500
    inet 192.168.1.115 netmask 255.255.255.0 broadcast 192.168.1.255
    inet6 fa80::e673:8291:5834:4dc3 prefixlen 64 scopeid 0x20<link>
    ether dc:a6:32:0b:85:33 txqueuelen 1000 (Ethernet)
  
```

### 8.1.1.3 dmesg

You can type command 'dmesg' for see more information about USB2CAN module at the bottom.

```
3.100730] usb 1-1.1.1: New USB device found, idVendor=1d50, idProduct=606f, bcdDevice= 0.00
3.100755] usb 1-1.1.1: New USB device strings: Mfr=1, Product=2, SerialNumber=3
3.100773] usb 1-1.1.1: Product: USB2CAN v1
3.100790] usb 1-1.1.1: Manufacturer: InnoMaker
3.100807] usb 1-1.1.1: SerialNumber: 002C00325353530620313737
3.184277] i2c /dev entries driver
3.303669] usb 1-1.1.2: new full-speed USB device number 6 using xhci_hcd
3.542779] usb 1-1.1.2: New USB device found, idVendor=1d50, idProduct=606f, bcdDevice= 0.00
3.542803] usb 1-1.1.2: New USB device strings: Mfr=1, Product=2, SerialNumber=3
3.542822] usb 1-1.1.2: Product: USB2CAN v1
3.542839] usb 1-1.1.2: Manufacturer: InnoMaker
3.542856] usb 1-1.1.2: SerialNumber: 002B00315353530620313737
```

### 8.1.2 Run can-utils Tool

This tool is a very easy way to test USB2CAN module communication. There is only a simple use instruction. For more details, please refer to can-utils usermanual and source code.

<https://github.com/linux-can/can-utils/>

#### 8.1.2.1 -Install Tools

```
sudo apt-get install can-utils
```

#### 8.1.2.2 -Send And Receive Test

(1) Initialize CAN port, After below command, you could see the the TX/RX light on for CAN0 and CAN1 channels.

```
sudo ip link set can0 down
sudo ip link set can0 type can bitrate 125000
sudo ip link set can0 up
```

```
sudo ip link set can1 down
sudo ip link set can1 type can bitrate 125000
sudo ip link set can1 up
```

(2) Set CAN0 as receiver

```
candump can0
```

(3) Set CAN1 as sender

```
cansend can1 123#1234567890
```

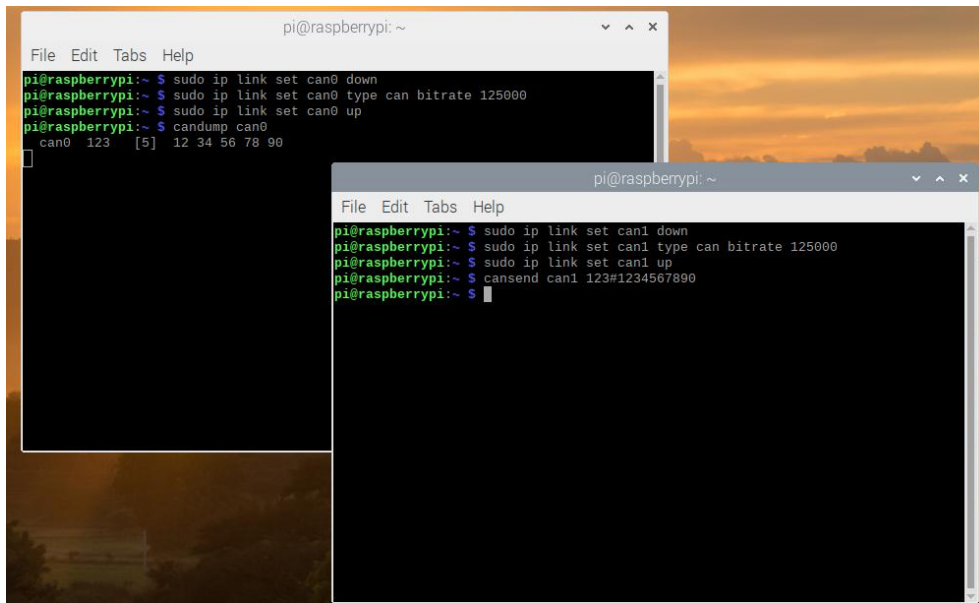

### 8.1.2.3 -Loopback Mode Test

```
sudo ip link set can0 down
```

```
sudo ip link set can0 type can bitrate 125000 loopback on
```

```
sudo ip link set can0 up
```

```
candump can0 & cansend can0
```

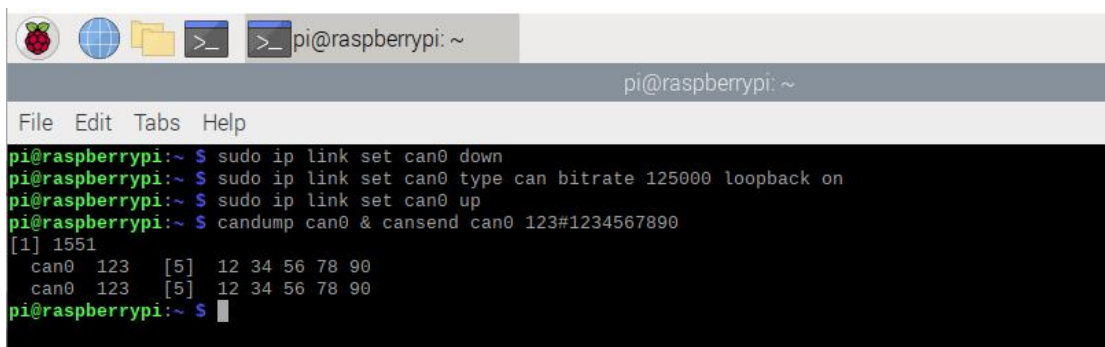

### 8.1.3 Run C Demo

(1) Load C Demo named 'usb2cantest' from our Wiki and up-zip it to the desktop of Raspbian.

[http://www.inno-maker.com/wiki/doku.php?id=usb\\_can](http://www.inno-maker.com/wiki/doku.php?id=usb_can)

Or <http://www.inno-maker.com/wiki/doku.php>

(2) Go to folder named 'c' and change the permissions.

```
chmod -R a+rwX *
```

```
pi@raspberrypi: ~/Desktop/c
pi@raspberrypi:~/Desktop/c $ cd Desktop/c
pi@raspberrypi:~/Desktop/c $ chmod -R a+rwX *
pi@raspberrypi:~/Desktop/c $
```

(3) Set one as receiver, execute following commands in serial terminal. Now this Raspberry pi is blocked.

```
./can0_receive
```

(4) Set the other Pi as sender, execute following commands.

```
./can1_send
```

```
pi@raspberrypi:~/Desktop/usb2cantest
pi@raspberrypi:~/Desktop $ cd Desktop
pi@raspberrypi:~/Desktop/usb2cantest $ cd usb2cantest
pi@raspberrypi:~/Desktop/usb2cantest $ chmod -R a+rwX *
pi@raspberrypi:~/Desktop/usb2cantest $ ls
can0_receive  can1_receive  can1_test     can_send     cantool      can-utils-master  rs485_test  setup
can0_send     can1_send     can_receive   can_server   cantool-sh   can-utils-master.zip  rs485_test-sh
pi@raspberrypi:~/Desktop/usb2cantest $ ./can0_receive
This is a can receive demo,can0 with 1Mbps!
Received standard frame!
can_id = 0x123
can_dlc = 8
data[0] = 1
data[1] = 2
data[2] = 3
data[3] = 4
data[4] = 5
data[5] = 6
data[6] = 7
data[7] = 8
pi@raspberrypi:~/Desktop/usb2cantest $

pi@raspberrypi:~/Desktop/usb2cantest
pi@raspberrypi:~/Desktop $ cd Desktop
pi@raspberrypi:~/Desktop/usb2cantest $ cd usb2cantest
pi@raspberrypi:~/Desktop/usb2cantest $ ls
can0_receive  can1_send     can_send     cantool-sh   rs485_test
can0_send     can1_test     can_server   can-utils-master  rs485_test-sh
can1_receive  can_receive   cantool      can-utils-master.zip  setup
pi@raspberrypi:~/Desktop/usb2cantest $ ./can1_send
This is a socket can transmit demo program ,can1 with 1Mbps baud rate
Transmit standard frame!
can_id = 0x123
can_dlc = 8
data[0] = 1
data[1] = 2
data[2] = 3
data[3] = 4
data[4] = 5
data[5] = 6
data[6] = 7
data[7] = 8
pi@raspberrypi:~/Desktop/usb2cantest $
```

### 8.1.4 Run Python3 Demo

Download Python Demo named 'python3' from our Wiki and up-zip it to Desktop(or wherever you want put it ).

<https://github.com/INNO-MAKER/usb2can/tree/master/For%20Linux%20Raspbian%20Ubuntu/software>

There are three files in the 'c' folder. send.py and receive.py is for testing send and receive function separately and test.py is use for automatic testing.

(1) Check the Python version of your Raspbian. Python 3.7.3 default in 2019-09-26-Raspbian.img. Our Demo can run on any Python3 version.

```
python3 -V
```

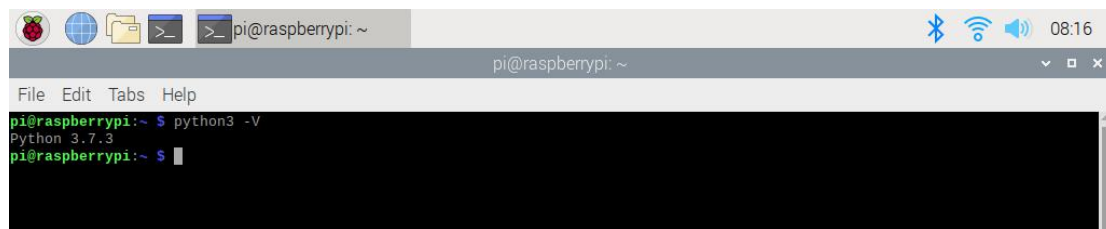

```
pi@raspberrypi: ~  
File Edit Tabs Help  
pi@raspberrypi:~$ python3 -V  
Python 3.7.3  
pi@raspberrypi:~$
```

(2) If you can't find the Python3 in system. Install the Python3

```
sudo apt-get install python3-pip
```

(3) If you are testing on Ubuntu system, It may can't use the 'ifconfig' command. Please install the net tools firstly.

```
sudo apt install net-tools
```

(4) Install Python CAN library.

```
sudo pip3 install python-can
```

(5) Run test code. One usb2can will send data and the other will print the result

```
sudo python3 test.py
```

(6) You will see the data received.

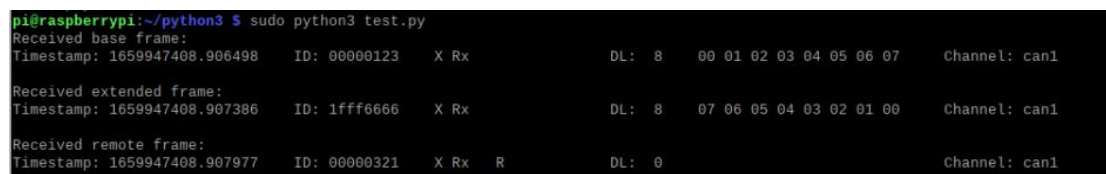

```
pi@raspberrypi:~/python3 $ sudo python3 test.py  
Received base frame:  
Timestamp: 1659947408.906498 ID: 0000123 X Rx DL: 8 00 01 02 03 04 05 06 07 Channel: can1  
Received extended frame:  
Timestamp: 1659947408.907386 ID: 1fff6666 X Rx DL: 8 07 06 05 04 03 02 01 00 Channel: can1  
Received remote frame:  
Timestamp: 1659947408.907977 ID: 0000321 X Rx R DL: 0 Channel: can1
```



## 8.2 Software Description

Now with previous demo's code to show you how to program socket can in Raspbian with C and Python . The socket can is an implementation of CAN protocols(Controllor Area Network) for Linux. CAN is a networking technology which has widespread use in automation, embedded devices, and automotive fields. While there have been other CAN implementations for Linux based on character devices, Socket CAN uses the Berkeley socket API, the Linux network stack and implements the CAN device drivers as network interfaces. The CAN socket API has been designed as similar as possible to the TCP/IP protocols to allow programmers, familiar with network programming, to easily learn how to use CAN sockets.

For more Socket CAN detail please refer to below link:

<https://www.kernel.org/doc/Documentation/networking/can.txt>

[https://elinux.org/CAN\\_Bus](https://elinux.org/CAN_Bus)

### 8.2.1 Programming in C

#### 8.2.1.1- For Sender's codes

(1): Create the socket, If an error occurs then the return result is -1.

```
/*Create socket*/  
s = socket(PF_CAN, SOCK_RAW, CAN_RAW);  
if (s < 0) {  
    perror("Create socket PF_CAN failed");  
    return 1;  
}
```

(2): Locate the interface to "can0" or other name you wish to use. The name will show when you execute `./ifconfig -a`.

```
/*Specify can0 device*/  
strcpy(ifr.ifr_name, "can0");  
ret = ioctl(s, SIOCGIFINDEX, &ifr);  
if (ret < 0) {  
    perror("ioctl interface index failed!");  
    return 1;  
}
```

(3): Bind the socket to "can0".

```
/*Bind the socket to can0*/
addr.can_family = PF_CAN;
addr.can_ifindex = ifr.ifr_ifindex;
ret = bind(s, (struct sockaddr *)&addr, sizeof(addr));
if (ret < 0) {
    perror("bind failed");
    return 1;
}
```

(4): Disable sender's filtering rules, this program only send message do not receive packets.

```
/*Disable filtering rules, this program only send message do not receive packets */
setsockopt(s, SOL_CAN_RAW, CAN_RAW_FILTER, NULL, 0);
```

(5): Assembly data to send.

```
/*assembly message data! */
frame.can_id = 0x123;
frame.can_dlc = 8;
frame.data[0] = 1;
frame.data[1] = 2;
frame.data[2] = 3;
frame.data[3] = 4;
frame.data[4] = 5;
frame.data[5] = 6;
frame.data[6] = 7;
frame.data[7] = 8;
//if(frame.can_id&CAN_EFF_FLAG==0)
if(!(frame.can_id&CAN_EFF_FLAG))
    printf("Transmit standard frame!\n");
else
    printf("Transmit extended frame!\n");
```

(6): Send message to the can bus. You can use the return value of write() to check whether all data has been sent successfully .

```
/*Send message out */
nbytes = write(s, &frame, sizeof(frame));
if(nbytes != sizeof(frame)) {
    printf("Send frame incompletely!\r\n");
    system("sudo ifconfig can0 down");
}
```

(7): Close can0 device and disable socket.

```
/*Close can0 device and destroy socket!*/
close(s);
```

### 8.2.1.2 -For Receiver's codes

(1) step 1 and (2) is same as Sender's code.

(3): It's different from Sender's.

```
/*Bind the socket to can0*/
addr.can_family = PF_CAN;
addr.can_ifindex = ifr.ifr_ifindex;
ret = bind(s, (struct sockaddr *)&addr, sizeof(addr));
if (ret < 0) {
    perror("bind failed");
    return 1;
}
```

(4): Define receive filter rules, we can set more than one filter rule.

```
/*Define receive filter rules, we can set more than one filter rule!*/
struct can_filter rfilter[2];
rfilter[0].can_id = 0x123; //Standard frame id !
rfilter[0].can_mask = CAN_SFF_MASK;
rfilter[1].can_id = 0x12345678; //extend frame id!
rfilter[1].can_mask = CAN_EFF_MASK;
```

(5): Read data back from can bus.

```
nbytes = read(s, &frame, sizeof(frame));
```

## 8.2.2 Programming in Python3

### 8.2.2.1- Import

#### import os

The OS module in Python provides a way of using operating system dependent functionality. The functions that the OS module provides allows you to interface with the underlying operating system that Python is running on – be that Windows, Mac or Linux. We usually use `os.system()` function to execute a shell command to set CAN.

#### import can

The python-can library provides Controller Area Network support for Python, providing common abstractions to different hardware devices, and a suite of utilities for sending and receiving messages on a CAN bus.

For more information about python-can, please to below link:

<https://python-can.readthedocs.io/en/stable/index.html>

#### ifconfig

If you are use Ubuntu system, It may can't use the 'ifconfig' command. Please install the net tools.

```
sudo apt install net-tools
```

### 8.2.2.2 -Simple common functions

(1) Install Python CAN library.

```
sudo pip3 install python-can
```

(2)Set bitrate and start up CAN device. Shut down the CAN down before setting the it.Otherwise the setting will be failed.

```
os.system('sudo ifconfig can0 down')
```

```
os.system('sudo ip link set can0 type can bitrate 1000000')
```

```
os.system("sudo ifconfig can0 txqueuelen 100000")
```

```
os.system('sudo ifconfig can0 up')
```

```
os.system('sudo ifconfig can1 down')
```

```
os.system('sudo ip link set can1 type can bitrate 1000000')
```

```
os.system("sudo ifconfig can1 txqueuelen 100000")
```

```
os.system('sudo ifconfig can1 up')
```

(3) Bind the socket to can0 and can1

```
can0 = can.interface.Bus(channel = 'can0', bustype = 'socketcan')
```

```
can1 = can.interface.Bus(channel = 'can1', bustype = 'socketcan')
```

(4) Assembly data to send.

```
sff frame = can.Message(arbitration_id=0x123, data=[0,1,2,3,4,5,6,7])
```

(5) Can0 send data.

```
can0.send(msg)
```

(6) CAN1 receive data. May I draw your attention that you should open a new thread to received.

```
msg = can1.recv(30.0)
```

(7) Close CAN device

```
os.system('sudo ifconfig can0 down')
```

```
os.system('sudo ifconfig can1 down')
```

## 9. BUSMASTER On Windows

BUSMASTER is an Open Source Software tool to Simulate, Analyze and Test data bus systems such as CAN. It seem stop to update now, but it also a great tools for reference.

Home Page:

<https://rbei-etas.github.io/busmaster/>

Project:

<https://github.com/rbei-etas/busmaster>

Video for BUSMASTER:

<https://www.youtube.com/user/busmasteropensource/featured>

### 9.1 Download and Install

(1)Download the from our github:

<https://github.com/INNO-MAKER/usb2can>

INNO-MAKER Added Coreboard hardware usermanual	1f56b1a 1 hour ago	🕒 22 commits
 Busmaster	add discription	6 months ago

(2) unzip the installation package and setup

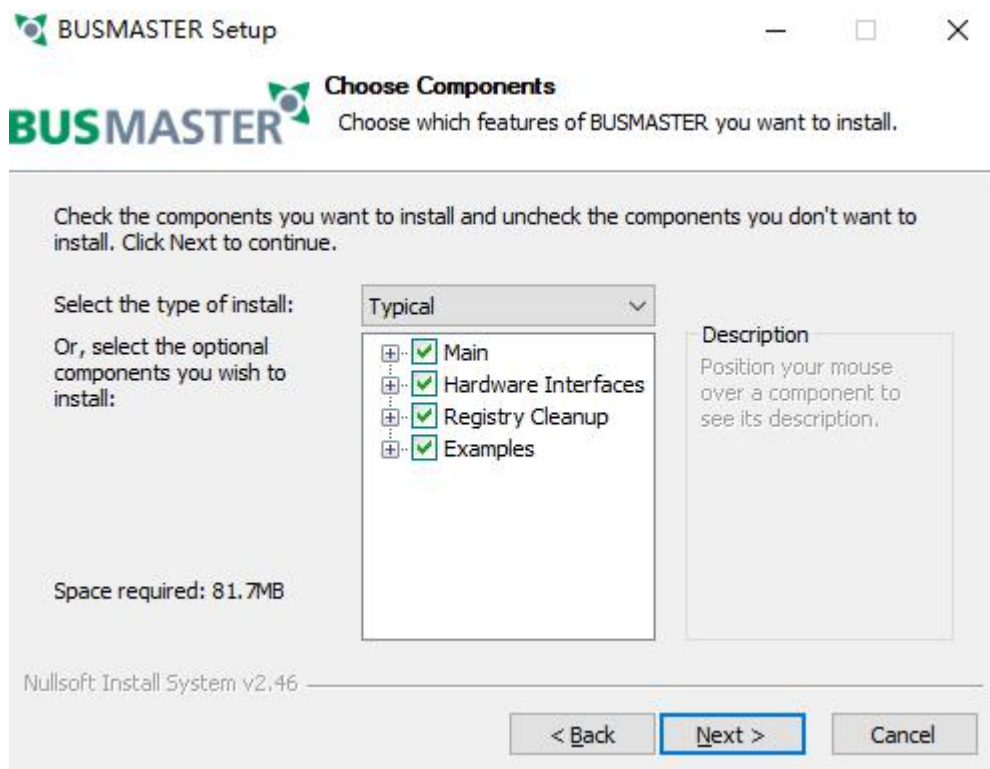
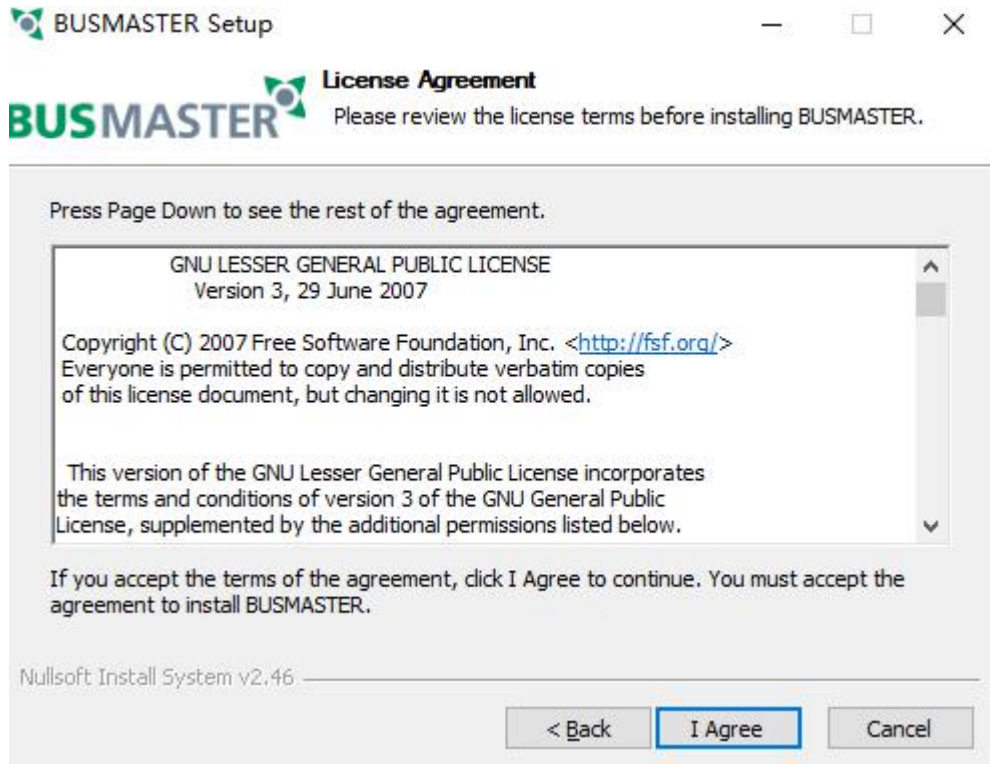



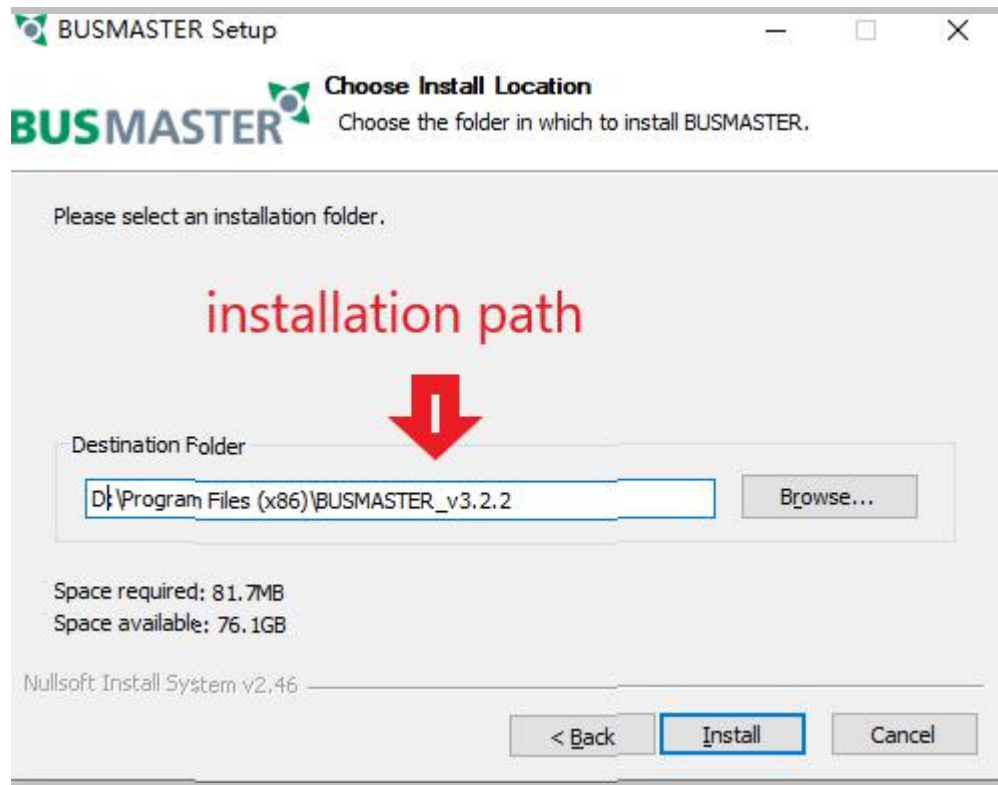

(3) unzip below service pack and past these three files into the installation path of BUSMASTER v3.2.2. Replace the files in the target.

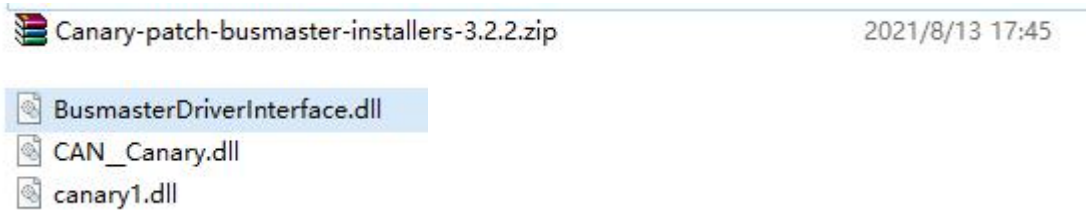



## 9.2 Using The Software

- (1) Open the BUSMASTER v3.2.2 and plug the usb2can into the usb port of your computer.
- (2) Click the 'driver selection' and select the 'Canary'

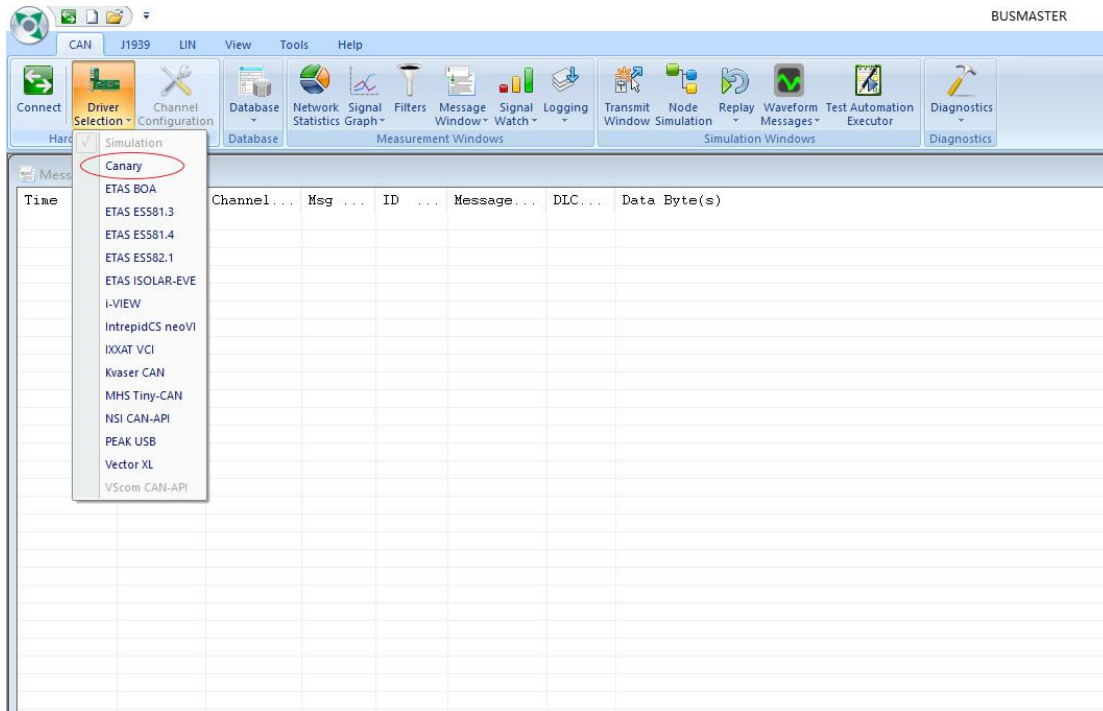

- (3) Setting the Baudrate, and press OK

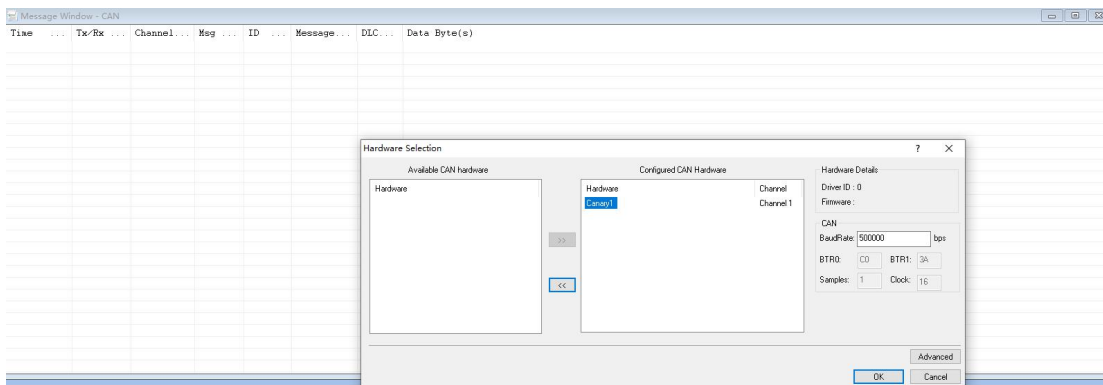

(4) Click connect, start to work.



## 10. Error Frame

You may receive some error frame marked in red when you use the USB2CAN module. They will let you know what problem does the USB2CAN module meet on your CAN Bus.

Some people would say why didn't they meet the error frame with other tool or USB to CAN module before. The truth is that most of the tool filter out the error frame to avoid controversy and support. They just show nothing when there are some error on the CAN Bus. We want to show the all raw data to help you to analyze your CAN BUS. Some error can be ignored, but some error maybe the hidden danger for your CAN BUS.

For the error frame ID description, please refer to below link:

<https://github.com/linux-can/can-utils/blob/master/include/linux/can/error.h>

Now we take a simple case to show you how to analyze the error frame ID. I made the incorrect connection between the USB2CAN module and the CAN Bus, to see what happens.

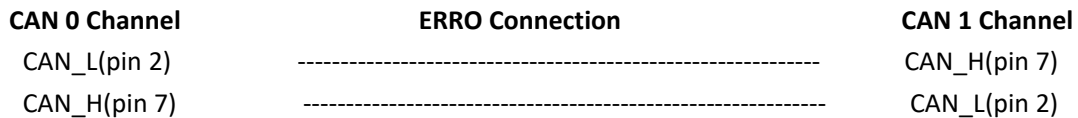

SeqID	SystemTime	Channel	Dirac...	FrameId	Frame...	Frame...	Length	FrameData
4	2020/6/29 14:44:08	0	Recv	0x20000024	Data ...	Stand ...	8	0x 00 00 00 00 00 00 00 00
5	2020/6/29 14:44:08	0	Recv	0x20000024	Data ...	Stand ...	8	0x 00 00 00 00 00 00 00 00
6	2020/6/29 14:44:08	0	Recv	0x20000024	Data ...	Stand ...	8	0x 00 00 00 00 00 00 00 00
7	2020/6/29 14:44:08	0	Recv	0x20000024	Data ...	Stand ...	8	0x 00 00 00 00 00 00 00 00
8	2020/6/29 14:44:08	0	Recv	0x20000024	Data ...	Stand ...	8	0x 00 00 00 00 00 00 00 00
9	2020/6/29 14:44:08	0	Recv	0x20000024	Data ...	Stand ...	8	0x 00 00 00 00 00 00 00 00
10	2020/6/29 14:44:08	0	Recv	0x20000024	Data ...	Stand ...	8	0x 00 00 00 00 00 00 00 00
11	2020/6/29 14:44:08	0	Recv	0x20000024	Data ...	Stand ...	8	0x 00 00 00 00 00 00 00 00
12	2020/6/29 14:44:08	0	Recv	0x20000024	Data ...	Stand ...	8	0x 00 0C 00 00 00 00 00 00
13	2020/6/29 14:44:08	0	Recv	0x20000024	Data ...	Stand ...	8	0x 00 0C 00 00 00 00 00 00
14	2020/6/29 14:44:08	0	Recv	0x20000024	Data ...	Stand ...	8	0x 00 0C 00 00 00 00 00 00
15	2020/6/29 14:44:08	0	Recv	0x20000024	Data ...	Stand ...	8	0x 00 0C 00 00 00 00 00 00
16	2020/6/29 14:44:08	0	Recv	0x20000024	Data ...	Stand ...	8	0x 00 30 00 00 00 00 00 00

As Above, We received error frame Id: 0x20000024 and 2 set of 8 byte Frame Data:

data[0]=0x00, data[1]=0x0C, data[3] to data[7] are all 0x00 .

data[0]=0x00, data[1]=0x30, data[3] to data[7] are all 0x00 .

According to the above error frame ID description link:

```

/* error class (mask) in can_id */
#define CAN_ERR_TX_TIMEOUT    0x00000001U /* TX timeout (by netdevice driver) */
#define CAN_ERR_LOSTARB      0x00000002U /* lost arbitration / data[0] */
#define CAN_ERR_CRTL         0x00000004U /* controller problems / data[1] */
#define CAN_ERR_PROT         0x00000008U /* protocol violations / data[2..3] */
#define CAN_ERR_TRX          0x00000010U /* transceiver status / data[4] */
#define CAN_ERR_ACK          0x00000020U /* received no ACK on transmission */
#define CAN_ERR_BUSOFF       0x00000040U /* bus off */
#define CAN_ERR_BUSERROR     0x00000080U /* bus error (may flood!) */
#define CAN_ERR_RESTARTED    0x00000100U /* controller restarted */

```

This Error frame ID = 0x20000000 | 0x00000020 | 0x00000004  
= 0x20000000 | CAN\_ERR\_ACK | CAN\_ERR\_CRTL

So the USB2CAN meet two problem **‘received no ACK on transmission’** and **‘controller problems’**.

For problem **‘received no ACK on transmission’** may case by the not CAN-BUS or other module on the CAN BUS are only listen mode(No ACK).

For problem **‘controller problems’**, refer to the data[1] description:

```

/* error status of CAN-controller / data[1] */
#define CAN_ERR_CRTL_UNSPEC    0x00 /* unspecified */
#define CAN_ERR_CRTL_RX_OVERFLOW 0x01 /* RX buffer overflow */
#define CAN_ERR_CRTL_TX_OVERFLOW 0x02 /* TX buffer overflow */
#define CAN_ERR_CRTL_RX_WARNING 0x04 /* reached warning level for RX errors */
#define CAN_ERR_CRTL_TX_WARNING 0x08 /* reached warning level for TX errors */
#define CAN_ERR_CRTL_RX_PASSIVE 0x10 /* reached error passive status RX */
#define CAN_ERR_CRTL_TX_PASSIVE 0x20 /* reached error passive status TX */
/* (at least one error counter exceeds */
/* the protocol-defined level of 127) */
#define CAN_ERR_CRTL_ACTIVE    0x40 /* recovered to error active state */

```

data[1] = 0x0C = 0x04 | 0x08 = CAN\_ERR\_CRTL\_RX\_WARNING | CAN\_ERR\_CRTL\_TX\_WARNING  
It means the USB2CAN module can't send/receive data properly and reached warning level.

data[1] = 0x30 = 0x10 | 0x20 = CAN\_ERR\_CRTL\_RX\_PASSIVE | CAN\_ERR\_CRTL\_TX\_PASSIVE  
It means the USB2CAN module can't send/receive data too much, USB2CAN module into error status.

Summing up the above, the error frame tell us, USB2CAN module can't get ACK from CAN BUS and can't send data to the CAN Bus. So the CAN Bus may not inexistence or the connection error.

## 11. User Manual Version Descriptions

Version	Description	Date	E-mail
V1.1		2019.02.02	<a href="mailto:support@inno-maker.com">support@inno-maker.com</a> <a href="mailto:sales@inno-maker.com">sales@inno-maker.com</a>
V1.2	Add Python Add can-utils	2019.08.26	<a href="mailto:calvin@inno-maker.com">calvin@inno-maker.com</a>
V1.3	Correct description	2019.08.26	<a href="mailto:calvin@inno-maker.com">calvin@inno-maker.com</a>
V1.4	Added DB9 Description Added CAN utils tools loopback mode description	2020.10.11	<a href="mailto:calvin@inno-maker.com">calvin@inno-maker.com</a>
V1.5	Added description for how to install net tools on Ubuntu system	2021.05.01	<a href="mailto:calvin@inno-maker.com">calvin@inno-maker.com</a>
V1.6	Added USB2CAN-DEVKIT ,USB2CAN-Cable,USB description Merged Mas Os , WINDOWS, LINUX description	2021.10.10	<a href="mailto:calvin@inno-maker.com">calvin@inno-maker.com</a>
V1.7	Added Dimension Figure Added Chapter BUSMASTER ON WINDOWS	2022.01.06	<a href="mailto:calvin@inno-maker.com">calvin@inno-maker.com</a>
V1.8	Merge USB2CAN-x2 doc Update Python3 description Add MINIPCIE-CAN description	2022.08.08	<a href="mailto:calvin@inno-maker.com">calvin@inno-maker.com</a>

If you have any suggestions, ideas, codes and tools please feel free to email to me. I will update the user manual.