

flowering until it is exposed to prolonged period of low temperature of the winter. The requirement of low temperature treatment for accelerating flowering is called **vernalization**.

The site of vernalization in the case of biennials and perennials, is believed to be the growing point (apical bud). Cold treated shoot apices when grafted on to untreated plants induce the latter to flower. This property is attributed to cold induced production of a stimulus called vernalin. But vernalin remains as a hypothetical substance and has never been isolated from plants. The plant hormone gibberellic acid can substitute the effect of low temperature treatment for germination, flowering and release of bud dormancy in many plants.

Vernalization effect is reversible and the reverse process is called devernalsation. If a vernalized seed or plant is kept under high temperature, the effect of low temperature treatment is completely removed. High temperature reversal can be counteracted if the duration of vernalization treatment is increased. Devernalsated plants can, however, be vernalized under low temperature treatment.

#### 14.9. PHOTOPERIODISM :

It is the phenomenon of physiological changes that occur in plants in response to relative length of day and night (i.e. photoperiod). The response of the plants to the photoperiod, expressed in the form of flowering is also called as photoperiodism. Garner and Allard (1920) noticed that Soybeans and Tobacco could be made to flower only if the plants were exposed to a series of short days. After a series of experiments they realized the importance of relative length of the day as a chief factor of importance for growth and development of plants.

Most plants can flower only if they are exposed to the light for less or more than a certain period, called **critical period** (Fig. 14.12). Depending on the photoperiod, the plants are classified into three categories:

**(a) Short Day Plants (SDP) :** These plants are exposed to photoperiod shorter than a critical period i.e. a relatively short day light period (usually 8-10 hours) and a continuous dark period of about 14-16 hours for subsequent flowering. These plants are also known as long-night plants e.g. Rice, coffee, soybean, tobacco and chrysanthemum.

In SDPs, the dark period is critical and should be continuous. If this dark period is interrupted even with a flash of light, the plants will not flower.

**(b) Long Day Plants (LDP) :** These plants require longer day light period (usually 14-16 hours) i.e. light period for more than the critical period for subsequent flowering. These plants are also called as short night plants. E.g. Wheat, radish, cabbage, sugar beet and spinach.

**(c) Day Neutral Plants (DNP):** These plants flower in all photoperiod and do not show any correlation between exposure to light duration and flowering response. E.g. Tomato, cotton, sunflower, cucumber, peas and certain varieties of tobacco.

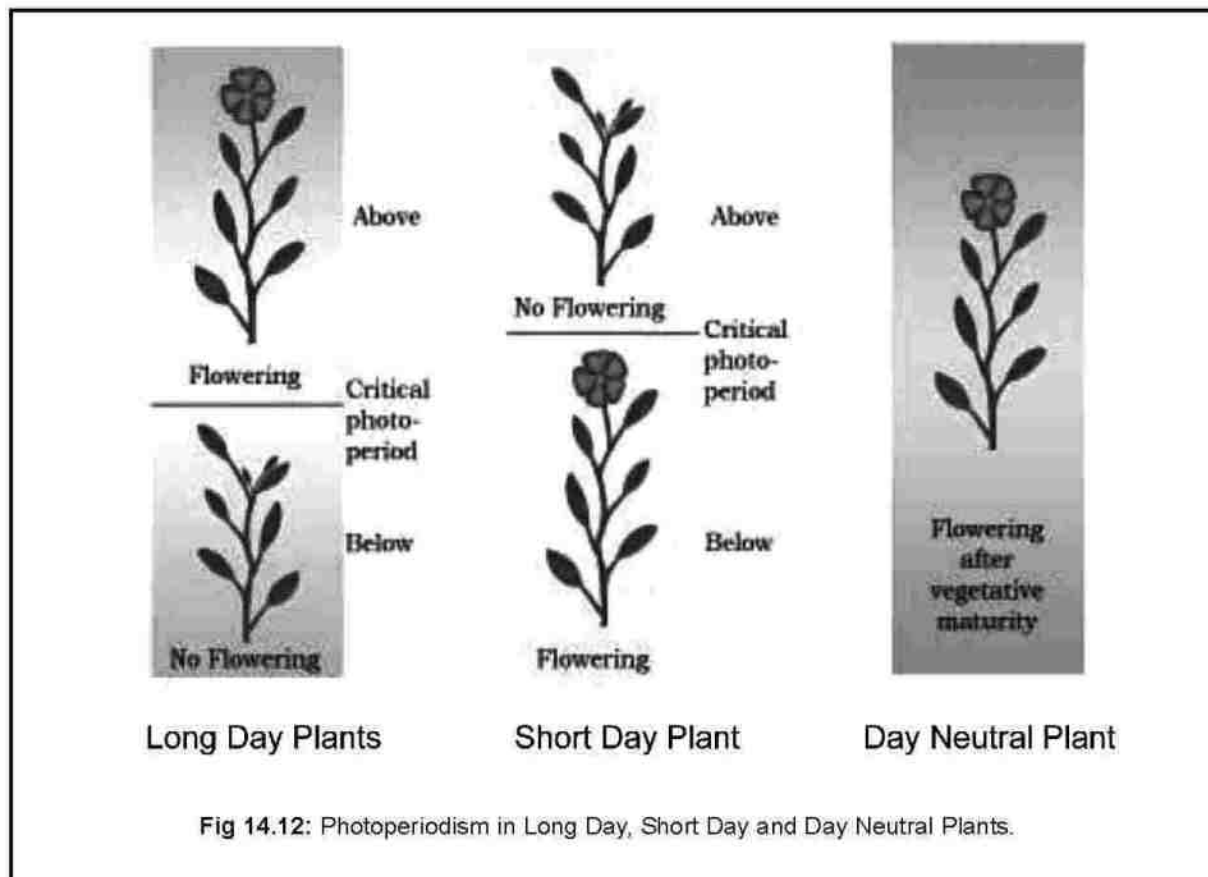

The inhibition of flowering in short day plants by brief exposure of red light and stimulation of flowering in long day plants by the interruption of dark period involves the operation of a proteinaceous pigment called **phytochrome**.

Leaves are the sites of perception of light or dark period in plants. It is presumed that there is a hormonal substance called **florigen** which is responsible for flowering. When required photo-inductive period is given, the florigen synthesized and migrates from leaves to shoot apices to induce flowering in plants.

Photoperiodism is a process of physiological preconditioning. This has been of great importance to the commercial flower growers. They can be able to induce or retard the flowering by regulating the light and dark periods in controlled conditions to meet the market demand.

## SAMPLE QUESTIONS

### A. Multiple-choice questions :

- Gibberellic acids do which of the following physiological effects:  
(a) yellowing of young leaves  
(b) elongation of genetically dwarf plants  
(c) shortening of genetically tall plants  
(d) yellowing of old leaves
- What will happen when the dark period of short day plants is interrupted by a flash of light?  
(a) flowers immediately (b) will not flower  
(c) induce more flowering (d) converts to a long day plant
- The plant hormone connected primarily with cell division is:  
(a) IAA (b) NAA  
(c) Kinetin (d) GA
- Apical dominance is influenced by:  
(a) GA (b) Ethylene  
(c) Auxin (d) Coumarine
- Abscisic acid causes:  
(a) stomatal closure (b) leaf expansion  
(c) root formation (d) stem elongation
- Richmond-Lang effect is due to :  
(a) auxin (b) abscisic Acid  
(c) cytokinin (d) ethylene
- Auxin transport is  
(a) polar (b) non-polar  
(c) symplastic (d) apoplastic

### B. Fill in the blanks :

- Fruit ripening is induced by the hormone \_\_\_\_\_.
- Mangrove plants generally show \_\_\_\_\_ type of germination.
- Florigen is associated with \_\_\_\_\_.
- The amino acid \_\_\_\_\_ is the precursor of ethylene.

### C. Short answer type:

- Growth curve
- Apical dominance
- Seed dormancy
- Vernalization

### D. Long answer type :

- Describe the different types of seed germination.
- Give an account of physiological effects of auxins in plants.
- Discuss the physiological effects of gibberellins in plants.



## UNIT-V : HUMAN PHYSIOLOGY

### DIGESTION AND ABSORPTION

#### CHAPTER

#### 15

Organisms need food for their survival. It provides energy and inorganic and organic materials required for growth, repair of tissues and other purposes. The major bio-macromolecules present in our food are carbohydrates, proteins and lipids. Besides, minerals and vitamins are also present in food, which are needed by our body in small quantities. Water is very much essential for us as it constitutes about 55% of our body mass and is used in various metabolic processes. We get all these molecules from the food, we eat by a process called **ingestion**. The complex bio-macromolecules are then hydrolyzed into simple absorbable products by a process called **digestion**. The digested products pass into the blood or body fluid for distribution to all parts of the body. This process is called **absorption**. Cells and tissues, in all parts of the body, pick up the required amount of these nutrients from the blood or body fluid by a process called **assimilation**. Finally the residual undigested food is eliminated by **defaecation** or **egestion**. The sum total of all the above-mentioned five processes is known as **nutrition**. *Thus, nutrition may be defined as a process by which an organism takes in or ingests food, hydrolyzes or digests it, absorbs and finally assimilates the digested food into the body and lastly eliminates the undigested residual food by egestion or defaecation.* A part of the food is used as substrate for generation of energy by catabolism. Any excess of it is stored in the cells of storage organs, especially the liver, muscle and adipose tissue for use during exigency.

#### 15.1. BIOMACROMOLECULES :

**Carbohydrates** : These have the general molecular formula  $C_n(H_2O)_n$  and are classified into monosaccharides (e.g. glucose, fructose and galactose), oligosaccharides (e.g. maltose, lactose and sucrose) and polysaccharides (e.g. starch, glycogen and cellulose). These constitute the key source of energy for the body. The end products of carbohydrate digestion are monosaccharides, mostly glucose. The main sources of carbohydrates are rice, wheat, maize and potato.

**Proteins** : These are made up of many of the twenty different amino acids. The amino acids are joined linearly by peptide bonds to form long polypeptide chains. Animal sources of proteins are milk, egg, fish, meat etc. and plant sources include pulses, nuts, peas, beans etc. The proteins are hydrolyzed into amino acids at the end of digestion.

**Lipids** : These are water insoluble organic compounds, which mostly consist of oils and fats. They serve as the storage or reserve source of energy during exigency. The principal sources of dietary lipids are vegetable oils, vegetable or vanaspati ghee and animal fat or neutral fat. Most lipids are digested into fatty acids and glycerol.

**Nucleic Acids** : DNA and RNA constitute an insignificant part of our food. During digestion they are converted first into nucleotides and then into nitrogenous bases, pentose sugar and phosphate.

**15.2. TYPES OF DIGESTION :**

Digestion is of two types based on the place of occurrence: **Intra-cellular** and **extra-cellular**.

**15.2.1. Intra-cellular digestion (Fig.15.1) :**

It is the simplest type of digestion, which occurs entirely inside the cell. The food material is engulfed by the cell into a **food vacuole**. Then **lysosomes** containing digestive enzymes fuse with the food vacuole and consequently the food is digested. The digested products are absorbed into the surrounding cytoplasm by simple diffusion. The residual undigested food is eliminated to the outer side by **egestion** (e.g.; all protozoa, sponges and *Hydra*).

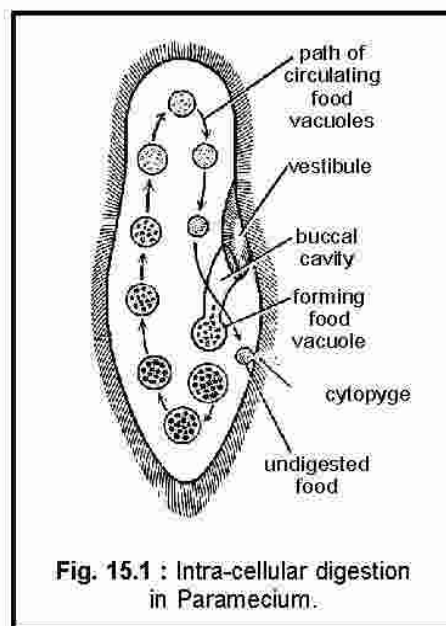

**Fig. 15.1 :** Intra-cellular digestion in Paramecium.

**15.2.2. Extra-cellular digestion :**

Here, the food is digested in the extra-cellular space i.e. the lumen of a digestive tract or gut. It is a more complex process, in which digestive enzymes are secreted by specialized digestive glands and released into the lumen of the gut to digest the complex micromolecular food. This type of digestion is a characteristic feature of animals included in the phyla from coelenterata to Chordata including human.

Coelenterates and some worms combine both types of digestion.

**DIFFERENCES BETWEEN INTRACELLULAR AND EXTRACELLULAR DIGESTION**

Intracellular	Extracellular
1. Digestion occurs inside cells.	1. Digestion occurs outside the cell i.e. in the extracellular space or the lumen of the alimentary canal.
2. Food vacuoles are formed in the process.	2. No food vacuole is formed.
3. Digested food diffuses into the cytoplasm.	3. Digested products are absorbed into the body fluid such as lymph and blood.
4. Digestive enzymes are released into the food vacuoles by the lysosomes of the surrounding cytoplasm.	4. Digestive enzymes are secreted into the lumen of the gut by specialized digestive glands.

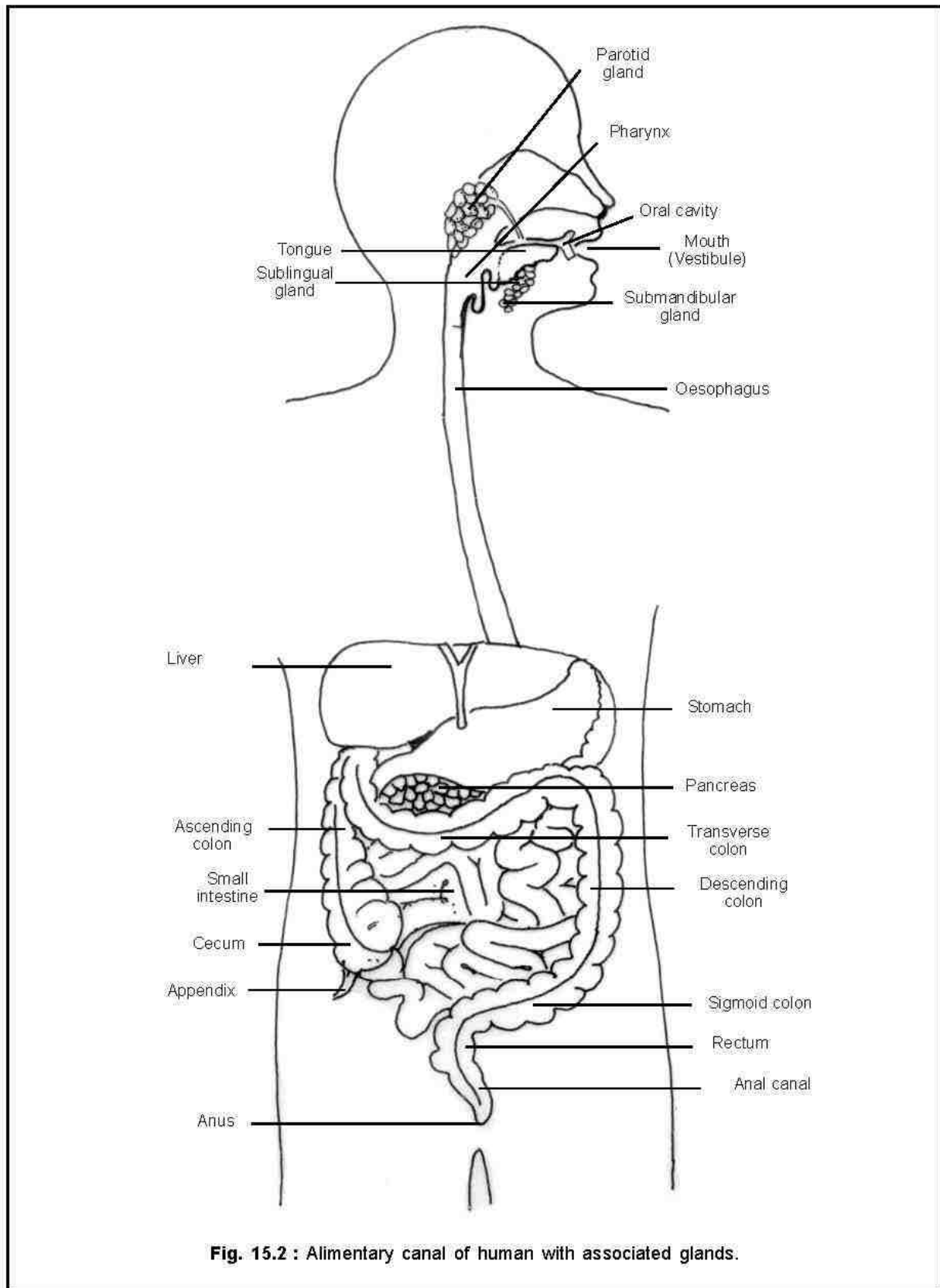

**Fig. 15.2 :** Alimentary canal of human with associated glands.

### 15.3. DIGESTIVE SYSTEM OF HUMAN :

The digestive system includes a long and differentiated **alimentary canal** and **associated glands** (Fig.15.2). The alimentary canal performs diverse functions such as **ingestion**, temporary storage **digestion** and **absorption** of food and elimination of undigested residue, known as the **faecal matter** or **stool**. The associated glands secrete digestive juice containing enzymes and other elements. The enzymes hydrolyze complex food materials into simple molecules that are easily absorbed into the body fluid (blood and lymph) for transport to all parts of the body and then assimilated by the cells.

#### 15.3.1. Alimentary Canal :

The alimentary canal of human being is a long coiled tube having distinct regional parts. There is a variation in the diameter of the tube in different regions. It consists of: **(1) Mouth; (2) Buccal cavity or Oral cavity; (3) Pharynx; (4) Oesophagus; (5) Stomach; (6) Small intestine; (7) Large intestine; (8) Rectum; (9) Anal canal; and (10) Anus.**

Besides the alimentary canal, there are two associated glands : **(1) Liver;** and **(2) Pancreas.**

**Mouth :** The mouth is a transverse slit, bounded by two soft and movable lips. It is meant for the ingestion of food. It opens into a **vestibule**. The vestibule in turn, opens into a **buccal cavity** or **oral cavity**. The buccal cavity is closed and opened by a pair of jaws, a lower and upper. The jaws bear teeth.

**15.3.2.1. Buccal cavity or Oral cavity :** It is a large space bound dorsally by a **palate**, ventrally by the throat and in front by the jaws having teeth. The cavity is lined by **stratified squamous epithelium**. It has the following structures.

**(a) Palate :** Palate forms the roof of the buccal cavity and separates the buccal cavity from the nasal chamber. It is differentiated into anterior, **hard palate** and posterior, **soft palate**. The hard palate is provided with transverse ridges, called **palatine ridges** or **rugae**. The rugae help in securing a better grip on the food. The soft palate is smooth and fleshy. The posterior free part of the soft palate hangs down as a small, conical flap, the **uvula** or **velum palati**, which closes the internal nares during swallowing of food.

**(b) Tongue :** The tongue is a freely movable, muscular gustatory organ, situated on the floor of the oral cavity. Its base is fixed, but the tip is free and is protrusible. It is attached to the floor of the mouth cavity by a membrane called **frenulum**.

The upper surface bears **taste buds** situated on **taste papillae**. The papillae are connected by nerves.

#### (i) Taste papillae and Taste buds

The papillae are small projections found on the upper surface of the tongue. There are three types of papillae, namely, **filiform;** **fungiform;** and **circumvallate** (Fig.15.3).

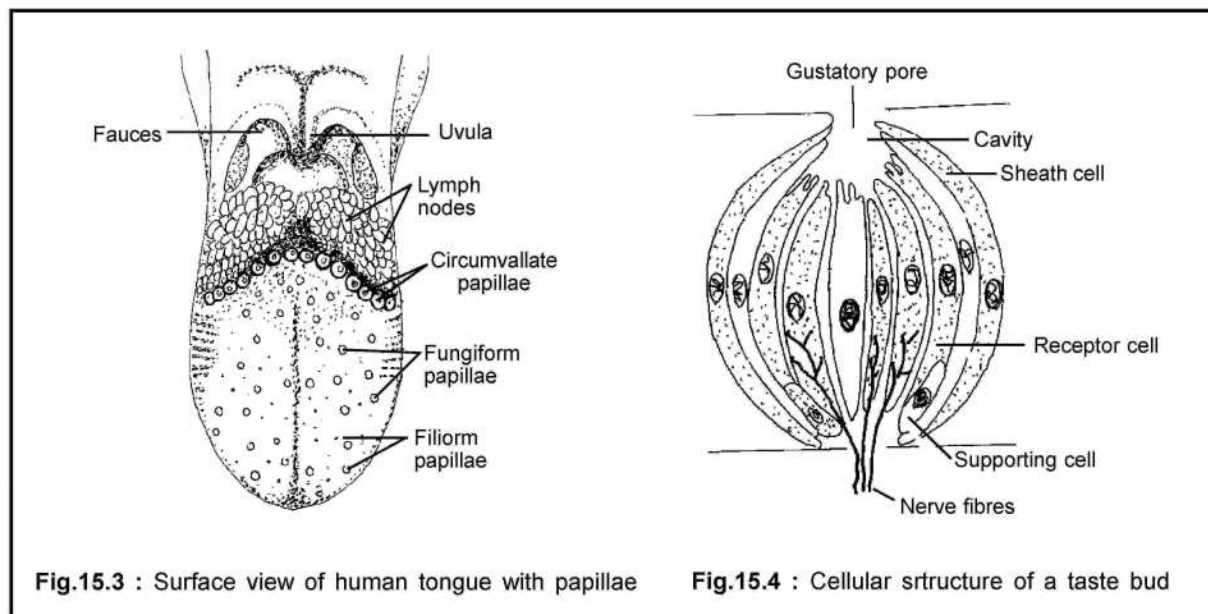

1. **Filiform papillae** : These are small, conical and most numerous, present on anterior two-third part of the tongue. These papillae do not bear taste buds.
2. **Fungiform papillae** : These are mushroom-shaped papillae and less numerous than filiform papillae, distributed on the tip and along the sides of the tongue. Each fungiform papilla bears up to five taste buds, situated at the tip.
3. **Circumvallate papillae** : These are large and circular papillae, few in number (8-12), lying along the margin of an inverted **V-shaped sulcus terminalis** near the base of the tongue. Each circumvallate papilla is encircled by a deep furrow, which bears the taste buds. Each papilla bears up to 100 taste buds, lying along the wall of the furrow.

The taste buds are the organs of taste. Besides the tongue, taste buds are also present on the soft palate, epiglottis, palatoglossal arches and posterior wall of the oropharynx. A taste bud is a pyriform structure made up of modified epithelial cells (Fig. 15.4). There is a small cavity that opens to the surface through a **gustatory pore**. Contrary to previously held idea that taste buds perceiving different tastes, such as sweet, sour, bitter and salty are specialized, it is undoubtedly established that all taste buds can perceive all tastes.

#### (ii) Functions of the tongue

1. It functions as a gustatory organ (an organ perceiving taste).
2. It helps in the act of chewing and mastication of the food.
3. It helps in the act of swallowing.
4. It plays a role in speech.



5. It acts as a brush to clean the teeth.
6. It keeps the mouth moist by secreting mucous and serous fluids.

(c) **Teeth** : Teeth are present on both jaws in the oral cavity. Human teeth are **theodont** in nature i.e. the roots are lodged in bony sockets of the jaw bones. All the teeth of the upper jaw are lodged in sockets of maxilla bones and of the lower jaw in sockets of the dentary bones.

The number of teeth is fixed for a species and so is for human being. They develop in two sets : **milk** or **deciduous set** and **permanent set** (Fig. 15.5). The milk teeth appear during first 2 years after birth. These are smaller, weaker and temporary. They are replaced by the permanent teeth between 6 to 12 years of age. The teeth that appear in two sets are called **diphyodont**. The deciduous set consists of two incisors, one canine and two premolar teeth on each side of the upper and lower jaws. Permanent teeth of man are of four types, based on their functions : **incisors (8)**, **canines (4)**, **premolars (8)** and **molars (12)** (Fig. 15.5). This is called **heterodont dentition**.

Incisors are present in the anterior part of the jaw. They have sharp cutting edges and hence, are called cutting teeth. The canines are pointed and are dagger-shaped. Premolars and molars are called **grinding** or **cheek teeth** having **cusps** or **grinding surfaces**. They are located farther back on the jaws. All the molars grow in the permanent set only. Thus, molars appear only once in the life time and therefore, they are **monophyodont**. The last molars are called **wisdom teeth**.

#### (i) Dental Formula

The numerical presentation showing the number and arrangement of teeth in one half of both the jaws is called **dental formula**. On adding all the teeth in one half of both the jaws, the number is multiplied by two. The resultant is the total number of teeth.

##### Dental Formula (permanent set)

$$= I \frac{2}{2}, C \frac{1}{1}, PM \frac{2}{2}, M \frac{3}{3} \times 2 = 32 \text{ or } \frac{2123}{2123} \times 2 = 32$$

##### Dental Formula (Deciduous set)

$$= I \frac{2}{2}, C \frac{1}{1}, PM \frac{2}{2}, M \frac{0}{0} \times 2 = 20 \text{ or } \frac{2102}{2102} \times 2 = 20$$

(N.B: I, Incisor; C, Canine; PM, Premolar; and M, Molar)

#### (ii) Structure of Tooth

A typical tooth consists of three regions: (i) **crown**, (ii) **neck**, and (iii) **root** (Fig.15.6). The crown is the exposed part of the tooth. Neck is usually covered by **fleshy gum** or

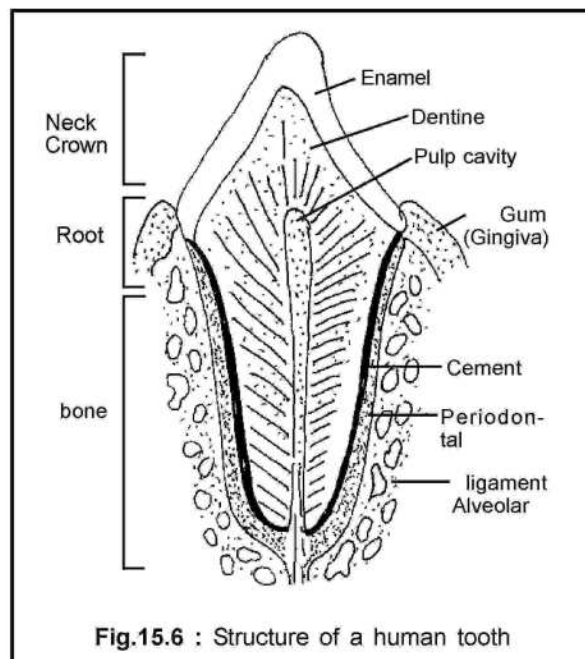
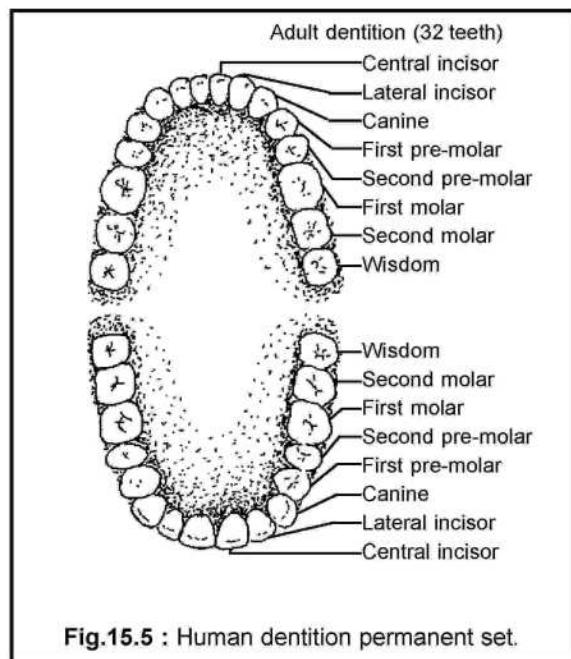

**gingiva.** Root is embedded in a socket of the jaw bone. The root consists of one, two or three **fangs**. For example, an incisor and a canine, each have a single fang or root; upper molar has three roots; and lower molar two roots.

The main mass of a tooth consists of a hard and bone-like material, without blood vessels, called **dentine**. It is chiefly composed of phosphate and carbonate of calcium and magnesium and collagen fibers. In the region of the crown, the dentine is covered by a much harder shiny-white material called **enamel**. It is composed of large amount of calcium phosphate and organic substance. **Enamel is the hardest substance in the body.** The dentine is covered by a thin layer of cement in the root region. The cement adheres to the wall of the bony socket through a layer of fibrous connective tissue. The dentine is traversed by a **pulp cavity** containing a mass of cells, blood vessels and nerve endings that constitute a connective tissue, known as the **pulp**.

#### (d) Salivary glands

There are three pairs of salivary glands in human, namely, (a) **parotid** (b) **sublingual** and (c) **submaxillary** or **submandibular**. The ducts open into the oral or buccal cavity (Fig. 5.13). The glands secrete a watery, secretion called saliva into the oral cavity.

**15.3.1.2. Pharynx :** It is a continuation of the buccal or oral cavity behind. There is no physical demarcation between the two and therefore, the two often constitute a **bucco-pharyngeal cavity**. The nasal canals and the buccal cavity, both open into the pharynx. It is divided into three sections: (i) **nasopharynx** (ii) **oropharynx** and (iii) **laryngopharynx**.

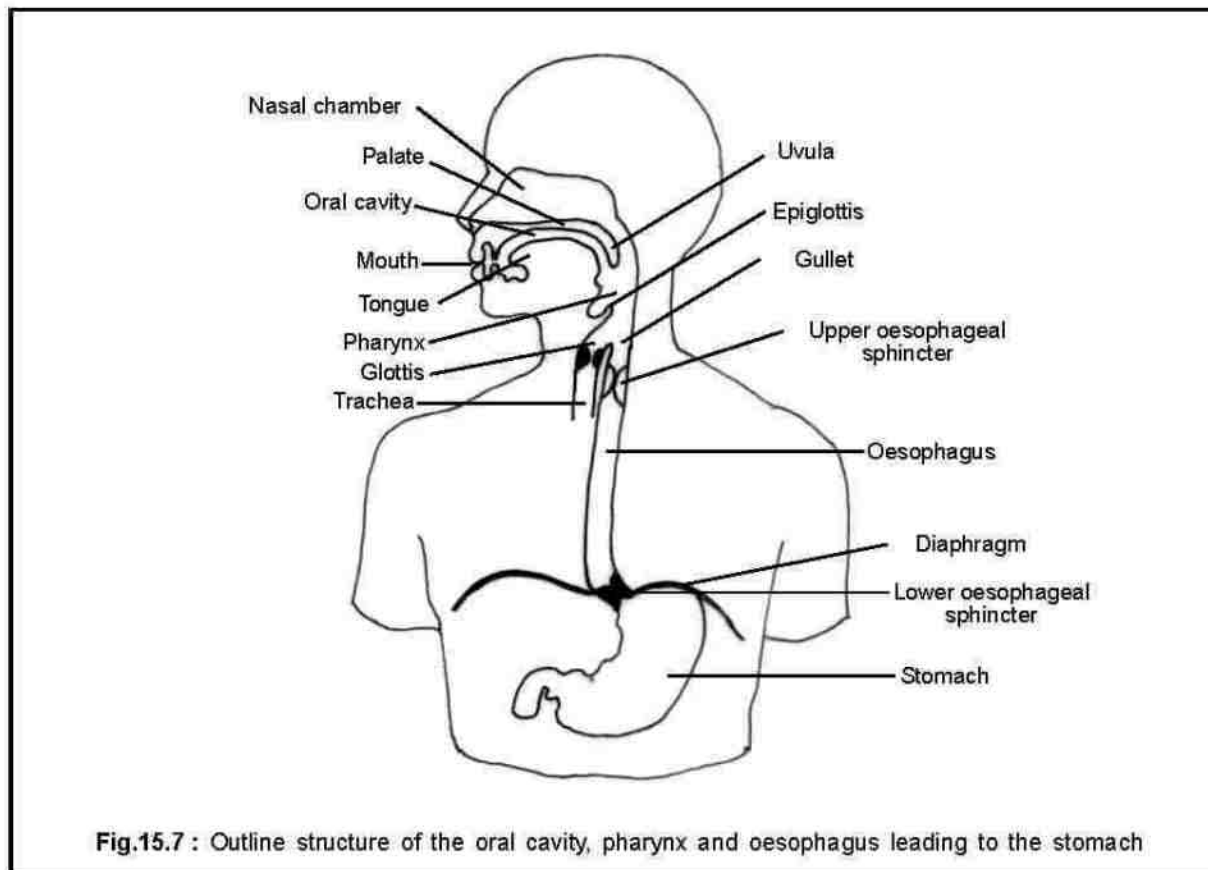
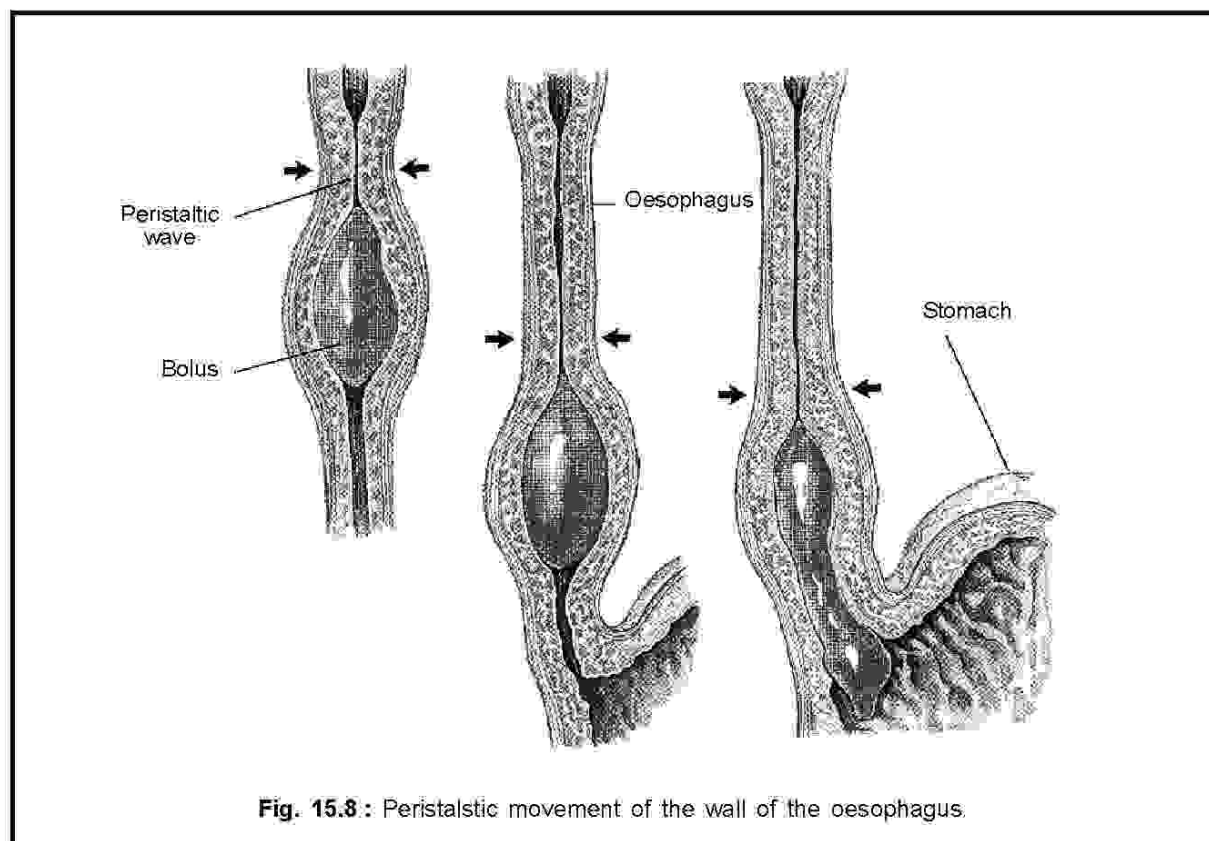

**Fig.15.7 :** Outline structure of the oral cavity, pharynx and oesophagus leading to the stomach

**(a) Nasopharynx :** The nasal canals open into a section of the pharynx, called the nasopharynx, through a pair of **internal nostrils** or **internal nares**. It serves for the passage of the inspired and expired air. There is a pair of small oval openings, called **openings of eustachian tubes**, on the roof. Each middle ear opens into the nasopharynx through an eustachian tube.

**(b) Oropharynx :** The buccal cavity opens into a section of the pharynx, called oropharynx. It serves as the passage for food.

**(c) Laryngopharynx :** Both the naso-and oropharynx open into a short laryngopharynx. The laryngopharynx, in turn, opens into the oesophagus or food pipe through **gullet** and into the larynx or the sound box through a **glottis**. The larynx is continued into the trachea or the wind pipe. The food pipe and the wind pipe cross each other at the end of the laryngopharynx. The glottis is guarded by a muscular flap called **epiglottis**. When we swallow the food, the glottis remains closed by the epiglottis. The presence of an epiglottis guarantees that the food and air enter into their respective pipes. A mass of lymphoid tissues, called **palatine tonsil**, lies on either side of oropharynx. Infection of tonsils by pathogenic microorganisms causes their inflammation. This pathological condition is known as **tonsillitis**.



**Fig. 15.8 :** Peristaltic movement of the wall of the oesophagus.

**15.3.1.3. Oesophagus :** It is a 25 cm long, narrow muscular tube lined internally by stratified squamous epithelium containing mucous secreting gland cells. It runs downward from the gullet through the neck behind the trachea, passes through the diaphragm and opens into the stomach in the abdomen. The mucosa (the innermost tissue layer) is raised into longitudinal folds, called **oesophageal rugae**. One each of two such folds is present at the beginning and the end, which regulate the entry and exit of food from the oesophagus. These folds are called **oesophageal sphincters** (Fig. 15.7). The oesophagus conducts the food to the stomach by successive contraction and relaxation of the muscle layers of the oesophageal wall. This phenomenon is known as **peristalsis** (Fig. 15.8). The contraction and relaxation in a reverse rhythm is known as **antiperistalsis**. It results in rhythmic **hiccups**.

**15.3.1.4. Stomach :** The stomach is a large J-shaped distensible sac-like muscular organ present on the upper left side of the abdomen, just below the diaphragm. It is about 30 cm long and 15 cm wide. It has a variable capacity ranging from 2.0 to 4.5 liters. It communicates in front with the oesophagus and behind with the first part of the small intestine, the duodenum. The stomach has four regions : (i) **cardiac region** (cardia); (ii) **fundus**; (iii) **body**; and (iv) **pyloric region** [Fig.15.9 (a)]. The pyloric region begins with a somewhat widened part, called **pyloric antrum**. It leads into a short and narrow **pyloric canal** that ends in a **pyloric sphincter**. Each of these parts contains a specific type of gland.

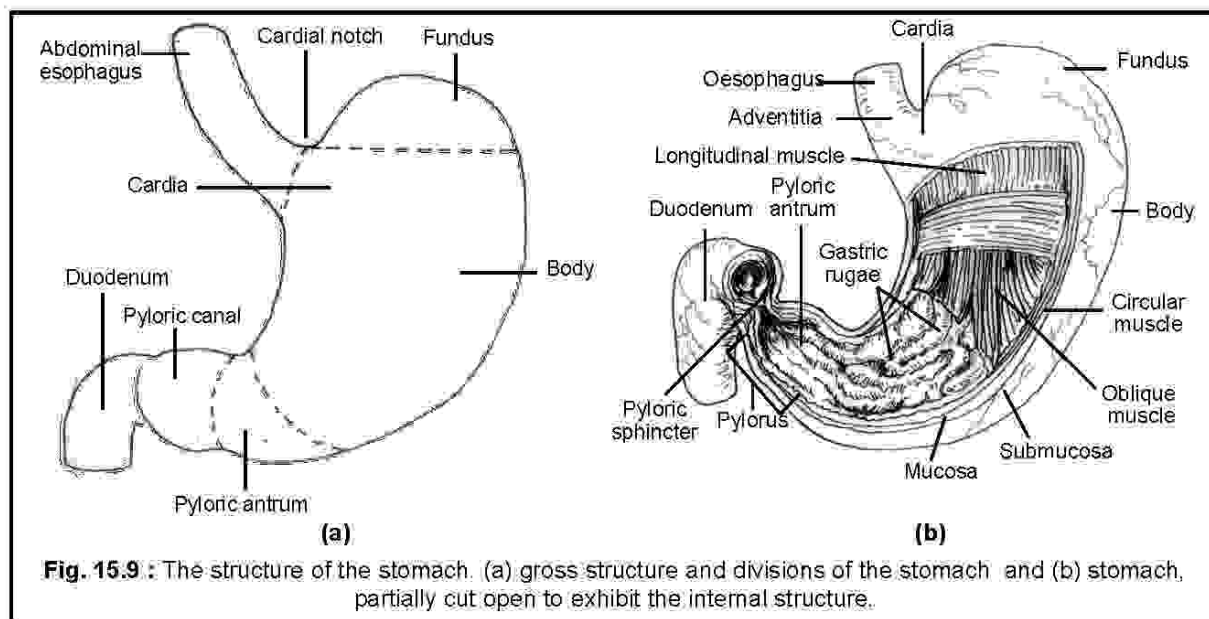

**Fig. 15.9 :** The structure of the stomach. (a) gross structure and divisions of the stomach and (b) stomach, partially cut open to exhibit the internal structure.

**(a) Cardiac part (Cardia) :** The oesophagus drains the food into the cardiac stomach through a cardiac aperture. It is guarded by a sphincter, the **lower oesophageal sphincter** or **cardiac sphincter** (Fig. 15.7), which prevents backward movement of the food into oesophagus.

**(b) Fundus :** It is the thickest part, lying to the left of cardiac aperture. It has a dome like upper part that projects above the cardiac aperture.

**(c) Body :** It is the main and middle part of the stomach.

**(d) Pyloric part (Pylorus) :** It is the narrow lower part of the stomach, which opens into the duodenum by a pyloric aperture, guarded by a **pyloric sphincter**. The pyloric sphincter regulates the passage of food into the duodenum.

**(e) Functions of the stomach**

1. It stores food temporarily, received from the oesophagus.
2. It helps in mechanical mixing of food, known as **churning**.
3. It helps in the digestion of food by enzyme.
4. It regulates the flow of food into the small intestine.
5. Some **enteroendocrine cells** in the mucosa of the stomach (antrum part) secrete a hormone, called **gastrin**. It regulates the secretion of gastric juice from the gastric glands. Some other cells secrete another hormone, called **motilin**, which promotes the smooth muscle contraction in the wall of the stomach and intestine. This hormone is also produced from the mucosa of the small intestine and colon.

**15.3.1.5. Small Intestine:** It is the longest part of the alimentary canal, measuring about seven meters. It extends from the end of the pyloric stomach to the **ileo-caecal valve** guarding the caecum. It is divided into three parts : **duodenum, jejunum, and ileum.**

**(a) Duodenum :** It is the proximal part and is about 25 cm long. It forms a C-shaped curve. The common bile duct and the pancreatic duct open into the duodenum, marked by an **ampulla of Vater**. The opening is guarded by a **sphincter of Oddi**.

**(b) Jejunum :** It is the middle part of the small intestine. It follows the duodenum and is about 2.5 meters long.

**(c) Ileum :** It is the distal part of small intestine. It is the longest part and is about 3.5 meters

long. It opens into the **caecum** of the large intestine. The opening of the ileum into the caecum is guarded by an **ileo-caecal valve**, which prevents the passage of food into the caeum. The jejunum and ileum are profusely coiled structures. Small intestine is the region where most of the digestion and absorption of food takes place.

**(d) Peyer's Patches :** Small nodules of lymphoid tissue are present along the lining through out the entire length of the small intestine. In the ileum, the nodules are clustered together in groups called **Peyer patches** or **Gut Associated Lymphoid Tissues (GALT)**. These are the places for maturation of bone marrow lymphocytes as B-lymphocytes. Though less conspicuous, lymph nodes are found throughout the length of the small intestine.

**(e) Functions of small Intestine**

1. It completes the digestion of food.
2. It helps absorb nutrients into blood and lymph.
3. It secretes gastro-intestinal hormones, such as, secretin; and cholecystokinin-pancreozymin, which regulate the release of bile and pancreatic juice, respectively into the duodenum.
4. The Peyer's patches serve as the maturation sites for B-lymphocytes, which mature as antibody secreting plasma cells.

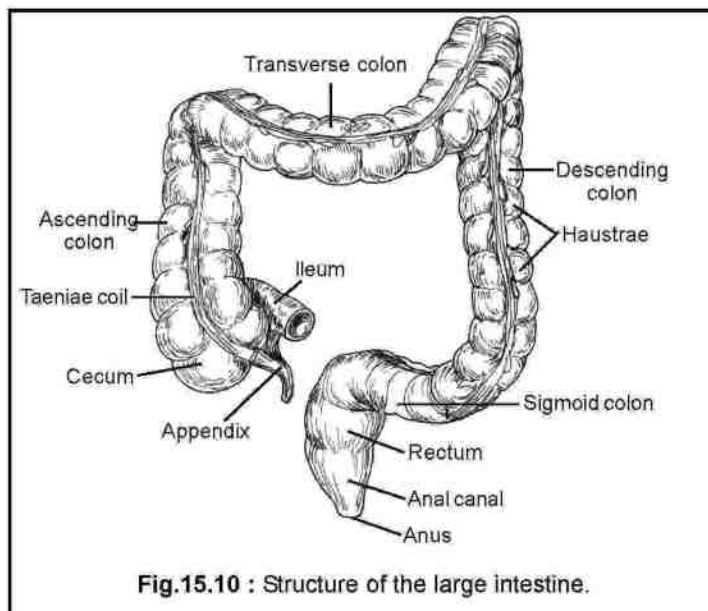

**Fig.15.10 :** Structure of the large intestine.

**15.3.1.6. Large Intestine :** The large intestine is shorter than the small intestine. It measures about 1.5 meters long. It is much wider than the small intestine and is divided into three parts: **caecum**, **colon** and **rectum** (Fig.5.10). The colon has three longitudinal muscle strips or chords, called **taeniae coli**. The contractions of the taeniae coli form small pouches called **haustreae** or **haustras**.

**(a) Caecum :** It is a small, blind sac measuring about 6 cm in length and 7.5 cm in width. The caecum is extended as a small and finger shaped tubular structure called **vermiform appendix** (Fig.5.10). The appendix is a vestigial organ in human being. Occasionally, the appendix develops inflammation due to microbial infection. This pathological condition is known as **appendicitis**. In such cases, the infected appendix is removed surgically. Both the caecum and vermiform appendix are quite large and more developed in herbivores. Cellulose digesting bacteria harbour the appendix and help digest the cellulose, which the herbivores eat in bulk.

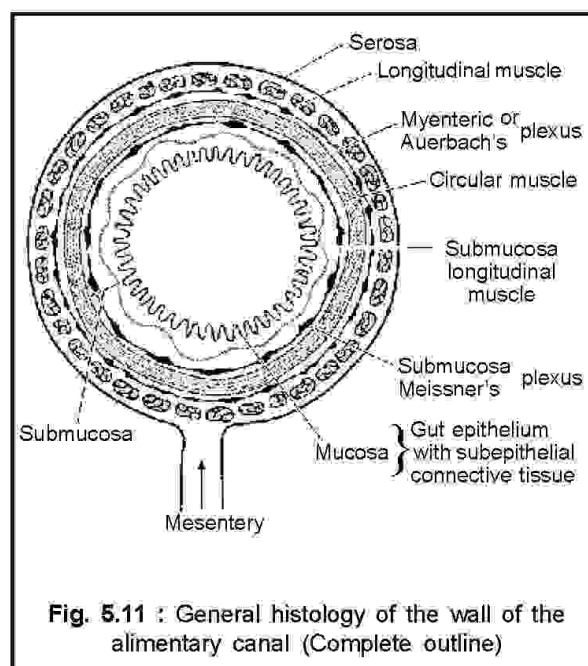

**Fig. 5.11 :** General histology of the wall of the alimentary canal (Complete outline)

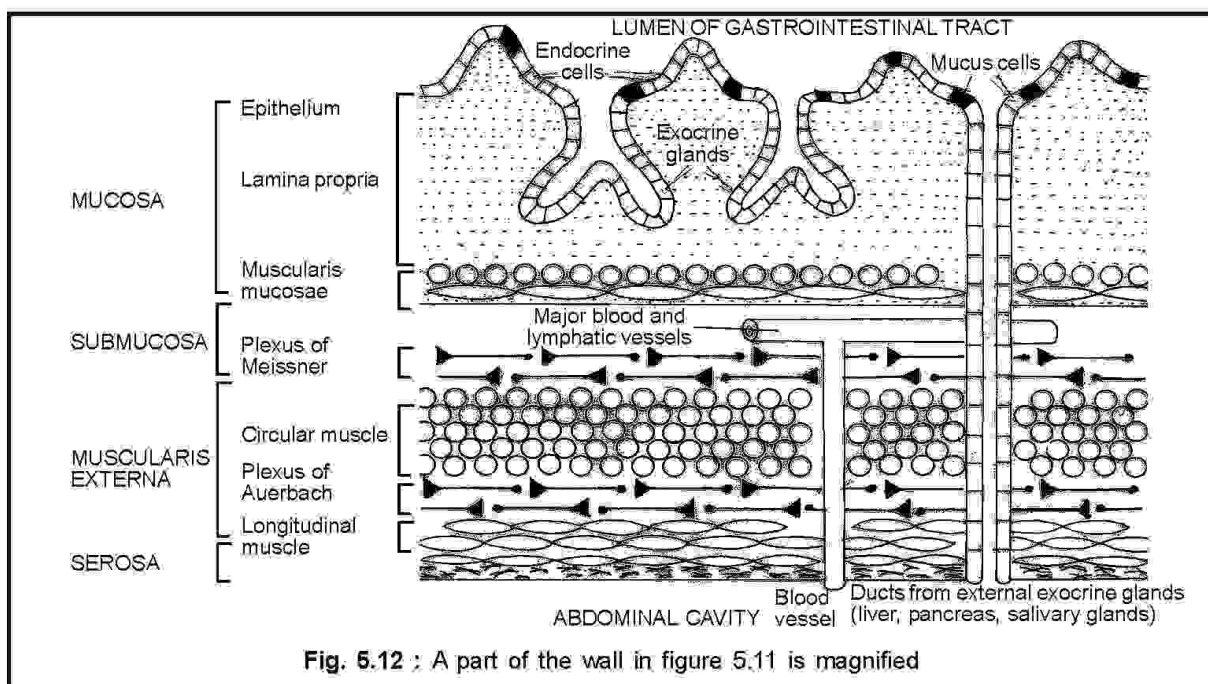

**Fig. 5.12 :** A part of the wall in figure 5.11 is magnified

**(b) Colon :** It is the longest part of the large intestine. It is about 130 cm long and accumulated possessing pouches. It is differentiated into four regions : **ascending colon** extending up to the liver on the right side; **transverse colon** that bends to the left and crosses the abdominal cavity below the pancreas; **descending colon** running downward on the left side; and **sigmoid** or **pelvic colon** that runs to the right and joins the rectum (Fig. 15.10).

**(c) Rectum :** It is about 16 to 20 cm long. It is concerned with temporary storage of the faecal matter. The rectum has longitudinal folds which dilates it during storage. Its lower part is prolonged as an **anal canal**, which finally opens to the exterior through an **anal orifice** or **anus**, guarded by an **anal sphincter**.

#### **(d) Functions of Large Intestine**

1. It receives and temporarily stores undigested residual food from the small intestine.
2. It absorbs water and salts.
3. It provides a site for the action of bacteria that release the food substance and produce vitamins and gases.

**15.3.1.7. Anus :** The anus is guarded by **internal** and **external anal sphincters**. The enlargement of rectal veins in the wall of the anus causes a severe painful condition, called **haemorrhoid** or **piles**.

### **15.3.2. General Histology of the Alimentary Canal**

Histologically, the alimentary canal consists of four primary layers: (a) **outer most serosa** or **visceral peritoneum**; (b) **muscular layer**; (c) **submucosa**, and (d) **innemost lining of mucosa** [Figs. 15.12 (a) & (b)].

**(a) Serosa :** It is the outer most visceral peritoneal layer made up of simple squamous epithelium. It is called serosa because it is lubricated by a serous or watery fluid.

**(b) Muscular layer :** It is present below the serosa and is composed of outer **longitudinal** and inner **circular** muscle layers. Both the muscle layers consist of smooth and unstriated muscle cells. An oblique layer may be present in some parts. These muscle layers help in **peristalsis**.

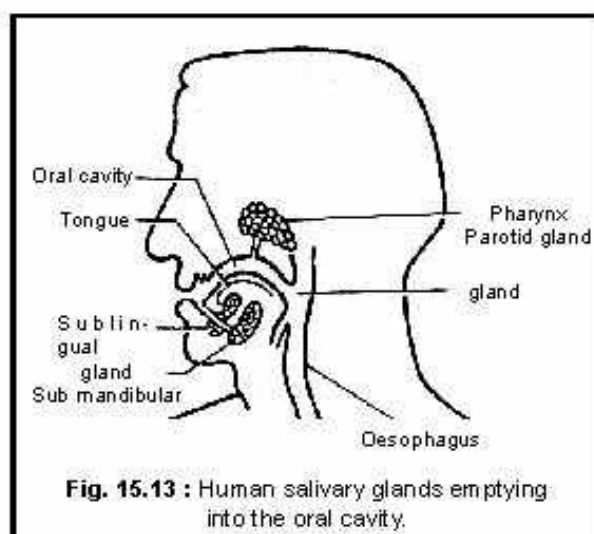

**Fig. 15.13 :** Human salivary glands emptying into the oral cavity.



(c) **Submucosa** : It lies between the muscular layer and mucosa. It consists of **loose connective tissue**, richly supplied with blood vessels and lymph vessels. In this layer, a nerve network, called **plexus of Meissner**, is present.

(d) **Mucosa** : This layer forms the inner most layer and it is named as mucosa because it secretes mucous to lubricate the inner lining of the gut. It is composed of three layers from outer to inner.

- (i) A **muscularis mucosa** of a thin muscular layer, consisting of outer longitudinal muscle layer and inner circular muscle layer.
- (ii) A middle thin layer of loose connective tissue called **lamina propria** or **tunica propria**. The tunica propria contains fine blood and lymph vessels.
- (iii) The inner most layer is the mucous membrane, made up of columnar epithelial cells supported by a thin basement membrane. It forms **gastric glands** in the stomach and **villi and intestinal glands** in the small intestine.

### 15.3.3. Digestive Glands :

These glands secrete digestive juices for the digestion of food. The glands involved in the digestion process and their secretions are enlisted below :

1. **Salivary glands** (Oral cavity) : Saliva
2. **Gastric glands** (Stomach) : Gastric juice
3. **Intestinal glands** (Small intestine) : Intestinal juice or Succus entericus.
4. **Brunner's glands** (Duodenum) : Mucous
5. **Pancreas** : Pancreatic juice
6. **Liver** : Bile

All, except bile from liver and mucous from Brunner's glands, contain one or more digestive enzymes. Bile does not contain any enzyme; but still plays an important role in digestion. Mucous hydrates and lubricates the food.

**15.3.3.1. Salivary Glands** (Fig.15.13) : There are three pairs of salivary glands in human.

(a) **Parotid Glands** : These are the largest of the salivary glands, located anterior and inferior to the external ear or pinna. The parotid ducts or **Stenson's ducts** open into the vestibule, opposite to the upper second molar teeth. Inflammation of parotid gland due to viral infection causes the disease called **mumps**.

(b) **Sublingual Glands** : These are smallest of the salivary glands, located below the tongue. They open at the floor of the buccal cavity by a number of small sublingual ducts or **Bartholin's ducts** or **ducts of Rivinus**.

(c) **Submandibular (Submaxillary) Glands** : These are located inferior to the mandible on the floor of the oral cavity. They open below the tongue, by **submaxillary** or **Wharton's ducts**.

The salivary glands secrete a viscous, watery fluid called saliva into the oral cavity. It contains a starch-hydrolyzing enzyme called **ptyalin** or **salivary  $\alpha$ -amylase**. Its pH is marginally in the acidic side i.e. 6.8. About 1.5 litres of saliva is secreted daily. The salivary  $\alpha$ -amylase hydrolyzes starch into **maltose**, **maltotriose** and **limit dextrin ( $\alpha$ -dextrin)**. A **lingual lipase** is also secreted by **Ebner's glands**, present on the dorsal side of the tongue. This lipase, although secreted from the buccal cavity, becomes active only in the stomach. Saliva also contains a **bacteriolytic enzyme**, **lysozyme** and **immunoglobulin A ( $I_gA$ )**. These two play an important role in the first line of defence of the body.

(d) **Composition of saliva**

**Water is about 99.5%**

**Total solids constitute 0.5%**

(i) **Cellular constituents**

Few desquamated epithelial cells, bacteria etc.

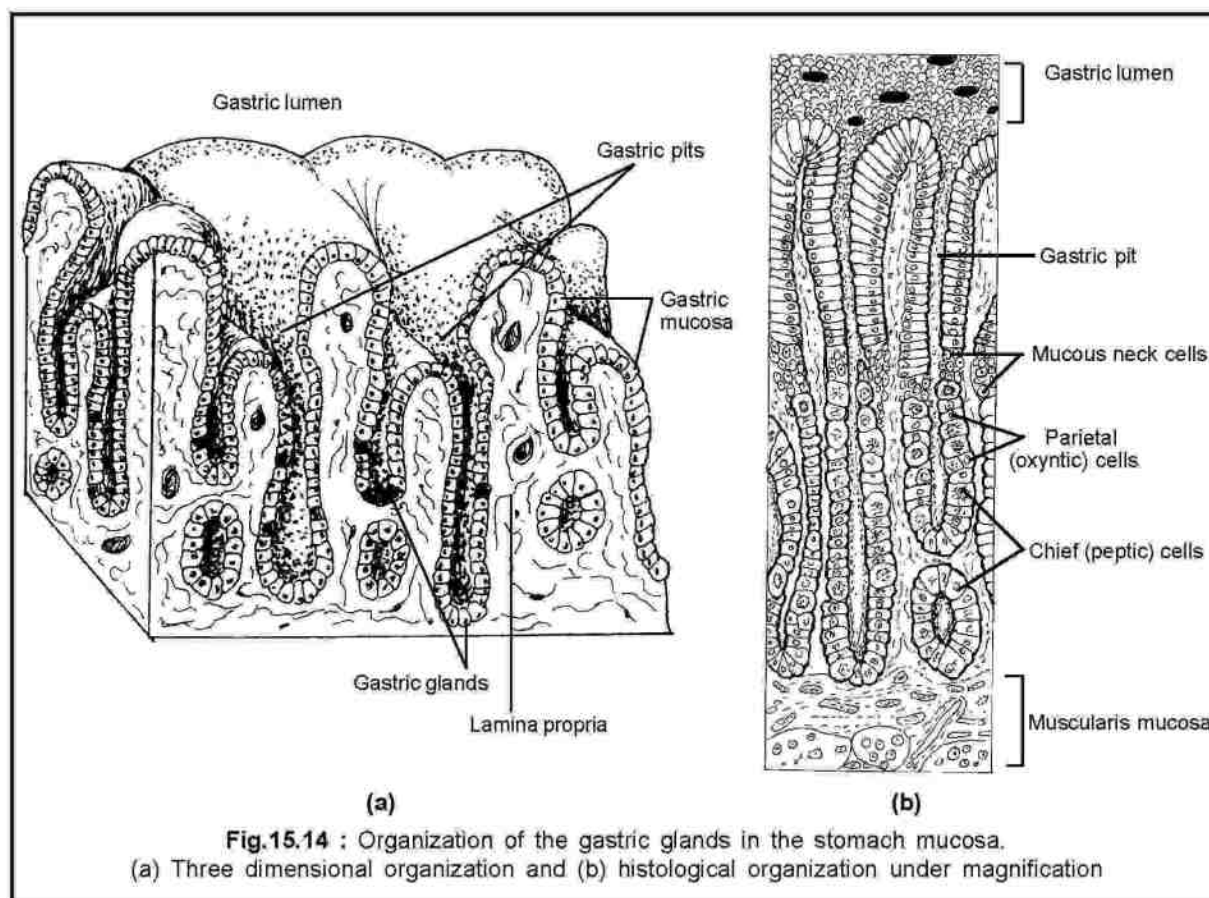

**Fig.15.14** : Organization of the gastric glands in the stomach mucosa.

(a) Three dimensional organization and (b) histological organization under magnification

(ii) **Inorganic constituents : 0.2%**

Important salts are Sodium chloride, Potassium chloride, Calcium carbonate, Calcium phosphate and Sodium bicarbonate.

(iii) **Organic constituents : 0.3%**

**Enzymes :** Salivary  $\alpha$ -amylase (Ptyalin), lingual lipase, phosphatase, and bacteriolytic enzyme (lysozyme).

**Other organic matter :**

Immunoglobulin A ( $I_gA$ ), mucin, urea, amino acids, cholesterol, etc.

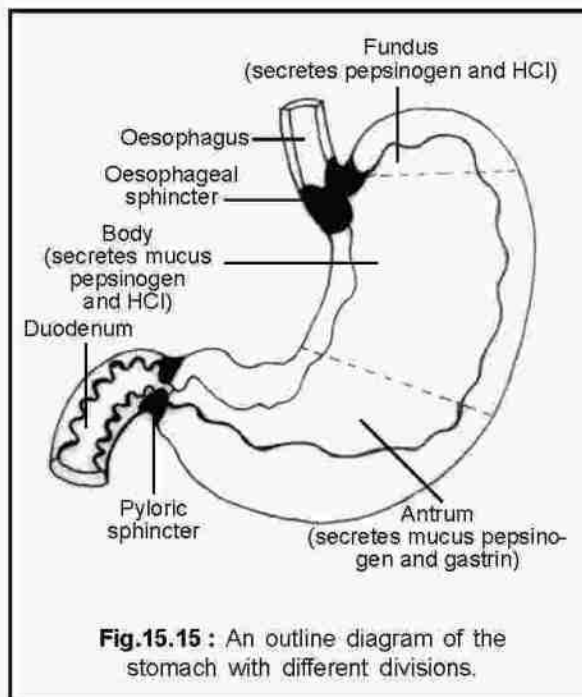

**Fig.15.15 :** An outline diagram of the stomach with different divisions.

**(e) Functions**

1. **Mechanical function :** Saliva keeps the mouth moist and helps in speech, masticates the food, prevents injury to the mucous membrane.

2. **Digestive function :** The enzyme ptyalin or salivary  $\alpha$ -amylase splits starch into maltose, maltotriose and limit dextrin.

3. **Bacteriolytic function :** Lysozyme of saliva has bactericidal property i.e. it kills bacteria by dissolving their polysaccharide cell wall.

4. **Contains an antibody, immunoglobulin A ( $I_gA$ ) :** It serves as the first line of defence of the body.

5. **Maintenance of water balance :** When body water is lost due to sweating, perspiration, diarrhoea, etc., saliva secretion is reduced and thirst sensation is aroused. Consequently, there is a stimulation for drinking more water to restore the water balance of the body.

6. **Excretory Function :** Saliva excretes urea; heavy metals like mercury, lead and arsenic; alkaloids like morphine; antibiotics such as penicillin and streptomycin; ethyl alcohol; thiocyanate; iodide; and some micro-organisms from the body.

**15.3.3.2. Gastric Glands :** The mucous membrane lining the stomach is well developed and is folded to form about 35 million simple or branched tubular glands called gastric glands [Fig.15.14 (a)]. These are of three types : cardiac glands, pyloric glands and fundic glands.

(a) **Cardiac Glands** : The cardiac glands are found in the cardiac region of the stomach, which secrete mucous, pepsinogen and HCl in traces.

(b) **Pyloric Glands** : They are found in the pyloric region, which secrete mucus as well as gastrin. It also secretes pepsinogen and HCl in traces.

(c) **Fundic Glands** [Fig. 15.14 (b)] : The gastric glands of the fundus are called fundic glands. Each fundic gland has three types of cells :

- (i) **Chief or peptic (zymogen) cells** secrete two pro-enzymes; **pepsinogen**, and **prorennin**, and an enzyme **gastric lipase**. They are usually present in the basal part of gastric glands.
- (ii) **Oxyntic (parietal) cells** secrete **hydrochloric acid**. These cells are large and are most numerous on the side walls of the gastric glands.
- (iii) **Mucous neck cells** or **Goblet cells** are numerous at the neck of the glands. They secrete a watery lubricating substance, the mucus.

The secretions of these cells collectively form the gastric juice. The gastric juice is strongly acidic with a pH of 0.9 to 1.5. Approximately, 500-1000 ml of gastric juice is secreted per meal (2-3 liters / day)

**Enterochromaffin cells** or **enteroendocrine cells** present in the mucosa layer of the pyloric antrum secrete a hormone, called **gastrin**. These cells are stimulated by the arrival of food (bolus) from the oesophagus. Consequently, gastrin is secreted, which stimulates the gastric glands to secrete gastric juice.

**15.3.3.3. Intestinal Glands** : There are two types of intestinal glands: **crypts of Lieberkuhn** or **intestinal glands** and **Brunner's glands** or **duodenal glands**.

A crypt of Lieberkuhn is a multicellular simple tubular gland (Fig.15.16), present throughout the small intestine between the villi. It is a sunken or invaginated part of the mucosa into the lamina propria. It contains three main types of cells: **goblet cells**; **Paneth (zymogen) cells** and **enteroendocrine**

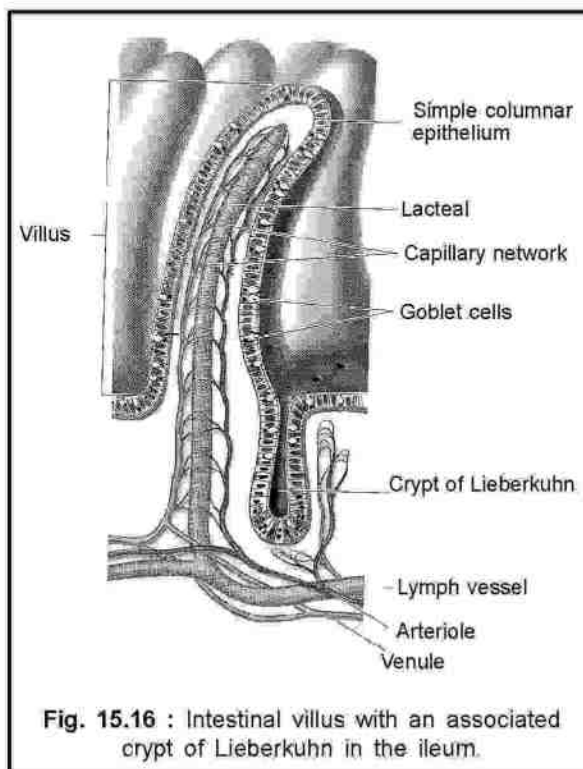
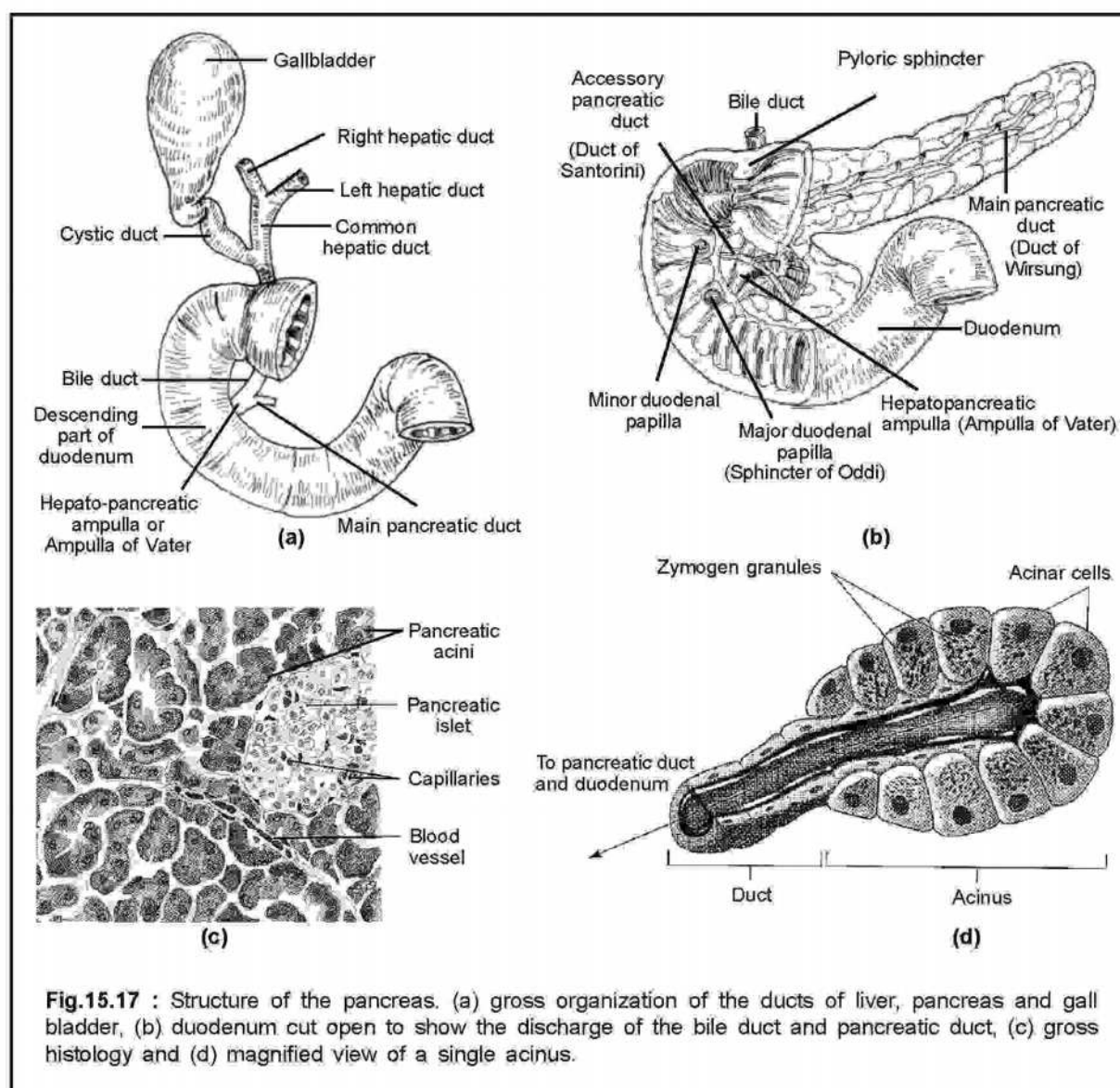

Fig. 15.16 : Intestinal villus with an associated crypt of Lieberkuhn in the ileum.

**(enterochromaffin) cells:** Goblet cells secrete mucous, while Paneth cells are believed to secrete lysozyme, an enzyme having anti-bacterial property. The enteroendocrine cells secrete several hormones, which regulate the secretion of gastric juice, pancreatic juice and bile. These hormones include **secretin**, **cholecystokinin-pancreozymin** and **gastric inhibitory peptide (GIP)**. The cells of the crypts also secrete a number of enzymes, which complete the process of digestion. Similar crypts are also present in the large intestine, which secrete only mucus, but no enzyme.

The **Brunner's glands** are multicellular glands, present in the submucosa of the duodenum only. They are absent in the jejunum and ileum. They secrete mucous to protect the intestinal lining from the corrosive action of hydrochloric acid. Brunner's glands open into the crypts of Lieberkuhn of the duodenum.



**Fig.15.17 :** Structure of the pancreas. (a) gross organization of the ducts of liver, pancreas and gall bladder, (b) duodenum cut open to show the discharge of the bile duct and pancreatic duct, (c) gross histology and (d) magnified view of a single acinus.

The secretion of intestinal glands is known as **intestinal juice** or **succus entericus**. About 2 to 3 litres of intestinal juice is secreted per day. The juice contains mucin and several enzymes such as **maltase**, **isomaltase**, **sucrase (invertase)**, **lactase**,  $\alpha$ - or **limit dextrinase ( $\alpha$ -1,6 glycosidase)**, **exopeptidases (aminopeptidase and carboxypeptidase)**, **endopeptidases**, **dipeptidases**, **nucleoside phosphorylase**, **nucleotidase** and **intestinal lipase**. These enzymes act on the partially digested food of the stomach. Intestinal juice also contains an activator enzyme called **enteropeptidase** or **enterokinase**, which activates inactive trypsinogen into active trypsin.

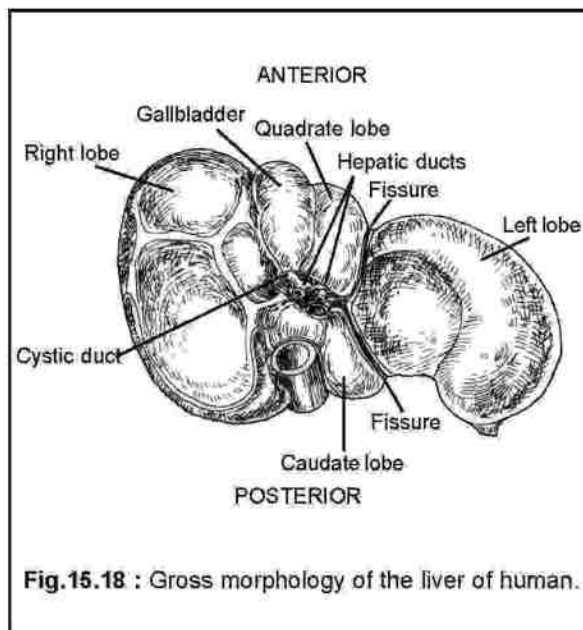

Fig. 15.18 : Gross morphology of the liver of human.

In addition to the digestive glands, the entire mucosa layer of the alimentary canal has mucous glands that produce mucus. The mucous lubricates the digestive tract so that food passes through easily. The mucous coat protects the underlying cells of the mucosa layer from the digestive enzymes.

**15.3.3.4. Pancreas** : It is a pinkish gland located in the loop of the duodenum and extends up to the spleen behind the stomach. It is about 2.5 cm wide and 12-15 cm long. It is comprised of three parts: head, body and tail. Pancreas is the second largest gland and it functions both as an **exocrine** and an **endocrine gland**. Thus, it is a **mixocrine gland**. Its exocrine part is formed by large number of **lobules** or **acini** [Figs. 15.17 (c) & (d)]. Each acinus consists of a number of glandular cells, which secrete **pancreatic juice**. Pancreatic juice is carried by the pancreatic duct or **duct of Wirsung** [Figs. 15.17 (a) & (b)] into the duodenum through the **ampulla of Vater**. Sometimes, an accessory pancreatic duct, **duct of Santorini** [Fig. 15.17 (b)] is also present, which directly pours the pancreatic juice. The juice is alkaline (pH = 7.8) due to the presence of sodium bicarbonate. The endocrine part of the pancreas consists of spherical balls of cells called **Islets of Langerhans** scattered in the pancreatic tissue.

Pancreatic juice contains sodium bicarbonate and three pro-enzymes (inactive enzymes): **trypsinogen**, **chymotrypsinogen** and **procarboxypeptidase**. An intestinal activator enzyme, **enterokinase**, activates trypsinogen into trypsin. Activated trypsin then activates chymotrypsinogen and procarboxypeptidase into their respective active forms. Besides, the pancreatic juice also contains **elastase**, **nucleases (ribonuclease, deoxyribonuclease)**, **pancreatic  $\alpha$ -amylase**, **pancreatic lipase or steapsin**, **cholesteryl ester hydrolase** and

**phospholipase.** The pancreatic juice helps in the digestion of starch, proteins, lipids and nucleic acids.

**Functions of Pancreatic Juice**

1. It is alkaline in nature and hence, neutralizes the acidic chyme in the duodenum and makes the food alkaline (pH 8.4)
2. Pancreatic  $\alpha$ -amylase acts on starch and converts it into maltose, maltotriose and limit dextrin.
3. Trypsinogen is activated into trypsin by **enterokinase**, present in the intestinal juice. Trypsin acts on proteins and converts them into peptones (polypeptides of variable length).
4. Chymotrypsin coagulates milk.
5. Elastase acts on elastic fibers of connective tissue.
6. Carboxypeptidase removes amino acids from the C (carboxyl)-terminus of polypeptides.
7. Pancreatic lipase or steapsin completes fat digestion.
8. Pancreatic nucleases hydrolyze nucleic acids into their constituent nucleotides.

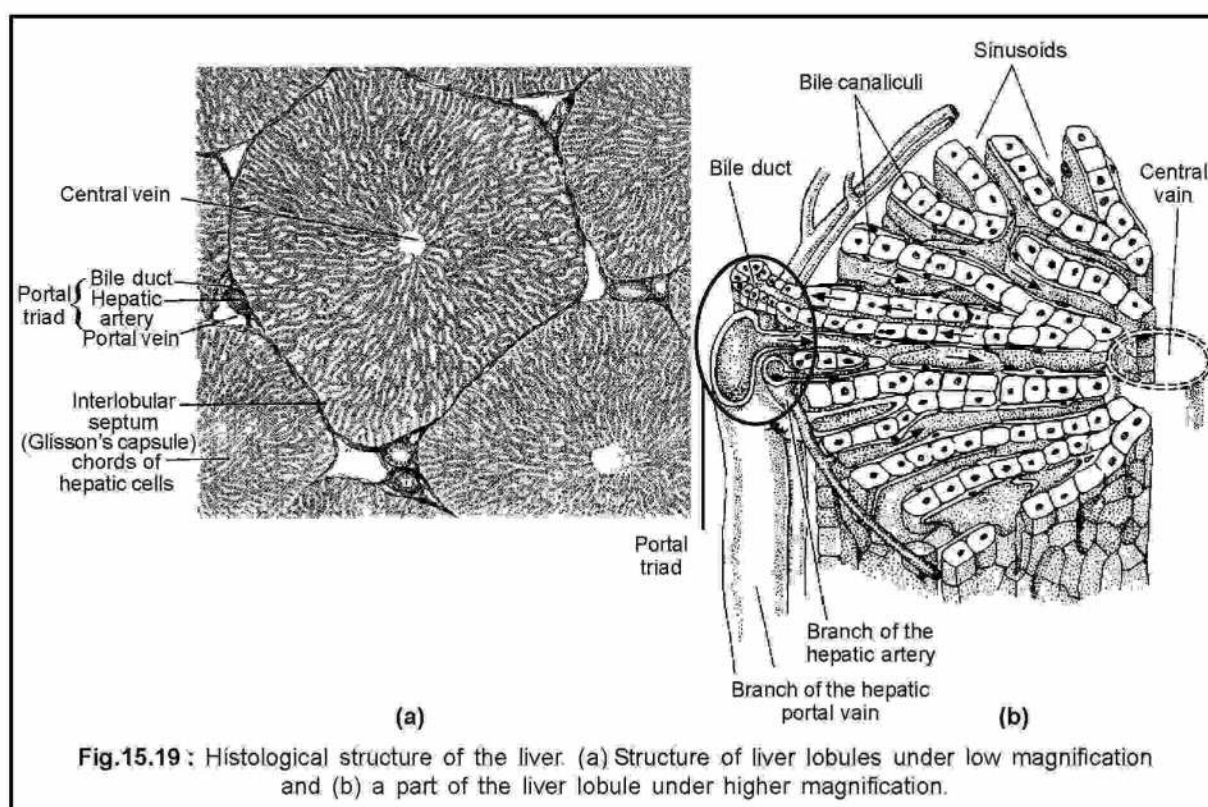

**Fig.15.19 :** Histological structure of the liver. (a) Structure of liver lobules under low magnification and (b) a part of the liver lobule under higher magnification.

**15.3.3.5. Liver :** The liver is the largest gland of the body. It is found in the upper right side of the abdominal cavity and is fitted against the lower face of the diaphragm. It is reddish brown in colour. It is larger in males than in females and weighs about 1.6 kg. The liver is divided into two lobes: a large **right lobe** and a small **left lobe**.

The right lobe consists of **right lobe proper**, **quadrate lobe** and **caudate lobe** (Fig.15.18). A thin-walled, pear-shaped sac, known as **gall bladder** is present on the lower surface of the right lobe. It stores bile, secreted by the liver. The right and left hepatic ducts from the corresponding liver lobes join to form a **common hepatic duct**. The latter joins with the cystic duct of the gall bladder to form a **common bile duct**. The common bile duct passes downward to join the pancreatic duct forming a **hepato-pancreatic ampulla** or **ampulla of Vater**. The ampulla opens into the duodenum. The opening is guarded by **sphincter of Oddi**. Another sphincter muscle or **muscle of Boyden** surrounds the opening of the common bile duct before it joins with the pancreatic duct. This muscle constricts the bile duct, when there is no food in the duodenum.

Histologically, each liver lobe is made up of a number of polygonal columns of hepatic cells, called **hepatic lobules** [Fig.15.19 (a)]. These are the structural and functional units of liver. Each lobule is separated from its adjacent ones by thin inter-lobular septa of connective tissue. Thus, a lobule has a complete connective tissue sheath called **Glisson's capsule** [Fig.15.19 (a)]. In addition to hepatic cells, the liver has Kupffer cells, which destroy bacteria and other germs by phagocytosis.

#### (a) Bile

Bile is a greenish-yellow, alkaline fluid secreted by the liver and stored in a pear-shaped thin walled bladder, called **gall bladder**, present on the lower surface of the right lobe of the liver. The hepatic bile has a the pH of 8.6 whereas pH of gall bladder bile is 7.6.

#### (b) Composition of bile

<b>1. Water</b>	<b>: 97%</b>	<b>Total Solids</b>	<b>: 3%</b>
<b>(i) Inorganic constituents</b>	<b>: 0.7%</b>	Chlorides and phosphates of Sodium, Potassium and bicarbonates of Sodium and Calcium.	
<b>(ii) Organic constituents</b>	<b>: 2.3%</b>		
<b>Bile salts</b>	<b>: 0.7%</b>	(Sodium glycocholate and Sodium taurocholate)	
<b>Bile pigments</b>	<b>: 0.2%</b>	(Bilirubin and Biliverdin)	
<b>Other organic constituents</b>	<b>: 1.4%</b>	(Mucin, cholesterol, lecithin, fat, fatty acids and alkaline phosphatase).	



The bile pigment bilirubin is yellow in colour, while biliverdin is green. Accumulation of bilirubin in body fluids causes a disease, called jaundice, in which skin becomes yellow.

### (c) Functions of bile

1. Bile is alkaline, hence, neutralizes the acidic chyme of the stomach and makes an optimum environment for the action of enzymes in the small intestine.
2. It prevents the food from bacterial contamination, as it kills germs.
3. Bile reduces the surface tension causing the fat to change into an **emulsion**. Bile salts break the larger fat droplets into smaller ones. This process is called **emulsification**. This increases lipase action on fat.
4. Bile facilitates the absorption of fat, fat soluble vitamins (A, D, E, K), iron, calcium etc.
5. Bile excretes heavy metals like copper; zinc; mercury; toxins; bacteria; bile pigments; cholesterol and lecithin.
6. It stimulates peristaltic movement.

### (d) Functions of liver

1. The liver secretes bile.
2. It converts excess glucose into glycogen by **glycogenesis**, with the action of insulin hormone.
3. It converts glycogen into glucose by **glycogenolysis**, as and when necessary, regulated by glucagon hormone.
4. It detoxifies toxic substances.
5. Destroys bacteria by phagocytosis with the help of Kupffer cells.
6. It synthesizes **fibrinogen** and **prothrombin** which help in blood clotting or coagulation.
7. It forms the anticoagulant, called **heparin**.
8. The haemoglobin degrades into bile pigment in the liver.
9. **Deamination** of amino acids takes place in the liver cells.
10. The liver manufactures RBCs in embryos.
11. It synthesizes and stores vitamin B<sub>12</sub>.
12. It stores iron and copper.
13. The liver is the site of formation of glucose and then glycogen from non-carbohydrate sources like proteins and lipids. This process is called **gluconeogenesis**.

14. Conversion of excess glucose and amino acids into fat takes place in the liver. This process is called **lipogenesis**.
15. Liver produces **angiotensinogen** which helps kidneys in maintaining body fluid homeostasis by osmoregulation.
16. Due to high metabolic activity of liver, heat is produced which is necessary for maintaining an optimum body temperature.

#### 15.4. PHYSIOLOGY OF DIGESTION :

Digestion is a combination of mechanical or physical and chemical processes, in which complex macromolecular food is converted into simpler, smaller and easily diffusible products in the alimentary canal, which is absorbed into the body fluid (blood and lymph) for assimilation by the tissues.

The food is digested in a stepwise manner as it passes through different parts of the alimentary canal in a forward direction. Apart from digestion, the alimentary canal conducts, stores and absorbs the digested food. Thus, there is a physiological division of labour and on the basis of this, the alimentary canal is divided into four zones.

**(a) Ingressive zone :** It ingests and masticates the food. It includes mouth, buccal cavity, tongue and teeth.

**(b) Progressive zone :** It conducts, stores and partly, digests food, and includes pharynx, oesophagus and stomach.

**(c) Digressive zone :** It completes the digestion and absorption of the food. It includes small intestine.

**(d) Egressive zone :** It temporarily stores and finally eliminates the faecal matter to the exterior. It includes colon, rectum, anal canal and anus.

##### 15.4.1. Digestion in the Buccal Cavity :

The digestion of food begins in the buccal cavity, where it is ground into finer particles; and moistened and masticated with saliva to form a soft and pulpy mass, called **bolus**. Food remains in the buccal cavity for about 14 to 18 seconds and then it is swallowed. The presence of food in the buccal cavity acts as a stimulus for the secretion of saliva from the salivary glands and swallowing.

##### **(a) Mastication**

Mastication or the act of chewing refers to a combined mechanical action of the salivary glands, teeth, tongue and cheek muscle. This leads to the secretion and mixing of the saliva with the food, which converts it into bolus. The saliva contains mucous and a carbohydrate digesting enzyme,  **$\alpha$ -amylase** or **ptyalin** and **lingual lipase**. Lingual lipase is a lipolytic enzyme. However, it does not work in the buccal cavity and starts working with gastric lipase only in the stomach. Salivary  $\alpha$ -amylase acts on starch and hydrolyzes the  **$\alpha$  (1-4) glycosidic bonds**. Consequently, starch converts into **maltose**; and **maltotriose** both

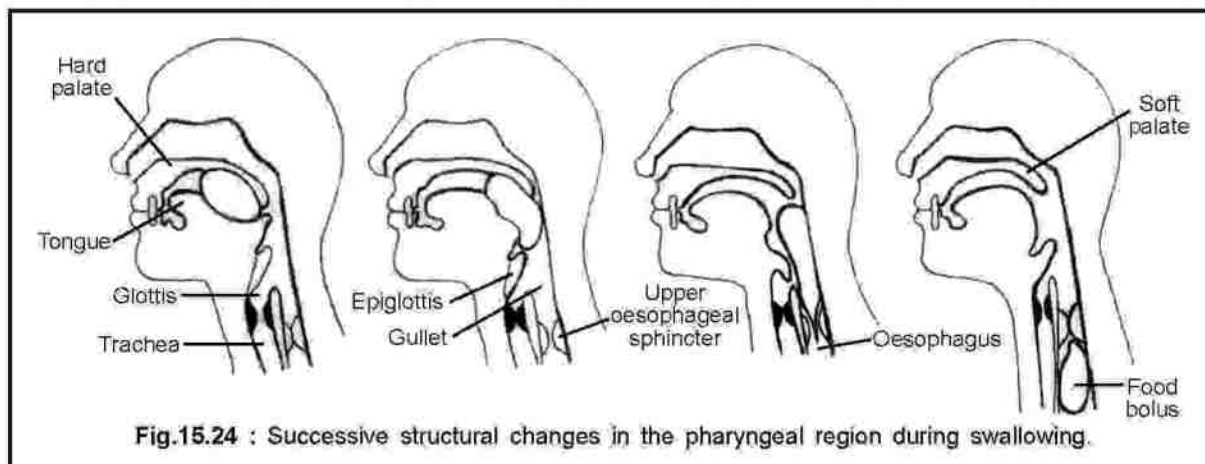

with  $\alpha$ -1, 4 glycosidic bonds and a branched macromolecule called **limit dextrin** or  **$\alpha$ -dextrin**, containing, on an average, eight molecules of glucose. Salivary amylase acts best in the presence of the activator, chloride ions at pH 6.7.

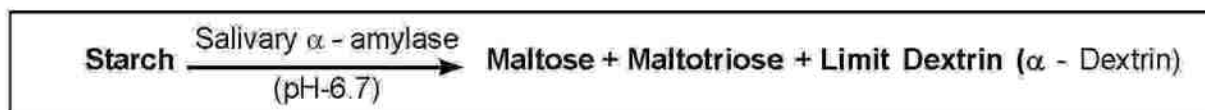

**(b) Deglutition (Swallowing)**

**Deglutition** or the **act of swallowing** is a process by which the bolus is transferred from the mouth to the stomach through the oesophagus (Fig.15.20). This process is a complicated muscular reflex, involving a series of coordinated muscular movements of the mouth; tongue; pharynx; and oesophagus.

The bolus passes down the oesophagus by a series of **peristaltic contraction** of the muscles in the oesophageal wall. This is assisted by the secretion of mucous from the mucosa of the oesophagus. The food does not undergo any chemical modification in the oesophagus.

**15.4.2. Digestion in the Stomach :**

The bolus remains inside the stomach for several hours and following its digestion, it passes into the intestine in slow spurts. The stomach plays three important roles: (1) it acts as a temporary reservoir of the partially digested food received from the oesophagus; (2) it acts as a mechanical mixer; and (3) it is the site of active **protein digestion**. **A little amount of fat is also digested in the stomach**. There is practically no carbohydrate digestion in the stomach, but the HCl can carry out the hydrolysis of sucrose into glucose and fructose to some extent.

**(a) Mechanical Events :** Due to the periodic muscular contractions and relaxations in the wall of the stomach, the bolus is thoroughly **churned** (Fig.15.21). The cardiac and pyloric sphincters remain closed during churning of the food. Then it is mixed with the gastric juice and the digestion of proteins commences.

**(b) Biochemical Events :** As soon as the food bolus reaches the stomach, the enteroendocrine cells of the antral mucosa secrete a hormone called **gastrin**. It stimulates the gastric glands to produce **gastric juice**. The gastric juice consists of **mucus**; **hydrochloric acid (HCl)**; pro-enzymes, **pepsinogen** and **pro-rennin**; and **gastric lipase**.

**(c) Role of HCl in digestion**

- (i) It provides an optimum pH for pepsin activity.
- (ii) It activates inactive pepsinogen and prorennin into active pepsin and rennin, respectively.
- (iii) It inhibits the action of ptyalin.
- (iv) It acts as an antibacterial agent.
- (v) It causes denaturation and swelling of proteins, so that enzymes can act well on them.
- (vi) It regulates the opening and closing of the pyloric sphincter.
- (vii) It softens the food for enzyme action.

**(d) Action of Pepsin :** Inactive pepsinogen is first activated into active pepsin under the influence of HCl (Fig.15.22). Then the activated pepsin itself activates pepsinogen into pepsin. Such activation is known as **autocatalytic activation**. Pepsin is an **endopeptidase**, which digests proteins into **polypeptides of variable lengths** or **peptones** in an acidic medium. No free amino acid is released by pepsin digestion. The maximum activity of pepsin is exerted at two pH ranges, 1.6 to 2.4 and 3.4 to 3.9.

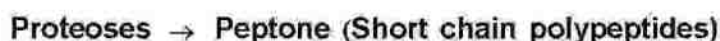
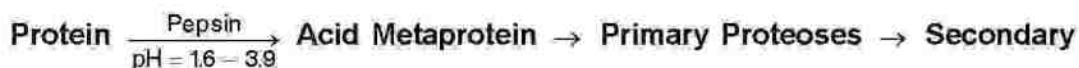

**(e) Action of Rennin :** Prorennin is a proenzyme that is inactive. It is activated by HCl into an active **rennin** or **chymosin**. Rennin hydrolyses the milk protein, **casein** into **para-casein** and **whey protein** (peptone-like substance). Para-casein is transformed into

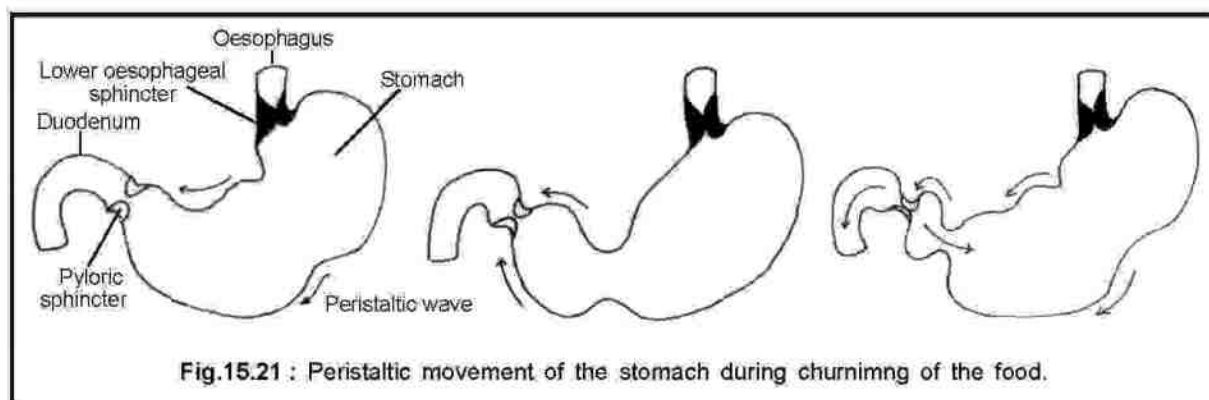

**Fig.15.21 :** Peristaltic movement of the stomach during churning of the food.

insoluble calcium para-caseinate in the presence of calcium ions. This is known as clotting or curdling of milk. The curd is acted upon by pepsin and forms peptone. The curd stays in the stomach for a relatively longer period for proper digestion by pepsin. Rennin is absent in adult human gastric juice. The clotting and digestion of milk in adult human stomach mainly takes place by means of HCl and pepsin, respectively.



**(f) Action of Gastric Lipase :** Gastric lipase is a weak lipolytic (lipid digesting) enzyme. It hydrolyzes fat into glycerol and fatty acids. Fat digestion in the stomach is not significant. Its complete digestion is carried out in the duodenum by pancreatic lipase.

The thick acidic mixture of gastric juice and partially digested food form a thick acidic paste, called chyme in the stomach. Gastric digestion takes about 3 to 5 hours. However, it depends upon the nature of food ingested. The chyme passes into the duodenum at intervals by the peristaltic contractions of the stomach. The pyloric sphincter of the stomach opens to release the chyme in spurts.

**15.4.3. Digestion in Small Intestine :**

In the small intestine, the chyme undergoes further mechanical and chemical processing. The mechanical processing involves the segmented contraction of the wall of the intestine, which mixes the chyme with digestive juice and liquefies it still further (Fig.15.23). This act accelerates the subsequent chemical treatment by the enzymes. Digestion in the small intestine has been described in two parts : (a) digestion in the duodenum; and (b) digestion in the jejunum and ileum (enteric digestion).

**(a) Digestion in the Duodenum**

In the duodenum, the chyme is mixed with three alkaline juices; bile from the liver, pancreatic juice from the pancreas, and intestinal juice from intestinal glands (crypts of Lieberkuhn); and mucous from the Brunner's glands.

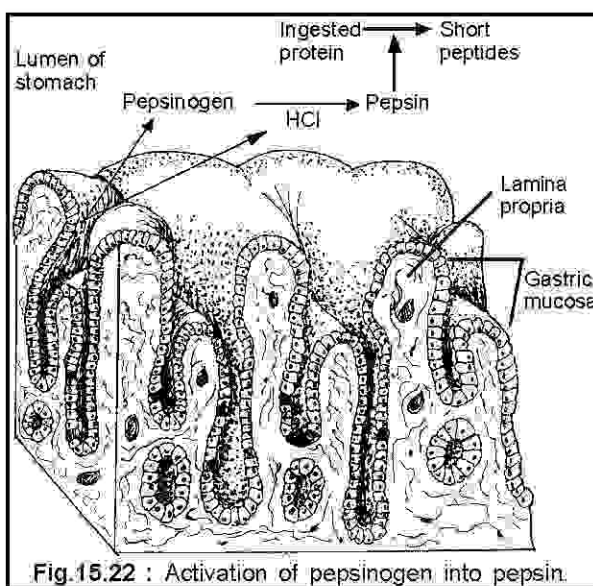

Fig.15.22 : Activation of pepsinogen into pepsin.

The enteroendocrine cells present in the mucosal layer of the duodenum are stimulated to secrete several gastro-intestinal hormones, when the acidified chyme of the stomach enters into it. Two such hormones bearing significant roles in the release of digestive juices are: **Cholecystokinin-Pancreozymin (CCK-PZ)** and **Secretin**.

**(i) Cholecystokinin-Pancreozymin (CCK-PZ) :**

It is a single hormone possessing two activities. Cholecystokinin (CCK) activity stimulates the gall bladder to contract and release bile into the duodenum, while pancreozymin activity stimulates the acinar cells of the pancreas to secrete increasing amounts of pancreatic juice, rich in enzymes.

**(ii) Secretin :** It stimulates the duct cells of the pancreatic acini to secrete sodium bicarbonate into the pancreatic juice and thus makes the pancreatic juice alkaline.

In addition, **enterogastrone** is presumed to be a separate hormone regulating gastro-intestinal functions. However, it is not a separate entity, but rather a collection of two hormones, secretin and cholecystokinin-pancreozymin, which inhibit gastric function.

**(b) Action of Pancreatic Juice**

**(i) Digestion of Proteins**

All proteases (proteolytic enzymes) of the pancreatic and intestinal juices fall under two broad categories : **endopeptidases** and **exopeptidases**. An endopeptidase hydrolyzes internal peptide bonds, while an exopeptidase hydrolyzes peptide bonds from C- or N- ends in a sequence. Accordingly, exopeptidases are **carboxypeptidases** and **aminopeptidases**, respectively.

**Trypsin :** Inactive proenzyme trypsinogen is activated to trypsin by an enteropeptidase, known as enterokinase, present in the intestinal juice. Trypsin is an **endopeptidase** that converts proteins and polypeptides into peptones (peptides of variable lengths).

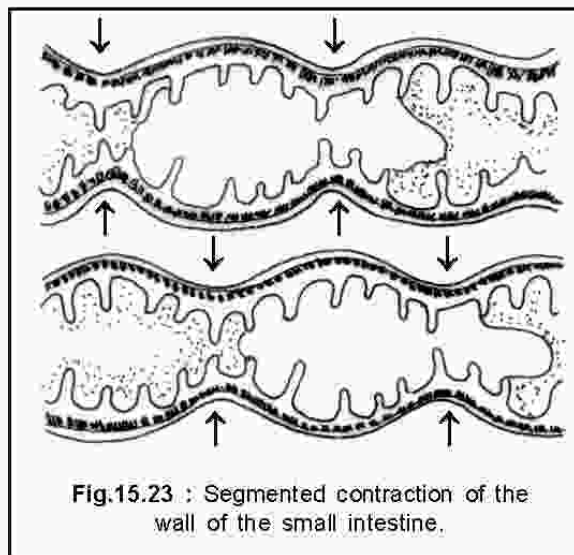
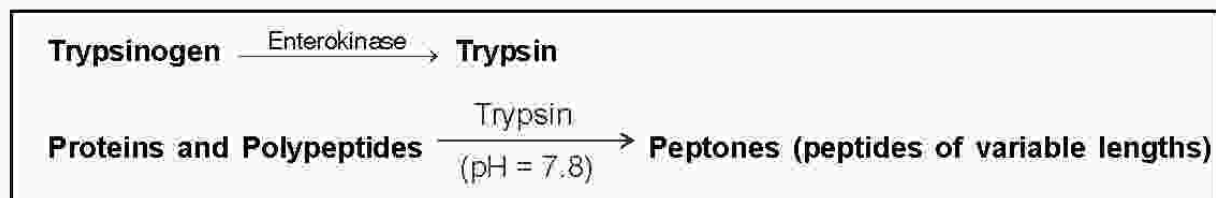
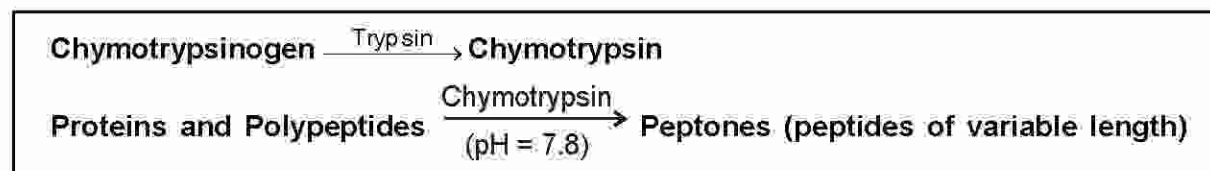

Fig.15.23 : Segmented contraction of the wall of the small intestine.

**Chymotrypsin** : Once trypsin becomes active, it activates proenzyme **chymotrypsinogen** to **chymotrypsin**. It is also an **endopeptidase** that converts proteins and polypeptides into peptones.



**Elastase** : Proelastase is activated into elastase by trypsin. It is an **endopeptidase**, which acts on elastin and converts it into peptides of variable lengths.

**Carboxypeptidase** : Proenzyme procarboxypeptidase is activated to carboxypeptidase by trypsin. It is an **exopeptidase**, which converts peptides into dipeptides and amino acids by removing amino acids from the C-terminus of peptides.

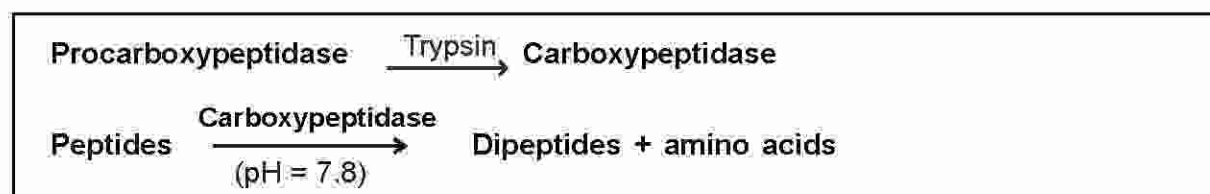

**Pancreatic nucleases** : Pancreatic juice also contains nucleases (**ribonuclease** and **deoxyribonuclease**), which hydrolyze RNA and DNA, into their respective constituent nucleotides.

### (ii) Digestion of carbohydrates

Pancreatic juice contains a carbohydrate digesting enzyme, called **pancreatic  $\alpha$ -amylase**. This enzyme hydrolyzes starch, in a similar manner to salivary  $\alpha$ -amylase. Starch is converted to a mixture of disaccharides and trisaccharides and limit dextrin in an alkaline medium.



### (iii) Digestion of Fat

Pancreatic juice contains pancreatic lipase (**steapsin**), which is the principal fat digesting enzyme. It digests about two third of the fat in stages.

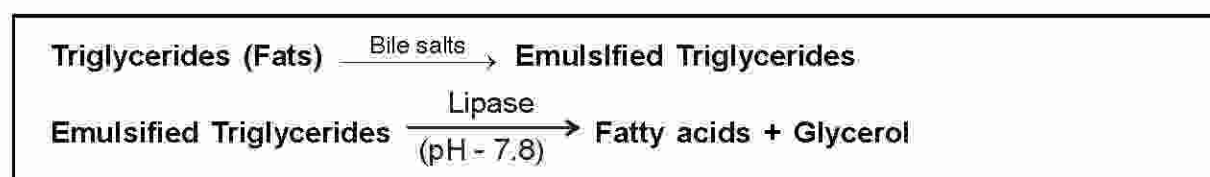

**(b) Digestion in the Ileum**

The ileum has simple tubular glands invaginated into the lamina propria of the mucosa. These glands are known as **crypts of Lieberkuhn**, which secrete **intestinal juice** or **succus entericus**. It contains: carbohydrate digesting enzymes; two proteases; an activator, enterokinase; intestinal lipase; and three nucleolytic enzymes, such as nucleotidase, nucleosidase and phosphatase.

**(i) Digestion of carbohydrates**

The intestinal juice contains a numbers of oligosaccharidases which hydrolyze oligosaccharides into their constituent monosaccharides.

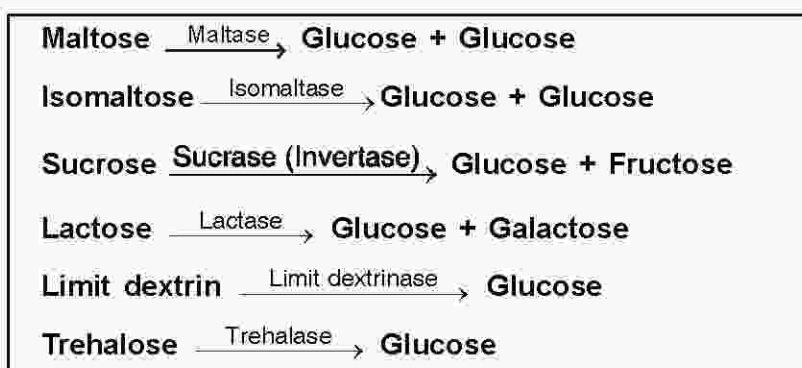

A major part of the hydrolysis occurs in the lumen of the small intestine. However, a small part of it occurs in the outer part of the brush border of the microvilli membrane.

Deficiency of one or more brush border enzymes may cause diarrhoea and flatulence following the ingestion of sugar. Absence of lactase from the intestinal juice leads to a serious disorder, called **lactose intolerance**. In such a case, the lactose can not be digested, which accumulates in the intestine and causes vomiting.

**(ii) Digestion of proteins****Non digestive protease**

(i) **Enteropeptidase (Enterokinase)** : It is an activating enzyme. It activates the proenzyme, trypsinogen into trypsin.

**Digestive proteases**

(i) **Aminopeptidase (Erepsin)** : It hydrolyzes the terminal peptide bonds at the N-terminus of the peptide to release amino acids one by one.



(i) **Dipeptidase** : It hydrolyzes the dipeptides into constituent amino acids.





**(iii) Digestion of fat**

The intestinal lipase hydrolyzes some triglycerides, diglycerides and monoglycerides to fatty acids and glycerol.

**(iv) Digestion of nucleic acids**

The nucleic acids are digested in the ileum by the action of three nucleolytic enzymes:

**Nucleases** : These hydrolyze nucleic acids into nucleotides. These are of two types: deoxyribonuclease and ribonuclease. Deoxyribonuclease acts on DNA, while ribonuclease on RNA.

**Phosphatase** : It hydrolyzes a nucleotide into a nucleoside and phosphoric acid.

**Nucleosidase** : It hydrolyzes nucleosides into free nitrogenous bases and pentose sugar.

The fully digested and alkaline food present in the small intestine is called **chyle**. The chyle is then passed into the large intestine by peristalsis.

**15.4.4. Digestion in the large intestine :**

There is practically no digestion in the large intestine or colon. The food entering into the colon is almost completely digested and absorbed in the small intestine with the exception of cellulose present in the vegetable matter. **Bacterial fermentation** in the large intestine breaks down cellulose tissue into vegetable cells which are then digested by enteric enzymes and partly absorbed. The microbial flora or bacteria of the colon convert (i) carbohydrate residue into organic acid and methane; (ii) lipids into fatty acids and glycerol and (iii) proteins into amino acids by decarboxylation. Some vitamins like vitamin K and vitamin B-complex are also produced in the large intestine.

**15.5. ABSORPTION OF FOOD :**

Absorption is the passage of end products of digestion, such as monosaccharides; amino acids; fatty acids and glycerol as well as minerals; vitamins; and water from the digestive tract into the blood and lymph through the intestinal epithelium.

No absorption takes place in the buccal cavity. In the stomach, the absorption is limited. Some mineral salts, alcohol, glucose, water and some easily diffusible drugs are absorbed directly at a very low rate. A comparatively smaller amount of these substances is absorbed in the duodenum. Practically all absorption takes place through the ileum, where the absorptive surface area is highly increased owing to the presence of around 5,000,000 villi. The villi are small (0.5 mm long) finger-like projections of the mucosal epithelium (Fig.15.24). Each villus contains capillary plexus and lymph vessels called **lacteals**. The surface area of the epithelial cells of the villus is increased due to the presence of many ultramicroscopic evaginations or cylindrical projections of the plasma membrane, called **microvilli**. The microvilli form a **brush border**.

### 15.5.1. Absorption of monosaccharides :

The end products of carbohydrate digestion, monosaccharides, such as glucose, fructose, galactose, etc. are rapidly absorbed into the blood stream across the wall of the small intestine. This absorption or transport is dependent on the concentration of  $\text{Na}^+$  in the intestinal lumen. A high  $\text{Na}^+$  concentration in the lumen facilitates the transport of glucose into the epithelial cells. Both glucose and  $\text{Na}^+$  are transported into the cells by a **membrane transporter** (a transporter is a membrane

integral protein), called **cotransporter** or more specifically, **sodium dependent glucose transporter (SGLT)**. Following the transport into the epithelial cells,  $\text{Na}^+$  is released back into the intestinal lumen, while glucose is released into the cytosol. Thus, glucose absorption is a **secondary active transport**. The energy for glucose transport is provided by the active transport of  $\text{Na}^+$  out of the cell. The monosaccharides absorbed into the cytosol and then into the interstitium, enter into the hepatic portal circulation.

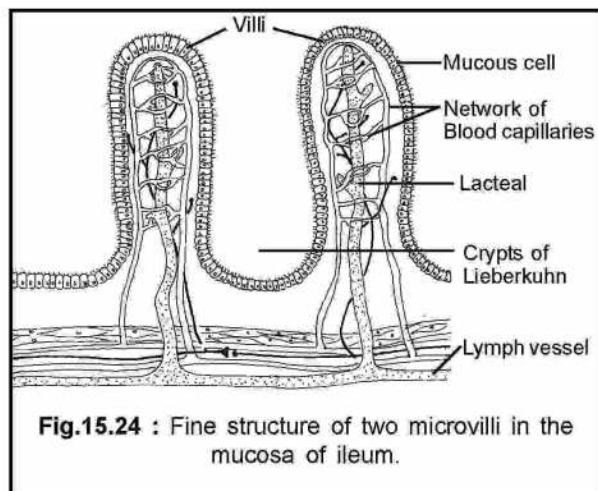

**Fig.15.24** : Fine structure of two microvilli in the mucosa of ileum.

### 15.5.2. Absorption of amino acids :

Amino acids are directly absorbed into the intestinal epithelial cells and then released into the interstitium by simple diffusion. Larger peptides are never absorbed. However, di- and tripeptides are absorbed into the epithelial cells by **cotransport**. This transport is dependent on  $\text{H}^+$ , rather than  $\text{Na}^+$ . Like the monosaccharides, the amino acids enter into the hepatic portal circulation.

### 15.5.3. Absorption of fatty acids and glycerol :

Fatty acids combine with the bile salts forming small molecular aggregates, called **micelles**. These are absorbed into the cells, through the mediation of carriers. Short chain fatty acids (10-12 carbon atoms) pass directly into **lymph vessels (lacteals)**, while those with more carbon atoms are re-esterified in the mucosal cells. Absorbed cholesterol is also esterified into cholesteryl esters. All these esterified products are coated with proteins forming **chylomicrons**. These are then absorbed directly into the lymph vessels. The chylomicrons are absorbed into the hepatic portal circulation through the lacteal.

### 15.5.4. Absorption of water and electrolytes :

A healthy adult human drinks about 2000 ml of water and 7000 ml of secretions are poured into the alimentary canal in 24 hrs; 98% of this sum total fluid is reabsorbed with a loss of only 200 ml in the stool. As discussed above  $\text{Na}^+$  absorption is linked to the presence

of glucose in the intestine. It is absorbed by a secondary active transport mechanism. This forms the basis for the oral rehydration of NaCl with glucose in diarrhoea patients.  $2\text{Cl}^-$  are cotransported with one each of  $\text{Na}^+$  and  $\text{K}^+$ .  $\text{Na}^+$  and  $\text{K}^+$  are driven into the cells by active transport mediated by  $\text{Na}^+ - \text{K}^+$  ATPase of the membrane.

#### 15.5.5. Absorption of vitamins :

Absorption of water soluble vitamins is rapid, while that of the fat soluble ones is depressed, if the pancreatic juice and bile secretions are inadequate. Most of the vitamins are absorbed in the jejunum, while  $\text{B}_{12}$  is absorbed in the ileum.

#### 15.5.6. Absorption of minerals :

These are absorbed mostly in the small intestine. 30-80% of calcium is absorbed in the upper small intestine by active transport. Active transport of calcium is induced by a metabolite of vitamin D that is produced in the kidneys. Iron is another important mineral absorbed in the small intestine. The amount of iron absorbed, replenishes the amount lost due to various reasons. For the active absorption of sodium in intestine a sodium pump mechanism works in the cell membrane.

### 15.6. ASSIMILATION :

The required amount of absorbed food materials is transported from the blood to the cells and tissues of different parts of the body. This is known as assimilation. A part of the food materials undergoes biological oxidation to meet the energy requirement during work. Another part is used for building the extra organic matter during growth and repair of the body. Any excess of the food is stored as reserve food to be used during exigency.

#### 15.6.1. Fate of Amino Acid :

Amino acids are not stored in the body. They are either metabolized through **transamination** and **oxidative deamination** or used in protein synthesis. Proteins are used for growth and repair of tissues or act as enzymes and hormones or act as antibodies, the defense molecules of the body. Some amino acids are converted to glucose by **gluconeogenesis** during exigency.

#### 15.6.2. Fate of Monosaccharides :

Monosaccharides constitute a ready source of energy for the cells and tissues. Any excess is stored in the liver and muscle cells as **glycogen**. The synthesis of glycogen from these substrates in the presence of insulin, is known as **glycogenesis**. Major part of the absorbed glucose acts as respiratory fuel and is utilised in the production of energy for various body activities. Some are converted into amino acids and fat.

### 15.6.3. Fate of lipids :

Lipids are used in the formation of biological membranes and insulation sheaths of **medullated** or **myelinated nerve fibers**. Excess fat is stored in the **adipose tissue**. Stored fat also serve as respiratory fuel for the cell.

### 15.6.4. Calorific value of food :

The amount of energy released from the food substrates in cellular oxidation is termed as their calorific value, which is expressed in calories (cal) or kilocalories (kcal). The value for one gram of carbohydrate is 4.1 kcal, for one gram of protein is 4.1 kcal and for one gram of lipid is 9.3 kcal. It is essential to know the calorific value of the food stuffs we consume to work out the ration, as the energy expenditures of persons of different ages, sexes and occupations vary. For a man of 80 Kg. body weight, maximum calorie intake is :  $80 \times 24 = 1920$  cal, and the prescribed reduction is :  $1920 - 500 = 1420$  cal. However, daily intake should never go below 1000 cal. We get about 50% of our energy from carbohydrates, 15% from proteins and 35% from fats.

### 15.7. EGESTION :

The elimination of undigested residual food is called **egestion** or **defaecation**. The waste material discharged from the alimentary canal is called faeces or faecal matter. Following the absorption of essential food materials; water; minerals; and vitamins, the residue turns into a yellow coloured semisolid, called stool. The yellow colour of the stool is due to the excretion of bile pigments, especially billirubin into it. Methanogenic bacteria act upon the residue to generate methane that gives the stool a characteristic foul smell. It is finally eliminated through the anal aperture or anus. Summary of the physiology of digestion in human is depicted in Fig.15.25 and Table-15.1.

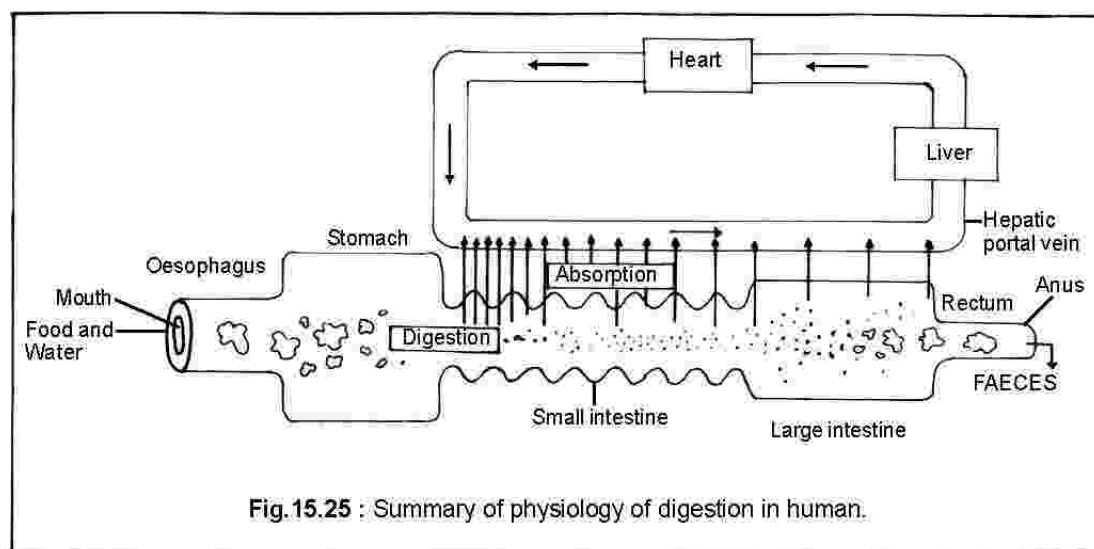

Fig.15.25 : Summary of physiology of digestion in human.

**TABLE-15.1 : SUMMARY OF DIGESTIVE ENZYMES AND THEIR ACTIONS**

Enzymes	Source	Substrate	Products
$\alpha$ -Amylase	Saliva and Pancreatic juice	Starch, glycogen	Disaccharides, Trisaccharides and $\alpha$ -Dextrin
Pepsinogen	Gastric juice	Pepsinogen (inactive)	Pepsin (activated by HCl)
Pepsin	Gastric juice	Proteins	Peptones (Short chain polypeptides)
Rennin	Gastric juice	Milk protein (Casein)	Paracasein and Calcium para caseinate
Trypsinogen	Pancreatic juice	Trypsinogen (inactive)	Trypsin (activated by enterokinase)
Trypsin	Pancreatic juice	Proteins	Peptones (short chain polypeptides)
Chymotrypsinogen	Pancreatic juice	Chymotrypsinogen (inactive)	Chymotrypsin (activated by trypsin)
Chymotrypsin	Pancreatic juice	Proteins	Polypeptides of variable lengths
Procarboxypeptidase	Pancreatic juice	Procarboxypeptidase (inactive)	Carboxypeptidase (activated by trypsin)
Carboxypeptidase	Pancreatic juice	Polypeptides	Dipeptides and amino acids
Lipase	Pancreatic juice	Triglycerides (Neutral fat)	Fattyacids and glycerol
Nuclease	Pancreatic juice	Nucleic acids	Nucleotides
Enterokinase	Intestinal juice	Trypsinogen (Inactive)	Trypsin (active)
Aminopeptidase	Intestinal juice	Polypeptides	Amino acids
Dipeptidase	Intestinal juice	Dipeptides	Aminoacids
Maltase, Sucrase and Lactase	Intestinal juice	Maltose, sucrose and lactose, respectively	Monosacchrides
Limit dextrinase	Intestinal juice	Limit dextrin	Glucose

**TABLE-15.2 : SUMMARY OF FUNCTIONS OF GASTRO-INTESTINAL HORMONES**

Sl. No.	Hormone	Secreted from	Stimulated by	Inhibited by	Functions
1.	Gastrin	Gastric mucosa of the pyloric antrum	Presence of amino acids and peptides in the stomach	HCl in the stomach	Stimulates HCl and pepsinogen secretion from the oxyntic (parietal) and chief (peptic) cells, respectively.
2.	Cholecystokinin-Pancreozymin (CCK-PZ)	Mucosa of the duodenum	Presence of acidic chyme containing, amino acids and fatty acids in the duodenum	Empty duodenum	1. CCK stimulates the contraction of the gall bladder to release bile into the duodenum. 2. PZ stimulates the pancreas to release pancreatic juice containing enzymes.
3.	Secretin	Mucosa of the duodenum	Acidic chyme in the duodenum	Empty duodenum	Stimulates the pancreatic acinar duct cells to secrete bicarbonates into the pancreatic juice

## 15.8. NUTRITIONAL AND DIGESTIVE DISORDERS :

Every organism requires an adequate quantity of food (nutrients) in proper proportion for meeting the energy requirement and growth and development requirements.

### 15.8.1. Malnutrition :

Malnutrition is the intake of less than normal quantity of food, required by body. It is primarily due to inadequate intake of food both in quantity and quality. The nutritional deficiency, particularly of proteins of less calorific value for a long period of time causes many deficiency diseases. It is also known as **Protein energy malnutrition (PEM)**. It mostly affects infants and children of the developing countries. Two commonly occurring diseases due to PEM are (i) Kwashiorkor and (ii) Marasmus.

### 15.8.2. Kwashiorkor :

This disease is caused in children in the age group of 6 months to 3 years. It is caused by severe protein deficiency.

#### (a) Symptoms

1. Stunted growth and bulging of the belly and eyes.
2. Loss of appetite and anaemia.
3. Decreased immunity.
4. Darkening of skin and hair.
5. Recurrence of diarrhoea.
6. Atrophy of muscle and oedema in the hands, feet and face.

#### (b) Control

The disease is controlled by providing high quality protein in the diet.

### 15.8.3. Marasmus disease :

It is a type of disease, in which there is deficiency of proteins and calories. It is more common in infants under one year of age.

#### (a) Causes

It is caused by prolonged deficiency of proteins and or carbohydrates.

#### (b) Symptoms

1. Dry and wrinkled skin.
2. Stunted growth of the body with extreme thinning of the limbs.
3. Ribs protrude as the fat layer of the skin disappears.
4. Retarded Physical and mental growth.
5. Recurrence of diarrhoea.

#### (c) Control

It is controlled when the affected infant is given adequate proteins, fats and carbohydrates in the diet.

**15.8.4. Indigestion (Dyspepsia) :**

This is a condition in which food is not properly digested. The person gets a feeling of fullness during meal, thus not being able to finish eating. A burning sensation occurs in the stomach and oesophagus due to excessive gas formation. The causes of indigestion include insufficient enzyme secretion, food poisoning, over eating, eating of spicy or fatty food, anxiety, cancer, ulcer, etc.

**15.8.5. Constipation :**

In this disorder, the faeces in the rectum are not removed properly as bowel movements become difficult, irregular or happen less than normal. This results in hardening of the stool. The abdomen swells accompanied by abdominal pain. Constipation occurs due to frequent changes in the food habit, least consumption of fiber-rich food and drinking less water than required.

**15.8.6. Vomiting**

It is the forcible emptying of the stomach contents through the mouth. This takes place due to violent contraction of the stomach. The causes of vomiting are varied and include food allergies, infections of the stomach and food poisoning. A feeling of nausea occurs before vomiting. The vomiting centre present in the medulla of the brain regulates vomiting through neural communication.

**15.8.7. Jaundice (Icterus)**

Jaundice or Icterus is a yellowish pigmentation of the skin, conjunctiva (white of the eyeball) and other mucous membrane caused by high blood bilirubin level. These symptoms are expressed in liver diseases, liver cancer and obstruction of the bile duct by gall bladder stone formation. Excess bilirubin is excreted in the urine imparting it an intense yellow colour. In hepatitis (inflammation of the liver) the symptoms of jaundice are often expressed. Jaundice occurs by drinking contaminated water. Medical treatment ranges from supportive care and rest to transfusion of fluid in case of dehydration and oral administration of liver rejuvenating drugs, antibiotics and antiviral drugs as per the advice of a registered medical practitioner.

**15.8.8. Diarrhoea (Loose motion or Looseness of bowel)**

In this disorder the faecal matter is discharged from the bowels frequently in a liquid form. The most common cause of diarrhoea is an infection of the intestine by a virus or bacterium or parasite. This may lead to dehydration due to an excess loss of fluid, decreased urination, loss of skin colour, increased heart rate and reduced responsiveness. Oral Rehydration Solution (ORS) and intravenous transfusion of rehydration solution treatments are essential to restore the fluid and salt loss from the body fluid. Diarrhoea can be prevented by improved sanitation, clean drinking water and hand washing with soap and administration of specific antibiotic drugs.

---

## SAMPLE QUESTIONS

### GROUP - A (Objective-type Questions)

#### 1. Choose the correct answer

- (i) Glucose is stored as glycogen in :  
(a) Pancreas (b) Liver  
(c) Stomach (d) Kidney
- (ii) Ascorbic acid is also known as :  
(a) Vitamin B (b) Vitamin C  
(c) Vitamin E (d) Vitamin D
- (iii) Which gland functions as both exocrine and endocrine glands?  
(a) Salivary gland (b) Gastric gland  
(c) Pancreas (d) Liver
- (iv) Pepsinogen is activated by :  
(a) Trypsin (b) Chymotrypsin  
(c) Hydrochloric acid (d) Pepsin
- (v) Trypsin converts :  
(a) Fats into fatty acids (c) Proteins into peptones  
(b) Polysaccharides into maltose (d) Peptones into amino acids
- (vi) The end products of fat digestion are fatty acids and  
(a) Glycerol (b) Cholesterol  
(c) Phospholipid (d) Glycolipid
- (vii) The posterior free part of the soft palate is known as :  
(a) Glottis (b) Gullet  
(c) Epiglottis (d) Uvula
- (viii) The number of teeth in the deciduous set of human being is :  
(a) 32 (b) 20  
(c) 18 (d) 24
- (ix) The opening of the middle ear into the pharynx is known as  
(a) Eustachian opening (c) External nostril  
(b) Internal nostril (d) Glottis



- (x) The gastro-intestinal hormone that stimulates the contraction of the gall bladder is known as :
- (a) Gastrin (b) Cholecystokinin  
(c) Secretin (d) Motilin
- (xi) The wall of the stomach of human is histologically unique in possessing :
- (a) Submucosa (b) Circular muscle  
(c) Longitudinal muscle (d) Oblique muscle
- (xii) Gastrin is secreted from the mucosa of :
- (a) Antrum (b) Fundus  
(c) Body (d) Pylorus
- (xiii) Brunner's glands are present in the mucosa of :
- (a) Ileum (b) Jejunum  
(c) Duodenum (d) Colon
- (xiv) Secretin stimulates the release of :
- (a) Bicarbonate ions into the pancreatic juice  
(b) Water into the pancreatic juice  
(c) Enzymes into the pancreatic juice  
(d)  $\text{Ca}^{2+}$  into the pancreatic juice
- (xv) Kwashiorkor, a nutritional disorder, caused due to the deficiency of :
- (a) Carbohydrates (b) Lipids  
(c) Vitamins (d) Proteins
- (xvi) In a polypeptide, the amino acids are joined together by :
- (a) Glycosidic bonds (c) Phosphodiester bonds  
(b) Peptide bonds (d) Hydrogen bonds

**2. Answer each of the following in one or more words, wherever necessary.**

- (i) Name the mass of vascular connective tissue in a tooth.
- (ii) Name the water soluble vitamins.
- (iii) Enlist the fat soluble vitamins.
- (iv) Name three divisions of the small intestine.
- (v) Name the vestigial organ in the alimentary canal of human.
- (vi) Which gland is the largest gland of the body ?
- (vii) Name the term used for the presence of different types of teeth.
- (viii) Name two bile pigments.

- (ix) How many liver lobes are there in human ?
- (x) Name the ampulla formed by the joining of the common bile duct and pancreatic duct before opening into the duodenum.
- (xi) Name the phagocytic cell in the liver.
- (xii) What is the non-digestive enzyme released in the small intestine?
- (xiii) Name the enzyme that digests fat.
- (xiv) Name the structure that is formed by the grouping of hepatic artery, hepatic portal vein and bile duct in the liver.
- (xv) Give an alternate name for Ptyalin.
- (xvi) Name the end product of protein digestion.
- (xvii) Name the intestinal glands, which secrete succus entericus.

**3. Fill in the blanks with appropriate words.**

- (i) The fibrous connective tissue that cements the root of the tooth to the socket is known as \_\_\_\_\_.
- (ii) The last molar teeth in human are known as \_\_\_\_\_ teeth.
- (iii) \_\_\_\_\_ is the hardest substance in the human body.
- (iv) The longitudinal folds of the oesophageal mucosa are known as \_\_\_\_\_.
- (v) The passage of the bolus through the lumen of oesophagus in spurts is known as \_\_\_\_\_.
- (vi) The opening of the common bile duct and pancreatic duct into the duodenum is guarded by a sphincter, called \_\_\_\_\_.
- (vii) The gastro-intestinal hormone that stimulates the secretion of enzymes into the pancreatic juice is known as \_\_\_\_\_.
- (viii) The connective tissue sheath, surrounding a liver lobule is known as \_\_\_\_\_.
- (ix) Bile facilitates the digestion of fat by dividing large fat droplets into a number of smaller droplets. This function of bile is known as \_\_\_\_\_.
- (x) Intestinal juice is alternately known as \_\_\_\_\_.
- (xi) There are \_\_\_\_\_ pairs of salivary glands in human.
- (xii) \_\_\_\_\_ is the substrate for ptyalin.
- (xiii) The yellow colour of the stool is due to the presence of a pigment \_\_\_\_\_.
- (xiv) Limit dextrinase or  $\alpha$ -Dextrinase is alternately known as \_\_\_\_\_.
- (xv) Synthesis of glucose from non-carbohydrate sources is known as \_\_\_\_\_.
- (xvi) Rennin acts on the milk protein \_\_\_\_\_ and changes it into \_\_\_\_\_ in the presence of  $\text{Ca}^{2+}$ .

- (xvii) Bile is secreted by \_\_\_\_\_ and stored in \_\_\_\_\_.
- (xviii) The coagulation factors, prothrombin and fibrinogen are synthesized in \_\_\_\_\_.

**4. Match the words of Group A with those of B to make meaningful pairs.**

**Group A**

1. Chief cell
2. Meissner's plexus
3. Trypsinogen
4. Indigestion
5. Islets of Langerhans
6. Marasmus
7. Jaundice
8. Chyle
9. Fatty acid
10. Oxyntic cell

**Group B**

- (a) Small intestine
- (b) Insulin
- (c) Bilirubin
- (d) Food poisoning
- (e) Pepsinogen
- (f) HCl
- (g) Lacteal
- (h) Pancreatic juice
- (i) Sub-mucosa
- (j) Nutritional deficiency

**GROUP - B**

**(Short Answer-type Questions)**

**I. Answer the following (Answer each within 50 words)**

- (i) What do you mean by intracellular digestion ?
- (ii) Explain the gustatory function of the tongue.
- (iii) Write the dental formula of the permanent set of man.
- (iv) Write the sub-divisions of the pharynx and the openings discharging into the pharynx and the openings leading from the pharynx.
- (v) Mention about the divisions of the stomach of man.
- (vi) What do you mean by peristalsis and antiperistalsis ?
- (vii) What are Peyer's patches and what is their function ?
- (viii) What are the four histological layers in the alimentary canal of man from outer to inner ?
- (ix) How is the secretion of the gastric juice regulated ?
- (x) Pancreas is a mixocrine gland – Explain it.
- (xi) If enterokinase does not have a hydrolytic function in digestion, what specific role does it play?

- (xii) What are the physiological roles of insulin and glucagon? Where are these hormones secreted from the pancreas?
- (xiii) Distinguish between glycogenesis and glycogenolysis.
- (xiv) What do you understand by curdling of milk?
- (xv) What are exo- and endopeptidases?
- (xvi) What do you understand by amino- and carboxypeptidases?
- (xvii) Comment on the absorption of glucose through the intestine following digestion.
- (xviii) What are Kwashiorkor and Marasmus related to?

**2. Write short notes on**

- |                            |                                  |
|----------------------------|----------------------------------|
| (a) Dental formula of man  | (i) Gastro-intestinal hormones   |
| (b) Salivary glands of man | (j) Protein deficiency disorders |
| (c) Larynx                 | (k) Absorption of digested food  |
| (d) Pharynx                | (l) Indigestion                  |
| (e) Pristalsis             | (m) Constipation                 |
| (f) Gastric glands         | (n) Vomiting                     |
| (g) Peyer's patches        | (o) Jaundice                     |
| (h) Islet of Langerhans    | (p) Diarrhoea                    |

**3. Distinguish between**

- (a) Intracellular and Extracellular digestions
- (b) Teeth of Deciduous set and Permanent set
- (c) Cardiac stomach and Pyloric stomach
- (d) Duodenum and Ileum
- (e) Exocrine pancreas and Endocrine pancreas
- (f) Circumvallate papillae and Filiform papillae
- (g) Brunner's gland and Crypt of Lieberkuhn
- (h) Secretin and Pancreozymin
- (i) Exopeptidase and Endopeptidase
- (j) Aminopeptidase and Carboxypeptidase
- (k)  $\alpha$ -1, 4 glycosidase and  $\alpha$ -1, 6 glycosidase

**GROUP - C**

**(Long Answer-type Questions)**

1. Describe the physiology of protein digestion in human alimentary canal.
2. Describe the physiology of digestion of different food stuffs in human digestive system.
3. Draw a neat labelled diagram of human alimentary canal (Description is not required).



**RESPIRATION :**

Respiration is a catabolic process of biological oxidation that occurs either in the absence of oxygen (anaerobic respiration) or presence of oxygen (aerobic respiration). Anaerobic respiration occurs in microorganisms such as bacteria and yeast and some animal cells and tissues like erythrocytes and exercising muscle in mammals. In all other organisms aerobic respiration occurs through the process of oxygen uptake and release of carbon dioxide. In respiration potential energy (bond energy) trapped in the covalent bonds of bio-molecules is transformed into another form of energy i.e. chemical energy in the form of adenosine triphosphate (ATP).

Aerobic respiration includes external respiration and internal respiration. External respiration refers to the mechanisms by which  $O_2$  is obtained from the environment in exchange with  $CO_2$ , which is expelled from the body. This occurs at the respiratory surface area, which may be integument, gill, trachea or lungs. In internal respiration, the respiratory surface is cell or tissue. Therefore, it is also called cellular or tissue respiration. In cells  $O_2$  is utilized for production of energy and  $CO_2$  is released as a by product.

**16.1. MODES OF RESPIRATION :**

Respiration is of the following types depending on the organs involved in the process.

- (a) Cutaneous respiration
- (b) Tracheal respiration
- (c) Branchial respiration
- (d) Pulmonary respiration

**16.1.1. Cutaneous respiration :**

Many small organisms obtain  $O_2$  by diffusion through their body surfaces. They do not have any specialized respiratory organ nor do they have blood circulation. In animals that have defined circulatory system and readily permeable vascular skins, gaseous exchange occurs through the integument. Thus we find that animals like earthworms, leeches, and newly hatched fish fries are among the many animals that obtain the  $O_2$  they need through their skin. Even larger animals such as many amphibians and fishes may rely on cutaneous respiration during emergencies or use it as a supplement to the gills or lungs. The integumentary contribution to

respiration may be as low as 20 percent in dry skinned toads to 76 percent in the urodele, *Triturus* and 90 percent in giant salamander *Cryptobranchus*. In frogs, cutaneous respiration accounts for about 25% of the body's  $O_2$  requirement in normal life. During hibernation and aestivation the frog goes underground and mostly respire through skin.

The moist or mucous coated skin absorbs gaseous  $O_2$  in exchange of  $CO_2$ . The  $O_2$  diffuses through the skin and enters into the capillary plexus under the skin.

### 6.1.2. Tracheal respiration :

This type of respiration is seen in terrestrial arthropods like insects, centipedes and millipedes, in which the system comprises of a large number of chitinous tubes called **tracheae** (singular; trachea) and their branches, the **tracheoles**. These carry atmospheric air or oxygen to the tissues directly, without the need for transportation by the blood. The air enters into the system through several paired openings called **stigmata** or **spiracles** present on the lateral sides of the body. Direct exchange of the respiratory gases by the tissues occurs much faster and enables insects to maintain a higher metabolic rate particularly during flight.

In a typical example, such as in cockroach [Fig.16.1 (a)], there are ten pairs of these spiracles, of which, two pairs are present in the thorax, first pair in the mesothorax and the second pair in the metathorax and the rest eight pairs, one each in the first eight abdominal segments. The first pair of abdominal spiracles are present dorso-laterally, in the dorsal

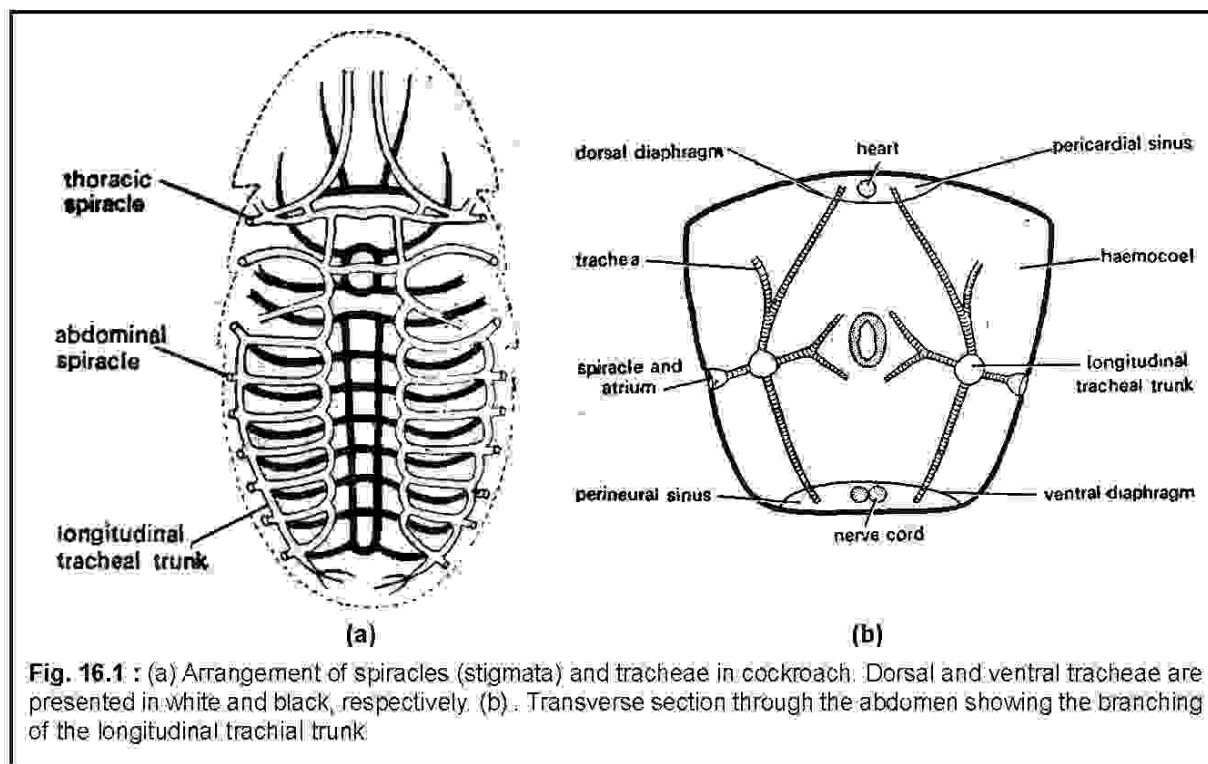

**Fig. 16.1 :** (a) Arrangement of spiracles (stigmata) and tracheae in cockroach. Dorsal and ventral tracheae are presented in white and black, respectively. (b). Transverse section through the abdomen showing the branching of the longitudinal tracheal trunk.

chitinous plate or tergum. The rest are all located on the pleura, the lateral chitinous plates joining the terga and the sterna.

Each spiracle leads into a short chamber or atrium, from which arises a main tracheal trunk. These tracheal trunks on each side divide and redivide to form fine tracheoles that enter into the tissues [Fig.16.1(b)]. The tracheae or the main trunks are ectodermal tubes supported by rings of chitin which keep the tracheae open even under conditions of reduced air pressure. These rings of chitin perform a function, similar to the cartilaginous rings of the trachea of human. The tracheoles on the

other hand are fine tubes that lack chitinous support and are filled with tissue fluid, to which they reach out (Fig.16.2). The quantum of division of these tracheoles inside a tissue, depends on its metabolic requirement. At rest, atmospheric oxygen can diffuse into the tissue and carbon dioxide can diffuse out from the tissue through the tissue fluid that fills the tracheoles.

In the active state, such as during flight, requirement of oxygen increases in the body. Several abdominal muscles that span the dorso-ventral sides of the body, called the tergo-sternal muscles, alternately contract and relax. Their contraction flattens the body and helps to drive out air from the system (**expiration**) and relaxation helps the body to assume its normal shape or volume, when air rushes into the tracheae (**inspiration**).

In the active state, due to high metabolic rate, lactic acid is produced in the muscle tissue, which makes it hyper-osmolar. As a result, the tissue fluid in the tracheoles is withdrawn into the tissue by osmosis. This enables the air to enter further deep into the tissue. The amount of carbon dioxide in the tissues and the tracheal system is sensed by receptors in the body, which control a valve to open and close the spiracles by special muscles.

The thoracic and abdominal spiracles may open and close alternately and the air may take a one-way route, in through the thoracic spiracle and out through the abdominal spiracles.

### 16.1.3. Branchial Respiration :

Respiration by gills is known as **branchial respiration**. Gills are highly vascularised gaseous exchange membranes. It occurs in sea stars; crustaceans; some molluscs; many

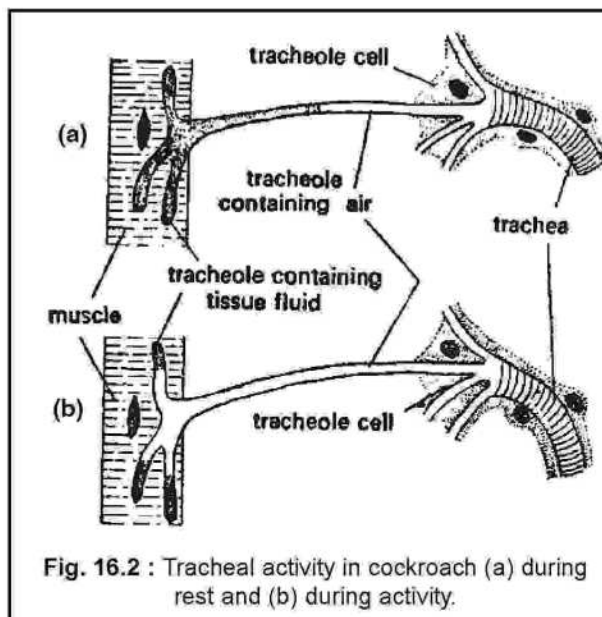
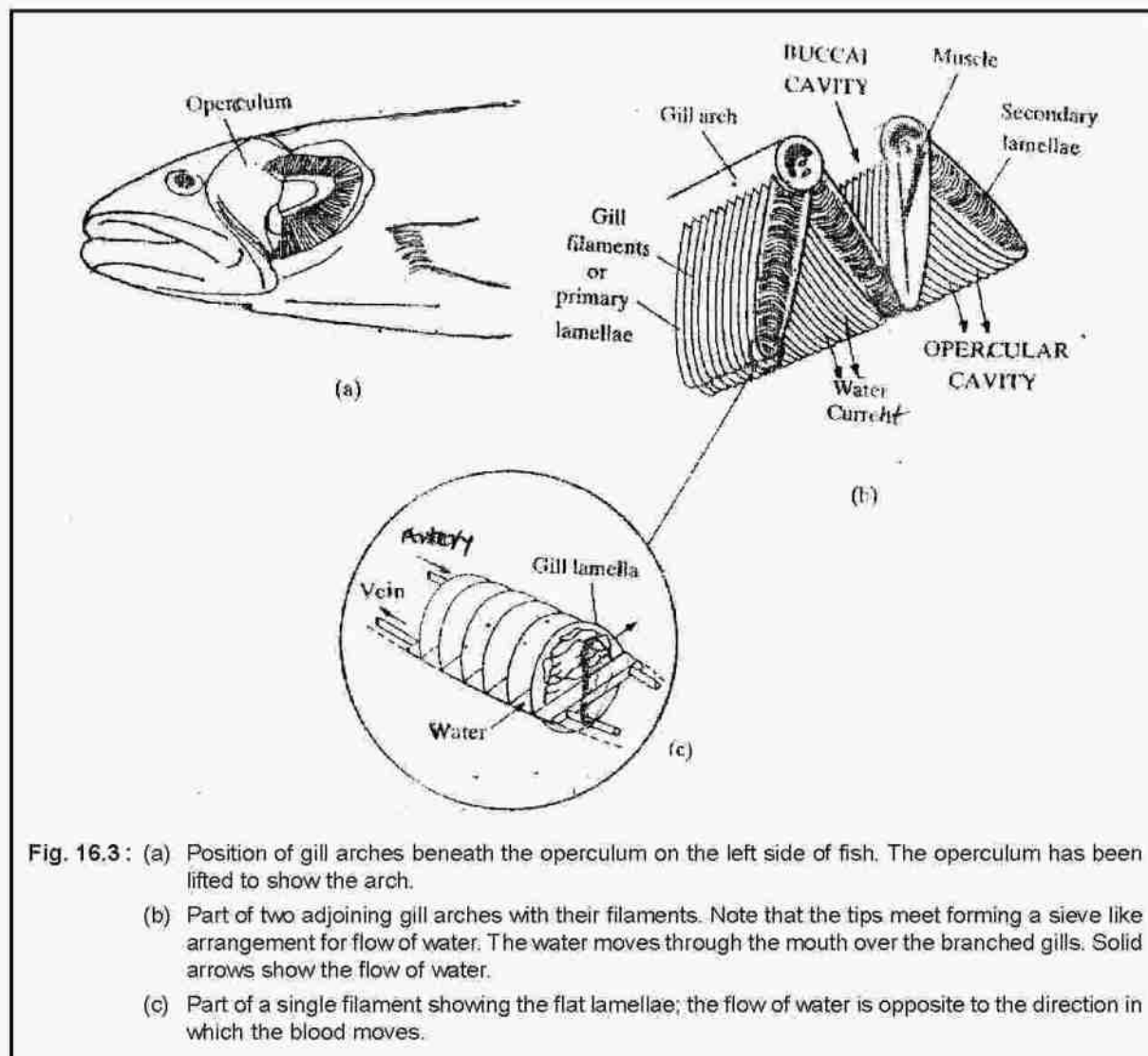

Fig. 16.2 : Tracheal activity in cockroach (a) during rest and (b) during activity.

amphibians, especially tadpole larvae and all fishes. Gill surface area must be large enough to provide adequate exchange of gases. For effective gaseous exchange a close contact between the gill and water is required. To understand how it happens let us have a close look at the surface of a gill in a bony fish. Gills are of two types : external and internal. External gills are external vascular membranous extensions having profuse gaseous exchange surface (e.g., tadpole larvae and Axolotl larva of salamander)

Internal gills are enclosed in a **branchial cavity** covered by an **operculum**. Gills of fishes consist of several gill arches on either side. From each gill arch extend two rows of gill filaments. Tips of the filaments of adjacent arches meet forming a sieve like structure through which the water flows.

In bony fishes the filaments are attached to an extremely reduced inter-branchial septum so that their distal ends hang freely in the gill chamber. This type of gill is called **filliform** or



**Fig. 16.3 :** (a) Position of gill arches beneath the operculum on the left side of fish. The operculum has been lifted to show the arch.  
 (b) Part of two adjoining gill arches with their filaments. Note that the tips meet forming a sieve like arrangement for flow of water. The water moves through the mouth over the branched gills. Solid arrows show the flow of water.  
 (c) Part of a single filament showing the flat lamellae; the flow of water is opposite to the direction in which the blood moves.



**pectenate.** In contrast, the gills of cartilaginous fishes are called **Lamellibranch** in which the gill lamellae are attached throughout their length to an elongated septum.

#### 16.1.4. Pulmonary respiration :

The respiration that takes place through lungs is called **pulmonary respiration**. Lungs are of two types: the **diffusion lungs**, which are very simple, characterized by an exchange with the surrounding environment by diffusion only. This type of lungs are found in small animals such as snails, small scorpions and some spiders. The other type i.e., **ventilation lungs** are typical to vertebrates. The air passes through a tube in to elastic lung where, gaseous exchange takes place.

### 16.2. RESPIRATORY SYSTEM IN HUMAN :

Human being, a terrestrial animal, respire by lungs, a pair of hollow air-filled bags situated in the thoracic cavity, one on either side of the heart. All vertebrates from amphibians to mammals possess a pair of lungs as respiratory organs for respiration on land. Even the aquatic vertebrates or mammals like whales, which have secondarily taken to water, respire by lungs. Respiration by lungs is **pulmonary respiration**. (L, *pulmone* : lungs)

#### 16.2.1. Respiratory Organs (Fig. 16.4) :

The respiratory system comprises of a pair of lungs and the air ways leading to and from the lungs, forming the respiratory tract. The respiratory tract begins with the nose containing a pair of openings or **external nostrils**, through which the air enters and ends with the finest of fine branches of the respiratory tract the **alveolar sacs** or **alveoli** (singular; alveolus) after passing through **larynx**, **trachea**, **bronchi** and **bronchioles**. The air way (passage) divides and redivides 23 times between the trachea and alveoli. Of these, 16 generations constitute the **conducting zone**, while the remaining 7 generations constitute the **transition** and the **respiratory zones** (Fig. 16.7). The conducting zone spans between the trachea and terminal bronchiole. The respiratory zone spans between the respiratory bronchiole and alveoli. The conducting zone simply conducts the air into the respiratory zone. No diffusion takes place in this zone. The respiratory zone airways including the alveoli are concerned with the diffusion of respiratory gases into and out of the blood.

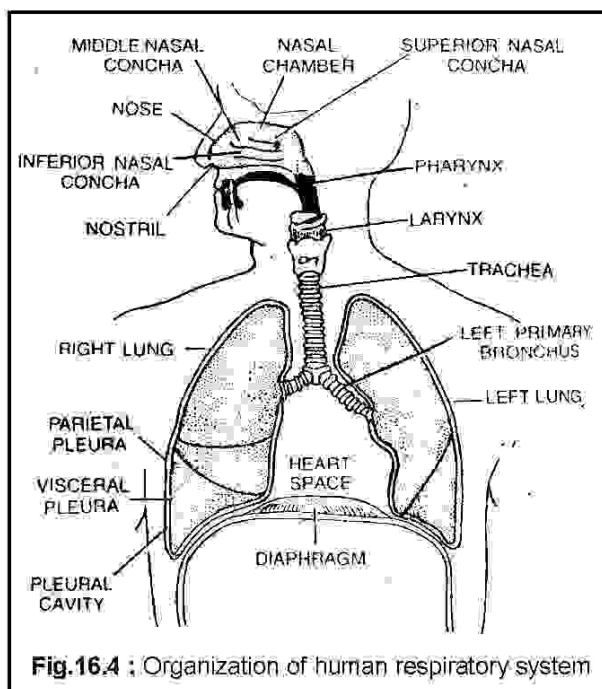

**Fig.16.4 :** Organization of human respiratory system

**16.2.1.1. The Nose :** It is a prominent feature of the human face with a small external portion followed by long internal passages. The external portion projects in front as a triangular structure, supported by a frame of bone and cartilage and contains two oval **external nostrils** or **external nares**, directed downwards.

As in the other mammals, in human, the nasal cavity is separated from the oral cavity by a horizontal **palate**. The palate is divided into an **anterior hard palate** and a **posterior soft palate**. The nasal cavity is divided by a perpendicular bony partition, the **nasal septum** into left and right nasal chambers. The nasal septum is formed by parts of nasal, ethmoid and vomer bones. A small proximal part on each side is lined by hairy skin and constitutes the **vestibule**. A small upper area of the passage on each side forms the olfactory region containing the olfactory bulbs lined by the **schneiderian membrane**, responsible for the sense of smell. The rest of the passage forms the respiratory region lined by pseudostratified epithelium containing many mucous secreting goblet cells. In this region, the air is moistened and warmed gently to equalise the temperature of the inspired air with that of the body.

The lateral wall of each nasal cavity contains scroll-like structure with three folds constituting, a **concha** projecting into the nasal cavity. It is covered by mucous membrane and is supplied with blood vessels. A concha has three divisions, designated as inferior, middle and superior from the vestibule upwards. The conchae are supported internally by bones.

The respiratory region of each nasal chamber opens into the **pharynx** by an **internal nares**. Passage of air into the pharyngeal region, however, can occur through the mouth also. This is useful when the nasal passage remains blocked for some reasons. Thus, breathing can be nasal as well as oral.

**16.2.1.2. Pharynx :** It is a region common to both digestive and respiratory systems. The pharynx is differentiated into an anterior and upper **naso-pharynx**, an anterior and lower **oro-pharynx** and a posterior **laryngo-pharynx**. The internal nostrils and the eustachial tubes from the middle ear cavity open into the nasopharynx. The oral or buccal cavity opens into the oropharynx. The soft palate projects into this region in the form of the **uvula** or **velum palatti**, which can be raised up to close the internal nostrils, at the time of swallowing to prevent the entry of food into the nasal chamber. Occasionally however, when the food is swallowed in a hurry, particles may enter through the internal nostrils into the nasal chambers causing a burning sensation.

The pharynx is a passage common to both air and food, where two passages cross each other. The **glottis**, the opening of the nasopharynx into the wind pipe is located on the floor, while the **gullet**, the opening of the oropharynx into the oesophagus is located above. However, to avoid the problem of food particles entering into the trachea, at the time of swallowing, the glottis remains covered by the epiglottis. Epiglottis is an elastic cartilaginous flap that is attached to the wall of the trachea near its origin.

**16.2.1.3. Larynx :** It is the first enlarged part of the trachea that is called the **voice box** as it contains the **vocal cords**. The vibration of the vocal cords produce the co-ordinated sound, which is interpreted as speech by the brain. Larynx is a triangular box-like structure that is supported by several paired and unpaired cartilages (Fig. 16.5). it opens into the pharynx anteriorly by the glottis and posteriorly into the trachea. The cartilages in the larynx include a pair of **thyroid cartilages** present ventrally; a ring like **cricoid cartilage**, present antero dorsally; pair of **arytenoid cartilages**; a pair of elongated or rod shaped **cuneiform cartilages**, attached to the cricoid above; and a pair of **corniculate cartilages** at the top of the arytenoid. The corniculate cartilages are also known as **cartilages of Santorini**. The thyroid cartilages join ventrally forming a protuberance or projection, known as the so-called **Adam's apple**.

**16.2.1.4. Vocal cords :** There are two pairs of mucous membranous folds that extend into the lumen of the larynx from the sides. These are yellow elastic tissue covered by non-keratinized stratified squamous epithelium. The openings between the vocal cords is actually the glottis or true glottis. The lower pair of cords are known as **true vocal cords**. These vibrate, when the expired air is forced through them. Above the true vocal cords lie a pair of **false vocal cords**, that extend from the thyroid to the arytenoid cartilage. These have no role in sound

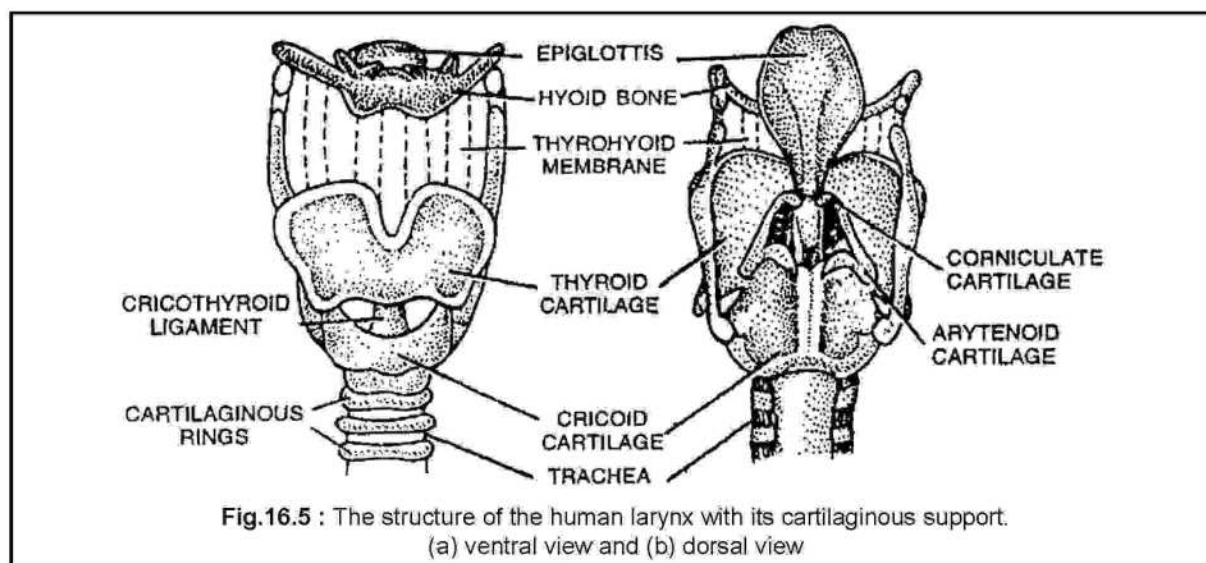

production. The vocal cords are usually thicker and longer in men than women. Thus, men produce a lower pitch sound than women.

**16.2.1.5. Trachea (Fig.16.6) :** The larynx passes into the wind pipe or trachea, 10-12 cm long, 2.5 cm wide, that extends through the neck into the thoracic cavity. The trachea is supported by a number of **incomplete C-shaped rings of hyaline cartilages**. The rings are somewhat elastic, held together by muscles in the wall. The tracheal wall around the passage is lined by mucus membrane containing cilia and goblet cells. The cartilaginous rings keep the trachea distended and prevent it from collapsing, when the air pressure in the lung falls. As the

trachea divides into bronchi and the bronchi enter into the lungs, the hyaline cartilage rings are replaced by hyaline cartilage plates. The cartilage plates decrease in size, as the bronchi divide into bronchioles. The plates completely disappear, when the diameter of bronchioles decreases to 1 mm.

**16.2.1.6. Lungs, bronchi and bronchioles (Fig.16.6) :** At the point of the entry into the thorax, the trachea divides into the first pair of branches, the **primary bronchi**.

Each primary bronchus enters into a lung lodged in a **pleural cavity** of its own. There is a pair of lungs in the thoracic cavity, one on either side of the heart. Left lung is smaller, has a **cardiac notch** and has **two lobes**. Right lung is larger and has **three lobes**. Lungs are highly elastic and spongy in texture. In the new born, it is **rosy pink** in colour and **slaty grey** in the adult due to a deposition of carbonaceous particles. Each lung is covered by two **pleural membranes**, an outer **parietal pleura** and an inner **visceral pleura**. Between the two pleural membrane, there is an obliterated **pleural cavity** containing a very little **pleural fluid**. The pleural membranes closely cover the lungs and they expand and contract in conformity with the lungs during inspiration and expiration. The two pleural coverings of the lungs are protective. They protect the lungs from friction during inflation and deflation. The inner membrane is in contact with the lungs, while the outer membrane lines the wall of the thorax and diaphragm. The pleural cavity is air tight and its pressure stays at 3-4 mm Hg, lower than that of the lung. This negative pressure is maintained during inspiration and helps the alveoli to inflate the lungs to fill any extra available space provided by the expanding thorax.

Inside the lung, the primary bronchus divides into secondary and tertiary bronchi that further divide into bronchioles. **Bronchioles** are not supported by cartilaginous rings as seen in the trachea. Each bronchiole further divides, into **terminal bronchioles** and then into **respiratory bronchioles**. Each respiratory bronchiole subdivides into alveolar ducts. Each alveolar duct terminates in a small thin-walled, sac-like **alveolus**. Within the lungs, thus, there may be twenty generations of branchings, each resulting in a narrower, shorter and more numerous tubes. Each lung is estimated to contain  $8 \times 10^6$  alveolar sacs or **alveoli**. Fig.16.7 depicts the increase in the number of airways following the division and sub-division of the trachea. The consequence is a great increase in the surface area for diffusion of gases.

The air ways beyond the larynx can be divided into two zones : **the conducting zone from the trachea to the terminal bronchioles and the respiratory zone from the respiratory bronchiole to the alveolar ducts**. Each alveolar duct opens into an **alveolus** or air sac.

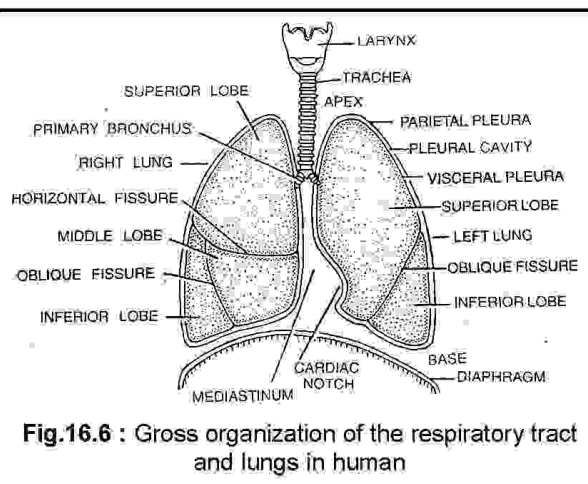

**Fig.16.6 :** Gross organization of the respiratory tract and lungs in human

The blood vessels supplying the lungs generally accompany the air ways. The conducting zone only conducts the air. No gaseous exchange takes place here, while gaseous exchange takes place in the respiratory zone. The pulmonary aorta undergoes numerous branchings. The smallest of these branches divides and redivides into a network of capillaries, which supplies the alveoli. The epithelial surfaces of the air ways to the end of the respiratory bronchioles is lined by pseudostratified ciliated epithelium containing goblet cell secreting mucous. Particulate matter such as dust and bacteria present in the inspired air stick to the mucous, which is moved by the cilia towards the pharynx and then it is either swallowed or thrown out. This helps the lungs to remain clear of dust and bacteria that enter through the inspired air. Ciliary activity can be inhibited by noxious agents such as those contained in the cigarette smoke, for several hours which may result in blockage and infection of the lung. Dust cells, present in the alveoli, also take up the dust and thus keep the airways clean.

	Name of branches	Number of tubes in branch
<b>Conducting zone</b>	Trachea	1
	Bronchi	2
		4
	Bronchioles	8
		16
Terminal bronchioles	32	
<b>Respiratory zone</b>	Respiratory bronchioles	$6 \times 10^4$
	Alveolar ducts	$5 \times 10^5$
	Alveolar sacs	$8 \times 10^6$

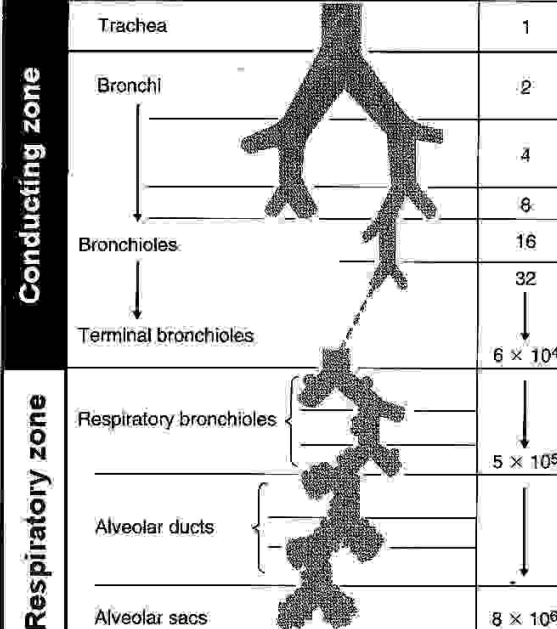
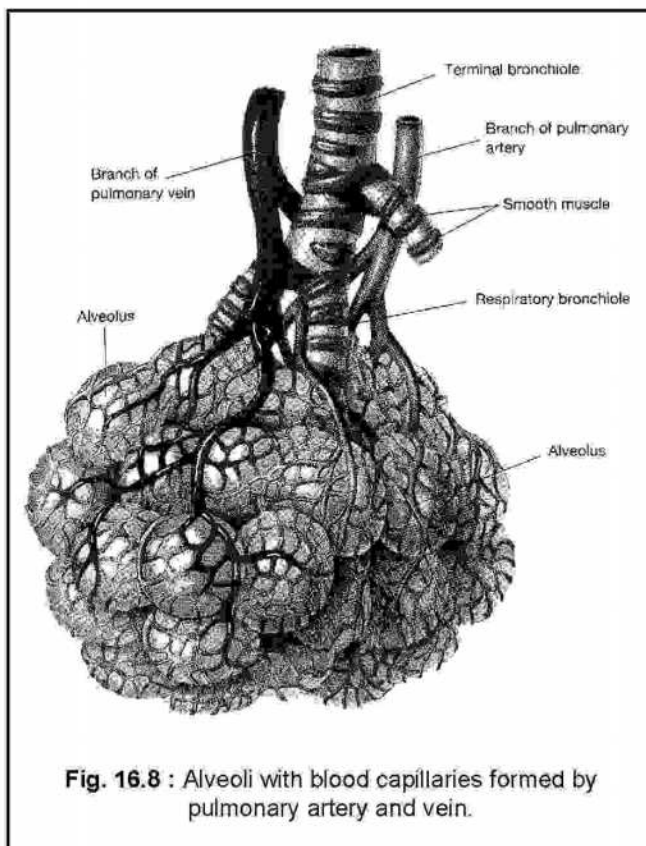

**Fig.16.7** : Division and sub-division of the trachea in the lung forming a bronchial tree

**16.2.1.7. Alveoli – Sites of gaseous exchange (Fig.16.8)** : The alveoli are tiny hollow spaces, whose open ends are continuous with the lumens of the air ways through **alveolar ducts**. Typically, the air in the alveoli, is separated by a single layer of cells. The alveoli are lined by simple squamous epithelium containing **Type I pneumocytes**. In addition to these, the alveolar epithelium, contains a small number of relatively larger and specialized cells, known as **type II pneumocytes** that produce a detergent like substance called **surfactant**. It lowers the surface tension of the fluid layer, lining the alveoli and thereby reduces the amount of effort needed to breathe in and inflate the lungs. The surfactant also speeds up the transport of oxygen and carbon dioxide between the air and the liquid, lining the alveoli and also helps to kill bacteria that reach the alveoli. It is constantly secreted and reabsorbed in the healthy lung. Without it, the surface tension of the fluid in the alveoli is about ten times higher than normal and the alveoli tend to collapse after each expiration. It also requires a much greater effort to expand them again when breathing in than when surfactant is present. The surfactant is generally a mixture of **dipalmitoylphosphatidylcholine, other lipids** and **proteins**. Surfactant begins to be produced in late fetal life. Therefore, the lungs of premature babies lack sufficient surfactant.

Consequently, the alveoli collapse following expiration. This condition is known as **respiratory distress syndrome**.

The alveolar surface in contact with the air is kept moist by mucous. In some alveolar walls, there are pores that permit the flow of air between alveoli which is useful when the air way is blocked by diseases. The alveolar wall contains capillaries, the endothelial linings, which are separated from the alveolar epithelium by a basement membrane and a very narrow interstitial space containing interstitial fluid and a loose network of connective tissue. In places, the interstitial space may be absent altogether and the epithelium of the alveoli and the endothelium of the capillaries in the wall may fuse. Thus, the blood within an alveolar capillary is separated from the air



**Fig. 16.8 :** Alveoli with blood capillaries formed by pulmonary artery and vein.

by only about  $0.2 \mu$  (micron) compared to the  $7.0 \mu$  diameter of an erythrocyte. The total surface area of the alveoli is 80 times greater than the external body surface. The alveolar lumen contains **macrophages** or **phagocytic cells**, known as **dust cells**. These cells engulf dust particles that enter into the alveoli with the inspired air.

**16.2.1.8. Rib cage and diaphragm :** The lungs are contained in the thorax, the body division between the neck and the abdomen. The thorax is a closed compartment bound at the neck by muscle and connective tissue and completely separated off from the abdomen by a large dome-shaped sheet of skeletal muscle, the **diaphragm**. The wall of the thorax is formed at the back by the vertebral column and the ribs on the sides, which are movably attached to the vertebrae behind and the sternum or breast bone in front. There are 12 pairs of ribs which encircle the thoracic cavity from sides. Ribs are of 3 types:- (Fig. 16.9)

I. **True ribs** - 1st - 7th pairs. They are attached both to the thoracic vertebrae and sternum.

II. **False ribs** - 8th - 10th pairs. They are attached to costal cartilage of 7th rib.

III. **Floating ribs** - 11th and 12th pairs. They are attached to the vertebrae but do not reach the sternum. The muscles that connect the adjacent ribs are called **intercostal muscles**. Two sets of intercostal muscles connect the ribs: **external** and **internal** (Fig. 16.10). **The**

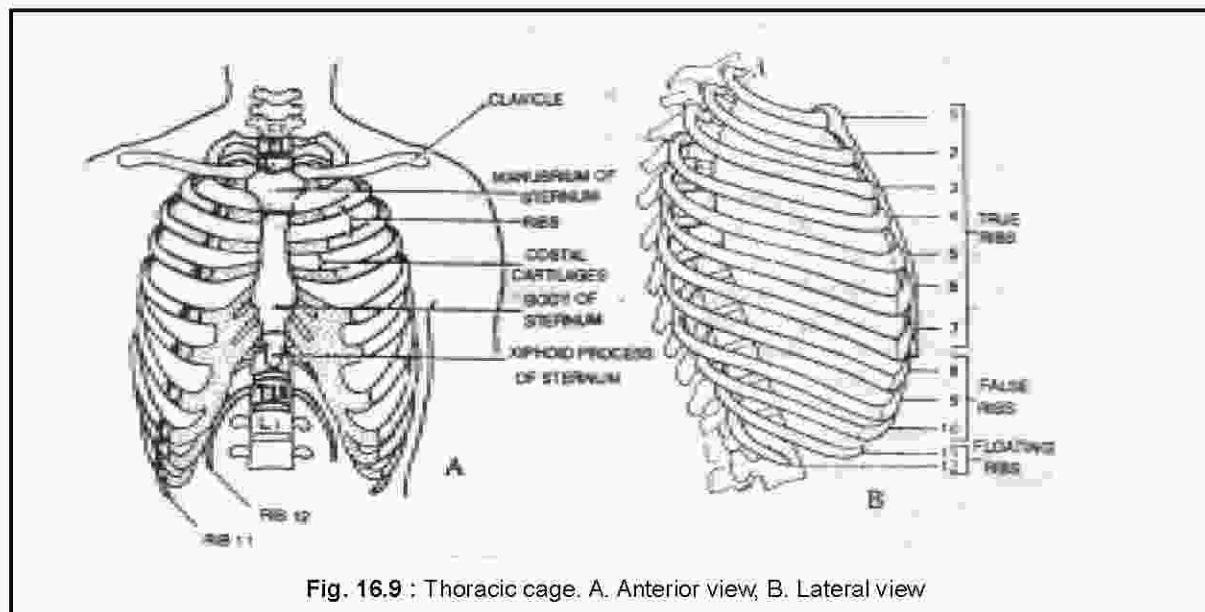

Fig. 16.9 : Thoracic cage. A. Anterior view, B. Lateral view

**external intercostal muscles are the inspiratory muscles**, which run obliquely downward and forward or inward from rib to rib. The **internal intercostal muscles are the expiratory muscles**, which run obliquely downward and backward or outward. These muscles are used during quiet respiration, while some accessory muscles, like **scalenes** and **sternocleidomastoid** are used during forced respiration (Fig.16.10).

### 16.3. MECHANISM OF BREATHING OR VENTILATION :

Each respiratory cycle comprises of two opposite physiological processes involving the lungs : **inspiration**, by which air is taken into the lungs and **expiration**, by which the used air is expelled out. Inspiration and expiration together constitute **breathing**, which is also known as **ventilation or external respiration**. Two types of breathings have been recognized : normal or quiet and forced (Table 16.1). The one described in the text below is normal or quiet breathing.

#### 16.3.1. Inspiration :

Inspiration is an active process which is brought about by the contraction of the **external intercostal muscle** and the relaxation of the **internal intercostal muscle**. This pulls the rib cage forward and outward. Concurrently, the muscles of the **diaphragm** contract, which flatten it out. By this, the volume of the thoracic cavity is increased. The air pressure in the thorax and hence, in the lungs is reduced to less than the atmospheric pressure. Air, therefore, rushes into the lungs through the respiratory tract, inflating the alveoli until the air pressure in the lungs is equal to that of the atmosphere. So our breathing is called **negative pressure breathing**.

#### 16.3.2. Expiration :

Expiration is a passive process under resting conditions. The events are a reversal of those of the inspiration. The **external intercostal muscles** relax and the **internal intercostal**

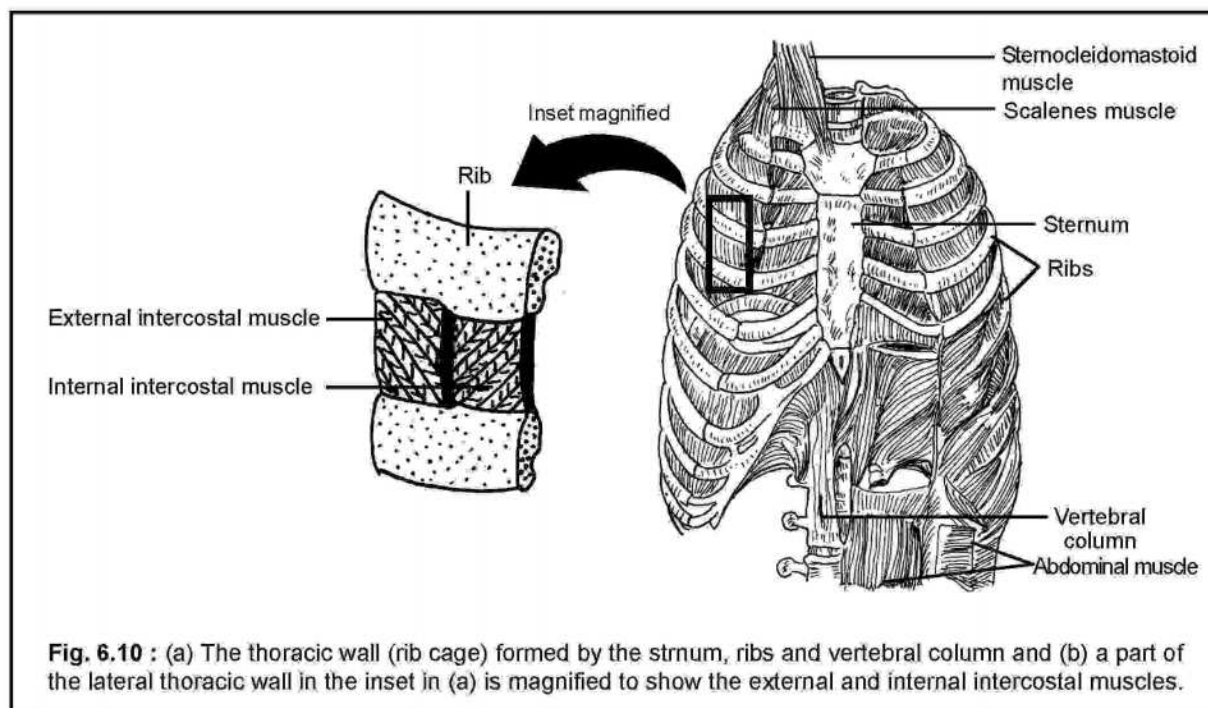

**muscles** contract. The rib cage moves backward and inward. The muscles of the diaphragm relax as a result it becomes dome shaped, pushing it up into the thoracic cavity. All these events reduce the volume of the thoracic cavity and raise the intrapulmonary pressure more than that of the atmosphere. Consequently, the air is forced out of the lungs.

**Table 16.1: Comparative account of inspiration and expiration during quiet and forced breathing.**

	Normal or Quiet	Forced
<b>Inspiration</b>	The diaphragm contracts. External intercostal muscles contract. The ribs move forward and outward. The thoracic volume increases. The intrapulmonary pressure decreases to about $-3$ mm Hg.	The action of the external intercostal muscles aided by the scalenes and sternocleidomastoid muscles decreases the intrapulmonary pressure to $-20$ mm Hg.
<b>Expiration</b>	The diaphragm relaxes. Internal intercostal muscle contracts. The ribs move backward and inward. The thoracic volume decreases. The intrapulmonary pressure increases to about $+3$ mm Hg.	The contraction of the abdominal muscles and internal intercostal muscles decreases the intrapulmonary pressure to about $+30$ mm Hg.



Under condition of heavy exercise, forced breathing takes place. When this happens additional muscles are brought into action during inspiration and expiration. **Scalenes** and **sternocleidomastoid muscles** along with external intercostal muscle and diaphragm bring about inspiration. The **abdominal muscles** along with internal intercostal muscles and diaphragm bring about expiration. This type of ventilation also occur during sneezing and coughing. A comparative account of inspiration and expiration during quiet and forced breathing is presented in Table-16.1.

### 16.3.3. Control of ventilation or Breathing :

Under normal condition, breathing is controlled involuntarily and we are not conscious about it. Involuntary control is brought about by a breathing centre located in the **pons** and **medulla oblongata** of the brain. The ventral part of this centre is the **inspiratory centre** and the dorsal and lateral parts inhibit inspiration and stimulate expiration and hence form the **expiratory centre**. Nerve fibres reach out from these inspiratory and expiratory centres to the respective intercostal muscles and also by the phrenic nerve to the muscles of the diaphragm. Nerve impulses via these nerve fibres control the rhythmic movements of these muscles and hence, breathing. The bronchial tree, comprising of the bronchi and the bronchioles is also connected to the medulla of the brain by the vagus nerve.

Inspiration is also controlled by the **stretch receptors (proprioceptors)** located in the bronchial tree and the lung wall, which limit maximum inspiration. These receptors send impulses to the inspiratory centre to inhibit it when maximum inflation has reached. Impulses also reach the expiratory centre to stimulate it. External intercostal muscles relax as a result. This is known as **Herring-Breuer Reflex**. When inspiration is stopped, these receptors are no longer stimulated.

Besides, there are **chemoreceptors** in the medulla and in the **carotid and aortic bodies** in the large aorta that sense the blood for its carbon dioxide tension rather than the oxygen tension. When the carbon dioxide content rises, as during exercise, nerve impulses are sent out by them to the inspiratory centre and via this centre to the respiratory muscles to increase the rate of ventilation. Carbon dioxide, if allowed to accumulate, is harmful as it forms carbonic acid by combining with the water of the plasma. Carbonic acid dissociates to form  $\text{HCO}_3^-$  and  $\text{H}^+$ . Increased  $\text{H}^+$  concentration or decreased pH of the blood can denature the proteins particularly the enzymes. An increase of 0.25% in the concentration of carbon dioxide in the blood, doubles the ventilation rate. Reduction in oxygen concentration of 15 % only has the same effect. Since oxygen is available in higher concentration its effect is small in comparison to carbon dioxide. Chemoreceptors sensitive to  $\text{O}_2$  tension are also located in the medulla and the aortic bodies.

Within limits, the rate of breathing is also under voluntary control as is seen by the ability to hold the breathe. Voluntary control of breathing is also used during forced breathing, speech, singing, sneezing and coughing. Under these circumstances, the cerebral hemispheres send impulses from their centres to the medulla and then from the medulla to the breathing centre to carry out an approximate response.

Control of inspiration by Herring-Breuer reflex of the stretch receptors and the control through chemoreceptors are examples of negative feedbacks. Normal breathing rate per minute is 16-20.

#### 16.4. LUNG VOLUMES AND CAPACITIES :

Human takes recourse to either quiet or forced breathing depending upon the situation. The lungs are very flexible and can hold variable volumes of air under different situations. However, there is an upper limit to the stretching of the lungs. Therefore, each lung has a volume range of holding air during quiet and forced breathing. The **lung volumes** and **lung capacities** (two or more lung volumes taken together) are described in Table-16.2 and Fig. 16.11. All four volumes added together make up the total lung capacity i.e., the maximum volume to which the lungs can be expanded. An instrument that measures the lung volumes and capacities is known as a **spirometer**.

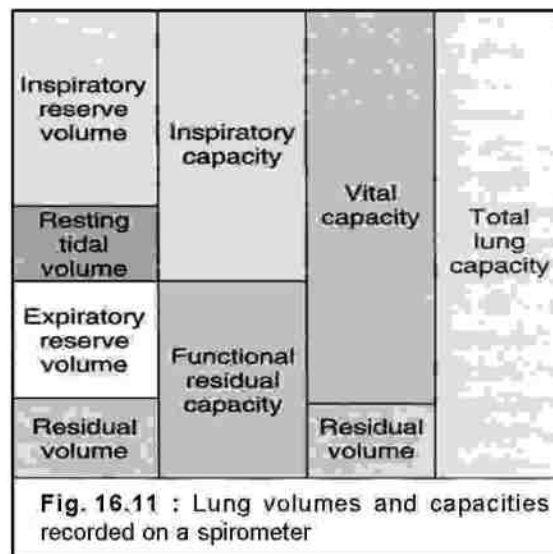

**Table - 16.2 : Different lung volumes and capacities**

<b>Lung Volumes :</b>	
Tidal volume (TV)	The volume of air inspired or expired in a quiet respiratory cycle. It is about 500 ml.
Inspiratory reserve volume (IRV)	It is the extra volume of air that can be inspired during forced breathing after normal inspiration. It is about 2000 to 3000 ml.
Expiratory reserve volume (ERV)	It is the extra volume of air that can be expired during forced breathing after normal inspiration.
Residual volume (RV)	The volume of air remaining in the lungs after a maximal expiration. It is about 1000 ml to 1500 ml.
Anatomical dead space	The volume of air remaining in the respiratory tubes of the conducting zone following inspiration (150 ml.)
<b>Lung Capacities :</b>	
Vital capacity (VC)	The maximum volume of air that can be expired after a maximum inspiration. $VC = TV + IRV + ERV$ . It is about 3.5 - 4.5 litres
Inspiratory capacity (IC)	The maximum volume of air that can be expired following a normal tidal expiration. $IC = TV + IRV$ . It is about 2.5 - 3.0 litres
Functional residual capacity (FRC)	The volume of air remaining in the lungs after a normal tidal expiration. $FRC = ERV + RV$
Total lung capacity (TLC)	The total volume of air in both lungs following a maximal inspiration (Vital capacity + Residual volume) $TLC = VC + RV$ . It is about 5.0 - 6.0 litres

**16.5. TRANSPORT OF RESPIRATORY GASES (Fig.16.12) :**

Air is a mixture of several gases, of which, oxygen and carbondioxide are involved in respiration. Air has mass and therefore exerts a pressure. The pressure exerted by individual gases in a gaseous mixture is called its **partial pressure**, denoted by P. The sum total of the partial pressures of gases in the air is 760 mm Hg at sea level. The partial pressure of oxygen or  $P_{O_2}$  is 20.98% of 760 mm Hg. = 160 mm Hg at sea level. Similarly, the  $P_{CO_2}$  is 0.04% of 760 mm Hg = 0.3 mm Hg at sea level. The air that we breath becomes contaminated with water vapour, while it passes through the respiratory tract. The percentage of oxygen decreases to 19.67. Hence,  $P_{O_2}$  in the inspired air is calculated as 149.3 mm Hg. This air is known as humified air. The partial pressures of the different constituent gases in the inspired air is given below.

Gas	% in inspired humified air	Partial pressure (mm Hg)
$O_2$	19.67	149.3
$CO_2$	0.04	0.3
Water vapour	6.2	47.0

The humified air enters the lung alveoli and gets mixed up with the air that is already present (residual volume). The percentges and the partial pressures of the gases as a result change in the alveoli as noted below.

Gas	% in alveolar air	Partial pressure (mm Hg)
Oxygen	13.8	105
Carbon dioxide	5.3	40
Water vapour	6.2	47

The blood arriving at the lung alveoli through the pulmonary arterial capillaries in the alveolar wall has a lower  $P_{O_2}$  and a higher  $P_{CO_2}$ . A comparison between the two is summarised below.

Respiratory gas	Partial pressure in alveolar air (mm Hg)	Partial pressure in the pulmonary arterial blood (mm Hg)
Oxygen	105	40
Carbon dioxide	40	46

Table-16.3

Comparative  $P_{O_2}$  and  $P_{CO_2}$  in the alveolar air and pulmonary blood vessels and the direction of diffusion of  $O_2$  and  $CO_2$ . The direction of flow of blood is indicated by arrows.

	$P_{O_2}$ (mm Hg)	$P_{CO_2}$ (mm Hg)
→ Alveolus	105	40
$O_2$ ↓		
Pulmonary vein	100	40
$O_2$ ↓		
Systemic artery	100	40
$O_2$ ↓		
Cells	40	46
$CO_2$ ↓		
Systemic veins	40	46
$CO_2$ ↓		
Pulmonary artery	40	46

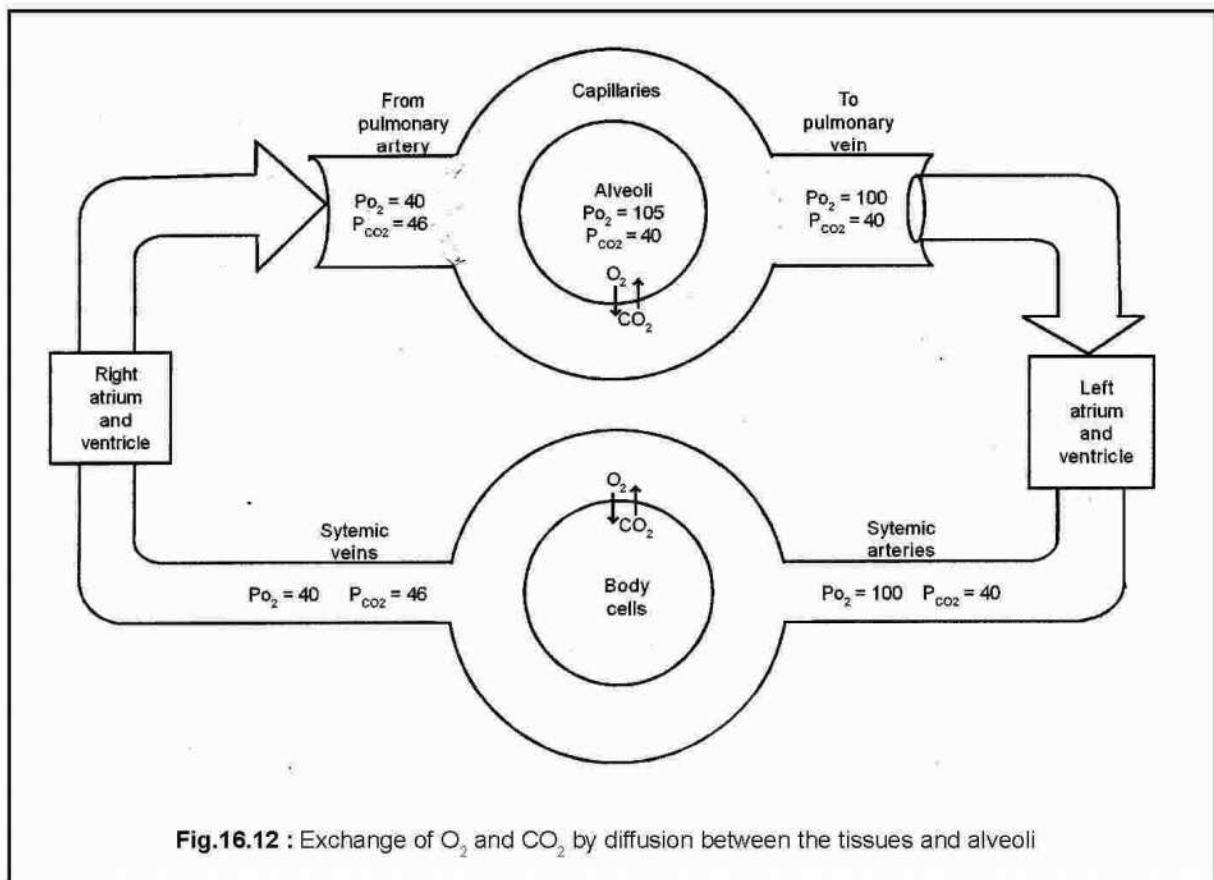

Fig.16.12 : Exchange of  $O_2$  and  $CO_2$  by diffusion between the tissues and alveoli

Gases always flow from a region of higher partial pressure to a region of lower partial pressure. In the alveolar air, the  $P_{O_2}$  is 100-105 mmHg, while the  $P_{O_2}$  in the pulmonary arterial blood is only 40 mm Hg. This blood reaches the alveoli after releasing oxygen at the tissue level. Oxygen, therefore, diffuses from the alveolar air into the pulmonary arterial blood. The thin wall separating the blood in the capillaries and the air in the alveoli is no barrier to this movement. Similarly, the  $P_{CO_2}$  is greater i.e. 46 mm Hg in the pulmonary arterial blood than the  $P_{CO_2}$  of the alveolar air i.e. 40 mm Hg.  $CO_2$ , therefore, diffuses out from the arterial blood into the alveolar air. The diffusion of oxygen and carbon dioxide in opposite direction continues till equilibrium is established on either side. Thus,  $P_{O_2}$  of the pulmonary blood rises from 40 to 100 mm Hg and that of carbon dioxide falls from 46 to 40 mmHg. This process is known as **oxygenation**. Following oxygenation, the pulmonary arterial blood changes to venous blood that is drained to the heart and then to tissues for delivery of oxygen.

Oxygen is transported from lungs to different parts of the body and carbon dioxide is transported from different parts of the body to lungs. Blood serves as a medium for this transport.

**16.5.1. Transport of oxygen :** Oxygen is transported by the blood in two forms.

### I. As dissolved oxygen

Oxygen is soluble in water. Water is the major component of blood plasma. A fraction of the total oxygen is transported in dissolved state in the plasma. About 3% of oxygen is transported in this form.

### II. As oxyhaemoglobin

R.B.C. contains a red-coloured respiratory pigment in its cytoplasm called haemoglobin (Hb). Haemoglobin is a conjugate protein having a protein part called **globin** and a non protein part called **heme**. Structurally, it is made up of four sub-units. Each sub-unit contains a heme conjugated to a globin polypeptide. A heme is an iron-containing porphyrin in ferrous ( $Fe^{2+}$ ) valency state. The iron atom is bonded to globin polypeptide. There are two each of  $\alpha$  and  $\beta$  globin polypeptides. Molecular oxygen ( $O_2$ ) binds to the iron atom without changing its valency state. Each heme binds a molecule of oxygen. Thus, on saturation, haemoglobin is bound to four molecules of oxygen.

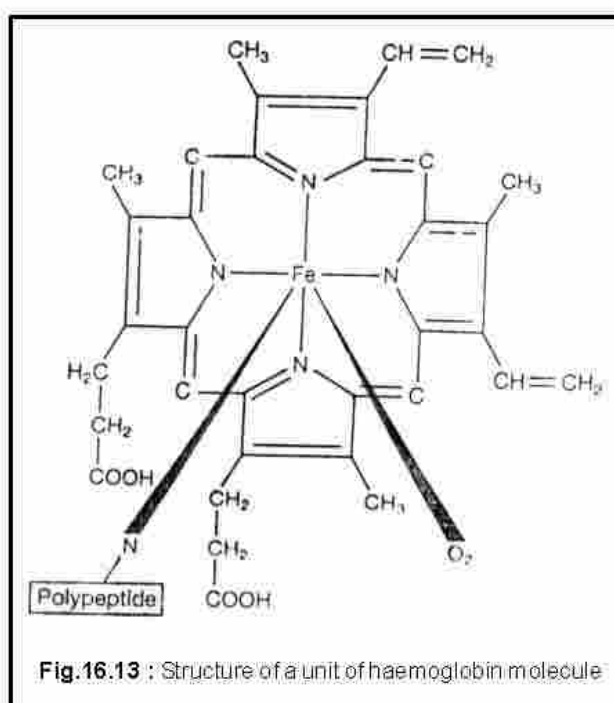
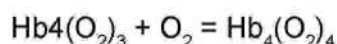
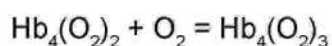
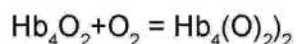
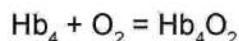

Fig.16.13 : Structure of a unit of haemoglobin molecule

However, this binding does not occur all at once. The binding of one molecule facilitates the binding of the second and so on. This type of binding is known as cooperative or allosteric binding. Haemoglobin on binding to oxygen forms **oxyhaemoglobin**. This type of binding is depicted below.



**Myoglobin** is another such conjugate protein, present in the muscle. Structurally, it is more or less similar to haemoglobin. However, it contains one heme and one globin chain. It, thus, carries one molecule of oxygen. It can store oxygen in the muscle tissue and this is particularly important for diving mammals like seals, whales and porpoises who spend a lot of time under water.

### 16.5.2. Haemoglobin and oxygen association / dissociation curve :

**16.5.2.1. Effect of  $P_{\text{O}_2}$  on haemoglobin saturation (Fig. 16.14) :** The quantitative relationship between percentage saturation of haemoglobin and  $P_{\text{O}_2}$  is presented by an oxygen association/ dissociation curve (Fig. 6.15). The curve is an S-shaped curve with a steep rise between 10 and 60 mm Hg  $P_{\text{O}_2}$  and a flat part between 70 and 100 mm Hg  $P_{\text{O}_2}$ . Thus, the extent to which haemoglobin combines with oxygen increases very rapidly from 10 to 60 mm Hg so that at a  $P_{\text{O}_2}$  of 60 mm Hg, 90% of the total haemoglobin is combined with oxygen. From this point on, a further increase in  $P_{\text{O}_2}$  produces only a small increase in oxygen binding.

The importance of this plateau or flat region of the curve at higher  $P_{\text{O}_2}$  lies in many situations, including high altitudes and cardiac and pulmonary diseases, in which  $P_{\text{O}_2}$  of the alveolar or arterial blood is less. Even if the  $P_{\text{O}_2}$  falls below the normal value of 100 mm Hg to 60 mm Hg, the total quantity of oxygen carried by haemoglobin will decrease by only 10%, since at this  $P_{\text{O}_2}$ , haemoglobin saturation is still close to 90%. The upper flat portion, therefore, provides an excellent safety factor in the supply of oxygen to the tissues.

Since haemoglobin is nearly fully saturated at 100 mm Hg only further increase in  $P_{\text{O}_2}$  or breathing 100% pure oxygen adds very little oxygen to the blood.

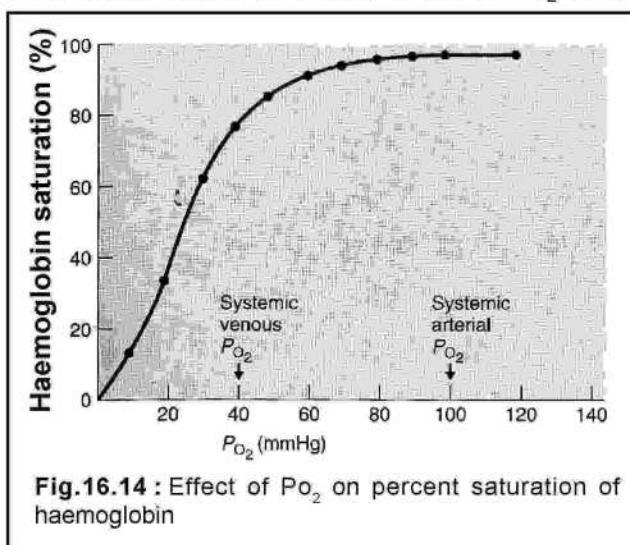

This is for normal people at sea level. Persons suffering from lung diseases or initially living at higher altitudes would benefit from such a situation, which would result in higher oxygen carriage.

The plasma and erythrocytes in the pulmonary arterial blood entering the lungs have a  $P_{O_2}$  of 40 mm Hg. At this  $P_{O_2}$  haemoglobin is 75% saturated. Oxygen diffuses from the alveolar air because of its higher  $P_{O_2}$  than the pulmonary arterial blood. Diffusion continues till the  $P_{O_2}$  of the pulmonary blood rises from 40 mm Hg to 100 mm Hg. Similarly, carbon dioxide diffuses out into the alveolar air from the pulmonary blood because of its higher partial pressure of 46 mm Hg, than the 40 mm Hg  $P_{CO_2}$  of the alveolar air. Diffusion continues till  $P_{CO_2}$  of the pulmonary blood falls to 40 mm Hg.

**16.5.2.2. Effect of  $P_{CO_2}$ ,  $[H^+]$ , temperature and diphosphoglycerate concentration on oxygen-haemoglobin dissociation :** Several factors influence the dissociation of oxyhaemoglobin and the release of oxygen. Among these are **hydrogen ion concentration (pH), temperature** and **2, 3-diphosphoglycerate (2, 3-DPG)** (Table 16.4). At higher temperature and lower pH, the oxyhaemoglobin dissociation curve shifts to the right i.e. higher  $P_{O_2}$  is required for haemoglobin to bind to oxygen. Alternately speaking, at higher temperature and lower pH, the affinity of haemoglobin for oxygen decreases [Fig. 16.15 (a) and (b)]. At higher body temperature, such as during heavy exercise and fever, the oxyhaemoglobin dissociates at the tissue level and thus the delivery of  $O_2$  to the tissues increases in conformity with the demand. The effect of pH on this dissociation curve is described as **Bohr effect**.

The concentration of 2, 3-DPG has also a bearing on the oxyhaemoglobin dissociation curve. Erythrocytes lack mitochondria and hence, they obtain their energy from glycolysis or anaerobic breakdown of glucose. 2, 3-DPG, a product formed from 3-phosphoglycerate

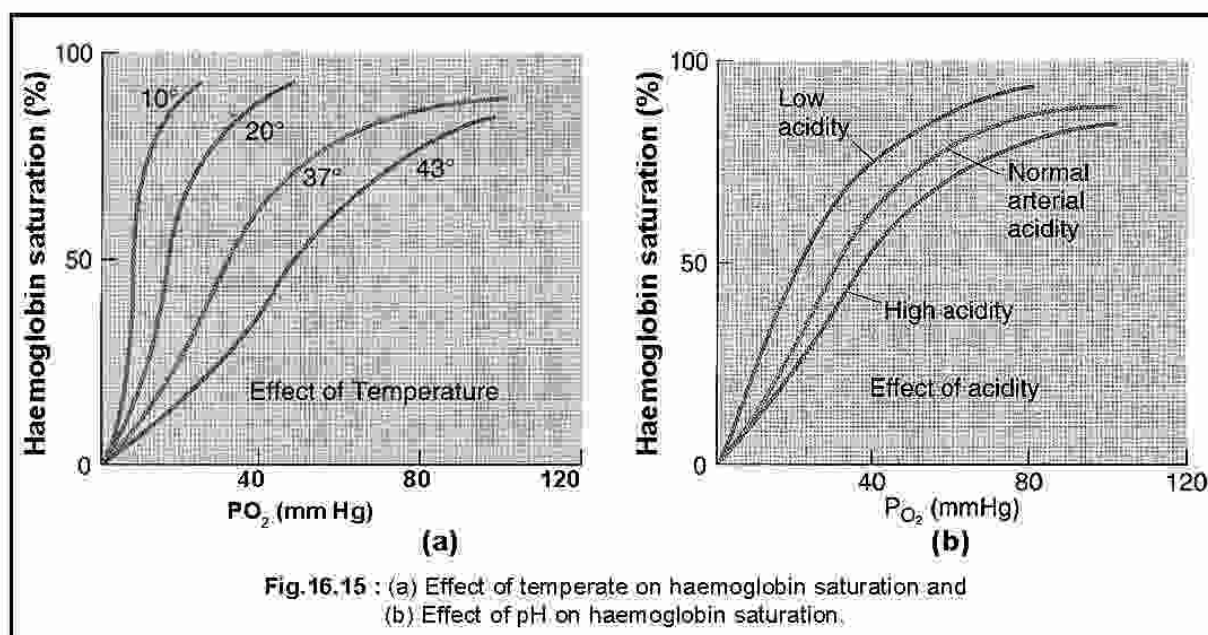

during glycolysis, is plentiful in erythrocytes. It is a highly charged ion (anion) that binds to the  $\beta$ -globin polypeptide chain of deoxyhaemoglobin and thus affects the oxyhaemoglobin dissociation curve. An increased 2, 3-DPG in the red cells shifts the curve to the right side (Fig. 16.16). It favours the dissociation of oxyhaemoglobin into deoxyhaemoglobin and oxygen. Thus, 2, 3-DPG favours oxygen unloading from oxyhaemoglobin at the tissue level. At higher altitude, erythrocytes form more 2, 3-DPG. This facilitates the unloading of  $O_2$  at the tissue level. A higher concentration of 2, 3-DPG also helps  $O_2$  delivery to the tissues in anemia patients.

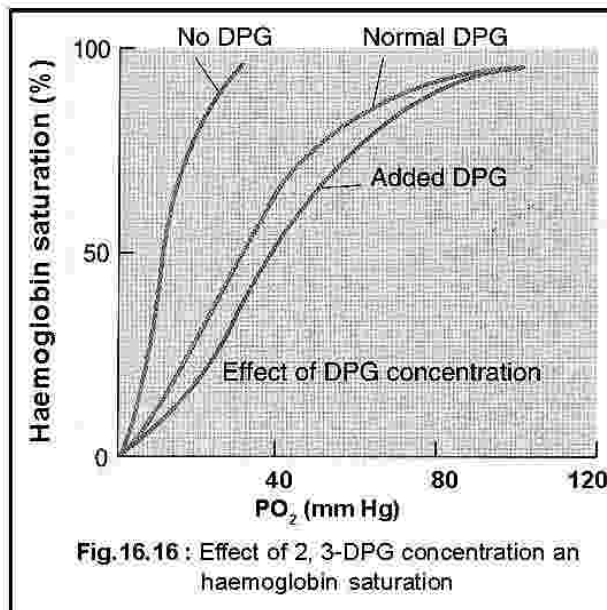

Fig.16.16 : Effect of 2, 3-DPG concentration on haemoglobin saturation

Factor	Affinity for Oxygen	Feature of low curve	Inference
↓ pH	Decreased	Shifts to the right	Called Bohr effect. At lower pH (more $H^+$ ), oxyhaemoglobin dissociates into deoxyhaemoglobin and $O_2$ .
↑ Temperature	Decreased	Shifts to the right	Increases oxygen unloading during exercise and fever.
↑ 2, 3-DGP	Decreased	Shifts to the right	Increases oxygen unloading in adaptation to anemia and high altitude living.

### 16.5.3. Transport of Carbon dioxide :

During oxidation of substrates at the cellular level, carbon dioxide is produced which diffuses out into the blood capillaries and transported to lungs for removal. Transport of carbon dioxide occurs in three major forms.

#### I. As dissolved carbon dioxide :

Carbon dioxide is sparingly soluble in water forming carbonic acid ( $H_2CO_3$ ). So it is transported in dissolved condition by the blood plasma. About 7% of  $CO_2$  is transported in this form.

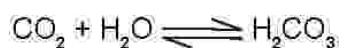



**II. As carbaminohaemoglobin :**

The globin part of haemoglobin helps in the transport of carbon dioxide. The terminal amino group of globin polypeptide combines with carbon dioxide to form carbaminohaemoglobin.



Carbaminohaemoglobin is formed at the level of the tissue and dissociates at the level of lungs. Carbaminohaemoglobin is formed when haemoglobin is in deoxygenated form as oxyhaemoglobin can not hold as much of  $\text{CO}_2$  as deoxyhaemoglobin. About 23% of carbon dioxide is transported by this process.

**III. As bicarbonates**

About 70% of carbon dioxide is transported by this method. After diffusing from the tissue into the blood capillaries, it enters into RBC. In the cytoplasm of RBC, carbon dioxide combines with water to form carbonic acid ( $\text{H}_2\text{CO}_3$ ) in the presence of an enzyme carbonic anhydrase. Carbonic acid spontaneously dissociates and liberates bicarbonate ions ( $\text{HCO}_3^-$ ) and protons ( $\text{H}^+$ ).  $\text{HCO}_3^-$  pass out from the RBC to the plasma. To restore ionic balance and electrochemical neutrality, chloride ions diffuse from the plasma into RBC. This is called **chloride shift** or **Hamburger shift**.

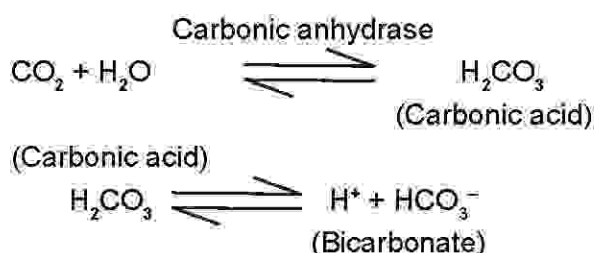

Inside the RBC, chloride ions combine with potassium ions to form KCl. Whereas,  $\text{HCO}_3^-$  in the plasma combines with  $\text{Na}^+$  to form sodium bicarbonate ( $\text{NaHCO}_3$ ).  $\text{NaHCO}_3$  is carried by the blood to the lung alveoli, where it dissociates to release  $\text{CO}_2$ . Oxyhaemoglobin after releasing oxygen combines with  $\text{H}^+$  to form reduced haemoglobin, HHb.

At the level of the lungs, these reactions occur in a reverse way. Reduced haemoglobin becomes oxygenated forming oxyhaemoglobin and releases  $\text{H}^+$ .  $\text{Cl}^-$  ions of KCl diffuse out of RBC and react with  $\text{NaHCO}_3$  in the plasma forming NaCl and liberating  $\text{HCO}_3^-$  ions.  $\text{HCO}_3^-$  combine with  $\text{H}^+$  ions inside RBC and form carbonic acid. The latter dissociates in the presence of carbonic anhydrase to produce  $\text{H}_2\text{O}$  &  $\text{CO}_2$ . Carbon dioxide diffuses out through the lungs. About 4 ml of  $\text{CO}_2$  is released through the lungs by 100 ml of venous blood.

**16.5.4. Gaseous exchanges at tissue and alveolar levels :**

Two processes, such as Chloride Shift (Hamburger Shift) and Haldane Effect have been described to explain about gaseous exchanges at the tissue and alveolar levels, respectively.

**16.5.4.1. Gaseous exchange at the tissue level : Chloride Shift (Hamburger Shift)** [Fig. 16.7 (c)] explains about the gaseous exchange at the tissue level. This phenomenon has already been described in the Section 16.5.3 on Transport of  $\text{CO}_2$ . However, in this section, we make an attempt to explain about the unloading of  $\text{O}_2$  from oxyhaemoglobin at the tissue level. Recall that following the buildup of  $\text{H}_2\text{CO}_3$  in RBC cytoplasm of the systemic arterial capillaries, undergoes a spontaneous dissociation into  $\text{H}^+$  and  $\text{HCO}_3^-$ . Thus, there is an increase in the  $\text{H}^+$  concentration in the RBCs. Since, haemoglobin has a greater affinity for  $\text{H}^+$  than  $\text{O}_2$ , oxyhaemoglobin dissociated into deoxyhaemoglobin and  $\text{O}_2$ .  $\text{O}_2$  diffuses into the tissues based on the difference in the partial pressures of  $\text{O}_2$  between the two sides. Excess of  $\text{H}^+$  is buffered in combination with deoxyhaemoglobin.

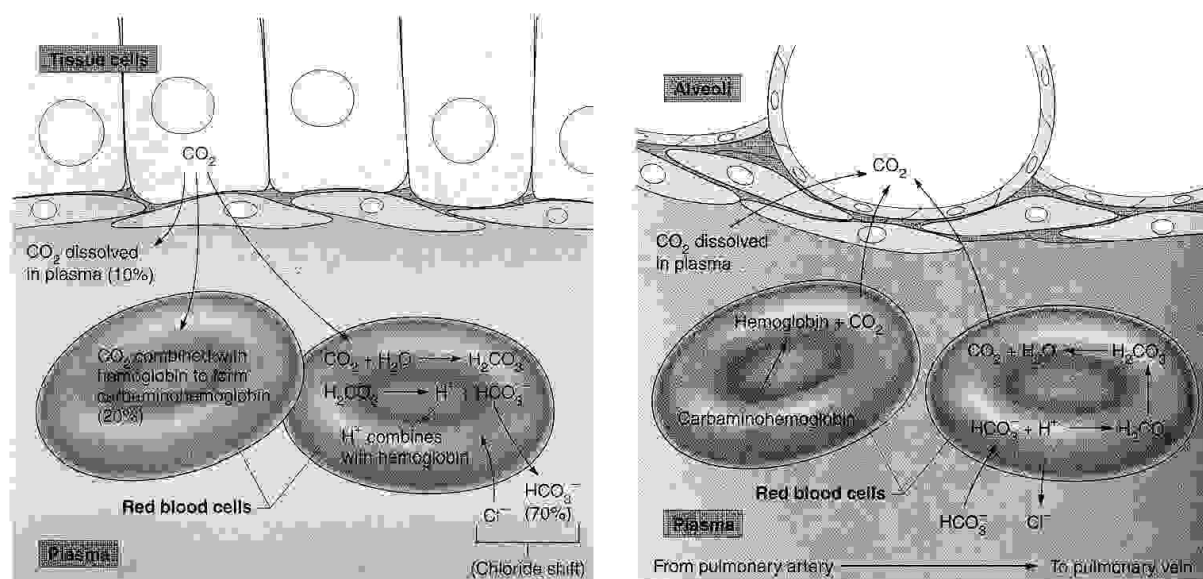

[Fig.16.17 : (a) Chloride shift or Hamburger's phenomenon operating in erythrocytes at the tissue level and (b) Haldane effect and release of  $\text{CO}_2$  into the alveoli at the alveolar capillary level.]

**16.5.4.2. Gaseous exchange at the alveolar level :** Following the unloading of  $\text{O}_2$  at the tissue level,  $\text{CO}_2$  generated in the tissues, diffuses into the blood based on the difference in partial pressures of  $\text{CO}_2$  on both sides.  $\text{CO}_2$  is carried as bicarbonates to the lung via the heart. The blood containing deoxyhaemoglobin in the RBCs and bicarbonates in the plasma returns to the lungs via the heart and then pulmonary artery. This time again, due a partial pressure difference,  $\text{O}_2$  gets into the pulmonary arterial blood and  $\text{CO}_2$  gets out of it into the alveolus. This process is explained by Haldane Effect [Fig. 16.17 (b)]. The sequence of events is exactly reverse of what happens in the Chloride Shift. Due to a higher  $\text{Po}_2$  in the pulmonary arterial blood. This makes way for association of  $\text{O}_2$  with deoxyhaemoglobin, consequently forming oxyhaemoglobin. This is followed by an exchange of  $\text{Cl}^-$  with  $\text{HCO}_3^-$  in the RBC. The released  $\text{H}^+$  from the deoxyhaemoglobin reacts with  $\text{HCO}_3^-$  in the RBC to form  $\text{H}_2\text{CO}_3$ . When there is a

build-up of  $\text{H}_2\text{CO}_3$ , it spontaneously dissociates into  $\text{H}_2\text{O}$  and  $\text{CO}_2$ .  $\text{CO}_2$  diffuses into the alveoli and then expelled out by expiration. The blood, known as oxygenated blood is carried to the tissues by the pulmonary vein via the heart and then systemic artery.

#### 16.5.5. Acid-base regulation :

The blood within the arteries has an average pH of 7.40. This pH is maintained all throughout by buffering mechanisms. When the pH falls below 7.35, the pathological condition is known as **acidosis** and when it is raised above 7.45, it is known as **alkalosis**. A greater part of  $\text{CO}_2$ , generated in the tissues through aerobic respiration is transported to the lungs as bicarbonates. Primarily  $\text{CO}_2$  reacts with  $\text{H}_2\text{O}$  forming  $\text{H}_2\text{CO}_3$  in the erythrocytes, catalyzed by the enzyme, **carbonic anhydrase**.  $\text{H}_2\text{CO}_3$  is formed in the plasma, but to a lesser extent. When  $\text{H}_2\text{CO}_3$  concentration builds up, it spontaneously dissociates into  $\text{H}^+$  and  $\text{HCO}_3^-$ . Non-volatile metabolic acids like, lactic acid, fatty acids and ketone bodies also generate  $\text{H}^+$ . A major part of the  $\text{H}^+$  is buffered by haemoglobin in erythrocytes and different buffering mechanisms in the plasma.  $\text{HCO}_3^-$ , generated in erythrocytes is exchanged with  $\text{Cl}^-$  of the plasma at the tissue level. (refer to chloride shift).  $\text{HCO}_3^-$  functions as an excellent buffer and absorbs excess of  $\text{H}^+$ , generated by nonvolatile acids. Any excess of the  $\text{H}^+$  is excreted by the kidneys in the urine.

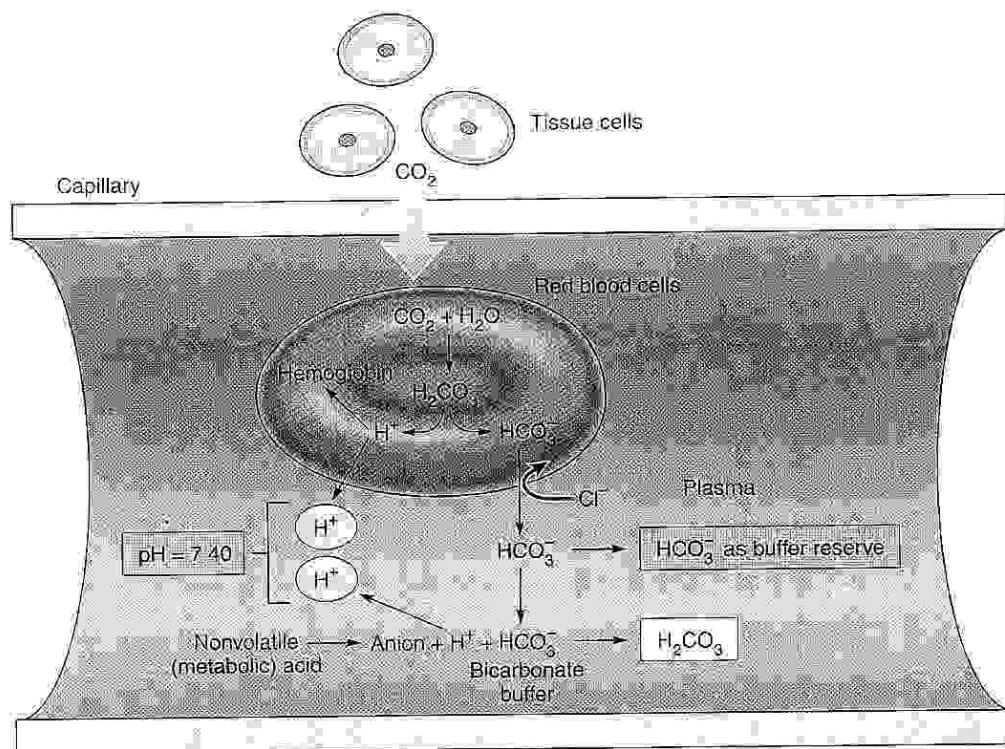

Fig.16.18: Acid-base regulation in the blood by  $\text{HCO}_3^-$ .

Acidosis and alkalosis, mentioned earlier are categorized as respiratory and metabolic components. **Respiratory acidosis** is caused by **hypoventilation**, which results in the rise of plasma  $\text{CO}_2$  concentration. **Metabolic acidosis** results from excess production of nonvolatile acids. **Respiratory alkalosis**, by contrast, results due to **hyperventilation**. Athletes, especially short distance runners, use hyperventilation to transiently build an alkaline pH of the blood, which consequently absorbs excess of  $\text{H}^+$  from lactate, generated in the skeletal muscle due to inadequate oxygen supply during running. Metabolic alkalosis may be caused due to excess  $\text{HCO}_3^-$  or inadequate nonvolatile acids, caused due to vomiting. Vomiting may cause alkalosis through the loss of gastric juice, which is normally absorbed from the intestine into the blood.

#### 16.6. COMMON RESPIRATORY DISORDERS : PREVENTION AND CURE :

The disorders relating to the functioning of lungs are classed as **restrictive** and **obstructive**. In restrictive disorders, the inspiratory vital capacity is reduced to a sub-normal value. The rate of expiratory vital capacity is, however, is normal. In obstructive disorders, by contrast, the vital capacity is usually normal, because the lung tissue is not damaged. The expiration is more difficult due to the obstruction of the airways. The degree of obstruction is measured by **forced expiratory volume (FEV)**. An FEV less than 80% suggests the presence of an obstructive pulmonary disease. Chronic bronchitis, asthma and emphysema are grouped together as **chronic obstructive pulmonary disease (COPD)**. COPD is the fifth leading cause of death in the world. Some common disorders relating to the respiratory system, especially the lungs and the airways are discussed in the underlying section.

##### **Smoking :**

Smoking has both short-term and long-term effects on the respiratory system and its functioning. Nicotine, present in the tobacco, causes constriction of finer bronchioles, increasing resistance to the passage of air. Nicotine also paralyzes the cilia, present along the respiratory tract, which help to remove dirt and mucous, which would otherwise accumulate in the airways. Smoking also irritates the goblet cells and stimulates them to produce excess mucous. The mucous may constrict the airways causing difficulty in breathing. Long-term smoking may lead to several diseases, some of which are discussed in the succeeding sections.

##### 16.6.1. Asthma :

It is a form of difficult and heavy breathing, caused by the spasm of the smooth or involuntary muscle, present in the wall of the airways, especially bronchioles. Contraction of such muscle results in the narrowing down of the bronchioles (**broncho-constriction**). The person experiences difficulty in breathing out than breathing in. Secretion of excess mucous aggravates the situation. This mucous may trap bacteria, which may cause serious infections of the bronchus and bronchioles, known as bronchitis. Difficulty in breathing due to broncho-constriction is compounded by the secretion of **immunoglobulin E (Ig E)** during exercise.

Ig E binds to the mast cell surface and stimulates it to release histamine, which causes inflammation and allergy.

The causes of asthma may be an over-reaction to one of several possible exogenous stimuli and allergy-causing agents (allergens), such as pollen grains, house-hold dust, specific types of food, feathers and particles of cotton. Emotional disturbances may also provoke an asthma attack. Cold, cigarette smoke, polluted air from vehicular exhaust also may cause asthma. Thus, the cause of asthma is not similar in all patients. The lung of the affected people has an increased number of mast cells and eosinophils. These cells are stimulated to produce histamine and leukotrienes, which produce hypersensitivity or allergy along the airways and alveoli.

Asthma is treated with glucocorticoid drugs, which inhibit inflammation and allergy. Anti-leukotriene drugs are also used to suppress the inflammatory response. Epinephrine is frequently used as an inhaled bronchodilator drug to relieve the symptoms of asthma. However, this drug binds to adrenergic receptors. Based on this finding, a drug, named as terbutaline is formulated, which specifically bind to the adrenergic receptors, present on the cells of the bronchioles and effect broncho-dilation.

Asthma can be prevented by avoiding exposure to sensitive allergens.

#### **Bronchitis :**

It is the inflammation of the lining of the airways and may be **chronic** or **acute**. Chronic bronchitis has a gradual onset and is of a long duration. Acute bronchitis, by contrast, flares up suddenly and dies down in a short period of time. It may be a side effect of an infection, like common cold.

Chronic bronchitis is a much more serious problem that may be caused and aggravated by smoking or inhaling polluted air. Excess mucous secretion in bronchi and bronchioles causes obstruction.

#### **16.6.2. Emphysema :**

Emphysema is a chronic lung disease, characterized by a damage to the air sacs (alveoli) in the lungs. The lung tissue supporting the alveoli loses its elasticity and the capillaries feeding the alveoli are destroyed. The air sacs are unable to deflate completely resulting in the trapping of the expired air inside. The lung cannot be renewed with fresh air thus impairing the exchange of  $O_2$  and  $CO_2$ . This leads to the expression of symptoms such as, shortness of breath on exertion; hyperventilation and expanded chest; chronic cough and limited ability to exercise. These conditions together constitute emphysema. Emphysema and chronic bronchitis frequently co-exist together to comprise **chronic obstructive pulmonary disease**. The damage to the lung tissue may occur due to : (a) exposure to toxic chemicals; (b) long term exposure to tobacco smoke and (c) **alpha-1-antitrypsin** deficiency. The first two causes are extrinsic, while the third is intrinsic. Cigarette smoke is the most common cause of emphysema (80-90%). It stimulates the alveolar macrophages to secrete trypsin,

which digests and destroys the lining of the lung. In the rest, the disease results due to the deficiency of a protease inhibitor, alpha-1-antitrypsin. Alpha-1-antitrypsin is a protease, secreted by white blood cells, especially, neutrophils. This enzyme inhibits trypsin, secreted by alveolar macrophages. The enzyme is encoded by a gene, located on **chromosome 14**. Smoking must be avoided to prevent this disease.

#### **Cystic fibrosis (CF) :**

CF is an inherited disorder affecting many different parts of the body, including the lungs. It is characterized by chronic cough with thick mucus in the lungs. These symptoms lead to several secondary symptoms such as blockage of the airways of the lungs and infection leading to inflammation and pneumonia. The disease is caused by a mutation in the **cystic fibrosis transmembrane conductance regulator (CFTR) gene**, located on **chromosome 7**. The normal gene encodes a trans-membrane CFTR protein. It is a chloride channel that regulates the movement of sodium chloride across the plasma membrane and thus regulates the concentration of salts in the extra-cellular secretions. The mutant gene encodes a defective chloride channel, which fails to regulate the flux of chloride ions in particular. The result is that the extra-cellular secretions become thicker and more viscous. This thicker and sticky mucus clogs the the airways of the lungs leading to infection and inflammation, impaired function and finally failure. **Francis Collins** and his coworkers have successfully mapped and cloned the gene. The mutant gene has been replaced by a cloned gene in gene therapy trials.

#### **Pulmonary fibrosis :**

Under certain conditions, not fully understood, the damage to the lung tissue leads to pulmonary fibrosis instead of emphysema. The normal structure of the lungs is disrupted by the accumulation of fibrous connective tissue proteins. It can also result due to an inhalation of particles, less than 6  $\mu\text{m}$  in size that accumulates in the respiratory zone of the lung. **Anthracois** or **black lung** is a type of pulmonary fibrosis, produced by the inhalation of carbon particles from the coal dust.

#### **Lung cancer :**

It is one of the most common forms of cancer in men and is the third most common cause of death in developed countries after coronary heart disease and heart strokes. Cancer is caused by uncontrolled mitotic cell divisions forming tumors. Sometimes these cells breakaway from the original site and invade other tissues of the body to develop secondary tumors. Lung cancer usually starts in the epithelium of the bronchioles and then spreads throughout the lungs. It is caused exclusively by smoking (99.7%). Tobacco smoke contains a chemical like benzpyrene, which acts as a carcinogen and causes cancer. So smoking must be avoided to prevent this disease.

**Infectious Diseases of the respiratory system :**

- (i) **Tuberculosis (TB)** : caused by the bacterium *Mycobacterium tuberculosis*, a rod-shaped bacterium.
- (ii) **Diphtheria** : caused by the bacterium *Corynebacterium diphtheria*, usually affecting children.
- (iii) **Whooping cough (Pertussis)** : Caused by the bacterium *Bordetella pertussis*, affecting children.
- (iv) **Pneumonia** : Caused by the diplococcus bacterium *Diplococcus pneumoniae*. In some cases, this is also caused by fungi, protozoa and viruses. The alveoli are inflamed. Lymph, mucus accumulate in the alveoli and bronchioles, adversely affecting the efficiency of the lungs.

**16.6.3. Occupational Respiratory Disorders :**

Workers in environments in several industries are often exposed to potential harmful chemicals, gases, dust particles and aerosols. **Silicosis** and **asbestosis** result from a chronic exposure to fine particles of silica, asbestos and cement which when inhaled tend to settle down on the walls of the airways and the alveoli, thereby causing irritation and blockage. This affects the respiratory efficiency and causes breathlessness.

**16.6.4. Carbon monoxide poisoning :**

The affinity of deoxyhaemoglobin (containing  $\text{Fe}^{2+}$ ) for carbon monoxide is about 250 times greater than that of oxygen. Thus, haemoglobin quickly takes up any available carbon monoxide in preference to oxygen to form a stable compound called **carbon monoxyhaemoglobin** or **carboxyhaemoglobin**. If it happens, haemoglobin is not available to take up oxygen and tissues and vital organs like the heart and brain starve without oxygen. This results in **carbon monoxide poisoning** and the body collapses unless exposure to carbon monoxide is quickly stopped and pure oxygen and a small amount of  $\text{CO}_2$  is inhaled. Carbon dioxide stimulates the respiratory centre in the medulla and breathing is made faster to flush out the carbon monoxide from the lungs. Carbon monoxide is present in the exhaust of the automobiles and tobacco smoke.

Some drugs and oxidizing agents oxidize the normal ferrous valency state of iron ( $\text{Fe}^{2+}$ ) of haemoglobin to ferric state ( $\text{Fe}^{3+}$ ). This haemoglobin is known as **methaemoglobin**. Some oxidation of haemoglobin to methaemoglobin occurs normally. However, an erythrocyte enzyme converts it back into normal haemoglobin. Congenital absence of this enzyme causes the hereditary disease, **methaemoglobinemia**.

---

**SAMPLE QUESTIONS****GROUP - A****(Objective-type Questions)****1. Choose the correct answer :**

- (i) When does the frog respire by the skin ?  
(a) While in water (c) During hibernation  
(b) While on land (d) During all the times
- (ii) The exchange of gases in the lung alveoli occurs by  
(a) Active transport (c) Diffusion  
(b) Passive transport (d) None of the above
- (iii) The amount oxygen taken in and carbon dioxide released during quiet breathing is  
(a) 500 ml. (c) 3000 ml.  
(b) 1000 ml. (d) 5000 ml.
- (iv) If the  $\text{CO}_2$  concentration in the blood increases, the breathing will  
(a) Increase (c) Stop  
(b) Decrease (d) Remain unaffected
- (v) If a tissue is having inadequate supply of oxygen, the condition is called  
(a) Hypoxia (c) Asphyxia  
(b) Anoxia (d) Anaemia
- (vi) The respiratory centre that regulates breathing is located in which part of the brain ?  
(a) Cerebral hemispher (c) Hypothalamus  
(b) Diencephalon (d) Medulla oblongata
- (vii) The quantity of 500 ml. of air during quiet breathing in man refers to the  
(a) Residual volume (c) Vital capacity  
(b) Tidal volume (d) Dead space air
- (viii) Which structure in pharynx prevents the entry of food into the respiratory tract ?  
(a) Larynx (c) Glottis  
(b) Gullet (d) Epiglottis
- (ix) Which of the following prevents the collapse of the trachea ?  
(a) Diaphragm (c) Muscles in the wall  
(b) Cartilaginous rings (d) None of the above
- (x) The enzyme involved in  $\text{CO}_2$  transport by blood is  
(a) Carboxylase (c) Carbonic anhydrase  
(b) Carboxykinase (d) None
- (xi) What is the rate of breathing in a normal healthy man at rest ?  
(a) 15-20 times/min (c) 20-30 times/min  
(b) 10-15 times/min (d) 40-50 times/min



**2. Answer each of the following in one or two words :**

- (i) What type of respiration is seen in the frog during hibernation ?
- (ii) What type of respiration is seen in endoparasites like the liver fluke and the filarial worm ?
- (iii) What is the mode of respiration of the frog, while it is in water ?
- (iv) What type of respiration is seen in insects ?
- (v) In which part of the body is a schneiderian membrane located ?
- (vi) What is the major form of oxygen transport by the blood ?
- (vii) What is the major form of  $\text{CO}_2$  transport by the blood ?
- (viii) Name the organ in man, which produces speech ?
- (ix) What is the prosthetic group present in the haemoglobin molecule ?
- (x) What is the respiratory pigment present in arthropods like the prawn ?
- (xi) Which muscles in the thoracic wall bring about inspiration ?
- (xii) What is the muscular partition that divides the thoracic and abdominal cavities ?
- (xiii) In which part of the mammalian brain the respiratory centre is located ?
- (xiv) How many pair of spiracles are present in cockroach ?
- (xv) What type of gill is found in cartilaginous fish ?
- (xvi) What type of gill is found in the bony fish ?
- (xvii) What is the oxygen carrying capacity of the human haemoglobin ?

**GROUP - B****(Short Answer-type Questions)****1. Differentiate between :**

- (i) Anabolism and Catabolism
- (ii) Anaerobic respiration and Aerobic respiration
- (iii) Cutaneous respiration and Pulmonary respiration
- (iv) Inspiration and Expiration
- (v) External intercostal muscle and Internal intercostal muscle
- (vi) Quiet breathing and Forced breathing
- (vii) Tracheal respiration and Branchial respiration
- (viii) Tidal volume and Vital capacity
- (ix) Myoglobin and Haemoglobin.
- (x) Deoxyhaemoglobin and Oxyhaemoglobin
- (xi) Carbaminohaemoglobin and Carboxyhaemoglobin.
- (xii) Substrate level phosphorylation and Oxidative phosphorylation
- (xiii) Asthma and Emphysema.

**2. Write brief notes on the following (within 50 words each) :**

- (i) Cutaneous respiration
- (ii) Disadvantages of tracheal respiration
- (iii) Haldane effect
- (iv) Bohr effect
- (v) Chloride shift / Hamburger phenomenon
- (vi) Residual volume
- (vii) Vital capacity
- (viii) Role of diaphragm in respiration
- (ix) Advantages and disadvantages of cutaneous respiration
- (x) Counter current flow in gill respiration
- (xi) Structure and functions of larynx
- (xii) Bronchial tree
- (xiii) Control of ventilation
- (xiv) Hering– Breur reflex
- (xv) Structure of haemoglobin
- (xvi) Myoglobin
- (xvii) Role of haemoglobin as a buffer
- (xviii) Carbon monoxide poisoning

**GROUP - C****(Long Answer-type Questions)**

1. Describe the mechanism of breathing and its regulation in human.
2. Describe the transport of respiratory gases in the blood of human.
3. Give an account of gaseous exchanges both at the tissues and alveolar levels.
4. Draw a neat labeled diagram of the respiratory organs of human. (Description is not required)



The major constituent in the body of all living organisms is water. It is present in the form of different types of body fluids, which fall under two main categories: (1) **intracellular fluid**, containing 55% of the total body water and (2) **extracellular fluid**, containing 45% of the total body water. Intracellular fluid is present in the form of protoplasm in the cells, while extracellular fluid is present in the extracellular spaces. All body fluids contain water as the major constituent and dissolved solutes. The solutes are both organic and inorganic. There is a continuous exchange of water and all kinds of solutes between the internal and external environments. This creates disequilibrium in the homeostasis. Therefore, a continuous circulation of body fluids is essential for maintaining homeostasis in the body. Majority of multicellular animals possess defined circulatory systems, each with a pumping organ, the heart and walled vessels for circulation of the body fluid throughout the body. However, a few possess circulatory systems without walled blood vessels. This type of circulatory system has been designated as **open type**. The other type with walled vessels is designated as **closed type**. The circulatory system performs the following functions:

**1. Transportation :**

- (i) **Transport of nutrients :** The digested food is carried from the alimentary canal to the cells and tissues for metabolism and / or storage.
- (ii) **Transport of respiratory gases :** Respiratory gases, such as oxygen is transported to the tissues for cellular oxidation and carbon dioxide is transported from the site of cellular oxidation for elimination from the body.
- (iii) **Transport of excretory wastes:** Nitrogenous excretory waste materials generated through catabolism of proteins and nucleic acids are transported from the site of their formation for elimination from the body.

**2. Regulation :**

- (i) **Hormonal regulation :** Hormones secreted from endocrine glands are carried by the circulating fluid, such as the blood to the target tissues for action.
- (ii) **Temperature regulation :** The circulating body fluid functions as a medium for even distribution of temperature throughout the body.

### 3. Protection :

- (i) **Clotting** : The body fluid, especially blood of vertebrates possesses an intrinsic ability to prevent its loss by forming a plug by a clotting mechanism.
- (ii) **Immunity** : Blood of vertebrates is the bearer of cells (leucocytes) and molecules (antibodies), which protect the body from invasive organisms and substances.

#### Different types of body fluids :

- 1. **Intracellular fluid : Protoplasm**
- 2. **Extracellular fluid :**
  - (i) **Plasma**
  - (ii) **Interstitial fluid and lymph**
  - (iii) **Fluid in bones**
  - (iv) **Fluid in cartilage**
  - (v) **Trans cellular fluid**
    - (a) Cerebrospinal fluid
    - (b) Intra-ocular fluid,
    - (c) Digestive juice,
    - (d) Serous fluid (intra pleural fluid, pericardial fluid and peritoneal fluid)
    - (e) Synovial fluid in joints
    - (f) Fluid in urinary tract.

Circulatory system of a vertebrate, especially of human has two components: (1) **cardio-vascular system**, consisting of heart; blood vessels; and a circulating fluid, the blood and (2) **lymphatic system**, consisting of lymphoid tissues, lymph vessels and lymph.

#### 17.1. COMPOSITION OF BLOOD (Fig. 17.1) :

Blood is a special type of connective tissue, consisting of a cellular part, constituted by the **formed elements** or the **corpuscles**, suspended in a fluid part, the **plasma**. The plasma is the intercellular substance or matrix, which does not contain any fiber common to all other types of connective tissues. When a sample of blood is centrifuged, the formed elements settle at the bottom as sediment, leaving plasma at the top. More than 99% of the cells are erythrocytes, while leucocytes and platelets together account for very negligible percentages. The erythrocytes constitute approximately 45% and 42% of the total blood volume in men and women, respectively. This is known as the **hematocrit**. The plasma

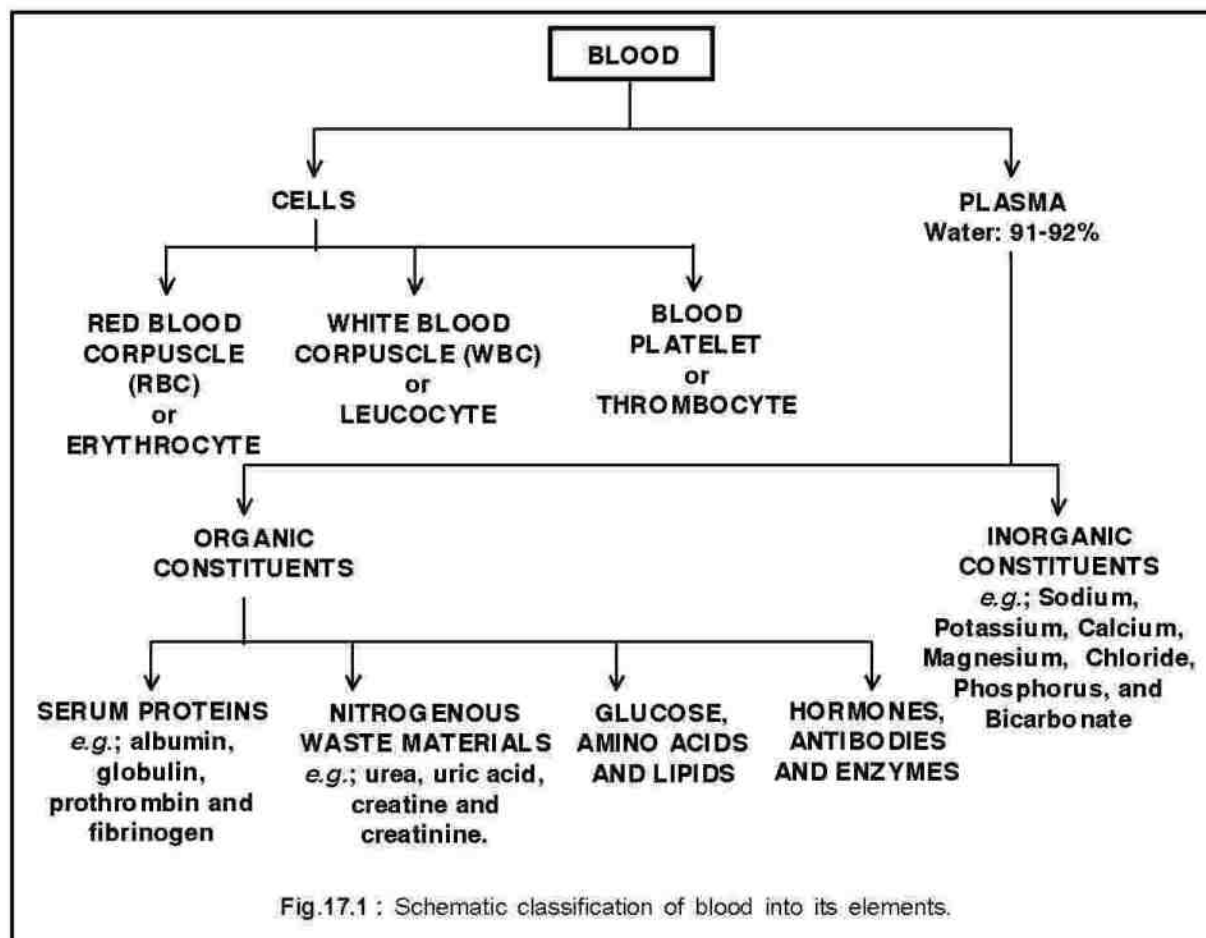

accounts for the remaining 55%. The total blood volume of an average person is approximately 5.5 L. If the hematocrit is taken as 45%, then : Total erythrocyte volume =  $0.45 \times 5.5 \text{ L} = 2.5 \text{ L}$

Therefore, The plasma volume =  $5.5 \text{ L} - 2.5 \text{ L} = 3.0 \text{ L}$

### 17.1.1. Plasma :

The plasma is a straw yellow coloured watery fluid containing many dissolved solutes. The water makes up 91-92% of the plasma. The rest are solutes, which are classed as: (1) organic (colloids) and (2) inorganic (crystalloids). The organic constituents include 7-9% plasma proteins, such as albumins, globulins, prothrombin and fibrinogen. Albumins are produced by the liver and these help maintain the blood volume and pressure. Globulins are of three types : a, b and g. The a and b globulins are produced by the liver and help in transporting lipids and fat soluble vitamins. g globulins are produced by B-lymphocytes, which function as antibodies. Other proteins of the plasma are prothrombin and fibrinogen, which help in blood clotting or coagulation. Other organic constituents of the plasma are nutrients, such as glucose, amino acids and lipids; nitrogenous excretory wastes, such as urea, uric acid, creatine and creatinine; and hormones and enzymes. The straw yellow colour

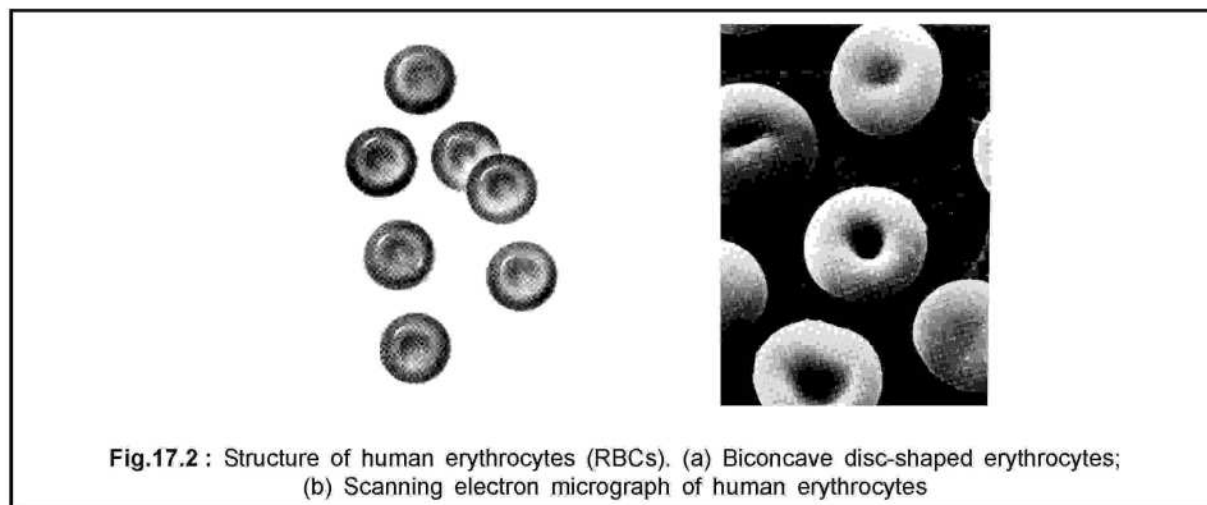

**Fig.17.2 :** Structure of human erythrocytes (RBCs). (a) Biconcave disc-shaped erythrocytes; (b) Scanning electron micrograph of human erythrocytes

of the plasma is due to the presence of substances, such as **bilirubin** and **carotene**. The inorganic constituents are ions of sodium, potassium, calcium, magnesium, phosphate and bicarbonate. The plasma that has been in equilibrium with RBCs, is slightly alkaline with a pH in the range of 7.35-7.45. A constant plasma volume is essential for normal functioning of the body. If the body loses water, the plasma becomes concentrated. This is detected by the osmoreceptors in the hypothalamus, resulting in the release of antidiuretic hormone (ADH) from the posterior pituitary. This hormone increases thirst and consequently intake of water and promotes water retention by the kidneys. This is a regulatory mechanism to maintain homeostasis of the plasma volume. Following the coagulation of the blood, a clear watery fluid, known as **serum**, oozes out from the wound. The serum is that part of plasma without fibrinogen and clotting factors II, V and VIII, which have been removed during the clotting reaction. The schematic classification of the blood into its constituents is presented in Fig.17.2.

#### 17.1.2. Formed elements (Cells or Corpuscles) :

The blood has three types of formed elements or cells: erythrocytes or red blood corpuscles (RBCs); leucocytes or white blood corpuscles (WBCs); and thrombocytes or platelets.

**(a) Erythrocytes (RBCs) :** Erythrocytes of human are biconcave disc-like cells without nuclei and mitochondria (Fig.17.2). They lose their nuclei before entering the circulation. Due to the absence of mitochondria, they obtain energy by anaerobic respiration. An erythrocyte measures about 7  $\mu\text{m}$  in diameter and 2.0  $\mu\text{m}$  in thickness (1  $\mu\text{m}$  =  $10^{-6}$  m =  $10^{-3}$  mm). The average number of erythrocytes is 5.5 millions/ $\mu\text{L}$  (1  $\mu\text{L}$  = 1  $\text{mm}^3$ ) in a healthy adult man and 4.5 millions/ $\mu\text{L}$  in a woman. It survives in the circulation for an average of 120 days.

When suspended in a suitable medium, the erythrocytes pile up one above the other forming **rouleaux**. The erythrocytes maintain their normal shapes as long as they are

suspended in an isotonic medium. When the medium becomes hypotonic, the cells absorb water by **endo-osmosis** and swell up and ultimately burst releasing the haemoglobin into the medium [Fig. 17.3 (a)]. This phenomenon is known as **haemolysis**. Haemolysis results in the formation of ruptured erythrocyte plasma membranes, known as **red cell ghosts**. Alternately, if the erythrocytes are placed in a hypertonic solution, there is a loss of water from the cells due to **exo-osmosis** and consequently, the cells shrink developing irregularities at their surfaces. This phenomenon is known as **crenation** and the shrunken erythrocytes are known as **echinocytes** [Fig. 17.3(b)].

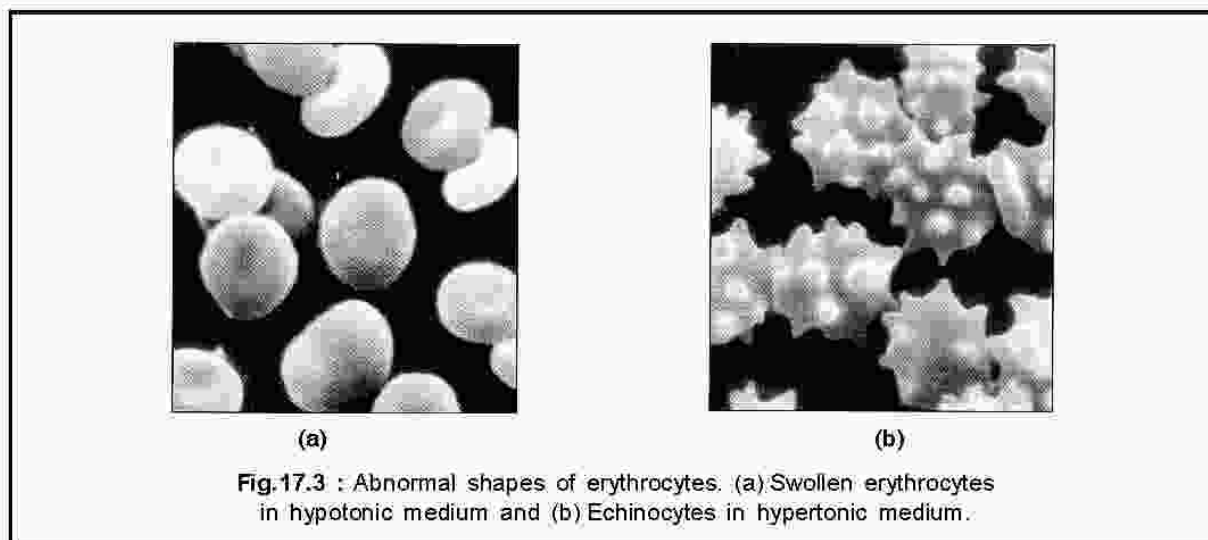

RBCs are so named due to the presence of a red coloured respiratory pigment, known as **haemoglobin**. Each erythrocyte contains 29 pg (pico gram;  $1 \text{ pg} = 10^{-12} \text{g}$ ) of haemoglobin and thus, all the erythrocytes will contain 900 g of haemoglobin. The haemoglobin content of the blood must be maintained at a normal for normal respiratory function. Following senescence and death of RBCs, the heme iron is recycled in the liver and travels in the blood to the bone marrow, conjugated to a protein carrier, **transferrin**. Haemoglobin is a **conjugate protein** *i.e.*, a protein part, known as **globin** is conjugated to a non-protein part or prosthetic group, known as **heme**. The globin consists of two each of  $\alpha$  and  $\beta$  polypeptides. The heme consists of four sub-units. Each sub-unit contains a porphyrin or tetra-pyrrole ring. There is an iron atom in ferrous valency state ( $\text{Fe}^{2+}$ ) at the centre of the porphyrin. It is the element, iron that imparts a red colour to the haemoglobin. The  $\text{Fe}^{2+}$  is attached by four co-ordinate bonds to the four pyrrole rings and by two more co-ordinate bonds to the globin ( $\alpha$  or  $\beta$ ) chain (Fig.17.4). One of the co-ordinate bonds, by which it is attached to the globin chain, is displaced by molecular oxygen and consequently, oxyhaemoglobin is formed. Due to its oxygen carrying function, haemoglobin is known as a **respiratory pigment**. The haemoglobin, containing two each of  $\alpha$  and  $\beta$  globin chains is termed as **adult haemoglobin (haemoglobin A)**. The  $\beta$  globin chain in 25% of adult haemoglobin is substituted by  $\delta$  globin

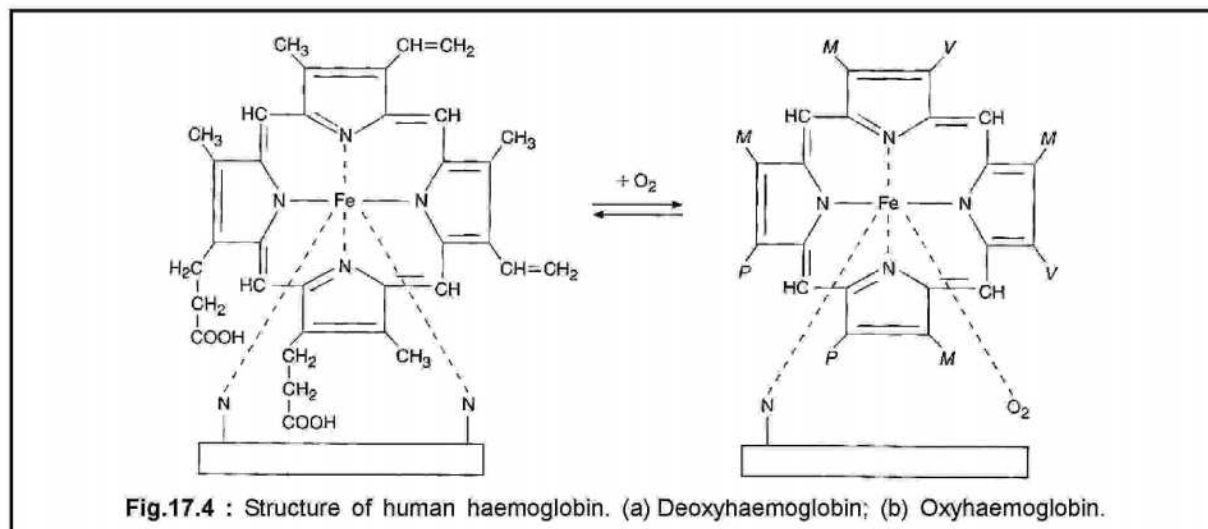

### Erythrocyte abnormality :

A normal number of erythrocytes is required for normal functioning. However, under situations, the number increases or decreases. An increase in number gives rise to a condition, known as, **polycythemia**, while a decrease leads to a fall in the haemoglobin content of the blood, a condition, known as **anemia**. Anemia is of several types :

**Aplastic anemia** : Destruction of bone marrow stem cells by chemicals, such as benzene, arsenic and radiation.

**Microcytic anemia** : The erythrocytes remain smaller and hence, contain less haemoglobin than normal.

**Haemolytic anemia** : Excessive destruction of erythrocytes.

**Pernicious anemia** : Sub-normal absorption of vitamin B<sub>12</sub> (cyanocobalamine) from the intestine due to a lack of intestinal protein, intrinsic factor, which assist in its absorption. Vitamin B<sub>12</sub> helps in erythrocyte formation.

**Hereditary spherocytosis** : Absence of an erythrocyte cytoskeletal protein, ankyrin, leads to a spherical shape of erythrocytes, instead of the default biconcave shape. Such spherical erythrocytes squeeze and rupture spontaneously, leading to a loss of haemoglobin, a condition known as **hereditary hemolytic anemia**. It is an autosomal recessive disorder.

**Sickle cell anemia** : The haemoglobin is abnormal due to an amino acid substitution in the b-globin chain. The erythrocytes remain sickle shaped and the haemoglobin has a reduced oxygen carrying capacity. It is an autosomal recessive disorder.



chain. In fetus, however, the  $\beta$  globin chains are substituted by  $\gamma$  chains. This haemoglobin has been referred to as **fetal haemoglobin (haemoglobin F)**.

Each sub-unit of haemoglobin molecule binds to a molecule of oxygen. Thus, a complete deoxyhaemoglobin molecule binds to four molecules of oxygen at saturation. However, all the four molecules do not bind at once. In the first step, one molecule binds and this facilitates the binding of the second and so on. This type of binding is known as **co-operative or allosteric binding**.

**(b) Leucocytes (WBCs) :** Leucocytes (WBCs) are nucleated blood cells of variable shapes and sizes. These are so named because of the absence of pigments. The number

*There are two types of inherited disorders of haemoglobin production in human: **haemoglobinopathies** and **thalasemias**.*

*In **haemoglobinopathies**, abnormal polypeptides are produced. Mutant genes encode abnormal polypeptides, which make the haemoglobin abnormal. Many abnormal haemoglobins have been described in human. These are identified by alphabets, such as C, E, I, J, S, etc.*

*In **thalasemias**, the polypeptides are normal. However, there is a decreased synthesis of  $\alpha$ - or  $\beta$ -globin. Accordingly, the disorder is either named as  **$\alpha$ -thalasemia** or  **$\beta$ -thalasemia**.*

of leucocytes in a healthy human adult is in the range of 4,000-10,000/ $\mu$ L of blood. Under special pathological conditions, the number varies considerably. The increase in the number above normal is known as **leucocytosis**, while a decrease below normal is **leucopenia**. In an acute condition, known as **leukemia**, there is an uncontrolled release of a large number of immature leucocytes into the circulation.

Leucocytes are primarily classified as **granulocytes** or **polymorphonuclear leucocytes (PMNs)** and **agranulocytes** based on the presence or absence of characteristic granules in the cytoplasm. Based on the staining properties of the cytoplasmic granules, the granulocytes are of three types : **neutrophils**, **eosinophils** or **acidophils** and **basophils**. Agranulocytes do not contain any granule in their cytoplasm. They are of two types: **lymphocytes** and **monocytes**. Each type of leucocyte has a specific percentage of occurrence in the blood (Table 17.1). Any serious deviation of the percentages points towards a pathological condition.

**(i) Neutrophil [Fig.17.5 (a)] :** The name is derived from the neutral staining properties of the cytoplasmic granules. It is characterized by the presence of a **multi-lobed nucleus**. In human female, the nucleus is seen to possess an additional smaller lobe at one end. This lobe is known as **drum stick**. The drum stick stains relatively darker and is considered as having the inactivated X chromosome (Barr Body). Neutrophils have a very short life span.

They circulate in the blood for approximately 10 hr and then enter into the connective tissue, where they live for another 2-3 days. These are attracted by chemotactic factors, secreted by bacteria at the site of infection. They leave the circulation by piercing through two adjacent endothelial cells of the capillary and enter into the connective tissue harbouring bacteria. This phenomenon is known as **diapedesis** or **extravasation**. They, then, turn into **phagocytes** and engulf and digest the bacterial cells.

(ii) **Eosinophil (Acidophil)** [Fig.17.5 (b)] : The name of this granulocyte is derived from the acidic staining property of the cytoplasmic granules. The granules preferably stain with eosin, an acidic dye. The nucleus is bilobed. They have a short life span. They circulate

**Table - 17.1**  
**Number range and relative percentages of different corpuscles**

Cell	Cells / $\mu\text{L}$	Approximate Normal Range/ $\mu\text{L}$	%
Erythrocytes (Male)	$5.5 \times 10^6$	—	—
Erythrocytes (Female)	$4.5 \times 10^6$	—	—
Leucocytes	8,000	4,000-10,000	—
<b>Granulocytes</b>			
Neutrophils	5,400	3,000-6,000	50-70
Eosinophils	275	150-300	1-4
Basophils	35	0-100	0.4
<b>Agranulocytes</b>			
Lymphocytes	2750	1,500-4,000	20-40
Monocytes	540	300-600	2-8
Platelets	300,000	200,000-500,000	—

in the blood for around 10 hr and then migrate to the connective tissue by the same phenomenon of diapedesis and stay there for up to 10 days. Eosinophils are phagocytic cells having an affinity for antigen-antibody complexes, formed at the site of inflammation. They also migrate to the site of parasitic infection and specifically kill, engulf and digest helminth larvae. They are, especially abundant in the mucosa of the gastro-intestinal, respiratory and urinary tracts, where they defend against parasites.

(iii) **Basophil** [Fig.17.5 (c)] : This granulocyte has cytoplasmic granules having basic staining property. The nucleus is bilobed. They have a short life span and a negligible percentage in the blood. Their function is similar to that of a **mast cell**. Basophils store **histamine** and **heparin**. Release of histamine causes inflammation (allergic reaction) and vascular changes, which lead to fluid leakage from blood vessels. This causes severe **hypersensitivity** responses and **anaphylaxis**.

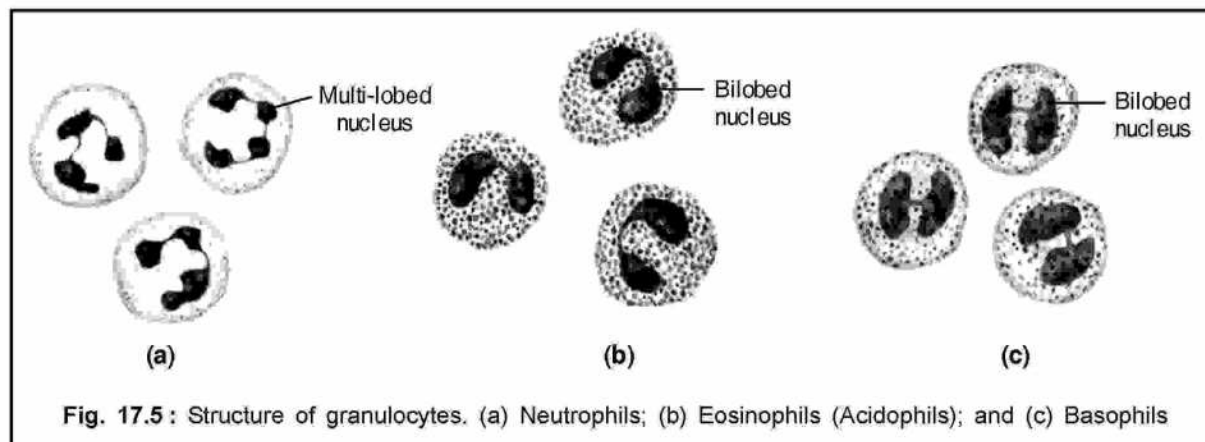

Fig. 17.5 : Structure of granulocytes. (a) Neutrophils; (b) Eosinophils (Acidophils); and (c) Basophils

(iv) **Lymphocyte [Fig.17.6 (a)]** : Lymphocytes have variable life spans, ranging from several days to months. A lymphocyte is characterized by the presence of an **indented nucleus**. They play a key role in the immune response of the body. Lymphocytes mature and become immunologically competent cells in the thymus and Bursa of Fabricius or its analogous structures. Thymus maturing lymphocytes are known as T-lymphocytes, while lymphocytes maturing in the Bursa of Fabricius are known as B-lymphocytes. T-lymphocytes act as killer or cytotoxic cells, killing pathogenic microorganisms and other alien cells entering into the body. They also help B-lymphocytes mature into antibody secreting plasma cells.

(v) **Monocytes [Fig.17.6 (b)]** : There is no cytoplasmic granule. **The nucleus is horse shoe shaped**. They live in the blood circulation for 2-3 days. Then they move into the connective tissue, where they live for a few months. In the connective tissue, monocytes become **phagocytes**. At the site of infection, monocytes differentiate as **tissue macrophages**, which then destroy bacteria, foreign particles and cellular debris.

(c) **Thrombocytes (Platelets)** : Thrombocytes or platelets are small anucleate oval or disc shaped granulated bodies, measuring 2-4  $\mu\text{m}$  in diameter. These are pinched off from a giant cell in the bone marrow, known as **megakaryocyte**. Thrombocytes are second most numerous among the formed elements of the blood. The number ranges from 200,000-

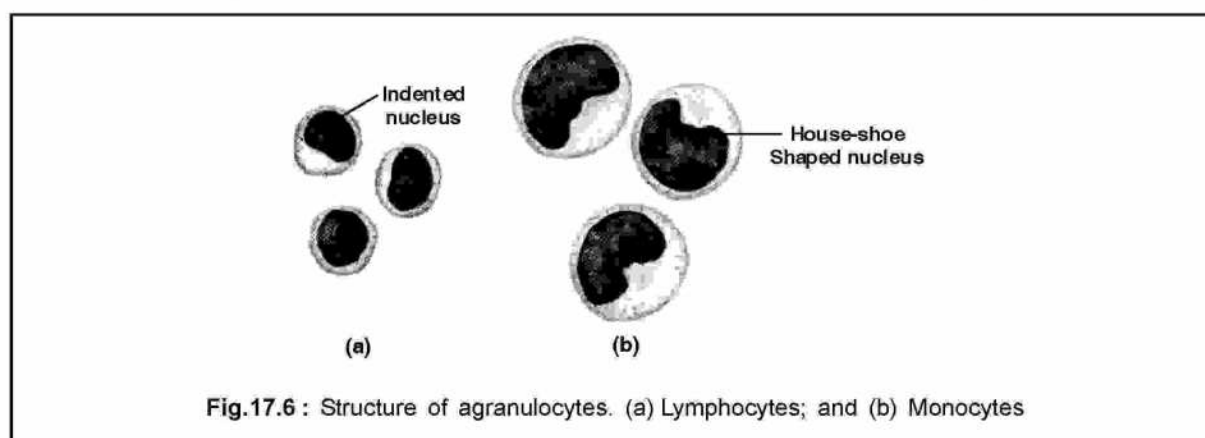

Fig.17.6 : Structure of agranulocytes. (a) Lymphocytes; and (b) Monocytes

500,000/ $\mu$ L of circulating blood. The life span is about 10 days. Each platelet has a ring of microtubules around the periphery. The cytoplasm is granular containing actin, myosin, glycogen, lysosomes and two types of granules. Some granules contain blood clotting factors and a growth factor, known as **platelet derived growth factor (PDGF)**. PDGF promotes wound healing and mitotic divisions in the smooth muscle of the blood vessels. Platelets play a very important role in blood clotting. They contain an essential enzyme, **thromboplastin** that is essential in initiating the blood clotting cascade, ending in the formation of **fibrin mesh**. More than the normal number of platelets (thrombocytes) causes a pathological condition, known as **thrombocytosis**. Deficiency of platelets is known as **thrombocytopenia**, which leads to prolonged bleeding, following a minor injury.

### **Hematopoiesis :**

Blood cells are continuously formed by a process known as **hematopoiesis** (also called **hemopoiesis**). The stem (undifferentiated) cells, which differentiate as blood cells originate in the yolk sac and then migrate to the liver. Thus, liver functions as the hematopoietic organ of the fetus.. These stem cells then migrate to the bone marrow. The liver ceases to function as the hematopoietic organ soon after birth. Thereafter, the bone marrow manufactures different kinds of blood cells till death.

Erythropoiesis refers to the formation of erythrocytes, while leucopoiesis to leucocytes. Similarly, thrombopoiesis refers to the formation of thrombocytes.

All blood cells descend from a single population of bone marrow stem cells, known as **pluripotent stem cells**. Thus stem cells are uncommitted cells, which divide and redivide to form new stem cells or become committed to a specific developmental pathway, leading to the formation of a particular type of blood cell. The first commitment is **dichotomous i.e.**, some stem cells are committed to becoming **lymphoid stem cells** and others **myeloid stem cells**. The lymphoid stem cells differentiate as lymphocytes, while the myeloid stem cells as the rest of the blood cells. At some point, the myeloid stem cells become committed to differentiate along one pathway, giving rise to a particular myeloid cell type.

The commitment is believed to be effected by several growth factors, collective called **hematopoietic growth factors**. These factors fall under four classes : **erythropoietin**, **colony stimulating factors**, **interleukins** and **thrombopoietin**. As the stem cells proliferate and differentiate, they express specific membrane receptors for growth factors. A specific growth factor binds to its receptor and thus stimulates the cell to differentiate along a specific line. The earliest cells, which can be distinguished under a microscope are the **erythroblasts** (become erythrocytes); **myeloblasts** (become granular leucocytes); **lymphoblasts** (become lymphocytes);and **monoblasts** (become monocytes).

*Continued...*

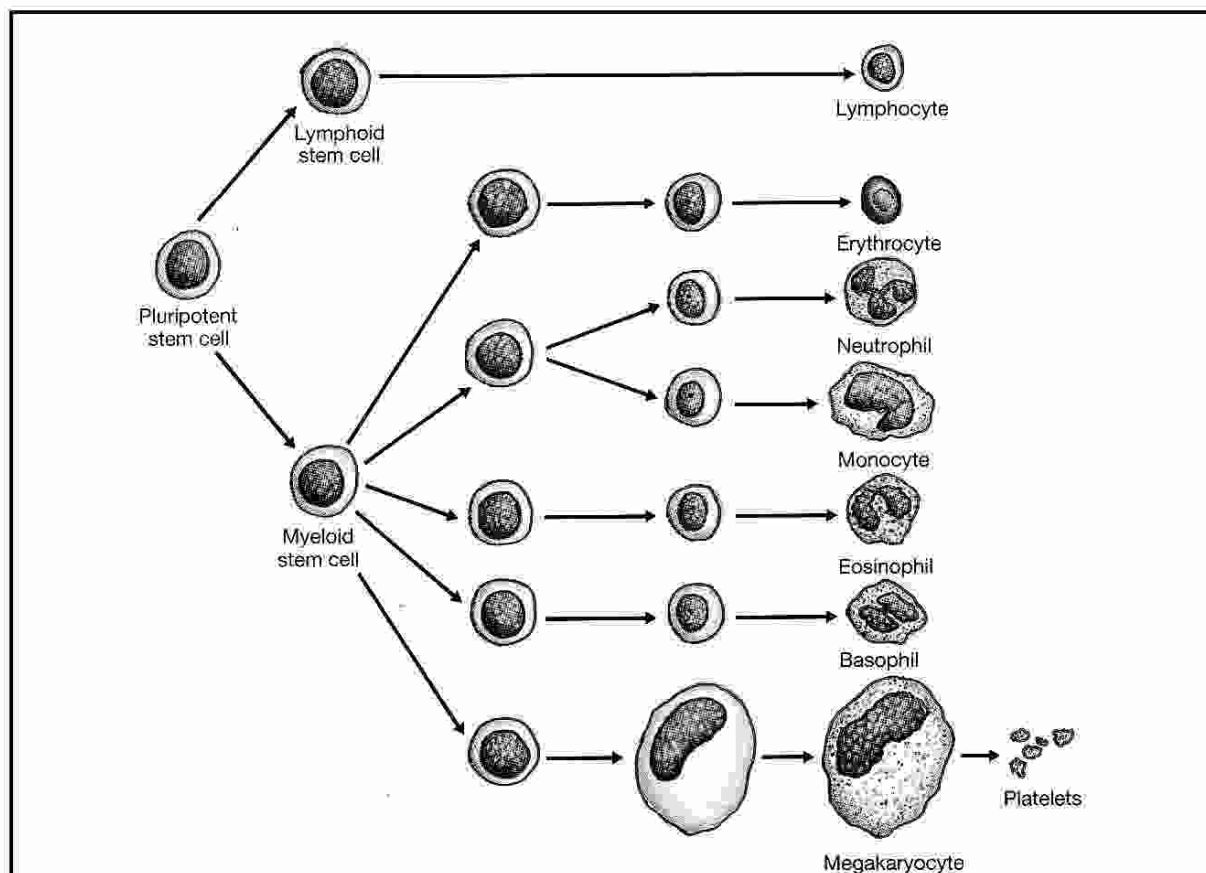

Haematopoiesis (haemopoiesis) of the formed elements (blood cells) in human.

Erythropoiesis is an extremely active process. It is estimated that about 2.5 million erythrocytes are produced every second in order to replenish the worn out and destroyed erythrocytes by the spleen and liver. The life span of an erythrocyte is 120 days. Erythropoiesis is regulated by the hormone **erythropoietin**, secreted by the kidney. The erythropoietin gene has been cloned and expressed by recombinant DNA technology and erythropoietin has been commercially synthesized. It is now commercially available for the treatment of anemia.

The formation of leucocytes is stimulated by biochemical agents, called **cytokines**. These cytokines fall under two classes: colony stimulating factors, such as **granulocyte colony stimulating factor (G-CSF)** and **granulocyte-macrophage colony stimulating factors (GM-CSF)**; and **interleukins (IL)**.

A specific cytokine, called **thrombopoietin** has also been identified. It stimulates a megakaryocyte to form a large number of platelets. This cytokine has commercially been prepared by recombinant DNA technology. It has been used to treat thrombocytopenia (low platelet count).

**Bone marrow transplantation :**

*In some people, the bone marrow stem cells fail to form the normal number of blood cells, which leads to serious consequences like anemia, leukemia and immunodeficiencies. In these situations, bone marrow transplantation is the effective treatment. It involves the aspiration of marrow from the iliac crest and separation of the hematopoietic stem cells. Stem cells are also isolated from the peripheral blood of the donor, injected with G-CSF and GM-CSF. Another source of the stem cells is the umbilical cord of a neonatal baby. These cells are stored and used as and when necessary.*

*The stem cells are implanted into the bone marrow and necessary stimuli are given for their appropriate differentiation.*

**17.2. LYMPHATIC SYSTEM :**

The lymphatic system is a network of **lymph capillaries**, **lymph vessels** and **lymph nodes**, through which a fluid, derived from the interstitial (tissue) fluid circulates. The amount of fluid, filtered from the blood into the surrounding tissues through the endothelial wall of the capillaries is known as the interstitial or tissue fluid. This fluid needs to be reabsorbed back into the blood in order to maintain the osmolality of the blood so that the blood volume and blood pressure are maintained at an optimum level. Indeed, a part of it is reabsorbed. However, the remaining part i.e. 4 L is absorbed and returned to the cardiovascular system through the lymphatic system.

Like blood capillaries, the lymphatic capillaries are endothelium lined very narrow vessels, present in the interstitium of all organs and tissues (Fig.17.8). But, unlike blood capillaries, these are closed-ended i.e. these are not drained by vessels. The lymphatic capillaries join to form lymphatic vessels, which join to form two large lymphatic vessels, one of which is known as the **right lymphatic duct** or **thoracic duct**. These ducts finally drain the lymph into the **right and left sub-clavian veins**, respectively (Fig.17.7). Structurally, the lymph vessels resemble the veins i.e. each has the same three-layered organization provided with valves at regular intervals to regulate unidirectional flow of the lymph. Before draining into the veins, the lymph is filtered in lymph nodes. The lymph node is a lymphoid tissue that contains lymphocytes, which locate and destroy pathogens, if any, present in the drained lymph.

There is no pumping organ for the circulation of lymph. The contractile tunica media, made by smooth muscle, contracts and propels the lymph forward. The backward flow is prevented by the presence of valves in the lymph vessels periodically.

Sometimes, the lymph vessels are occluded by parasites, consequently blocking the normal flow of the lymph. This results in the accumulation of excess interstitial fluid in the tissues and organs, causing massive swellings, known as **oedema** or **edema**. The commonest example is massive nodular tissues formed by the occluded lymphatic vessels by microfilariae of filarial worm. This condition is termed as **elephantiasis**.

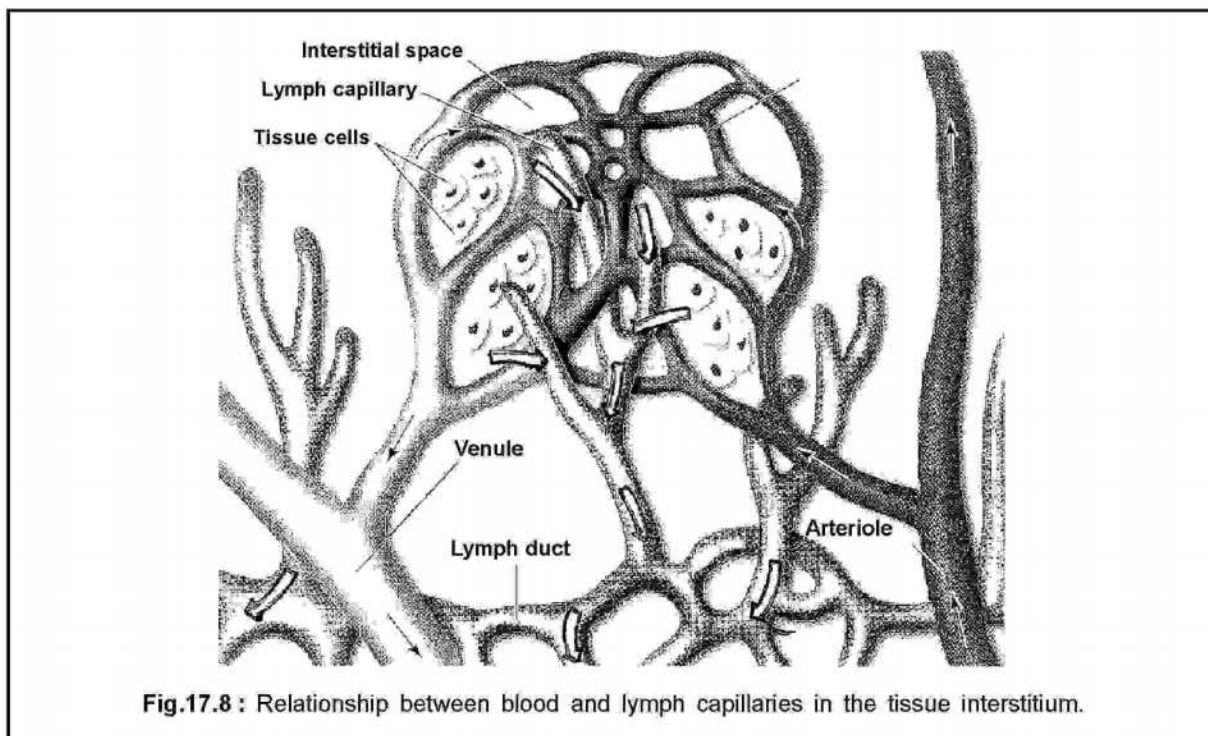
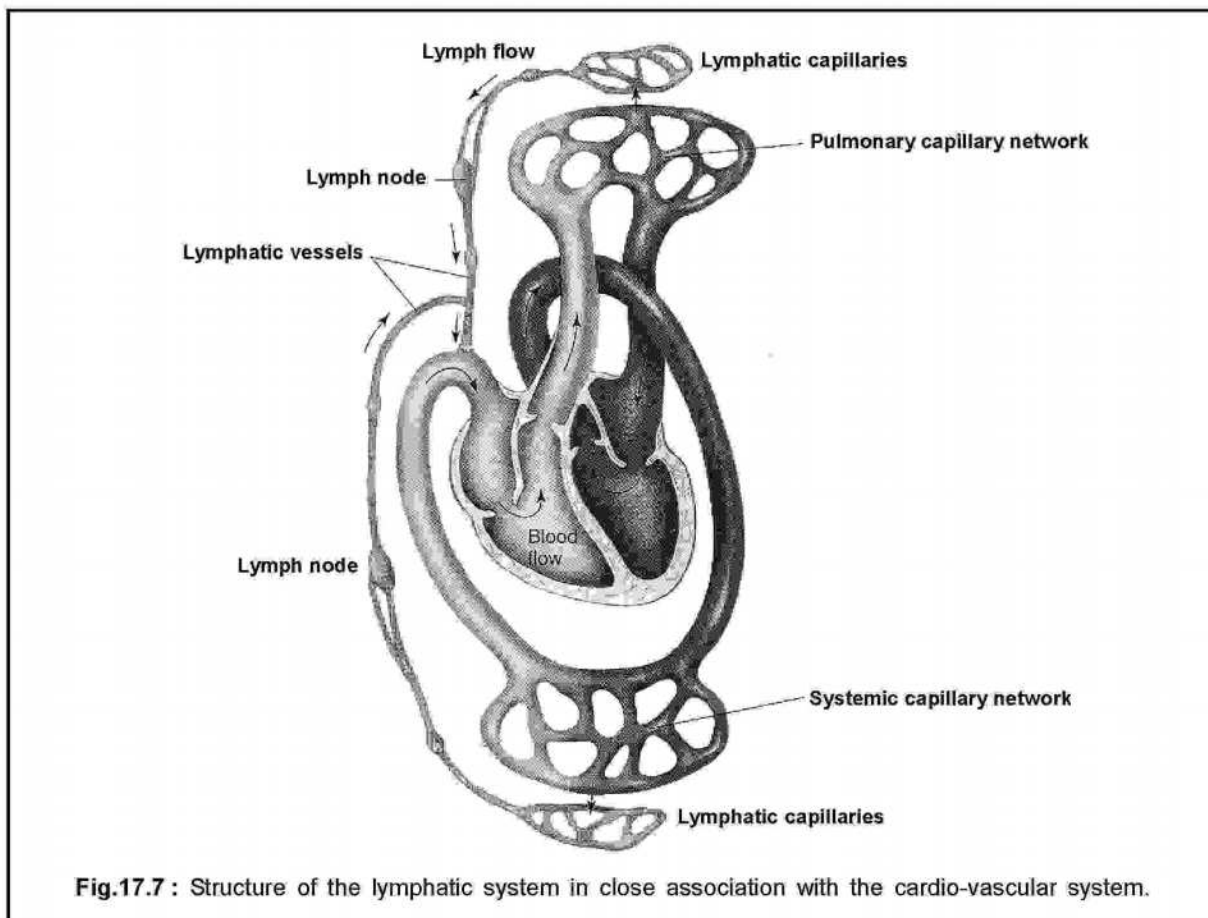

(g) **Atrial Natriuretic Peptide:** A rise in the blood volume leads to an augmented urine formation. Increased urine formation is coupled to an **increased excretion of Na<sup>+</sup> in the urine (natriuresis)**. A natriuretic peptide is produced by the atria of the heart, which promotes the excretion of Na<sup>+</sup> and water in the urine in response to a rise in the blood volume. It, thus, lowers the blood volume and pressure. It antagonizes ADH, angiotensin II and aldosterone.

### 17.3. BLOOD GROUPS.:

All cells of an individual bear, on their surfaces, characteristic molecules, which help them to identify as belonging to self. Any cell that bears a molecule of a different configuration is identified as **foreign or alien**. If, by chance, this foreign cell enters into the body of the individual, the immune system checks its surface, marks it as foreign and then destroys it. These surface molecules are known as **antigens** and are used as passport by all the cells of an individual. The cells bearing antigens of differing configuration are considered as foreign or from another individual. This is an important **biological basis of individuality**. Erythrocytes or red blood cells also bear surface molecules, which are known as **blood group antigens or agglutinogens**. The serum bears molecules, which are compatible with the blood group antigens. These are known as **antibodies or agglutinins**. Compatibility refers to the absence of an immune response. There are two main systems of human blood grouping: ABO system and Rh system.

Table - 17.2

Red cell surface antigens and compatible serum antibodies and genotypes in the ABO system

Blood Group	Red Cell Surface Antigen	Serum Antibody	Allelic Combination (Genotype)
A	A	Ani-B	I <sup>A</sup> I <sup>A</sup> and I <sup>A</sup> i
B	B	Anti-A	I <sup>B</sup> I <sup>B</sup> and I <sup>B</sup> i
AB	Both A and B	None	I <sup>A</sup> I <sup>B</sup>
○	None	Both Anti-A and Anti-B	ii

#### 17.3.1. ABO System:

Karl Landsteiner (1901) found that reactions between red cell antigens of one sample of blood and serum antibodies of another sample caused the red cells to clump together, causing adverse reactions in recipients. He was able to identify three blood groups : A, B and C (C later was termed as O), based on the surface antigens of red cells. Two of his coworkers, **Alfred von Decastello and Adriano Sturli (1902)** added the fourth group, AB to the list. These findings led to blood group classification in the ABO system as A, B, AB and O.



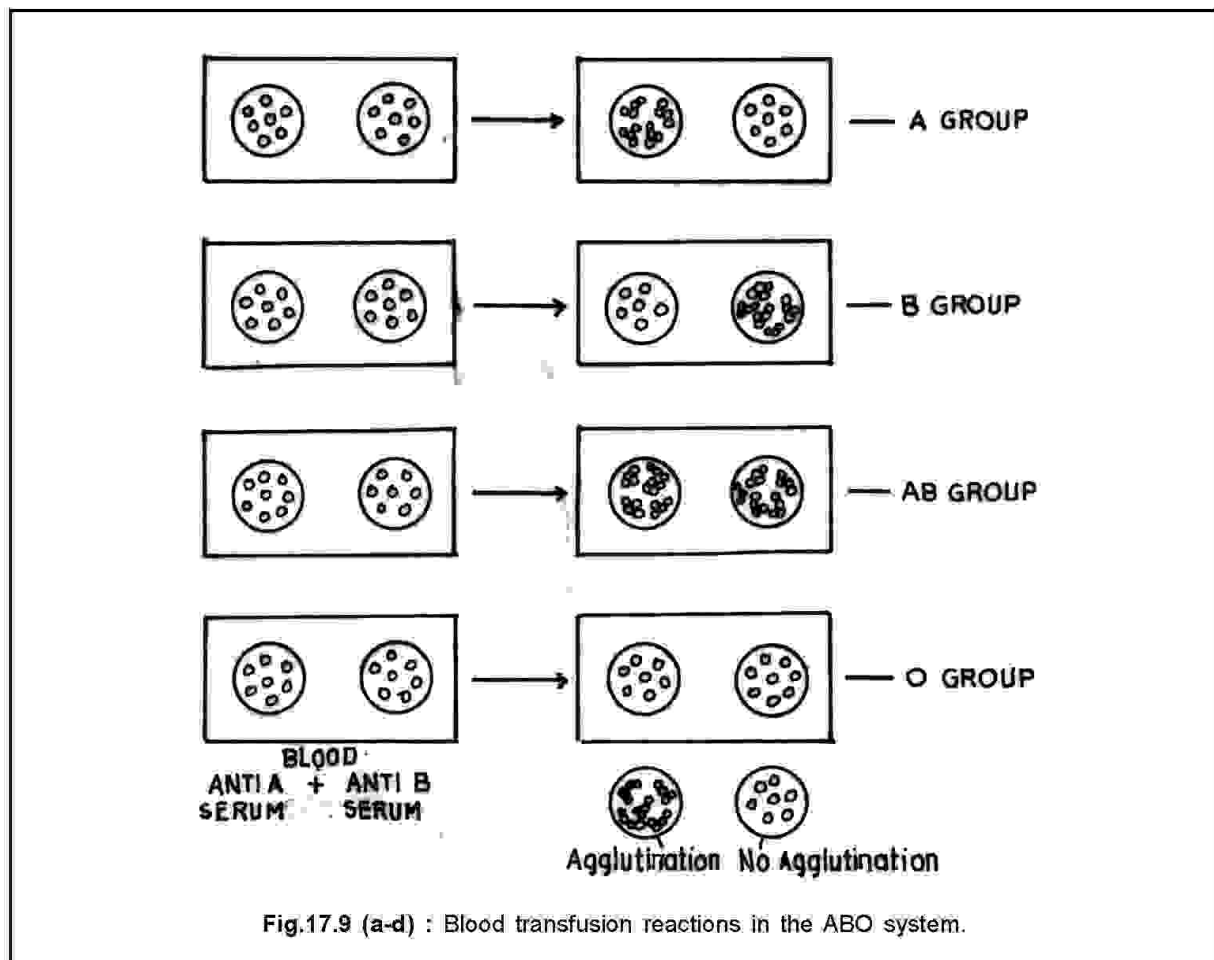

There are only two types of blood group antigens, such as A and B and two types of antibodies in the serum, such as anti-A and anti-B in the human population. A blood group may have A or B or both A and B or neither A nor B antigens on the surface of red cells. Similarly, the serum may have anti-B or anti-A or neither anti-A nor anti-B or both anti-A and anti-B antibodies. Table 17.2 summarizes the presence of red cell surface antigens and compatible Serum antibodies of the four types of blood groups in the ABO system.

#### (a) Transfusion Reaction :

Prior to blood transfusion, a cross-match is made by mixing the serum of the recipient and the blood cells of the donor. If the types do not match, for example the donor is type A and the recipient is type B, the recipient's serum antibody (anti A), will react with the red cell surface antigen (A) of the donor, in an antigen-antibody reaction forming a **clump** or **agglutinate**. From the agglutination reaction (Fig. 17.9), it is evident that a person possessing the blood group O is a **universal donor**, while a person with blood group AB is a **universal recipient**.

**(b) Genetics of ABO system :**

The blood group antigens are inherited in a dominant manner. Antigen A is expressed by the dominant allele  $I^A$ , while antigen B by the dominant allele,  $I^B$ . Both the alleles are dominant to the allele for O, i (lower case letter since the allele is recessive). Each person inherits two alleles, one from each parent. Thus, A and B have two allelic combinations,  $I^A I^A$  and  $I^A i$  for antigen A and  $I^B I^B$  and  $I^B i$  for antigen B. AB and O antigens have one combinations each, such as  $I^A I^B$  and  $ii$ , respectively (Table 17.2).

**17.3.2. Rh Factor (Fig. 17.10) :**

Alexander S. Wiener (1937) discovered another group of antigens, which are found on red cells of most people. This was named as the Rh factor. The notation, Rh is derived from rhesus monkey, in which these antigens were first discovered. There are a number of antigens in this group, such as C, D and E. However, the antigen, D is termed as Rh antigen and is important for its clinical significance. If D antigens are present on the red cell surface of a person, the person is considered as Rh positive and if absent, the person is Rh negative.

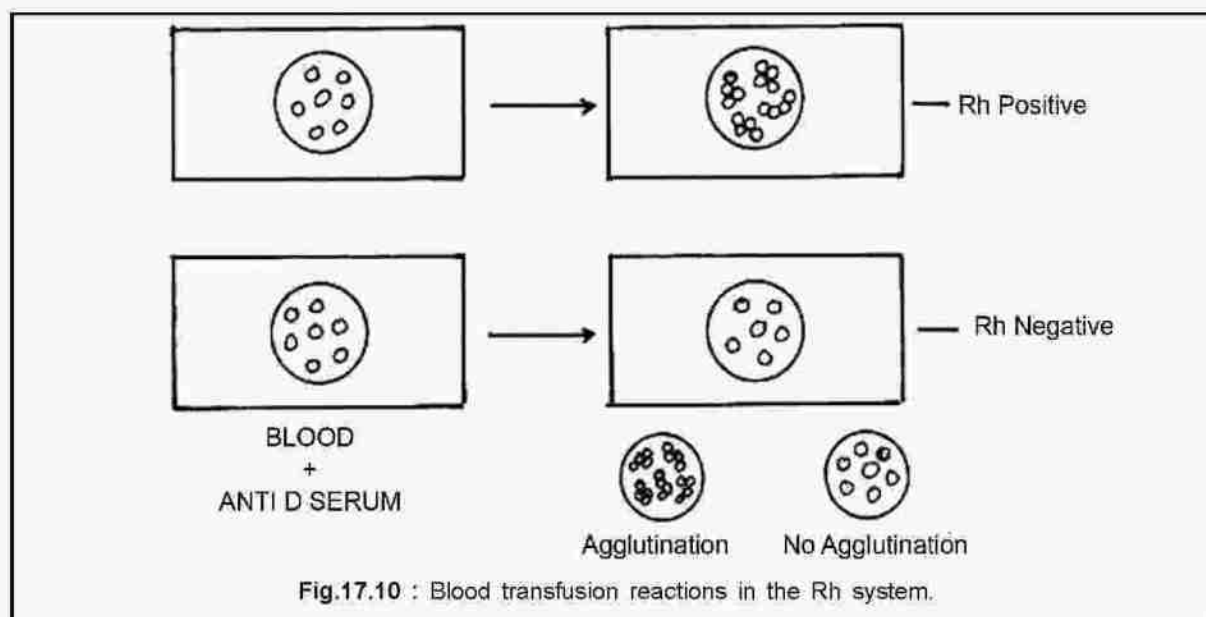

The Rh factor is of particular significance, when Rh negative woman conceives and gives birth to Rh positive baby. The blood of the mother and the baby are normally kept apart by the placental barrier and hence, do not mix during the pregnancy period. Thus the Rh negative mother is not exposed to the Rh antigens. However, an exposure may occur at the time of birth. Consequently, the Rh negative mother's immune system may be sensitized and anti-Rh antibody may be synthesized. If the mother conceives Rh positive baby subsequently thereafter, the anti-Rh antibody may cross the placental barrier and enter into the fetal circulation. These antibodies react with the Rh antigen, present on the red cell surface of the

fetus and result in the clumping of the fetal red cells by antigen-antibody reaction. This causes haemolysis of the red cells of the fetus. The fetus is born, either dead or live and anemic with a condition, called **erythroblastosis fetalis** or **hemolytic disease of the newborn**.

Erythroblastosis fetalis is prevented by injecting the Rh negative mother with an antibody preparation against the Rh antigen (**RhoGAM** is the trade name for this preparation). This preparation is injected within 72 hr after the birth of each Rh positive baby. This is a type of **passive immunization**, in which the antibodies inactivate the Rh antigen and thus prevent the mother from becoming **actively immunized** to them.

#### 17.4. BLOOD CLOTTING (COAGULATION) :

The circulatory system has an intrinsic mechanism of preventing excess loss of blood from an injured part of the body. This is done by forming a **clot** or **thrombus**. The clot is made up of a mesh of an insoluble protein, fibrin. It holds back the blood cells. A clear fluid, called **serum**, oozes out from the wound. This process of forming clots in the walls of damaged blood vessels and preventing blood loss is known as **hemostasis**. When a blood vessel is injured, a number of physiological mechanisms are activated that promote hemostasis. The collagen protein from the sub-endothelial tissue of the damaged blood vessel is exposed. This initiates three events : **vasoconstriction**, **formation of a platelet plug**, and **formation of a fibrin mesh**.

##### 17.4.1. Mechanism of clotting :

1. As long as the endothelium of a blood vessel is intact, the platelets circulating in it, repel each other and keep away from the endothelial cells by repulsion.
2. The endothelial cells secrete **prostacyclin** [prostaglandin ( $\text{PGI}_2$ )] and **nitric oxide** (NO). These act as vasodilators and inhibit platelet aggregation.

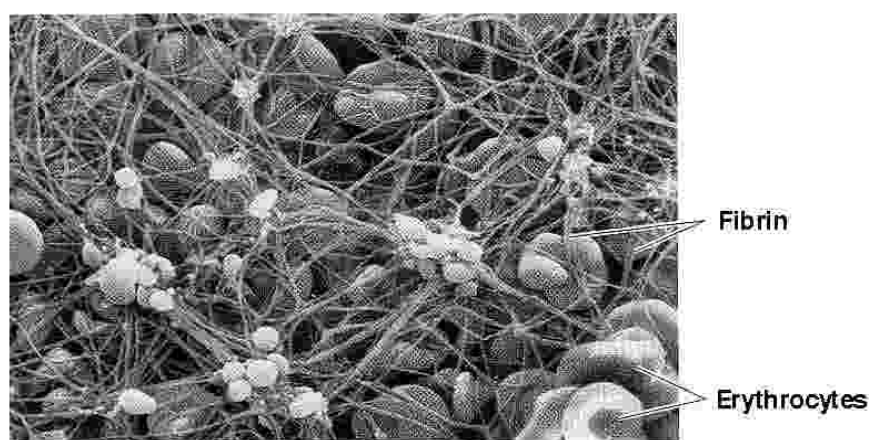

Fig.17.11 : Scanning electronmicrograph of a fibrin mesh.

3. The plasma membrane of endothelial cells has a **membrane bound enzyme, CD 39** that hydrolyzes ADP into AMP and Pi. ADP, as such, promotes platelet aggregation. The breakdown of ADP into AMP and Pi, thus, prevents platelet aggregation.
4. These are only a few protective mechanisms, which ensure that platelets do not form aggregates nor do they stick to the endothelium as long as the endothelium is intact.
5. When a blood vessel is injured, the endothelium is broken and consequently, the platelet plasma membrane bound proteins bind to collagen. This binding is facilitated by **von Willebrand's factor (VWF)**, which binds to the platelet membrane on the one hand and to the collagen fibers on the other.
6. When platelets stick to collagen, they degranulate releasing **ADP, serotonin** and **thromboxane A<sub>2</sub> (TxA<sub>2</sub>)**. This phenomenon is known as **platelet release reaction (Fig. 17.12)**. ADP and TxA<sub>2</sub> recruit new platelets to the site, thus forming a second

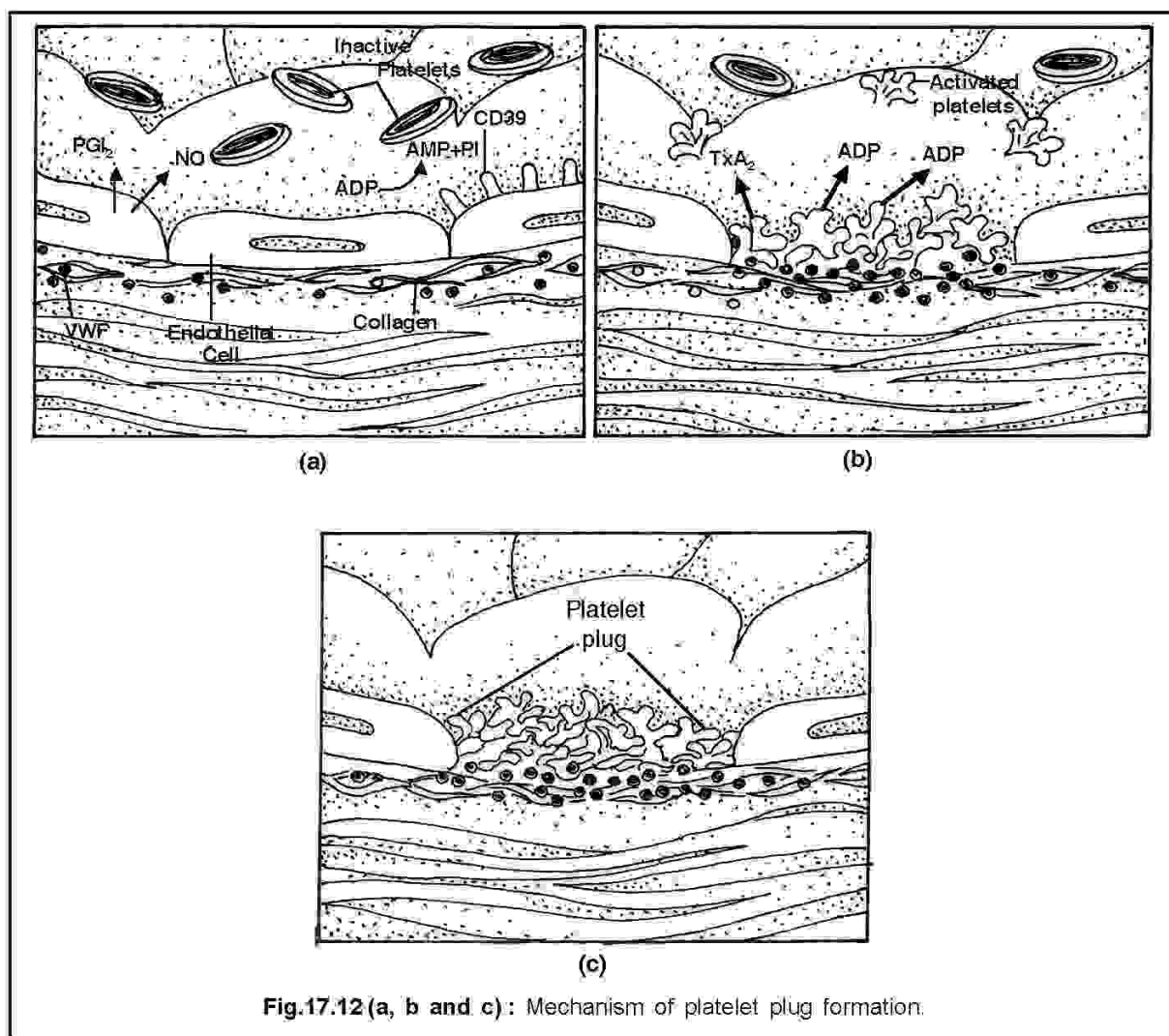
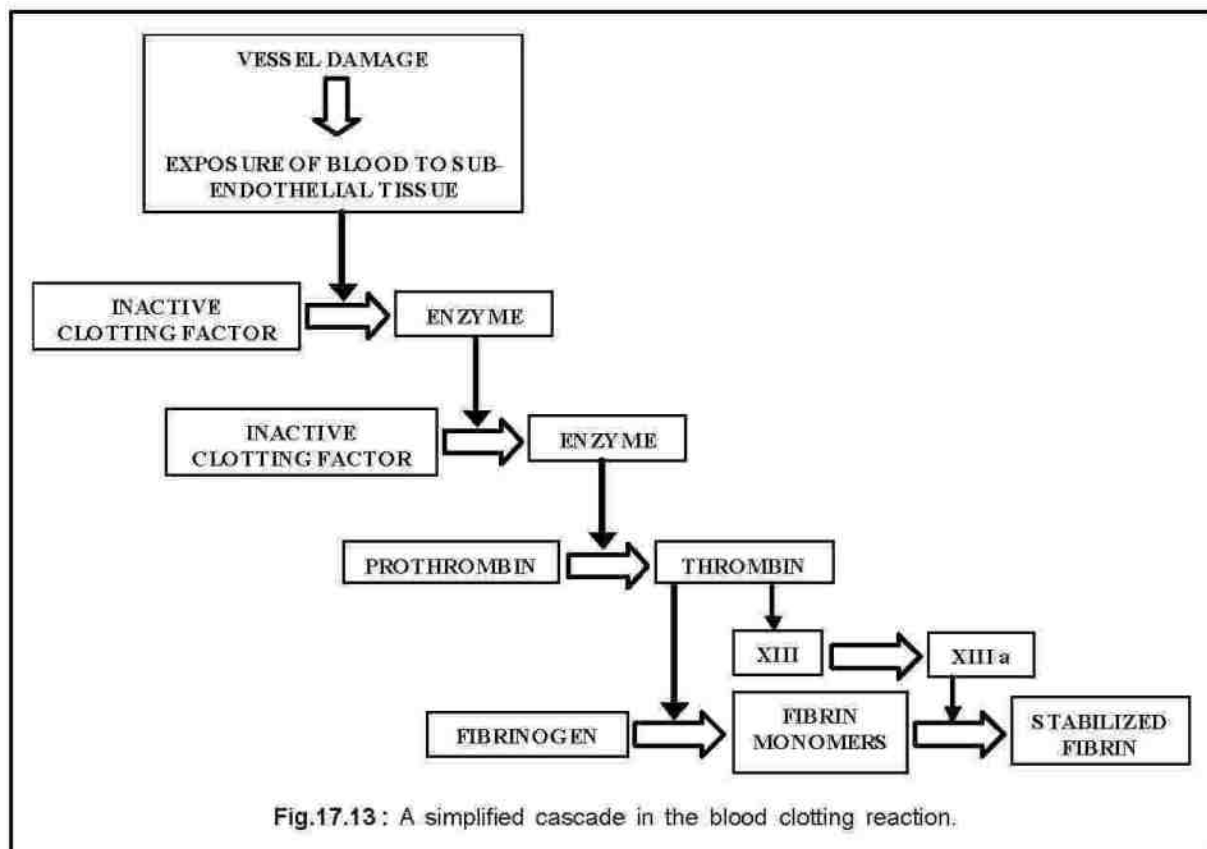

Fig.17.12(a, b and c): Mechanism of platelet plug formation.

layer. This second layer undergoes another platelet release reaction to form the third layer and so on. This produces a platelet plug (Fig.17.12) at the site of the injury.

- The activated platelets then activate several plasma clotting factors in a cascade ending in soluble fibrinogen changing into insoluble fibrin mesh (Fig.17.11), which holds back the oozing out blood cells.



#### 17.4.2. Plasma Clotting Factors and formation of Fibrin :

The conversion of fibrinogen into fibrin mesh occurs via either of the two pathways: (1) intrinsic pathway and (2) extrinsic pathway.

(1) **Intrinsic pathway (Fig.17.14)**: Blood left in a test tube will clot without the addition of any external chemical. This pathway also forms a clot in the damaged blood vessels. The pathway is initiated by the exposure of the plasma to a negatively charged surface like that of collagen at the site of a wound. The negatively charged surface is also provided by the glass surface of a test tube. This process activates a plasma protein, called factor XII (Hageman's factor). It is a protease (protein digesting enzyme). The activated factor XII activates the inactive factor XI, which activates yet another and so on. These sequential activation reactions constitute a cascade. A simplified blood coagulation cascade is presented in Fig.17.13.

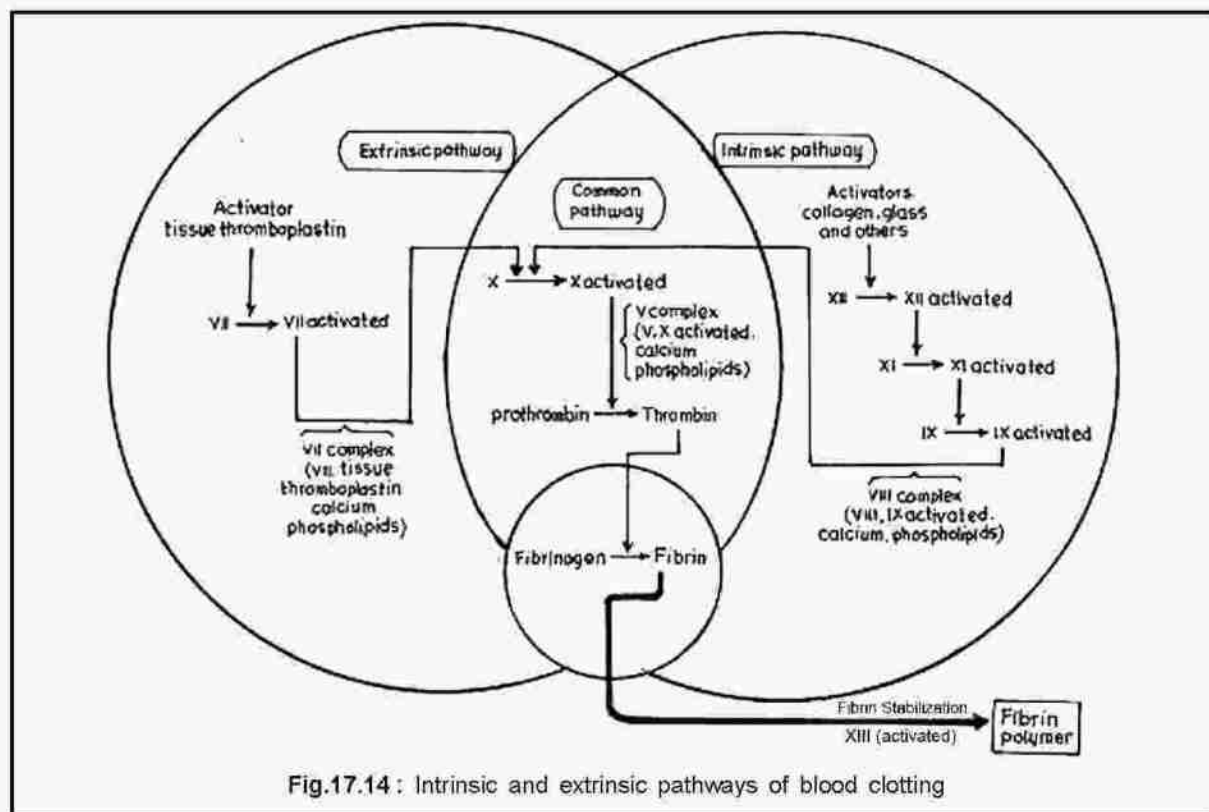

Fig.17.14 : Intrinsic and extrinsic pathways of blood clotting

In the next step, calcium ions and phospholipids convert an inactive glycoprotein enzyme, prothrombin into its active form, thrombin. In the final step, thrombin converts soluble fibrinogen into fibrin monomers. The fibrin monomers are joined forming insoluble fibrin polymers. The fibrin polymers are stabilized by the activated factor XIII. The fibrin polymer forms a mesh, supporting the platelet plug and thus prevents loss of blood.

(2) **Extrinsic pathway** [Fig.17.14]: In the extrinsic pathway, additional factors are required for the clot formation. For example, fibrin can be formed by a shortcut route by the release of tissue thromboplastin from the damaged tissue cells. The two pathways converge at the activation reaction of the inactive factor X.

#### 17.4.3. Anticlotting mechanism :

Clotting reactions continue as long as there is a loss of blood. The moment the clot is formed and blood outflow is checked, the clotting reactions are suspended. There are several mechanisms, which prevent clotting inside blood vessels and break down any clot that is formed.

1. There is an interaction between the platelet aggregating effect of thromboxane  $A_2$  and antiaggregating effect of prostacycline.
2. **Antithrombin III** is a circulating plasma protein, which inactivates thrombin and several other clotting factors. In order to do so, antithrombin III itself is activated by heparin, a substance that is present at the surface of endothelial cells.

**Table - 17.3**  
**The Plasma Clotting Factors**

Clotting Factors	Name	Function
I	Fibrinogen	Converted to fibrin by thrombin
II	Prothrombin	Converted to thrombin
III	Tissue thromboplastin	Cofactor (Activator of factor VII)
IV	Calcium ions ( $Ca^{2+}$ )	Cofactor (Conjugate activator of factor X and prothrombin)
V	Proaccelerin	Cofactor (Conjugate activator of prothrombin)
VII	Proconvertin	Enzyme (Conjugate activator of factor X)
VIII	Antihemophilic factor	Cofactor (Conjugate activator of factor X)
IX	Plasma thromboplastin Component (Christmas factor)	Enzyme (Conjugate activator of factor X)
X	Stuart-Prower factor	Enzyme (Conjugate activator of prothrombin)
XI	Plasma thromboplastin antecedent	Enzyme (Activates factor IX)
XII	Hageman factor	Enzyme (Activates factor XI)
XIII	Fibrin stabilizing factor	Enzyme (Stabilizes fibrin monomers into fibrin polymer)
HMW-K	High mol. Weight kininogen (Fitzgerald factor)	Activates XII to XIIa and XI to XIa
Pre-K <sub>a</sub>	Prekallikrein (Fletcher factor)	Inactive Kalikrein, activated by factor XII
K <sub>a</sub>	Kallikrein	Activates plasminogen into plasmin.
PL	Platelet phospholipid	Activates many factors in conjunction with $Ca^{2+}$ and other activated factors.

3. The plasma protein, **tissue factor pathway inhibitor (TFPI)** is a plasma protein that binds to activated factor VII complex and inhibits the formation of active factor X.
4. All endothelial cells, except those in the cerebral microcirculation produce **thrombomodulin**. It binds to thrombin. Thrombin alone activates factors V and VIII, while in combination with thrombomodulin, activates protein C. Activated protein C inactivates factors V and VIII.
5. **Plasmin** or **fibrinolysin** is the activated form of plasminogen. It is an enzyme, which lyses fibrin. However, plasminogen is present as such and when the clot formation is complete, it is activated by a protein activator, called **tissue plasminogen activator (tPA)**. Human tPA is now produced by recombinant DNA technology and is available for clinical use.

**Blood Clotting Disorders :**

*Many hereditary disorders occur due to the defective blood clotting factors. Three are noteworthy in this context. One is **haemophilia A**, which is caused by the deficiency of a sub-unit of factor VIII. It is an **X-linked recessive disorder** that is prevalent in the royal families of Europe. A deficiency in another sub-unit of factor VIII results in **von Willebrand's disease**. In this disease, rapidly circulating platelets are unable to stick to collagen and consequently a platelet plug can not be formed. von Willebrand's disease is an **autosomal dominant disorder**. The deficiency of another factor, factor IX causes the inherited disorder, **haemophilia B** or **Christmas disease**. It is an **X-linked recessive disorder**. Blood coagulation factors, VIII and IX have been synthesized by recombinant DNA technology on a commercial basis and marketed for clinical use.*

6. Blood coagulation factor XII converts an inactive plasma component, **prekallikrein** into an active **kallikrein**. **Kallikrein** is an activator of **plasminogen** and activates it into **active plasmin**. Plasmin is a protease, which acts on fibrin and dissolves it. A bacterial enzyme, **streptokinase** also activates plasminogen into plasmin. Streptokinase and tPA are injected into the general circulation to dissolve a clot or thrombus.

**Types of heart :**

There are two types of heart: **neurogenic** and **myogenic**. In a neurogenic heart, the muscle cells are incapable of initiating the heart beat. A group of nerve cells (ganglion) initiates the heart beat (e.g.; arthropods and molluscs). Conversely, in a myogenic heart, the nerve stimulation is not required for initiating the heart beat. A few localized cardiac muscle cells are specialized to initiate the heart beat. The collection of specialized cardiac muscle cells constitutes a **node**. For example, **sino-atrial (SA) node** in the right atrium of human heart initiates the heart beat (e.g.; vertebrates). It is known as the **pace maker**.

**17.5. STRUCTURE OF HUMAN HEART (Figs. 17.15, 17.16 and 17.17) :**

The heart is a conical muscular pumping organ, present in the middle mediastinum of the thoracic cavity. It is enclosed by a pericardium. The pericardium is a fibrous sac surrounding the heart and the roots of great vessels. It consists of an **outer fibrous** and an **inner serous layers**. The fibrous pericardium is a tough connective tissue outer layer that defines the boundary of the middle mediastinum. The serous pericardium, also known as the **epicardium**, consists of **outer parietal layer** and **inner visceral layer**. Both the layers are continuous at the roots of great vessels. There is a **pericardial fluid** in the space between the parietal and visceral layers. This fluid protects the heart from friction, caused during its contraction and relaxation.



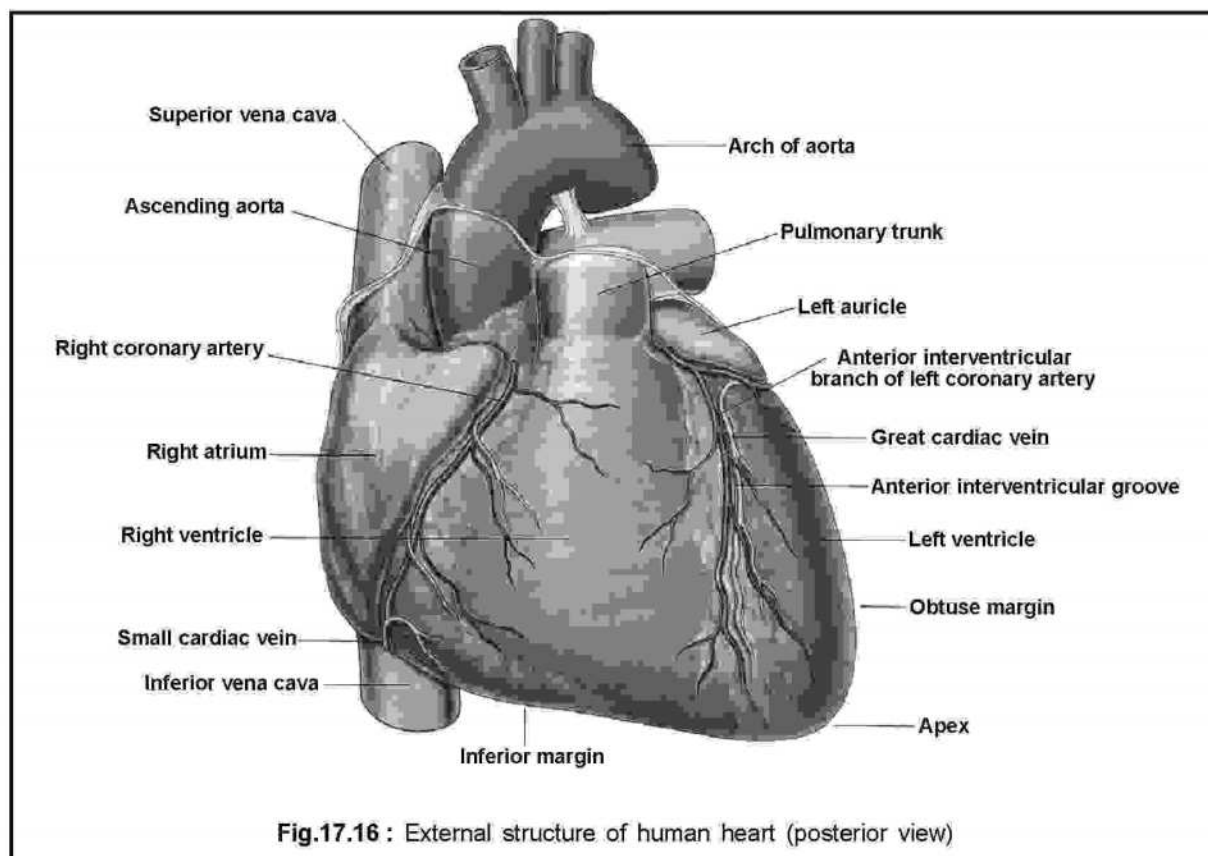
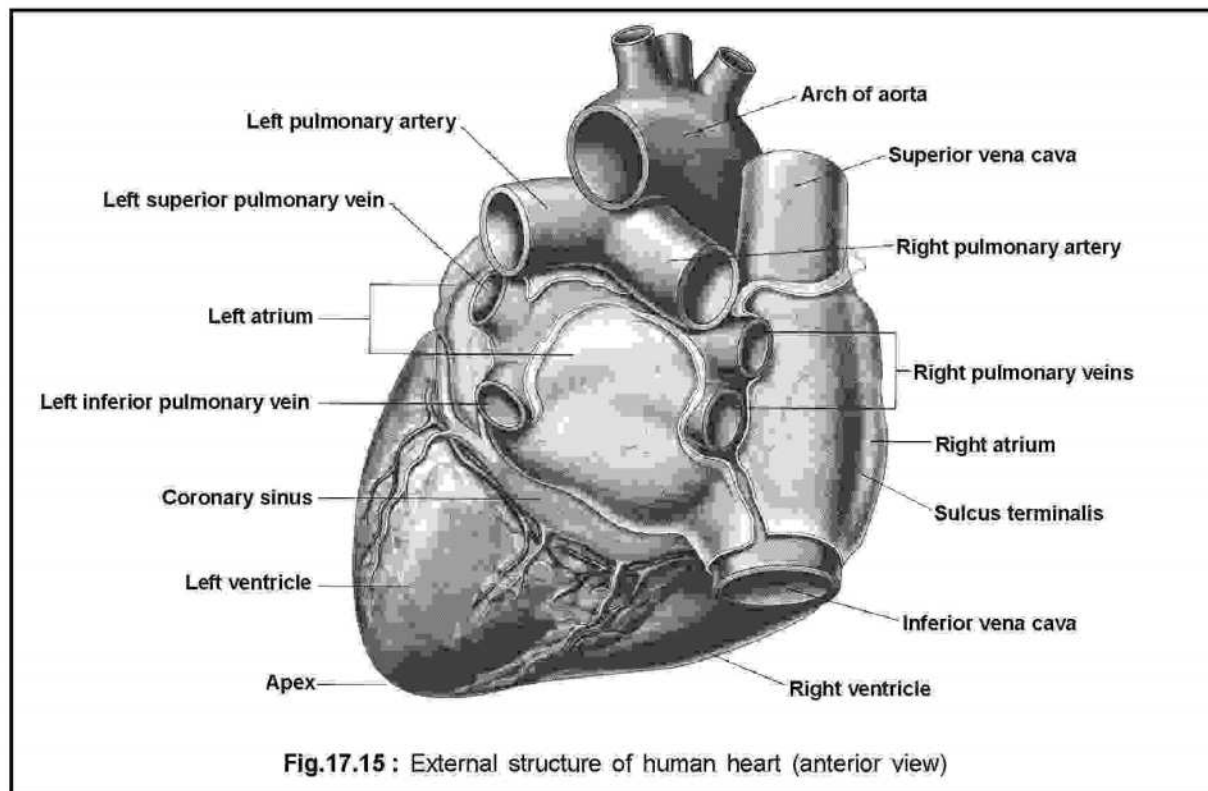

The shape of the heart is conical or pyramidal. The shape is comparable to that of a pyramid that has fallen over and is resting on one side. The apex projects forward, downward and to the left. The heart is four chambered consisting of **two atria** and **two ventricles**. Internally, the chambers are separated from each other by partitions. These partitions conform to the external grooves, called **sulci** (singular; sulcus). The atria are separated from the ventricles by a **coronary sulcus**. This groove harbours the coronary sinus, cardiac vein, right coronary artery and a branch of left coronary artery. The ventricles are separated from each other by anterior and posterior inter-ventricular sulci.

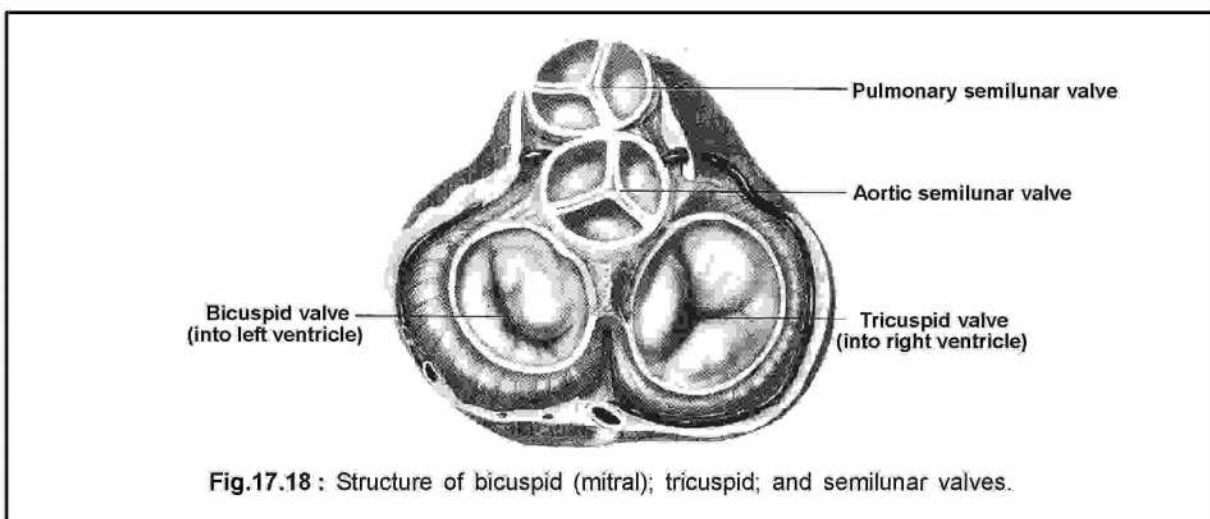
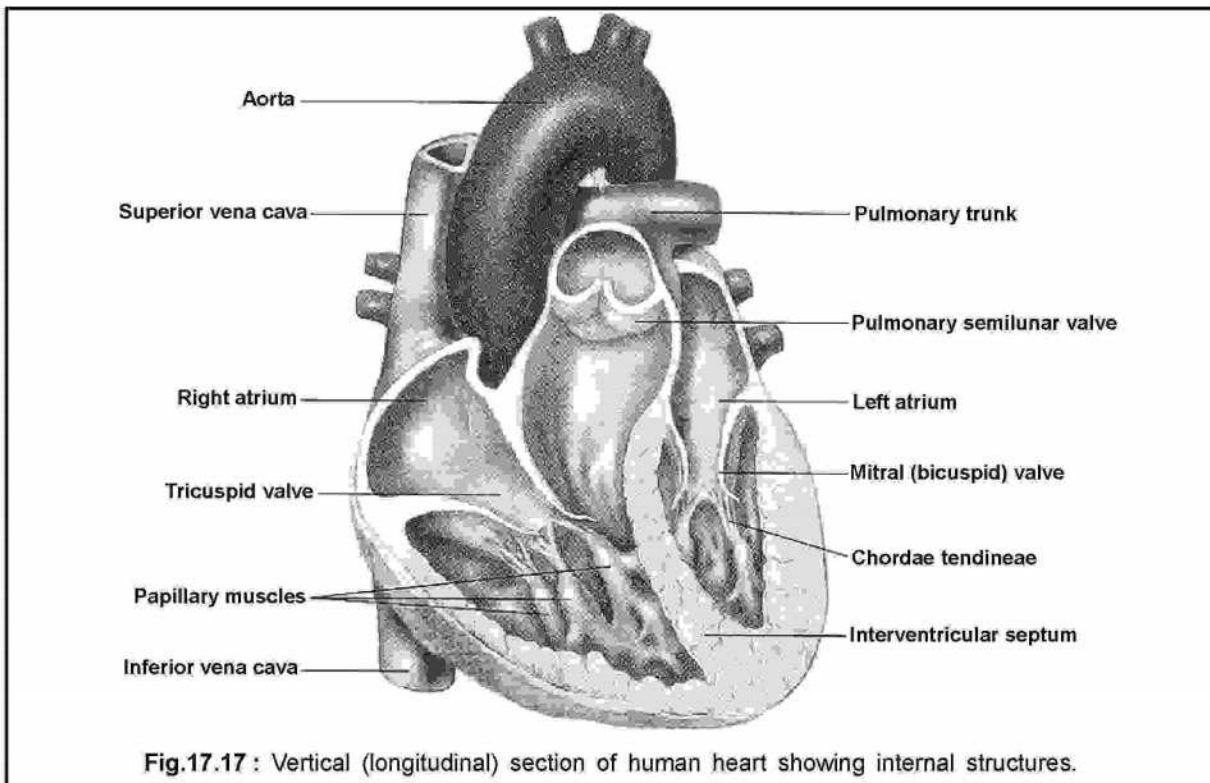

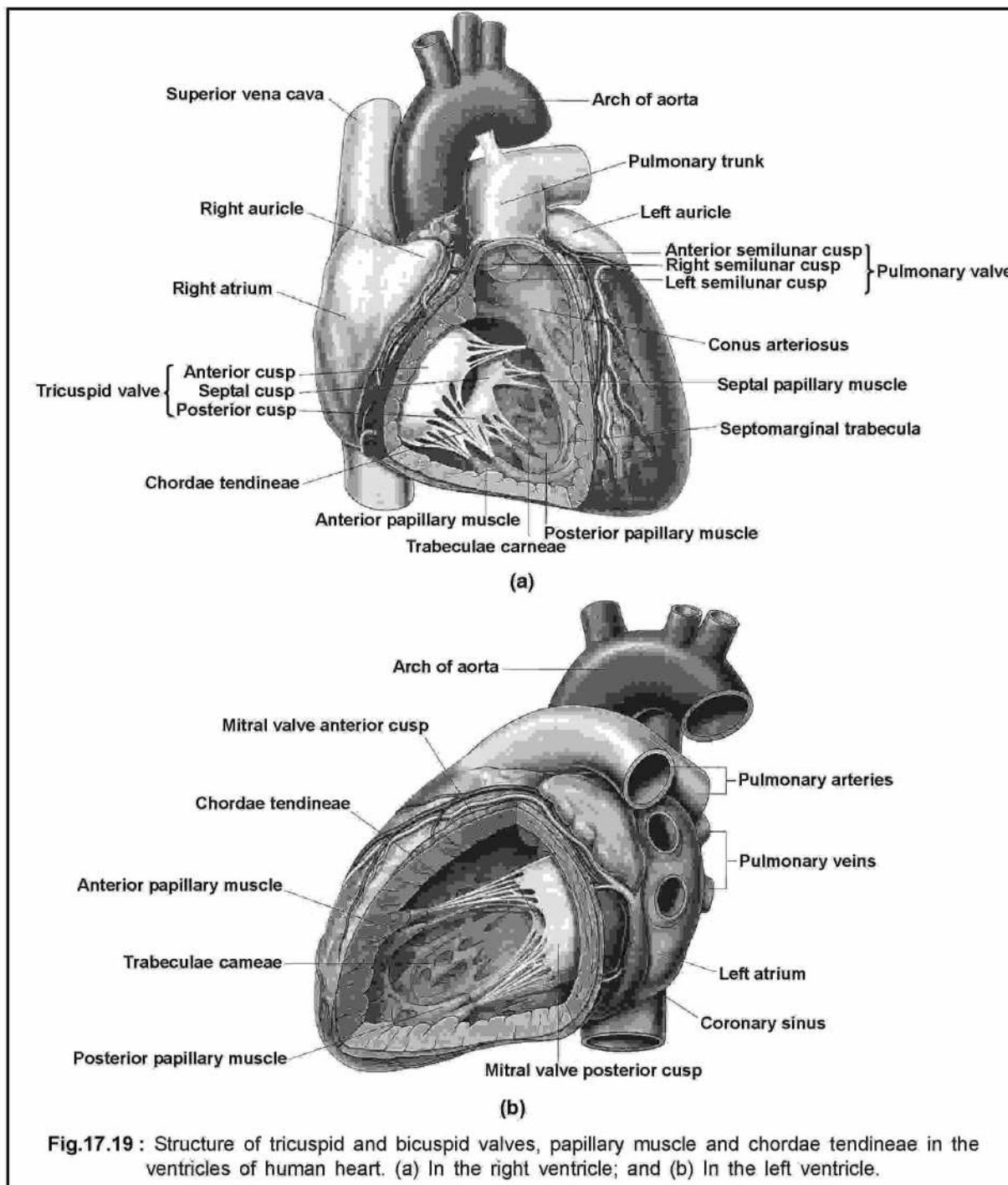

**Foramen ovale and Ductus arteriosus :**

*The lungs of the fetus are collapsed and non-functional. Therefore, the circulating blood bypasses the pulmonary circulation by developing two features in the heart. One, known as **foramen ovale**, is a communication between the two atria and the other, known as **ductus arteriosus**, a vascular connection between the pulmonary trunk and aorta. Both the communications close at birth except in few, where these structures exist as congenital deformities.*

The wall of the heart consists of three layers : **outer epicardium, middle myocardium and inner endocardium**. The epicardium is synonymous with the visceral layer of the serous pericardium. It consists of simple squamous epithelium, called **mesothelium** and an underlying layer of sub-epicardial layer of connective tissue. This layer contains blood vessels, nerve fibers and adipose tissue. The myocardium consists of cardiac muscle. The endocardium consists of an inner simple squamous epithelium, called **endothelium** and an outer thin layer of sub-endothelial connective tissue. This layer contains small blood vessels and Purkinje fibers.

The heart is considered as having two pumps, the right and left. The right pump is constituted by the right atrium and the right ventricle, while the left by the left atrium and left ventricle.

#### 17.5.1. Atria :

Two atria are separated from each other by a complete partition, the **inter-atrial septum**. The septum is seen to have a depression just above the inferior venacava orifice, known as **fossa ovalis**. In human fetus, the two atria communicate with each other through a foramen, called **foramen ovale**. The oxygenated blood entering into the right atrium directly passes to the left atrium through this foramen, bypassing the lungs, since the lungs are collapsed in the fetus. However, foramen ovale closes soon after birth, leaving a footprint, called fossa ovalis. The right atrium receives deoxygenated blood from the **superior and inferior venacavae** and the **coronary sinus**. The left atrium receives blood from two **pulmonary veins**.

#### 17.5.2. Ventricles :

There are two ventricles, right and left, separated by a relatively thicker **inter-ventricular septum**. The right atrium opens into the right ventricle through a right atrio-ventricular orifice, guarded by a valve, known as **tricuspid valve**. The valve is named so because it is made by three cusps or leaflets. A pulmonary trunk originates from the right ventricle, which later divides into two pulmonary arteries.

The opening of the pulmonary trunk is guarded by three **semilunar valves** or **cusps**. The wall of the right ventricle has a few irregular muscular structures, called **papillary muscles**. The free surface of each papillary muscle is attached to tendon-like fibrous cords, known as **chordae tendineae** [Fig.17.19 (a)]. These are joined to the free edges of the cusps of tricuspid valves. The left atrium communicates with the left ventricle through a left atrio-ventricular orifice, guarded by a **bicuspid** or **mitral valve**. The aortic trunk originates from the left ventricle. The opening of the trunk is guarded by three semilunar valves. The papillary muscles are fine and delicate in comparison to those of the right ventricle. Chordae tendineae are seen as attachments between papillary muscles and free edges of the bicuspid valve [Fig.17.19 (b)]. For tricuspid, bicuspid (mitral) and semilunar valves, see Fig.17.18.

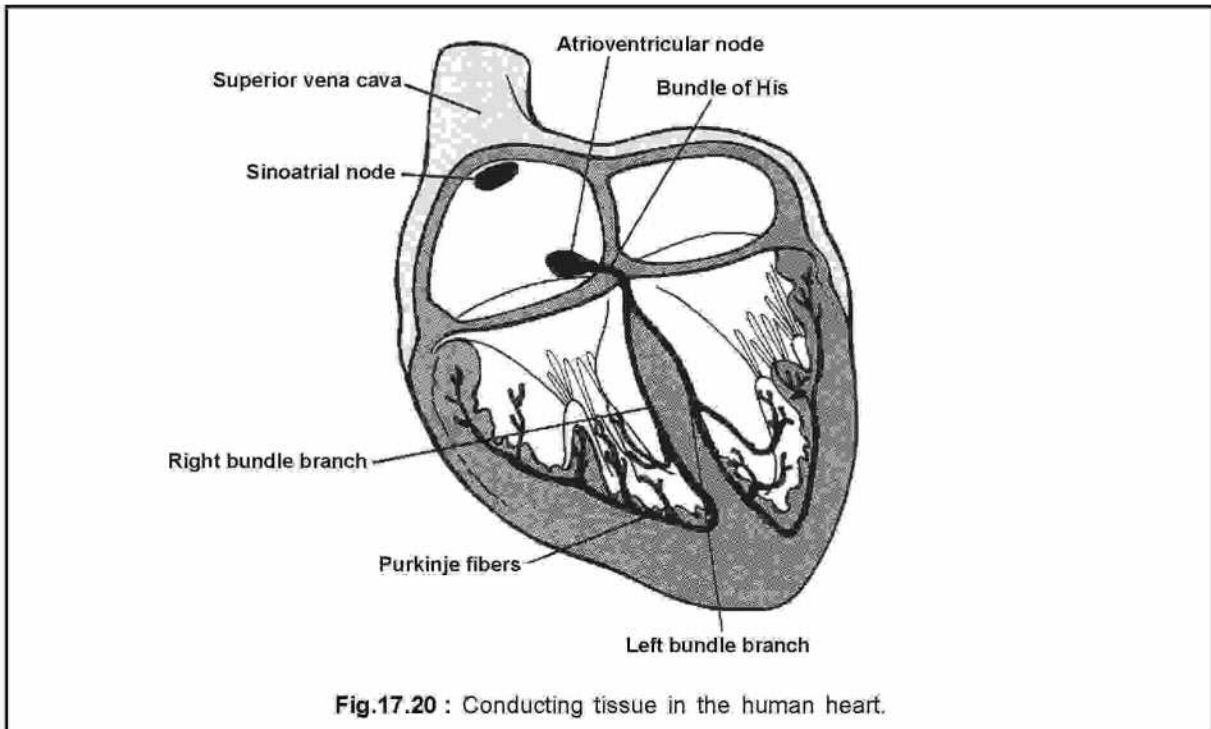

**17.5.3. Conducting tissue of the heart :**

Human heart is myogenic i.e. cardiac muscle cells are specialized to initiate and conduct impulses from atria to ventricles in a rhythmic manner. No innervation is necessary for this work. Contraction of cardiac muscle is due to depolarization of the plasma membrane of the cells making up the muscle. Depolarization creates an **action potential**, which spreads from cell to cell. The initial depolarization arises in a small group of cardiac muscle cells near the entry of the superior venacava into the right atrium. These cells are specialized for initiating and conducting the impulse, which constitute a node, the **sino-atrial (SA) node**.

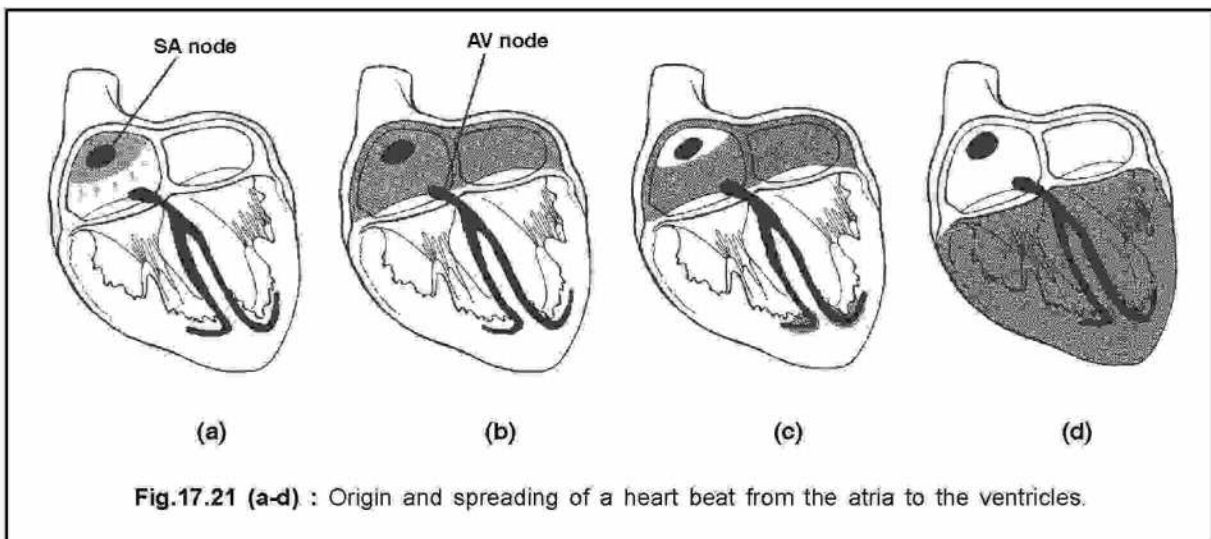

The action potential caused by the depolarization of the sino-atrial node spreads rapidly to the ventricles in a manner that the atria will contract first and then the ventricles. Since the SA node initiates depolarization and spreads it to the ventricles, it is called the **cardiac pacemaker** (Fig. 17.20). The SA node conducts the depolarization to another node, called **atrio-ventricular (AV) node**, situated at the base of the right atrium. There are three bundles of atrial fibers made up of Purkinje type fibers, which connect the SA node to the AV node. These are: the **anterior internodal tract of Bachman**, the **middle internodal tract of Wenckebach** and the **posterior internodal tract of Thorel**. However, there is a debate on the role of these bundles.

Histologically, the conducting system of the heart consists of modified cardiac muscle cells. The SA node and to a lesser extent, the AV node contain small rounded cells, which are connected by gap junctions. These cells, possibly, act as pacemaker cells and therefore, are known as **P cells**.

The impulse is carried to the ventricles via the conducting fibers in the inter-ventricular septum, constituting **bundle of His**. The bundle divides within the septum into **left and right bundle branches**. The bundle branches are continuous with the **Purkinje fibers**, within ventricular walls.

#### 17.5.4. Working of the heart (Fig.17.22) :

The deoxygenated blood from all parts of the body is poured into the right atrium via the superior and inferior venacavae. Similarly, the left atrium receives oxygenated blood from the pulmonary veins. The contents of the two atria do not mix due to the presence of an inter-atrial septum. Two atria undergo **systole** almost simultaneously and their contents are emptied into the ventricles of their respective sides. The right atrium drains the deoxygenated blood into the right ventricle through the right atrio-ventricular aperture, which is guarded by a tricuspid valve. The name is so, because it consists of three cusps. The valve opens only into the right ventricle and thus prevents the backward flow of blood into the right atrium. The oxygenated blood from the left atrium is pumped into the left ventricle through the left atrio-ventricular aperture, guarded by a bicuspid or mitral valve. It consists of two cusps as against three in the tricuspid valve. It opens into the left ventricle only and thus prevents the backward flow of blood into the left atrium.

As a matter of principle, with the commencement of relaxation of the atria, the ventricles will start contracting. However, the ventricles contract a little later than the commencement of relaxation of the atria. This means that both the atria and ventricles remain in **diastole** for a brief period. Alternately speaking, the entire heart is in diastole during this period. Whatever may be the case, the ventricles undergo systole and the deoxygenated blood from the right ventricle is forced into the pulmonary trunk, guarded by three semilunar valves. Similarly, the oxygenated blood in the left ventricle is forced into the aorta, guarded also by

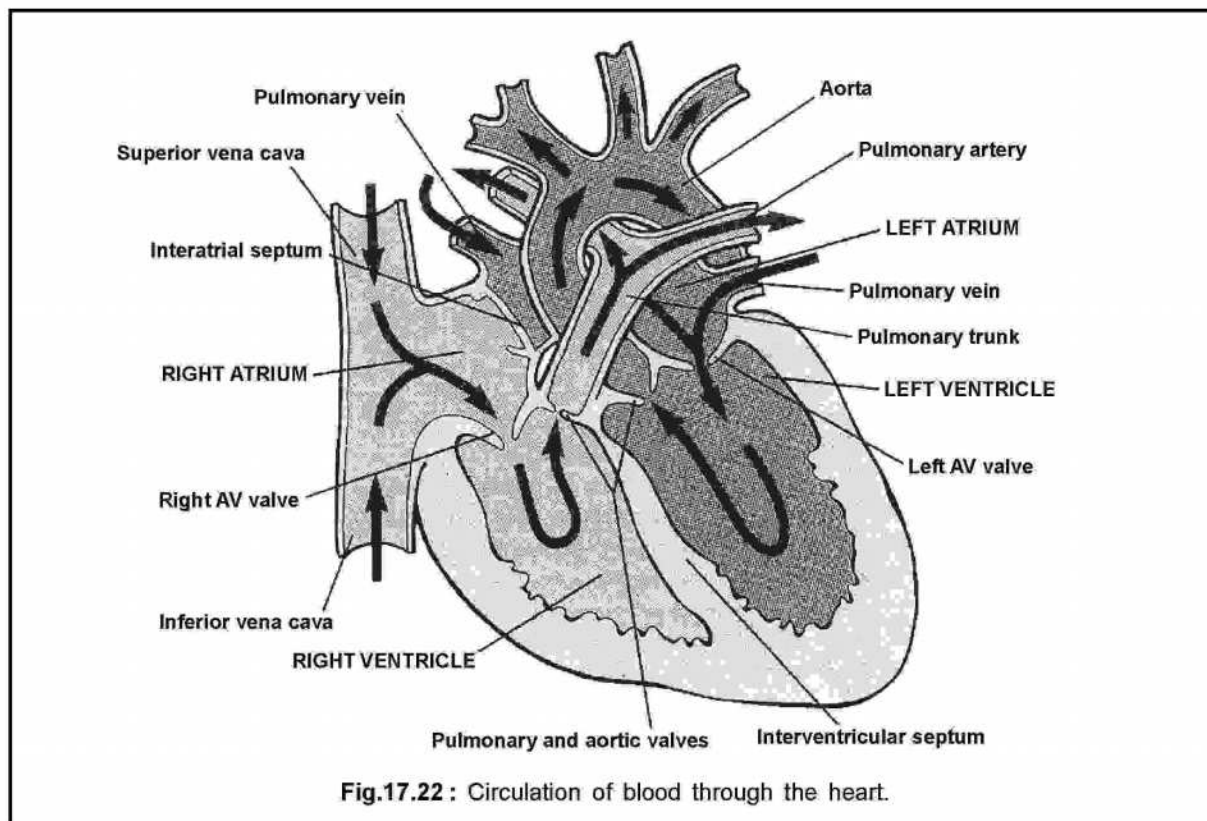

three semilunar valves. Both the semilunar valves are so arranged that the backward flow of blood from the pulmonary trunk into the right ventricle and from the aorta into the left ventricle is prevented. Thus, the valves ensure unidirectional flow of blood. With this, the cycle is completed. The blood in each half of the heart is completely separated from the other and thus deoxygenated and oxygenated blood do not mix at any point of time.

#### 17.5.5. Heart Beat :

Heart beat is the spontaneous and involuntary contraction of the cardiac muscle fibers in the SA node, which then spreads to whole of the atria and then to the ventricles (Fig.17.21). Like the contraction of a skeletal muscle fiber and the conduction of a nerve impulse, this is an electrical event. This is alternately explained as the propagation of **action potential** from atria to the ventricles. An action potential is a transient depolarization of the membranes of specialized myocardial cells in the SA node. The following events take place during the origin and conduction of impulse in the heart :

1. The resting myocardial cell has more potassium ions ( $K^+$ ) on the inner side and more sodium ions ( $Na^+$ ) on the outer side.
2. When the cell is not contracting, it is considered as being in the resting phase. The resting membrane potential is approximately  $-90$  mV (millivolt) (Fig.17.23).

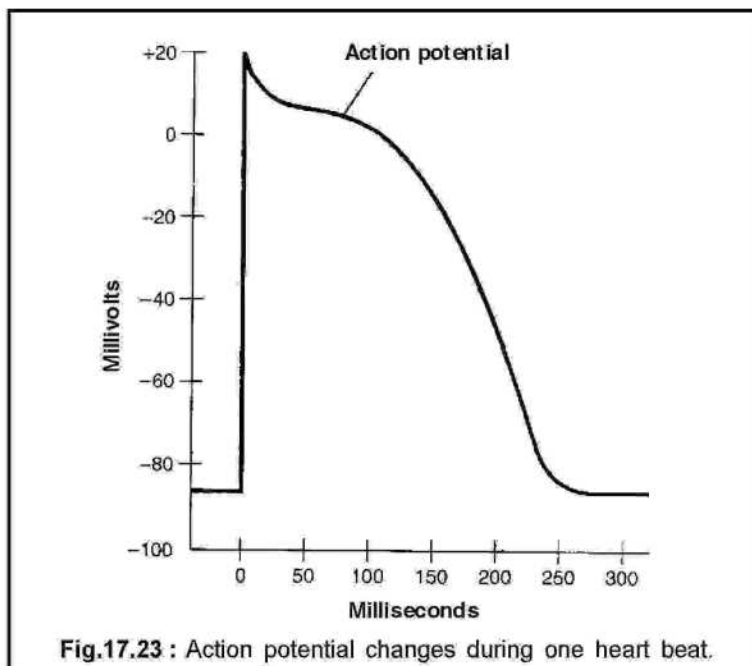

Fig.17.23 : Action potential changes during one heart beat.

Patients with **congestive heart failure** are treated with a drug, **digitalis**. It inactivates  $\text{Na}^+/\text{K}^+$  ATPase pumps in the plasma membrane of myocardial cells. Consequently, the cytoplasmic  $\text{Na}^+$  concentration rises and diffusion of  $\text{Na}^+$  into the cells is decreased. This reduces the ability of  $\text{Na}^+-\text{Ca}^{2+}$  exchanger to extrude  $\text{Ca}^{2+}$  from the cell. As a result, there is an increase in the cytoplasmic  $\text{Ca}^{2+}$  concentration and hence, the strength of myocardial contraction is increased.

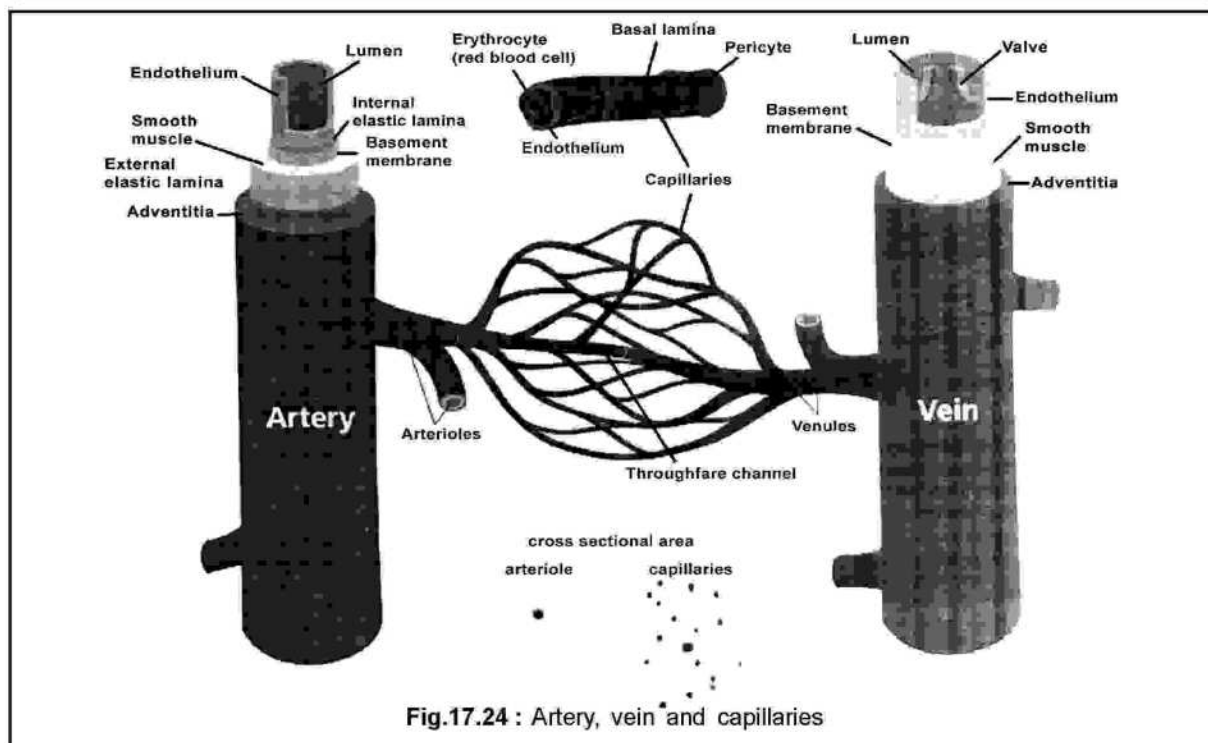

Fig.17.24 : Artery, vein and capillaries



3. When the cell contracts, the resting membrane is depolarized by the rapid influx of  $\text{Na}^+$  through rapidly opening  $\text{Na}^+$  channels. The potential goes up to a high of +20 mV (Fig.7.14). This spontaneous, **automatic depolarization** of the pacemaker occurs during diastole and therefore, it is also called **diastolic depolarization**.
4.  $\text{Na}^+$  influx is followed by slow  $\text{Ca}^{2+}$  influx through slowly opening  $\text{Ca}^{2+}$  channels.
5. Then, there is an efflux of  $\text{K}^+$  through voltage-gated  $\text{K}^+$  channels. This phase is termed as **repolarization**.

## 17.6. BLOOD VESSELS :

### Types

There are various kinds of blood vessels:

- Arteries
- Elastic arteries
- Distributing arteries
- Arterioles
- Capillaries (the smallest blood vessels)
- Venules
- Veins
  - Large collecting vessels, such as the subclavian vein, the jugular vein, the renal vein and the iliac vein.
  - Venae cavae (the two largest veins, carry blood into the heart).

They are roughly grouped as *arterial* and *venous*, determined by whether the blood in it is flowing *away from* (arterial) or *toward* (venous) the heart. The term “arterial blood” is nevertheless used to indicate blood high in oxygen, although the pulmonary artery carries “venous blood” and blood flowing in the pulmonary vein is rich in oxygen. This is because they are carrying the blood to and from the lungs, respectively, to be oxygenated.

## 17.7. CARDIAC CYCLE :

The healthy human heart beats 75 times per minute i.e. one beat covers  $60/75 \text{ sec} = 0.8 \text{ sec}$ . each beat completes through two distinct phases: **a phase of contraction (systole)** and **a phase of relaxation (diastole)**. Changes, which occur during one beat are repeated in the same rhythm and order in the next beat. This orderly repetition of changes in the heart from beat to beat is known as **cardiac cycle**. A cardiac cycle completes in 0.8 sec. Each event in the cardiac cycle is repeated in an interval of 0.8 sec.

There are four events in the cardiac cycle: **atrial systole**; **atrial diastole**; **ventricular systole**; and **ventricular diastole**. The cardiac cycle may be represented by two concentric

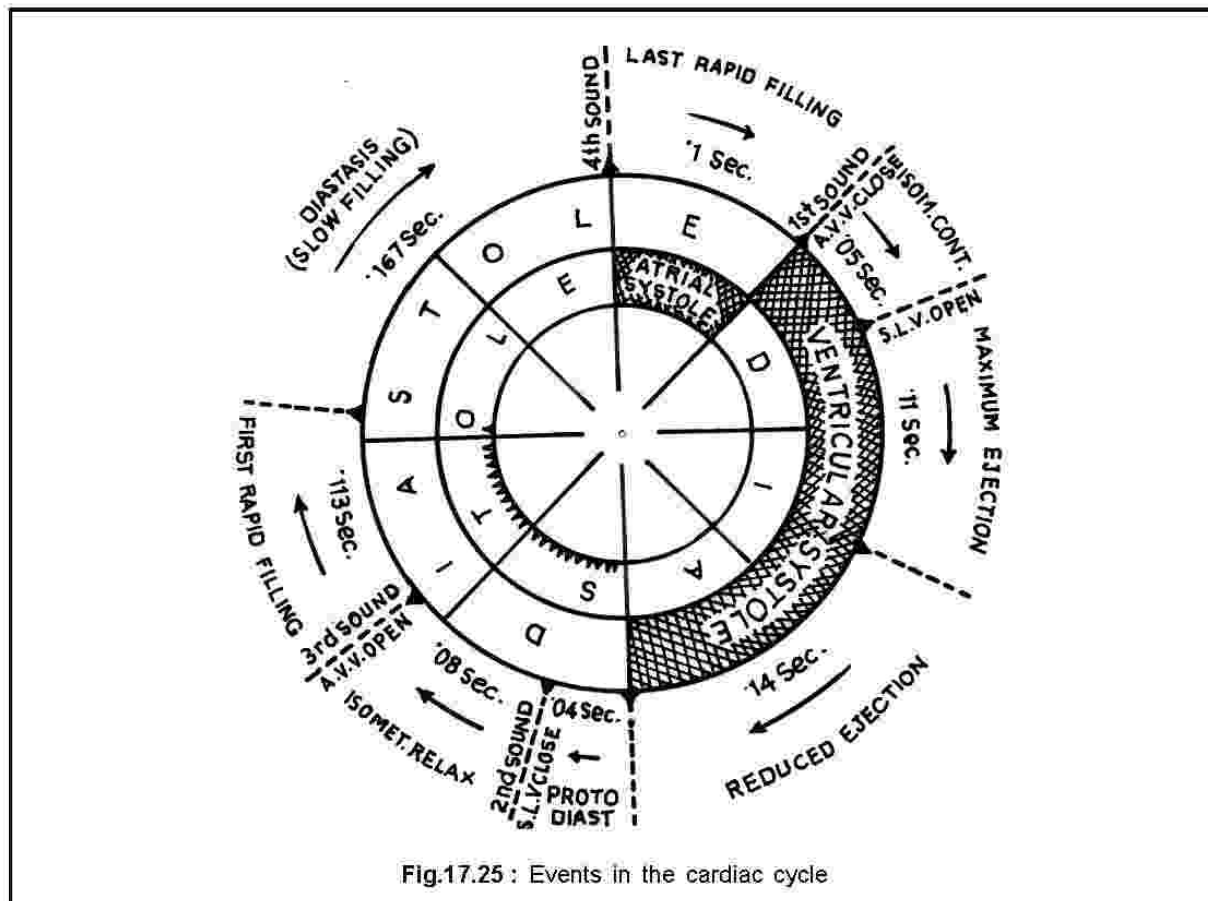

rings, divided into eight equal parts (Fig.17.25). The inner ring represents the events in the atria, while the outer in the ventricles. Each of the equal parts represents a time lapse of 0.1 sec. The atrial systole spans only one division (0.1 sec), while the atrial diastole the rest seven (0.7 sec). The ventricular systole covers three divisions (0.3 sec), while the diastole five (0.5 sec).

### 17.7.1. Atrial systole and diastole :

The pacemaker is situated in the right atrium and the myocardial wave of contraction initiates from the right atrium and then spreads to the left atrium. However, it is explained that two atria contract almost simultaneously. The force of contraction is stronger in the first half than in the second half. The buildup of pressure causes the atrio-ventricular valves to open and blood to flow from the atria to the respective ventricles. It has been estimated that 80% of the ventricles are filled with blood even before the atria contract. Atrial systole adds the rest 20% to the **end-diastolic volume**, which is the final volume of blood in the ventricles. Following the atrial systole, the atrial diastole (0.7 sec) commences. During this period, the right and left atria relax and receive blood from the venacavae and pulmonary veins, respectively. At the end of this phase, atrial systole is repeated.

### 17.7.2. Ventricular systole and diastole :

At the end of atrial systole, the ventricular systole commences. **As evident from the Fig.17.25, the two events do not overlap.** The ventricular systole covers a lapse of 0.3 sec. This is followed by ventricular diastole (0.5 sec). At the onset of ventricular systole, the atrio-ventricular (tricuspid and bicuspid) valves are shut, producing the **first heart sound**.

The inter-ventricular pressure builds up to open the semilunar valves, guarding the aorta and pulmonary artery. Consequently, the semilunar valves open a little later than the closure of the AV valves. Thus, at the beginning of the ventricular systole, the ventricles contract as closed cavities for a brief period. This period is known as **isovolumetric contraction period** (0.05 sec). At the end of this period, the semilunar valves open and the blood from the right and left ventricles are ejected into pulmonary artery and aorta, respectively. Ventricular systole ejects about two-third of the blood the ventricles contain. This amount of blood is known as the **stroke volume**. One-third of the initial amount is left in the ventricles as the **end-systolic volume**. During the first part of this period, there is a rapid outflow. Therefore, this period is termed as **rapid ejection period**. The outflow slows down towards the last part and this period is termed as **reduced ejection period**. The ventricular diastole, represented by five divisions, follows ventricular systole. With the relaxation of the ventricles, the intra-ventricular pressure falls. This causes the semilunar valves to shut, producing the **second heart sound**. Thus, **the onset of the ventricular systole is marked by the first sound and its termination by the second sound**.

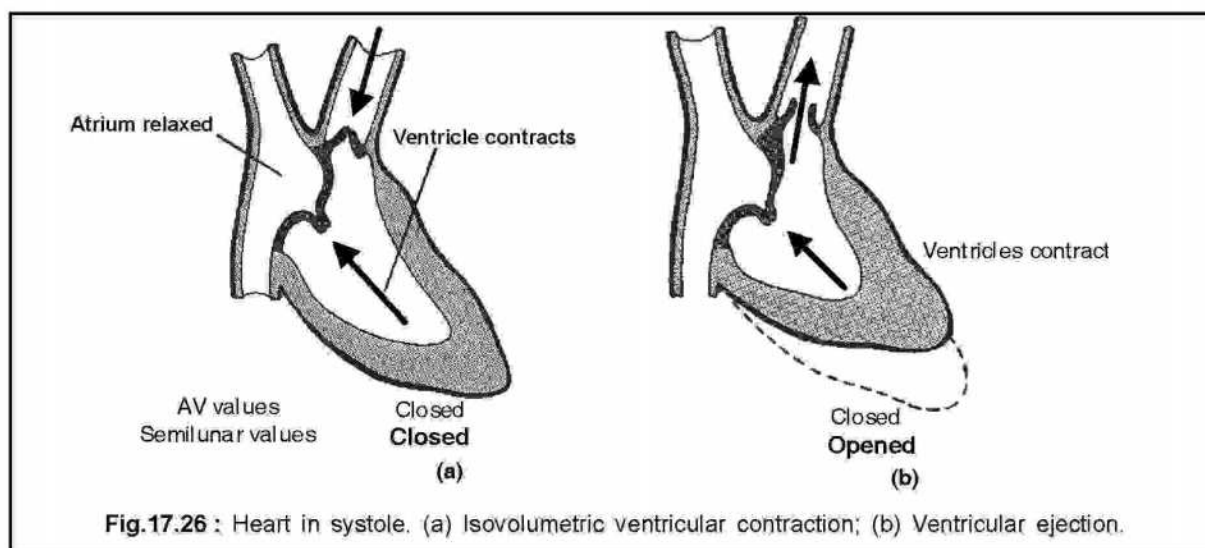

*The blood contributed by the contraction of the atria does not seem to be vital for life. Old age people, who have a condition, in which atria fail to contract, appear to have the same average longevity like those having normally functioning atria. This condition is known as **atrial fibrillation**. However, such people are fatigued more easily during exercise.*

Comparison of two rings in the Fig. 7.15 indicates that the last division of the ventricular diastole overlaps with the atrial systole and further, the first four divisions of the ventricular diastole overlap with the last four divisions of the atrial diastole. From these observations, it is said that **the diastole of the atria and ventricles will always partly overlap**. Alternately speaking, **both the chambers are in diastole or the entire heart is in diastole (0.4 sec)**.

As stated above that the second sound occurs exactly at the end of ventricular systole is not true. The semilunar valves will actually shut, when the intra-ventricular pressure falls below the intra-aortic pressure. Indeed there is a gap between the onset of ventricular diastole and closure of the semilunar valves. This period is known as **protodiastolic period (0.04 sec)**.

Although the semilunar valves have closed, the atrio-ventricular valves have not opened. These valves will open only when the intra-ventricular pressure goes below that of the atria. Consequently, there will be a brief period, during which both the valves remain closed and the ventricles are relaxing as closed cavities. This time lapse is known as **isovolumetric relaxation period (0.08 sec)**. As soon as the A-V valves open, blood rushes from the atria into the ventricles and the ventricular filling begins. The first part of this period is known as **first rapid filling phase**. Due to a rapid rush of the blood, a **third heart sound** is produced. In the middle part the rate slows down. This phase is known as **diastasis** or **slow inflow phase**. The ventricular diastole overlaps with atrial systole in the last division. This contributes towards the **last rapid filling phase**. It is responsible for the **fourth heart sound**.

#### Murmurs :

**Heart murmurs are abnormal heart sounds, produced due to abnormal patterns of blood flow due to defective valves.** Defective valves may be congenital or may result due to an auto-immune disorder, **rheumatic endocarditis**. Small defects do not seriously compromise with the pumping of the blood. However, in larger defects, like **mitral stenosis**, mitral valves become calcified impairing the blood flow from the left atrium to the left ventricle. Murmurs can also be produced due to septal defects.

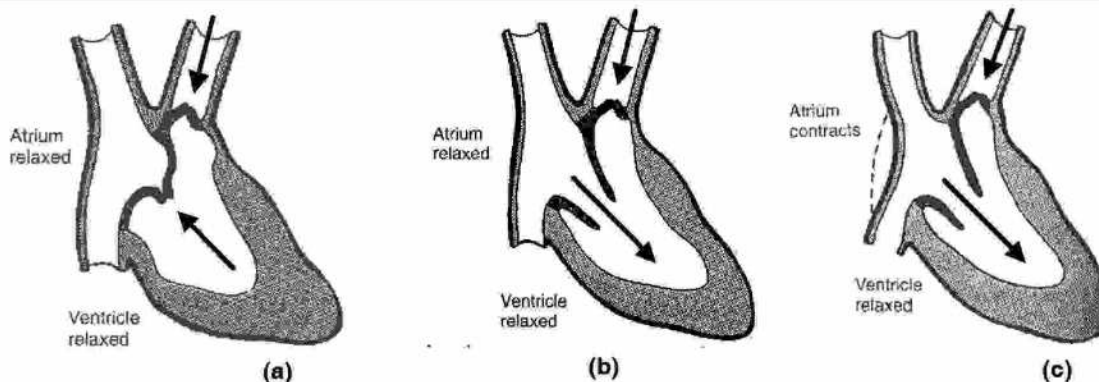

**Fig.17.27 :** The heart in diastole. (a) Isovolumetric relaxation; (b) & (c) Ventricular filling.

**Blood Pressure :**

When the left ventricle contracts, the semilunar valves of the aorta open and the blood is rapidly ejected into the aorta. The pressure in the left ventricle and the aorta rises to about 120 mm Hg. This pressure is known as the **systolic blood pressure**. Following this, the ventricles relax and the pressure in the left ventricle falls below the pressure of the aorta. The semilunar valves are shut producing the second heart sound. The pressure in the aorta falls to 80 mm Hg. This pressure is known as the **diastolic pressure**. The blood pressure of a healthy human being is denoted by the systolic pressure upon the diastolic pressure i.e. 120 mm Hg / 80 mm Hg. An instrument used to measure the blood pressure is known as **sphygmomanometer**.

Similar events occur in the right ventricle and pulmonary circulation. **The maximum pressure produced at ventricular systole is 25 mm Hg, which then falls to 8 mm Hg.**

The blood pressure is affected by three parameters: cardiac rate; stroke volume; and total peripheral resistance by vasoconstriction. The arterial blood pressure is directly proportional to the product of cardiac output and total peripheral resistance.

Thus,

$$\text{Arterial Blood Pressure} = \text{A Cardiac output} \times \text{Total peripheral resistance}$$

**Measurement of blood pressure :**

**Stephen Hales (1677-1761)** inserted canula into an artery of the horse. The blood rose to a height and the blood column bounced between two points, the systolic and diastolic pressures. **The modern method of measuring the blood pressure is indirect, known as auscultatory.** The instrument is known as **sphygmomanometer**. In this method, an inflatable rubber bag is wrapped around the upper arm and the stethoscope is applied over the brachial artery. The artery is silent before the inflation of the bag. The bag is inflated by forcing air into it by a rubber pump. As the air is pumped, the mercury column rises and at a point, the blood flow in the artery is stopped by complete constriction and the artery becomes silent. Air from the bag is released slowly by loosening a screw in the pump. When the pressure of the air falls below that of the inflowing arterial blood, there is a sound. This sound is known as the **sound of Korotkoff**. Concurrent with the release of air, there is a fall in the mercury column. **The pressure in mm Hg in the mercury column is recorded at the first sound as the systolic pressure.** As the air is released and the mercury column falls, the intensity of the sound fades and at a point, the last sound of Korotkoff is heard and no more thereafter. **This height of the mercury column at the last sound is recorded as the diastolic pressure in mm Hg.** The average blood pressure in the systemic circulation in human is 120/80 mm Hg. The average pressure in the pulmonary arterial circulation is 22.8 mm Hg.

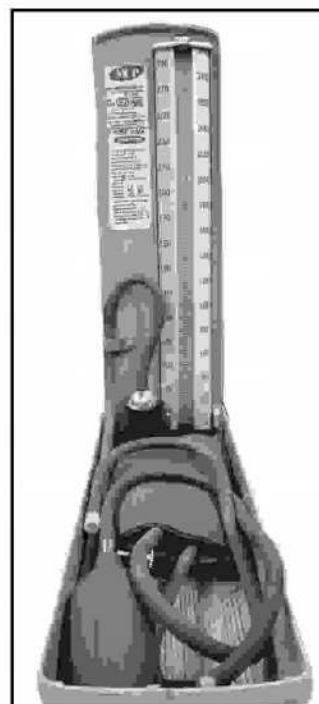

A sphygmomanometer for measuring the blood pressure.

**Pulse:**

The blood is forced from the left ventricle into the aorta during the systole. The systole creates a pressure wave that travels along the arteries. The wave stretches the arterial wall as it travels along. The stretching or expansion is palpable i.e. it can be felt or touched as pulse. The rate of movement of the pulse is 4m/sec in the aorta; 8m/sec in large arteries; and 16 m/sec in small arteries. The strength of the pulse is determined by the pulse pressure and bears little relation to the average blood pressure. **The difference between the systolic pressure and diastolic pressure is known as the pulse pressure.** Thus,

$$\text{The Pulse pressure} = 120 \text{ mm Hg} - 80 \text{ mm Hg} = 40 \text{ mm Hg}$$

The mean arterial pressure is computed from the pulse pressure, like:

$$\begin{aligned} \text{Mean arterial pressure} &= \text{Diastolic pressure} + 1/3 \text{ Pulse pressure} \\ &= 80 + 40/3 = 93 \text{ mm Hg.} \end{aligned}$$

**17.8. CARDIAC OUTPUT :**

Cardiac output is the volume of blood pumped by each ventricle per minute. It is given by the product of **stroke volume** (mL/beat) and **cardiac rate** (beats/min). The average cardiac rate in an adult human is 75 beats / min and the stroke volume i.e. the volume of blood pumped per beat by each ventricle is 70-80 mL / beat (75 mL/beat on an average).

Thus, **Cardiac output** = 75 mL/min  $\times$  75 beats / min = 5625 mL  $\approx$  5.5 L (approximately)

The total blood volume also averages about 5.5 L. This means that each ventricle pumps an equivalent of the total blood volume each min. Thus, when the cardiac output increases, the arterial blood pressure also increases proportionately.

**17.9. ELECTROCARDIOGRAM (ECG) (See the figure on the side) :**

(ECG) is a record of the electrical events in the heart on a piece of moving paper. The body fluid is a good conductor of electricity and therefore, the fluctuations in the potential of myocardial cells are recorded by placing electrodes externally. ECG may be recorded by using a single electrode, known as **active** or **exploring electrode (unipolar)** or by using **two active electrodes (bipolar)**.

As the recording shows, there are three deflections. The first deflection, called the P-wave, corresponds to the current flowing during **atrial depolarization**. The second deflection is the QRS complex, occurring approximately after 0.15 sec later than atrial depolarization. It is the result of **ventricular depolarization**. The final deflection is the T wave. It is the result of **ventricular repolarization**. Any deviation from the normal ECG points towards an abnormal functioning of the heart.

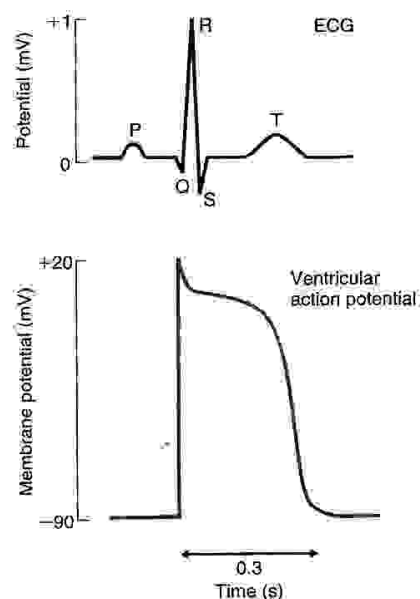

### Correlation of ECG with heart sounds (See figure on the side):

The depolarization of the ventricles is marked by the QRS wave. The QRS wave is seen at the beginning of ventricular systole. The rise in the intraventricular pressure causes the AV valves to close, so that the first heart sound (lub) is produced. It is produced immediately after the QRS wave. Repolarization of the ventricles is indicated by the T wave. It is synonymous with diastole. The fall in the intraventricular pressure causes the pulmonary and aortic semilunar valves to close, producing the second heart sound (dup).

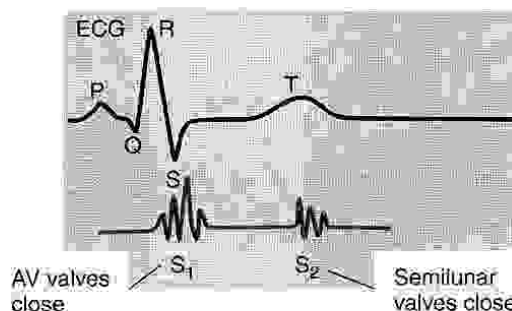

### 17.10. CLOSED CIRCULATION :

Most multicellular non-chordates and all chordates possess a circulatory system, in which the blood circulates in closed blood vessels. This is known as closed circulation. Blood is separated completely from other body fluids. A pulsatile heart is connected to two types of blood vessels :

1. **Vessels that carry blood away from the heart :** These vessels are called **efferent vessels** or **arteries**. All arteries, except pulmonary arteries, carry oxygenated blood to the tissues and organs of the body
2. **Vessels that carry blood towards the heart :** These vessels are called **afferent vessels** or **veins**. All veins, except the pulmonary veins carry deoxygenated blood from different tissues and organs to the heart.

Closed circulation is of two types: **single circulation** and **double circulation**.

#### 17.10.1. Single circulation :

As discovered by the British physiologist, **William Harvey (1628)**, the cardio-vascular system forms a circle. The blood pumped out of the heart through one set of vessels (arteries) returns to the heart through a different set of vessels (veins). In single circulation, as exemplified by **cyclostomes** and **fishes**, there is a single circuit of blood flow i.e. the venous blood flowing through the heart returns to the heart as the venous blood again (Fig.17.28). The heart does not contain arterial blood at any point of time.

The heart of cyclostomes and fishes is two-chambered, consisting of an atrium and a ventricle. The deoxygenated blood from all parts of the body is collected through large veins and is drained into the heart. This blood then is carried to the gills for oxygenation and following oxygenation, the blood is supplied to all parts of the body, bypassing the heart. The deoxygenated blood from the tissues and organs is again collected by veins, which is emptied into the heart, thus completing the circuit. The heart, thus, contains deoxygenated blood only and therefore, is known as a **venous heart**.

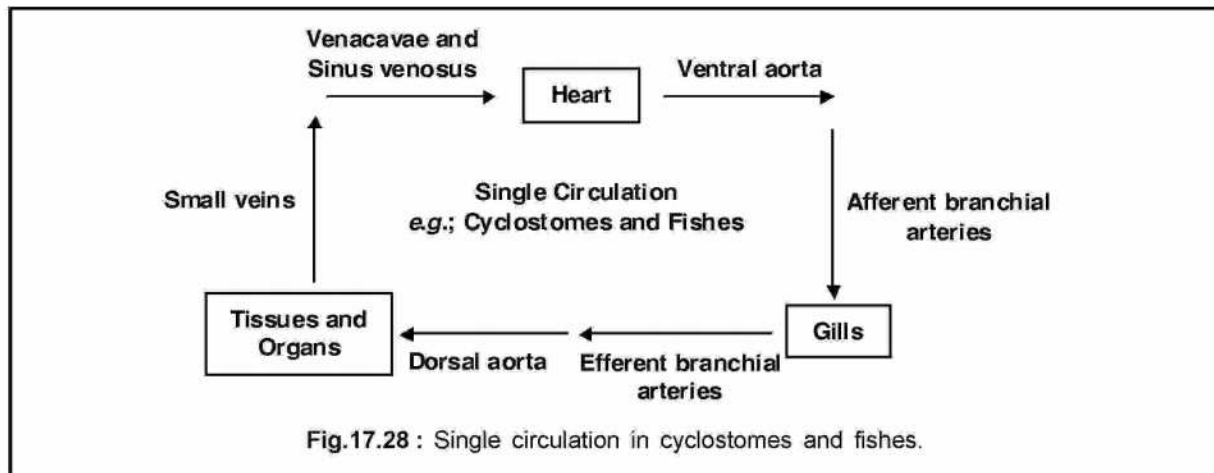

### 17.10.2. Double circulation :

The heart of vertebrates, above the grade of fishes, is longitudinally divided into two functional halves. Each half contains two chambers: an atrium and a ventricle. An atrium empties the blood into the ventricle of its side only. There is no direct communication between the two atria or the two ventricles. There are two circuits of circulation, such as **pulmonary circulation** and **systemic circulation**. The two circuits are completely separated from each other (Fig. 17.29).

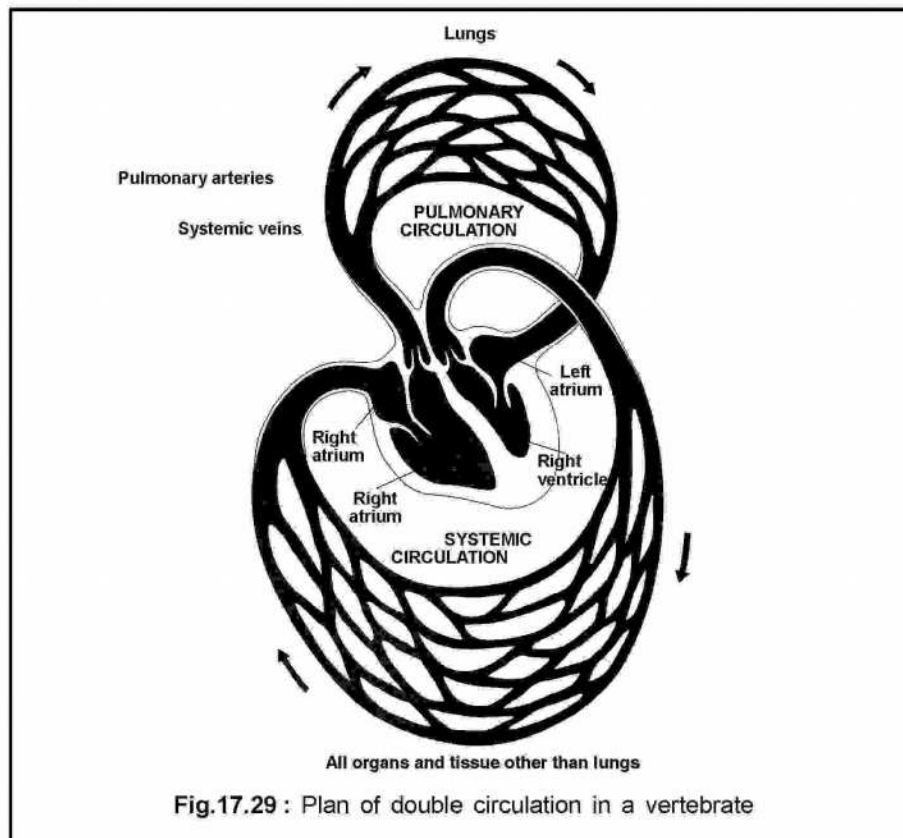



**(a) Pulmonary circulation:** The deoxygenated blood from the right ventricle is pumped into the pulmonary arteries. The pulmonary arteries break up into arterioles and then into capillaries in the lung tissue. These capillaries join to form venules and the venules into pulmonary veins, which return the oxygenated blood to the left atrium. Thus, the pulmonary circulation circuit is complete.

**(b) Systemic circulation:** The left atrium pumps the oxygenated blood into the left ventricle and by the contraction of the left ventricle; this oxygenated blood is pumped into the aorta. The aorta breaks up into arteries, which supply oxygenated blood to all tissues and organs of the body. The arteries break up into arterioles and then into capillaries. The capillaries join forming venules and the venules into veins. All the veins join forming the superior and inferior venacavae. The venacavae finally empty the blood into the right atrium. Thus, the systemic circulation circuit is complete.

### 17.11. REGULATION OF HEART :

Various intrinsic, neural, and hormonal factors act to influence the rhythm control and impulse conduction within the heart. The rhythmic control of the cardiac cycle and its accompanying heart beat relies on the regulation of impulses generated and conducted within the heart. Regulation of the cardiac cycle is also achieved via the autonomic nervous system. The sympathetic and parasympathetic divisions of the autonomic system regulate heart rhythm by affecting the same intrinsic impulse conducting mechanisms that lie within the heart in opposing ways.

Cardiac muscle is self-contraction because it is capable of generating a spontaneous electrochemical signal as it contracts. This signal induces surrounding cardiac muscle tissue to contract and a wave-like contraction of the heart can result from the initial contraction of a few localized cardiac cells.

The cardiac cycle describes the normal rhythmic series of cardiac muscular contractions. The cardiac cycle can be subdivided into the systolic and diastolic phases. Systole occurs when the ventricles of the heart contract and diastole occurs between ventricular contractions when the right and left ventricles relax and fill. The sinoatrial node (S-A node) and atrioventricular node (AV node) of the heart act as pacemakers of the cardiac cycle.

The contractile systolic phase begins with a localized contraction of specialized cardiac muscle fibers within the sino-atrial node. The S-A node is composed of nodal tissue that contains a mixture of muscle and neural cell properties. The contraction of these fibers generates an electrical signal that then propagates throughout the surrounding cardiac muscle tissue. In a contractile wave originating at the S-A node, the right atrium muscle contracts (forcing blood into the right ventricle) and then the left atrium contracts (forcing blood into the left ventricle).

Intrinsic regulation is achieved by delaying the contractile signal at the atrioventricular node. This delay also allows the complete contraction of the atria so that the ventricles receive

the minimum amount of blood to make their own contractions efficient. A specialized type of neuro-muscular cells, named Purkinje cells, form a system of fibers that covers the heart and which conveys the contractile signal from S-A node (which is also a part of the Purkinje system or subendocardial plexus). Because the Purkinje fibers are slower in passing electrical signals (action potentials) than are neural fibers, the delay allows the atria to finish their contractions prior to ventricular contractions. The signal delay by the AV node lasts about a tenth (0.1) of a second.

The contractile signal then continues to spread across the ventricles via the Purkinje system. The signal travels away from the AV node via the bundle of His before it divides into left and right bundle branches that travel down their respective ventricles.

Extrinsic control of the heart rate and rhythm is achieved via autonomic nervous system (ANS) impulses (regulated by the medulla oblongata) and specific hormones that alter the contractile and or conductive properties of heart muscle. ANS sympathetic stimulation via the cervical sympathetic chain ganglia acts to increase heart rate and increase the force of atrial and ventricular contractions. In contrast, parasympathetic stimulation via the vagal nerve slows the heart rate and decreases the vigor of atrial and ventricular contractions. Sympathetic stimulation also increases the conduction velocity of cardiac muscle fibers. Parasympathetic stimulation decreases conduction velocity.

The regulation in impulse conduction results from the fact that parasympathetic fibers utilize acetylcholine, a neurotransmitter hormone that alters the transmission of an action potential by altering membrane permeability to specific ions (e.g., potassium ions  $[K^+]$ ). In contrast, sympathetic postganglionic neurons secrete the neurotransmitter norepinephrine that alters membrane permeability to sodium ( $Na^+$ ) and calcium ions ( $Ca^{2+}$ ).

The ion permeability changes result in parasympathetic induced hypopolarization and sympathetic induced hyperpolarization.

Additional hormonal control is achieved principally by the adrenal glands (specifically the adrenal medulla) that release both epinephrine and norepinephrine into the blood when stimulated by the sympathetic nervous system. As part of the fight or flight reflex, these hormones increase heart rate and the volume of blood ejected during the cardiac cycle.

The electrical events associated with the cardiac cycle are measured with an electrocardiogram (ECG). Disruptions in the impulse conduction system of the heart result in arrhythmias.

Variations in the electrical system can lead to serious, even dangerous, consequences. When that occurs an artificial electrical stimulator, called a pacemaker, must be implanted to take over regulation of the heartbeat. The small pacemaker can be implanted under the skin near the shoulder and long wires from it are fed into the heart and implanted in the heart

muscle. The pacemaker can be regulated for the number of heartbeats it will stimulate per minute. Newer pacemakers can detect the need for increased heart rate when the individual is under exertion or stress and will respond.

## 17.12. DISORDERS OF CIRCULATORY SYSTEM :

### 17.12.1. Hypertension :

Hypertension is a sustained blood pressure in excess of the normal range. Hypertension that appears due to diseases is known as **secondary hypertension**. It accounts for only 5%. In over 90% of patients, the cause of hypertension is not known. This type is known as **essential hypertension**. An increased **total peripheral resistance** is the main cause of this condition. Some causes of this type of hypertension are outlined below.

**Table - 17.4**  
**Blood Pressure Groups in Adults**

Group	Systolic pressure (mm Hg)	Diastolic pressure (mm Hg)
Normal	120	80
Prehypertension	120-139	80-89
Hypertension (Stage I)	140-159	90-99
Hypertension (Stage II)	160 and above	100 and above

1. It is believed that the endothelium of the arteries secretes decreased levels of **nitric oxide (NO)**, a **vasodilator** and increased levels of **endothelin**, a **vasoconstrictor**.
2. Elevated levels of **renin**, a **kidney enzyme**, which catalyzes the formation of **angiotensin II** is another cause of hypertension. It stimulates **aldosterone** secretion, which promotes salt and water retention by the kidneys, consequently increasing blood volume.
3. High stress, resulting from **sympathetic stimulation**, and high salt intake help in the progression of hypertension.
4. **Arteriosclerosis** leads to the occlusion of the arterial lumen and hence, increases the total peripheral resistance. This leads to the development of hypertension.
5. Finally, dysfunction in the kidneys may lead to a sustained blood pressure and hypertension. The malfunctioning kidneys fail to eliminate salt and water and thereby, increase blood volume and blood pressure.

**Effects of hypertension :** Hypertension is the cause of many cardio-vascular diseases. Some of these are enlisted below.

1. A sustained blood pressure may result in endothelial damage in the blood vessels of vital organs. This may lead to the formation of a thrombus or clot and this in turn may impair normal blood supply. A prolongation of this may damage the organ.
2. High blood pressure is caused by peripheral resistance and this increases the pressure on the ventricles to eject blood. A sustained action of the ventricles in this manner leads to a progressive weakening of the ventricular muscle. It finally leads to a congestive heart failure.
3. High pressure may damage the cerebral blood vessels, which may lead to cerebrovascular accident or stroke.
4. Finally, hypertension contributes to the development of atherosclerosis, which leads to several heart diseases.

#### Treatment :

(a) **Change in the life style** : The following changes in the life style are very much essential in keeping the blood pressure within its limits.

1. Getting rid of smoking habit
2. Reducing consumption of alcohol
3. Programmed exercise and reduction in the intake of sodium
4. Eating food that is rich in potassium and supplementing the food with  $\text{Ca}^{2+}$

(b) **Drug therapy** : If a change in the lifestyle does not work, drugs are recommended. However drugs may be taken with the advice of a qualified physician.

1. Diuretic drugs increase urine volume, thus decreasing blood volume and blood pressure.
2. Drugs that block  $\beta_1$ -adrenergic receptors (e.g.; **Atenolol**)
3. Angiotensin converting enzyme (ACE) inhibitor inhibits the conversion of angiotensin I to angiotensin II. Angiotensin II is a vasoconstrictor and hence increases the blood volume and pressure (e.g.; **Captopril**; **Enalapril**). Angiotensin receptor blockers, unlike ACE inhibitor, allow angiotensin II to be formed, but inhibit the binding of angiotensin II to its receptor (e.g.; **Losartan**).

#### 17.12.2. Atherosclerosis :

It is a disease of large and intermediate size arteries in which fatty substances such as cholesterol is deposited on their inner wall. Cholesterol molecules conjugate with plasma proteins and circulate as lipoproteins.

These lipoproteins associate with the membrane of endothelial cells. The trapped molecules trigger the endothelial cells to synthesize cell adhesion molecules, specific for

monocytes. The attached monocytes burrow through the endothelial wall and lie in the smooth muscular layer of the artery (tunica media), where they transform into macrophages. They engulf the associated lipid and become gorged. Such macrophages are known as **foam cells**. Chemotactic factors, released by foam cells recruit more leucocytes perpetuating the state of inflammation. The deposited lipid and macrophages form plaques, known as **atherosclerotic** or **atheromatous plaques** [Fig.17.30 (a) and (b)]. The deposited lipids and trapped macrophages are surrounded by smooth muscle cells, which later undergo calcification. Consequently, the plaque hardens and occludes the arterial lumen. The incidence of atherosclerosis is correlated with the concentration of circulating **low density lipoprotein (LDL)**, often referred to as **bad cholesterol**. It is also caused by smoking and hypertension. Atherosclerosis is less likely in individuals, who maintain low level of cholesterol in their blood and who have high levels of **high density lipoproteins [HDLs (good cholesterol)]** in their blood. **Women have a higher level of HDL in their blood and therefore, have a lower risk of getting heart diseases than men.**

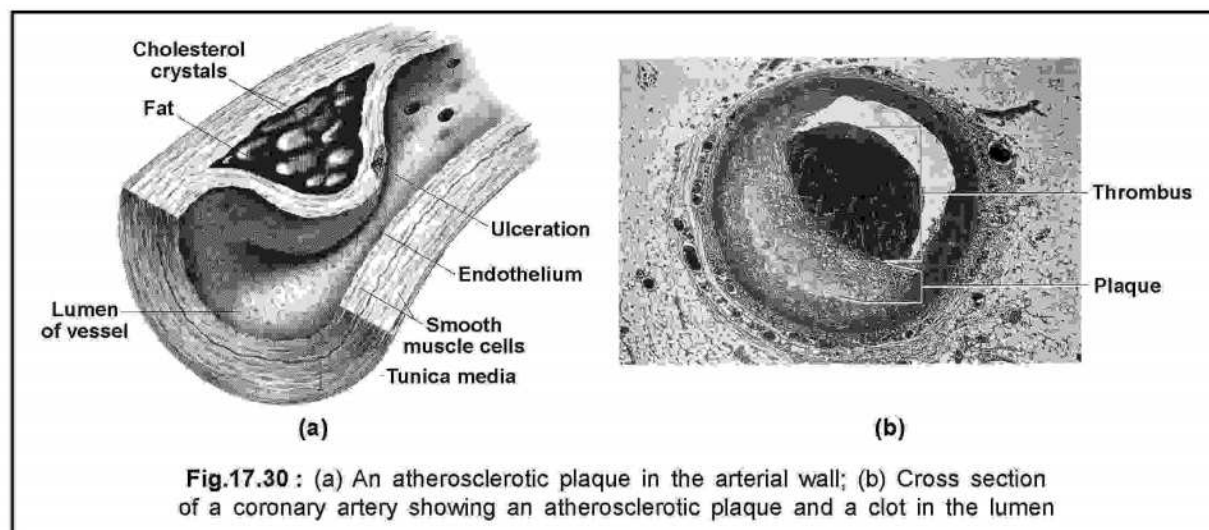

**Fig.17.30 :** (a) An atherosclerotic plaque in the arterial wall; (b) Cross section of a coronary artery showing an atherosclerotic plaque and a clot in the lumen

**Cholesterol, plasma lipoproteins and atherosclerosis :** Another major cause of atherosclerosis is the **lack of LDL receptors** or presence of defective receptors on the membrane of liver cells. This situation elevates the level of plasma LDL concentration, which leads to atherosclerosis. This is an **autosomal dominant disorder**, known as **familial hypercholesterolemia**. Normal liver cells do have specific membrane-bound receptors for circulating LDLs. The LDLs bind to their receptors in a species-specific manner and the complexes are engulfed by **receptor-mediated endocytosis**. The cholesterol molecules are released from the LDLs and metabolized. However a mutation in the gene, expressing LDL receptor, causes the formation of a different receptor, which does not bind to LDLs. Consequently, the concentration of circulating LDLs rises leading to atherosclerosis and hence to heart diseases. An excessive rise in the level of plasma cholesterol may result in the deposition of cholesterol in the skin and tendons as yellow nodules, known as **xanthomas**.

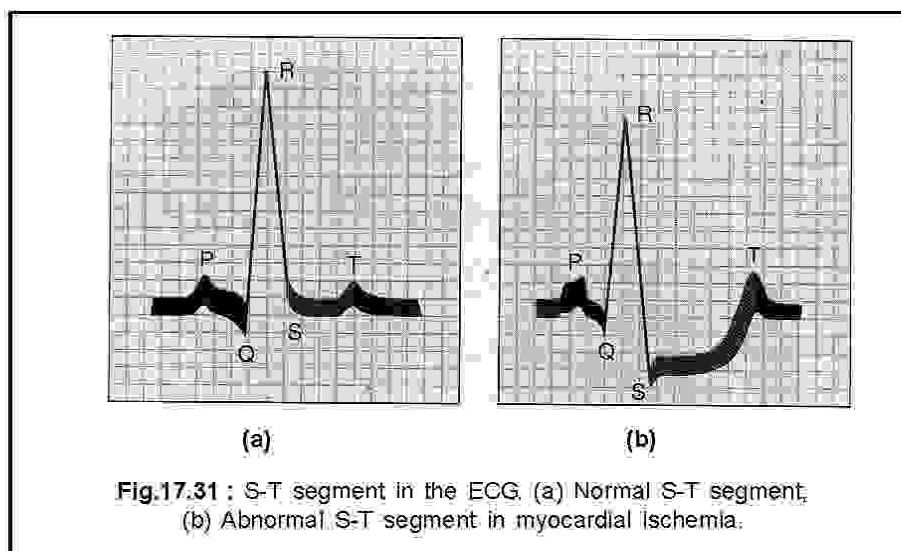

### Effects of atherosclerosis :

Atherosclerosis leads to heart diseases, known as **ischemic heart diseases**. When a tissue is deprived of oxygen supply due to inadequate blood flow, it is known as **ischemic**. The most common cause of myocardial ischemia is atherosclerosis of coronary arteries. Myocardial ischemia is associated with increased formation of blood lactic acid by anaerobic respiration. This causes an unbearable pain, known as **angina pectoris**, in the sub-sternal region of the left side (left shoulder and arm). Such people, with angina, take **nitroglycerine** to get a relief from ischemia and pain. It causes **vasodilation**, thus, improving blood supply to the heart.

***Statins** is a class of drugs, which inhibits the enzyme, **HMG-coenzyme A reductase**. This enzyme catalyzes a step in the biosynthesis of cholesterol in the liver cells. Taking the drug, reduces the incidence of atherosclerosis and hence heart diseases.*

If ischemia and anaerobic respiration prolong, the myocardial cells, deprived of oxygen may die. A sudden irreversible injury of this type is referred to as **myocardial infarction** or **heart attack**. The damaged cells can not be repaired nor can these be regenerated. It is detected by the changing pattern of the S-T segment of the electrocardiogram [Fig.17.31 (b)]. The normal pattern is depicted in Fig.17.31 (a).

The diagnosis of myocardial infarction is made by measuring the plasma concentrations of some enzymes, **creatine phosphokinase (CPK)** and **lactate dehydrogenase (LDH)**. For example, the CPK level increases within 3-6 hr after the onset of the symptoms and returns to normal after 3 days. Plasma LDH level reaches a peak within 48-72 hr after onset of the symptoms and remains as such for 11 days. Besides, the plasma concentrations of troponin T and I (muscle proteins) are also elevated. All these may lead to a stoppage of blood supply to the brain which is known as **stroke**.



### DIFFERENCES BETWEEN TWO WORDS IN PAIRS OF WORDS

#### Open Circulatory System

1. The blood flows through large open spaces and channels among the tissues, called **lacunae** and **sinuses**.
2. Tissues are in direct contact with the blood.
3. Blood flow is very slow.
4. Exchange of respiratory gases and nutrients occur directly between the blood and the tissues.
5. The blood flow can not be regulated.  
[e.g.; Arthropods (crustaceans and insects)]

#### Single Circulation

1. The blood circulates once through the heart *i.e.*, there is a single circuit of circulation.
2. The heart contains **venous blood** only at any point of time.
3. The heart is two chambered with an atrium and a ventricle.  
(e.g.; Cyclostomes and fishes)

#### Blood

1. Blood is a body fluid that circulates in closed blood vessels.
2. It is red in colour due to the presence of an iron containing respiratory pigment, haemoglobin in erythrocytes.
3. All three types of corpuscles, namely erythrocytes (RBC); leucocytes (WBC); and thrombocytes (platelets) are present.
4. The digestion end products, such as monosaccharides and aminoacids are absorbed into the blood.

#### Closed Circulatory System

1. The blood flows through a closed space, constituted by the heart and walled blood vessels.
2. The blood does not come in direct contact with the tissues.
3. Blood flow is rapid.
4. Respiratory gases and nutrients diffuse through the capillary walls into the tissue fluid, from where they pass on to the tissues.
5. The blood flow is regulated  
(e.g.; Annelids; molluscs; echinoderms; and all chordates)

#### Double Circulation

1. The blood circulates twice through the heart *i.e.*, there are two circuits of circulation namely pulmonary and systemic.
2. The heart contains both **venous** and **arterial blood**.
3. The heart is 3-4 chambered with two auricles and a single ventricle or two atria and two ventricles.  
(e.g.; All tetrapods)

#### Lymph

1. Lymph is a tissue fluid that enters into lymphatic vessels and is returned into the blood vascular system through the venous blood.
2. It is colourless due to the absence of erythrocytes (RBC) and hence haemoglobin.
3. Only lymphocytes are present.
4. The digestion end products of lipids, such as fatty acids are absorbed into the lymph.



**Plasma**

1. Plasma is the fluid part of the blood, which contains all kinds of organic and inorganic solutes in dissolved state.
2. It contains the fibrinogen (the coagulation protein) in a soluble state.

**Erythrocytes (RBCs)**

1. Red in colour due to the presence of iron-containing haemoglobin.
2. Most numerous in the blood i.e. 4.5 – 5.5 millions / mm<sup>3</sup> of blood.
3. Anucleate disc-like cells.
4. Can't infiltrate through capillary walls.
5. Confined to blood vessels.
6. Carry oxygen from the lungs to the tissues.

**Artery**

1. Has a relatively thicker wall and a smaller lumen.
2. The wall is made up of three layers: outer **tunica adventitia** or **externa**; middle **tunica media**; and inner **tunica intima**.
3. Tunica media (smooth muscle layer) is thicker.
4. Transport blood away from the heart to the lungs and tissues.
5. Valves are absent.
6. Blood pressure is higher.
7. Generally lie deep-seated in the body

**Serum**

1. It is a clear fluid part of the blood that oozes out from an wound following the clot formation.
2. It does not contain fibrinogen i.e. the soluble fibrinogen has precipitated out as fibrin mesh following a clot formation.

**Leucocytes (WBCs)**

1. Colourless due to the absence of haemoglobin.
2. Least numerous in the blood i.e. 8, 000 – 12, 000 / mm<sup>3</sup> of blood.
3. Nucleated cells.
4. Can infiltrate through the capillary walls by **diapedesis**.
5. Present in the blood as well as the tissue fluid.
6. Evoke an immune response and thus defends the body from external aggression.

**Vein**

1. Has a relatively thinner wall and a larger lumen.
2. The wall is made up of three layers: outer **tunica adventitia** or **externa**; **tunica media**; and **tunica intima**.
3. Tunica media is thinner.
4. Transport blood to the heart from the lungs and tissues.
5. Valves are present periodically.
6. Blood pressure is lower.
7. Generally superficially seated.

### Neurogenic Heart

1. The heart beat is initiated by a **nerve ganglion**, situated near the heart.
2. The impulse of contraction originates from the nerve ganglion.
3. The heart normally stops beating after removal from the body.

### Sino-Atria (SA) Node

1. The SA node is situated in the wall of the right atrium between the openings of superior and inferior venacavae.
2. It initiates the heart beat by generating an action potential, which spreads to the entire atrial wall.
3. It generates impulses at the rate of 75 times per min.
4. It is known as the **pace maker**.

### Blood Group 'O' (Universal donor)

1. A person with O blood group can donate blood to person of any blood group.
2. The serum contains both **anti A and anti B antibodies** or **agglutinins**.
3. The erythrocyte membranes do not contain A or B antigens or agglutinogens.

### Myogenic Heart

1. The heart beat is initiated by a patch of modified cardiac muscle fibers, constituting a **pacemaker**.
2. The impulse of contraction originates from the pacemaker and is transmitted to different parts in a rhythmic manner.
3. The heart continues to beat for a variable time period following its removal from the body, subject to the condition that it is perfused with normal saline solution.

### Atrio-Ventricular (AV) Node

1. The AV node is situated in the wall of the right atrium at the base of the inter-atrial septum.
2. It is stimulated by the SA node and transmits the waves of excitation to the bundle of His.
3. It generates impulses at the rate of 60 times per min.
4. It is known as the **pace setter**.

### Blood Group 'AB' (Universal recipient)

1. A person with AB blood group can receive blood from a person with any blood group.
  2. Serum does not contain anti A and anti B antibodies or agglutinins.
  3. The erythrocyte membranes contain both A and B antigens or agglutinogens.
-

**SAMPLE QUESTIONS****GROUP - A****(Objective-type Questions)****1. Choose the correct answer:**

- (i) Double circulation is exhibited by:  
(a) Rohu (c) Scoliodon  
(b) Cockroach (d) Frog
- (ii) Which of the following is not a granulocyte:  
(a) Neutrophil (c) Eosinophil  
(b) Monocyte (d) Basophil
- (iii) Serum does not contain:  
(a) Fibrin (c) Globulin  
(b) Albumin (d) Bilirubin
- (iv) Drumstick, representing sex chromatin is present in:  
(a) Eosinophil (c) Lymphocyte  
(b) Neutrophil (d) Monocyte
- (v) Adult haemoglobin (HbA) contains:  
(a) Gamma globin chains (c) Epsilon globin chains  
(b) Beta globin chains (d) Zeta globin chains
- (vi) An amino acid substitution in the beta globin chain causes:  
(a) Haemolytic anemia (c) Microcytic anemia  
(b) Pernicious anemia (d) Sickle cell anemia
- (vii) The presence of a large number of immature leucocytes in the circulation is indicative of :  
(a) Leucocytosis (c) Leucopenia  
(b) Leukemia (d) Leucomorphosis
- (viii) Find the incorrect pair:  
(a) Neutrophil – Phagocyte (c) Lymphocyte – Immunoglobulin  
(b) Eosinophil – Histamine (d) Monocyte – Macrophage
- (ix) Open circulation is exhibited by:  
(a) Annelids (c) Arthropods  
(b) Vertebrates (d) Protochordates
- (x) Myogenic heart is present in:  
(a) Annelids (c) Molluscs  
(b) Arthropods (d) Vertebrates

- (xi) An instrument that measures the blood pressure is known as:
- (a) Haemometer (c) Sphygmomanometer  
(b) Haemocytometer (d) Haemoglobinometer
- (xii) Pacemaker is synonymous with:
- (a) SA Node (c) AV Node  
(b) Bundle of His (d) Purkinje fibers
- (xiii) Find out the correct route of blood circulation:
- (a) Venacavae → Left atrium → Left ventricle → Pulmonary artery → Lung → Pulmonary vein → Right atrium → Right ventricle → Aorta  
(b) Venacavae → Right atrium → Right ventricle → Pulmonary artery → Lung → Pulmonary vein → Left atrium → Left ventricle → Aorta  
(c) Venacavae → Left atrium → Left ventricle → Pulmonary vein → Lung → Pulmonary artery → Right atrium → Right ventricle → Aorta  
(d) Venacavae → Left atrium → Right ventricle → Pulmonary artery → Lung → Pulmonary vein → Left atrium → Right ventricle → Aorta
- (xiv) Find the incorrect match:
- (a) Blood group A – Antigen A on red cell and anti-B antibody in the serum  
(b) Blood group B – Antigen B on red cell and anti-A antibody in the serum  
(c) Blood group AB – Antigen B on red cell and anti-A antibody in the serum  
(d) Blood group O – No antigen A or B on the red cell and both anti-A and anti-B in the serum
- (xv) The fourth heart sound is produced by:
- (a) Closure of the aortic and pulmonary valves  
(b) Closure of the bicuspid and tricuspid valves  
(c) Vibration in the ventricular wall during systole  
(d) Rapid ventricular filling
- (xvi) Which of the following is not a part of the intrinsic blood coagulation pathway:
- (a) Tissue thromboplastin (c) Fibrinogen  
(b) Prothrombin (d)  $Ca^{2+}$
- (xvii) Thalassemia is characterized by:
- (a) Globin chains are abnormal in haemoglobin  
(b) The structure of heme is altered in haemoglobin  
(c) Decreased synthesis of normal globin chains in haemoglobin  
(d) Complete absence of globin chains in haemoglobin

- (xviii) Complete (third degree) heart block is due to:
- (a) Ventricular fibrillation
  - (b) The conduct from the atria to the ventricles is completely interrupted
  - (c) The conduct from the atria to the ventricles is partially blocked or slowed
  - (d) One branch of the bundle of His is inhibited

**2. Answer the following in one word :**

- (i) The blood-filled space and the blood in cockroach.
- (ii) The number of pulsatile chambers in the heart of cockroach.
- (iii) The heart of cyclostomes and fishes through which deoxygenated blood always circulates.
- (iv) The percentage of erythrocytes in the total volume of human blood.
- (v) Swelling and disintegration of erythrocytes in a hypotonic solution.
- (vi) Shrinking of erythrocytes in a hypertonic solution.
- (vii) Iron is transported in conjugation with a protein carrier in the blood.
- (viii) Higher number of erythrocytes than normal in the blood.
- (ix) Abnormally lower haemoglobin percentage in the blood.
- (x) Lack of ankyrin in the cytoskeleton of erythrocytes causes a hereditary disorder.
- (xi) An amino acid substitution in the  $\beta$ -globin chain of the haemoglobin causes a hereditary disorder.
- (xii) Expression of abnormal polypeptides in the haemoglobin by mutant genes gives rise to a pathological condition.
- (xiii) Decreased synthesis of normal  $\alpha$ - and  $\beta$ -globin chains gives rise to a pathological condition.
- (xiv) Trans membrane migration of leucocytes into the tissues from the blood vessels.
- (xv) The site of maturation of lymphocytes into B-lymphocytes takes place in an organ of bird.
- (xvi) An enzyme from the damaged tissue that activates prothrombin into thrombin.
- (xvii) An abnormally higher number of thrombocytes in the blood.
- (xviii) An abnormally lower number of thrombocytes in the blood.
- (xix) The process of formation of erythrocytes in the bone marrow.
- (xx) The cytokine, thrombopoietin stimulates a large multinucleate cell to form a large number of platelets
- (xxi) The inter-atrial connection in the embryonic heart of human.
- (xxii) The footprint of embryonic inter-atrial connection in the inter-atrial septum of the adult.

- (xxiii) A vascular connection between the pulmonary trunk and the aorta in the embryonic heart of human.
- (xxiv) The outer squamous epithelium layer of the heart.
- (xxv) The innermost squamous epithelium layer of the heart.
- (xxvi) The tendinous threads attaching the atrio-ventricular valves with the papillary muscles.
- (xxvii) The blood pressure is measured by an instrument.
- (xxviii) The sound detected by the stethoscope in measuring the blood pressure.
- (xxix) A protein that activates inactive plasminogen into active plasmin.
- (xxx) The clinical condition, in which the conceived Rh<sup>+</sup> fetus by the Rh<sup>-</sup> mother dies.
- (xxxi) The trade name of the anti-Rh antibody preparation injected into the Rh<sup>-</sup> mother.
- (xxxii) The hardening and constriction of large and medium sized arteries due to the deposition of metabolic byproducts on the endothelium.
- (xxxiii) The constriction of the lumen of large and medium sized arteries due to deposition of lipids or their derivatives on the endothelium.
- (xxxiv) The unbearable pain in the heart due to formation of an excess of lactate in the cardiac muscle due to prolonged ischemia (lack of oxygen).
- (xxxv) An irreversible injury followed by death to the myocardial cells due to prolonged ischemia.
- (xxxvi) The drug that prevents atherosclerosis by inhibiting an enzyme in the cholesterol biosynthetic pathway in the liver.
- (xxxvii) The radiograph that detects blockages in the coronary artery.
- (xxxviii) The technique of clearing the blockages in the coronary artery.
- (xxxix) A cylindrical support attached to the artery to prevent its narrowing down subsequently.
- (xl) Abnormal patterns of electrical conduction in the heart causes abnormal beating.
- (xli) A cardiac rate slower than 60 beats/min.
- (xlii) A cardiac rate faster than 100 beats/min.
- (xlili) The coordinate contraction of myocardial cells at a rate of 200-300/min.
- (xliv) The contraction of different groups of myocardial cells at different times.
- (xlv) Ventricular fibrillation leads to complete cessation of blood supply to the brain and hence it's functioning.

**3. Fill in the blanks with appropriate words:**

- (i) Blood circulation in human was discovered by \_\_\_\_\_.
- (ii) There are 13 pulsatile chambers in the heart of cockroach. Each chamber opens by apertures, known as \_\_\_\_\_.
- (iii) Two perforated diaphragms divide the haemocoel of cockroach into three sinuses, namely, \_\_\_\_\_, \_\_\_\_\_ and \_\_\_\_\_.
- (iv) \_\_\_\_\_ muscles, attached to the dorsal diaphragm regulate the contraction and relaxation of the heart in cockroach.
- (v) In double circulation, there are two circuits. One is pulmonary and the other is \_\_\_\_\_.
- (vi) The average longevity of human erythrocytes is \_\_\_\_\_ days.
- (vii) Human erythrocytes, often, pile up on their lateral sides forming a \_\_\_\_\_.
- (viii) The respiratory pigment in human blood is known as \_\_\_\_\_.
- (ix) Haemoglobin is a conjugate protein consisting of a protein part, \_\_\_\_\_, conjugated to a non-protein part, \_\_\_\_\_.
- (x) In fetal haemoglobin (HbF), the beta-globin chains are substituted by \_\_\_\_\_ globin chains.
- (xi) Deficiency of Vitamin B<sub>12</sub> causes \_\_\_\_\_ anemia.
- (xii) Small size of erythrocytes and hence reduced haemoglobin content causes \_\_\_\_\_ anemia.
- (xiii) Excessive destruction of erythrocytes causes \_\_\_\_\_ anemia.
- (xiv) Four oxygen molecules bind to a molecule of haemoglobin one after another forming oxyhaemoglobin. This type of binding is known as cooperative or \_\_\_\_\_ binding.
- (xv) Erythropoiesis is stimulated by a hormone called \_\_\_\_\_, which is secreted by \_\_\_\_\_.
- (xvi) Increase in the number of leucocytes above normal is known as \_\_\_\_\_.
- (xvii) Decrease in the number of leucocytes below normal is known as \_\_\_\_\_.
- (xviii) Neutrophils turn into \_\_\_\_\_ at the site of microbial infection.
- (xix) Infection by helminth larvae causes a proliferation of a class of leucocytes, called \_\_\_\_\_.
- (xx) \_\_\_\_\_ and mast cells release \_\_\_\_\_ at the site of infection, which causes inflammation.
- (xxi) \_\_\_\_\_ infiltrate through the wall of the blood vessels into the tissues and turn into macrophages.

- (xxii) The heart is surrounded by a double-walled membrane, known as \_\_\_\_\_.
- (xxiii) External furrows, marking the internal divisions of the heart are known as \_\_\_\_\_.
- (xxiv) The wall of the heart consists of three layers, such as epicardium, myocardium and \_\_\_\_\_.
- (xxv) The venacavae open into \_\_\_\_\_ of the heart.
- (xxvi) Semilunar valves guard the openings of \_\_\_\_\_ and \_\_\_\_\_ trunks.
- (xxvii) Hemolysis of red cells results in the formation of ruptured plasma membranes, known as \_\_\_\_\_.
- (xxviii) Crenation results in the formation of shrunken erythrocytes, called \_\_\_\_\_.
- (xxix) The left atrio-ventricular aperture is guarded by a \_\_\_\_\_ or \_\_\_\_\_ valve.
- (xxx) Muscular bundles, projecting into the cavities of the ventricles constitute \_\_\_\_\_.
- (xxxi) The heart itself is supplied by \_\_\_\_\_ arteries.
- (xxxii) Persons with \_\_\_\_\_ are treated with digitalis.
- (xxxiii) Numerical expression of normal blood pressure of human is \_\_\_\_\_.
- (xxxiv) \_\_\_\_\_ discovered the ABO blood grouping system.
- (xxxv) The AB blood group was discovered by \_\_\_\_\_ and \_\_\_\_\_.
- (xxxvi) The Rh blood grouping was discovered by \_\_\_\_\_.
- (xxxvii) Persons with \_\_\_\_\_ blood group are known as universal donors.
- (xxxviii) Persons with \_\_\_\_\_ blood group are known as universal recipients.
- (xxxix) The process of forming a clot in the wall of a damaged blood vessel and preventing blood loss is known as \_\_\_\_\_.
- (xl) The endothelial cells secrete \_\_\_\_\_ and \_\_\_\_\_, which act as vasodilators and inhibit platelet aggregation.
- (xli) The intrinsic pathway of blood clotting is initiated by the exposure of the plasma to negatively charged \_\_\_\_\_ at the site of blood vessel damage.
- (xlii) Extrinsic pathway of blood coagulation is initiated by the release of a tissue enzyme, \_\_\_\_\_ at the site of tissue damage.
- (xliii) The enzyme \_\_\_\_\_ lyses fibrin mesh.
- (xliv) Streptokinase, a bacterial enzyme activates \_\_\_\_\_ into \_\_\_\_\_.
- (xlv) Heparin, an anticoagulant activates \_\_\_\_\_.
- (xlvi) Haemophilia A, an X-linked recessive disorder, is caused due to the deficiency of a sub-unit of the blood coagulation factor \_\_\_\_\_. The deficiency in another sub-unit of the same factor causes \_\_\_\_\_ disease.
- (xlvii) Deficiency in the blood coagulation factor IX causes the disease \_\_\_\_\_.
- (xlviii) Defective low density lipoprotein (LDL) receptors on the hepatocyte surface cause an inherited disease, known as \_\_\_\_\_.



**4. Match the words in the Group A with those of Group B to form meaningful pairs of words.**

- | Group A                            | Group B  |
|------------------------------------|--|
| 1. 1. Venacavae and coronary sinus | (a) Left atrio-ventricular aperture  |
| 2. Aortic trunk                    | (b) Right atrium   |
| 3. Pulmonary veins                 | (c) Left ventricle   |
| 4. Pulmonary trunk                 | (d) Right atrio-ventricular aperture   |
| 5. Tricuspid valve                 | (e) Right ventricle  |
| 6. Bicuspid (Mitral) valve         | (f) Left atrium  |
| 2. 1. End diastolic volume         | (a) The vol. of blood that remains in the ventricles following ventricular systole |
| 2. Isovolumetric contraction       | (b) The vol. of blood ejected following ventricular systole.                       |
| 3. Stroke volume                   | (c) The ventricles relax as closed cavities.                                       |
| 4. End systolic volume             | (d) The ventricles contract as closed cavities.                                    |
| 5. Isovolumetric relaxation        | (e) The vol. of blood in the ventricles at the end of ventricular diastole.        |
| 3. 1. Baroreceptor reflex          | (a) Excretion of more water and sodium   |
| 2. Antidiuretic hormone            | (b) Atrial wall  |
| 3. Atrial stretch reflex           | (c) Regulates blood pressure by vasoconstriction.                                  |
| 4. Aldosterone                     | (d) Aortic arch and carotid sinus  |
| 5. Renin-Angiotensin               | (e) Reabsorption of salt and water by the kidneys                                  |
| 6. Atrial Natriuretic Peptide      | (f) Reabsorption of water by the kidneys.  |

**GROUP - B**

**(Short Answer-type Questions)**

1. Answer the following in one or a few sentences:
- (i) Explain about the transport function of blood.
  - (ii) What is open circulation? Give an example.
  - (iii) Why is the heart of cyclostomes and fishes called venous heart?
  - (iv) What is systemic circulation?
  - (v) What is hematocrit?

- (vi) Why is the colour of the plasma straw yellow ?
- (vii) What is a rouleaux? Where it is found ?
- (viii) What do you mean by haemolysis ?
- (ix) What is an echinocyte ?
- (x) What is haemoglobin A ?
- (xi) What is fetal haemoglobin ?
- (xii) Explain about allosteric binding of oxygen to haemoglobin.
- (xiii) What is sickle cell anemia ? How does it differ from haemolytic anemia ?
- (xiv) Explain about leucopenia.
- (xv) What is thalasemia ?
- (xvi) What is diapedesis ?
- (xvii) A basophil is functionally related to an areolar connective tissue cell. Name the cell and explain the function.
- (xviii) Enumerate the types of granulocytes and their individual functions.
- (xix) Mention the two major functions of lymphocytes.
- (xx) What is hematopoiesis? Where does it occur ?
- (xxi) Enumerate why the human heart is myogenic.
- (xxii) What is fossa ovalis ?
- (xxiii) Why are atrio-ventricular valves called cuspid valves ?
- (xiv) What do you mean by action potential ?
- (xv) For a moment (0.4 sec), the entire heart is in diastole-explain.
- (xvi) What do lubb and dupp signify ?
- (xvii) The standard notation of blood pressure (120 / 80 mm Hg) refer to systolic and diastolic pressures of the systemic circulation-Explain.
- (xviii) How do antidiuretic hormone (ADH) regulate blood pressure ?
- (xix) What is aldosterone ? How it is related to the maintenance of blood pressure ?
- (xxx) What is ECG ?
- (xxxii) What happens if there is a mismatched blood transfusion ?
- (xxxiii) What is hemolytic disease of the newborn ?
- (xxxiv) What is platelet plug ?
- (xxxv) What is platelet release reaction ?
- (xxxvi) What is the function of streptokinase ?
- (xxxvii) What is EDTA? How does it help in blood preservation ?
- (xxxviii) How does heparin act as an anticoagulant ?
- (xxxix) What is arteriosclerosis ?
- (xl) What is the role of cholesterol in producing atherosclerosis ?

- (xl) What is angioplasty ?
- (xli) How does tPA help in dissolving a thrombus ?
- (xlii) What is bradycardia ?
- (xliii) What is lymph? How does it circulate ?

**2 Write brief notes on the following :**

- |                                 |                              |
|---------------------------------|------------------------------|
| (a) Functions of blood          | (m) Heart sounds             |
| (b) Agranulocytes               | (n) Cardiac output           |
| (c) Double circulation          | (o) Electrocardiogram        |
| (d) Haemoglobin                 | (p) Agglutination reaction   |
| (e) Erythrocyte                 | (q) Anticoagulants           |
| (f) Anemia                      | (r) Hemophilia               |
| (g) Thalasemia                  | (s) Hypertension             |
| (h) Erythropoiesis              | (t) Ischemic heart disease   |
| (i) Bone marrow transplantation | (u) Atherosclerosis          |
| (j) Neurogenic heart            | (v) Congestive heart failure |
| (k) Pacemaker                   | (w) Lymphatic system         |
| (l) Artificial pacemaker        | (x) Myocardial infarction    |
| (y) Blood coagulation           | (z) ABO blood groups         |

**3. Differentiate between two words in the following pairs :**

- (i) Plasma and Serum
- (ii) Blood and Lymph
- (iii) Open circulation and Closed circulation
- (iv) Single circulation and Double circulation
- (v) Haemolysis and Crenation
- (vi) Adult haemoglobin and Fetal haemoglobin
- (vii) Granulocytes and Agranulocytes
- (viii) Sickle cell anemia and Haemolytic anemia
- (ix) Pulmonary circulation and Systemic circulation
- (x) Bicuspid and Tricuspid valves
- (xi) Systole and Diastole
- (xii) SA node and AV node
- (xiii) Universal donor and Universal recipient
- (xiv) Hemophilia A and Hemophilia B
- (xv) Haemoglobinopathy and Thalasemia
- (xvi) Arteriosclerosis and Atherosclerosis
- (xvii) Flutter and Fibrillation

4. Label different parts as numbered in the following figures :

(i)

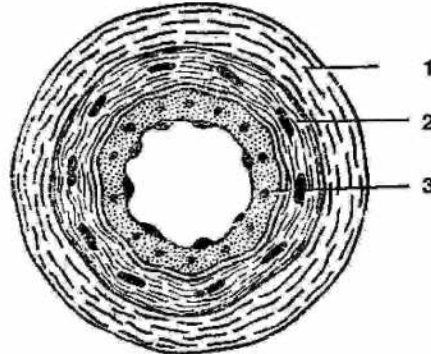

(ii)

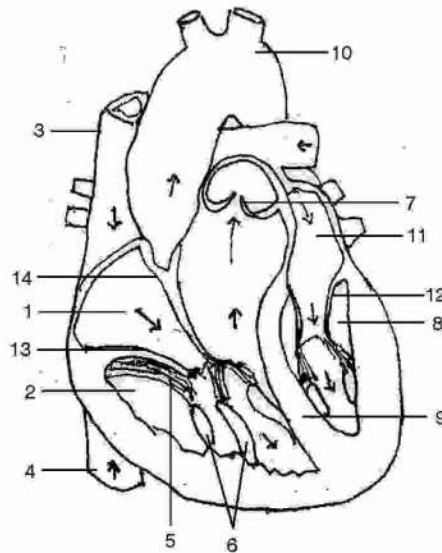

**GROUP - C**

**(Long Answer-type Questions)**

1. Describe the constitution and functions of human blood.
2. Describe the structure of human heart and discuss about the mechanism of circulation.
3. Give an account of the conducting tissue of the human heart and describe about the origin and conduction of heart beat.
4. Define cardiac cycle. Describe the events in the cardiac cycle and its regulation.
5. Draw a neat labeled diagram of the longitudinal (vertical) section of human heart (Description not required).

Draw neat labeled diagrams of the transverse sections of a vein and an artery (Description not required).



Excretion is the process by which waste products of metabolism are removed from the body. A number of wastes and injurious substances are formed during metabolism. These include carbon dioxide, excess of water and salts, a number of nitrogenous waste products such as ammonia, urea and uric acid and bile pigment, the removal of which is essential for the normal functioning of the organs and organ systems. Excretion also helps in osmo-regulation which is the maintenance of constancy, in particular of sodium chloride that helps in the distribution of body water and its retention and regulation. It also helps to maintain the acid base balance of the body.

All those organs in which the excretory products are processed, prior to their elimination from the body, are involved in excretion and therefore can be called excretory organs. These include the skin, lungs, liver, alimentary canal and the kidneys. Skin by forming sweat serves to eliminate water, urea and salts that are actively secreted from the capillaries in the blood vessels of the skin, from which the water also evaporates. This helps to lose heat from the body and regulates body temperature. Lungs help to eliminate carbon dioxide that is transported by the blood from the tissues in exchange with Oxygen of the alveoli. Liver forms urea and uric acid from the ammonia by urea and uric acid synthesis and eliminates them from the body by filtering in the kidneys. Liver also forms bile and eliminates through it the bile pigments that originate from the breakdown of old erythrocytes in the spleen. Alimentary canal eliminates undigested matter in the food and the bile pigments of the bile formed in the liver. Of all these organs, the kidneys are the most important which have been developed by vertebrates especially for the elimination of nitrogenous waste products from the body, which are highly toxic.

### 18.1. TYPES OF NITROGENOUS EXCRETORY PRODUCT :

Nitrogenous waste products are formed from the breakdown of proteins, nucleic acids and excess amino acids. The primary product of this breakdown is ammonia. It is produced by deamination of amino acids, a process by which the amino group of the amino acid is removed. Ammonia may be excreted as such, as immediately as possible, or is converted into less toxic urea or the highly insoluble uric acid and then excreted. The exact nature of the nitrogenous excretory product depends on the availability of water in the habitat in which the animal lives, and the extent to which it can control water loss.

### 18.1.1. Ammonotelism :

The main source of ammonia in the body tissues is the deamination of excess amino acids. Excess amino acids are not stored to any great extent in the body and are therefore catabolised. Excess amino acids are degraded to their keto acid and ammonia by oxidative deamination. Keto groups are used in catabolism for production of ATP and ammonia excreted out.

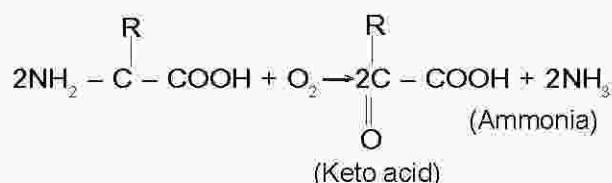

Since ammonia is highly toxic, it is removed in the form of dilute solution or simply diffuses out from the body directly. This process of removal of nitrogenous waste material in the form of ammonia from the body is called **ammonotelism** and the animals are called **ammonotelic animals**. Since the process requires large volume of water for removal of ammonia in the form of dilute solution, it is found in aquatic animals like **Protozoa, Sponges, Coelenterates, Prawn, Molluscs, Tadpole of frog, Bony fish, Tailed amphibians and Crocodile etc.**

### 18.1.2. Ureotelism :

In certain animals, ammonia is converted to urea by combining with  $\text{CO}_2$  in the liver by a cyclic process called **Ornithine cycle**. Urea is less toxic for the body and is removed in the form of solution. Since urea is less toxic for the body, it can be stored in the body for longer period without any adverse impact. The process by which animals produce urea is called **ureotelism** and the animals are called **ureotelic animals**. Examples - **Mammals, Adult frog and Toads, Earthworm when present on land & Cartilaginous fish etc.**

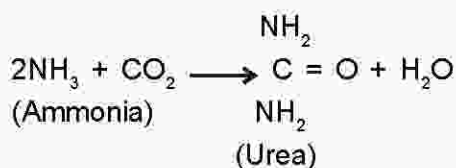

### 18.1.3. Uricotelism :

In some animals ammonia is converted to uric acid for removal. Uric acid is least toxic and requires very little water for removal as it is insoluble in water.

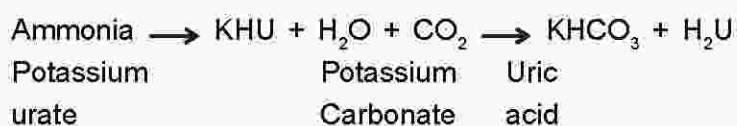

The process by which animals produce uric acid as waste material is called **Uricotelism** and the animals are called **Uricotelic animals**. It is found in terrestrial animals in which conservation of body water is essential for survival.

Example - **Insects, Snakes, Lizards & Birds** etc.

Human beings excrete small quantity of uric acid which is produced from the breakdown of nucleic acid.

**Table - 18.1**

**Relationship between habitats and excretory products of animals.**

Animal	Excretory product	Habitat
Protozoa	Ammonia	Aquatic
Terrestrial insect	Uric acid	Terrestrial
Freshwater bony fish	Ammonia	Aquatic
Marine bony fish	Urea, TMA	Aquatic
Birds	Uric acid	Terrestrial

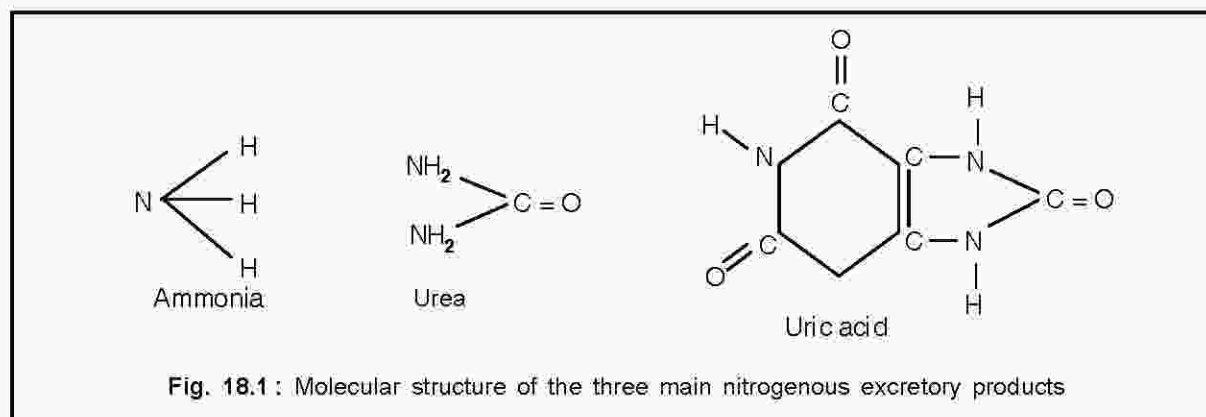

#### 18.1.4. Other nitrogenous wastes :

(i) **Amino acids** : Certain molluscs and echinoderms excrete amino acid as the end products of protein digestion and are called **aminotelic animals**, ex- *Unio*, *Limnea*, *Asterias*, and *Pentaceros*.

(ii) **Tri-methyl amine oxide (TMAO)** : In marine teleost fish, certain molluscs and crustaceans, the nitrogenous waste is TMAO which is formed from ammonia. The product is soluble in water and less toxic than urea. TMAO is utilised in the body along with urea to maintain osmotic equilibrium with sea water which contains a high concentration of salts and tends to dehydrate the body. It is the excretory product in *Octopus*, *Squid*, *Copepods*, *Crabs* and *Barnacle*.

(iii) **Guanine** : Spiders excrete ammonia in the form of guanine. It is insoluble in water like uric acid.

(iv) **Allantoin** : Certain organic bases like purine and pyrimidine are excreted in mammals in the form of allantoin.

(v) **Creatine, creatinine, - Hippuric acid and Ornithuric acid** - are other nitrogenous wastes excreted in animals.

## 18.2. EXCRETORY SYSTEM IN HUMAN (Fig. 18.2) :

In human beings and other terrestrial vertebrates a number of organs in the body function as excretory organs. Of all these, **kidneys** function as the major excretory and osmo-regulatory organ. Human kidneys are **metanephric** which have the ability to produce urine that is almost five times more concentrated than that of the blood plasma.

A number of metabolic wastes are eliminated by the kidneys from the human body. These include **urea** from **proteins**, **uric acid** from **nucleic acids**, **creatinine** from **muscle**, the end products of haemoglobin breakdown which give urine much of its colour, excess of water, salts and acids and foreign chemicals.

### Functions of the kidneys.

1. Regulation of water and inorganic ion balance
2. Removal of metabolic wastes from the body and their excretion in the urine.
3. Acid - base balance of the body and thereby the regulation of the hydrogen ions of body fluids.
4. As a major homeostatic organ, regulation of the chemical composition of the body fluids by the removal of substances which are in excess of immediate requirements including foreign chemicals.
5. Secretion of hormones like erythropoietin which controls erythrocyte production in the body, renin which controls formation of angiotensin that influences blood pressure and sodium balance.

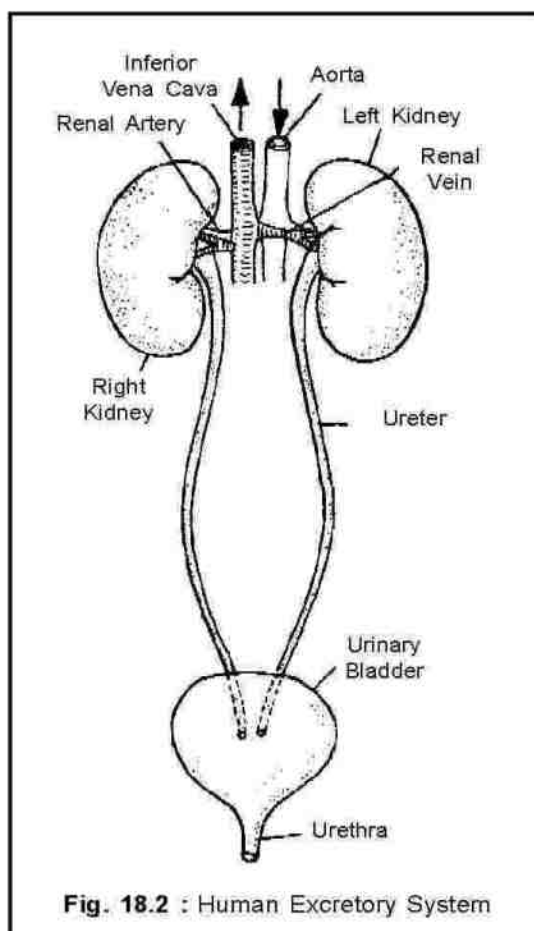

Fig. 18.2 : Human Excretory System



**18.2.1. Organs of excretion :**

It consists of the following parts :

1. Pair of Kidneys
2. Pair of Ureters
3. Urinary bladder
4. Urethra

**18.2.1.1. Kidney :** A pair of kidneys are located in the anterior part of abdominal cavity, one on each side of the vertebral column. Each kidney is bean shaped of about 10 cm long, 5 cm wide and 2.5 cm thick. They are dark red in colour and each weigh about 150

gms. There is a concavity on the inner side of the kidney called **hilum** or **hilus**. Blood vessels and ureters are attached to kidneys through the hilum. Each kidney receives blood through a single **renal artery** and the filtered blood leaves the kidney through **renal vein**. The kidneys are **retroperitoneal** in position. Left kidney is located slightly higher in position and near to midline than the right kidney. The floating ribs that is, 11th and 12th pairs provide protection to the kidneys. Human kidneys are **metanephric** in nature.

**18.2.1.2. Ureters :** From each kidney comes out a narrow whitish tube through the hilum called **ureter**. It is about 25-30 cm long. Both the ureters run downwards and open to **urinary bladder**. Ureters carry urine from kidneys to urinary bladder. Urine passes through ureters due to peristaltic movements in it.

**18.2.1.3. Urinary bladder :** It is located in the pelvic cavity and stores the urine. It is muscular and extensible in nature. Internally it is lined by **transitional epithelium** and covered by smooth muscles called **detrusor muscles**. Internally the urinary bladder has a triangular area called **trigone**. It prevents back flow of urine from bladder to ureters.

**18.2.1.4. Urethra :** It is a tube which removes the urine from the bladder to exterior. The connection between bladder & urethra is guarded by a pair of sphincters. In the males, urethra is a long tube and opens to outside at the tip of the male genital organ, **Penis**. In the females, it is relatively shorter in length. Urethra in males carries both urine and semen but in females it carries only urine.

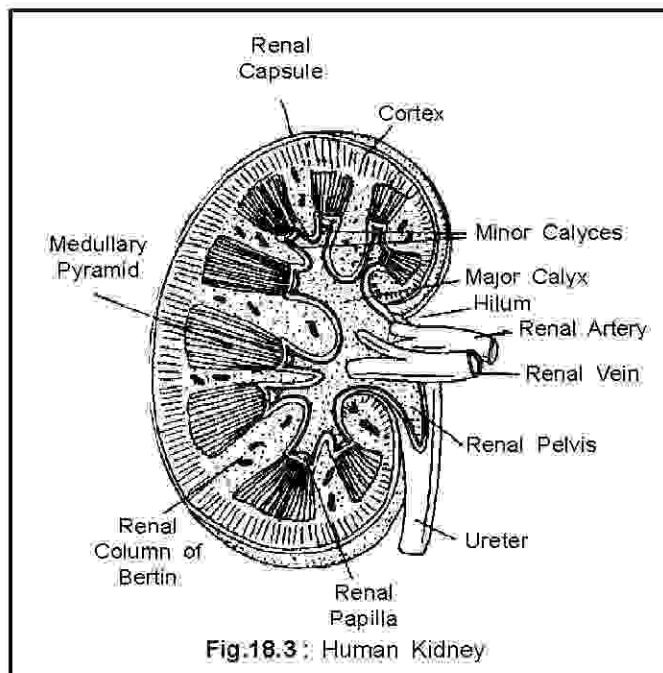

### 18.3. STRUCTURE OF KIDNEY :

Kidney is covered by a **renal capsule** consisting of fibrous connective tissue. Renal capsule provides protection. Inner to the capsule is a dark region called **cortex**. Below the cortex is present a lighter region called **medulla**. Medulla is divided into 10-5 conical areas called **medullary pyramids** or **renal pyramids** having their broad bases towards the cortex and their narrow tips towards the interior. The distal convoluted tubules of a number of adjacent nephrons open into a common collecting tubule. These tubules traverse through the medulla in the pyramids and opens to **Duct of Bellini**. Ducts of Bellini open to minor calyces which finally open to pelvis.

The functional units of kidney are **nephrons** or **uriniferous tubules**. There are about 10-13 lakhs of nephrons in each kidney. Length of a nephron varies from 45-65 mm.

#### 18.3.1. Structure of a nephron :

Each nephron is a coiled tubule with following regions:-

**18.3.1.1. Bowman's capsule :** Each nephron begins with a Bowman's capsule which is a double walled sac like structure. Its outer wall consists of flattened squamous cells and the inner wall consists of **podocytes**. These cells bear distinct finger like processes which entwine around capillaries of glomerulus.

**18.3.1.2. Glomerulus :** The cavity of Bowman's capsule contains a mass of blood capillaries called **glomerulus**. Blood enters into glomerulus from **afferent arteriole** and comes out through **efferent arteriole**. Glomerulus is the place where the blood is filtered. Bowman's capsule plus glomerulus is called **Malpighian body** and is located in the cortex of the kidney.

**18.3.1.3. Neck :** Bowman's capsule is followed by neck which has ciliated epithelium.

**18.3.1.4. Proximal convoluted tubule (PCT) :** It is present behind the neck and is convoluted and forms few coils. It is present in the cortex. The wall of proximal convoluted tubule consists of a single columnar epithelium with **brush border** of **microvilli**.

**18.3.1.5. Loop of Henle :** It is a narrow U-shaped tubule having a **descending limb** which extends into medulla and an **ascending limb** which extends back from medulla into cortex.

**18.3.1.6. Distal convoluted tubule (DCT) :** It is the most distal part of nephron and situated in the cortex. It is also convoluted and forms few coils. The narrow terminal part of each pyramid is known as **renal papilla**. Between the pyramids, the cortex extends into the medulla as **renal columns of Bertini**. The renal pyramids open to 10-15 small tubes called **minor calyces** (singular-minor calyx). Minor calyces join to form 2-3 major calyces. The major calyces join to form a large funnel shaped structure called **renal pelvis**, which in turn leaves the kidney through **hilus** and forms the **ureter**.

**Malpighian body, proximal and distal convoluted tubules** of nephrons constitute the **renal cortex**, whereas **loop of Henle, collecting tubules & Ducts of Bellini** constitute **renal medulla**.

### 18.3.2. Types of nephron :

There are two types of nephrons : **Cortical nephrons** and **juxtamedullary nephrons**, which differ in their position and size. **Cortical nephrons** are small sized, found mostly in the cortex, with short loops of Henle, which just extend into the medulla. **Juxtamedullary nephrons** are large sized with long loops of Henle extending deep into the medulla. Such large sized nephrons are specialised for water reabsorption. Under normal conditions of water availability the cortical nephrons deal with the control of blood volume, whereas, when water is in short supply increased water retention occurs through the juxtamedullary nephrons.

### 18.3.3. Blood supply to the nephron :

Blood to each kidney is supplied by a **renal artery** and is drained by the **renal vein**. Both the blood vessels and the ureter pass through a concavity of the kidney, on the ventral side, called the hilus. Upon entering into the kidney, the renal artery divides into several interlobular arteries, which finally divide into many **afferent arterioles**.

Each afferent arteriole enters into a glomerulus, and forms a tuft of capillaries. The capillaries reunite to form the **efferent arteriole** which drains the glomerular network. While the blood passes through the glomerular capillaries from the afferent to the efferent the blood is filtered (Afferent means to and efferent means from)

The efferent arteriole again forms a network of peritubular capillaries around the proximal convoluted tubule and the distal convoluted tubule. Long hairpin like loops of blood

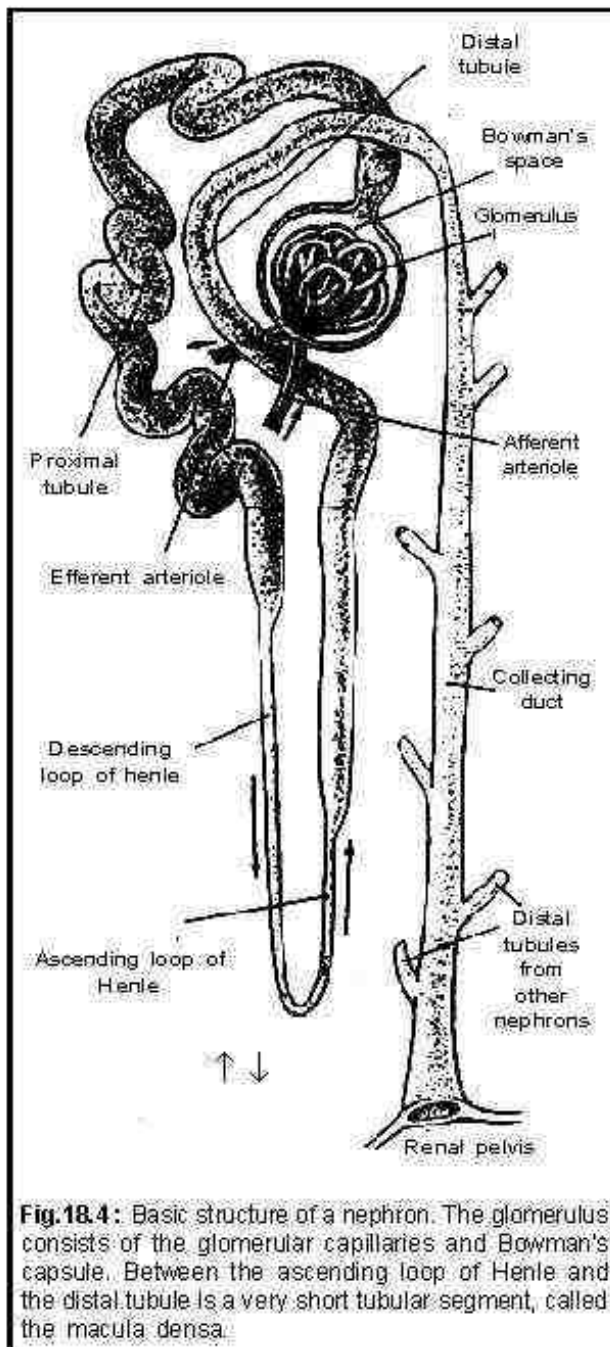
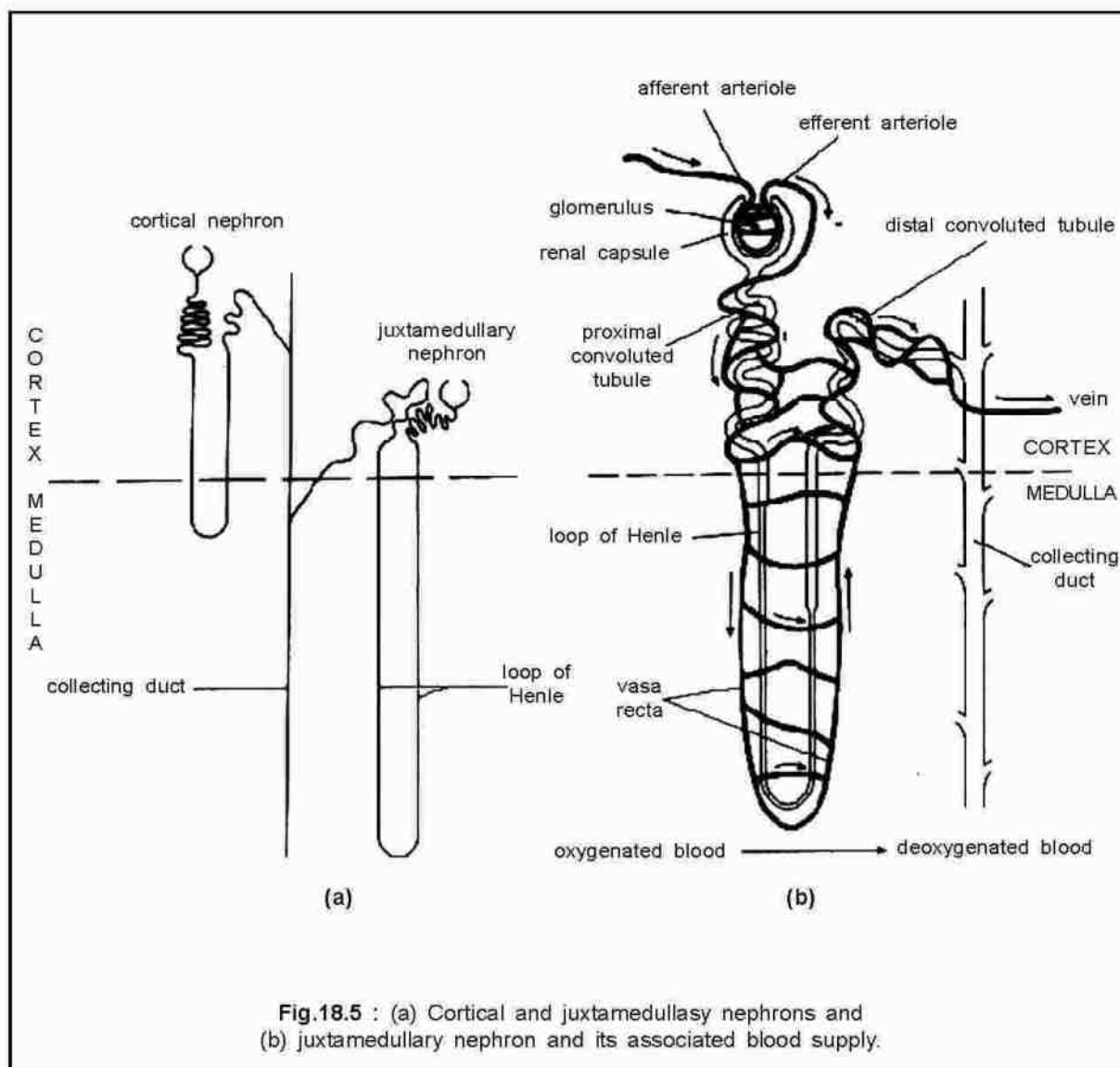

**Fig.18.4 :** Basic structure of a nephron. The glomerulus consists of the glomerular capillaries and Bowman's capsule. Between the ascending loop of Henle and the distal tubule is a very short tubular segment, called the macula densa.

vessels are given off from these capillary networks parallel to the 'Henle's loops. These are called *vasa recta*.

#### 18.3.4. Juxtaglomerular apparatus and the secretion of angiotensin :

The ascending limb of Henle's loop passes in between the afferent and efferent arterioles. This short segment of the Henle's loop is known as the macula densa. The macula densa together with granular cells present in the wall of the afferent arteriole form the juxtaglomerular apparatus which is the source of the hormone renin. Renin converts Angiotensinogen to Angiotensin I which is changed to Angiotensin II by an enzyme from the liver. Angiotensin II is a strong stimulator of aldosterone secretion. Aldosterone is the corticosteroid hormone from the adrenal cortex which controls water and  $\text{Na}^+$  loss from the body in the urine.



**Fig.18.5 :** (a) Cortical and juxtamedullary nephrons and (b) juxtamedullary nephron and its associated blood supply.

**18.4. FORMATION OF URINE :**

Formation of urine is a complex process consisting of following steps :

- (a) **Synthesis of urea**
- (b) **Ultrafiltration**
- (c) **Selective reabsorption**
- (d) **Tubular secretion**

Of these four steps, the first step has been described below under **ornithine cycle**.

**18.4.1. Ultra-filtration :**

Ultra-filtration is filtration under pressure which occurs in the glomerulus. This pressure comes from the blood pressure and is called the Net filtration pressure (NFP). Net filtration pressure is the blood pressure (mean systolic pressure in the glomeruli) minus the osmotic pressure of the blood and the Bowman's capsular pressure.

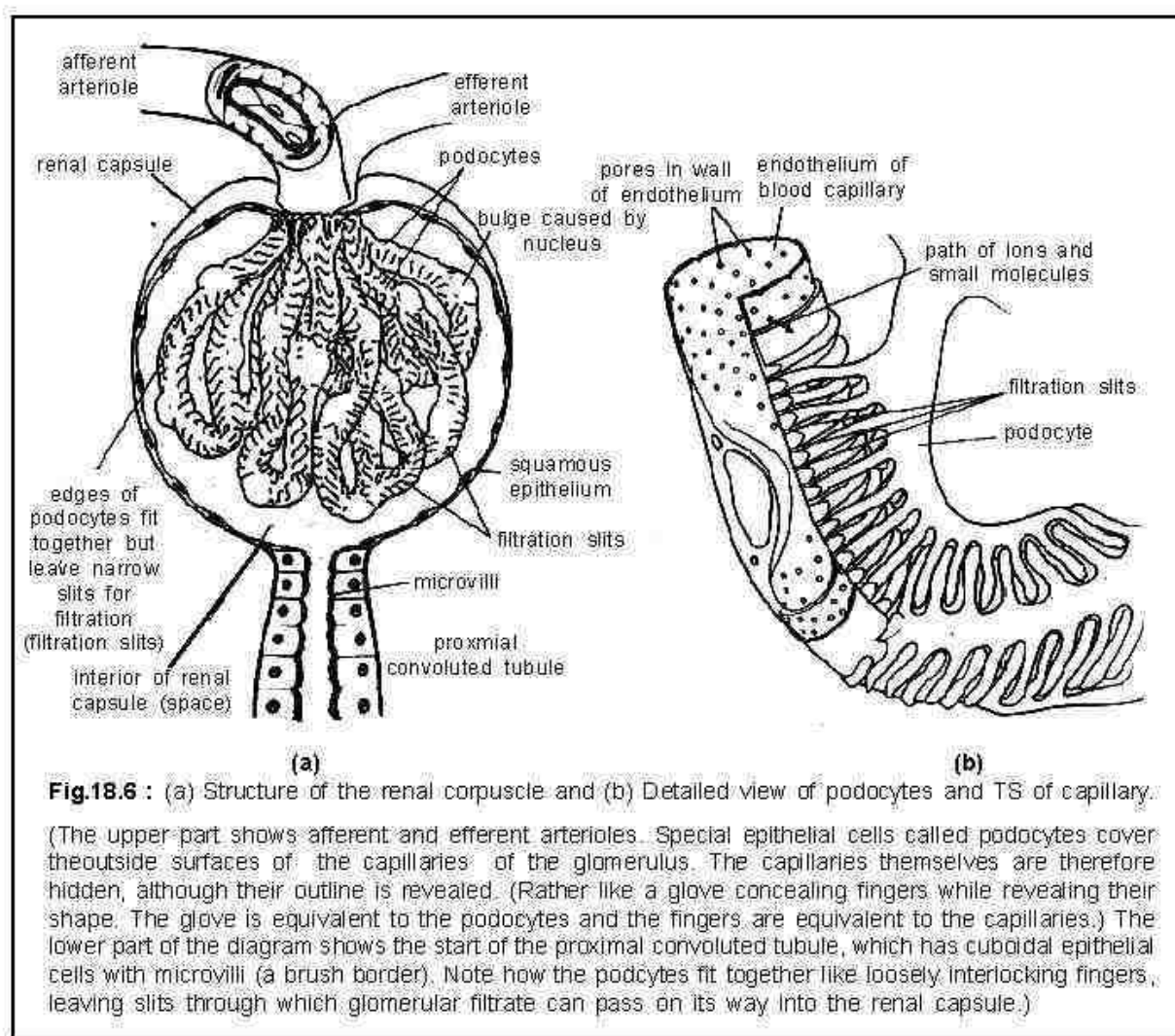

**Fig.18.6 :** (a) Structure of the renal corpuscle and (b) Detailed view of podocytes and TS of capillary.

(The upper part shows afferent and efferent arterioles. Special epithelial cells called podocytes cover the outside surfaces of the capillaries of the glomerulus. The capillaries themselves are therefore hidden, although their outline is revealed. (Rather like a glove concealing fingers while revealing their shape. The glove is equivalent to the podocytes and the fingers are equivalent to the capillaries.) The lower part of the diagram shows the start of the proximal convoluted tubule, which has cuboidal epithelial cells with microvilli (a brush border). Note how the podocytes fit together like loosely interlocking fingers, leaving slits through which glomerular filtrate can pass on its way into the renal capsule.)

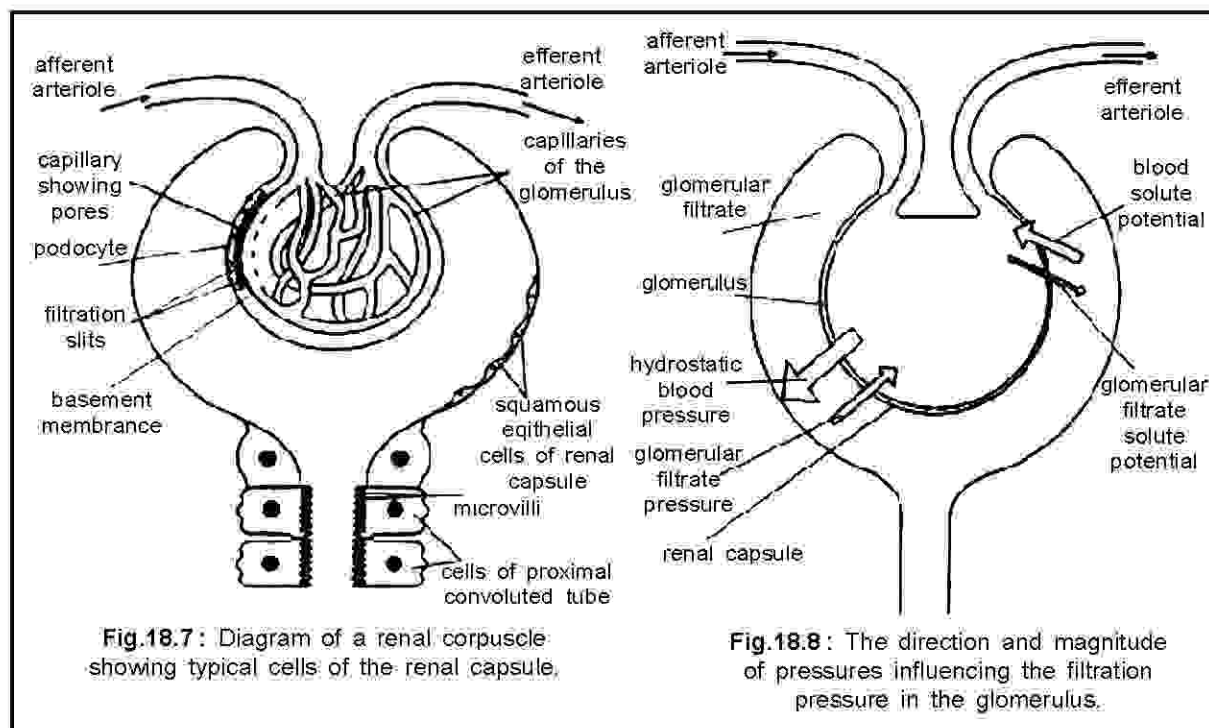

Fig.18.7: Diagram of a renal corpuscle showing typical cells of the renal capsule.

Fig.18.8: The direction and magnitude of pressures influencing the filtration pressure in the glomerulus.

By the time the blood reaches the glomeruli the mean systolic pressure decreases to its 70 % in the arm i.e. 75 mm Hg opposed by the osmotic pressure of the blood i.e. 30 mm Hg plus the Bowman's capsular pressure i.e. 20 mm Hg.

Net Filtration pressure = Mean systolic pressure in the glomeruli – (Osmotic pressure of the blood + Bowman's capsular pressure)

$$= 75 \text{ mm Hg} - (30 \text{ mm Hg} + 20 \text{ mm Hg})$$

$= 75 \text{ mm Hg} - 50 \text{ mm Hg}$  Net filtration pressure = 25 mm Hg The NFP of 25 mm Hg causes filtration in the glomeruli.

#### Glomerular filtration rate

The quantity of glomerular filtrate formed each minute by both the kidneys is called **glomerular filtration rate**. It is about 125 ml. So about 180 litres of filtrate is formed per day. But in a normal adult about 1.5 litres of urine is excreted per day. So the rest filtrate is reabsorbed in the tubules. GFR is about  $1/5^{\text{th}}$  of renal plasma flow.

#### Nature of the glomerular capillaries and filtration :

The glomerulus is a knot of capillaries, the diameter of the capillaries is much less than that of the afferent arteriole that carries blood into it, so that when the blood enters the narrow capillaries, pressure rises. Water and small solute molecules are squeezed out of the capillaries through the simple squamous epithelium of the Bowman's capsule into its interior. Long molecules like the protein as well as the RBC and platelets are left behind in the blood. The structure of the glomerulus and the Bowman's capsule is specially adapted for filtration. Filtration takes place through three layers.

**1. Endothelium of the glomerular capillaries**

**2. Basement membrane of the capillaries.**

**3. Epithelium of the Bowman's capsule :** This layer is made up of cells which are highly specialised / modified for filtration; called **podocytes**. (podos meaning foot). Each cell has many foot like extensions which project from its surface. with a diameter of 25 mm. The filtrate can pass through these pores into the cavity of the Bowman's capsule.

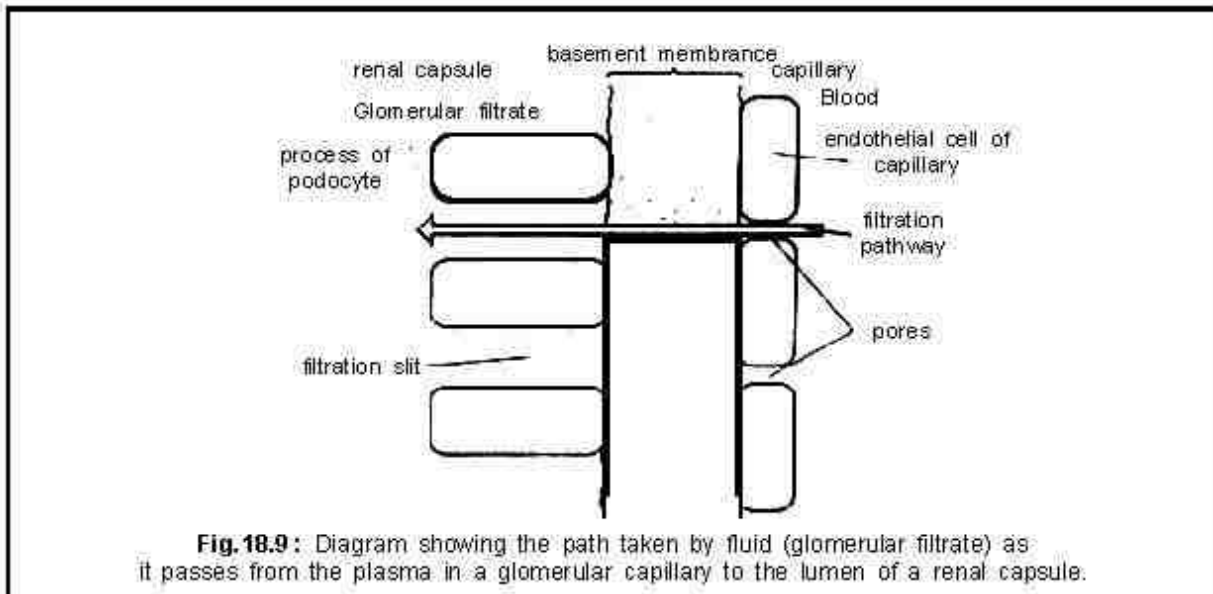

**Fig.18.9 :** Diagram showing the path taken by fluid (glomerular filtrate) as it passes from the plasma in a glomerular capillary to the lumen of a renal capsule.

<b>Forces</b>	<b>mm Hg</b>
<b>Favouring filtration</b>	
Glomerular capillary blood pressure	75.0
<b>Opposing filtration</b>	
Fluid pressure in Bowman's capsule	20.0
Osmotic force (due to proteins) in plasma	30.0
<b>Net filtration pressure</b>	<b>25.0</b>

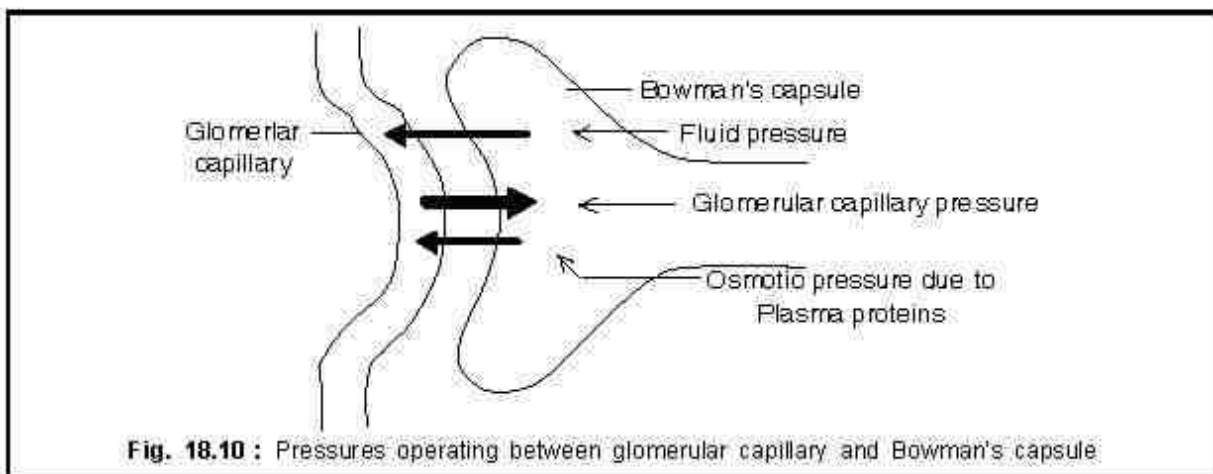

**Fig. 18.10 :** Pressures operating between glomerular capillary and Bowman's capsule

#### 18.4.2. Selective reabsorption :

Ultrafiltration produces above 125 ml of filtrate per minute, equivalent to 180 liters per day. Since only 1.8 liters of urine is produced each day, about 99% of it is reabsorbed. During ultrafiltration many substances which are useful and vital like sodium, water, glucose, amino acid are reabsorbed while substances like urea, foreign chemicals are not reabsorbed to any great extent. The function of the tubule is to selectively reabsorb substances that are useful and to add certain substances by active secretion to the urine. Formation of urine therefore involves three key processes namely **ultra-filtration, selective reabsorption and secretion**. Secretion of Hydrogen ions in exchange with bicarbonate ions or through buffers helps to maintain acid-base balance. The filtrate in the Bowman's capsule is isotonic to blood plasma.

**Table - 18.2**

**Average values for several components that undergo filtration and reabsorption.**

Substance	Amount filtered per day/filtering load	Amount excreted per day	Percent reabsorbed
Water L.	180	1.8	99
Sodium g.	630	3.2	99.5
Glucose g.	180	0	100
Urea g.	54	30	44

(a) **Proximal convoluted tubule** : About 80% of the filtrate is reabsorbed in this region. The brush border of the cells of proximal convoluted tubule helps in the process of reabsorption. This is the place of maximum reabsorption of water and is called obligatory reabsorption. Solutes like glucose, amino acids, vitamins and different salts like chlorides & phosphates of sodium & potassium are reabsorbed by diffusion & active transport. As both water & solutes are reabsorbed, the filtrate remains isotonic to plasma.

(b) **The Loop of Henle** : The function of the loop of Henle is to conserve water. The longer the loop of Henle, the more concentrated the urine that can be produced. This is a useful adaptation to life on land. Birds and mammals are the only vertebrates which can produce a urine which is more concentrated than the blood and they are the only vertebrates with loops of Henle. The drier the natural habitat of an animal, the longer is its loop of Henle. For example, the beaver, a semi-aquatic mammal, has a short loop of Henle and produces a large volume of dilute urine, whereas, the desert-dwelling kangaroo rat and the jerboa (hopping mouse) have long loops of Henle and produce small volumes of highly concentrated urine. Their urine is 6 to 7 times more concentrated than the human urine and they do not need to drink water. They get enough metabolic water produced during respiration.



The loop of Henle has three distinct regions each with its function-

- (i) **Descending limb**, which has thin wall
- (ii) **Thin ascending limb**, which is the lower half of the ascending limb and has thin wall like the descending limb
- (iii) **Thick ascending limb** -this is the upper half of the ascending limb and has thick wall.

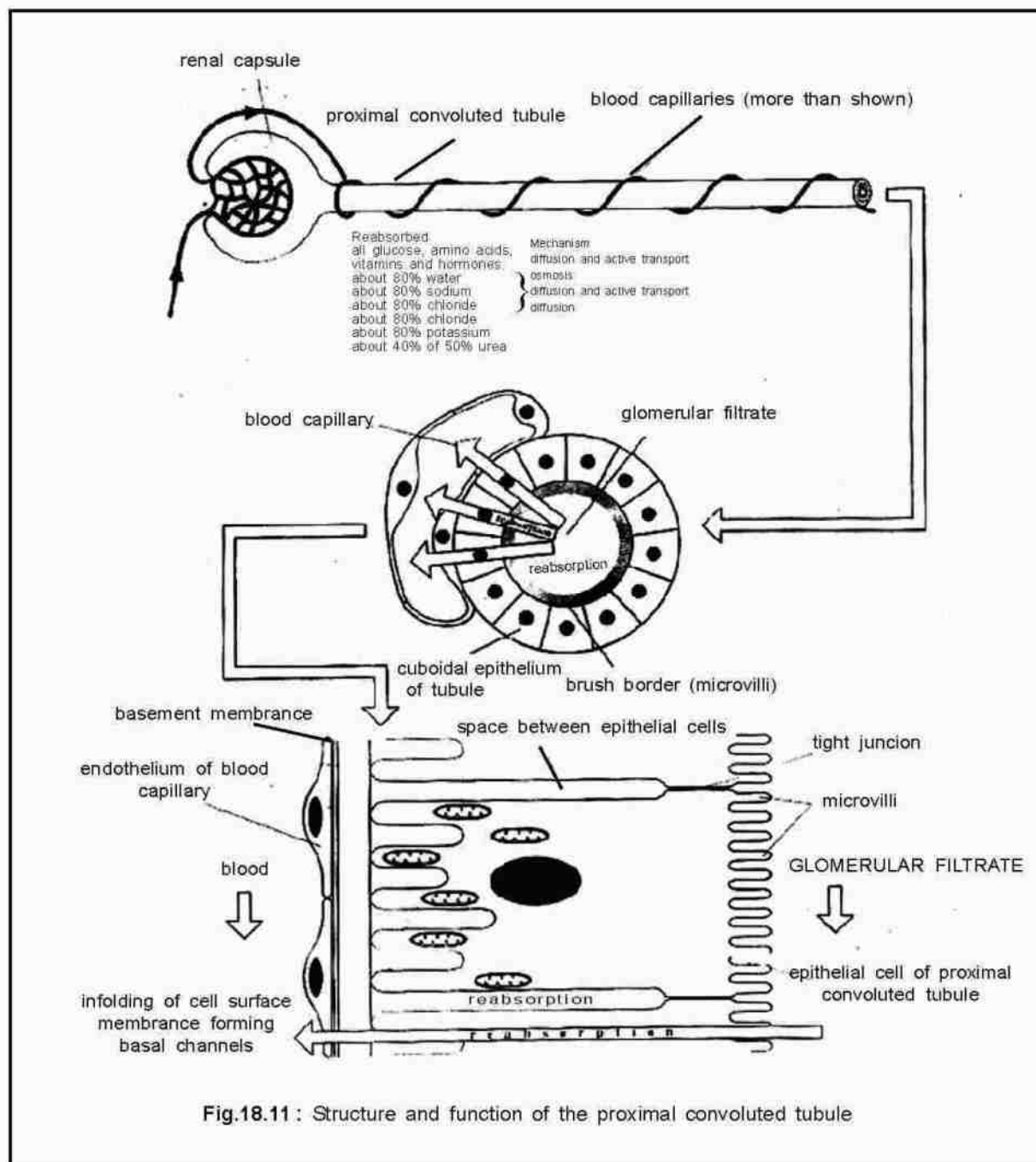

Fig.18.11 : Structure and function of the proximal convoluted tubule

The **descending limb** is permeable to water but not to solutes. As a result the filtrate becomes more concentrated as it moves down along the descending limb of Henle (DLH). So the filtrate becomes **hyperosmotic** to blood plasma. For this reason, **DLH** is called **concentrating segment**.

The ascending loop of Henle (ALH) is permeable to minerals like sodium & potassium salts but impermeable to water. As a result the filtrate becomes gradually dilute and **iso-osmotic** to plasma. So **ALH** is called the diluting segment.

(c) **Distal convoluted tubule and collecting duct** : In these last parts of the nephron, depending on the body's need for water, absorption of water takes place under the influence of the anti-diuretic hormone (ADH) of the posterior pituitary.

If the body needs to retain more water, as such a need might arise in case we go without water for a long period, more ADH shall be secreted from the posterior pituitary, under the influence of which these regions shall become permeable to water and allow more water reabsorption to take place. This kind of reabsorption of water under ADH influence is known as **facultative reabsorption** of water. Movement of definite amounts of water by osmosis along the osmotic gradient is important in osmo-regulation.

In the deficiency of ADH, more water cannot be reabsorbed in the distal convolution and leads to production of large volume of dilute urine. Loss of water of this kind is called diuresis. Osmoreceptors located in the hypothalamus sense the blood and send appropriate stimuli to the posterior pituitary to control ADH release.

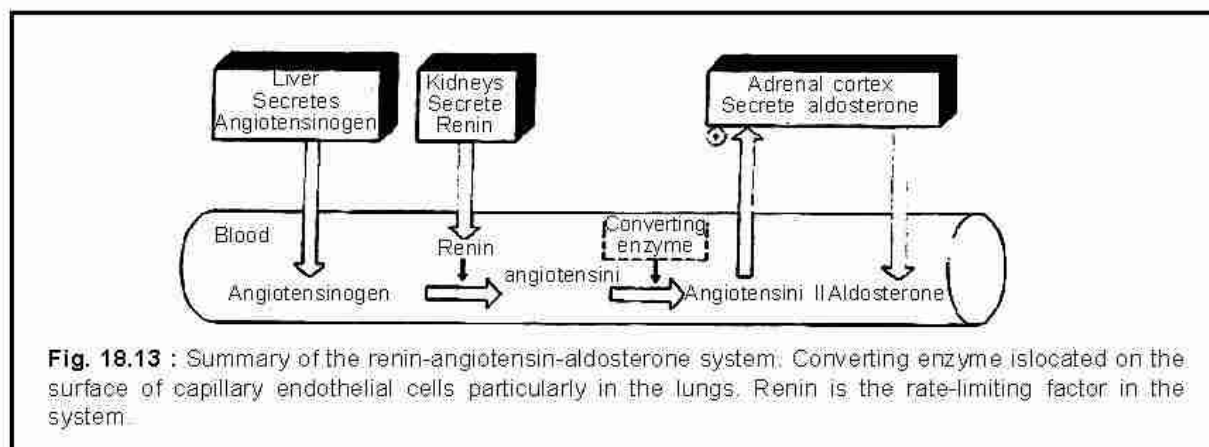
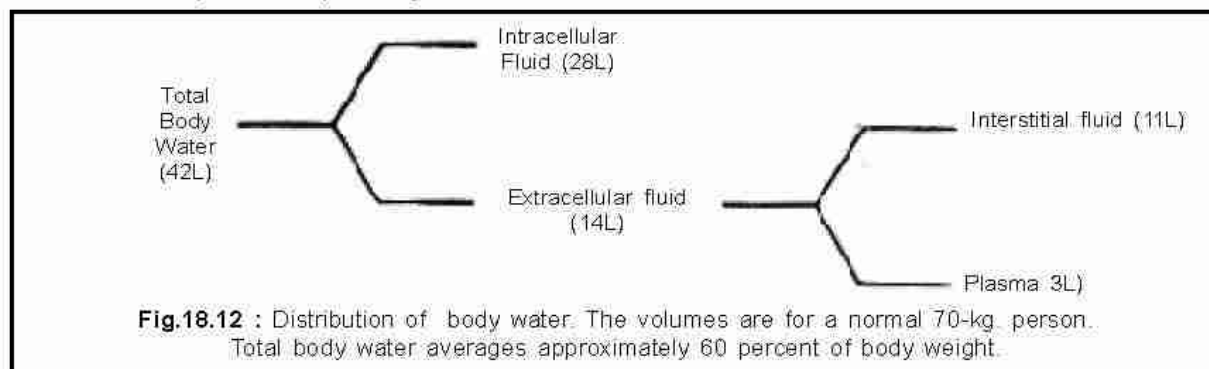

**18.4.3. Tubular secretion :**

Cells of uriniferous tubules not only reabsorb substances but also remove excretory substances from the blood into the filtrate by tubular secretion. This is a process just opposite to reabsorption. Proximal convoluted tubule secretes uric acid, creatinine, hippuric acid and penicillin drug etc. Hydrogen ions and ammonia are also secreted by the PCT. Urea is secreted by the thin segment of the ascending limb of loop of Henle. The DCT secretes potassium, hydrogen ions, ammonia and  $\text{HCO}_3^-$  ions etc. Maximum hydrogen ion secretion occurs in the region of PCT. Secretion of hydrogen ions & ammonia helps to maintain the pH of the blood around 7.3

**Table - 18.3****Chemical composition of Normal urine**

<b>Constituent</b>	<b>Daily excretion in grams</b>
water	1200.00
Urea	30.00
Uric acid	0.70
Hippuric acid	0.70
Creatinine	1.20
Oxalic acid	0.02
Allantoin	0.04
Amino acid nitrogen	0.20
Purine bases	0.01
Chloride as NaCl	12.00
Sodium	4.00
Potassium	2.00
Calcium	0.20
Magnesium	0.15
Sulphur, total as S	1.00
Inorg. Sulphates as S	0.80
Neutral Sulphur as S	0.12
Conjugated sulphates as S	0.08
Phosphates as P	1.10
Ammonia	0.70
Sugar	0.00

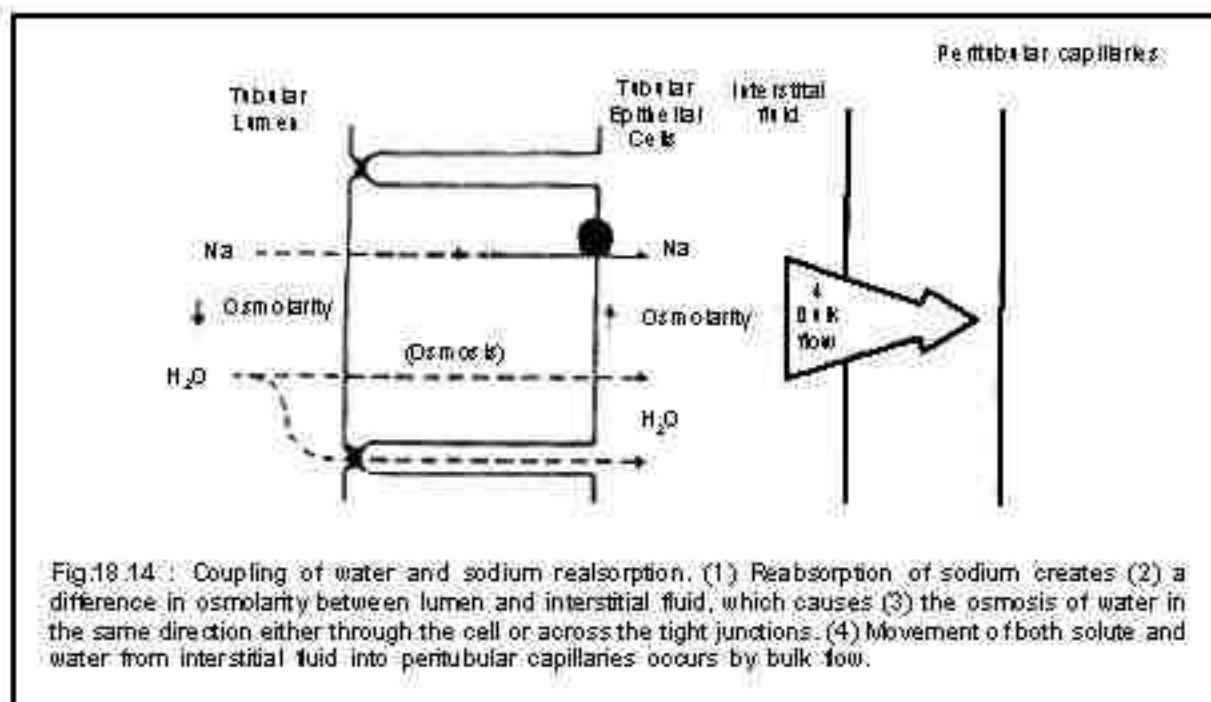

### 18.5. ROLE OF KIDNEY IN OSMOREGULATION :

Osmoregulation is the control of water level in the body. When there is excess of water in the body kidney produces large volume of dilute urine and brings the water level to correct position. In the event of deficiency of water, kidney helps to conserve body water by producing small volume of concentrated urine. Kidney produces large quantity dilute urine by reducing tubular reabsorption of water due to absence of ADH.

The ability of the human kidneys to produce a hyperosmotic urine enables the body to survive without water for a long period. The human kidneys can produce a maximal urinary concentration of 1400 m osmol/L., almost five times the osmolarity of the blood plasma; which is 300 m osmol /L. Urea, sulfate, phosphate and other waste products and ions excreted each day amount to approximately 600 m osmol / L. Hence, a minimum volume of water in which the above quantity of solute can be dissolved and excreted in the urine is

$$= \frac{600 \text{ mOsmol/day}}{1400 \text{ mOsmol/L}} = 0.444 \text{ L/day}$$

This volume of urine is known as the 'obligatory water loss'. The loss of this minimal volume of urine contributes to dehydration when a person goes without water for a long period.

Sodium and water usually move together. Whenever, water is lost sodium is lost with it. The major factor determining the rate of tubular reabsorption is **aldosterone**.

The maintenance of the plasma sodium level at a steady state is controlled by the steroid hormone aldosterone from the adrenal cortex which also influences water reabsorption. A decrease in blood sodium leads to a decrease in blood volume because less water enters the blood by osmosis. This in turn reduces blood pressure. The decrease in pressure and volume stimulates a group of secretory cells of the juxtamedullary apparatus situated between the distal convoluted tubule and the afferent arteriole of the glomerulus to secrete a hormone renin. Renin activates a protein angiotensinogen synthesised by liver to angiotensin which is a strong stimulator of aldosterone. Aldosterone is carried by blood to the distal convoluted tubule of the kidney. Here, it stimulates the sodium - potassium pumps in the cells of the tubules resulting in more sodium ions being pumped out of the distal convoluted tubule into the peri-tubular capillaries around it. Potassium moves in the opposite direction.

Aldosterone also stimulates sodium absorption in the gut and decreases loss of sodium in sweat, both these effects tend to raise blood sodium level. This in turn causes more water to enter the blood by osmosis, raising its volume and pressure. This process is called RAAS (Renin - angiotensin aldosterone system).

Although aldosterone is the most important controller of sodium reabsorption, another peptide hormone known as atrial natriuretic factor (ANF) which is synthesised and secreted by cells of cardiac atria. ANF acts on the kidneys to inhibit sodium reabsorption. It also inhibits the secretion of both renin and aldosterone, which results in less sodium reabsorption. Secretion of ANF is increased when there is an excess of sodium in the body; the stimulus being an increase in atrial distension.

## 18.6. ROLE OF OTHER ORGANS IN EXCRETION :

### 18.6.1. Role of lungs :

Human lungs eliminate around 18 litres of  $\text{CO}_2$  per hour and about 400 ml of water per day in normal resting condition. Water loss via the lungs is small in hot humid day climate and large in cold dry climates. The rate of ventilation and ventilation pattern (i.e. breathing through mouth or nose) also affect the water loss through the lungs.

### 18.6.2. Role of skin :

Human skin possesses glands for secreting two fluids on its surface, viz, sweat from sweat glands and sebum from sebaceous glands. Sweat is an aqueous fluid (around 99.5% water) containing NaCl, lactic acid, urea, amino acids and glucose. Depending upon activity and temperature, 14 litres sweat per day is formed, whose main function is to cool the body by evaporation. Sebum is a waxy protective secretion to keep the skin oily and this secretion eliminates some lipids, hydrocarbons and fatty acids.

### 18.6.3. Role of Liver :

Liver is the main site of elimination of cholesterol, bile pigments (bilirubin and biliverdin), inactivated products of steroid hormones, some vitamins and many drugs. Liver secretes these substances in bile, which in turn, carries these materials into the intestine, which are ultimately eliminated with the faeces.

Table - 18.4

#### Secondary excretory organs and miscellaneous excretory products

Excretory Organs	Products eliminated	
	Primary	Secondary
Kidneys	Water, nitrogenous wastes from protein catabolism and inorganic salts	Heat and Carbon dioxide
Lungs	Carbon dioxide	Heat and water
Skin	Carbon dioxide, water, salts and urea	
Alimentary canal	Solid wastes and secretions	Carbon dioxide, water, salts and heat

#### Abnormal products in the urine :

**Glucose** - The presence of glucose in the urine is called glycosuria. The most common cause of glycosuria is a high blood sugar level. Kidney tubules fail to reabsorb all this excess quantity of glucose from the glomerular filtrate and some of it is excreted along with urine.

**Erythrocytes** - The appearance of red blood cells is called haematuria. One cause of haematuria is an acute inflammation of the urinary organs as a result of disease of irritation from kidney stones.

**Leucocytes** - The presence of leucocytes and other components of pus in the urine, referred to as pyuria indicates infection in the kidney or other urinary organs.

### 18.7. DISORDERS RELATED TO EXCRETION :

#### 18.7.1. Uremia :

Accumulation of the nitrogenous waste products of metabolism in the blood as a result of the kidneys to excrete them (kidney failure). The effects include nausea, vomiting, oedema, itching, spontaneous bleeding, anaemia, confusion, seizures etc. the uremic syndrome can be defined as the terminal clinical manifestation of kidney failure. It is the signs, symptoms

and results from laboratory tests which result from inadequate excretory regulatory and endocrine function of the kidney. Classical signs of uremia are progressive weakness, muscular dystrophy etc.

### 18.7.2. Renal failure :

Renal failure is a medical condition in which the kidneys fail to adequately filter waste products from the blood. The main forms are acute kidney injury, which is often reversible with adequate treatment and chronic kidney disease, which is often not reversible in both cases, there is usually an underlying cause.

In kidney failure, there may be problems with increased fluid in the body, increased acid levels, raised levels of potassium, decreased level of calcium, increased levels of phosphates, and in later stages in anaemia. Long term kidney problems are associated with increased risk of cardiovascular diseases.

#### (a) Symptoms :

A High level of urea in the blood, which can result in :

- Vomiting and / or diarrhoea
- Weight loss
- Nocturnal urination
- More frequent urination or in greater amounts than usual
- Blood in the urine
- Pressure or difficulty in urination
- Swelling of the leg, face and hands
- Appetite loss
- Difficulty sleeping

#### (b) Causes

Acute Kidney injury - It usually occurs when the blood supply to the kidneys is suddenly interrupted or the kidneys become overloaded with toxin. Causes include accidents, injuries or complications from surgery in which kidneys are deprived of normal blood flow for extended periods of time. During overdoses, accidental or from chemical overloads of drugs such as antibiotics or chemotherapy, may also cause the onset of acute kidney injury.

### 18.7.3. Renal Calculi (Kidney Stone)

A kidney stone, also known as renal calculus or nephrolith, is a solid piece of material, which is formed in the kidneys from minerals in urine. If stones grow to sufficient size (usually at least 3 millimeters (0.1 in), they can cause blockage of the ureter. This leads to pain, most commonly beginning in the flank or lower back and often radiating to the groin. The associated symptoms are nausea, vomiting, fever, blood in the urine, pus in the urine and painful urination.

Most stones form due to a combination of genetics and environmental factors. The diagnosis is usually based on symptoms, urine testing and medical imaging. High dietary intake of animal protein, sodium, refined sugars, oxalate, grapefruit juice and apple juice may increase the risk of kidney stone formation. The excessive dietary intake of Vitamin-C might increase the risk of calcium oxalate stone formation.

#### 18.7.4. Nephritis :

Nephritis is the inflammation of the kidney and may involve the glomeruli, tubules or interstitial tissue surrounding the glomeruli and tubules. It is 2 types

1. Glomerulonephritis is the inflammation of the glomerules
2. Interstitial nephritis is the inflammation of the spaces between renal tubules.

#### (a) Causes

Nephritis is often caused by infections and toxins, but is most commonly caused by autoimmune disorders that affects the major organs like kidneys.

#### (b) Mechanism

Nephritis can produce glomerular injury, by disturbing the glomerular structure with inflammatory cell proliferation. As the kidneys inflame, they begin to excrete needed protein from the body into the urine stream. This condition is called proteinuria. Loss of necessary protein due to nephritis can result in several life-threatening symptoms. The most serious complications of nephritis can occur if there is significant loss of the proteins that keep blood from clotting excessively. Loss of these proteins can result in blood clots causing sudden stroke.

#### 18.7.5. ADH deficiency and Diabetes insipidus :

It is called antidiuretic hormone or vasopressin. This is secreted by the posterior lobe of pituitary gland. In the presence of ADH the walls of DCT, CT and CD become permeable to water and water is reabsorbed. This causes formation of concentrated urine and conservation of water in the body. More of ADH is secreted during summer season. Reabsorption of water in the presence of ADH is facultative reabsorption. Deficiency of ADH leads to production of large quantity of urine called **Diabetes insipidus**.

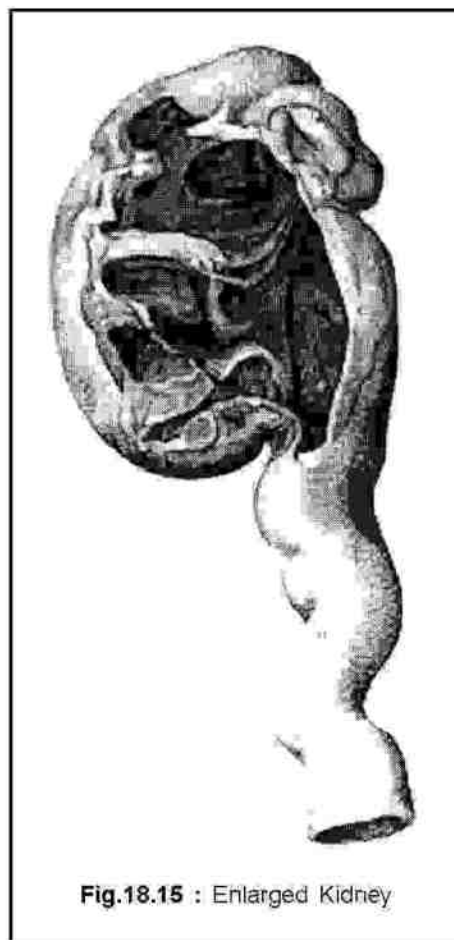

Fig.18.15 : Enlarged Kidney



**Diuretics**

Drugs used to increase the volume of urine excreted are known as diuretics. Such agents act by inhibiting the reabsorption of sodium along with chloride and / or bicarbonate resulting in increased excretion of these ions. Since water reabsorption is dependent upon sodium reabsorption water reabsorption is also reduced resulting in increased water excretion. Diuretics are used to treat diseases characterised by renal retention of salt and water. Another common use of diuretics is in the treatment of hypertension. The diuretics are classified according to the mechanism by which they inhibit ion reabsorption except for one category of diuretics, the potassium sparing ones, all other diuretics not only increase sodium excretion but also cause increased potassium excretion also, which can be an unwanted side-effect. One category of diuretics blocks the action of aldosterone by competing with its receptors on the tubule cell membrane. There are different categories of diuretics include carbonic anhydrase inhibitors, loop diuretics, thiazides, potassium- sparing diuretics that show different mechanisms of action and have different sites of action in the nephron.

**18.7.6. Dialysis :**

The failing kidneys reach a point when they can no longer excrete water and ions at rates that maintain body balance of these substances nor they can excrete the wastes as fast as they are produced. Dietary changes can minimize these problems but such alternations cannot eliminate these problems. The techniques used to replace the kidney's functions are called dialyses (dialysis sing.) Dialysis means separation of substances using a semi or a selectively permeable membrane.

Dialysis can be of two types, **haemodialysis and peritoneal dialysis.**

**(a) Haemodialysis :**

This kind of dialysis involves the use of an artificial membrane in a 'kidney machine'. It functions as an artificial kidney on the same principle as the real kidney. The blood is pumped out of the body, filtered to remove the waste materials, a process called dialysis and then returned. The patient is connected to the machine by inserting a catheter (a hollow tube-like needle) into an artery in the arm or the leg connecting this to a flexible tube leading to the machine and then returning the washed blood into a vein.

The blood is pumped gently out of the artery and returned to the vein. Heparin is added to the blood to prevent clotting. The blood circulates slowly through the dialysis tubing which is an artificial semi-permeable membrane which allows ions, very small molecules and water to diffuse through it. Blood cells, platelets and protein molecules are too large to escape from the patient's blood. The tubing is bathed on the outside by a dialysing solution which has the correct ionic balance, particularly  $\text{Na}^+$ ,  $\text{K}^+$ ,  $\text{Cl}^-$ ,  $\text{Mg}^{++}$ ,  $\text{Ca}^{++}$  and  $\text{HCO}_3^-$ ; additional nutrients, such as glucose which help to maintain the correct solute potential, the correct pH and buffers maintained at  $37^\circ\text{C}$ . Periodically, the dialysing fluid is removed and replaced by fresh fluid. Unwanted substances are removed, particularly urea and excess sodium and potassium and needed substances are held back. The process is simpler than that of the

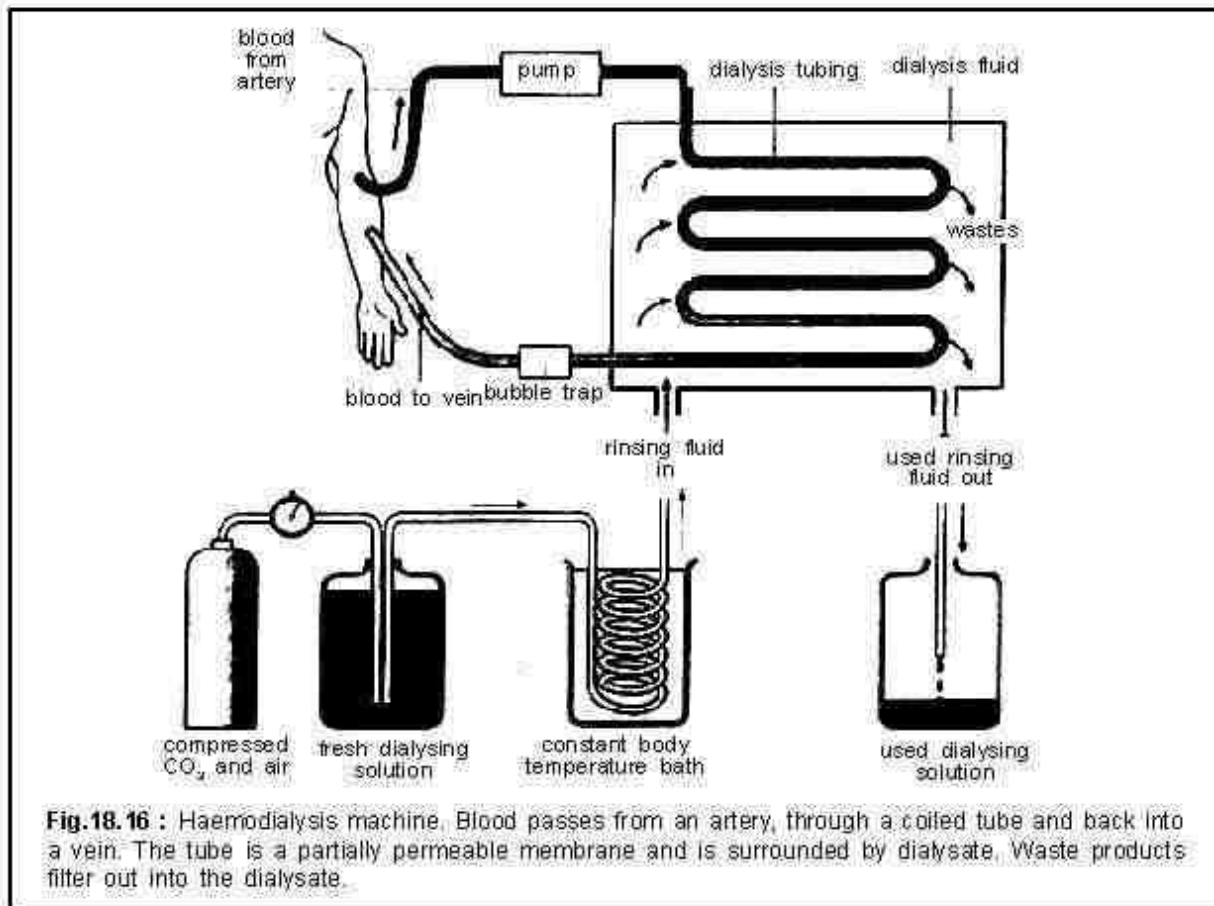

real kidney because ultrafiltration does not occur and reabsorption of useful substances is not necessary.

The process takes 6 to 8 hours and is usually done atleast twice a week. Patients with chronic irreversible renal failure require treatment for the rest of their lives or till they receive a kidney transplant. Such patients undergo hemodialysis several times a week, often at home.

**(b) Peritoneal Dialysis - use of peritoneum, a natural membrane :**

Another way of removing excess substances from the blood is peritoneal dialysis; which uses the lining of the person's own abdominal cavity (peritoneum) as a dialysing membrane. A thin plastic tube is inserted into the abdominal cavity through a small slit in the abdomen wall. The peritoneal membrane which lines the abdominal cavity acts as a dialysing membrane. Dialysing fluid is added to the abdominal cavity through the tube and left for several hours before it is removed. Exchange of material takes place between the tissue fluid in the abdomen and the dialysing fluid. The dialysing fluid is replaced 3 or 4 times a day. In between, the patient can remain mobile and relatively, free to lead a normal life. For this reason, it is described as **continuous ambulatory peritoneal dialysis or CAPD**. Many patients prefer this to haemodialysis in which they have to remain attached to a kidney machine. The method is also cheaper and simpler. The only disadvantage with this method is the risk of infection.

**SAMPLE QUESTIONS****GROUP - A****(Objective-type Questions)****1. Choose the correct answer :**

- (i) The organs of excretion in the cockroach are  
(a) Flame cells (b) Green gland  
(c) Nephridia (d) Malpighian tubules
- (ii) Birds eliminate their nitrogenous wastes in the form of  
(a) ammonia (b) urea  
(c) uric acid (d) amino acid
- (iii) Ornithine cycle occurs in  
(a) liver (b) kidney  
(c) brain (d) skin
- (iv) Ornithine cycle synthesizes  
(a) ammonia (b) urea  
(c) uric acid (d) Xanthine
- (v) What is the main nitrogenous waste product in reptile ?  
(a) ammonia (b) urea  
(c) uric acid (d) hippuric acid
- (vi) Urea is formed from the breakdown of  
(a) carbohydrates (b) proteins  
(c) fats (d) nucleic acids
- (vii) In man, uric acid is formed from the break down of  
(a) carbohydrates (b) proteins  
(c) fats (d) nucleic acids
- (viii) Desert mammals have ——— in their nephrons.  
(a) Long loops of Henle (b) long proximal convoluted tubules  
(c) long distal convolutions (d) long collecting ducts
- (ix) ADH exercises its action on ——— part of the nephron.  
(a) PCT (b) Henle's loop  
(c) DCT (d) glomerulus
- (x) Most aquatic animals are  
(a) ammonotelic (b) ureotelic  
(c) uricotelic (d) aminotelic

- (xi) What is diabetes insipidus due to ?  
(a) loss of glucose by the urine, (b) deficiency of ADH  
(c) deficiency of insulin (d) all of the above
- (xii) Which hormone is secreted from juxtaglomerular apparatus of kidney ?  
(a) renin (b) angiotensin  
(b) adrenalin (d) calcitrol
- (xiii) Reabsorption of sodium and chloride occurs in  
(a) Ascending limb of Henle's loop, (b) proximal convoluted tubule  
(c) descending limb of Henle's loop (c) Distal convoluted tubule)
- (xiv) Human kidney is  
(a) pronephric (b) mesonephric,  
(c) metanephric (d) opisthonephric
- (xv) Longer loop of Henle is meant primarily for increased absorption of  
(a) glucose (b) water  
(c) potassium (d) aminoacids

#### GROUP - B

##### (Short Answer-type Questions)

1. Write briefly on the following (within 50 words each) :

- (i) Ammonotelism
- (ii) Ureotelism
- (iii) Uricotelism
- (iv) Role of the Malpighian tubule in the excretion in cockroach.
- (v) Structure of the mammalian nephron
- (vi) Ultrafiltration
- (vii) Selective reabsorption
- (viii) Henle's loop
- (ix) Counter current mechanism
- (x) Kidney as an endocrine organ
- (xi) Secretion
- (xii) Acid-base balance
- (xiii) Role of liver in excretion
- (xiv) Ornithine cycle / Urea cycle
- (xv) Dialysis

- (xvi) Storage excretion in cockroach
  - (xvii) Renin - angiotensin system
  - (xviii) Obligatory water loss
2. Explain the following :
- (i) Net filtration pressure
  - (ii) Glomerular filtration rate
  - (iii) Obligatory reabsorption of water
  - (iv) Role of ADH in water reabsorption
  - (v) Obligatory water loss
  - (vi) Functions of vasa recta
3. Differentiate between.
- (i) Ammonotelism and Ureotelism
  - (ii) Ureotelism and Uricotelism
  - (iii) Cortical nephron and juxamedullary nephron
  - (iv) Selective reabsorption and secretion
  - (v) haemodialysis and peritoneal dialysis
  - (vi) Acute renal failure and chronic renal failure
  - (vii) Ammonotelism and Aminotelism
  - (viii) Descending limb of Henle's loop and Ascending limb of Henle's loop
  - (ix) Obligatory and Facultative reabsorption of water
4. Explain the location of the following :
- (i) Renal columns of Bertini
  - (ii) Duct of Belini
  - (iii) Macula densa
  - (iv) Vasa recta

#### GROUP - C

#### (Long Answer-type Questions)

1. Give an account of the structure of the human kidney.
2. Give an account of the structure and functions of the human kidney.
3. Give an account of the mechanisms of urine formation.
4. Give an account of the role of the human kidney in osmoregulation.



A large number of animals are free moving i.e. they are displaced at will from time to time. The phenomenon of changing displacement with time is known as locomotion. The purpose of locomotion is threefold. Firstly, an animal performs locomotion in search of new food source. Secondly, it defends itself from its enemies and inclement weather conditions. It also offends animals of other species and even of its own species to maintain supremacy. Finally, it breeds to give rise to off springs of its own species, which are displaced to another place to avoid overcrowding and shortage of food and shelter. On the contrary, quite a few animals are sedentary i.e. they are attached to a substratum throughout their life. They are not displaced, but exhibit bending and swaying movements only. The disadvantages of becoming sedentary are partly overcome by having free swimming larvae. A larva swims away from its original location, settles down at a new location and undergoes metamorphosis to become sedentary again. A cell, which constitutes the building block of life also exhibits movement. The protoplasm exhibits streaming movement in a defined way. Alternately speaking, where there is life, there is movement. Locomotion is executed by specialized structures. In unicellular organisms, these structures are parts of the same cell i.e. sub-cellular structures and hence, are called **locomotor organelles**. In multicellular animals, these structures are multicellular and therefore, are termed as **locomotor organs**.

### **19.1. TYPES OF MOVEMENT :**

Different types of movements are executed in different animal groups. However, the ones like ciliary, flagellar and muscular are discussed hereunder. Ciliary and flagellar movements are classed under a broader heading, **swimming**. These movements are executed by solitary cells, especially in cilia and flagella bearing protozoa.

#### **19.1.1. Swimming (ciliary and flagellar) Movement :**

Protozoa of the classes, Ciliata (e.g. *Paramecium*) and Flagellata (e.g. *Euglena*) execute this of movement. The locomotor organelles are thin and delicate protoplasmic threads, known as cilia and flagella. The microscopic structures of flagellum and cilium are essentially similar except for the size and number. A cilium is shorter and more numerous than a flagellum. The classification of the class, Ciliata is based on the arrangement of cilia. In *Paramecium*, for example, cilia are present all over the cell. On the other hand, in *Vorticella*, the cilia are confined to the some parts of the cell (Fig. 19.1).

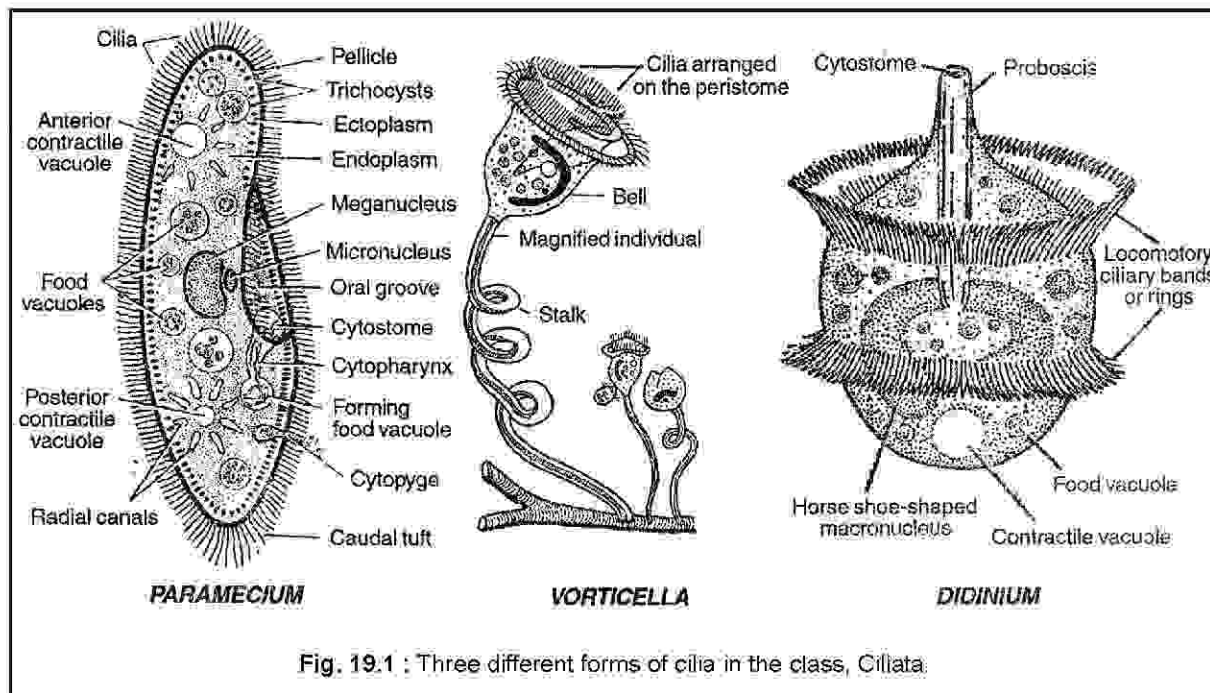

Fig. 19.1 : Three different forms of cilia in the class, Ciliata.

Similarly the forms of flagellum are also diverse. There is a single, backwardly directed flagellum in *Euglena*. The number may be two or more, in some reaching a number of four (e.g.

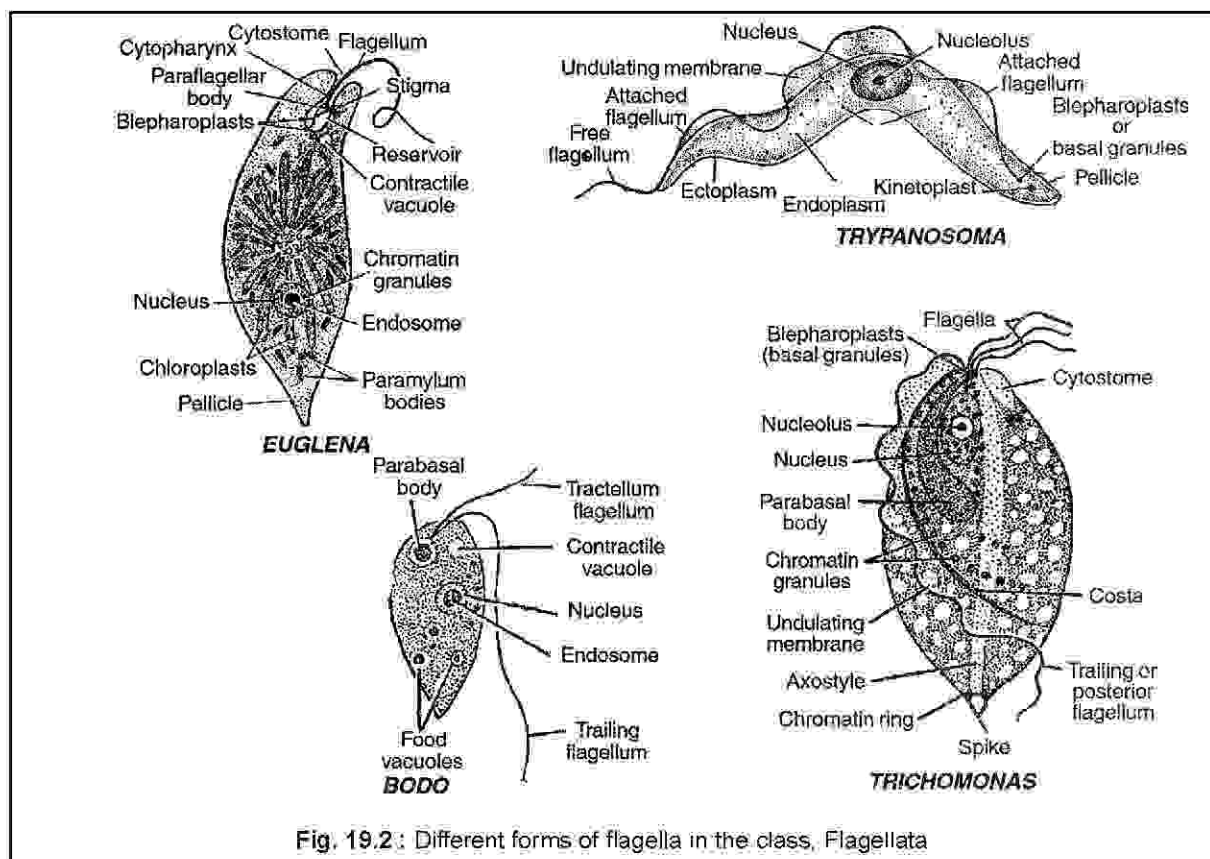

Fig. 19.2 : Different forms of flagella in the class, Flagellata

*Trichomonas*). In this situation, one flagellum, known as the trailing flagellum is backwardly directed. The rest, known as tactella (singular tactellum) are forwardly directed. In some flagellates (e.g. *Trypanosoma*) the flagellum adheres to the pellicle for most part of its length. When the flagellum undulates, the pellicle is drawn out as an ultra thin membranous structure, known as undulating membrane (Fig. 19.2).

#### 19.1.1.1. Structure of flagellum / cilium :

A flagellum or a cilium is a thin and delicate microscopic protoplasmic process protruding from the surface of a cell. In a gross structure, it consists of a fiber-like central axis, called axoneme, surrounded by a protoplasmic sheath. Electron microscopic structure (Fig.19.3) reveals that the axoneme is made up of a bundle of microtubules in a defined arrangement.

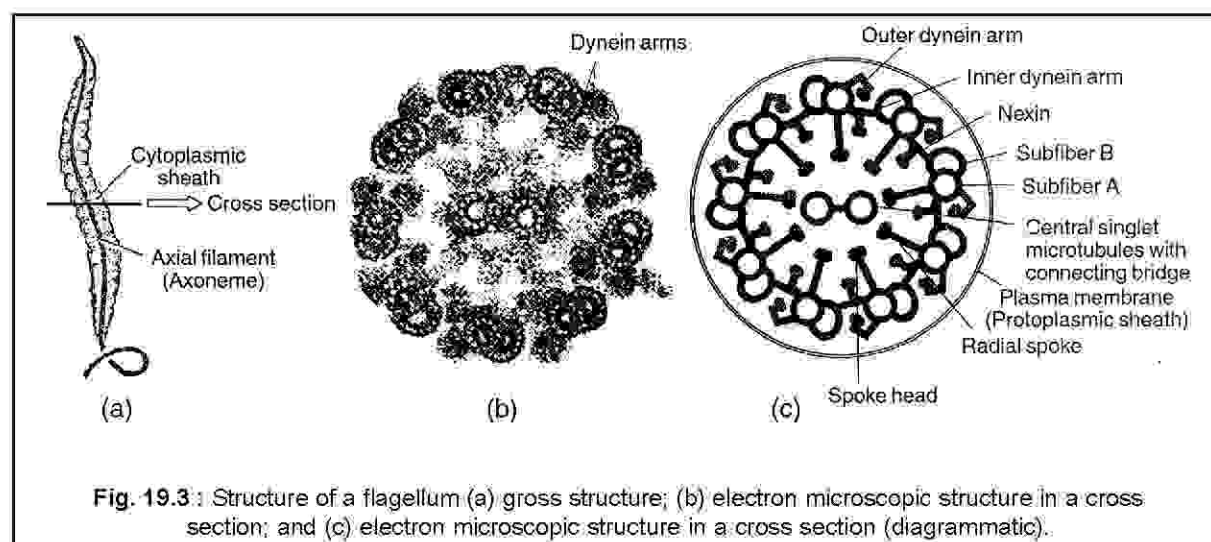

Fig. 19.3: Structure of a flagellum (a) gross structure; (b) electron microscopic structure in a cross section; and (c) electron microscopic structure in a cross section (diagrammatic).

1. There are two central microtubules surrounded by nine peripheral microtubular bundles. Each peripheral microtubular bundle consists of two closely adhering microtubules.
2. The central microtubules are known as **singlets**, while the peripheral ones as **doublets**.
3. Each singlet consists of 13 protofilaments.
4. Two singlets are joined by a connecting bridge.
5. Each doublet consists of two closely adhering microtubules, subfiber A and subfiber B. Subfiber A has 13 protofilaments, while subfiber B has 10-11.
6. Subfibers A are joined to the singlets by radial spokes, each terminating in a knob-like spoke head.
7. Doublets are joined by circumferential **nexin protein**. Each subfiber A bears two **dynein protein arms**: an outer and an inner. Each dynein arm ends in a knob-like head.



The dynein arm acts much like the cross bridge of myosin protein filament in a skeletal muscle. It attaches to the subfiber B of the adjacent doublet and slides over it in a similar fashion to that of a sarcomere of the skeletal muscle. Thus, a flagellum / cilium contracts and relaxes alternately and brings about locomotion.

**19.1.1.2. Mechanism of flagellar / ciliary locomotion:**

The flagella / cilia are contractile protoplasmic threads due to the presence of microtubules. These contract and relax rhythmically in response to external stimuli. This rhythmic beating is known as **undulation**. The flagellum / cilium is held rigidly and bends to one side. Accompanied by bending, undulations pass from the tip to the base. In doing so, it strikes the water like an oar. Mechanical energy is generated, which propels the animalcule a little forward. This stroke is known as **effective stroke** [Figs.19.3 (a) & 19.4 (a)]. Following the completion of the effective stroke, the flagellum / cilium returns back to its normal position in a relaxed manner. This constitutes another stroke, known as **recovery stroke** [Figs.19.3 (b) & 19.4 (b)].

There is a single flagellum in *Euglena*. Therefore, it is propelled forward in a **screwed or spiral manner** [Fig.19.6 (a)]. However, in *Paramecium*, there are numerous cilia, arranged in

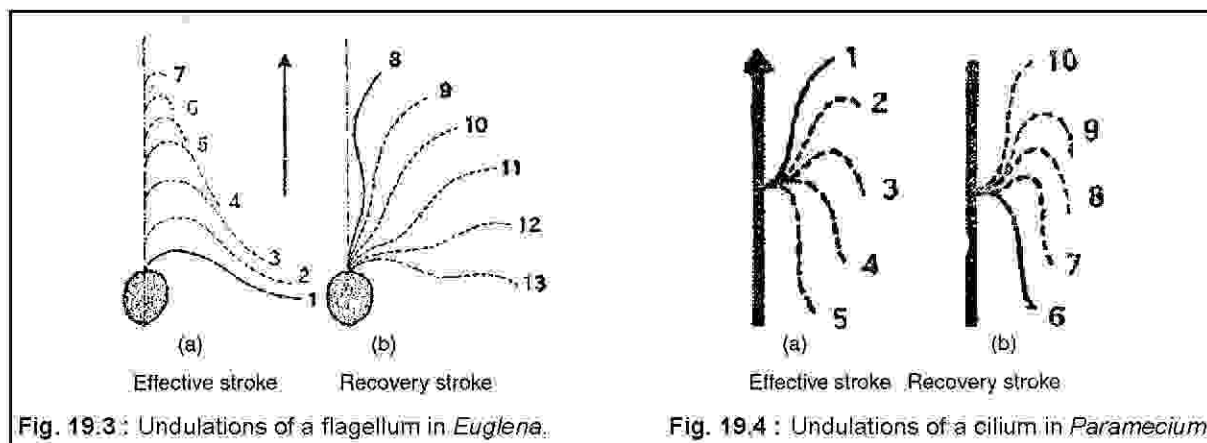

two rows: transverse and longitudinal. The transverse rows of cilia undulate all at the same time causing a **synchronous rhythm**. Those of the longitudinal rows undulate at different times) causing **metachronous rhythm** (Fig.19.5).

The beating of the cilia generates mechanical energy, which propels *Paramecium* in a forward direction. Like *Euglena*, it also follows a spiral path, due to the presence of more cilia on

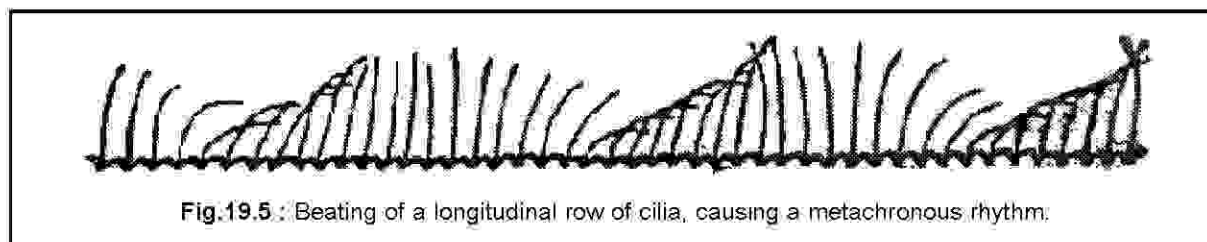
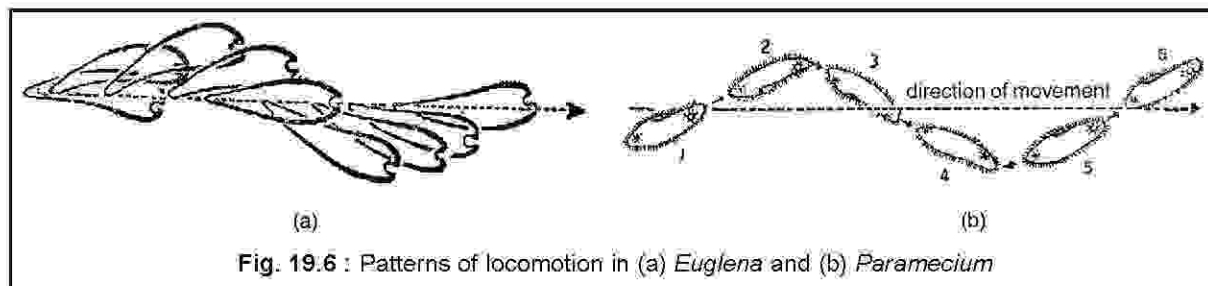

Fig.19.5 : Beating of a longitudinal row of cilia, causing a metachronous rhythm:



the oral groove side [Fig. 19.6 (b)]. The caudal tuft of paramecium acts as a rudder and helps change the direction as and when necessary.

### 19.1.2. Muscular movement:

Locomotion in human occurs by the co-ordinated contraction and relaxation of skeletal muscle. A muscle contracts only when it is stimulated by a somatic motor neuron. The axon of neuron makes a special junction at the sarcolemma of a skeletal muscle fiber, known as a **neuro-muscular junction**. The neuron, when stimulated releases a neurotransmitter chemical at the junction. This chemical acts as a signalling substance which brings about changes in the electric potential across the membrane of the muscle fiber. Following this, chemical and physical changes occur in the fiber, which end up in its contraction. For a better understanding of these changes, it is necessary to have a close look at its structure.

## 19.2. STRUCTURE OF SKELETAL MUSCLE :

### 19.2.1. Structure :

Skeletal muscle, as the name indicates, is attached to the elements of the skeletal system, such as bones and cartilages. A skeletal muscle is surrounded by a connective tissue sheath, the **epimysium**. The muscle is made up of bundles of elongated and cylindrical muscle fibers, known as **fasciculi**. Each fasciculus is surrounded by a sheath, known as **perimysium** and each muscle fiber is surrounded by an **endomysium** (Fig.19.7). **A muscle fiber consists of many myofibrils and each myofibril consists of two types of protein myofilaments: actin and myosin** (Figs.19.9 and 19.11). A skeletal muscle fiber is a multinucleate elongated cell (**syncytium**) with a surrounding **sarcolemma**. The bulk of the fiber is occupied by **myofibrils**. This results in the displacement of the active sarcoplasm with the nuclei to the peripheral part. Each myofibril is surrounded by an extensive network of endoplasmic reticulum, known as **sarcoplasmic reticulum** and **mitochondria**. The sarcoplasmic reticulum is in the form of tubules, which join to form **terminal cisternae**, present between each anisotropic (A) and isotropic (I) bands. The sarcolemma invaginates between each A and I bands to form a **transverse tubule**. The sarcoplasmic reticulum in the form of tubules and terminal cisternae and transverse tubules constitute a **sarco-tubular system** (Fig.19.8).

### 19.2.1.1. Structure of myofibril (Fig.19.9) :

In a stained microscopic preparation, the myofibrils are seen to exhibit alternating dark and light bands. The dark staining bands are known as **anisotropic bands (A bands)**, while the light staining bands are known as **isotropic bands (I bands)**. A myofibril contains two types of protein myofilaments : **thick filaments (myosin)** and **thin filaments (actin)**. These filaments contribute towards the bulk structure of the myofibril. The filaments are arranged in a periodic manner. This arrangement gives rise to the alternating A and I bands at regular intervals which imparts a **striated appearance** to the skeletal muscle. The same periodicity is found in all the muscle fibers of a fasciculus, thus giving the muscle a **cross-striated** or **striped appearance** [Figs. 19.10 (a) & (b)].

A thick line called **Z-line** [Z is for a German word, *zwichenschiebe* (*zwischen*, between; *schiebe*, disc)] runs across the middle of each I band. The middle of each A band is traversed by a lighter band called the **H-band** (H is for Hensen, who first described it).

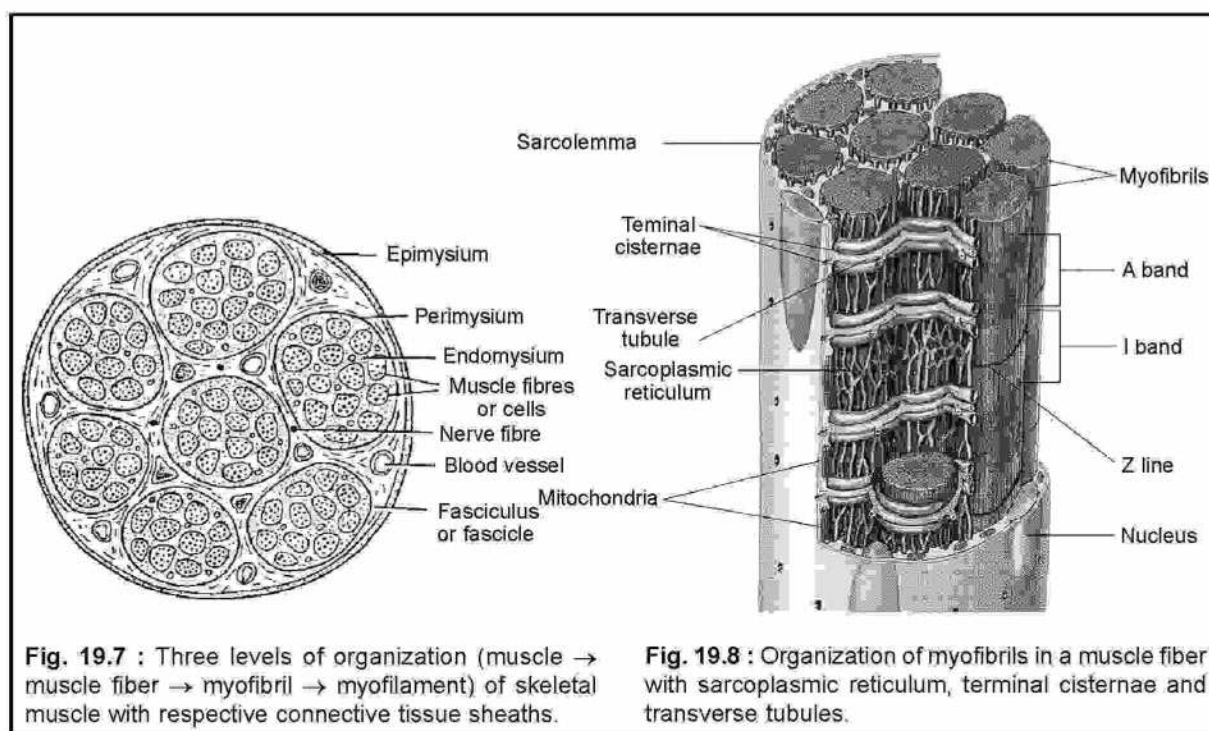

Running through the centre of the H-band, there is a thin **M-band** [M is for a German word, *mittleschiebe* (*middle*, between; *schiebe*, disc)]. The stretch of the muscle fiber between two Z-lines is called a **sarcomere**. The sarcomere is considered as the **contracting unit** of the muscle fiber. The nerve innervating a muscle enters into it at a place called the **neuromuscular hilus**.

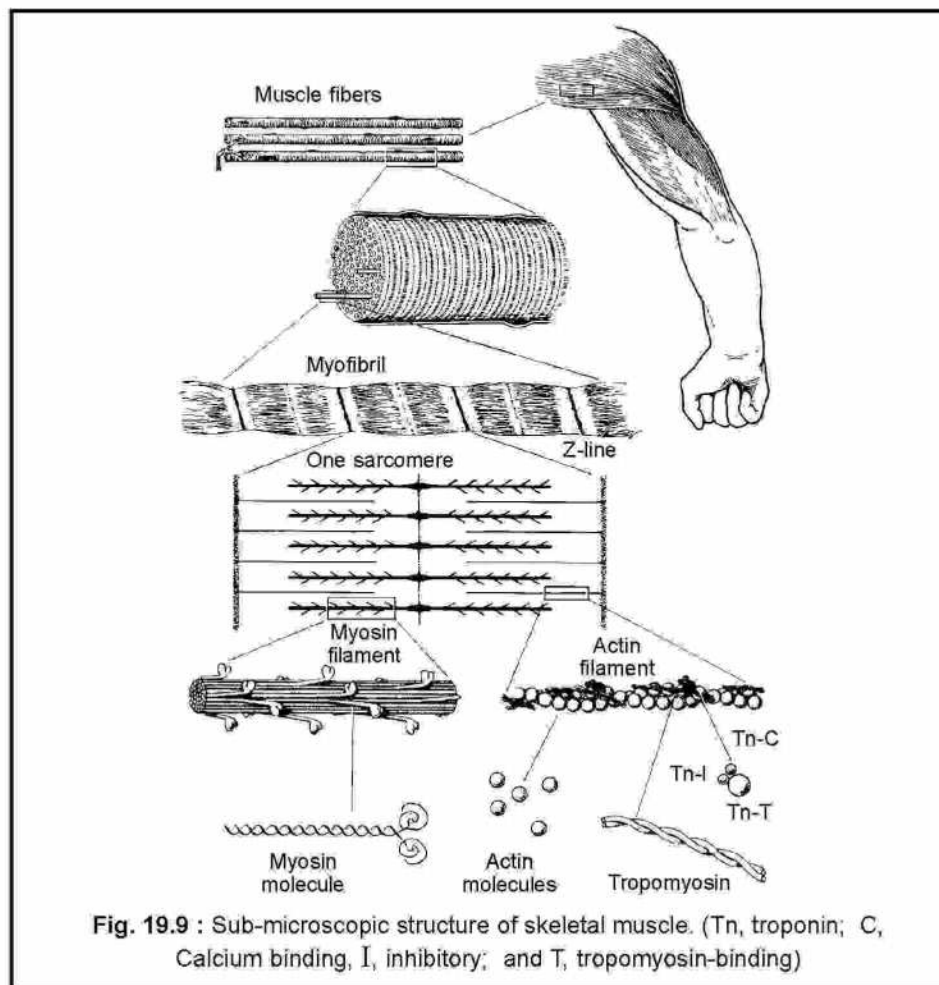
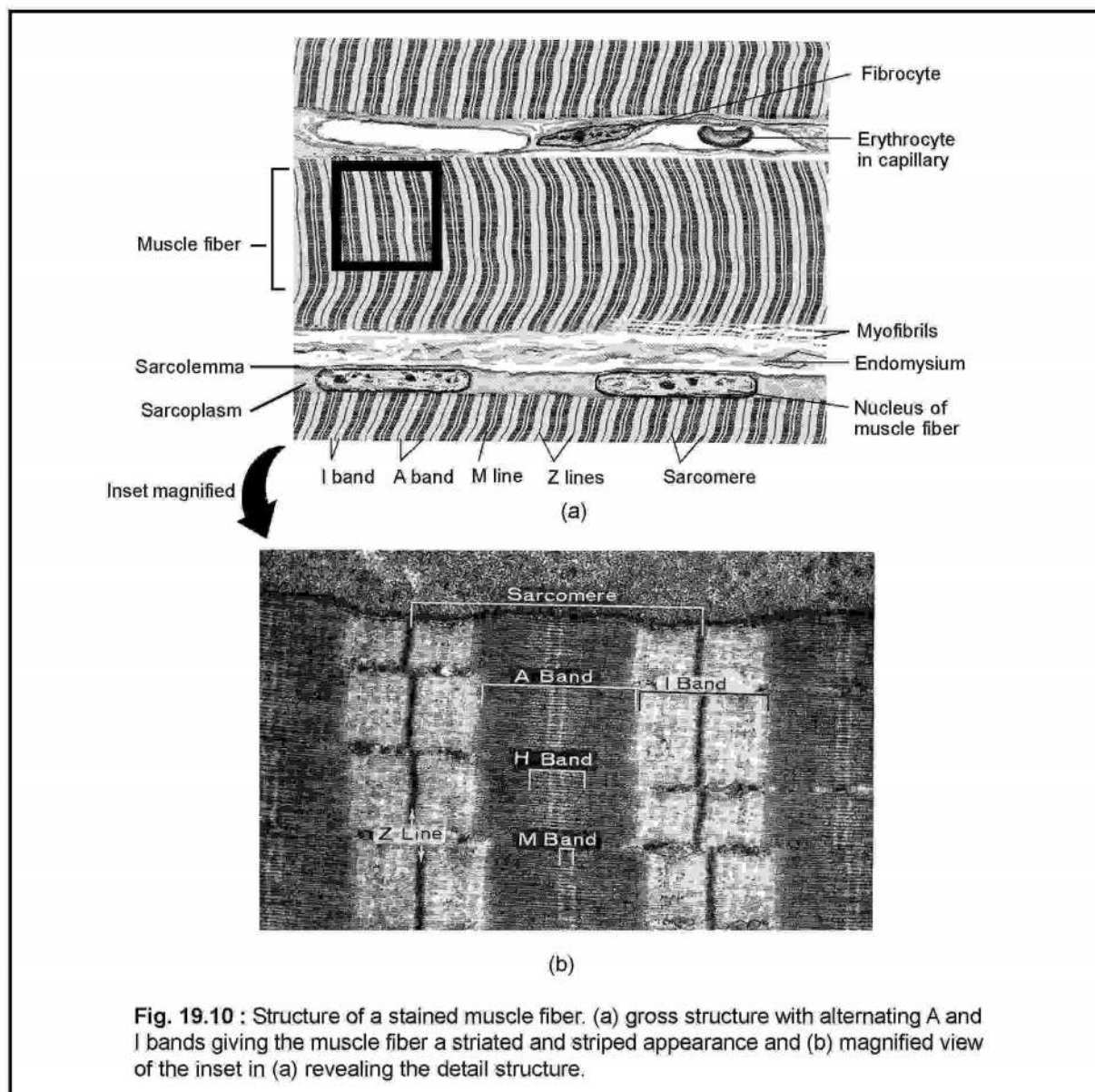

Fig. 19.9 : Sub-microscopic structure of skeletal muscle. (Tn, troponin; C, Calcium binding, I, inhibitory; and T, tropomyosin-binding)

#### 19.2.1.2. Structure of myofilaments (Fig. 19.11) :

Two main types of myofilaments, such as **myosin** and **actin** are present in the myofibril.

**Myosin** [Fig. 19.11 (c)] : A thick or myosin filament consists of several myosin molecules organized into a bundle that gives it a thick filamentous appearance. Each myosin molecule has two **heavy polypeptide chains**, associated with two pairs of **light polypeptide chains**. The heavy chains are helically coiled around each other. At the N-terminus of each heavy chain, the polypeptide is globular forming a **head**. The head has an ATPase activity, which binds to and hydrolyzes ATP to generate mechanical energy during muscle contraction. The myosin molecules are oriented in opposite directions in two halves of the thick filament so that in the middle of the thick filament, there is no head and thus, this part has a lighter band-like appearance, which runs across a muscle fiber. This band has been referred to as the **H-band**. Running through the middle of each H band, there is a relatively thinner M-band or line.



**(a) Actin** [Fig. 19.11 (b)] : A thin or actin filament consists of two actin chains, helically coiled around each other. Each actin chain consists of a linear array of many actin molecules. An actin molecule is a **globular protein** and thus, is known as **globular actin** or **G-actin**. A G-actin molecule has an ATPase activity and a myosin head binding site. Several G-actins join linearly forming a **fibrous actin** or **F-actin**. Two F-actins helically coil forming an actin filament. During muscle contraction, the myosin heads bind to the G-actin's myosin head binding sites. ATP, bound to the myosin heads are hydrolyzed by the ATPase activity. Mechanical energy is generated, which slides the F-actin and Myosin over each other. Thus the muscle contraction is effected.

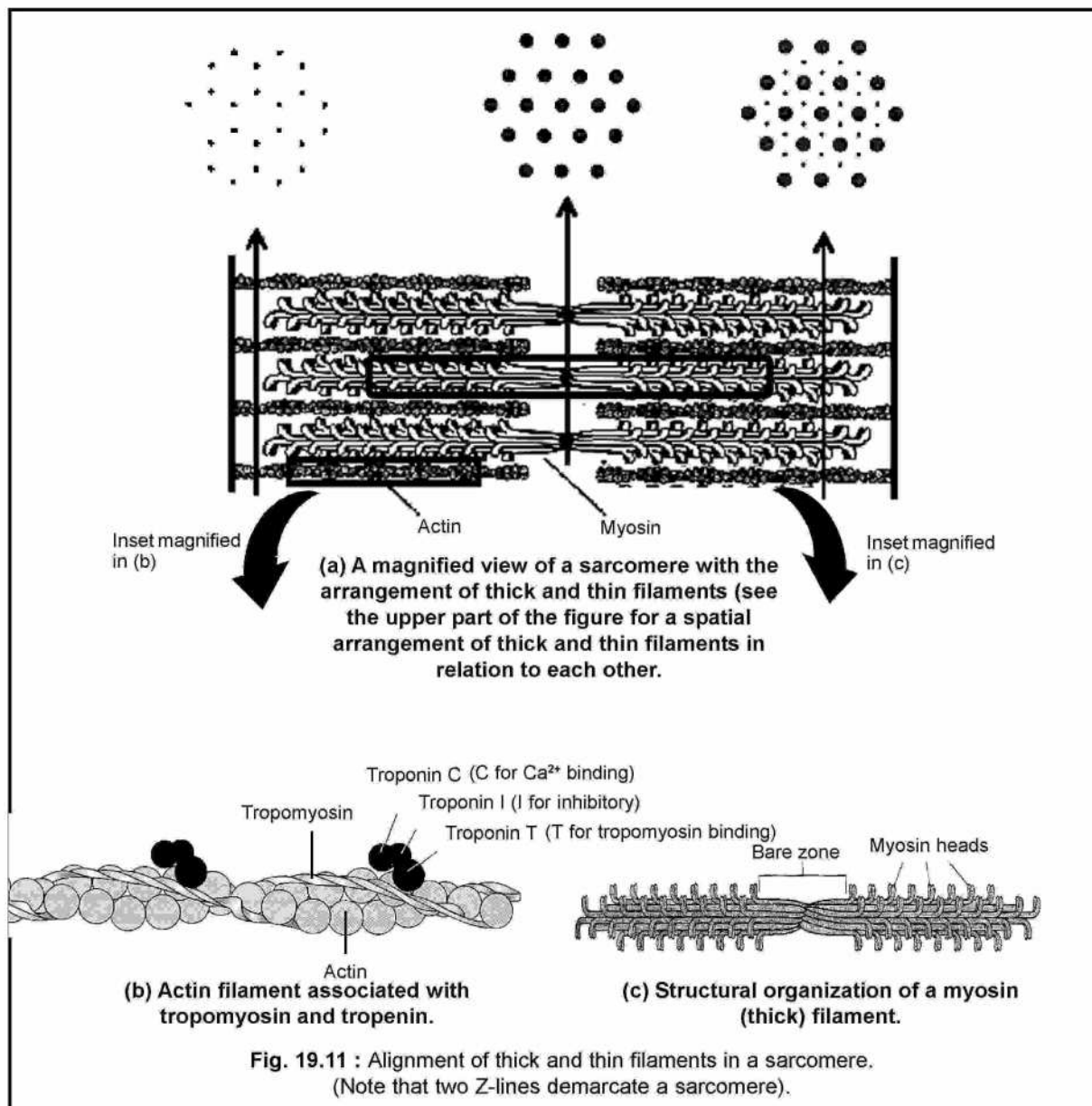

There is a regularity in the arrangement of myosin and actin filaments. A myosin filament is surrounded by six actin filaments [Upper part of Fig. 19.11 (a)]

The actin and myosin filaments are not free floating. The thin filaments are anchored to the Z-line by a protein, called **actinin**. The thick filaments are anchored to the Z-line and M-line by a protein, called **titin** (Fig. 19.12). Two other proteins, known as **troponin** and **tropomyosin** also play an important role in muscle contraction. Troponin is a globular protein consisting of three subunits : TnC (Ca<sup>2+</sup> binding subunit), TnI (inhibitory subunit) and TnT (tropomyosin-binding subunit). Tropomyosin is a fibrous protein which covers the myosin head binding sites in the actin in a resting muscle fiber. The role of these proteins in muscle

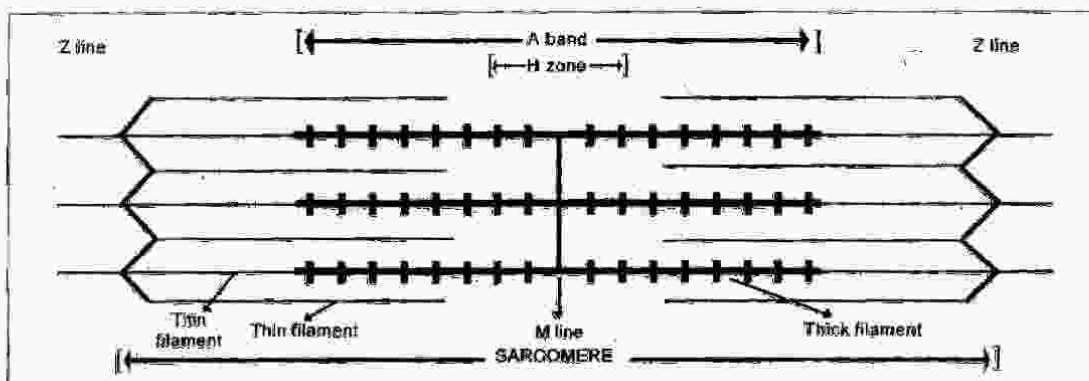

Fig. 19.12 : Organization of a sarcomere with titin filaments anchoring thick (myosin) filaments to Z-lines

contraction is discussed in the section, 19.3.1. at point 2 on locomotion and movement in man. (see the section : on muscle contraction).

**19.3. MECHANISM OF MUSCLE CONTRACTION :**

The protein myofilaments present in the myofibril form the physical basis of muscle contraction. The actin and myosin filaments slide past over each other to effect the contraction process. Consequently, the sarcomere shortens i.e. the distance between two Z-lines decreases. A close examination reveals that the length of the filaments does not change. The I-bands and H-zones, containing only thin and thick filaments, respectively, get shorter during contraction. The length of A-band remains unaffected [Figs.19.13 (a) & (b)]. The mechanism that explains skeletal muscle contraction is known as **sliding filament mechanism**, proposed by **H. E. Huxley and J Hanson, A. F. Huxley and R. Niedergerke**

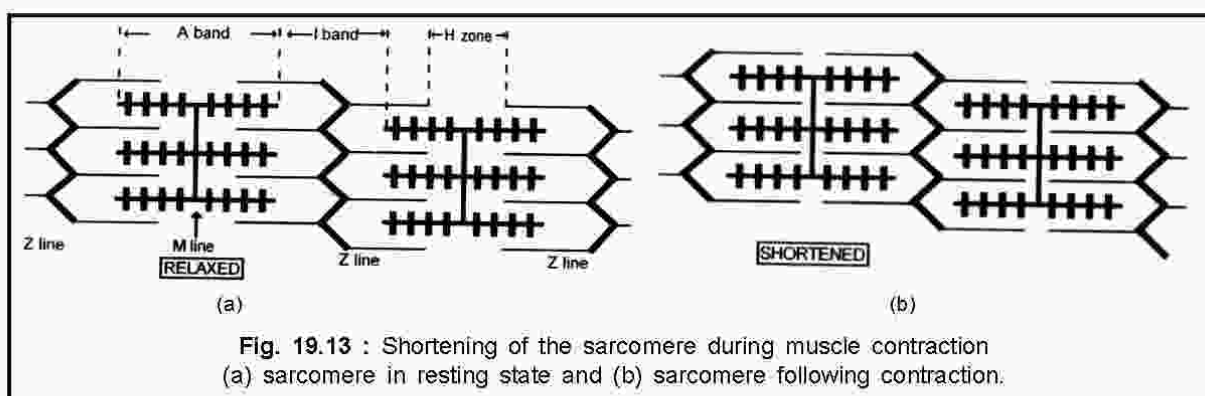

Fig. 19.13 : Shortening of the sarcomere during muscle contraction (a) sarcomere in resting state and (b) sarcomere following contraction.

**19.3.1. Biochemical events during muscle contraction (Fig.19.14) :**

1. The muscle contraction is initiated when the axon terminals of an excitatory motor nerve, innervating the muscle is stimulated and then releases a **neurotransmitter** chemical at the nerve-muscle (neuro-muscular) junction. A neurotransmitter is a

chemical signal, which when released changes the electric potential in the sarcolemma of the muscle fibers of the contracting muscle like every other biological membrane. The sarcolemma has a resting electric potential across it. This is known as **resting membrane potential**. Under the influence of the neurotransmitter, the resting membrane potential in a local area of the sarcolemma is reversed. This generates a potential difference or **action potential (AP)** across the membrane. The generation of an action potential is known as **membrane depolarization**. The AP then propagates to the membrane of the sarcoplasmic reticulum, which causes the calcium ion ( $\text{Ca}^{2+}$ ) channels to open. Consequently  $\text{Ca}^{2+}$  are released from the sarcoplasmic reticulum lumen into the sarcoplasm. This event initiates the contraction of the muscle fiber.  $\text{Ca}^{2+}$  will remain in the sarcoplasm as long as the contraction continues. Following an inhibitory stimulus the  $\text{Ca}^{2+}$  reaccumulate in the sarcoplasmic reticulum by an active transport mechanism. This process is catalyzed by  **$\text{Ca}^{2+} - \text{Mg}^{2+}$  ATPase**. Following a phase of contraction, if the movement of  $\text{Ca}^{2+}$  into the reticulum is inhibited, relaxation doesn't occur. This condition of sustained contraction is known as **contracture**.

2. The released  $\text{Ca}^{2+}$  bind to the troponin C subunit of troponin. This weakens the binding of troponin I to the actin filament and subsequently, dislodges it. Then the tropomyosin moves laterally, consequently freeing the myosin head binding sites of actin.
3. An ATP binds to the ATP binding site of the myosin head. It is hydrolyzed into ADP and  $\text{P}_i$  by the ATPase activity. Following the hydrolysis, the myosin head binds to its binding site in each G- actin and forms a cross bridge. The  $\text{P}_i$  is then released. This causes a conformational change in the myosin, causing the cross bridge to produce a **power stroke**.
4. After the power stroke, the bound ADP is released and a new ATP binds to the myosin head. The release of ADP and binding of another ATP is necessary to break its bond with the actin after the completion of a power stroke.

ATP is required to dislodge ADP. In the absence of ATP, the ADP remains bound to the myosin head. Consequently, the myosin heads remain permanently bound to actin and this means that the muscle is never relaxed. This condition is known as **rigor mortis**. It occurs after death, when there is a complete depletion of ATP and **phosphocreatine**.

### 19.3.2. Energy sources :

The immediate source of energy for contraction is ATP, produced in carbohydrate, protein and lipid catabolism. However, during heavy exercise, ATP may be used faster than it is produced. A rapid renewal of ATP is extremely necessary to keep the contraction process on. Under this situation **phosphocreatine**, a reserve energy currency in mitochondria of



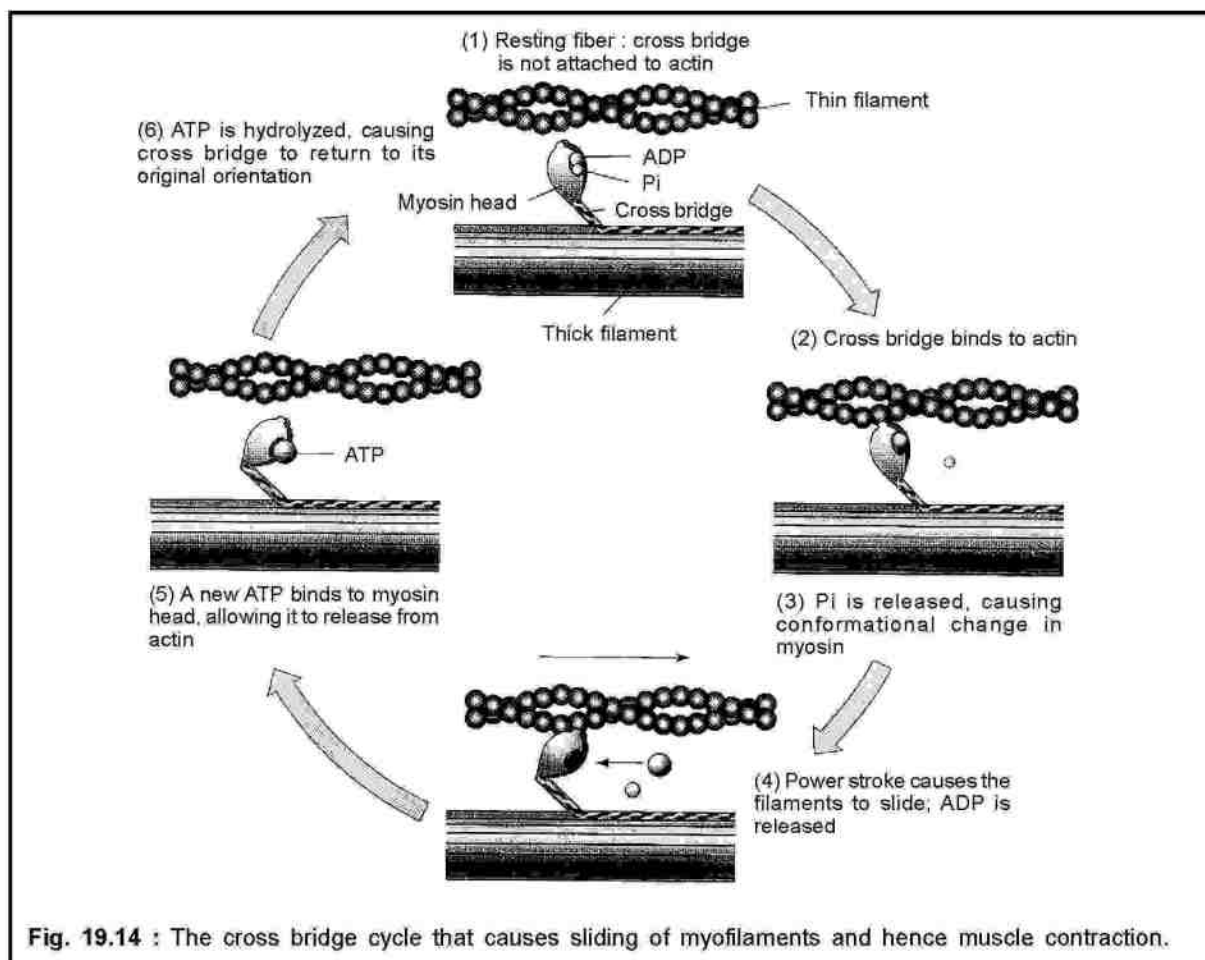

**Fig. 19.14** : The cross bridge cycle that causes sliding of myofilaments and hence muscle contraction.

muscle fibers, serves to form ATP. This energy-rich compound transfers its phosphate group to ADP, consequently forming ATP. This phosphate transfer reaction is catalyzed by an enzyme called **creatine kinase**, also called **creatine phosphokinase**, present in the skeletal muscle fiber. When the muscle is at rest, ATP in the mitochondrion transfers its phosphate group to creatine forming phosphocreatine. Thus, there is a build up of phosphocreatine to serve during exigency. Its concentration is more than three times the concentration of ATP in a muscle cell.

**Types of skeletal muscle fibers** : Skeletal muscle fibers are divided, on the basis of their contraction speed, into **slow twitch** or **type I fibers** and **fast twitch** or **type II fibers**. Slow twitch fibers have a rich capillary supply, numerous mitochondria, aerobic respiratory enzymes and a high concentration of **myoglobin**. Myoglobin is a red pigment similar to haemoglobin. It helps deliver oxygen to these fibers. Because of their high myoglobin content, these fibers are also termed as **red fibers** (e.g.; soleus muscle of the leg and long muscles of the back). Fast twitch fibers have fewer capillaries and mitochondria than slow twitch fibers. These fibers do not contain as much myoglobin as those of the slow twitch fibers and hence, are termed as **white fibers** (e.g.; extra-ocular muscles of the eye).

### 19.3.3. Cori Cycle :

The ATP that drives muscle contraction is generated through oxidative phosphorylation in mitochondria-rich **slow-twitch muscle fibers** or by **catabolism of glucose** into lactic acid in **fast-twitch muscle fibers**. (For slow twitch and fast twitch muscles see the box in the previous page). In heavily exercising slow-twitch muscle fibers, the demand of ATP exceeds its supply. In this situation, these fibers produce lactic acid from glucose by lactic acid fermentation (anaerobic respiration). This lactic acid is transported to the liver via the blood. Here, it is converted into pyruvic acid and then to glucose by gluconeogenesis. The synthesized glucose returns to the muscle, where it is stored as glycogen during rest or catabolized immediately to generate ATP for muscle contraction. The cycle serves as a means for the replenishment of depleted glycogen in heavily exercising muscle fibers. This two-way traffic between the skeletal muscle and liver is known as **Cori cycle**, (Fig. 19.15), named in the honour of Carl Cori and Gerty Cori, who first described it.

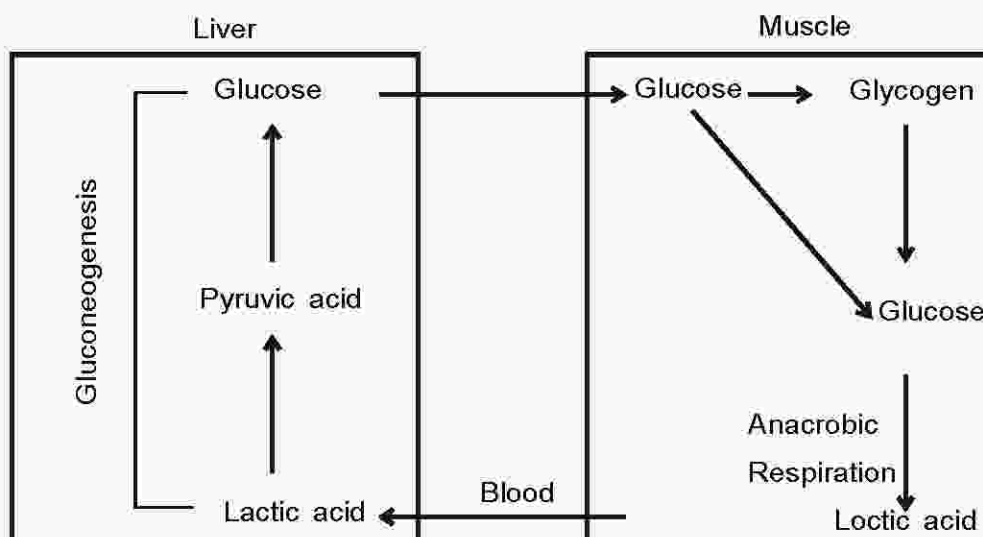

Fig. 19.15 : Cori Cycle (Two-way traffic between skeletal muscle and liver)

## 19.4. HUMAN SKELETAL SYSTEM :

Human body has a definite shape and an up-right posture. This is possible due to the presence of an endoskeleton of bones and cartilages. It constitutes the internal supporting frame of the body in human and other vertebrates.

The human body contains 206 bones, which are organized in two groups: **axial skeleton** consisting of the bones of the skull, vertebral column, sternum and ribs and **appendicular skeleton**, consisting of the limb bones and girdles (Fig. 19.16).

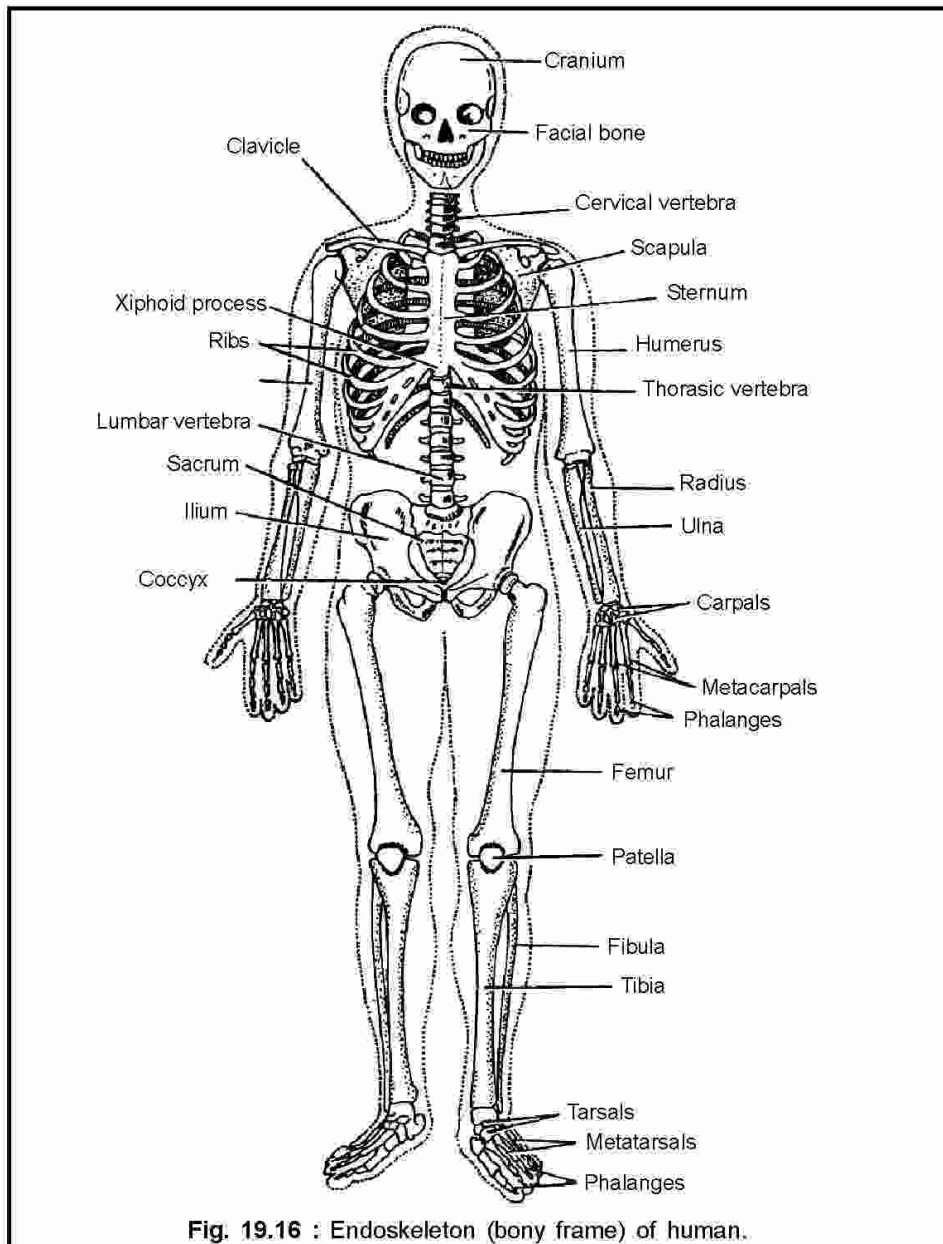

Fig. 19.16 : Endoskeleton (bony frame) of human.

#### 19.4.1. Axial skeleton (Fig 19.17):

It is named so, because of its presence along the main axis of the body. It has **80 bones**, of which **28 irregular-shaped** including **bones of middle ear** and **brain box** or **cranium** are in the skull and **33 in the vertebral column**. The rest are the ribs and the bones of the sternum.

The vertebral column is made by several vertebrae, articulated with each other linearly forming a flexible column. There are **seven cervical, twelve thoracic, five lumbar, five sacral** (fused to form a **sacrum**), and **four vestigial caudal vertebrae**. The caudal vertebrae,

together, constitute a **coccyx**. The thorax or chest harbours a thoracic cavity, supported by twelve thoracic vertebrae on the dorsal side and twelve pairs of **thoracic ribs**. All the ribs articulate with thoracic vertebrae at the back. However, ten out of the twelve pairs, articulate with the sternum on the ventral side, while 11th and 12th pairs articulate only with the thoracic vertebrae. These do not articulate with the sternum and hence are called **floating ribs**.

#### 19.4.2. Appendicular skeleton :

It consists of **126 bones of the limbs, hip and the shoulder**. Limb bones include those of the **fore limbs (arms) and hind limbs (legs)**. The bones at the shoulder and hip regions constitute **pectoral and pelvic girdles**, respectively. The fore limb bones (Fig. 19.18) are **humerus (upper arm); radius and ulna (fore arm); carpals (wrist); metacarpals; and phalanges (hand)** in a proximal to distal direction. There are **eight carpals** in the wrist; **five slender metacarpals** and **fourteen phalanges** in the hand. The phalanges are organized into five fingers. There are three phalanges, each in all fingers, than the thumb, which has only two. The proximal end of humerus articulates with the **glenoid cavity** of pectoral girdle in a **ball and socket joint**.

The hind limb bones (Fig. 19.19) are **femur (thigh); tibio-fibula (shank); and tarsals, metatarsals, and phalanges (ankle and foot)** in a proximal to distal direction. Except the proximal two, the tarsals and all metatarsals and phalanges constitute the foot. There are **seven tarsals**, out of which two proximals constitute the **ankle bone (astragalus and calcaneum)**. The tarsals are followed by **five slender metatarsals** and **fourteen phalanges**. The phalanges are organized into five fingers or toes. There are three phalanges, each in all toes, except the big toe, which has only two. The proximal end of femur articulates with the **acetabulum** of the pelvic girdle in the same ball and socket joint as that of the head of humerus.

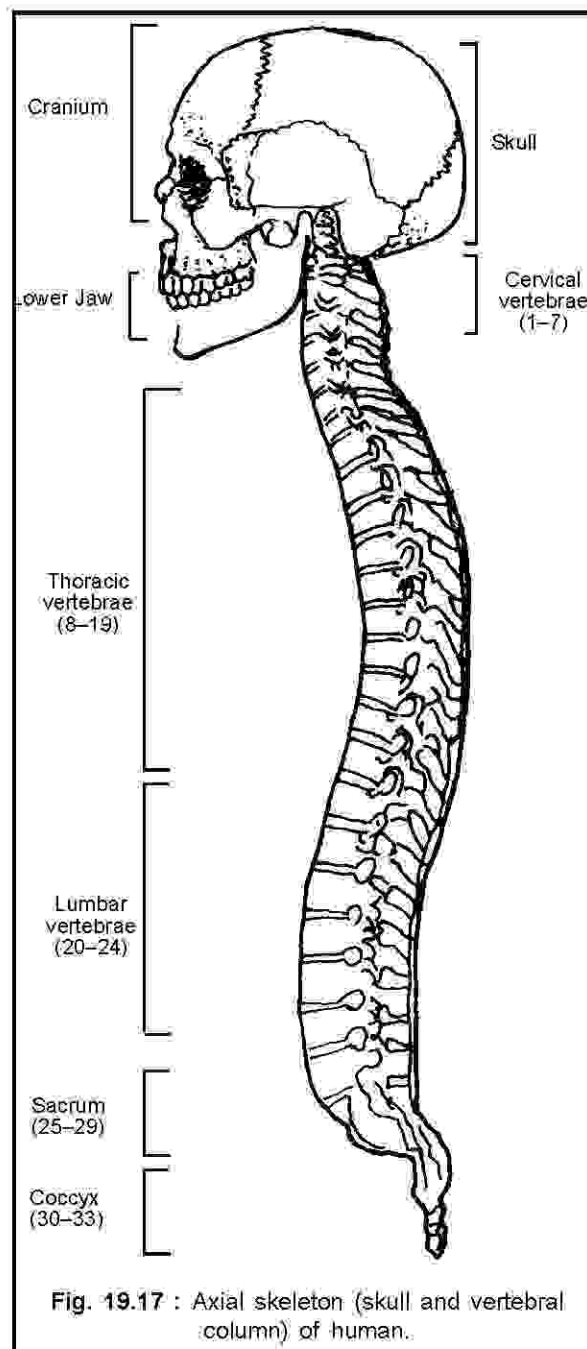
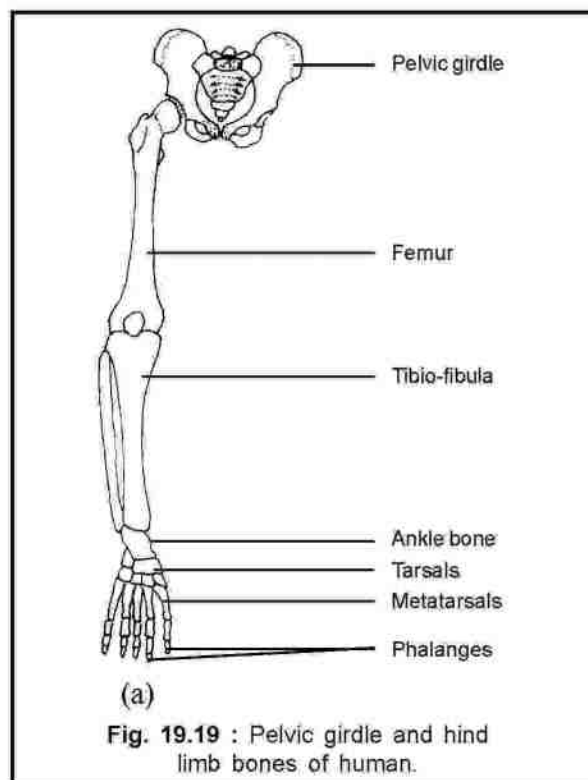
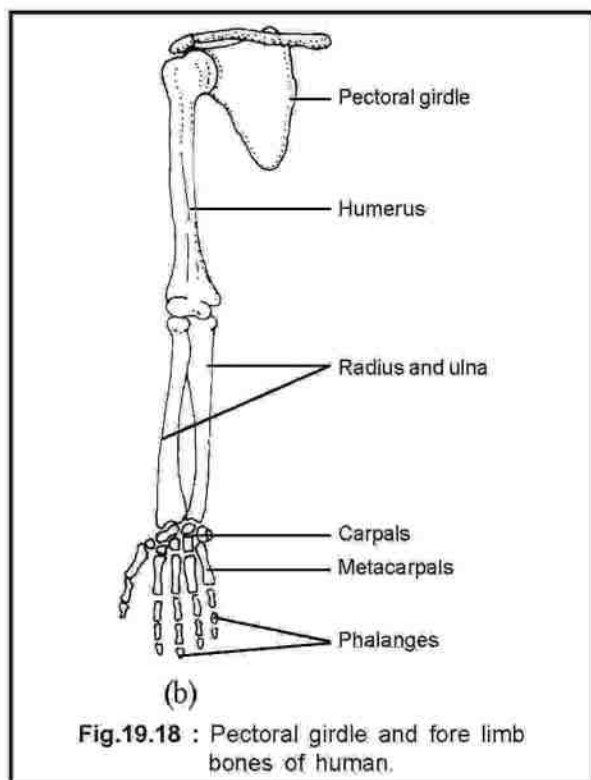

Fig. 19.17 : Axial skeleton (skull and vertebral column) of human.



**19.4.3. Joints :**

The skeletal elements articulate with each other in a definite manner and give rise to a flexible frame of the body. The site, where two skeletal elements come together, is known as a **joint**. The degree of free movement of bones is largely determined by the nature of the joints. Two general types of joints have been recognized: (1) **synovial** or **diarthrose** [Fig. 19.20 (a)] and (2) **solid** or **synarthrose** [Fig.19.20 (b)].

**19.4.3.1. Synovial (Diarthrose) joint (Fig. 19.21) :**

Each articular surface is covered by a layer of **hyaline cartilage**. Two surfaces are separated by a narrow **articular cavity**. A **joint capsule**, formed by an inner **synovial membrane** and an outer **fibrous membrane**, is present at the place of articulation. The synovial membrane is attached to the margin of each articular surface at the interface between the cartilage and bone. This membrane is vascular and produces a

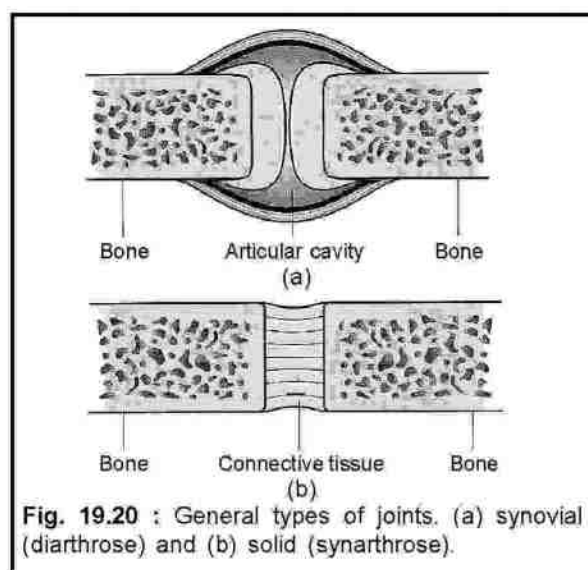

**synovial fluid**, which fills in the articular cavity. Synovial fluid is **dialyzed blood plasma**, to which is added **hyaluronic acid** by the synovial membrane. It acts as a lubricant at the articular surface and thus absorbs friction.

The fibrous membrane, consisting of dense connective tissue that surrounds the joint. Parts of the fibrous membrane may thicken to form ligaments. Such ligaments provide additional reinforcements to the joint. Occasionally, **fibrocartilage articular discs**, **fat pads** and **tendons** are enclosed by the articular cavity. These structures act as shock absorbers during the movement of bones at the joint. Based on the axis of movement, these are described as: **(a) uniaxial**, **(b) biaxial**, and **(c) multiaxial**.

**(a) Uniaxial** : This joint has one degree of freedom i.e. the articulating bones can move in one axis only. It is again classified as: **(i) hinge or ginglymus**, **(ii) pivot or trochoid**, and **(iii) bicondylar joints**. In hinge joint (Fig.19.22), the movement is along a transverse axis. One articular surface is convex and the other concave. The two surfaces are joined by strong collateral ligaments (e.g.; interphalangeal joints of fingers and toes; elbow and ankle joints).

In pivot joint, the movement is along a vertical axis. One bone acts as a pivot, on which the other exhibits rotational movement (e.g.; atlas-axis joint).

In bicondylar joint, one surface has two contact points known as condyles. The movement is mainly along a transverse axis but partly also along a vertical axis (e.g.; knee joint).

**(b) Biaxial** : The two articulating bones move along transverse and vertical axes. It is classified as: **(i) condylar or ellipsoid**, and **(ii) saddle** joints. In ellipsoid joint, one articular surface is concave, while the other is convex. The convex surface is elliptical in outline (e.g.; radio-carpal joint; metacarpo-phalangeal joint; and atlas-occipital condyle joint).

In saddle joint, the opposing articular surfaces are concave convex in a reciprocal manner. The movement is similar to that of

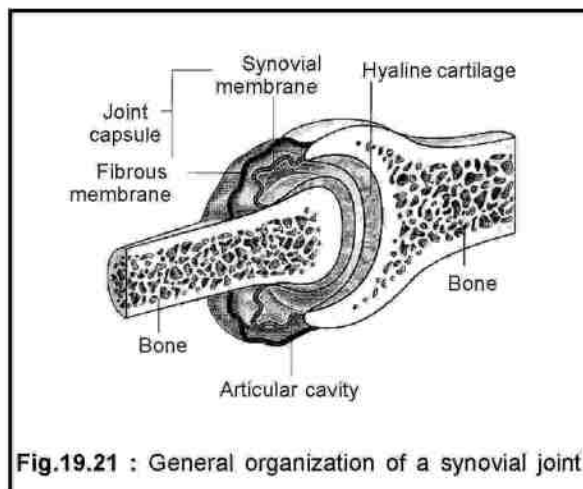

Fig.19.21 : General organization of a synovial joint

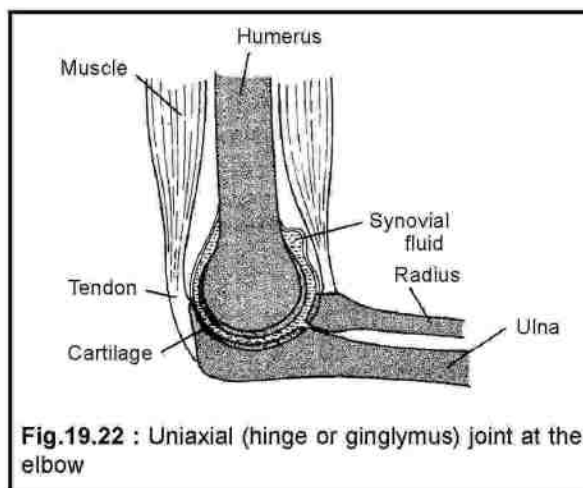
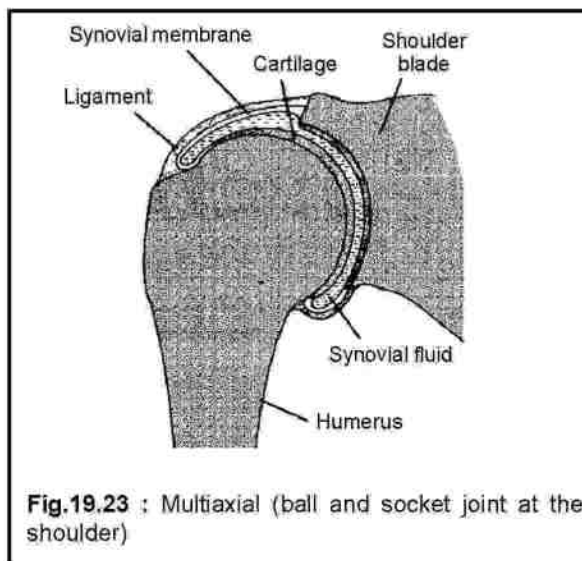

Fig.19.22 : Uniaxial (hinge or ginglymus) joint at the elbow

condylar or ellipsoid joint, however, some degree of rotation is also allowed (e.g.; carpo-metacarpal joint of thumb and sternum-clavicle joint).

**(c) Multiaxial :** The movement is possible along all axes. It includes the only joint i.e. **ball and socket** or **spheroidal joint**. One articular surface is convex, while the other is concave. The concave surface is socket-like, into which articulates the ball-like convex articular surface (Fig.19.23). The movement of one bone takes place along all three independent axes: transverse, antero-posterior, and vertical (e.g.; shoulder and hip joints)



**Fig.19.23 :** Multiaxial (ball and socket joint at the shoulder)

#### 19.4.3.2. Solid (Synarthrose) joint :

It is a joint between two skeletal elements, connected by **fibrous connective tissue** or **cartilage**, especially, **fibrocartilage**. Movements at these joints are more restricted than at synovial joints. It is of two types: (a) **fibrous** and (b) **cartilaginous**.

**(a) Fibrous joints:** No movement is allowed at this joint. Fibrous joints include: (i) sutures, (ii) gomphoses, and (iii) syndesmoses.

**(i) Sutures (Fig. 19.24) :** The adjacent bones are joined by thin layers of connective tissue, called sutural ligaments. (e.g.; skull bones)

**(ii) Gomphoses (singular;**

**gomphosis) (Fig. 19.25) :** It is characterized only in the articulation of the tooth root in the bony socket. Short collagen fibers of the **periodontal ligament** run between the root and the bony socket. (e.g.; tooth-socket articulation)

**(iii) Syndesmoses (singular; syndesmosis) (Fig. 19.26) :** The adjacent bones articulate by a ligament. The radius articulates with the ulna by an **interosseous membrane**. (e.g.; radius and ulna articulation)

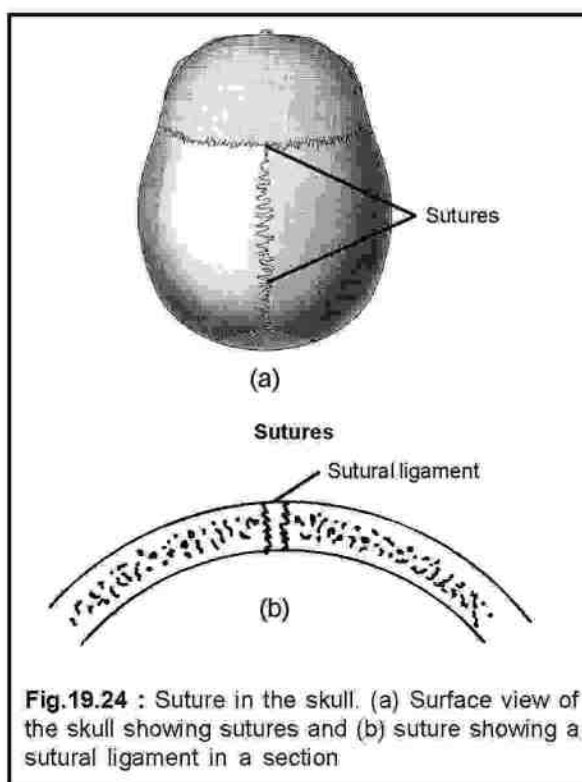

**Fig.19.24 :** Suture in the skull. (a) Surface view of the skull showing sutures and (b) suture showing a sutural ligament

(b) **Cartilaginous joints** : A limited degree of movement is allowed at this type of joint. This is of two types: (i) synchondroses and (ii) symphysis.

(i) **Synchondroses (singular; synchondrosis) (Fig. 19.27) :**

This type of joint occurs, where two ossification centres in a growing bone remain separated by a layer of cartilage. The cartilage keeps adding bony substance to both ends until it is completely ossified. (e.g.; a region between the shaft and head of long growing bones)

(ii) **Symphyses (Fig.19.28) :** Two separate bones are connected by a cartilage. (e.g.; pubic symphysis and intervertebral disc)

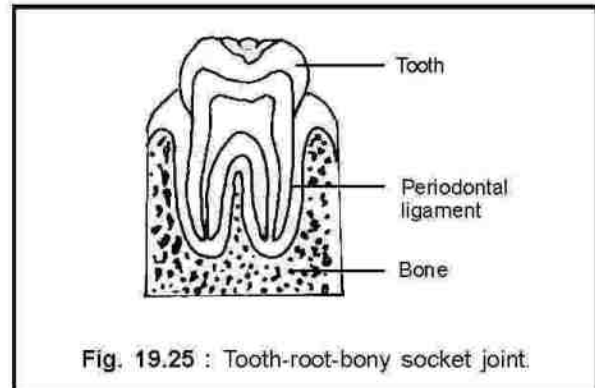

Fig. 19.25 : Tooth-root-bony socket joint.

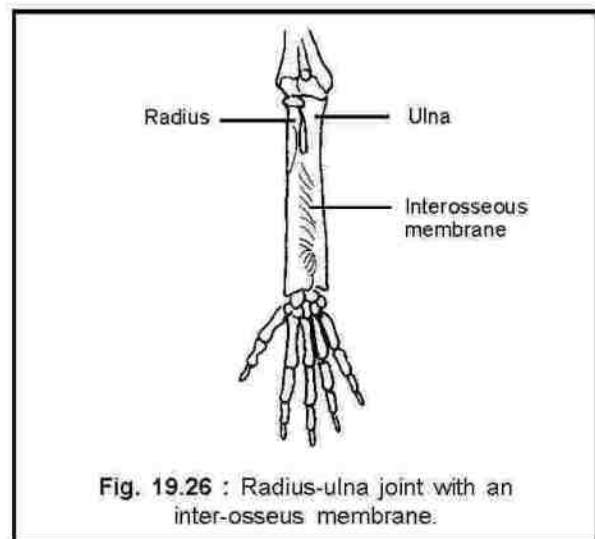

Fig. 19.26 : Radius-ulna joint with an inter-osseus membrane.

#### 19.4.4. Movements at joints :

The entire human body is flexible due to the presence of many joints in the endoskeletal frame. The arms and legs perform more flexible movements in space relative to other parts of the body.

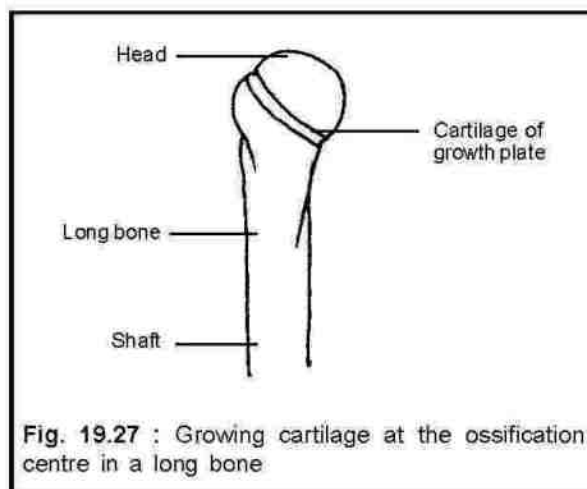

Fig. 19.27 : Growing cartilage at the ossification centre in a long bone

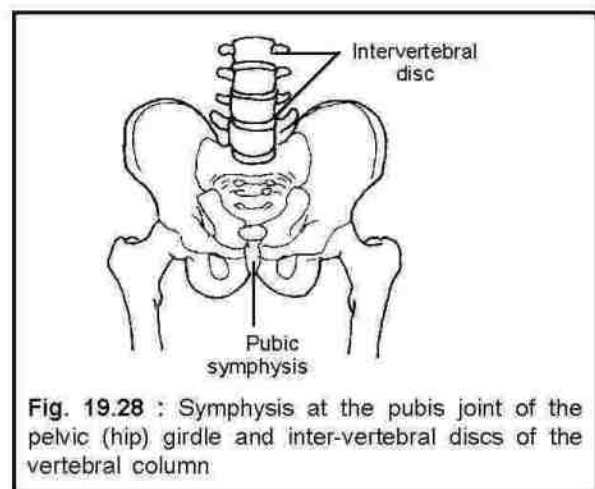
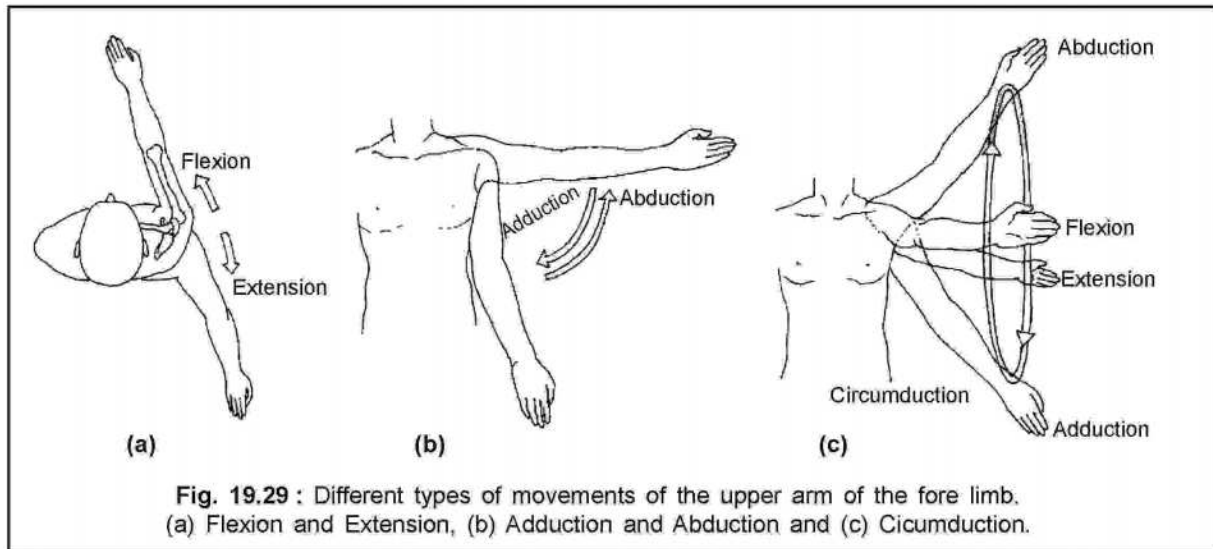

Fig. 19.28 : Symphysis at the pubis joint of the pelvic (hip) girdle and inter-vertebral discs of the vertebral column



#### 19.4.4.1. Movements at joints of the arm :

Unlike the leg, the hand is more mobile for positioning in space. The upper arm is joined to the shoulder at the gleno-humeral (shoulder) joint. The shoulder is suspended from the trunk by muscles. Sliding (protraction and retraction) and rotation of the scapula of the



pectoral girdle changes the position of the shoulder joint. Consequently, the upper arm moves around three axes. Movements of the upper arm at this joint are flexion, extension, abduction, adduction, medial and lateral rotation and circumduction. (Fig. 19.29)

The major movements at the elbow joint are flexion and extension of the fore arm [Fig. 19.30 (a)] The radius-ulna exhibits medial and lateral rotations [Fig. 19.30 (b). At the distal end, radius is flipped over the ulna by pronation and supination, acquiring palm-posterior and palm-anterior positions respectively [Fig. 19.30 (c)]

At the wrist joint, the hand is abducted, adducted, flexed and extended [Fig. 19.31 (a) & (b)]. Similarly, the fingers exhibit abduction, adduction, flexion and extension at the metacarpo-phalangeal joints (Fig. 19.32).

#### 19.4.4.2. Movements at joints of leg :

The major function of the leg is locomotion. It involves an integration of movements at all joints for an upright posture and displacement with time.

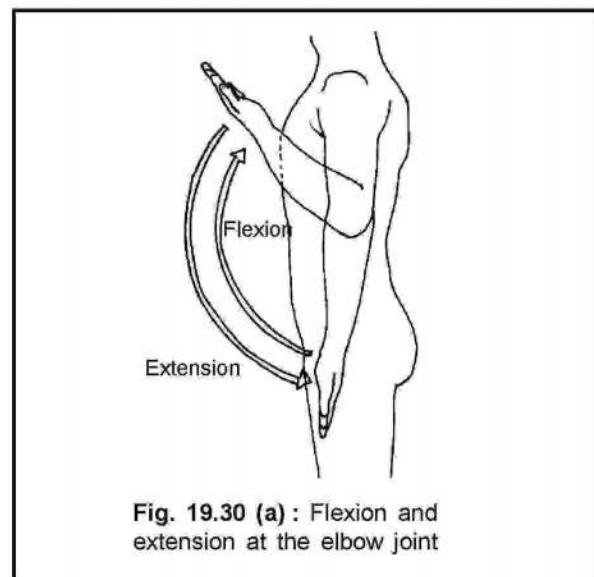

The movements at the hip joint are flexion, extension, abduction, adduction and medial and lateral rotation (Fig. 19.33 and 19.34)

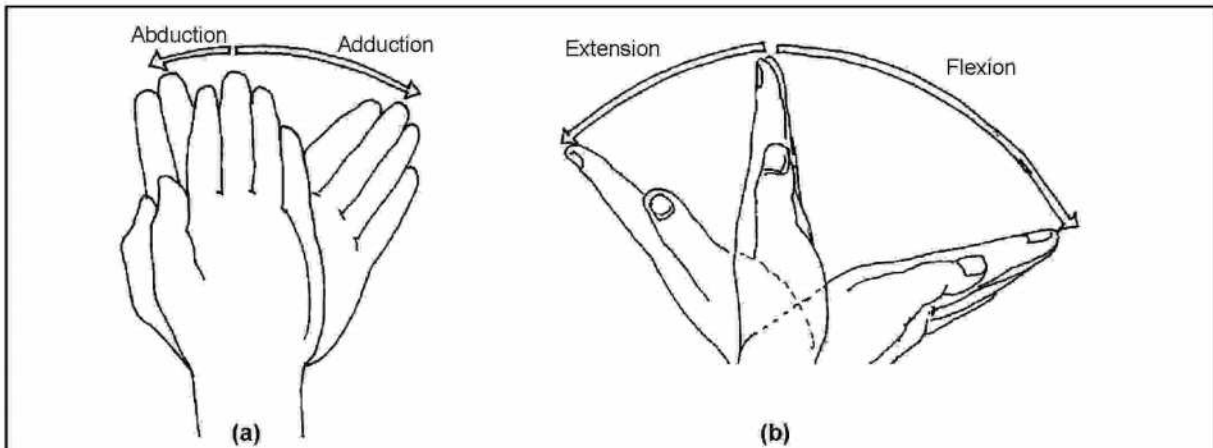
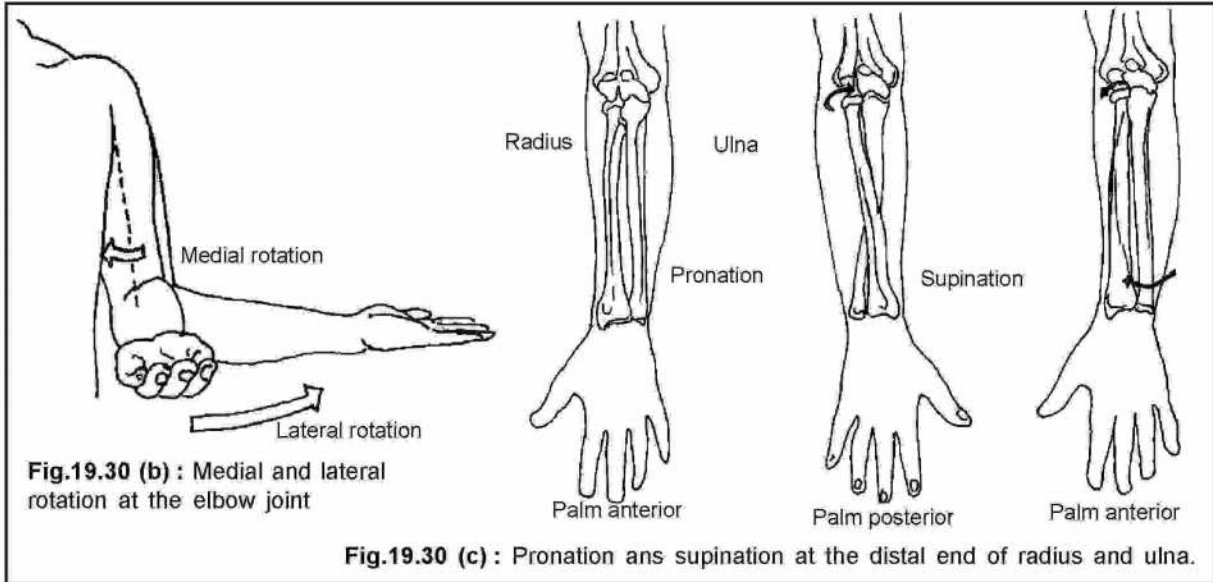

**Fig. 19.31 :** Movement of bones at the wrist joint. (a) Abduction and adduction and (b) Extension and flexion

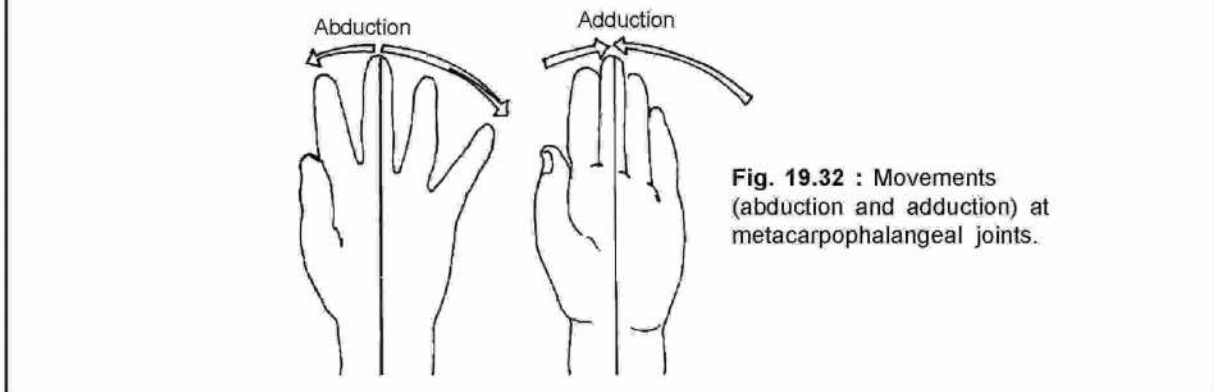

**Fig. 19.32 :** Movements (abduction and adduction) at metacarpophalangeal joints.

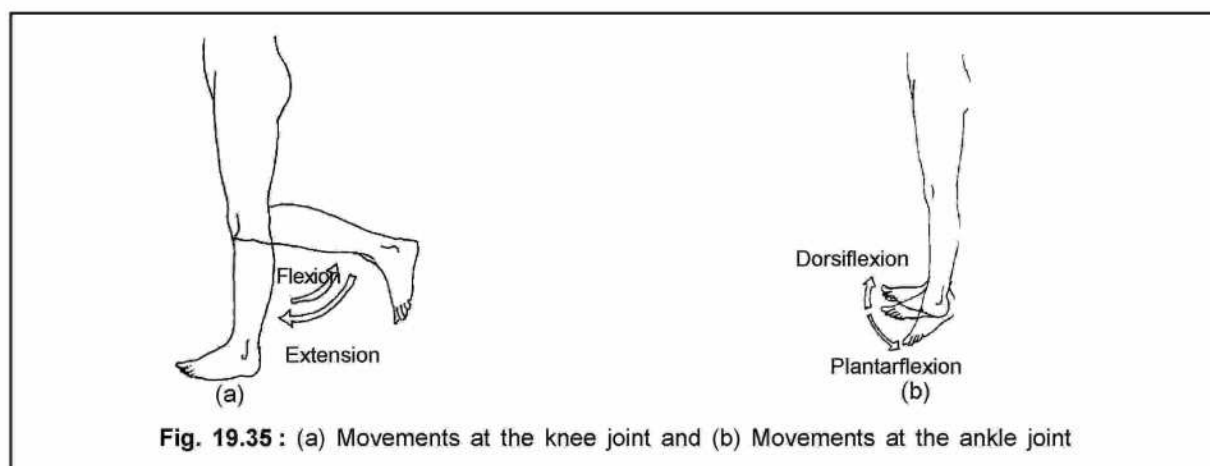
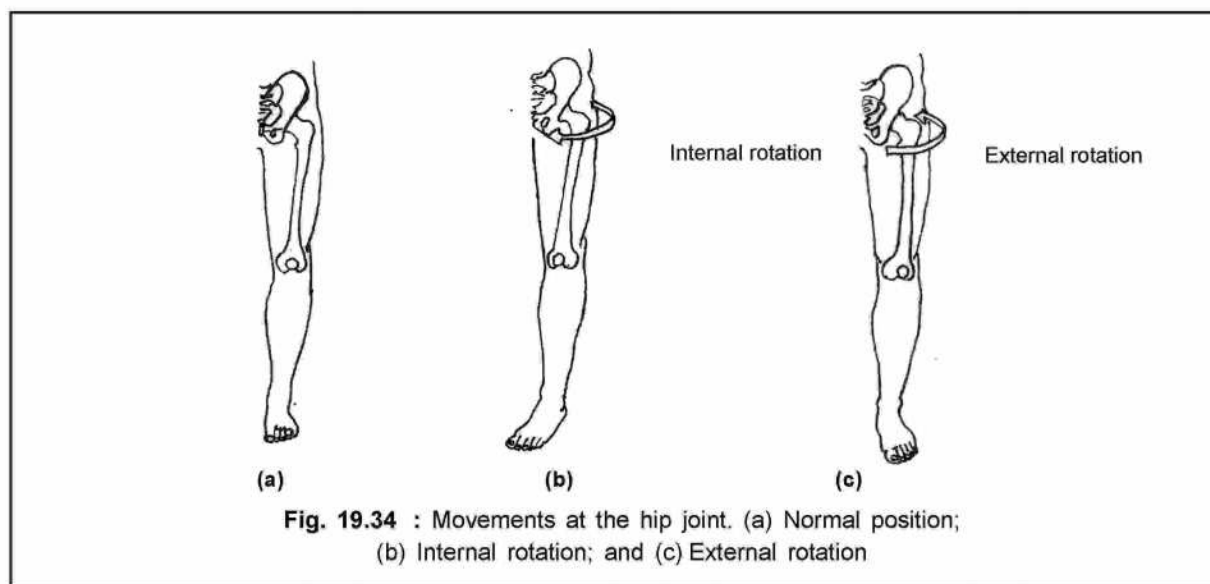
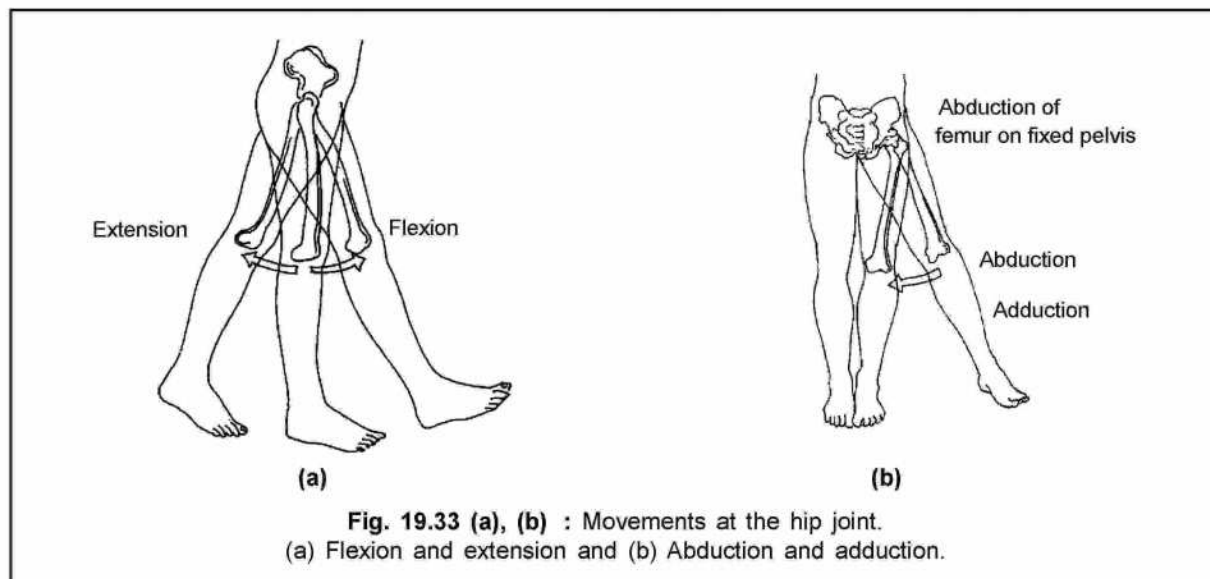

The movements at the knee joint are flexion and extension [Fig. 19.35 (a)]. Movements at the ankle joint are dorsiflexion (movement of the dorsal side of the foot towards the leg) and plantarflexion [Fig. 19.35 (b)]

## 19.5. DISORDERS OF MUSCULAR AND SKELETAL SYSTEMS :

### 19.5.1. Myasthenia gravis :

It is an autoimmune disorder, in which self antibodies are generated against acetylcholine receptors at the neuro-muscular junctions. The consequence is the blockage and destruction of these receptors. The motor nerve fibers fail to transmit the signal to the muscle (effector). This leads to severe muscle weakness.

### 19.5.2. Tetany :

When a muscle is stimulated rapidly and repeatedly, contraction occurs before it is relaxed. The individual contraction responses fuse into one continuous contraction. This response is known as tetanus. In a complete tetanus, there is no relaxation between periods of contraction and in incomplete tetanus, there are short periods of relaxation between stimuli.

### 19.5.3. Muscular dystrophy :

Muscular dystrophy refers to a disorganization of the skeletal muscle fibers. The most serious of all dystrophies is Duchenne Muscular Dystrophy (DMD). It is an X-linked disorder. Persons carrying this disorder die around the age of 30 years. A gene present on X chromosome encodes a protein dystrophin, which is a constituent protein of the cytoskeleton of the muscle fiber. When the gene undergoes a mutation, normal dystrophin protein fails to be synthesized. The consequence is that the cytoskeleton becomes abnormal and the muscle fiber becomes fragile. Another mild form of the dystrophy is Baker's Muscular Dystrophy. In this case, the dystrophin protein is present, however, its structure is altered.

### 19.5.4. Arthritis :

Arthritis is an inflammatory condition of the joints causing pain and swelling. It is the three types : rheumatoid arthritis, osteoarthritis and gout. The case of gout will be treated separately.

Rheumatoid arthritis is an autoimmune disorder, in which the immune system fails to recognize the self antigens. This pathological condition occurs at synovial joints due to nerve and chronic inflammation. There is a gradual destruction of cartilage and bony material at joints.

Osteoarthritis is a degenerative joint disease, also occurring at synovial joints. The bony and cartilaginous elements at this joint change in structure. Occasionally there are bony outgrowths and cysts at such joints, so that there is a limited movement at such joints. Movements at these joints generate severe and unbearable pain.

**19.5.5. Osteoporosis :**

This is the most common metabolic bone disorder in elderly people. It is characterized by the loss of minerals and organic matrix from bone, reducing bone mass and density. There is an increase in risk of bone fracture. It occurs in women between their 50s and 60s and in men in 70s. It is more prevalent in women than in men. Although the causes of osteoporosis are not well understood, it is believed that reduced levels of estrogen secretion at menopause may cause this condition. The withdrawal of estrogen causes increased formation of osteoclasts. There is an imbalance between bone formation and resorption. Therefore, teenage girls are advised to eat more calcium rich food such as milk and other dairy products so as to slow down the progression of osteoporosis.

**19.5.6. Gout :**

It is yet another form of arthritis. Gout is characterized by an elevated level of uric acid in the body fluid. This causes an excess deposition of insoluble crystals of sodium urate at the joints, especially of the big toe, causing painful inflammation. The most prevalent cause of gout is an improper excretion of uric acid. It may also result from a number of metabolic deficiencies. One well understood cause is the deficiency of an enzyme involved in purin metabolism. This leads to an excess production of uric acid, leading to a syndroms called Lesh-Nyhan syndrome.

---

**SAMPLE QUESTIONS****GROUP - A****(Objective-type Questions)****1. Choose the correct answer**

- (i) The total no. of bones in human body is  
(a) 106 (b) 206  
(c) 306 (d) 246
- (ii) The contraction of muscle of shortest duration is seen in  
(a) Jaw (b) Eye lid  
(c) Heart (d) Intestine
- (iii) What is the total number of ribs in human ?  
(a) 12 (b) 16  
(c) 20 (d) 24
- (iv) Which unstriated muscle is entirely involuntary  
(a) In the diaphragm (c) At the base of external ear  
(b) In the eyelid (d) At the pylorus
- (v) Total no. of muscles in human is  
(a) 639 (b) 936  
(c) 369 (d) 669
- (vi) Cori cycle operates within one of the following organs  
(a) Liver only (b) Liver and muscle  
(c) Muscle only (d) None of these
- (vii) One of the following muscles contains myoglobin, stores oxygen and rich in mitochondria  
(a) White muscle (b) Red muscle  
(c) Both (d) None
- (viii) How many vertebrae are present in man?  
(a) 33 (c) 31  
(b) 32 (d) 30
- (ix) Cervical vertebrae are present in  
(a) Thorax (b) Neck  
(c) Abdomen (d) Tail
- (x) Study of muscle is known as  
(a) Muscology (b) Myology  
(c) Arthrology (d) Mycology
- (xi) Knee joint is a  
(a) Ball and socket Joint (c) Hinge Joint  
(b) Pivot Joint (d) Bicondylar joint

- (xii) Study of joints is called  
(a) Osteology (b) Mycology  
(c) Arthrology (d) Chondrology
- (xiii) Joint between femur and pelvic girdle is called  
(a) Ball and socket Joint (c) Saddle Joint  
(b) Pivot Joint (d) Hinge Joint
- (xiv) Joint between the lower jaw and skull is called  
(a) Gliding (b) Hinge  
(c) Perfect (d) Gomphoses
- (xv) Which bone is present in pectoral girdle of all mammal  
(a) Scapula (b) Ilium  
(c) Coracoid (d) Pubis
- (xvi) If ossification occurs in a tendon, which bone is formed  
(a) Sesamoid bone (c) Membrane bone  
(b) Replacing bone (d) Dermal bone
- (xvii) Which of the muscles bends the fore arm upward  
(a) Biceps (c) Gastrocremius  
(b) Triceps (d) Gluteus maximus
- (xviii) Which bone is the longest in the body  
(a) Fibula (b) Femur  
(c) Tibia (d) Ulna
- (xix) Which bone of man is not used for protection and support in the body  
(a) Stapes (b) Atlas  
(c) Ribs (d) Scapula
- (xx) The joint between carpals and radius and ulna is called  
(a) Condylar Joint (c) Gliding Joint  
(b) Immovable Joint (d) Saddle Joint
- (xxi) Articulation of odontoid process of axis and atlas vertebrae is an example of  
(a) Gliding Joint (c) Pivot Joint  
(b) Ball & socket Joint (d) Hinge Joint
- (xxii) Articulation of metacarpal of thumb with its carpal is an example of  
(a) Saddle Joint (b) Hinge Joint  
(c) Pivot Joint (d) Gliding Joint
- (xxiii) Articular cavity the pectoral girdle is  
(a) Acetabulum (c) Neural canal  
(b) Glenoid cavity (d) Foramen of Monro
- (xxiv) Name of the joint at acetabulum  
(a) Hip Joint (c) Knee Joint  
(b) Shoulder Joint (d) Elbow Joint

- (xxv) Sutures present between various bones of the skull are  
(a) Cartilaginous Joint                      (c) Hinge Joint  
(b) Synovial Joint                              (d) Fibrous Joint
- (xxvi) Number of true ribs and floating ribs are  
(a) 6 & 3    (b) 0 & 2  
(c) 9 & 4    (d) 20 & 4
- (xxvii) Which joint occurs between humerus and radius and ulna  
(a) Pivot Joint                                  (c) Sliding Joint  
(b) Hinge Joint                                  (d) Ball & Socket Joint
- (xxviii) Functions of long bones in mammal is to provide  
(a) Support  
(b) Support and production of RBCs  
(c) Support and production of WBC  
(d) Support and production of RBCs and WBCs
- (xxix) Epiphyseal plate at the extremity of long bones help in  
(a) Elongation of bone  
(b) Bone moulding  
(c) Bone formation  
(d) Formation of Haversian canals
- (xxx) Muscle that bends one part over another is  
(a) Extensor                                      (b) Flexor  
(c) Adductor                                      (d) Abductor
- (xxxi) Malleus, incus and stapes occur in  
(a) Skull    (b) Middle ear  
(c) Pectoral girdle                              (d) Pelvic girdle

**2. Express the following statements in one word or more words, wherever necessary.**

- (i) What is the name of the contractile unit of a skeletal muscle fibre.
- (ii) What is myology ?
- (iii) Where do you see pivot joint ?
- (iv) Give an example of gomphosis.
- (v) What is the alternate name of breast bone ?
- (vi) In which part of the endo skeleton you come across sutures ?
- (vii) What do you call the bones of the wrist ?
- (viii) How many lumbar vertebrae are there in human ?
- (ix) What is a vertebrate limb having five digits known as ?
- (x) What is the alternate source of energy in a skeletal muscle ?



**3. Fill in the blanks with appropriate words :**

- (i) \_\_\_\_\_ muscle contracts during flexion of the elbow joint.
- (ii) Hip joint is an example of \_\_\_\_\_ joint.
- (iii) The centrum of mammalian vertebrae is of \_\_\_\_\_ type.
- (iv) Each 'I' band of the muscle fiber contains a dense line at the centre, known as \_\_\_\_\_.
- (v) \_\_\_\_\_ muscle relaxes the elbow joint.
- (vi) A muscle gets fatigued by an accumulation of \_\_\_\_\_.
- (vii) Myoglobin is found in \_\_\_\_\_
- (viii) Knee joint is a \_\_\_\_\_ type of joint.
- (ix) Contraction of \_\_\_\_\_ muscle helps in lifting heavy weight.
- (x) The stretch of a myofibril between two Z-lines is known as \_\_\_\_\_.
- (xi) The shoulder joint is classified as \_\_\_\_\_ joint.
- (xii) Stiffening of the body after death of a person is known as \_\_\_\_\_.
- (xiii) There are \_\_\_\_\_ number of vertebrae in the human vertebral column.
- (xiv) Total number of bones in the human skull are \_\_\_\_\_.
- (xv) Total number of metacarpals in the wrist of man is \_\_\_\_\_.
- (xvi) There are \_\_\_\_\_ cervical vertebrae in all mammals.

**GROUP - B****(Short Answer-type Questions)****1. Answer each within 50 words.**

- (i) What do you understand by a pentadactyl limb?
- (ii) Enlist the constituent parts of the appendicular skeletal system of human.
- (iii) Enlist the constituent parts of the axial skeletal system of human.
- (iv) What is the role of troponin in muscle contraction?
- (v) What is a synovial joint? Give two examples.
- (vi) What is a fibrous joint? Explain with an example.
- (vii) Differentiate between rheumatoid arthritis and osteoarthritis.
- (viii) What are myofilaments? How many types of myofilaments are present in a myofibril?
- (ix) Describe the role of troponin and tropomyosin in skeletal muscle contraction.
- (x) What is the role of phosphocreatine in the skeletal muscle contraction?
- (xi) What is sarcoplasmic reticulum? Where it is found and what is its function?
- (xii) What is muscle twitch?
- (xiii) What is an antagonistic muscle?
- (xiv) What is synovial fluid?
- (xv) What is the function of supinator muscle?

**2. Differentiate between two words in the following pairs words :**

- (i) Appendicular skeleton and Axial skeleton
- (ii) Synovial joint and Solid joint
- (iii) Actin and Myosin
- (iv) Rheumatoid asthritis and Osteoarthritis
- (v) Red muscle fibers and White muscle fibers
- (vi) Biceps and Triceps
- (vii) Skeletal muscle and Cardiac muscle
- (viii) Involuntary muscle and Voluntary muscle
- (ix) Striated muscle and Unstriated muscle.

**GROUP - C****(Long Answer-type Questions)**

1. Describe the sliding filament theory of skeletal muscle contraction.
2. Draw a neat labeled diagram of a sarcomere of skeletal muscle fiber (No description is necessary)



The nervous system along with the endocrine system serves as a communication system of the body. It regulates a majority of internal functions and controls the expression of human behaviour. Human behaviour not only includes such observed acts as smiling, crying moving body parts in response to external stimuli but also many acts, which can't be observed, such as thinking, emotion, learning, memory, etc. Therefore, the nervous system is the one, which coordinates amongst various parts of the body and makes it to function as an integrated whole. The body breaks apart without the proper functioning of this system.

The nervous system is studied from two counts: **structural** and **functional**. Structurally, it consists of two divisions, namely, (1) **central nervous system (CNS)** including the **brain** and the **spinal cord** and (2) **peripheral nervous system (PNS)**, constituted by the **cranial nerves** arising from the brain and **spinal nerves** arising from the spinal cord. The nerves of the PNS travel a long distance as that from the spinal cord to the finger tip and from the brain to the internal organs. Functionally, the system consists of two divisions: **somatic** and **visceral**. In the somatic division, there are innervations of structures like skin and skeletal muscle. It deals with receiving and responding to the information from the external environment. On the contrary, the visceral division innervates body's organ systems and other visceral elements such as smooth muscle and glands. It deals with detecting and responding to information from the internal environment. Hereunder, we are taking up with the structural components and in due course of the discussion, you will be acquainted with the functional aspects. Prior to it, we present a brief account of the cellular elements of the nervous system.

### 20.1. NEURAL TISSUE :

The fundamental units of the nervous system are the **nerve cells** or **neurons**. Structurally, a neuron is specialized in having an elongated shape with many processes arising from it. Functionally, it is also specialized in possessing an excitability property unlike a majority of cells. Hence, it has a property of conduction of impulses from one place of the body to the other. These cells help communicate from all parts of the body to the brain and vice versa. The neurons are generally aligned one after the other with specialized junctions known as **synapses**. That is, one neuron ends and the second begins with a junction, the **synapse**. The means of communication is by generating an **electric potential (impulse)** in one neuron and then transmitting it to the next across a synapse. At the synapse, the electrical impulse turns into a

chemical impulse and again it changes over to an electrical impulse in the next neuron. Thus, the communication by conduction is partly electrical and partly chemical.

### 20.1.1. Structure of a typical neuron :

Neurons vary considerably in shape, size and other features. However, most of them are built on a common plan. A neuron consists of a **cell body** also known as a **cyton** or **soma** or **perikaryon**. It gives off a variable number of processes called **neurites** [Fig. 20.1 (a)].

**20.1.1.1. Cell Body [Fig. 20.1. (b)] :** It contains a mass of cytoplasm surrounding a centrally situated nucleus with a plasma membrane as the limiting membrane. The cytoplasm contains cytoplasmic organelles typical to a cell. The presence of centrioles was debated in the past. However, electronmicroscopic study has revealed the presence of a pair of centrioles. The cytoplasm contains basophilic (stains with basic dyes) granular materials called **Nissl body** or **substance** or **granule**. Electronmicroscopic study has confirmed that Nissl body contains parallel stacks of rough endoplasmic reticulum. The dendrites also contain rough endoplasmic reticulum, while the axon doesn't. However, smooth endoplasmic reticulum is present in all parts of the neuron cytoplasm. Lysosomes are present only in the cell body. Many slender mitochondria are present in the cell body and dendrites. Mitochondria also occur in the axon cytoplasm but are more numerous in the axon terminals. The cytoplasm is traversed by a network of slender fibers called **neurofibrils**. These fibrils are the microfilaments consisting of microtubules.

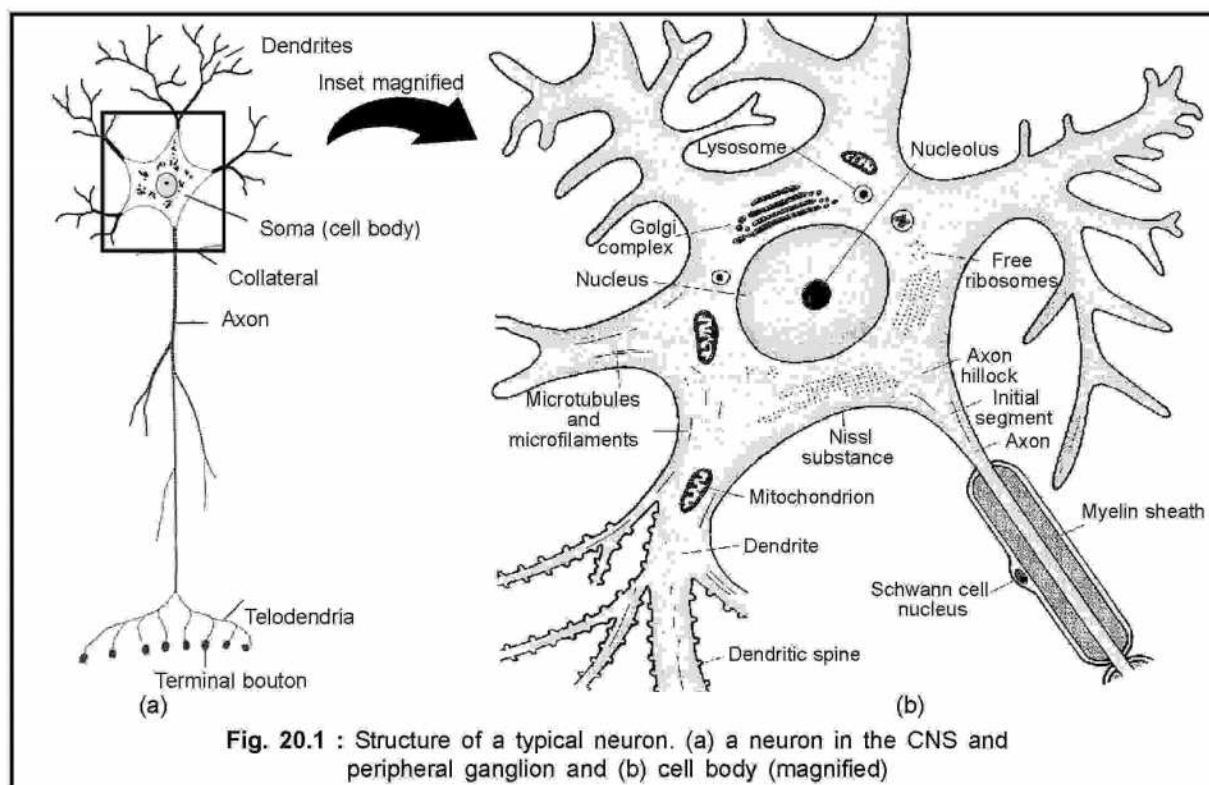

**Fig. 20.1 :** Structure of a typical neuron. (a) a neuron in the CNS and peripheral ganglion and (b) cell body (magnified)

**20.1.1.2. Neurites:** The neurites are of two types: **axon** and **dendrites** [Fig. 20.1 (a) and 20.2]

**(a) Axon:** The axon is the singular long process, which arises from the cell body and conducts the impulse away from it. It originates from a conical protrusion of the cell body known as **axon hillock**. An axon is of uniform diameter and is devoid of Nissl body. The axons, with the exception of those of the CNS, associate with nonconducting cells called **Schwann cells** (Fig. 20.2). These cells form and deposit an insulating lipid, known as **myelin** around these axons. **Myelin sheath** or **medullary sheath** forms an insulating sheath around many peripheral nerves and thus protects the adjoining tissues from developing a potential difference during conduction of nerve impulse (Fig. 20.3). A thin layer of Schwann cell cytoplasm persists on the outer side of myelin sheath forming a secondary layer called **neurilemma**. The myelin is deposited in a discontinuous manner around most peripheral nerves. This results in the formation of distinct **nodes** and **internodes** along the length of the axon. The myelin insulated part is the internode, while the myelin free part is the node called **node of Ranvier** (Fig. 20.2). Such myelin encapsulated nerve fibers are known as **myelinated** or **medullated nerve fibers**, while those without myelin sheaths are **unmyelinated** or **nonmedullated nerve fibers**. The axons lying in the CNS are provided with a similar type of sheath by **oligodendrocytes** [Fig. 20.2 (above the broken line)] .

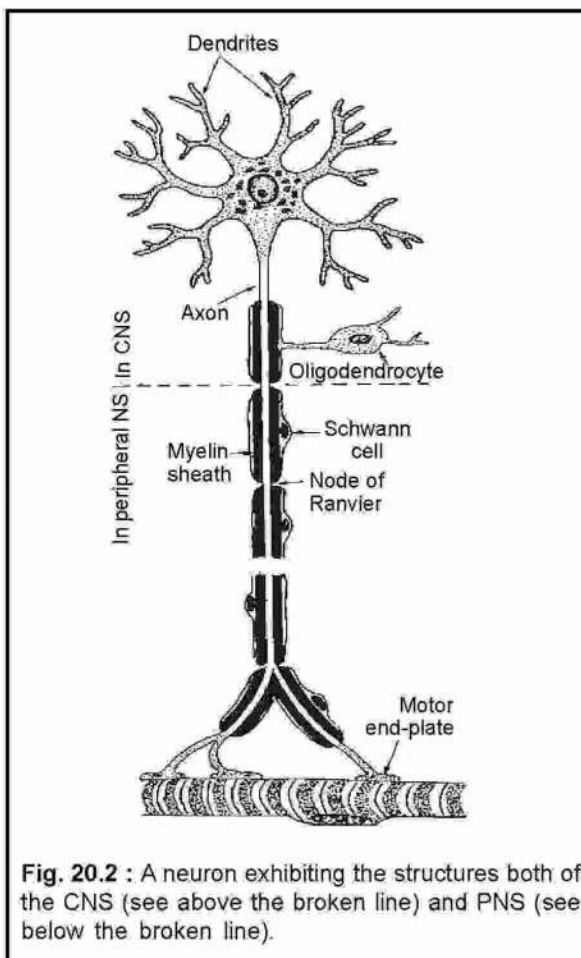

**Fig. 20.2 :** A neuron exhibiting the structures both of the CNS (see above the broken line) and PNS (see below the broken line).

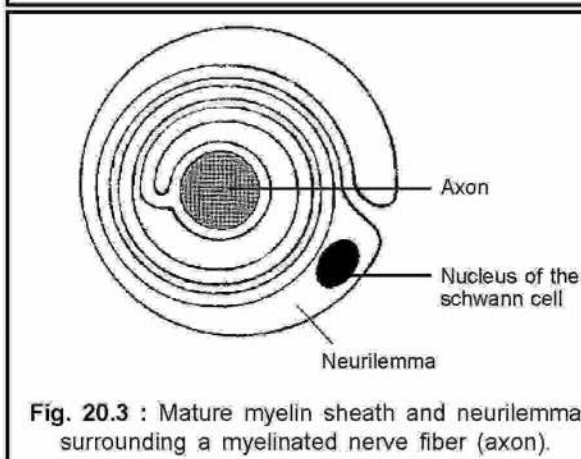

**Fig. 20.3 :** Mature myelin sheath and neurilemma surrounding a myelinated nerve fiber (axon).

- **Multiple Sclerosis**

It is a **chronic neurodegenerative disease** that destroys **myelin sheaths of neurons** in multiple areas of the CNS. The myelin sheaths harden and become defunct. The consequence is **loss of impulse conduction property**. It leads to a **progressive loss of functions of the CNS**. One of the causes of this disease is the **destruction of the oligodendrocytes and myelin sheaths by the self immune system**. **Inflammation occurs**, which then leads to **demyelination**.

The axon may give off variable number of branches. Branches, which arise near the cell body and are perpendicular to the axon are known as **collaterals** [Fig. 20.1 (a)]. At its termination, the axon breaks up into many finer branches called **telodendria** that may end in small swellings known as **terminal boutons**. An axon terminates in either of the two ways. In the CNS, its terminal part forms a junction (synapse) with the dendron of another neuron known as an **interneuron** or **integrator neuron**. Outside the CNS, an axon terminates in an **effector tissue** or organ. The axon terminals are responsible for releasing chemical messengers from the axon. Some neurons release their chemical messengers from a series of bulgings along the axon. These bulging have been termed as **varicosities**.

**(b) Dendrites:** The many nerve processes, which terminate near the cell body are known as dendrites. Dendrites are shorter in length and are more numerous containing Nissl body. Dendrites carry impulses towards the cell body.

#### Nonconducting supporting cells in the CNS

- **Neuroglia** are the nonconducting supporting cells of the CNS. In addition to a mechanical support, they provide a suitable environment for optimal functioning of neurons. These are of four types: **astrocytes**, **oligodendrocytes**, **microglia** and **ependymal cells**.
- **Astrocytes:** Nourish neurons
- **Oligodendrocytes:** Form myelin sheaths around axons in the CNS
- **Microglia:** Serve as phagocytes to clear the damaged and injured parts of the CNS.
- **Ependymal cells:** Epithelial cells lining the ventricles of the brain and central canal of the spinal cord. Their cilia help in the streaming movement of the cerebrospinal fluid. Also serve as neural stem cells from which new neurons and neuroglial cells may be formed.

#### Nonconducting supporting cells in the PNS

- The PNS contains two types of supporting cells: **Schwann cells** and **satellite cells** or **ganglionic gliocytes**.
- **Schwann cell:** Form myelin sheath around axons in the PNS.
- **Satellite cells** or **ganglionic gliocytes:** Support cell bodies of neurons in the ganglia of the PNS.

### 20.1.2. Classification of neurons:

Neurons are classified both from **structural** and **functional** standpoints.

**20.1.2.1. Structural classification (Fig. 20.4) :** Neurons are classed as **pseudounipolar**, **bipolar** and **multipolar** from structural view point.

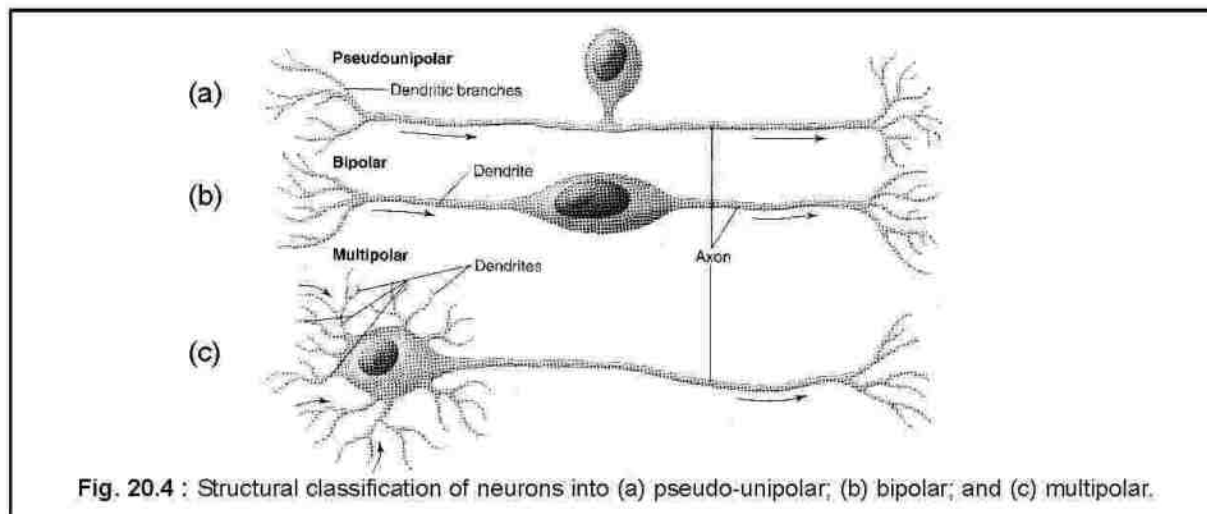

Fig. 20.4 : Structural classification of neurons into (a) pseudo-unipolar; (b) bipolar; and (c) multipolar.

(a) **Pseudo-unipolar neuron:** A short single process, the axon originates from the cell body and soon after its origin; it bifurcates into a longer peripheral and a shorter central process. The peripheral process ends in a receptor organ, while the shorter central process enters into the CNS, where it forms synapses with other neurons. **Somatic sensory and visceral sensory neurons** fall under this category.

(b) **Bipolar neuron:** A bipolar neuron has two processes, one each at two poles of the cell body. One process is the axon, while the other is a dendron. This type is found in the retina of the eye.

(c) **Multipolar neuron:** This neuron has several short processes at one pole, while a single long process at the opposite pole. The shorter processes are the dendrites, while the single long process is the axon. This is the most abundant type of neuron in the nervous system

**20.1.2.2. Functional classification (Fig. 20.5) :** Neurons are of three types, namely afferent (sensory), efferent (motor) and interneurons or association neurons or integrator neurons.

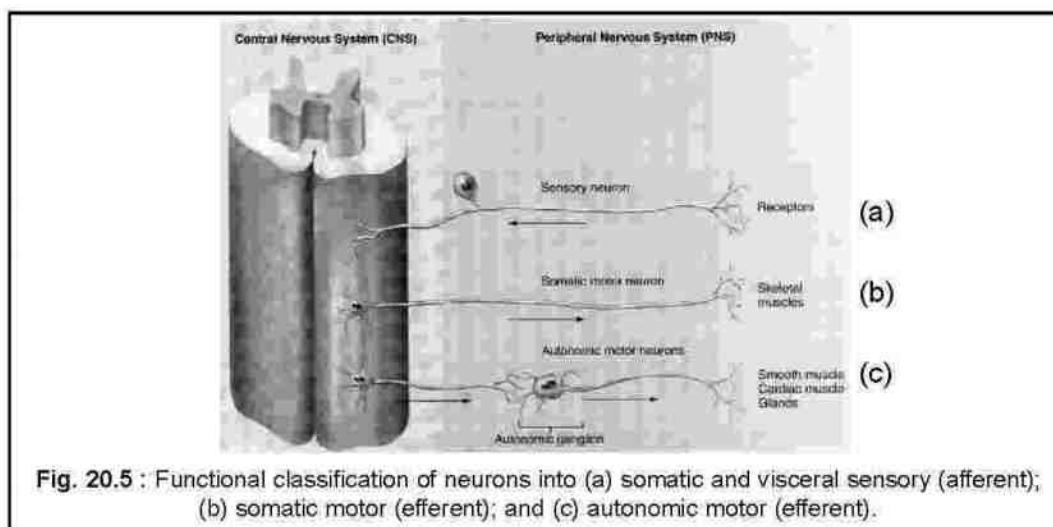

Fig. 20.5 : Functional classification of neurons into (a) somatic and visceral sensory (afferent); (b) somatic motor (efferent); and (c) autonomic motor (efferent).

(a) **Afferent neurons:** Afferent neurons are also known as **sensory neurons**. These conduct impulse from the tissues and organs (**sensory receptors**) to the CNS. These are pseudounipolar neurons having a single short process, which branches like a 'T' to form a pair of long processes. These processes are two branches of the axon. The relatively longer peripheral process ends in a receptor, while the relatively shorter central process enters the CNS to form synapse with other neurons. The cell body and the longer peripheral process lie outside the CNS.

(b) **Efferent neurons:** Efferent neurons are also known as **motor neurons**. These conduct impulse from the CNS to the **effector tissues** and organs i.e. muscle and glands. There are two types of efferent (motor) neurons: **somatic** and **autonomic**. The **somatic motor neurons** are responsible for both reflex and voluntary control of skeletal muscle. The cell bodies and dendrites of the somatic motor neurons lie in the CNS, while the axons extend into the voluntary effector tissue (skeletal muscle). The autonomic motor neurons innervate the involuntary effector tissues and organs i.e. smooth muscle, cardiac muscle and glands. The cell bodies of the autonomic motor neurons lie outside the CNS in the autonomic ganglia. There are two types of autonomic motor neurons: **sympathetic** and **parasympathetic**. The autonomic motor neurons with their control centres constitute the **autonomic nervous system (ANS)**.

(c) **Interneurons:** These are also known as **association** or **integrator neurons**. These connect the afferent and efferent neurons in the CNS. These neurons play an integrative role in the nervous system.

The axons of both afferent and efferent neurons outside the CNS form nerves. An approximate estimate is that for each afferent neuron entering the CNS, there are about 10 efferent neurons and 2,00,000 interneurons. Interneurons account for 99% of all neurons.

### 20.1.3. Synapse (Fig. 20.6) :

A nerve is a cylindrical conducting structure formed by a bundle of fibers or axons of a group of neurons travelling together to a destination. The neurons are joined end to end or terminate in target tissues or organs forming specialized junctions called **synapses**. Alternately a synapse is a functional junction between a neuron and a second cell. In the CNS, this second cell is always a neuron, while in the PNS, it may either be a neuron or an effector cell within a muscle or gland. When the junction is with an effector cell, it is known as a **myoneural** or **neuromuscular junction**. In a neuron-neuron synapse, the preceding neuron is known as **pre-synaptic**, while the succeeding as **post-synaptic**.

Synapses are of two types: **electrical** and **chemical**. In an electrical synapse, the action potential is conducted from the pre-synaptic membrane to the postsynaptic membrane. The plasma membrane of the pre- and post-synaptic neurons are joined by gap junctions at the synapse. Electrical synapses are rare in mammalian nervous systems. In a chemical synapse, the plasma membranes of the pre and post-synaptic neurons are separated by a gap known as a **synaptic cleft** at the synapse. The terminal part of the pre-synaptic neuron has endings called terminal boutons. These endings store a chemical substance known as **neurotransmitter**



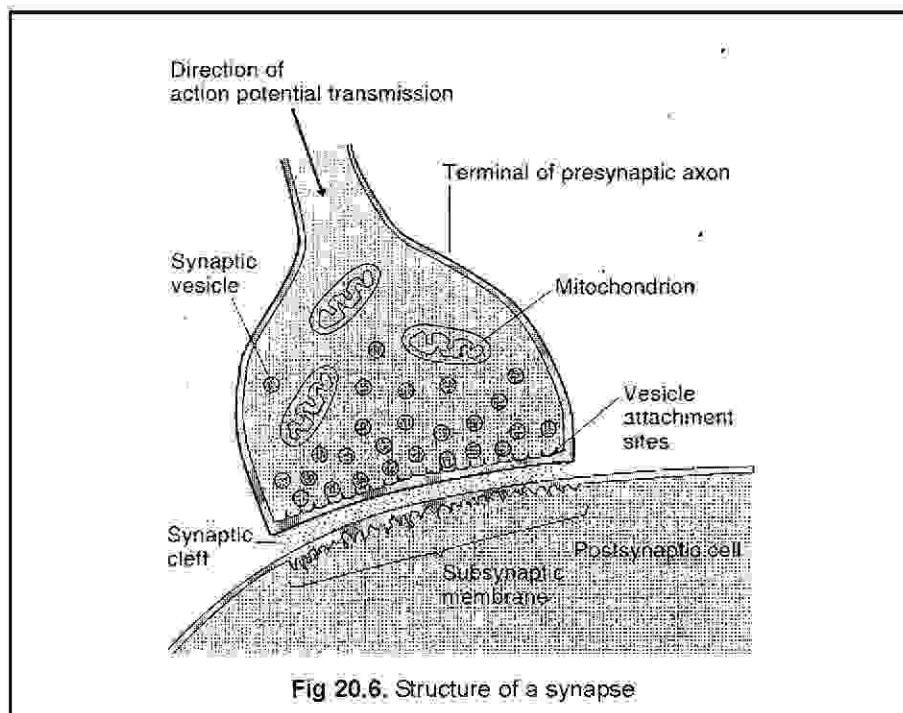

in **synaptic vesicles**. On depolarization of the presynaptic neuron membrane at the synapse, the synaptic vesicles fuse with membrane by exocytosis and thus release the neurotransmitter into the synaptic cleft. There are neurotransmitter specific receptors on the postsynaptic neuron membrane. The neurotransmitter molecules bind to their specific receptors and bring about a depolarization of the membrane which propagates in a forward direction.

## 20.2. THE SYSTEM :

The nervous system, as discussed above, is studied under two heads from structural standpoint: (1) **Central Nervous System (CNS)** consisting of the brain and the spinal cord and (2) **Peripheral Nervous System (PNS)** consisting of the nerves arising from the brain (cranial nerves) and spinal cord (spinal nerves), which innervate all points of the body.

- A group of nerve fibers in the CNS travelling together constitutes a **pathway** or **tract**. When a tract connects the right and left halves, it is a **commissure**. A group of fibers travelling together to the same general destination of the PNS constitutes a **nerve**.
- Groups of cell bodies of neurons in the CNS constitute **nuclei (singular: nucleus)**  
Groups of cell bodies in the PNS constitute **ganglia (singular: ganglion)**.

### 20.2.1. Central Nervous System (CNS) :

The CNS consists of the brain followed by a spinal cord. Since the brain and spinal cord are made by delicate nervous tissue, there are several degrees of protection to these structures. This system receives inputs from the sensory neurons and directs the activity of the motor neurons innervating muscles and glands. It maintains a state of equilibrium in the internal

environment and guarantees the continued existence of the individual in a changing external environment.

**20.2.1.1. Protective Layers of the CNS (Fig. 20.7) :** The brain is lodged in a **brain box** or **cranium** formed by several skull bones. Similarly, the spinal cord is present in the neural canal of the vertebral column. Besides the bones, both constituent parts of the CNS are surrounded by three concentric connective tissue layers known as **meninges** (**singular: meninx**). The outermost layer is the **dura mater** consisting of dense fibrous connective tissue. It forms an internal lining of the cranium as well as the neural canal. Inner to the dura mater, there is a more delicate connective tissue layer known as **arachnoid mater**. Inner to the arachnoid mater, there is a delicate connective tissue layer known as **pia mater**. This layer contains numerous blood vessels and directly adheres to the surface of the brain and spinal cord. There is a sub-arachnoid space between the arachnoid mater and pia mater. Fine and delicate collagen and elastic fibers attach the arachnoid mater to the pia mater forming web like **trabeculae**. The sub-arachnoid space is filled with a colourless fluid known as **cerebrospinal fluid (CSF)**, which acts as a cushion. The ventricles of the brain and the central canal of the spinal cord are also filled with CSF. Following its circulation, it is absorbed and drained into the venous blood by **arachnoid villi**. Fresh CSF is secreted into the space by the **choroid plexuses**.

- **Meningitis:**

**Meningitis is an infection and inflammation of the arachnoid mater and pia mater (leptomeninges) by some bacteria and viruses. Meningococcal bacteria are noteworthy in such an infection. Overwhelming inflammation may lead to cerebral irritation to an extent that may cause sepsis, coma and ultimately death.**

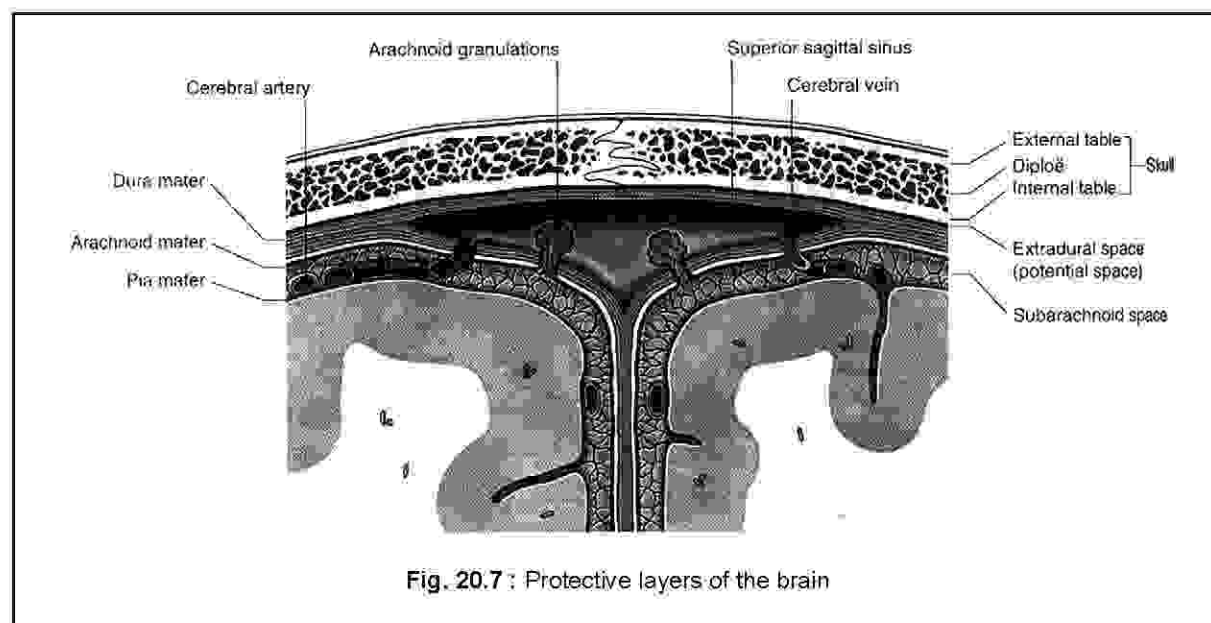

Fig. 20.7 : Protective layers of the brain

- **Hydrocephalus:**

It is a condition, in which there is a dilation of the ventricles of the brain due to an obstruction in the flow of CSF or overproduction of CSF or failure of its reabsorption. The CSF is secreted by the choroid plexuses. It circulates and reaches the fourth ventricle and passes into the subarachnoid space through foramina. It is then absorbed into the dural venous sinus through the arachnoid granulations. However, sometimes there is a failure of its reabsorption. It is the main cause of hydrocephalus in adults. Another cause is congenital obstruction of the aqueduct of Sylvius, where the CSF fails to pass from the third to the fourth ventricle leading to its failure of reabsorption and hence results in its accumulation and then to hydrocephalus.

**20.2.1.2. Brain :** During its development, the human brain has three major divisions: forebrain (prosencephalon), mid brain (mesencephalon) and hindbrain (rhombencephalon) (Fig. 20.8). The forebrain has two divisions, namely telencephalon, formed by a pair of cerebral hemispheres and a diencephalon. The cerebral hemispheres together constitute the cerebrum. The midbrain is constituted by corpora quadrigemina. The hind brain consists of two divisions such as metencephalon and myelencephalon. The metencephalon is constituted by pons and cerebellum, while the myelencephalon consists of medulla oblongata. Mid brain, pons and medulla oblongata form the brain stem. The adult brain contains an estimated 100 billion ( $10^{11}$ ) neurons, weighs about 1.5 Kg and receives about 20% of the body's total blood supply:

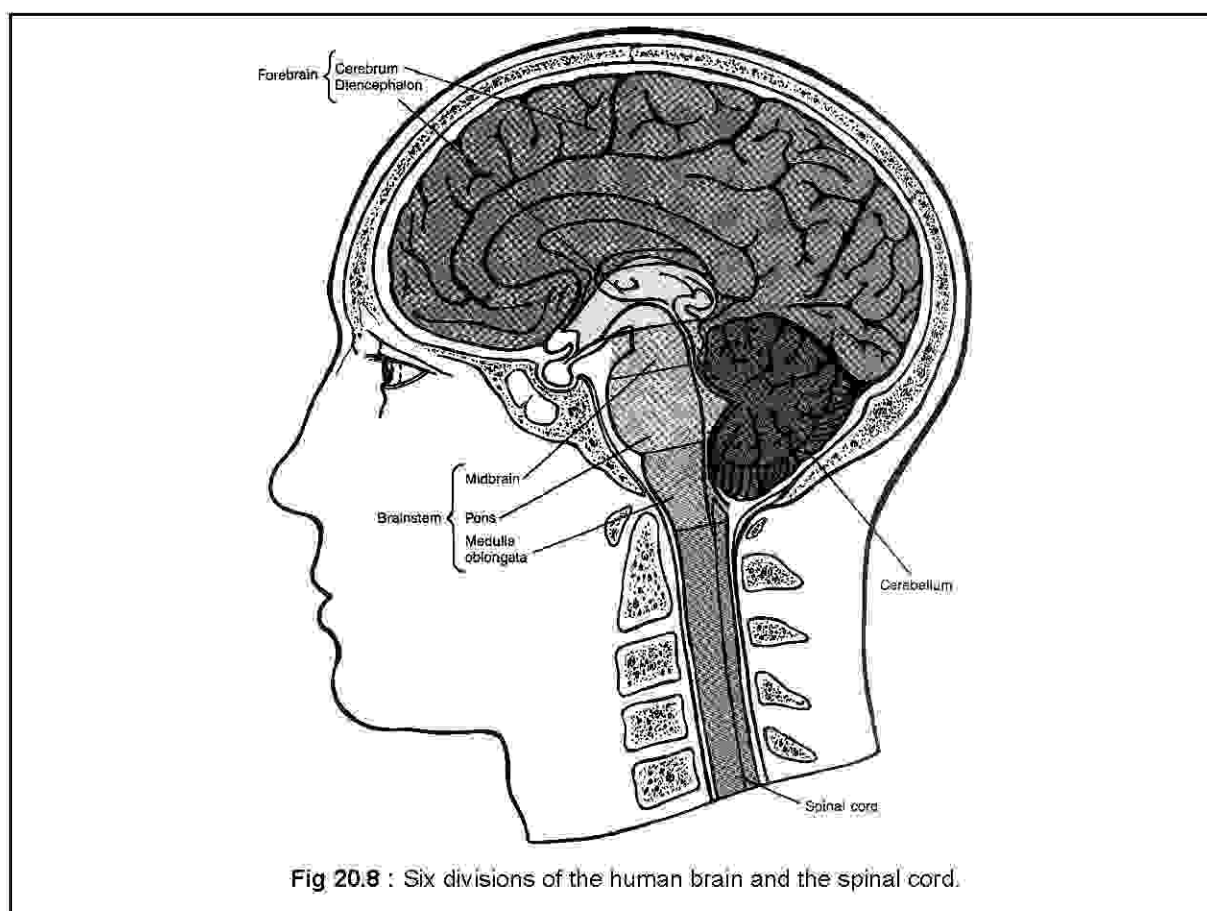

Fig 20.8 : Six divisions of the human brain and the spinal cord.

(a) **Forebrain (Prosencephalon):** The forebrain is divided into two regions: telencephalon constituted by two cerebral hemispheres (cerebrum) and diencephalon.

(i) **Cerebrum (Telencephalon):** The cerebrum consists of the right and left cerebral hemispheres, connected internally by a large tract of fibers called **corpus callosum**. The surface of the cerebrum is convoluted by the presence of several projections and depressions, known as **gyri (singular: gyrus)** and **sulci (singular: sulcus)**, respectively. Major sulci, which are deep depressions, divide each cerebral hemisphere into five lobes, namely **frontal, parietal, temporal, occipital** and **insula (Fig. 20.9)**. All lobes except insula are visible from the surface. Insula is present internally and covered by parts of frontal, parietal and temporal lobes. The cerebrum consists of an outer **cerebral cortex** consisting of 2 – 4 mm of **grey matter** with an underlying **white matter** and **subcortical nuclei**. The subcortical nuclei are parts of the grey matter present within the underlying white matter of the cerebral cortex. Predominant among the subcortical nuclei, are the **basal nuclei** or **ganglia**, which regulate voluntary movement and posture and other complex aspects of behavior. Again the most important of the basal nuclei is the **corpus striatum**, consisting of several nuclei, such as **caudate** and **lentiform nuclei**. Lentiform nucleus is constituted by **putamen** and **globus pallidus nuclei**. The degeneration in the caudate nucleus causes a dominant neuro-degenerative disorder, **Huntington's Chorea** or **disease**, characterised by rapid and uncontrolled jerky movements. The basal nuclei are involved in the control of voluntary movements.

The grey matter contains cell bodies of neurons and the dendrites while the white matter contains myelinated nerve fibers. Nerve fibers from various places, particularly from the thalamus and brain stem enter the cortex. Some of these convey about changes in the external environment, while others are involved in cortical excitability and arousal.

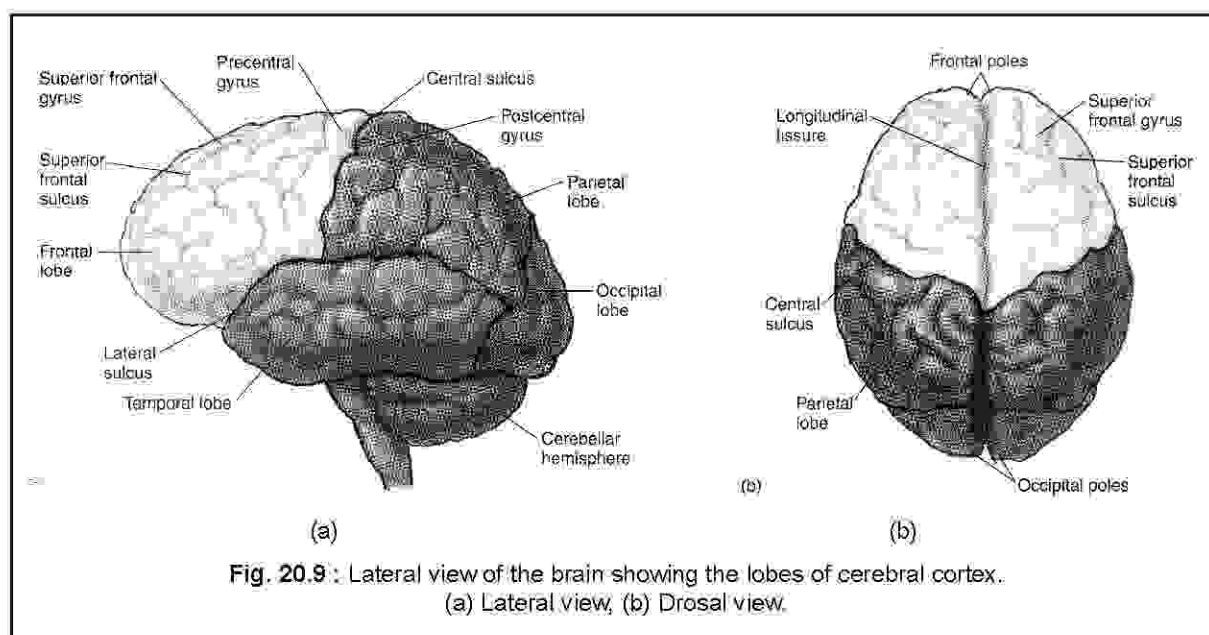
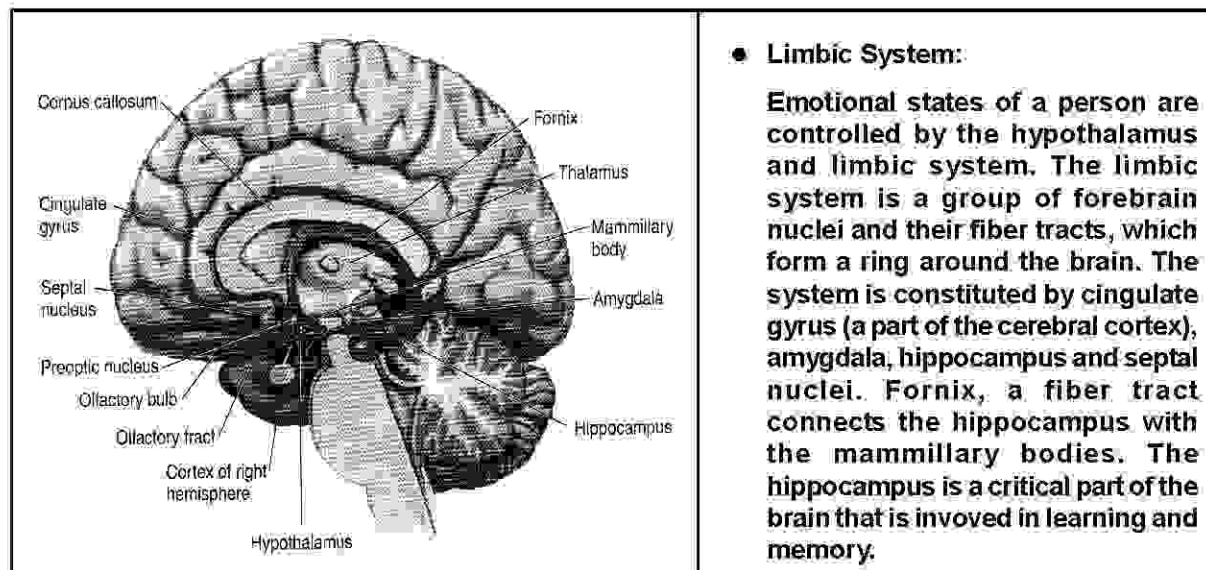

Fig. 20.9 : Lateral view of the brain showing the lobes of cerebral cortex.  
(a) Lateral view, (b) Dorsal view.



There are two forwardly directed **olfactory tracts** on the ventral side of the cerebrum, each ending in an **olfactory bulb**.

(ii) **Diencephalon:** It is a part of the fore brain consisting of **epithalamus, thalamus and hypothalamus**. The epithalamus is the dorsal part or roof of diencephalon containing a **choroid plexus** and the **pineal gland** or **epiphysis**. The choroid plexus secretes **CSF**, while the pineal secretes a hormone called **melatonin**. Melatonin plays a role in the endocrine control of reproduction.

The **thalamus** constitutes  $4/5^{\text{th}}$  part of the diencephalon and forms most of the wall of the third ventricle. It consists of paired patches of grey matter positioned below the respective lateral ventricle. It acts as a relay centre through which all sensory information inputs from all parts of the CNS except smell pass to the cerebrum. It is also responsible for relaying neural information outputs. The thalamus also brings about a state of alertness and causes arousal from sleep in response to an appropriate sensory stimulus.

The floor of diencephalon specializes as the **hypothalamus**. Although it is small, it regulates important functions like hunger and thirst. It also regulates sleep, wakefulness, sexual arousal and performance and such emotional behaviours like anger, fear, pain and pleasure. In its regulation of emotion, it works together with the limbic system. Hypothalamus acts as body's **thermostat** i.e. it regulates body temperature. The anterior hypothalamus contains bilateral **suprachiasmatic nuclei**, which are believed to regulate body's **circadian** or **daily rhythms**. The hypothalamus evaginates downward as a stalk known as the **infundibulum**. The tip of the infundibulum specializes as **posterior pituitary** or **neurohypophysis**. An **anterior pituitary** or **adenohypophysis** is associated with the posterior pituitary. Both constitute the **pituitary gland** or **hypophysis**. It is an important endocrine gland that regulates many target endocrine glands and other vital body functions.

- **The Brain Stem :**

The brain stem literally means stalk of the brain. It is constituted by mid brain, pons and medulla oblongata. It acts as a relay centre for sensory and motor pathways. A mass of loosely arranged cell bodies and axons, known as reticular formation run through the brain stem. The reticular formation establishes a communication network between the spinal cord and cerebrum. Information between the brain stem and cerebellum is established by three large bundles of nerve fibers known as cerebellar peduncles. Thus, it receives and integrates the information inputs from all parts of the CNS and dispatches instruction outputs.

- **Blood Brain Barrier :**

Unlike in most other organs, the brain capillaries do not have pores for free exchange of materials between the blood and extracellular fluid of the neural tissue. The endothelial cells are present in close adherence to each other with tight junctions. The endothelial cells with their tight junctions stand as a barrier, known as blood brain barrier. The barrier prevents free exchange between the two environments.

The barrier presents difficulty in chemotherapy and treating patients with DOPA, suffering from Parkinson's disease, since DOPA cannot cross the barrier. Such patients are administered with Levo-DOPA (L-DOPA), a precursor of DOPA. This precursor can cross the barrier into the neural tissue. Since all antibiotics cannot cross this barrier, antibiotics only that can cross the barrier are used in treating patients with meningitis.

(b) **Midbrain (Mesencephalon) :** The midbrain or mesencephalon is situated between the diencephalon and pons. It consists of four rounded elevations on its dorsal surface. These elevations constitute corpora quadrigemina. The two upper elevations are known as superior colliculi, which are involved in visual reflexes. The lower two, the inferior colliculi are relay centres for auditory information. The midbrain also contains the cerebral peduncles, red nucleus and substantia nigra.

- **Cerebral Stroke:**

A cerebral stroke is a cardiovascular accident, in which there is an interruption in the normal blood supply to the brain. It results in sub-normal or no functioning of the brain depending on the degree of stroke. It is of two types: ischemic and hemorrhagic. In ischemic type, the normal blood flow is prohibited by the formation of an atherosclerotic plaque in the carotid artery, which supplies the brain, while hemorrhagic stroke is caused by the rupture of blood capillaries due to hypertension or an accident. The risk factors for stroke are those of cardiovascular diseases such as diabetes mellitus and hypertension and smoking. Stroke is a neurological emergency. It requires an early diagnosis to decide on the course of action of a treatment.

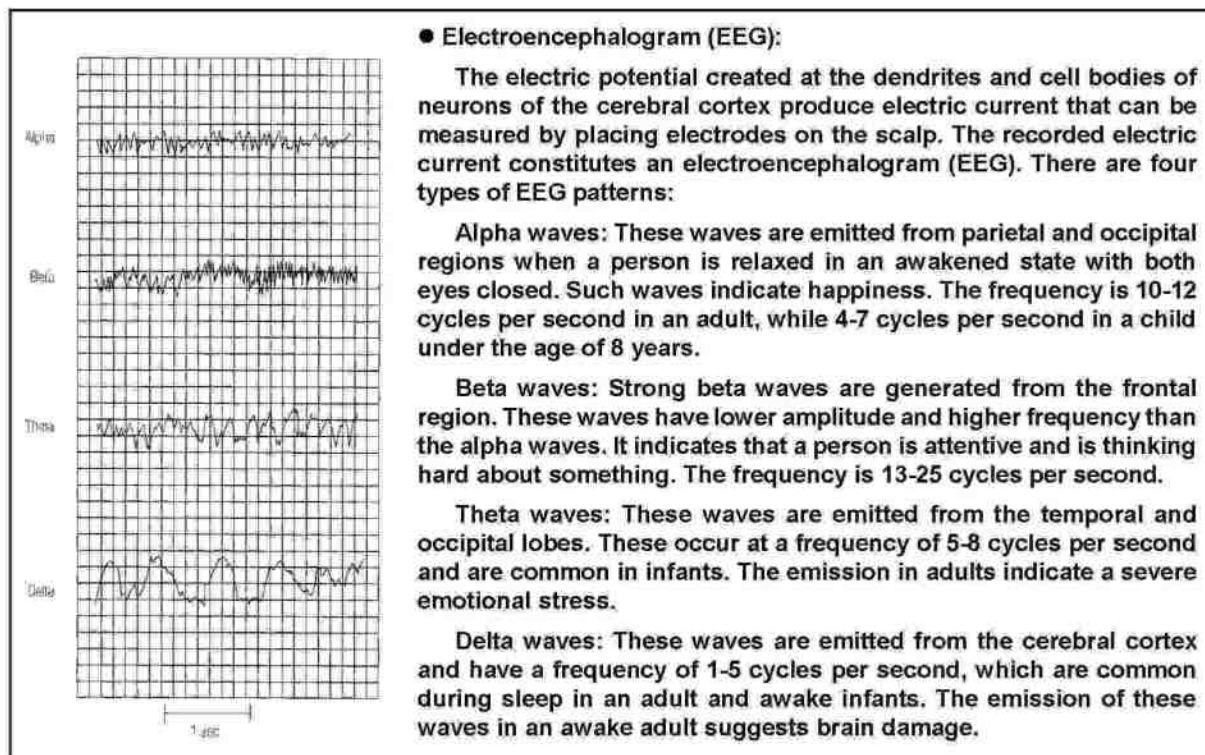

**(c) Hindbrain (Rhombencephalon) :** The hindbrain or rhombencephalon consists of two divisions: metencephalon and myelencephalon. The metencephalon is constituted by pons and cerebellum, while myelencephalon consists of medulla oblongata.

**(i) Pons (Metencephalon) :** It is a bulged part of the brain present on the lower side between the midbrain and medulla. It has both surface fibers and deeper fibers. The surface fibers connect the cerebellum, while deeper fibers, both sensory and motor, connect the midbrain with the medulla. It has several nuclei associated with trigeminal (V), abducens (VI), facial (VII), and vestibulo-cochlear (VIII) cranial nerves. Many other nuclei are associated with such regions of the medulla regulating breathing. These nuclei are the respiratory control centres in the pons.

**(ii) Cerebellum (Metencephalon) :** Next to the cerebrum, cerebellum is the complex regulatory centre of the brain. **It is also the second largest part of the brain, the first being the cerebrum.** It contains around 100 billion neurons. It is made up of three lobes, namely an **upper vermis** and two **lateral cerebellar hemispheres**. The cerebellum has an outer convoluted layer known as the **cerebellar cortex**. It consists of outer grey matter and an underlying white matter. Fibers from the cerebellum pass through the red nucleus of the thalamus to the cerebral cortex. Other tracts connect the cerebellum with the pons, medulla oblongata and spinal cord. The pair of fiber tracts, which connects the cerebellum with the brain stem is known as **cerebellar peduncles**. It receives several inputs from the receptor of joints, tendons and skeletal muscle. Working together with the basal nuclei and motor areas of the cerebral cortex, it coordinates

movements. Damage to the cerebellum produces **ataxia**, i.e. lack of coordination in speed and direction of movement. The speech is also affected like those of intoxicated persons.

- **Parkinson's Disease:**

It is a neurodegenerative disease, next to Alzheimers disease in frequency. There is a degeneration of dopaminergic neurons in the substantia nigra of the midbrain. These neurons send fibers to the corpus striatum of the basal nucleus (a large mass of subcortical neuronal cell bodies). These cell bodies initiate skeletal muscle movement. Their degeneration expresses symptoms, such as muscle tremors and rigidity, difficulty in initiating movements and speech and other severe motor problems. The patients are often treated with L-DOPA and monoamine oxidase inhibitors in an attempt to increase the dopaminergic transmission.

- **Alzheimer's Disease:**

It is the most frequently occurring neurodegenerative disease in the human population. It is associated with a progressive loss of memory (senile dementia) and mental deterioration. Lesions develop in the brain due to the deposition of dense extracellular insoluble proteins called amyloid beta proteins. Twisted fibrils called neurofibrillar tangles are formed within the decaying neurons. It is also associated with the degeneration of cholinergic neurons, which terminate in the hippocampus and cerebral cortex. The patients are currently treated with cholinesterase inhibitors in an attempt to increase cholinergic transmission in the brain. Another combination of treatment in practice is by vitamin E and other antioxidants, which would reduce oxidative stress.

(iii) **Medulla Oblongata (Myelencephalon)** : Simply known as medulla, it is a part of the brain between the anteriorly situated pons and spinal cord behind. All ascending and descending fiber tracts that communicate between spinal cord and brain pass through it. Many such fiber tracts of the left side cross over to the right and vice versa through elevated triangular structures called pyramids. The left side of the brain receives sensory information from the right side of the body, while the right from the left. Similarly, the right side of the brain controls motor activities of the left side of the body and vice versa. Cranial nerves VIII, IX, X, XI and XII arise from the medulla. The medulla contains groups of neurons implicated in the **regulation of breathing and cardiovascular functions**. The respiratory centre of the medulla acts in close cooperation with those present in the pons.

(d) **Ventricles of the brain (Fig. 20.10)** : The brain is a hollow structure, each segment of it having a cavity known as a ventricle. All the ventricles are continuous with each other. The ventricle continues into the spinal cord as a **central canal**. The ventricles of the brain and the central canal of the spinal cord are filled with circulating cerebrospinal fluid. The ventricles are as follows:



**Lateral ventricles (Paracoels):** Each cerebral hemisphere has a cavity inside it, known as **lateral ventricle**. There are two lateral ventricles numbered as first and second ventricles. The two lateral ventricles are connected with each other by an **interventricular foramen** known as the **foramen of Monro**.

**Third ventricle (Mesocoel):** It is the ventricle of the diencephalon. The lateral ventricles communicate with third ventricle through the foramen of Monro.

**Fourth ventricle (Metacoel):** It is the ventricle of pons, medulla and cerebellum. It is present dorsal to the pons and medulla and ventral to the cerebellum. The ventricular communication between the third ventricle and fourth ventricle is known as **cerebral aqueduct** or **aqueduct of Sylvius** or **iter**.

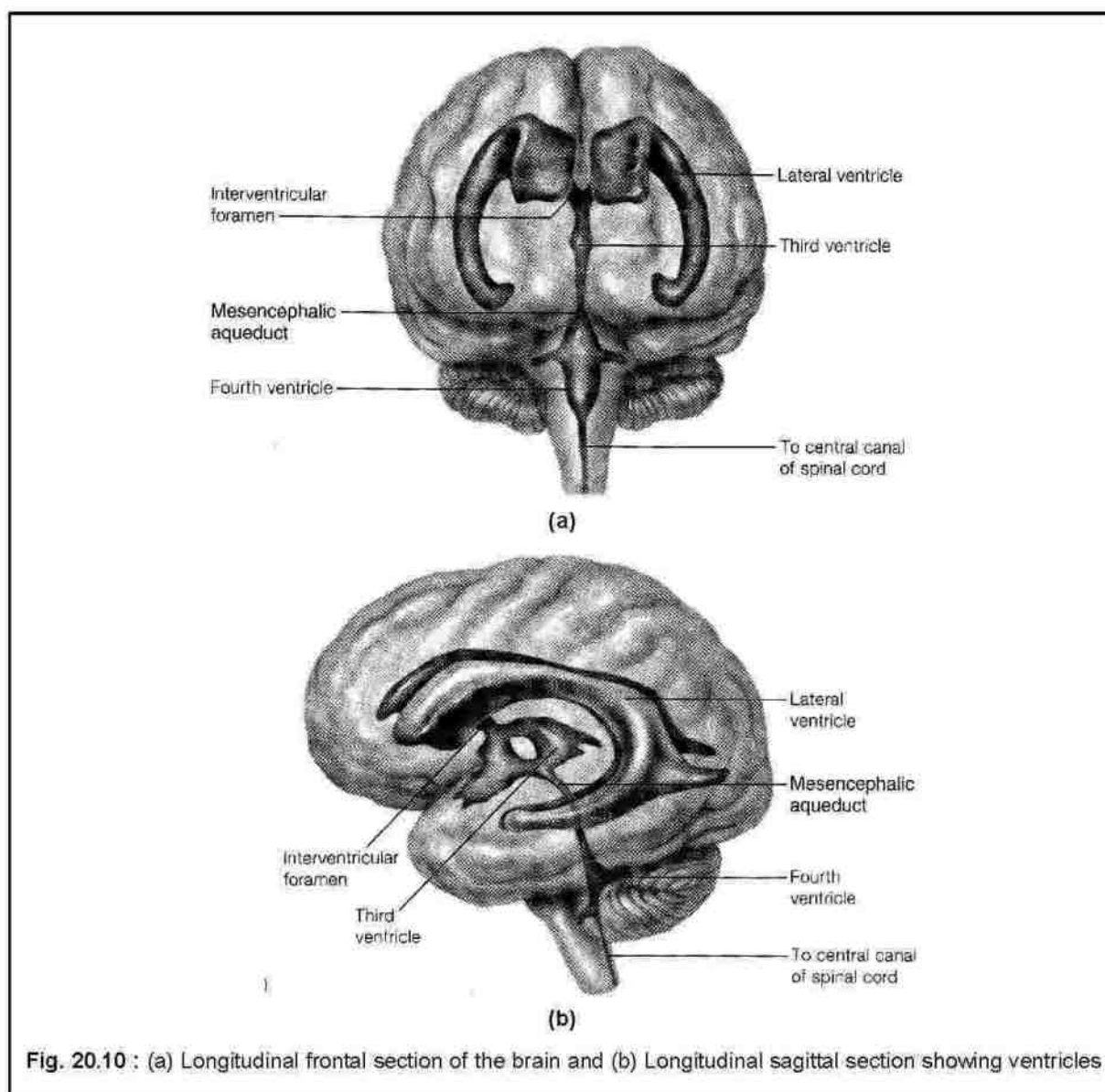

Fig. 20.10 : (a) Longitudinal frontal section of the brain and (b) Longitudinal sagittal section showing ventricles

**TABLE - 20.1**  
**FUNCTIONS OF THE BRAIN**

- I. **Cerebral Hemispheres (Cerebrum) :**
  1. Frontal Lobes
    - (i) Voluntary motor control of skeletal muscle.
    - (ii) Higher intellectual processes, such as thinking, planning and decision-making and verbal communication.
  2. Parietal Lobes
    - (i) Somesthetic (cutaneous and muscular) sensations.
    - (ii) Word formation for the expression of thoughts and emotions.
  3. Temporal Lobes
    - (i) Interpretation of auditory sensations.
    - (ii) Storage of auditory and visual experiences.
  4. Occipital Lobes
    - (i) Coordination of eye movements.
    - (ii) Correlation of visual images with previous visual experiences and other stimuli.
  5. Insula
    - (i) Memory encoding.
    - (ii) Integration of sensory information (e.g., pain) with visceral responses.
- II. **Diencephalon :**
  1. Thalamus
    - (i) Relay centre for sensory pathways to the cerebral cortex except smell.
    - (ii) Skeletal muscle coordination.
  2. Hypothalamus
    - (i) Regulates anterior pituitary gland.
    - (ii) Regulates eating and drinking behaviour.
    - (iii) Regulates reproductive behaviour, such as sexual arousal and performance.
    - (iv) Regulates sleep and wakefulness.
    - (v) Generation and regulation of circadian rhythm.
    - (vi) Regulates body temperature.
    - (vii) Participates in the generation of emotional behaviour, like anger, fear, pain and pleasure.
- III. **Brain Stem :**
  1. Midbrain
    - (i) Involved in visual reflexes.
    - (ii) Act as relay centre for auditory information.
  2. Pons
    - (i) Acts as relay centre for the somatic and motor fiber tracts between the brain and the spina cord.
    - (ii) Regulates respiratory functions in coordination with medulla oblongata.
  3. Medulla oblongata
    - (i) Acts as a relay centre for somatic and motor fiber tracts between the brain and spinal cord.
    - (ii) Regulates breathing and cardio-vascular functions.
- IV. **Limbic System :**
  - (i) Participates in the generation of emotional behaviour.
  - (ii) Plays an important role in different kinds of learning.

**TABLE - 20.2**  
**THE CRANIAL NERVES**

<b>Name</b>	<b>Fibers</b>	<b>Comments</b>
I. Olfactory nerve	Afferent	Tract of brain; not true nerve. Carries input from receptors in olfactory (smell) epithelium.
II. Optic nerve	Afferent	Tract of brain; not true nerve. Carries input from receptors in eye.
III. Oculomotor nerve	Efferent	Innervates skeletal muscles that move eyeball up, ddown, and medially and raise upper eyelid; innervates smooth muscles that constrict pupil and alter lens shape for near and far vision.
	Afferent	Transmits information from receptors in muscles.
IV. Trochlear nerve	Efferent	Innervates skeletal muscles that move eyeball downward and laterally.
	Afferent	Transmits information from receptors in muscle.
V. Trigeminal nerve	Efferent	Innervates skeletal chewing muscles.
	Afferent	Transmits information from receptors in skin; skeletal muscles of face, nose, and mouth; and teeth sockets.
	Afferent	Transmits information from receptors in muscle.
VI. Abducens nerve	Efferent	Innervates skeletal muscles that move eyeball laterally.
VII. Facial nerve	Afferent	Transmits information from receptors in muscle.
	Efferent	Innervates skeletal muscles of facial expression and swallowing; innervates nose, palate, and lacrimal and salivary glands.
	Afferent	Transmits information from taste buds in front of tongue and mouth.
VIII. Vestibulocochlear nerve	Afferent	Transmits information from receptors in ear.
IX. Glossopharyngeal nerve	Efferent	Innervates skeletal muscles involved in swallowing and parotid salivary gland.
	Afferent	Transmits information from taste buds at back of tongue and receptors in auditory-tube skin.
X. Vagus nerve	Efferent	Innervates skeletal muscles of pharynx and larynx and smooth muscle and glands of thorax and abdomen.
	Afferent	Transmits information from receptors in thorax and abdomen.
XI. Accessory nerve	Efferent	Innervates neck skeletal muscles.
XII. Hypoglossal nerve	Efferent	Innervates tongue skeletal muscles.

**20.2.1.3. Spinal Cord :** The brain lodged in the cranial cavity continues as the spinal cord behind. The last division of the brain, the medulla leaves the cranial cavity through **foramen magnum** of the occipital bone of the skull as the spinal cord. The spinal cord is secured in the neural canal of the vertebral column. Like that of the brain, the spinal cord is surrounded by three protective layers, namely **dura mater**, **arachnoid mater** and **pia mater** from outer to inner. The space between the arachnoid mater and pia mater (sub-arachnoid space) is filled with CSF. The cord extends from the foramen magnum to the disk between the first lumbar and second lumbar vertebra. There are two continuous longitudinal depressions, one each along the middorsal and midventral sides of the cord. These are known as **dorsal** and **ventral fissures**, respectively. The cone shaped terminal part of the cord is known as **conus medullaris**. A fine connective tissue filament, known as **filum terminale** is attached to the conus medullaris. There is a bunch of spinal nerves at the posterior end of the spinal cord. This bunch is known as **cauda equina**, that looks like a horse tail.

Unlike the brain, in which the grey matter forms a cortex over white matter, grey matter in the spinal cord is central, surrounded by white matter. The grey matter is in the shape of the English alphabet "H" with two **dorsal** and two **ventral horns** (Fig. 20.11). The white matter contains ascending (sensory) and descending (motor) myelinated fiber tracts. These tracts are

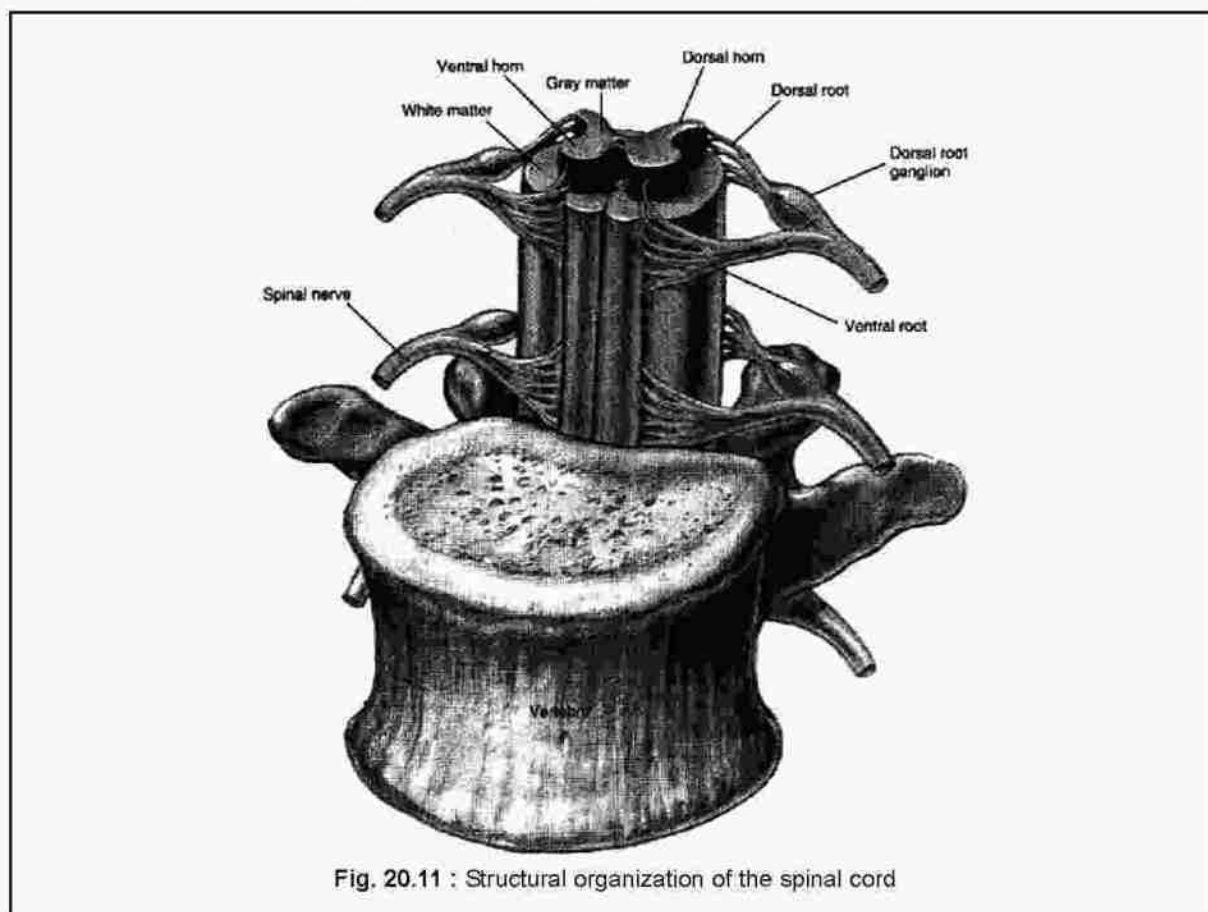

Fig. 20.11 : Structural organization of the spinal cord

arranged into six columns, known as **funiculi**. The names of the ascending tracts begin with the prefix **spino-** and end with the region of the brain, where it ends. Conversely, the names of descending tracts begin with the prefix denoting the brain region, where it begins and end with the suffix **-spinal**.

Groups of sensory (afferent) fibers from the peripheral nerves enter the spinal cord on the dorsal side via the dorsal roots. A swelling on each dorsal root, the **dorsal root ganglion** contains the cell bodies of the sensory or afferent neurons. The motor (efferent) fibers leave the spinal cord on the ventral side via the ventral roots. Some distance from the spinal cord, the two roots join to form a **spinal nerve** on each side.

### 20.2.2. Peripheral Nervous System (PNS) :

The PNS consists of the nerves arising from the brain (**cranial nerves**) and the nerves arising from the spinal cord (**spinal nerves**). There are **12 pairs of cranial nerves** and **31 pairs of spinal nerves** in human. The summary of the cranial nerves and the type of signals transmitted by each is presented in the following table. The nerve fibers of all these nerves transmit signals between the CNS and all other parts of the body. It is to be noted that all the nerve fibers of the PNS are myelinated. A complete communication cycle involves an input from a peripheral parts by sensory (afferent) pathway followed by and appropriate output to the peripheral part in question by a motor (efferent) pathway. Therefore, the PNS is conveniently studied under two divisions: the **sensory (afferent) division** and the **motor (efferent) division** (Fig. 20.12).

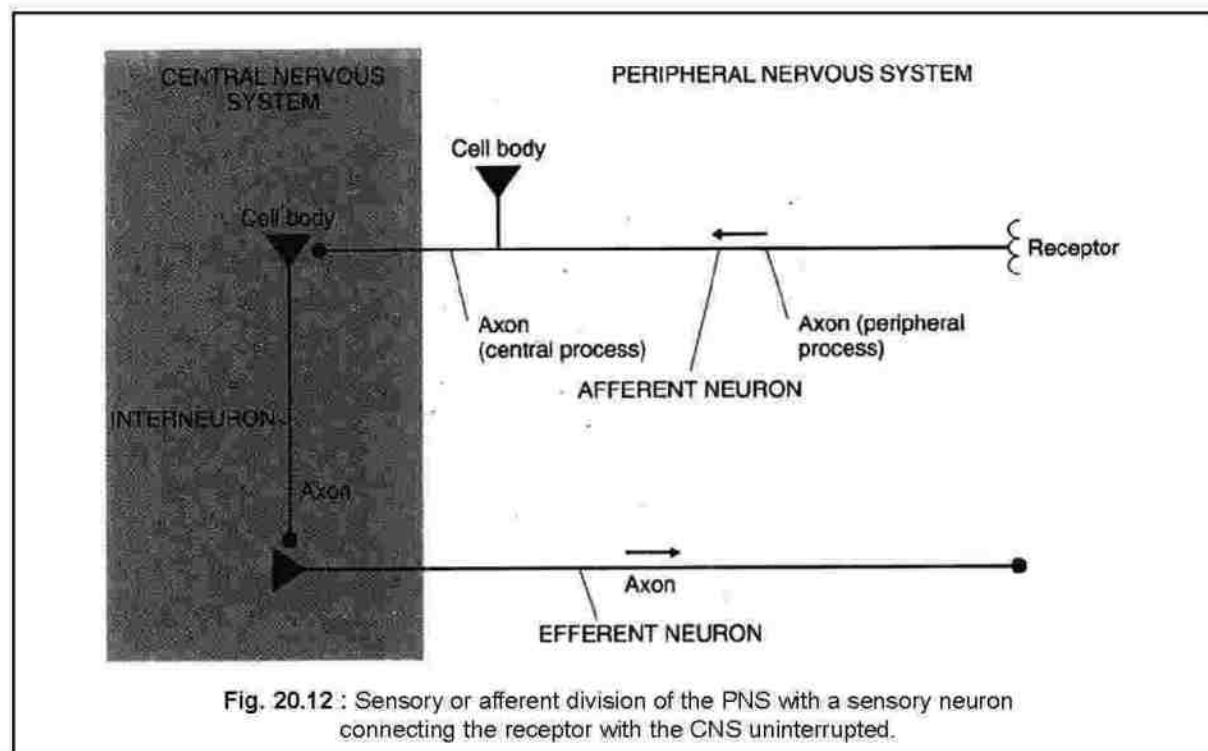
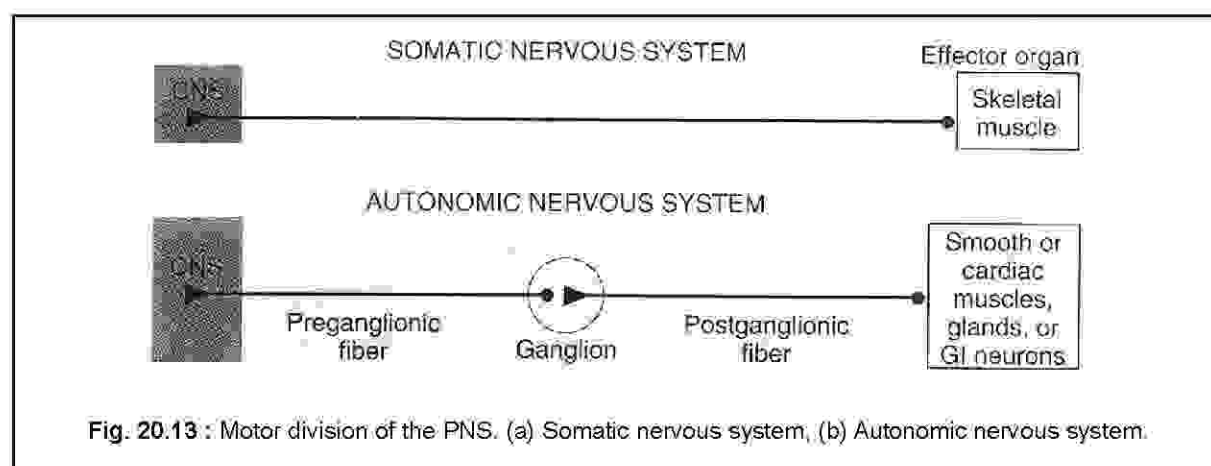

Fig. 20.12 : Sensory or afferent division of the PNS with a sensory neuron connecting the receptor with the CNS uninterrupted.

**20.2.2.1. Sensory (Afferent) Division:** As noted earlier, the sensory nerves convey information from the peripheral parts to the CNS. Such nerves consist of nerve fibers, which are classed as pseudounipolar neurons and whose cell bodies lie in the dorsal root ganglia outside the CNS. In fact, such a neuron has a very long axon divided into two parts: a peripheral part and a central part. The peripheral part makes its beginning at the receptor, travels a long distance uninterrupted and then terminates in a synapse with the dendrites in the CNS as a central part.

**20.2.2.2. Motor (Efferent) Division:** The motor (efferent) division of the PNS is more complicated than the sensory. It is divided into **somatic** and **autonomic nervous systems** (Fig. 20.13). The neurons of the somatic system innervate the skeletal muscle, while the autonomic neurons innervate the smooth muscle, cardiac muscle, glands and neurons in the gastrointestinal tract.



**(a) Somatic Nervous System:** It consists of all nerve fibers of the CNS innervating skeletal muscle. The cell bodies of these neurons are located in the brain stem or spinal cord. The myelinated nerve fibers leave the CNS and innervate skeletal muscle uninterrupted i.e. without a synapse. The neurotransmitters released by such neurons is acetylcholine.

**Autonomic Nervous System:** In this system, the innervation of the effector tissues and organs occur by two neurons and one synapse. The first neuron has its cell body in the CNS. The synapse is in an autonomic ganglion outside the CNS. The fiber preceding the synapse is known as **pre-ganglionic**, while the one succeeds the synapse is known as **post-ganglionic**. Autonomic nervous system is subdivided into **sympathetic** and **parasympathetic** divisions.

The sympathetic division consists of sympathetic fibers that leave the CNS from the thoracic and lumbar regions of the spinal cord and therefore, this division is also termed as **thoraco-lumbar division**. Most of the sympathetic ganglia lie close to the spinal cord and form two **chains of ganglia**, known as **sympathetic trunks** (Figs. 20.14 and 20.15). Other sympathetic ganglia called **collateral ganglia**, such as **celiac**, **superior mesenteric** and **inferior mesenteric ganglia** lie closer to the innervated organs. There are **22 sympathetic ganglia** in

each trunk. The parasympathetic fibers leave the CNS from the sacral region of the spinal cord and hence known as **cranio-sacral division**. In contrast to the sympathetic ganglia, the parasympathetic ganglia lie within the innervated organs by the post-ganglionic neurons. Acetylcholine is secreted as the neurotransmitter between pre- and post-ganglionic fibers in both the sympathetic and parasympathetic divisions. In the parasympathetic division, the major neurotransmitter between the post-ganglionic fiber and the effector organ or tissue is also acetylcholine. However, in the sympathetic division, the major neurotransmitter between the post-ganglionic fiber and the effector is nor-epinephrine.

Autonomic responses occur without conscious control or awareness and therefore, this part of the nervous system has also been termed as **involuntary nervous system**.

### 20.3. REFLEX ACTION :

The functions of the sensory and motor divisions of the PNS is explained by considering **reflex action**. It is an unconscious motor response to a sensory stimulus. When a sensory receptor is stimulated by an appropriate stimulus, action potential is generated in the membrane of the sensory nerve fiber (neuron), which propagates to the spinal cord as an impulse. The axon or fiber of this neuron passes through the dorsal root of the spinal nerve. The cell body of this neuron is situated in a swollen part of the dorsal root known as the **dorsal root ganglion**. The neuron then synapses with the dendrites of another neuron called **interneuron** or **association neuron** or **integrator neuron** in the grey matter. The axon of the interneuron synapses with the dendrites of another neuron called **motor neuron** also in the grey matter of the spinal cord. The motor neuron sends a fiber

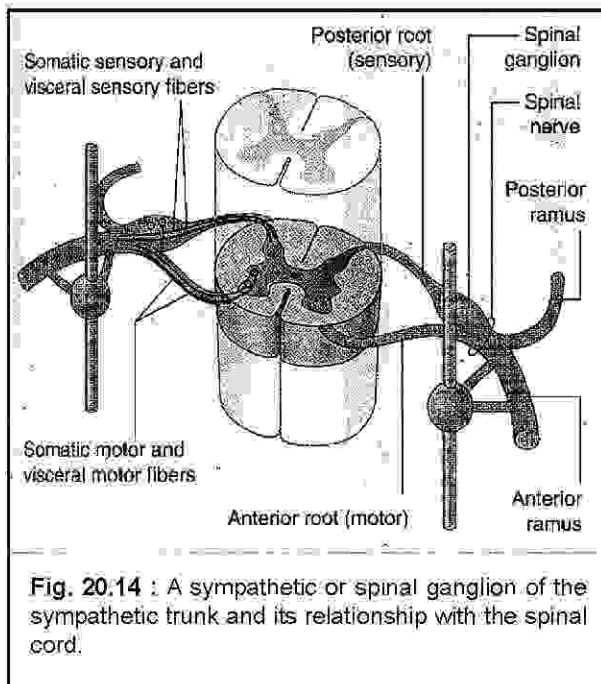

Fig. 20.14 : A sympathetic or spinal ganglion of the sympathetic trunk and its relationship with the spinal cord.

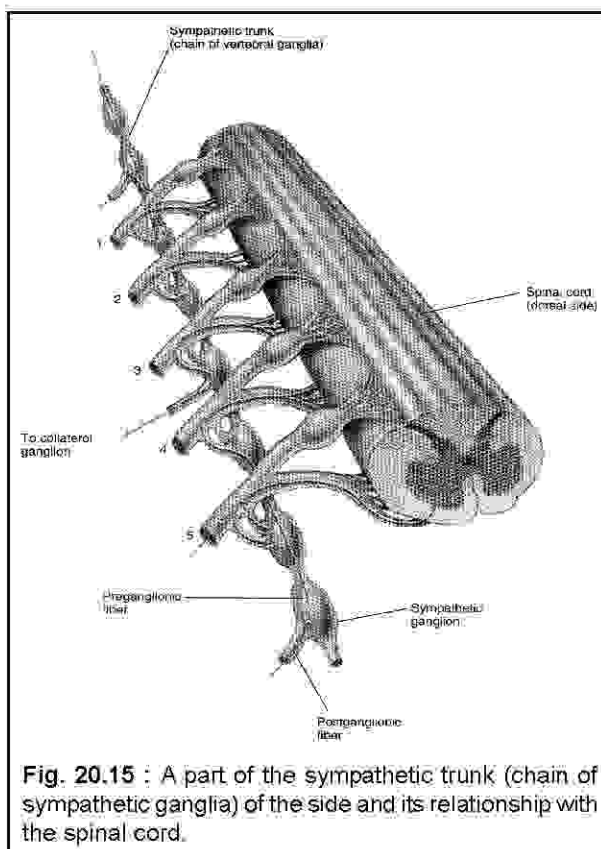
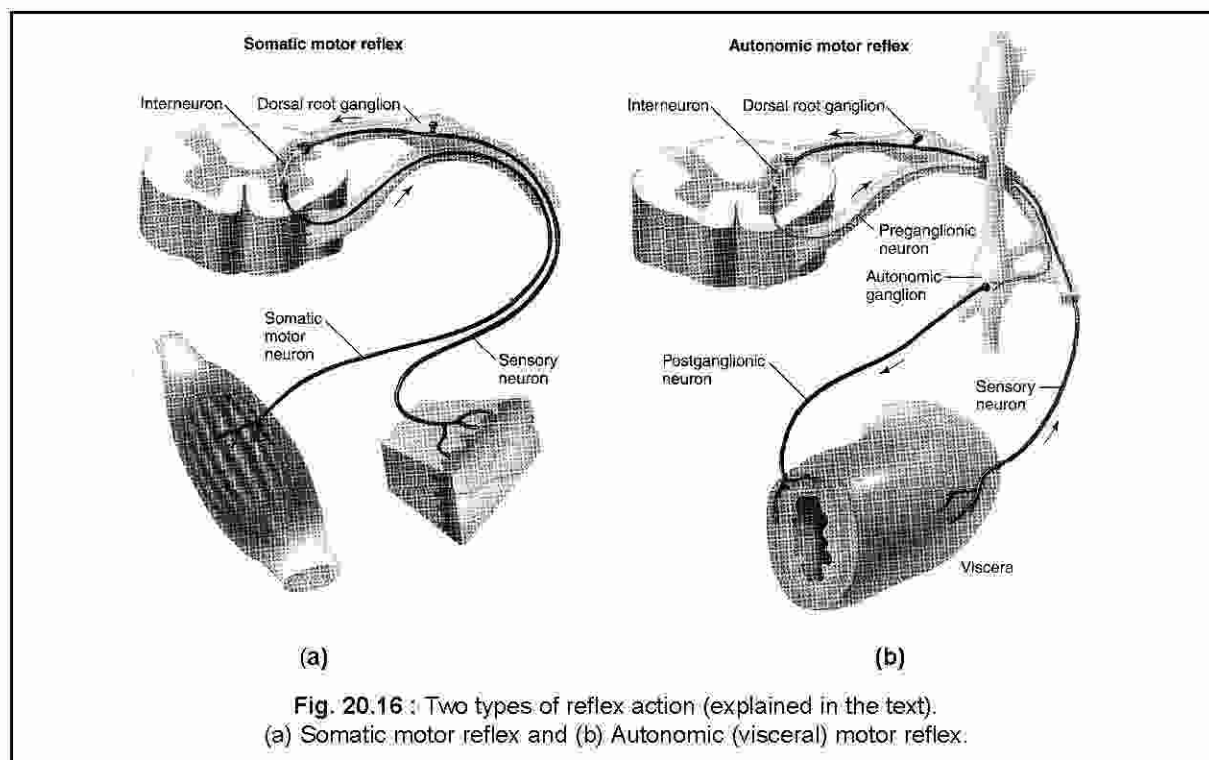

Fig. 20.15 : A part of the sympathetic trunk (chain of sympathetic ganglia) of the side and its relationship with the spinal cord.

through the **ventral root**, which innervates an effector (skeletal muscle or other effector tissues or organs). The brain is not directly involved in this response. Thus the impulse travels from the receptor to the effector describing a complete path and this path is known as a **reflex arc**. There are two fundamental types of reflex action: **somatic motor reflex** and **autonomic (visceral) motor reflex** (Fig. 20.16).



In somatic motor reflex, a somatic motor neuron conducts the impulse along a single axon from the spinal cord to the neuromuscular junction of a skeletal muscle (effector) [Fig. 20.16 (a)]. On the contrary, the autonomic motor control is executed by two neurons, of which the first neuron, known as the pre-ganglionic which has its cell body in the grey matter of the brain or spinal cord. The axon synapses with another neuron, the post-ganglionic in a ganglion called **sympathetic (autonomic) ganglion**. The post-ganglionic neuron synapses with the target effector tissue or organ (cardiac muscle, smooth muscle and glands) [Fig. 20.16 (b)].

#### 20.4. CONDUCTION OF NERVE IMPULSE :

It has been indicated in the preceding discussion that the conduction of nerve impulse is **partly electrical and partly chemical**. When it is along an axon, it is carried by an electrical phenomenon, but when it is carried from one neuron to the next across a functional junction (synapse), it is by a chemical phenomenon. Before we take up with the origin of an electrical signal in the axon membrane, let's understand about the distribution of ions (electrical charges) in both the intra- and extra-cellular aqueous environments of the neuron.



Positively charged and negative charged ions are distributed unequally between these two aqueous environments of almost all cells including the neurons. The plasma membrane stands as a selectively permeable barrier between the two environments. Ions can't crossover from one side to the other freely. However, a class of ions is only allowed to crossover at an appropriate time. This unequal distribution of ions between two sides of the plasma membrane creates a potential difference across the membrane, which is termed as **membrane potential** (electric potential of the membrane). The unit of electric potential is volt (V) and since this potential in living system is very small, it is expressed in millivolt (mV).

#### 20.4.1. Resting membrane potential :

All cells, at rest, maintain a potential difference across the plasma membrane, in which the inner side is negatively charged in comparison to the outer side. This potential is the resting membrane potential. Neurons maintain this potential at  $-70\text{mV}$ .  $\text{Na}^+$  is more highly concentrated in the extracellular fluid than in the inner side, whereas  $\text{K}^+$  is more highly concentrated on the inner side. The inner side of the membrane is negatively charged relative to the outer side.

Although all cells maintain a membrane potential, only a few have the property of altering the resting membrane potential at a small section of the membrane in response to a stimulus. Such alterations occur by changing the membrane permeability to specific ions such as  $\text{Na}^+$  and  $\text{K}^+$ . These ions crossover down their gradient (downhill) through ion channels of the membrane. (However, during their crossingover against the gradient (uphill), ion specific enzymes and ATP are required.) The altered potential propagates along the axon of the neuron. This property has been termed as **excitability**. It is a unique property of neurons and muscle cells. The altered membrane potential has been termed as **action potential (AP)**. The propagation of the nerve impulse or in a better sense the action potential is unidirectional and occurs along the axon away from the cell body i.e. towards a synapse. The origin and propagation of action potential takes place in three steps: (1) **depolarization**; (2) **repolarization**; and (3) **reorientation**.

#### 20.4.2. Depolarization [Fig. 20.17 (a)] :

As mentioned earlier that in a resting neuron membrane the  $\text{Na}^+$  concentration is more on the outer side than on the inner side with the inner side having more negative charges. The membrane potential is measured at  $-70\text{mV}$ . When the membrane is stimulated, the sodium ion channels open allowing  $\text{Na}^+$  to crossover down its gradient. No metabolic energy of ATP is spent.  $\text{Na}^+$  concentration on the inner side builds up and the negative charges decrease. Conversely, the  $\text{Na}^+$  concentration on the outer side decreases and the positive charges decrease. This influx of  $\text{Na}^+$  continues till the membrane potential is increased to  $+30$ . The electrical charges across the membrane at the site of stimulation is reversed transiently resulting in the formation of an action potential. This reversal of the membrane potential by the influx of  $\text{Na}^+$  is known as **depolarization**.

**20.4.3. Repolarization [Fig. 20.17 (b)] :**

Following depolarization, there is an efflux of  $K^+$  (outward movement) through potassium ion channels down its gradient and hence metabolic energy of ATP is not spent. The  $K^+$  concentration builds up on the outer side of the neuron membrane decreasing the negative charges. Conversely, there is a decrease in the  $K^+$  concentration in the intracellular environment resulting in a build up of negative charges. This process continues till the membrane potential again becomes  $-70$  mV. This restoration of the membrane potential to a resting potential state by the efflux of  $K^+$  is known as repolarization.

**20.4.4. Reorientation [Fig. 20.17 (c)]:**

Following repolarization, the membrane potential is restored at resting potential state i.e., at  $-70$  mV. The ionic distribution is reversed relative to that in the resting membrane i.e. there is more  $Na^+$  and  $K^+$  in the intra and extracellular environments, respectively. The normal orientation is achieved by a process known as reorientation. The  $Na$  and  $K^+$  exchange their places. However, this time, the flow of ions is against their concentration gradients. For this work, metabolic energy is spent. A membrane bound  $Na^+ - K^+$  ATPase pump does the work at the expense of metabolic energy. At the end of the reorientation process, the normal polarity in respect of ionic distribution is reached with the membrane potential at  $-70$  mV.

**20.4.5. Types of Conduction :**

We have learnt that there are two types of nerve fibers, namely myelinated and unmyelinated, based on the presence or absence of myelin sheaths. In accordance with this, two types of conduction have been explained.

**20.4.5.1. Conduction along unmyelinated fiber:** In unmyelinated nerve fibers, the axons are unsheathed or naked without myelin sheaths. An action potential is generated in the membrane at the site of stimulation. The membrane undergoes depolarization by a rapid influx of  $Na^+$ . This is followed by repolarization by an efflux of  $K^+$ . Concomitant with the repolarization of this part of the membrane, the adjoining forward part of the membrane is depolarized. Like

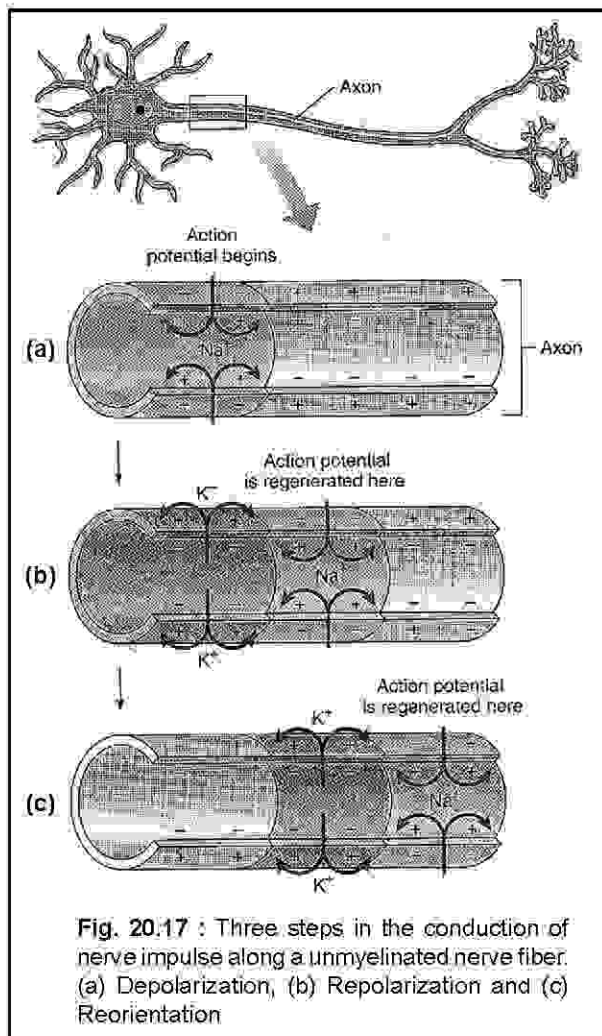

Fig. 20.17 : Three steps in the conduction of nerve impulse along a unmyelinated nerve fiber. (a) Depolarization, (b) Repolarization and (c) Reorientation

this there is a wave of depolarization and repolarization in a forward direction in an electrifying speed. This is explained as the propagation of action potential and hence nerve impulse (Fig. 20.17).

**20.4.5.2. Conduction along myelinated fiber:** In myelinated nerve fiber, the axons are discontinuously sheathed by myelin sheaths at regular intervals. This leaves unsheathed nodes called **nodes of Ranvier**. Depolarization and repolarization of the axon membrane takes place only at these nodes. When the membrane at a node is depolarized and then repolarized, the adjoining node is depolarized. Thus the action potential moves from node to node. This type of conduction is known as **jumping or saltatory conduction** (Fig. 20.18).

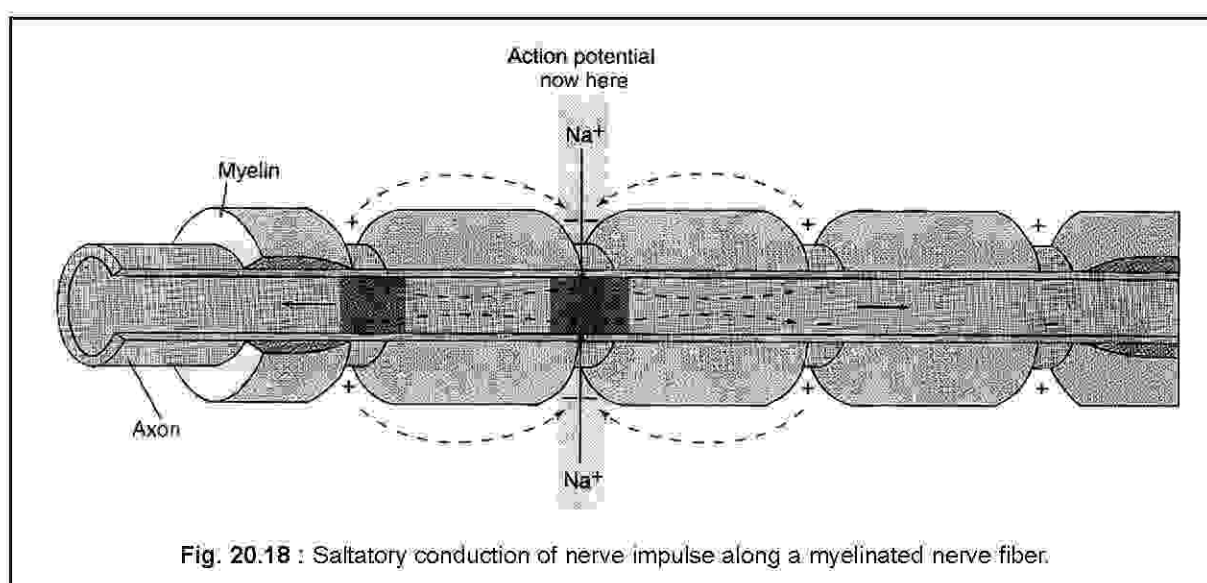

Fig. 20.18 : Saltatory conduction of nerve impulse along a myelinated nerve fiber.

#### 20.4.6. Synaptic Transmission :

The nerve impulse in one fiber travels in one direction i.e. from the cell body along the axon to the axon terminal. The axon terminal forms a junction or synapse with the denrite of the next neuron. On reaching the axon terminal, the impulse is transmitted to the next neuron through the synapse. This transmission is known as **synaptic transmission**.

We have mentioned about two types of synapses such as electrical and chemical in the preceding section and we have also discussed that at the chemical synapse, the electrical potential (action potential) of the presynaptic neuron changes into a chemical signal. The chemical signal is known as a neurotransmitter, which is synthesized and stored in the synaptic vesicles of the presynaptic axon terminal. On getting a depolarization stimulus, the vesicles release the neurotransmitter into the synaptic cleft. Following its release, the following events take place in the membrane of the postsynaptic neuron.

1. An excitatory neurotransmitter, following its release, binds to the receptors on the postsynaptic membrane. This binding brings about a depolarization of the membrane.

2. The depolarization causes the opening of voltage regulated ion channels of the membrane.
3. Opening of ion channels facilitates the influx and outflux of ions. This produces an action potential in the postsynaptic membrane.
4. The depolarization stimulus of one region serves as a stimulus for the next region and the consequence is the propagation of the action potential in a forward direction. The propagation of the action potential is what we know as conduction of nerve impulse.

#### Classes of Neurotransmitters:

1. Acetylcholine
2. Biogenic amines: [Epinephrine, Norepinephrine, Dopamine, Serotonin and Histamin]
3. Aminoacids: [Aspartate, Glutamate, Glycine and Gamma aminobutyric acid (GABA)]
4. Neuropeptides: [Endorphins, Dynorphins and Enkephalins]
5. Gases: Nitric oxide (NO) and Carbon monoxide (CO)

### 20.5. SENSE ORGANS AND PERCEPTION :

The perception of the world through touch, taste, smell, hearing and vision is made through sensory receptors contained in sense organs. These organs change different forms of energy into nerve impulses, which are conducted to the CNS by sensory neurons. The brain then interprets these impulses into perceptions. The perceptions enable the individual to understand the environment around and allow interacting with the environment in an effective manner. There are five receptors, we need to discuss about. These are:

1. **Sense of touch (Cutaneous Sensation)**
2. **Sense of taste (Gustation)**
3. **Sense of smell (Olfaction)**
4. **Sense of equilibrium and balancing and hearing**
5. **Sense of vision**

#### 20.5.1. Sense of touch (Cutaneous Sensation) (Fig. 20.19) :

The skin serves as the receptor of touch, pressure, temperature (heat and cold) and pain. Sensations to these stimuli are mediated by dendritic nerve endings of several neurons. The receptors for heat, cold and pain are the naked endings of sensory neurons. Sensations of touch are mediated by naked dendritic endings surrounding hair follicles and expanded dendritic endings called **Ruffini endings** and **Merkel's discs**. The sensations of touch and pressure are

mediated by encapsulated dendrites forming **Meissner's corpuscles** and **pacinian corpuscles**. The receptors for cold are located in the upper part of dermis, while warm receptors are located in the deeper part of the dermis. **Nociceptors (receptors of pain)** are free sensory nerve endings of myelinated or unmyelinated fibers.

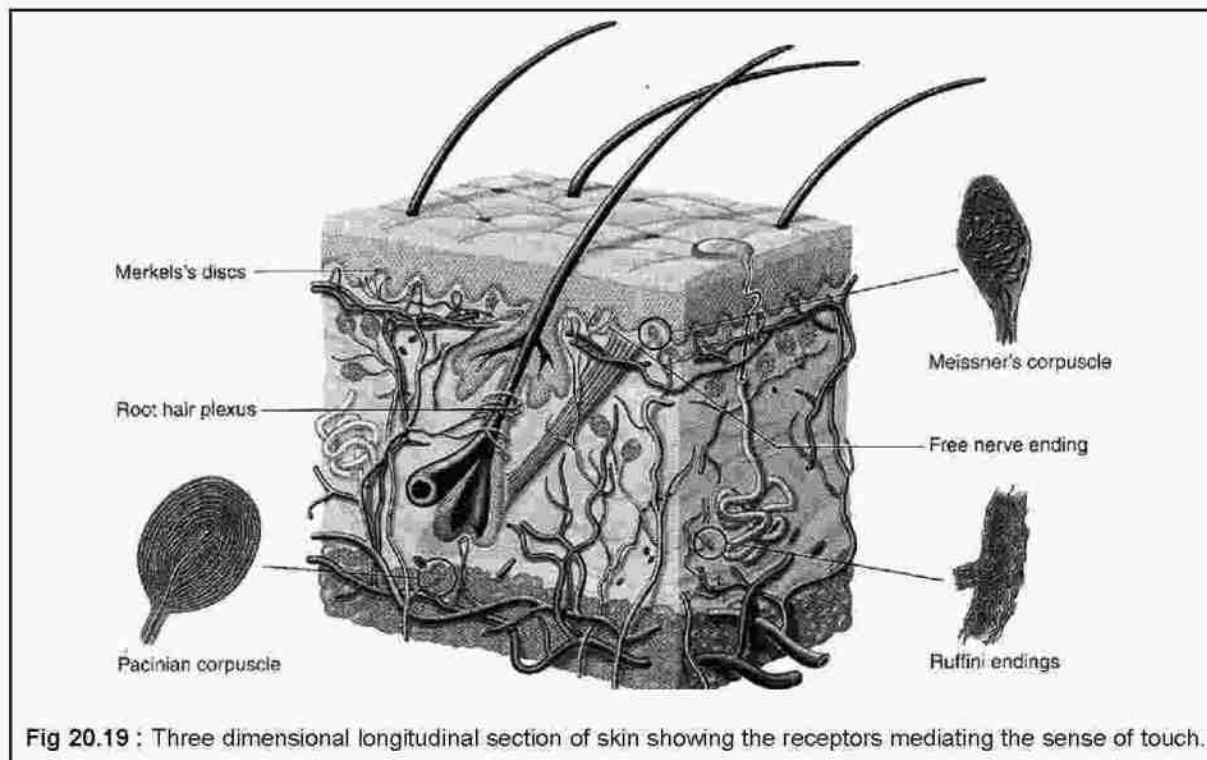

Fig 20.19 : Three dimensional longitudinal section of skin showing the receptors mediating the sense of touch.

### 20.5.2. Sense of Taste (Gustation) :

The sense of taste or gustation is perceived by barrel shaped **taste buds** (Fig. 20.20), present on the dorsal side of the tongue. A taste bud consists of 50 to 100 specialized epithelial cells with long microvilli that extend through the pore to the external environment. The microvilli are in contact with saliva. Although these cells are not neurons, they behave as neurons when they are stimulated. They undergo depolarization and release neurotransmitter, which stimulates sensory neurons associated with the bud. The specialized epithelial

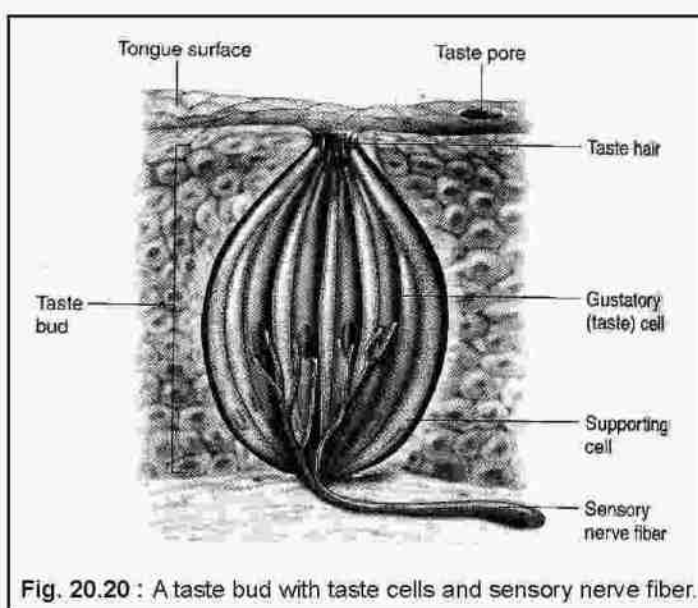

Fig. 20.20 : A taste bud with taste cells and sensory nerve fiber.

cells of the bud are known as **taste cells**. It was long believed that different regions of the tongue were specialized for different tastes, namely salty, sour, sweet and bitter. However, it is now established that each taste bud contains **taste cells** responding to each of the different tastes.

### 20.5.3. Sense of Smell (Olfaction) :

The receptors for the sense of smell are located in the olfactory epithelium, the internal lining of the olfactory apparatus (nasal canal). The olfactory apparatus consists of **receptor cells (bipolar neuron)**, **supporting (sustentacular) cells** and **basal (stem) cells** (Fig. 20.21). The basal cells regenerate new receptor cells to replenish the lost cells. The supporting cells are epithelial cells rich in enzymes that oxidize the hydrophobic (lipid soluble) odorants and make these molecules less lipid soluble thereby preventing their entry into the brain.

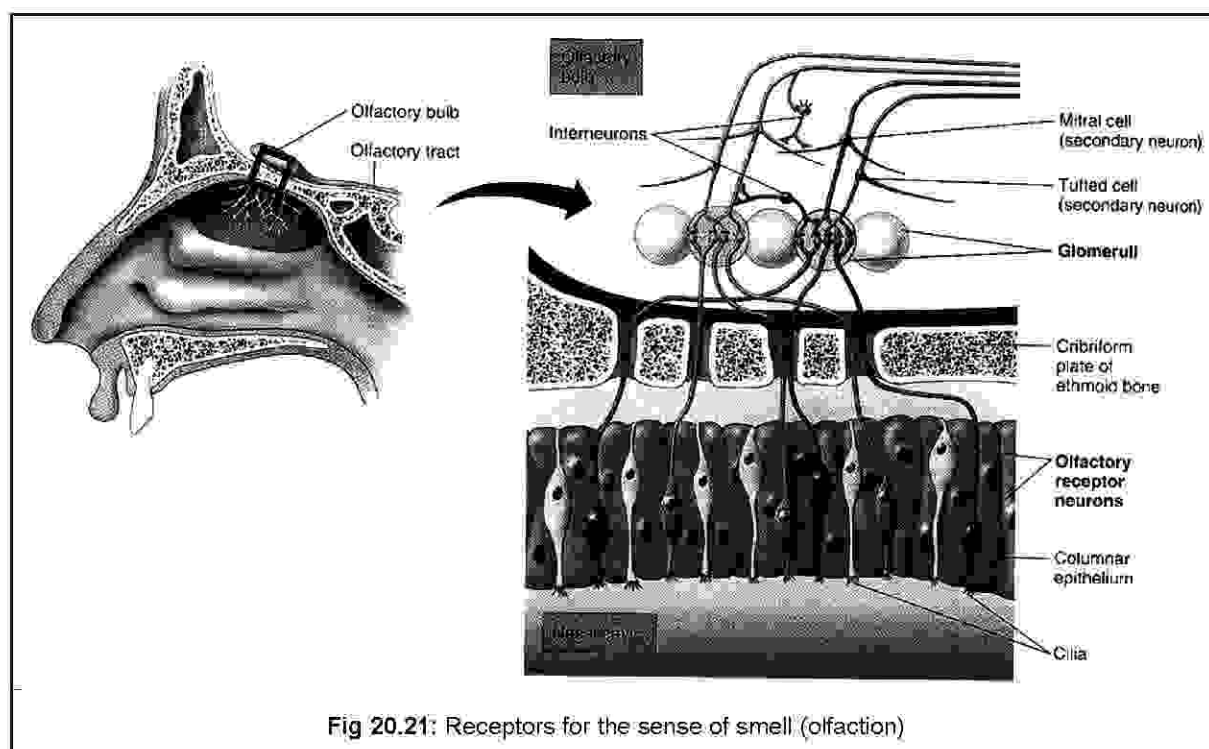
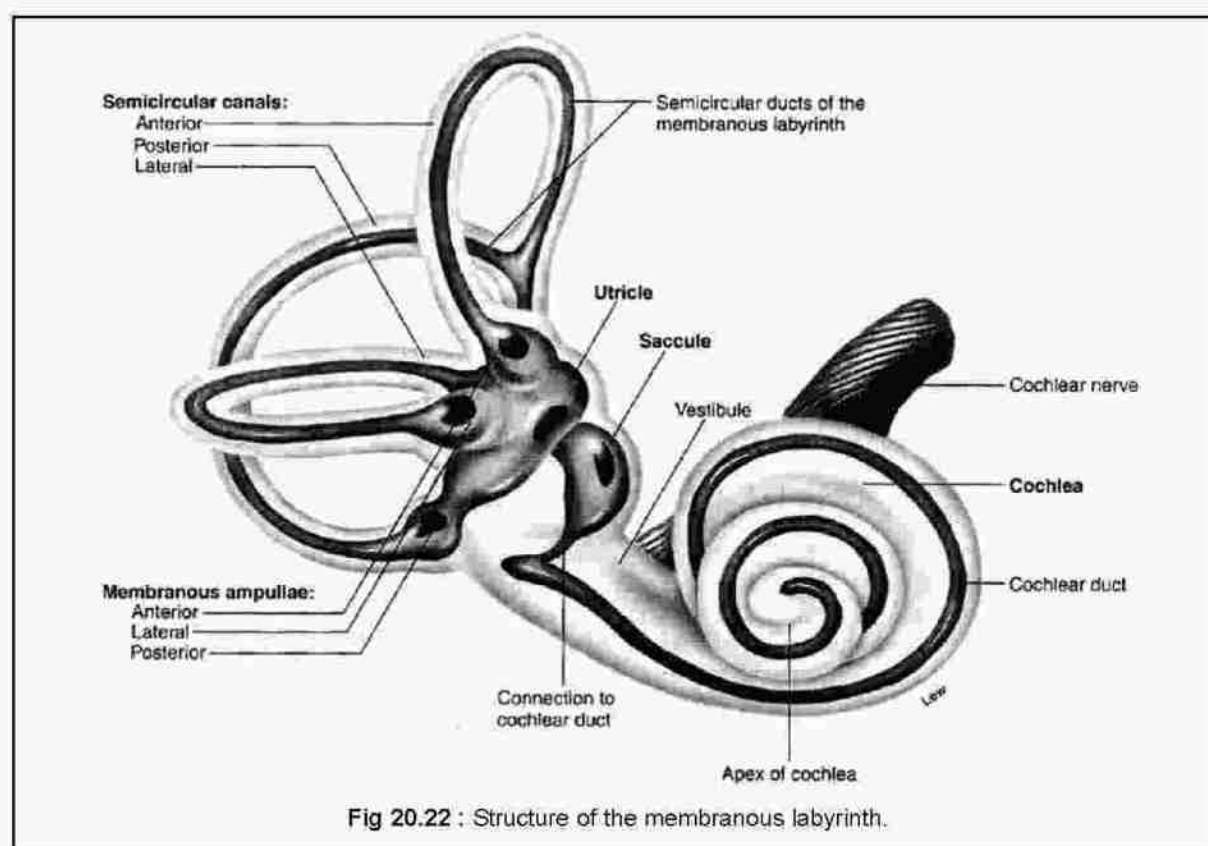

Fig 20.21: Receptors for the sense of smell (olfaction)

A receptor cell is a bipolar neuron, which has one dendrite, that projects into the nasal cavity. It terminates as a knob bearing cilia. The sensory cilia project into the nasal cavity. There is a single unmyelinated axon, which projects into the olfactory bulb through pores in the cribriform plate of the ethmoid bone. The axon of the receptor cell synapses with dendrites of neurons of the olfactory bulb, known as second-order neurons. The neurons of the olfactory bulb are arranged spherically forming characteristic structures known as **glomeruli**. The axons of these neurons move as a tract into the cerebral cortex, associated with hippocampus and amygdala. Unlike other sensory information, which are relayed to the cerebrum via the thalamus, olfactory information are relayed directly to the cerebrum.

#### 20.5.4. Vestibular Apparatus and Equilibrium :

Equilibrium or orientation with respect to gravity is controlled by the **vestibular apparatus**. The apparatus consists of two parts: an **otolith** constituted by **utricle and saccule** and three **semicircular canals** (Fig. 20.22). The sensory structure of the vestibular apparatus and cochlea (concerned with hearing) are situated within a **membranous labyrinth**, filled with a fluid, the **endolymph**. The membranous labyrinth is situated in a bony cavity of the skull, known as the **bony labyrinth**. There is a fluid called **perilymph** between the membranous labyrinth and bony labyrinth. Perilymph is similar in composition to the cerebrospinal fluid. Utricle, saccule and the crista ampullaris of the semicircular canals, contain receptor cell.



The receptors for equilibrium are modified epithelial cells, known as **hair cells** because of the presence of 20 – 50 hair like processes in each. All but one of these processes are **stereocilia** i.e. each has a protein filament surrounded by plasma membrane. The larger process is a true cilium, known as the **kinocilium** [Fig. 20.23 (a)]. When stereocilia are bent in the direction of the kinocilium, the plasma membrane is depressed and becomes depolarized [Fig. 20.23 (b)]. This causes the release of a neurotransmitter by the hair cells. The neurotransmitter stimulates the dendrites of sensory neurons that form a part of the vestibulo-cochlear nerve (VIII). When the stereocilia are bent in an opposite direction, the membrane is hyperpolarized

and such cells release another neurotransmitter [Fig. 20.23 (c)]. This substance stimulates the sensory neurons of the same nerve in a different manner. Thus the hair cells are stimulated and transmit the body balance information to the CNS via the **vestibulo-cochlear nerve**.

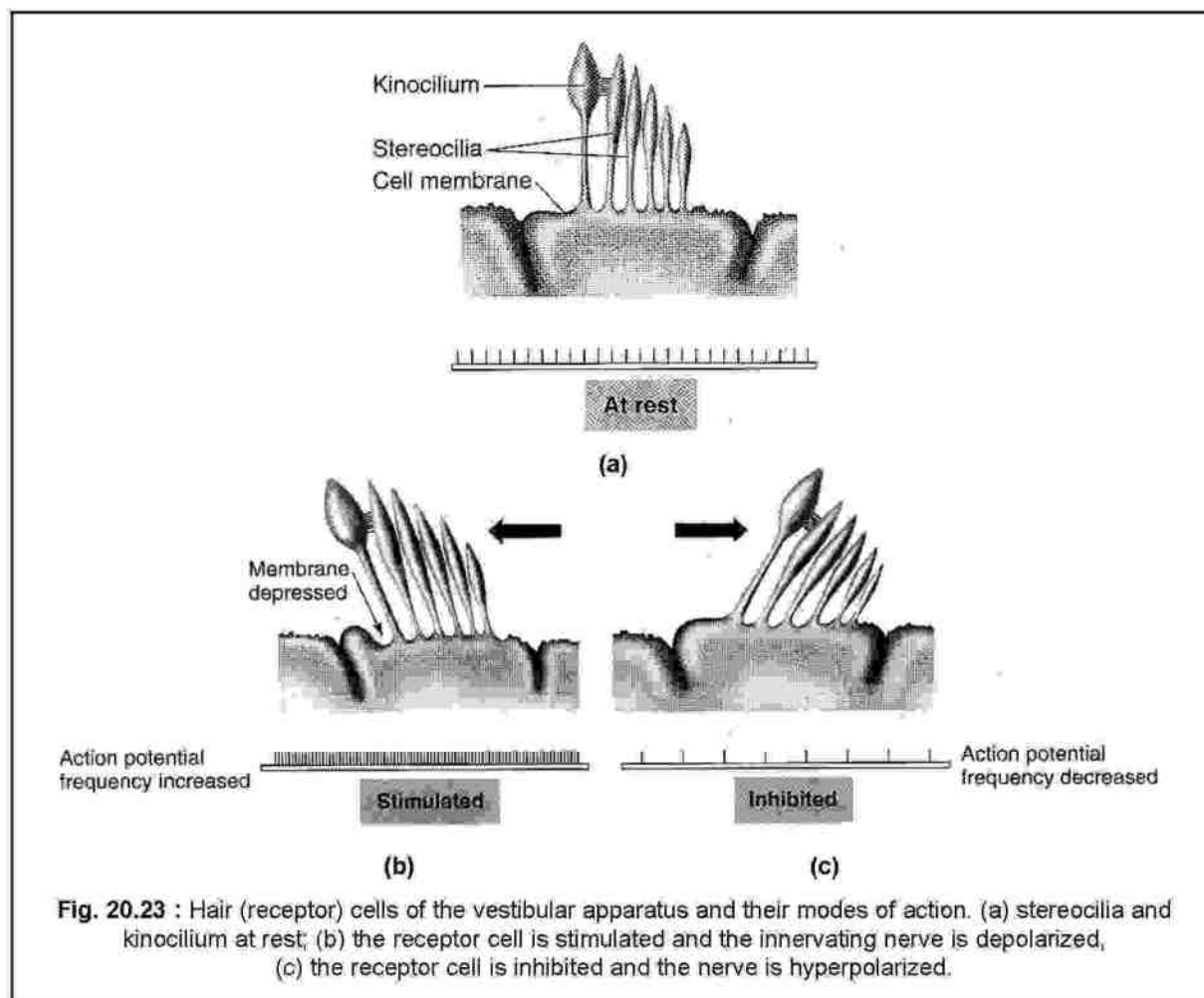

**20.5.4.1. Utricle and Saccule:** The utricle and saccule, each have a stretch of specialized epithelium, known as **macula**. The macula consists of **hair cells** and **supporting cells**. The hair cells project into the endolymph with the hairs embedded in a gelatinous membrane, known as **otolithic membrane**. The membrane contains micro-crystals of calcium carbonate. **The utricle regulates horizontal acceleration, while the saccule, vertical acceleration because of the differential orientations of the hairy processes into the otolithic membrane.** During forward acceleration, the otolithic membrane is drawn behind, pushing the hairs behind. Similarly, when there is a sudden brake on the acceleration, the hairs move forward. Likewise, when an aircraft takes off the ground, the hairs are pressed against the otolithic membrane and when a person descends in an elevator, the opposite effects take place. In every situation, there is a changed pattern in the action potential in the sensory nerve so as to maintain an equilibrium





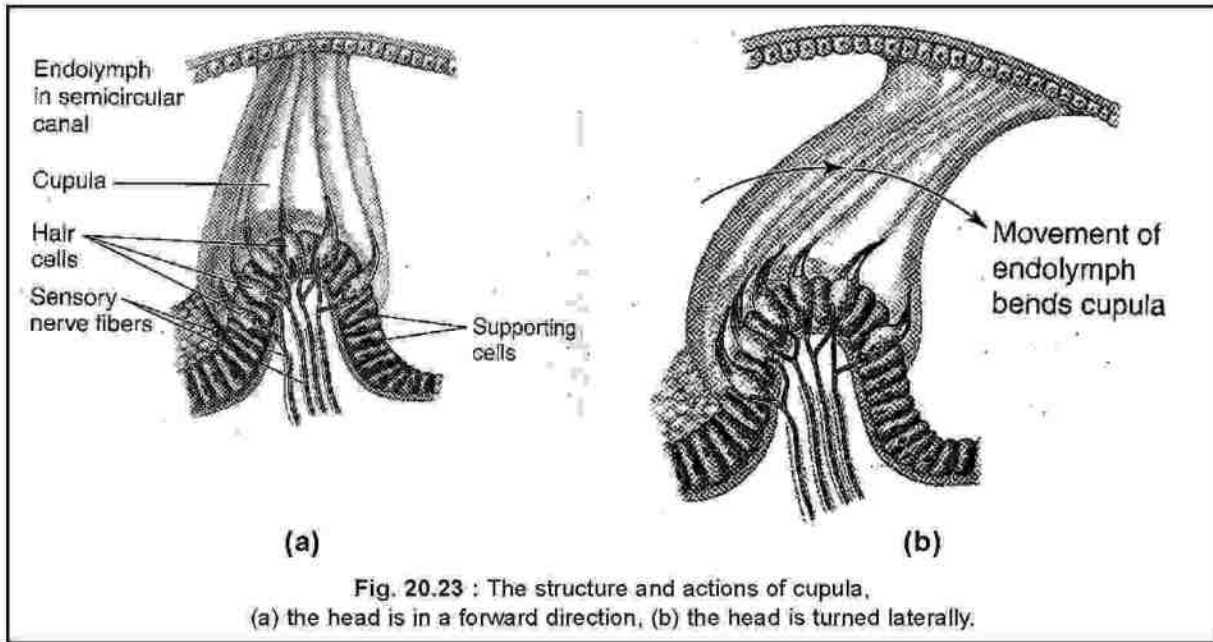

**20.5.5. Sense of hearing :**

There is a pair of ears as the organs of hearing. Each ear is divided into three divisions, namely; 1. External ear, 2. Middle ear and 3. Internal ear (Fig. 20.26).

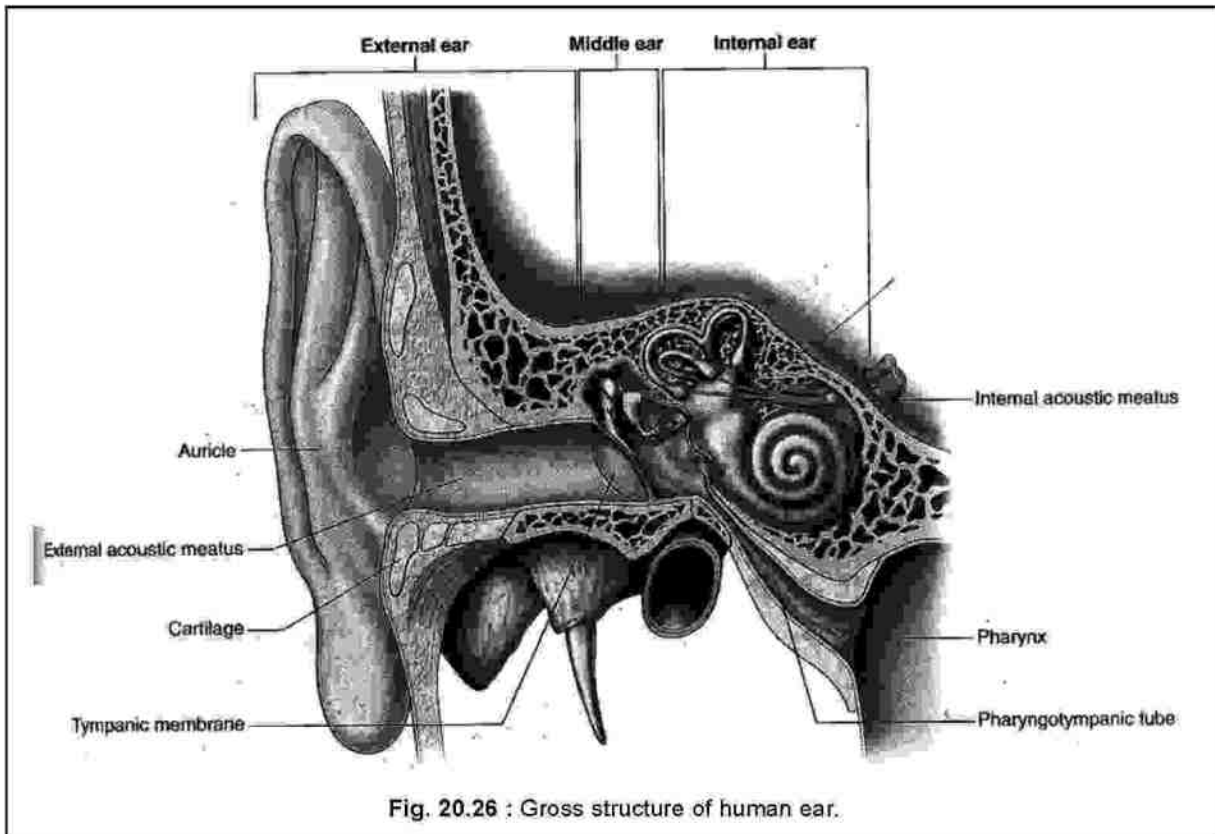

**20.5.5.1. External ear :** The external ear consists of two parts: the **pinna** or **auricle** and the **external auditory canal** or **external auditory meatus** (Fig. 20.26). The pinna is a funnel like external extension from the base of the ear cavity, supported by muscle and elastic cartilages. The pinna stands as a funnel, which traps the sound waves and transmits these into the middle ear through the external auditory meatus.

**20.5.5.2. Middle ear :** The middle ear is that part of the ear, which is between the **tympanic membrane (ear drum)** on the outer side and the **cochlea** on the inner side. The tympanic membrane separates the external auditory meatus from the middle ear cavity, an air filled cavity in the temporal bone of the skull. There are three bony **ear ossicles**, namely **malleus (hammer)**, **incus (anvil)** and **stapes (stirrup)** in this cavity (Fig. 20.27). The malleus is attached to the tympanic membrane so that vibrations of this membrane are perceived by the malleus, which then transmits these to the stapes via the incus. The stapes, in turn is attached to a membrane of the cochlea, the **oval window**. The vibrations of the tympanic membrane are transmitted to

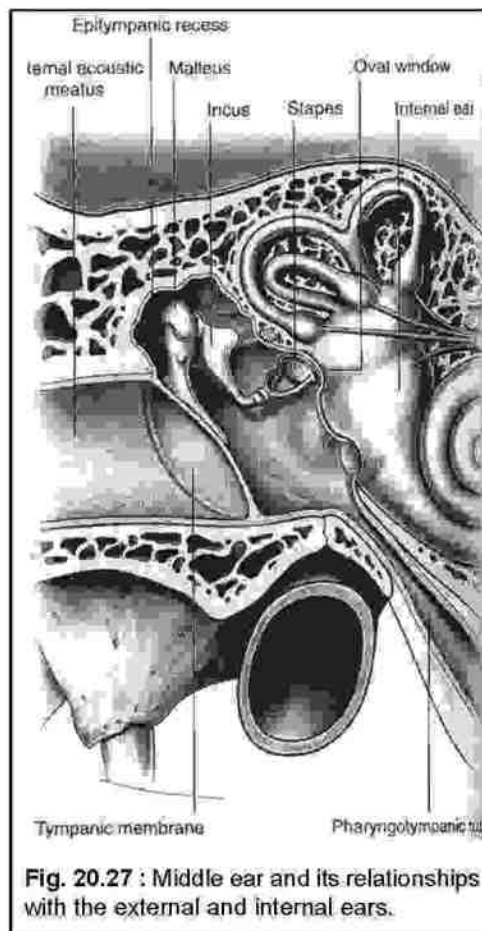

**Fig. 20.27 :** Middle ear and its relationships with the external and internal ears.

the oval window through these three bones instead of just one explains about the protection of the nerve from damage in the event of high intensity sound. If the sound is too intense, the ossicles may buckle. The protection is increased by the **stapedius muscle**, which attaches to the neck of the stapes. High intensity sound stimulates this muscle to contract so that the stapes moves and detaches from the oval window. The middle ear communicates with the nasopharynx through a tubular duct, known as the **eustachian tube** or **auditory tube**. The tube helps maintain an equilibrium in the air pressure between the middle ear and nasopharynx.

**20.5.5.3. Internal ear :** The internal ear is constituted by the vestibular apparatus and cochlea. Both the structures lie in a dense bony capsule of the temporal bone of the skull, known as bony labyrinth. The vestibular apparatus is concerned with the act of equilibrium and balancing of the body, while the cochlea with hearing (Fig. 20.22). The part of the internal ear (membranous labyrinth) is already described in the maintenance of body balance and equilibrium.

**20.5.5.4. Cochlea (Fig. 20.28) :** The cochlea is about the size of a pea and is shaped like the spiral of a snail having three turns: apical, middle and basal. The cochlea is almost divided lengthwise into three fluid filled compartments by a fluid filled membranous tube, the **cochlear duct**. Other two compartments are: **scala vestibuli** and **scala tympani**, the cochlear

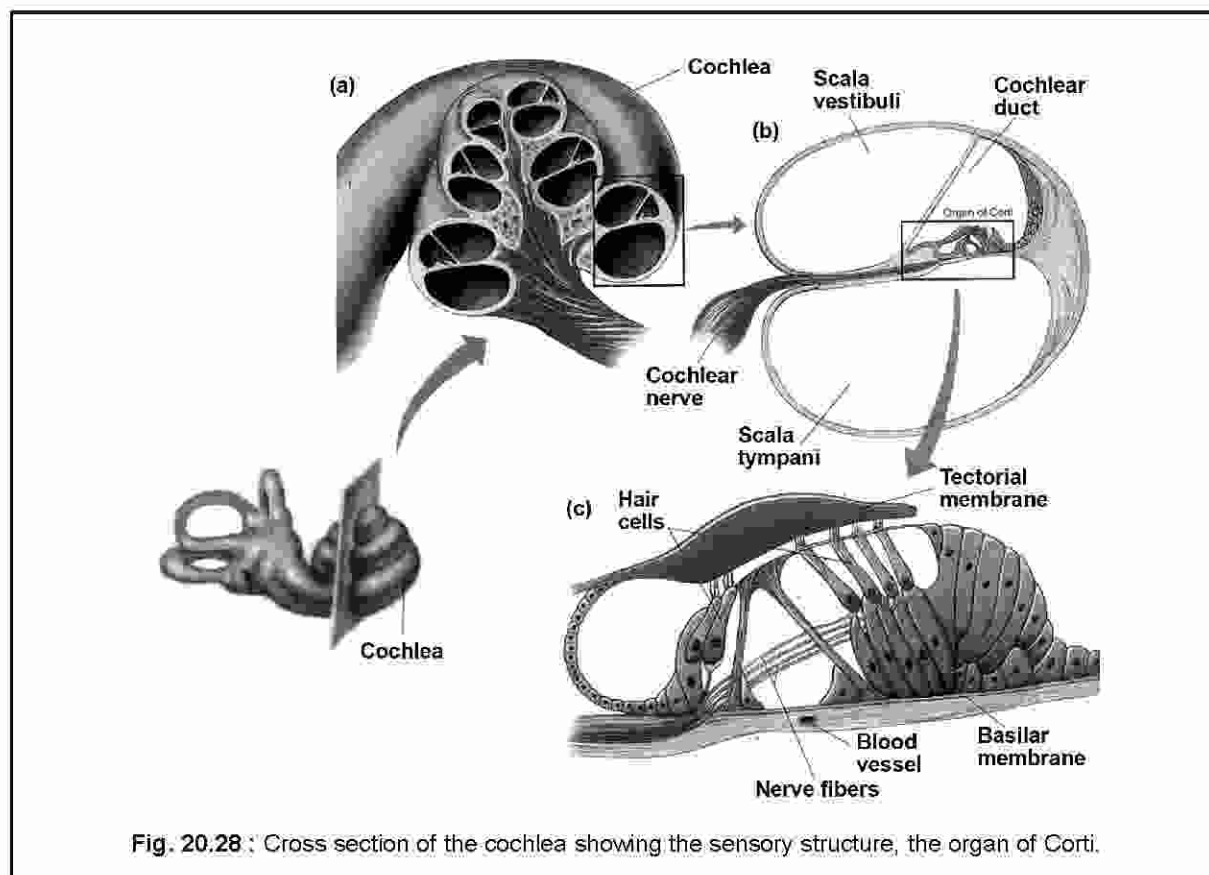

Fig. 20.28 : Cross section of the cochlea showing the sensory structure, the organ of Corti.

duct being one. Scala vestibuli is on the side of the cochlear duct and ends at the oval window, while scala tympani is below the cochlear duct and ends in a membrane covered round window. Both these compartments meet at the helicotrema. The cochlear duct is a continuation of the membranous labyrinth and hence contains endolymph, while scala vestibuli and scala tympani are filled with perilymph.

One side of the cochlear duct is formed by the basilar membrane to which is attached an organ of Corti or spiral organ. The organ of Corti is made up of single row of receptor cells, called the inner hair cells on the basilar membrane. In addition, there are multiple rows of outer hair cells. These cells have stereocilia projecting into the endolymph. The stereocilia of the outer hair cells are embedded in a gelatinous tectorial membrane.

**20.5.5.5. Mechanism of hearing (Fig. 20.29):** Sound waves of different intensities strike the tympanic membrane and create a vibration in it. Such vibrations are transmitted to the ear ossicles, present in the middle ear. Stapes, the third among the three is in contact with a membrane called the oval window. The vibrations are transferred to the perilymph of scala vestibuli. The pressure is then passed on to the perilymph of scala tympani through the helicotrema. The pressure in the perilymph causes the basilar membrane to vibrate. The consequence is the stimulation of the sensory hair cells, which rest on the basilar membrane. On stimulation, the hair cells release a transmitter substance, which brings about the depolarization of the nerve fiber membrane constituting the vestibulo-cochlear nerve (cranial

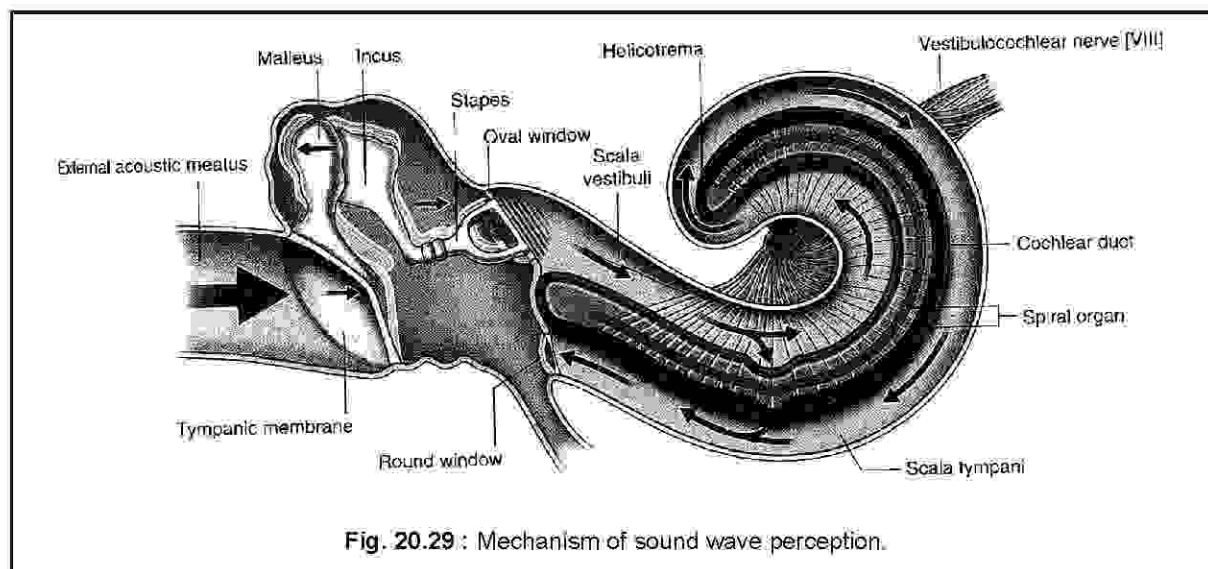

Fig. 20.29 : Mechanism of sound wave perception.

nerve VIII). The hair cells thus transform the pressure waves into receptor potentials.

#### 20.5.6. Sense of Vision :

There is a pair of eyes in human as the organs of vision. The eyes transduce electromagnetic waves of light into nerve impulses, which is perceived and interpreted by the brain as an image of an object. Each eye is spherically shaped and is situated in a groove of the frontal region of the skull, known as orbit. The eye is held in position by flexible eye ball muscles.

**20.5.6.1. Structure (Fig. 20.30):** The eye ball is covered by an outer layer of fibrous tunic, known as sclera. Sclera is avascular (without blood supply) connective tissue, which gives a spherical shape to the eye ball. At the anterior face, the sclera is transparent through which rays of light enter into the eye. This transparent part of the sclera is known as cornea. The middle layer is a highly vascular pigmented connective tissue, known as choroid. It supplies blood to the eye ball. The choroid separates off from the sclera at the anterior face, where it bears the name of iris. The iris has a circular aperture at its centre, known as pupil. The iris contains both longitudinal and radial muscles. Both muscles have opposing actions. The contraction of the longitudinal muscles dilates the pupil, while the contraction of the radial muscles constricts the pupil. This act is executed in response to the intensities of light entering into the eye. The posterior part of the iris is pigmented that gives the eye its characteristic colour.

- **Glaucoma :**

The aqueous humor is secreted by a vascular tissue of the body. It is drained into the venous system via the canal of Schlem. However, in some instances, the aqueous humor is formed faster than it is removed. If this situation prevails, the intra-ocular pressure exerted by the fluid increases creating a condition what is known as glaucoma. This may damage the nerve fibers of the eye and may result in complete loss of vision.

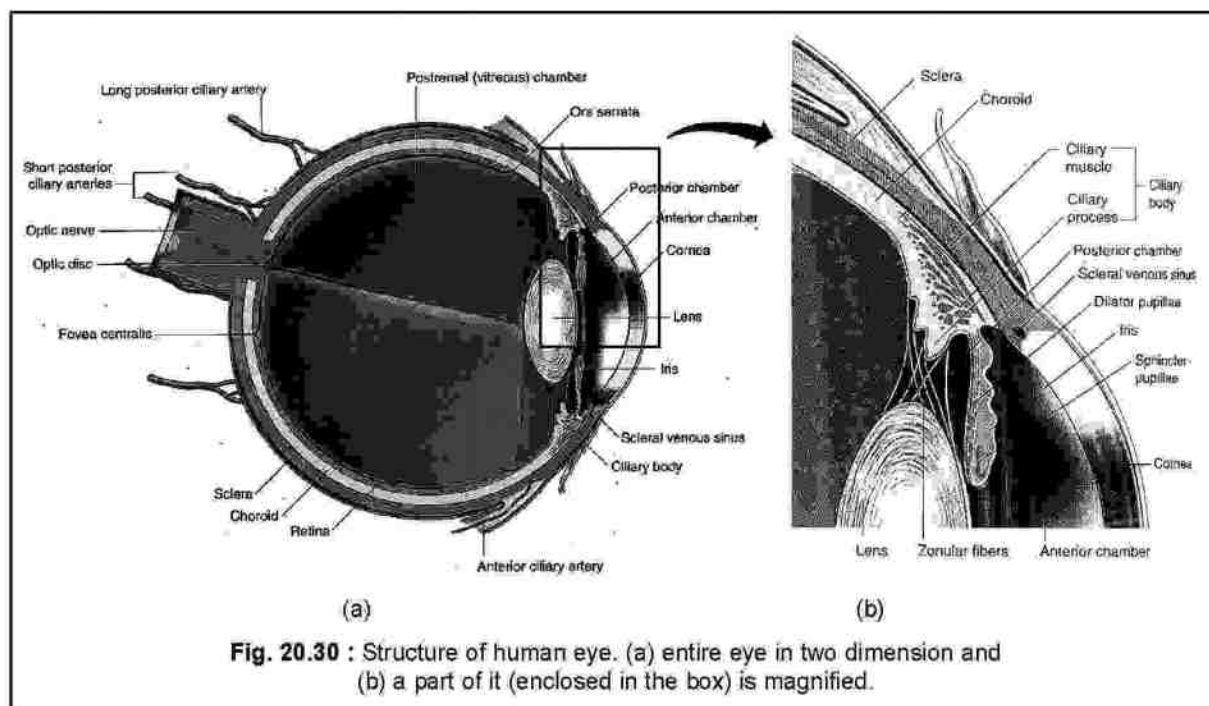

**Fig. 20.30** : Structure of human eye. (a) entire eye in two dimension and (b) a part of it (enclosed in the box) is magnified.

A biconvex lens is suspended from a muscular process called **ciliary body**, which connects the choroid and encircles the entire lens. **Zonular fibers** suspend the lens from the ciliary body. The zonular fibers together constitute the **suspensory ligament**. The space between the cornea and the iris is known as the **anterior chamber**, while the space between the iris and the ciliary body is the **posterior chamber**. Both the chambers are filled with a fluid known as **aqueous humor**. This fluid is secreted by a vascular tissue of the ciliary body and passes through the pupil into the anterior chamber. It nourishes the avascular lens and cornea. Aqueous humor is drained into a venous sinus known as **canal of Schlemm**, from where it returns to the venous blood. The chamber behind the lens is known as the **vitreous chamber** filled with a thick and viscous fluid, known as **vitreous humor**.

The vitreous chamber is lined by a sensory layer, known as **retina**. The retina contains two types of photoreceptor cells or neurons, the **rods** and **cones** in a single layer. Rods, which distinguish between intensities of light, contain a purple pigment called **rhodopsin**. Cones perceive and distinguish different colours. Human is **trichromatic** i.e there are three types of cone cells in the human retina, which perceive red, blue and green colours. Outer to this layer, there are two other layers of neurons, an inner layer of **bipolar neurons** and an outer layer of **ganglion cells**. The adjacent layers are connected by synapses. The fibers of the ganglion cells gather together at a point called the **optic disc**, where they exit the retina as the **optic nerve**. This region lacks the photoreceptors and hence is known as the **blind spot**. The optic disc is also the site of entry and exit of blood vessels. Another area of the retina is known as **fovea centralis** or **yellow spot**, where cones are most concentrated. The image is formed on fovea centralis, which gives clarity to vision.

- **Cataract:**

The eye lens changes its colour with age. The opacity increases and the vision is gradually impaired. This condition is known as cataract. The opaque lens is removed surgically and an artificial lens is implanted. Effective vision is restored although the power of accommodation is lost.

**20.5.6.2. Image Formation (Fig. 20.31) :** An image of an object is formed on the retina by obeying the fundamental principles of light refraction. The curvatures of the cornea and the lens are such that an inverted image of an object is formed on the retina. Secondly, the visual field i.e. the object that is projected on the retina is reversed in each eye. The cornea and lens focus the right part of the visual field on the left half of the retina of each eye and conversely, the left half of the visual field is focused on the right half of the retina of each eye. This is because of the crossing over of the optic nerves and formation of an **optic chiasma**, an X shaped structure.

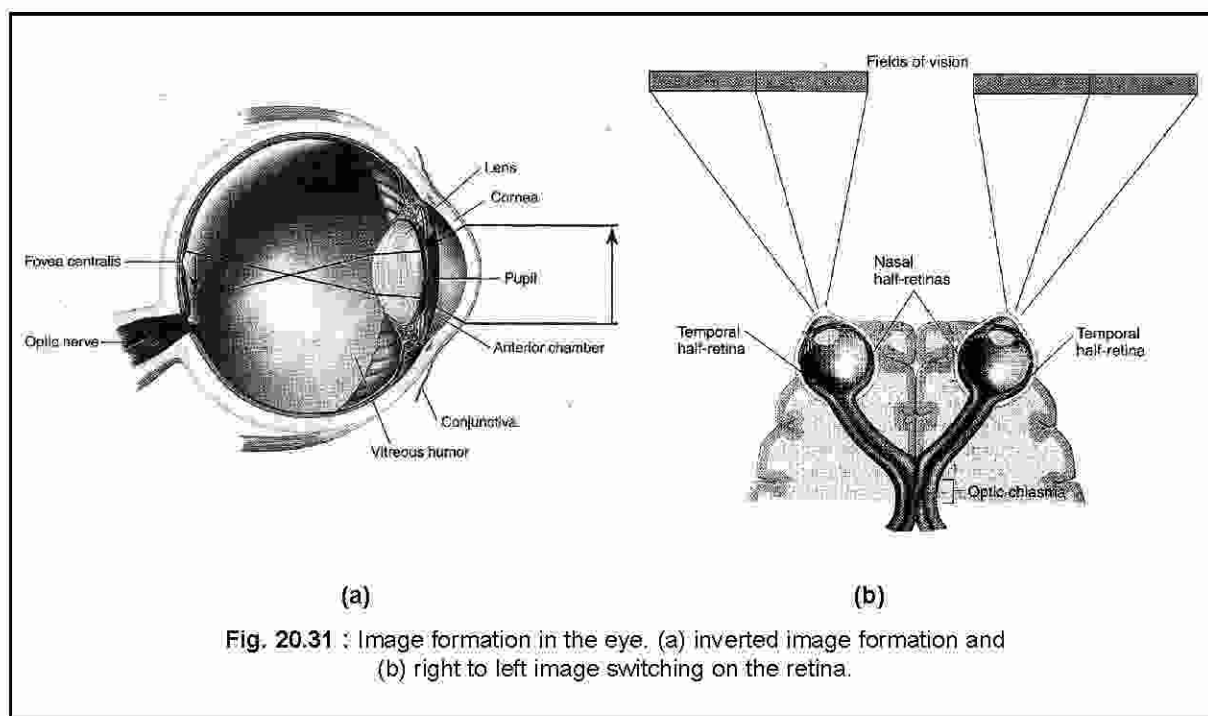

- **Accommodation and Loss of Accommodation (Presbyopia):**

The ability of the eyes to focus the image on the retina with the variation of the distance of the object from the cornea is known as accommodation. Accommodation is accompanied by the contraction and relaxation of two types of ciliary muscles. Accommodation ability is measured by a near point of vision test. The near point of vision is the minimum distance from the eyes from which the image of an object can be focused on the retina. This distance increases with age. Almost everyone over the age of 45 yrs is significantly affected. The loss of accommodation ability with age has been defined as presbyopia.

- **Impairments in normal vision:**

As long as the eyes are able to accommodate with the distance from the object, there is normal vision. Normal vision is termed as *emmetropia*. However, this property of accommodation is decreased with age and the eye ball changes its shape permanently due to some reason or other, the image can't be focused on the retina. Instead, the focus point is either in front or behind the eye ball. In such cases, the vision becomes impaired or abnormal. Two types of abnormal visions are classed: *hyperopia* (farsightedness) and *myopia* (nearsightedness). Secondly, if the curvatures of the cornea and the lens are uneven, an impairment known as *astigmatism* results.

- **Red Green Colourblindness:**

It is a recessive sexlinked disorder, in which either L (red) or M (green) cones are absent in the retina. These people are dichromates, since their retina has two types of functional cones. The absence of functional M cones, a condition called deuteranopia is the most common form of colourblindness. The absence of L cones (protanopia) is less common and the absence S (blue) cones (tritanopia) is least common. Photopsins, cone pigments are encoded by genes present on the X chromosome. Since men have one X chromosome, red-green colourblindness is far more common in males ( incidence of 8%) than in womwn (incidence of 0.5%).

---



**SAMPLE QUESTIONS****GROUP - A****(Objective-type Questions)****1. Choose the correct answer:**

- (i) The myelin sheath around a nerve fiber in the peripheral nervous system is formed by:
- (a) Oligodendrocytes (b) Microglial cells  
(c) Schwann cells (d) Astrocytes
- (ii) The somatic sensory neuron conducts nerve impulse:
- (a) From a somatic receptor to the central nervous system.  
(b) From central nervous system to the skeletal muscle.  
(c) From the central nervous system to the smooth muscle and or glands.  
(d) From a visceral receptor to the central nervous system.
- (iii) The cerebrospinal fluid is present:
- (a) In the subdural space only  
(b) In the subarachnoid space only  
(c) In the ventricles and central canal only.  
(d) Both (b) and (c)  
(e) Both (a) and (b)
- (iv) The brain stem consists of :
- (a) Diencephalon, midbrain and pons  
(b) Diencephalon, midbrain and medulla oblongata  
(c) Midbrain, cerebellum and medulla oblongata  
(d) Midbrain, pons and medulla oblongata.
- (v) Emotional states are regulated by:
- (a) Corpora quadrigemina (b) Limbic system  
(c) Basal nuclei (d) Corpus callosum
- (vi) Hypothalamus is a part of:
- (a) Telencephalon (b) Metencephalon  
(c) Diencephalon (d) Mesencephalon
- (vii) Memory is regulated by:
- (a) Hypothalamus (b) Hippocampus only  
(c) Amygdala only (d) Both (b) and (c)
- (viii) The superior colliculi of corpora quadrigemina are involved in:
- (a) Auditory reflexes (b) Visual reflexes  
(c) Releasing pituitary hormones (d) Relaying of cutaneous information
- (ix) In most people, the right side of the hemisphere controls the movements of:
- (a) The right side of the body primarily  
(b) The left side of the body primarily

- (c) Both the right and left sides of the body equally
- (d) Head and neck only
- (x) In control of emotion and motivation, the limbic system works together with:
  - (a) Pons
  - (b) Thalamus
  - (c) Hypothalamus
  - (d) Cerebellum
- (xi) Lateral geniculate nuclei relay:
  - (a) Auditory information
  - (b) Olfactory information
  - (c) Visual information
  - (d) Gustatory information
- (xii) Temperature regulation of the body is done by:
  - (a) Thalamus
  - (b) Cerebellum
  - (c) Hypothalamus
  - (d) Medulla oblongata
- (xiii) Respiratory and cardiovascular functions are controlled by:
  - (a) Medulla oblongata
  - (b) Cerebellum
  - (c) Diencephalon
  - (d) Telencephalon
- (xiv) Autonomic nervous system consists of nerves with:
  - (a) One neuron with one synapse
  - (b) Two neurons with two synapses
  - (c) One neuron with two synapses
  - (d) Two neurons with one synapse
- (xv) Parasympathetic ganglia are located
  - (a) in a chain parallel to the spinal cord
  - (b) In the dorsal roots of the spinal nerves
  - (c) Next to or within the organs innervated
  - (d) In the brain
- (xvi) The neurotransmitter of preganglionic sympathetic fiber is
  - (a) Norepinephrine
  - (b) Epinephrine
  - (c) Acetylcholine
  - (d) Dopamine
- (xvii) Depolarization is characterized by:
  - (a) Influx of sodium ions.
  - (b) Efflux of potassium ions
  - (c) Influx of potassium ions
  - (d) Efflux of sodium ions
- (xviii) Gustation is related to
  - (a) Sense of smell
  - (b) Sense of taste
  - (c) Sense of vision
  - (d) Sense of hearing
- (xix) Balance and equilibrium of the body is maintained by
  - (a) Semicircular canals only
  - (b) Saccule only
  - (c) Utricle only
  - (d) All the above
- (xx) The retina consists of
  - (a) Unipolar neurons
  - (b) Bipolar neurons
  - (c) Multipolar neurons
  - (d) Pseudounipolar neurons

**2. Express the following statements in one word:**

- (i) The singular long process of a multipolar neuron.
- (ii) The functional junction between two neurons.
- (iii) The nervous system constituted by cranial and spinal nerves.
- (iv) The cell that forms myelin sheaths around nerve fibers of the peripheral nervous system.
- (v) The neuron possessing one each of an axon and a dendron.
- (vi) The nerve fiber that carries neural information from the central nervous system to the receptors.
- (vii) A collective name for the connective tissue coverings of the brain and spinal cord.
- (viii) The fluid that is present in the subarachnoid space, ventricles and central canal.
- (ix) Metencephalon and myelencephalon together constitute a part of the brain.
- (x) Midbrain, pons and medulla oblongata together constitute a part of the brain.
- (xi) The fiber tract connecting the two cerebral hemispheres.
- (xii) Corpus striatum is a predominant part of the subcortical nuclei. Name the nuclei.
- (xiii) The system and hypothalamus that regulate the emotional states of a person. Name the system.
- (xiv) The vascular tissue that secretes the cerebrospinal fluid.
- (xv) The thalamic nuclei that relay visual information to the occipital lobe.
- (xvi) The inferior colliculi are the relay centres of a neural information. Name the neural information.
- (xvii) The regulatory centres of the respiratory system and cardiovascular system lie in a part of the brain. Name it.
- (xviii) Coordination of movements is executed by a part of the brain. Name it.
- (xix) The communication between the third and fourth ventricles of the brain.
- (xx) A fine connective tissue filament attached to the conus medullaris of the spinal cord.
- (xxi) The chemical substance that is secreted into the synaptic cleft by the presynaptic neuron.
- (xxii) The unconscious motor response to a sensory stimulus.
- (xxiii) The influx of sodium ions changes the polarity of distribution of electrical charges across the membrane of a nerve fiber. Name the process.
- (xxiv) The conduction of nerve impulse along a myelinated nerve fiber.
- (xxv) Equilibrium or orientation with respect to gravity is controlled by an apparatus.
- (xxvi) The part of the membranous labyrinth connected with hearing.
- (xxvii) The tubular connection between the middle ear and pharynx.
- (xxviii) The part of the retina that doesn't contain any photoreceptor cell.
- (xxix) The part of the retina, where an image is formed with highest resolution.
- (xxx) Photoreceptor cells of the retina that perceive colour.

- (xxx) The fluid present in the membranous labyrinth.  
 (xxxi) The fluid present in the bony labyrinth.

**3. Correct the sentences, if incorrect, without changing the words underlined:**

- (i) Somatic motor neurons conduct nerve impulse from the sensory receptors to the central nervous system.
- (ii) The central nervous system is constituted by the cranial and spinal nerves.
- (iii) The autonomic motor neurons with their control centres constitute the somatic division of the peripheral nervous system.
- (iv) The functional junction between a neuron and an effector cell is known as a synapse.
- (v) In human, all synapses are electrical.
- (vi) The sequence of the meninges from outer to inner is piamater, arachnoid mater and duramater.
- (vii) Cerebrospinal fluid is secreted by the meninges.
- (viii) The functional junction between the two cerebral himispheres is known as corpus striatum.
- (ix) Pineal gland arises from a part of the diencephalon, known as hypothalamus.
- (x) The mass of cell bodies and axons running through the brain stem is known as corpus callosum.
- (xi) Superior colliculi relay auditory information to the occipital lobe of the cerebrum.
- (xii) Medulla oblongata coordinates movement and equilibrium.
- (xiii) Foramen of Monro connects the third ventricle with the fourth ventricle.
- (xiv) In the spinal cord, the outer part is made by white matter, while the inner by gray matter.
- (xv) The gray matter consists of medullated nerve fibers.
- (xvi) The somatic nervous system is constituted by nerves with two types of neurons and a synapse in a ganglion.
- (xvii) Acetylcholine is secreted as the neurotransmitter between pre and postganglionic fibers in both the sympathetic and parasympathetic divisions.
- (xviii) In somatic motor reflex, the motor transmission is executed by one each of preganglionic and postganglionic neurons with a synapse in a sympathetic ganglion.
- (xix) Efflux of sodium ions and influx of potassium ions during nerve impulse conduction have been characterized as repolarization.
- (xx) The correct order of the ear ossicles from outer to inner is incus, malleus and stapes.
- (xxi) Stapes is in contact with a round window.

**4. Fill in the blanks with appropriate words:**

- (i) The central nervous system is constituted by \_\_\_\_ and \_\_\_\_.
- (ii) The structural and functional unit of the nervous system is known as \_\_\_\_.

- (iii) The basophilic granular material present in the neuron cytoplasm is known as \_\_\_\_\_.
- (iv) The axons of some neurons are encapsulated by an insulating lipid material, known as \_\_\_\_\_.
- (v) The myelin sheaths around the nerve fibers in the central nervous system are formed by \_\_\_\_\_ cells.
- (vi) The efferent motor neurons that conduct impulse from the central nervous system to the visceral effectors are known as \_\_\_\_\_.
- (vii) The functional junction between two neurons is known as \_\_\_\_\_.
- (viii) The junction between a neuron and an effector is known as \_\_\_\_\_.
- (ix) The impulse transmission across a synapse is carried out by a chemical substance, known as a \_\_\_\_\_.
- (x) The middle meninx of the brain is known as \_\_\_\_\_.
- (xi) The brain is covered by a delicate connective tissue layer called \_\_\_\_\_.
- (xii) The dense fibrous connective tissue layer that forms a lining of the cranium is known as \_\_\_\_\_.
- (xiii) The subarachnoid space is filled with a fluid called \_\_\_\_\_.
- (xiv) The cerebrospinal fluid is secreted by \_\_\_\_\_.
- (xv) The brain stem is constituted by midbrain, \_\_\_\_\_ and medulla oblongata.
- (xvi) Two cerebral hemispheres are connected by a fibrous tract, known as \_\_\_\_\_.
- (xvii) The cerebrum surface is marked by the presence of elevations and depressions, known as \_\_\_\_\_ and \_\_\_\_\_, respectively.
- (xviii) The mass of cell bodies and axons that run through the brain stem constitutes \_\_\_\_\_.
- (xix) Corpora striata are integral parts of the predominant subcortical nuclei called \_\_\_\_\_ nuclei or ganglia.
- (xx) Lateral geniculate nucleus relays \_\_\_\_\_ information to \_\_\_\_\_ lobe of the cerebrum.
- (xxi) Medial geniculate nucleus relays \_\_\_\_\_ information to \_\_\_\_\_ lobe of the cerebrum.
- (xxii) Superior colliculi and inferior colliculi are concerned with \_\_\_\_\_ and \_\_\_\_\_ functions, respectively.
- (xxiii) The degeneration in the caudate nucleus causes a dominant genetic disorder, known as \_\_\_\_\_.
- (xxiv) The respiratory centres are situated in \_\_\_\_\_ and \_\_\_\_\_ of the brain.
- (xxv) Coordination in speech and movement are controlled by \_\_\_\_\_ of the brain.
- (xxvi) Two lateral ventricles communicate with each other and with the third ventricle through \_\_\_\_\_.
- (xxvii) The ventricular communication between the third and fourth ventricles is known as \_\_\_\_\_.
- (xxviii) There are \_\_\_\_\_ pairs of cranial and \_\_\_\_\_ pairs of spinal nerves in human.
- (xxix) The bunch of spinal nerves at the posterior end of the spinal cord, resembling a horse tail is known as \_\_\_\_\_.

- (xxx) An autonomic nerve consists of \_\_\_\_\_ number of neurons and \_\_\_\_\_ number of synapses.
- (xxxii) The nerve fibers of the afferent (sensory) division convey information from the receptors to the central nervous system. Such fibers are classed as \_\_\_\_\_ neurons in respect of the number of processes.
- (xxxiii) Two neurons of an autonomic nerve fiber are termed as \_\_\_\_\_ and \_\_\_\_\_.
- (xxxiv) The autonomic nervous system consists of two divisions, namely \_\_\_\_\_ and \_\_\_\_\_.
- (xxxv) The conduction of a nerve impulse along a myelinated nerve fiber is known as \_\_\_\_\_ conduction.
- (xxxvi) The vestibular apparatus is constituted by the utricle, the saccule and \_\_\_\_\_.
- (xxxvii) Changes in linear acceleration i.e. in velocity are regulated by \_\_\_\_\_ and \_\_\_\_\_, while changes in angular velocity are regulated by \_\_\_\_\_.
- (xxxviii) The spirally coiled structure attached to the membranous labyrinth, which serves as the organ of hearing is known as \_\_\_\_\_.
- (xxxix) The sensory part of the cochlea is known as \_\_\_\_\_.
- (xl) The innermost layer of the eye ball that contains the sensory cells is known as \_\_\_\_\_.
- (xi) The visual sensory cells are of two types, namely \_\_\_\_\_ and \_\_\_\_\_.

### GROUP - B

#### (Short Answer-type Questions)

1. Answer the following within three sentences each:

- (i) What is the function of myelin sheath?
- (ii) Why are gray matter and white matter named so?
- (iii) Is there any difference between an efferent neuron and motor neuron?
- (iv) What is the role of limbic system?
- (v) Which parts of the brain regulate memory?
- (vi) What is a chemical synapse?
- (vii) Cerebrospinal fluid is being secreted continuously by the choroid plexus. How is this volume kept constant?
- (viii) What do you understand by cerebral lateralization?
- (ix) How is the day night cycle regulated by melatonin?
- (x) What is a spinal nerve? Where does it originate from?
- (xi) Describe a pseudounipolar neuron.
- (xii) What are preganglionic and postganglionic nerve fibers? These are characteristic features of which section of the nervous system?
- (xiii) What is a sympathetic trunk? Describe about what it is made up of .
- (xiv) What is a reflex arch?
- (xv) What is an action potential? How does it help in the conduction of the nerve impulse?
- (xvi) What is synaptic transmission?

- (xvii) Are there different regions in the tongue for different tastes? Yes or No. Justify.
- (xviii) What is a vestibular apparatus? How does it help maintain balance and equilibrium with respect to gravity?
- (xix) How does the cochlea perceive the auditory stimulus?
- (xx) What is the role of fovea centralis in the image formation by the eye.

**2. Differentiate between two words in each of the pairs of words:**

- (i) Axon and Dendron
- (ii) Schwann cell and Oligodendrocyte
- (iii) Somatic nervous system and Visceral nervous system
- (iv) Bipolar and Multipolar neurons
- (v) Afferent neurons and Efferent neurons
- (vi) Chemical synapse and Electrical synapse
- (vii) Corpus callosum and Corpus striatum
- (viii) Medullated and Nonmedullated nerve fibers
- (ix) Sympathetic system and Parasympathetic system
- (x) Somatic motor reflex and Autonomic motor reflex
- (xi) Depolarization and Repolarization
- (xii) Aqueous humor and Vitreous humor
- (xiii) Endolymph and Perilymph
- (xiv) Rod cells and Cone cells

**GROUP - C**

**(Long Answer-type Questions)**

1. Describe the structure of human brain and enumerate important functions of each part of it.
2. Give an account of the mechanism of generation and propagation of a nerve impulse.

OR

Describe the mechanism of conduction of nerve impulse.



The body's control and coordination are maintained by two systems. One, being the nervous system, the other is the endocrine system. These two systems act as body's communication systems. The systems integrate among various systems and enable the body to work as a unified whole. Alternately speaking, the body functions in a state of internal homeostasis and adapts itself to the ever changing external physical environment as and when necessary. Proper functioning of these two systems guarantees the continued existence of the individual in the ever changing environment. If things go wrong in these systems, the body breaks apart. In the preceding chapter we have described about the structure and the working mechanism of the nervous system. In the present chapter we shall acquaint you with the endocrine glands, the hormones they secrete and their physiological functions.

The word endocrine is derived from two Greek roots; one being *endon*, meaning within and the other *krinein*, meaning to secrete. Simplifying the meaning we refer it to as internal secretion. We understand secretion. What is then internal? Any secretion that is directly discharged into the blood is an internal secretion. Explaining it in another way, internal secretions are secreted from ductless glands, which are discharged into the blood. These ductless glands have been termed as endocrine glands and their secretions as hormones. A hormone, following its secretion, acts on a target cell, tissue or organ and brings about an appropriate response. A hormone is a biologically active compound, which acts on its target in a specific manner even at its lowest concentration.

William Bayliss and Earnst Starling (1902) demonstrated that an active substance secreted from the mucosa of the small intestine stimulated the release of pancreatic juice from the pancreas. This active substance was named as secretin. Earnst Starling (1905) used the word hormone for secretin. Thereafter, research and investigation in this area have gone so far as establishing the study of endocrine glands, their secretions, and their physiological roles as a separate area of study, known as endocrinology.

There are two principal types of glands in the body: 1. Exocrine and 2. Endocrine. Exocrine glands are glands, which release their secretions into lumens through ducts (e.g., salivary glands, gastric glands, liver, exocrine pancreas, etc.). Endocrine glands, conversely are without ducts. These release their secretions directly into the blood. Refer to Table 21.1 for a complete list of endocrine glands of the body.

### **21.1. CLASSES OF HORMONES :**

Hormones secreted from the endocrine glands vary widely in their chemical structures. However, all hormones are placed under four comprehensive classes: 1. amine hormones; 2. glycoprotein hormones; 3. polypeptide and protein hormones; and 4. steroid hormones.



1. **Amine Hormones:** These hormones are derived from amino acids tyrosine and tryptophan. These include the hormones secreted by the thyroid, adrenal medulla and pineal glands.
2. **Glycoprotein Hormones:** A glycoprotein hormone molecule consists of a long polypeptide with more than 100 amino acids. Carbohydrate residues are found to be attached to the polypeptide. These include thyroid stimulating hormone (TSH), follicle stimulating hormone (FSH) and lutenizing hormone (LH).

- **Pheromones:**

Pheromones are substances produced by one animal, that act at a distance on another animal to produce hormonal, behavioural and other physiological changes. These substances are prevalently secreted by invertebrates for effective communication among themselves. Two female roommates have a tendency to synchronize their menstrual cycles i.e. cycles tend to occur almost at the same time. This effect has been termed as dormitory effect. It has been established that an armpit odorant is responsible for this synchronization. This synchronization will not occur in another roommate, whose nasal apertures are plugged with cotton. This suggests that the chemical agent, that is known as a pheromone, acts through the olfactory sense. Pheromones are important regulatory molecules in the urine, vaginal fluid and other secretions in most mammals, which regulate the reproductive cycles and behaviour.

3. **Polypeptide and Protein Hormones:** Polypeptide hormones generally contain less than 100 amino acids. A majority of hormones are polypeptide hormones. In a protein hormone, however, two or more polypeptides interact by forming covalent bonds. Insulin by far is the best example from this class, which contains two polypeptides interacting with each other by two disulfide bonds.
4. **Steroid Hormones:** These hormones are derived from cholesterol, a class of lipids. Hormones secreted from adrenal cortex, testis and ovary are steroids. Some hormones of the placenta are also steroids.

- **Anabolic Steroids:**

Steroid hormones, as such are protein anabolic hormones i.e. they promote protein synthesis and hence promote growth of the body. These steroids are, therefore, termed as anabolic steroids. Keeping this in view, some synthetic steroid hormones, particularly androgens have been synthesized for therapeutic purpose. These are prescribed by a registered medical practitioner under exigency only. However, weight lifters, sprinters, body builders and other athletes misuse such steroids with a hope to make their body more competitive to others in athletic meets. These steroids in addition to protein synthesis promotion, induce a number of undesirable side effects. In addition, administration of such synthetic androgens negatively feeds back the gonadotropin secretion from the anterior pituitary. Looking at these mass misuse, international and national athletic organizations have imposed a ban on the use of such anabolic steroids and have screening procedures. A penal code has been prescribed for athletes, who have been found guilty of misusing anabolic steroids.

## 21.2. ENDOCRINE GLANDS :

Endocrine glands are distributed all throughout the body. There are many endocrine gland, namely, pituitary, thyroid, parathyroid, adrenal, which have exclusive endocrine functions. Other glands, in addition to the execution of their physiological roles, have endocrine functions. Among such glands are hypothalamus, pancreas, testis, ovary, gastro-intestinal tract, placenta, pineal, thymus, liver, kidney and many more. A comprehensive account of the endocrine glands in respect of their locations and physiological roles are presented in Fig. 21.1.

### 21.2.1. PITUITARY :

**Pituitary**, also known as **hypophysis** lies in a concavity, known as **sella turcica** of the **sphenoid bone** of the skull. It connects to the hypothalamus that constitutes the floor of the diencephalon by a stalk, known as **infundibulum**. Pituitary is made by the apposition of two parts: **1. posterior pituitary** or **neurohypophysis** and **2. anterior pituitary** or **adenohypophysis** (Fig. 21.2). Although these two parts originate from ectoderm, their embryological origins are different. The neurohypophysis originates from the floor of the diencephalon i.e. it is neural in origin, while adenohypophysis originates from the pharyngeal ectoderm. Following their origin and formation, they associate forming a complete pituitary gland.

**21.2.1.1. Anterior Pituitary(Adenohypophysis):** The anterior pituitary of adult human further consists of two distinct parts: (i) **pars distalis**; and (ii) **pars tuberalis** (Fig. 21.2). Pars distalis is the bulk part of adenohypophysis and secretes all tropic hormones. Pars tuberalis is a thin extension of tissue surrounding the infundibulum. A third lobe of adenohypophysis namely, **pars intermedia** is present between the two existing lobes in the human fetus. However, in due course of development, it merges with **pars distalis** i.e. it is absent in adult human pituitary.

- **Prohormones and Prehormones:**

Hormone molecules that regulate metabolism are often synthesized as inactive molecules or precursors, which undergo modifications and turn into active hormones. These precursors are termed as pre- pro-hormones. In the first step, it undergoes a cleavage to form a pre-hormone, while in the second, the pre-hormone turns into an active hormone. For example, insulin is synthesized by the beta cells as a pre-pro-insulin, which by cleavage turns into pro-insulin. The pro-insulin, in turn undergoes a modification to turn into active insulin. The term pre-hormone is sometimes used to indicate the precursors of active hormones. Some such activations are indicated below:

Gland	Pre-hormone	Active Hormone
Skin	Vitamin D <sub>3</sub>	1,25 Dihydroxyvitamin D <sub>3</sub>
Testis	Testosterone	Dihydrotestosterone
Thyroid	Thyroxine (T <sub>4</sub> )	Triiodothyronine (T <sub>3</sub> )

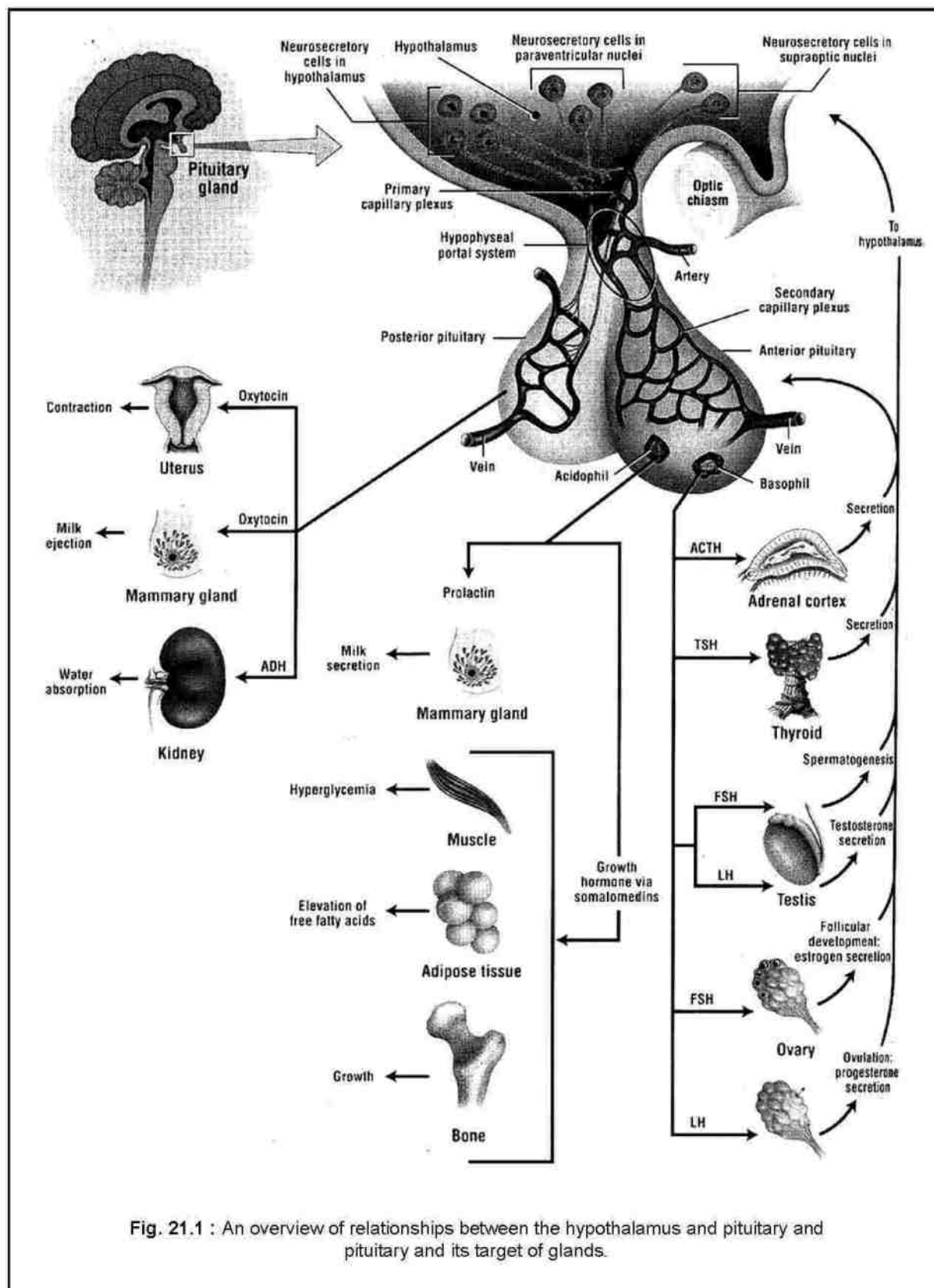
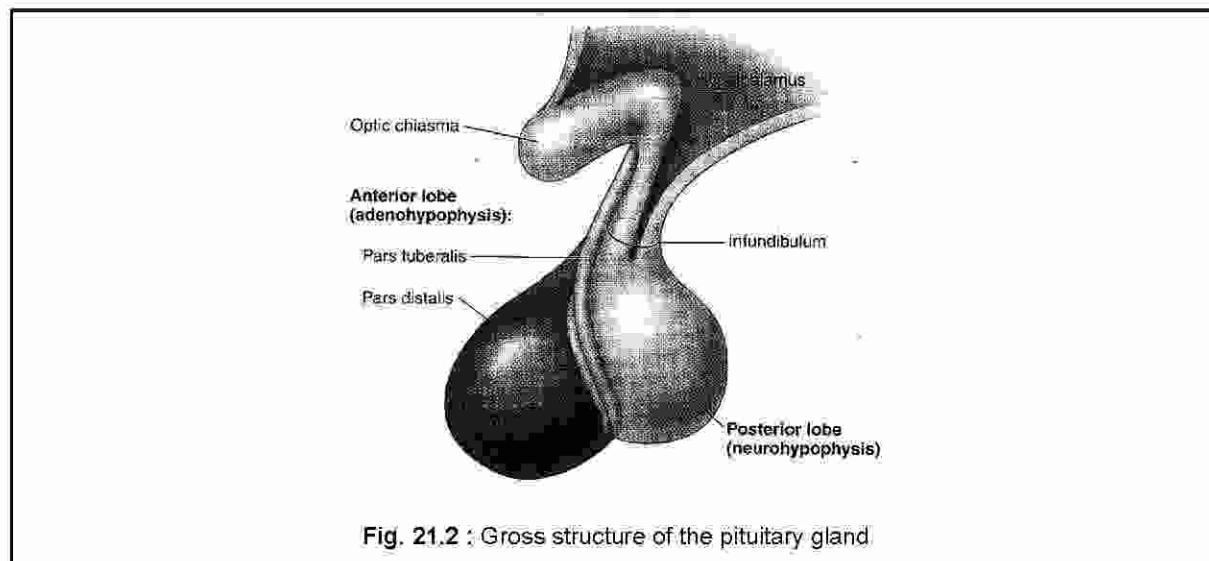

Fig. 21.1 : An overview of relationships between the hypothalamus and pituitary and pituitary and its target of glands.



Histologically, pars distalis contains two primary types of cells based on their staining properties: **chromophobes** and **chromophils**. The chromophils are subdivided into **acidophils (alpha cells)** and **basophils (beta cells)**. Acidophils secrete growth hormone or somatotrophic hormone (GH / STH) and prolactin (PRL), while basophils secrete follicle stimulating hormone (FSH), luteinizing hormone (LH), thyroid stimulating hormone (TSH) and **adrenocorticotrophic hormone (ACTH)**.

**21.2.1.2. Blood Supply to the Pituitary:** While studying the structure and functions of the pituitary gland, a study about its blood supply is of paramount importance because it forms the basis of a very fine functional relationship among the three elements namely, the hypothalamus, the neurohypophysis and the adenohypophysis.

There is no neural connection between the anterior and posterior pituitary elements. Connection is established only through the bloodvascular system. **Superior hypophysial arteries** from the internal carotid artery supply blood to pars tuberalis, median eminence and infundibulum. These arteries break up into capillaries which form a plexus in the median eminence at the base of the hypothalamus, known as the **primary capillary plexus**. The blood from the primary plexus is drained by venules, which join together and form a **hypothalamo-hypophysial portal vein**, which enters into the anterior pituitary and breaks up into another capillary plexus, known as the **secondary capillary plexus (Fig. 21.4)**.

**21.2.1.3. Hormones of Anterior Pituitary:** The hormones of the anterior pituitary were identified as **trophic hormones** because they were believed to nourish the cells of the target organ. However, when this correlation was proved to be wrong, **trophic** was shortened to **tropic**, meaning attracted to. As many as seven hormones are known to be secreted from the anterior pituitary. A brief description about each one's physiological role is presented hereunder.

1. **Growth Hormone (GH) or Somatotropic Hormone (STH) or Somatotropin:**
  - Growth hormone is a **protein anabolic hormone** i.e. it stimulates amino acid movement into muscle cells and **promotes protein synthesis**. Synthesis and accumulation of proteins accounts for a general growth of the body.
  - It induces **hyperglycemia** i.e. it increases the blood sugar level by **glycogenolysis** (breakdown of glycogen) in liver cells. This effect is known as the **diabetogenic effect**.
  - It acts on adipose tissue and releases free fatty acids into the blood.
  - It acts on liver cells and induces the synthesis of a class of polypeptides known as **somatomedins**. One of these somatomedins, known as **insulin-like growth factor I (IGF I)** is known to promote growth of long bones by acting on the epiphyseal cartilages.
2. **Prolactin (PRL) or Lactogenic Hormone, Luteotropic Hormone (LTH) :**
  - It promotes mammary gland development and induces **milk formation (lactation)** in females following the birth of a baby.
  - It promotes general growth like that of the growth hormone.
  - It induces **hyperglycemia**.
  - It increases fat deposition.
  - It also induces the growth of male sex accessory organs
3. **Thyroid Stimulating Hormone (TSH) or Thyrotropin:**
  - It acts on the thyroid gland as its target gland and promotes the secretion of **triiodothyronine (T3) and thyroxine (T4)**.
4. **Adrenocorticotropic Hormone (ACTH) or Corticotropin:**
  - Its target of action is adrenal cortex. It stimulates the zona fasciculata and perhaps zona reticularis of the cortex to secrete glucocorticoids (Cortisol).
5. **Follicle Stimulating Hormone (FSH) or Folliculotropin:**
  - In the male, it acts on the **seminiferous tubules** and promotes the **spermatogenesis** process.
  - It acts on the sertoli cells of the seminiferous tubules and induces the synthesis of **androgen binding proteins (ABP)**.
  - In the female, it acts on the **primary ovarian follicles** and promotes their growth.
6. **Lutenizing Hormone (LH) or Interstitial Cell Stimulating Hormone (ICSH):**
  - In the male, it stimulates the **interstitial cells** of the testis to secrete **androgens**.
  - In the female, it is responsible for the final maturation of the **ovarian follicles**.
  - It stimulates ovulation, formation of **corpus luteum** and secretion of **progesterone** from corpus luteum.

### 7. $\beta$ - lipotropin ( $\beta$ - LPH):

- It is a polypeptide of the anterior pituitary, which is not directly secreted by it. Instead, a large polypeptide, known as **proopiomelanocortin (POMC)** is secreted by the cells, believed to secrete ACTH.
- It is then cleaved by a suitable enzyme producing ACTH and  $\beta$  - LPH.  $\beta$  - LPH is cleaved to form three polypeptides, namely **endorphin**, **enkephalin** and **MSH** (melanocyte stimulating hormone).
- $\beta$  MSH doesn't have any apparent role in adult human nor is it secreted from the anterior pituitary.
- Endorphin and enkephalin are believed to act as body's **natural analgesics** i.e. **endogenous pain relieving molecules**.

**21.2.1.4. Hormones of Posterior Pituitary:** Posterior pituitary secretes two polypeptide hormones, namely **oxytocin** or **pitocin** and **vasopressin** or **antidiuretic hormone (ADH)**. These two hormones are considered as neurohormones, since these are synthesized by **neurosecretory cells** in the hypothalamus. As mentioned earlier that neurosecretory cells are specialized neurons of the hypothalamus, which have acquired the function of secretion. There are two such nuclei (clusters of neuron cell bodies), named as **supraoptic** and **paraventricular nuclei** in the hypothalamus (Fig. 21.3). The long axons of these neurosecretory cells descend down the infundibulum to the posterior pituitary and terminate in a capillary plexus. Note that there are two types of neurosecretory cells in the hypothalamus. One group, having relatively shorter axons terminate in the primary capillary plexus in the median eminence, discharging the releasing and release inhibiting hormones. The other group, having long axons, terminate in the capillary plexus in the posterior pituitary. These cells release oxytocin and vasopressin.

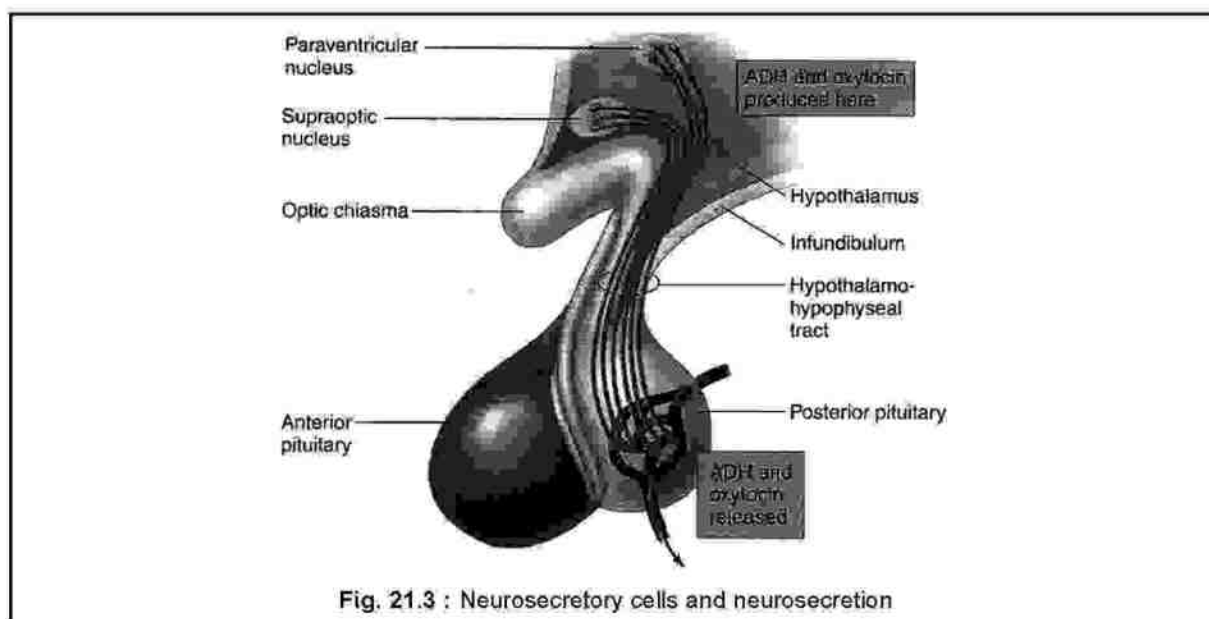

Fig. 21.3 : Neurosecretory cells and neurosecretion

### 1. Oxytocin (Pitocin):

- In the female, oxytocin stimulates the contraction of the uterus to facilitate parturition (child birth).
- It stimulates the contraction of the mammary gland alveoli and ducts, which results in milk ejection in the lactating mother. However, the oxytocin is released in response to the suckling of the nipple by the baby.
- In the male, it is believed to facilitate the ejaculation of semen.

### 2. Vasopressin [Antidiuretic Hormone (ADH)]:

- It acts on the proximal renal tubule and promotes the absorption of water from the glomerular filtrate.
- Its deficiency causes a disease, known as **diabetes incipidus** i.e. there is a loss of water by frequent urination of dilute urine.

**21.2.1.5. Hypothalamic Control of Anterior Pituitary Functions :** Recall that there is no neural or any type of communication between the posterior pituitary and anterior pituitary other than vascular. The only communication is via the blood vascular system. Investigations have proved that the functioning of the anterior pituitary is under the regulation of the hypothalamus via the bloodvascular system. Some neurons in the hypothalamus work together in regulating the functions of the anterior pituitary. Their cell bodies are present in groups, constituting nuclei. These neurons have acquired secretory functions and hence are known as **neurosecretory cells**. These cells secrete a number of releasing and release-inhibiting hormones into the primary capillary plexus, known to stimulate or inhibit specific cells of the adenohypophysis to secrete or inhibit the release of tropic hormones.

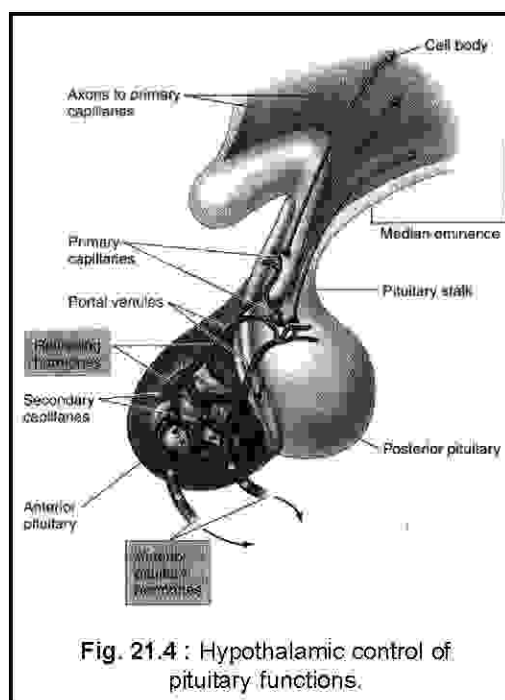

Fig. 21.4 : Hypothalamic control of pituitary functions.

Releasing hormones stimulate and augment the secretion of the corresponding tropic hormone, while release-inhibiting hormone inhibits the release of the said tropic hormone. These hormones reach the anterior pituitary only via the **hypothalamohypophysial portal vein**. Thus, the pituitary gland is under the regulation of the hypothalamus. The age old held idea that pituitary gland is the master gland becomes obsolete.

**Releasing and Release-Inhibiting Hormones:** The hypothalamus exercises its control over the anterior pituitary through the mediation of some releasing and release-inhibiting hormones and other chemical agents. A summary of this is presented below.

### Releasing and Release-inhibiting Hormones

1. Thyrotropin releasing hormone (TRH)
2. Growth hormone releasing hormone (GHRH)
3. Growth hormone release-inhibiting hormone (GIH)  
[also known as somatostatin (SST)]
4. Gonadotropin releasing hormone (GnRH)
5. Corticotropin releasing hormone (CRH)
6. Prolactin release-inhibiting hormone (PIH)  
(also known as dopamine)

### Effects

- Stimulates the secretion of TSH and PRL
- Stimulates secretion of GH
- Inhibits the secretion of GH and TSH
- Stimulates the secretion of FSH and LH.
- Stimulates secretion of ACTH
- Inhibits secretion of PRL

The entire story is summarized in the Fig. 21.5.

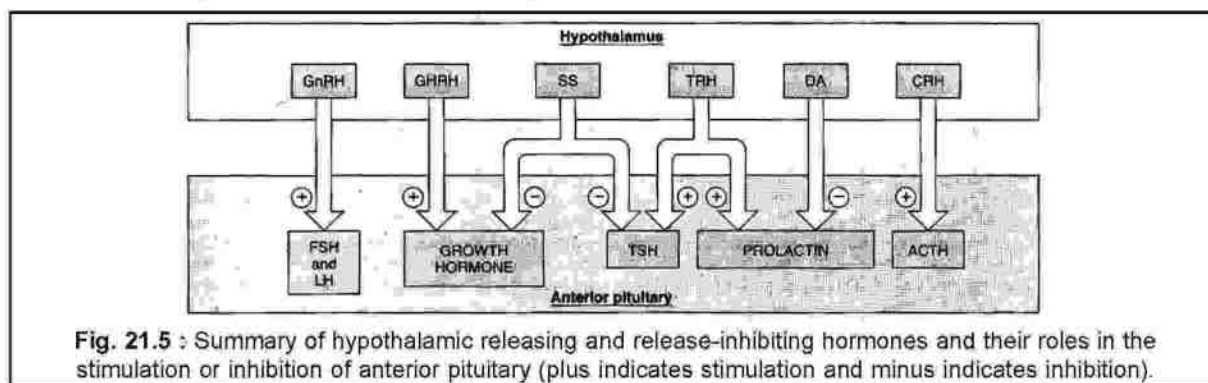

The flowchart shows the Hypothalamus secreting Thyrotropin-releasing hormone (TRH), which stimulates the Anterior pituitary to secrete Thyroid-stimulating hormone (TSH). TSH stimulates the Thyroid gland to produce Thyroxine. Thyroxine leads to 'Growth of thyroid'. A dashed arrow with a minus sign (-) points from Thyroxine back to the Anterior pituitary, labeled 'inhibits responsiveness (TRH)', indicating negative feedback.

● **Feedback Control:**

Many target glands are under the regulation of anterior pituitary tropic hormones and the anterior pituitary secretions in turn are under the regulation of the hypothalamus. There is a delicate hypothalamus-anterior pituitary-target gland regulation axis. Under ideal conditions, all these glands secrete precise quantity of hormones so that there is a physiological state of equilibrium in the body. However, under some abnormal situations, the target glands secrete more or less hormones than normal. This would destabilize the state of equilibrium. But, nevertheless, there is a feed back control mechanism by which any excess or deficient quantity of a particular target gland hormone exerts an appropriate influence on the anterior pituitary so as to secrete a precise quantity of a tropic hormone in order to bring the target gland hormone concentration back to normal. These control mechanisms are known as feedback control mechanisms. There are two types of feed back mechanisms: negative and positive.

Any excess of a target gland hormone negatively feeds back the anterior pituitary to secrete less tropic hormone so as to adjust the secretion of the target gland hormone. In positive feed back mechanism, the reverse series of actions take place.

Secretions of tropic hormones like ACTH, TSH, FSH and LH are controlled by negative feedback mechanisms. LH exhibits a positive feedback regulation mechanism.

**Negative Feedback of Anterior Pituitary by Thyroid Hormones**



### 21.2.2. THYROID GLAND :

There is a single thyroid gland, situated in the neck inferior to the larynx. It consists of **right and left lobes** connected by an **isthmus (Fig. 21.6)**. The thyroid tissue is made up of numerous spherical thyroid follicles embedded in a mass of extracellular material made up of reticular fibers and a rich network of blood capillaries. . These follicles are the structural and functional units of the thyroid gland. A follicle is lined by a single layer of cuboidal epithelium (Fig. 21.7). The follicle cells synthesize and release their product into the lumen of the follicle.

The lumen of the follicles is filled with a gelatinous substance called **colloid**. The colloid contains an **iodinated glycoprotein, thyroglobulin**. Thyroglobulin is the inactive storage form of the thyroid hormones [triiodothyronine ( $T_3$ ) and thyroxine ( $T_4$ )]. Thyroxine ( $T_4$ ) is not the active form of the hormone. It is converted to triiodothyronine ( $T_3$ ) inside the target cells. Therefore,  $T_3$  is the potent form of the thyroid hormone. In addition to the follicular cells, the thyroid tissue also contains pale staining **parafollicular cells**. These cells are arranged peripheral to the follicles. These cells are the source of **calcitonin**.

#### 21.2.2.1. Functions of Thyroid Hormones:

Thyroid hormones are synthesized by the follicular cells from the amino acid tyrosine and iodide radical collected from the blood. On entering into the thyroid follicle cells, iodide radical is oxidized to iodine. Tyrosine is iodinated forming mono and diiodotyrosine, which couple in a reaction forming triiodothyronine ( $T_3$ ). Two molecules of diiodotyrosines couple and consequently form thyroxine ( $T_4$ ).  $T_3$  and  $T_4$  are biologically active forms of thyroid hormones. Among these two,  $T_3$  is biologically more active than  $T_4$ .  $T_4$  has negligible biological activity.

- Thyroid hormones, in cooperation with growth hormone promote many aspects of growth of the body.
- These are essential for **normal differentiation of central nervous system** in the fetus.
- Increase the **basal metabolic rate (BMR)** by enhancing cellular respiration in most tissues. Basal metabolic rate is calorie expenditure at rest.
- Enhance the rate of protein synthesis.

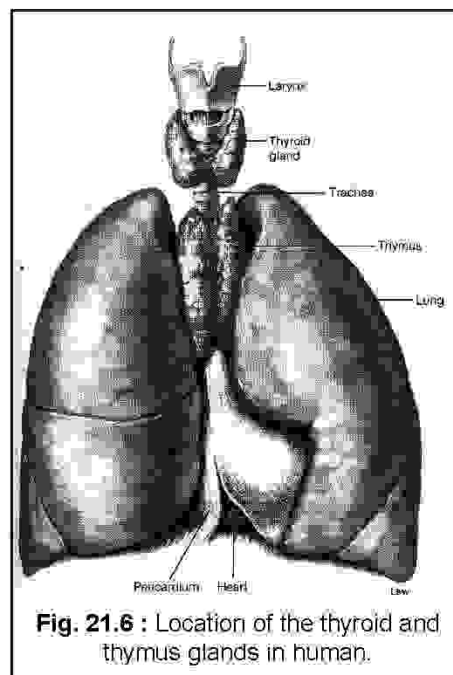

Fig. 21.6 : Location of the thyroid and thymus glands in human.

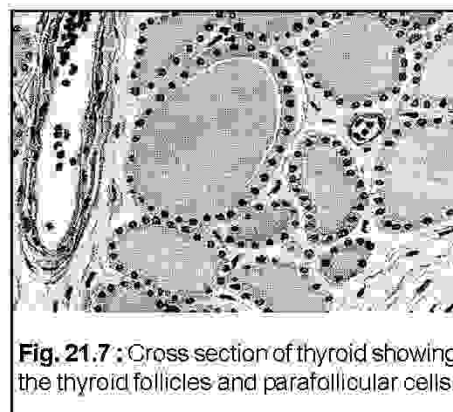

Fig. 21.7 : Cross section of thyroid showing the thyroid follicles and parafollicular cells.

- Have a **hyperglycemic** effect i.e. increases blood glucose level.
- Have a **lipolytic effect** on the liver, thereby increasing the cholesterol level in the blood

**Functions of Calcitonin:** Calcitonin, secreted by the parafollicular cells of the thyroid gland regulates the blood calcium level at a constant by preventing bone dissolution and by promoting the excretion of calcium in the urine.

- **Synergistic, Permissive and Antagonistic Effects of Hormones:**
  - When two hormones cooperate with each other to express an effect, both the hormones are known as **synergists**, the effect is known as **synergistic** and the phenomenon as **synergism**.
  - When a hormone enhances the activity of a second hormone, the effect is known as **permissive effect**.
  - When the action of one hormone is opposite to another, the effect is known as **antagonistic effect**.

### 21.2.3. PARATHYROID GLAND :

There are two pairs of parathyroid glands, one pair being superior and other pair inferior, embedded in the posterior part of the of the thyroid gland [Fig. 21.8 (a)]. Each gland is embedded by a thin connective tissue capsule. The parathyroid cells are arranged into cords or clumps, surrounded by rich network of capillaries. The gland is made up of two types of cells: principal or chief cells and oxyphil cells [Fig. 21.8 (b)]. Oxyphil cells are larger, found either singularly or in small groups. These cells are less numerous than the chief cells.

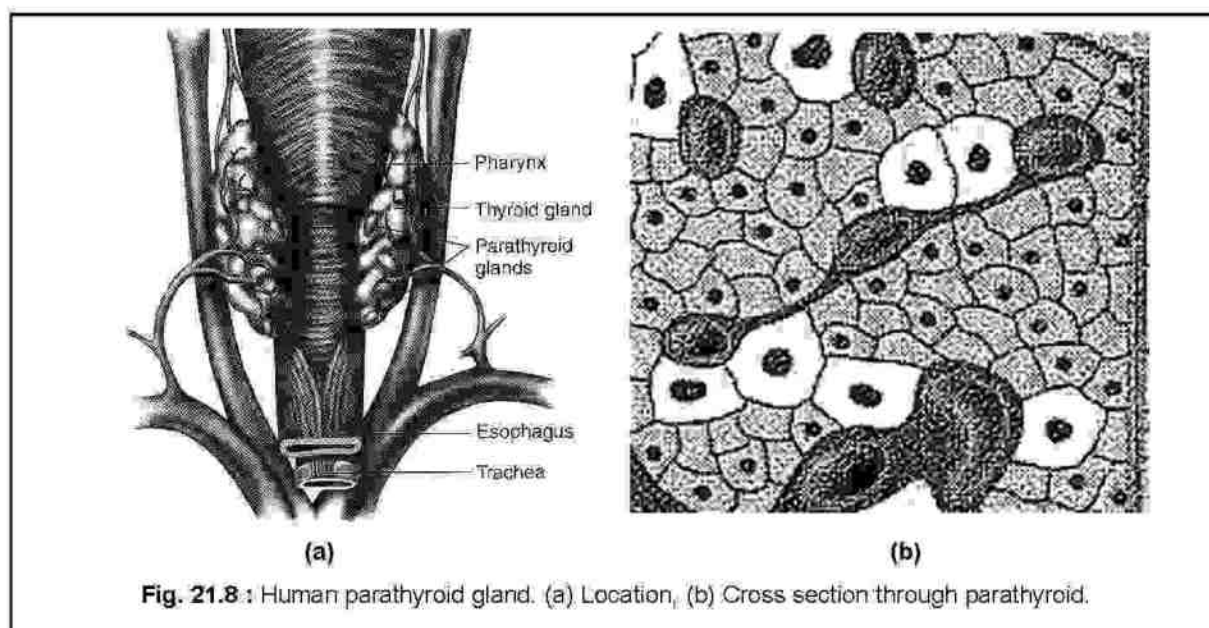

**Fig. 21.8 :** Human parathyroid gland. (a) Location, (b) Cross section through parathyroid.

**Parathyroid hormone (PTH) or parathormone** is the only hormone secreted by the parathyroid glands.

**21.2.3.1. Functions of Parathyroid Hormone:** It promotes an increase in the blood calcium level by acting on the bones, kidneys and intestine. It encourages the osteoclasts (bone resorbing cells) to resorb bone and release calcium into blood. It stimulates the kidneys to reabsorb calcium from the glomerular filtrate.

#### 21.2.4. PANCREAS:

Pancreas is a **composite organ** consisting of two elements: an **exocrine element** secreting pancreatic juice and an **endocrine element** secreting several hormones. The endocrine part is found scattered among the exocrine acini as richly vascularized spherical ball of cells, known as **islets of Langerhans**. Each islet is surrounded by fine fibers of reticular connective tissue. Special staining techniques distinguish four different types of cells such as **alpha, beta, delta** and **pancreatic polypeptide (PP) cells**. Alpha cells constitute about 20% of the entire population of cells and are located around the periphery of the islet. Beta cells are by far the most numerous constituting about 70% of the islet cells and are present primarily at the centre. The remaining cell types are minor and are found scattered throughout the islet.

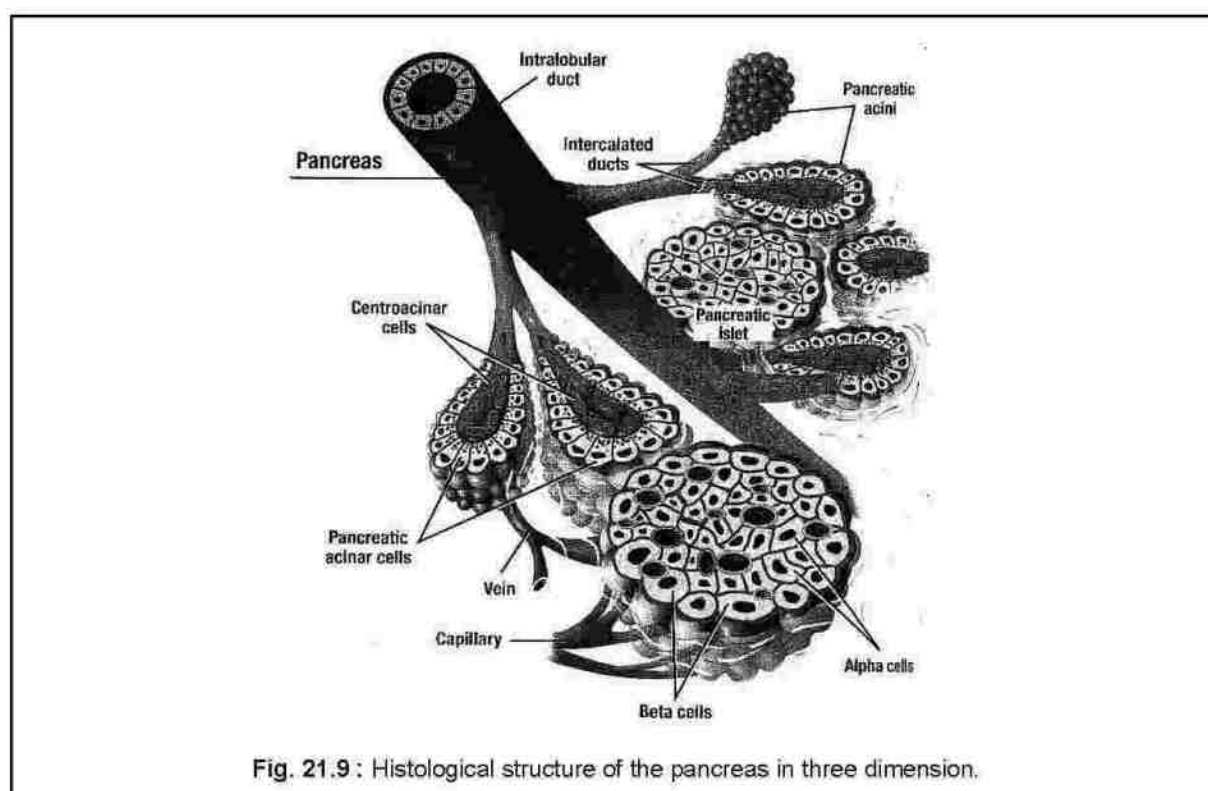

Fig. 21.9 : Histological structure of the pancreas in three dimension.

**21.2.4.1. Hormones of Pancreas:** Each cell type secretes a hormone, which has unique physiological functions. The alpha and beta cells secrete **glucagon** and **insulin**, respectively.

The delta cells secrete **somatostatin**, which has a role in inhibiting the growth hormone secretion. PP cells secrete a **pancreatic polypeptide**, whose functions have not been established as yet.

#### 21.2.4.2. Functions of Insulin :

- Insulin is **hypoglycemic** i.e. it decreases blood glucose level by facilitating glucose entry into adipose tissue cells, muscle cells and liver cells.
- It promotes glycogen synthesis in muscle and liver cells from glucose that has entered into these cells.
- It promotes fatty acid synthesis and triglyceride deposition in adipose tissue.
- It promotes amino acid uptake by muscle and liver cells and increases protein synthesis in such cells.
- It increases lipid synthesis in liver cells.
- Its deficiency causes a disease, known as **diabetes mellitus**. In diabetes mellitus, glucose concentration in the blood is elevated.

#### 21.2.4.3. Functions of Glucagon :

- Glucagon's action is antagonistic to that of insulin.
- Glucagon is **hyperglycemic** i.e. secretion of more glucagon elevates the blood glucose concentration above normal.
- It acts on the liver depot of glycogen, hydrolyzes it and releases free glucose into the blood, thereby elevating the blood glucose level. This breaking down process of glycogen into glucose is known as **glycogenolysis**.
- It promotes **gluconeogenesis** in the liver cells. Gluconeogenesis is a biochemical process, whereby glucose is formed from non carbohydrate source, here in particular from amino acids.

#### 21.2.5. ADRENAL GLAND :

There is a pair of adrenal gland in human. Adrenal gland is also known as **suprarenal gland** because each is associated with the superior pole of the kidney like a cap. It is a composite gland consisting of two elements: an **outer cortex** and an **inner medulla** (Fig. 21.10). Although these two elements are associated together forming a single structure, they have different embryological origins, structures and functions. The medulla is derived from neural ectoderm, while the cortex from mesoderm. Each adrenal gland is surrounded by a dense irregular connective tissue capsule and embedded in adipose tissue at the superior pole of the kidney. The cortex secretes steroid hormones, while the medulla secretes amine hormones.

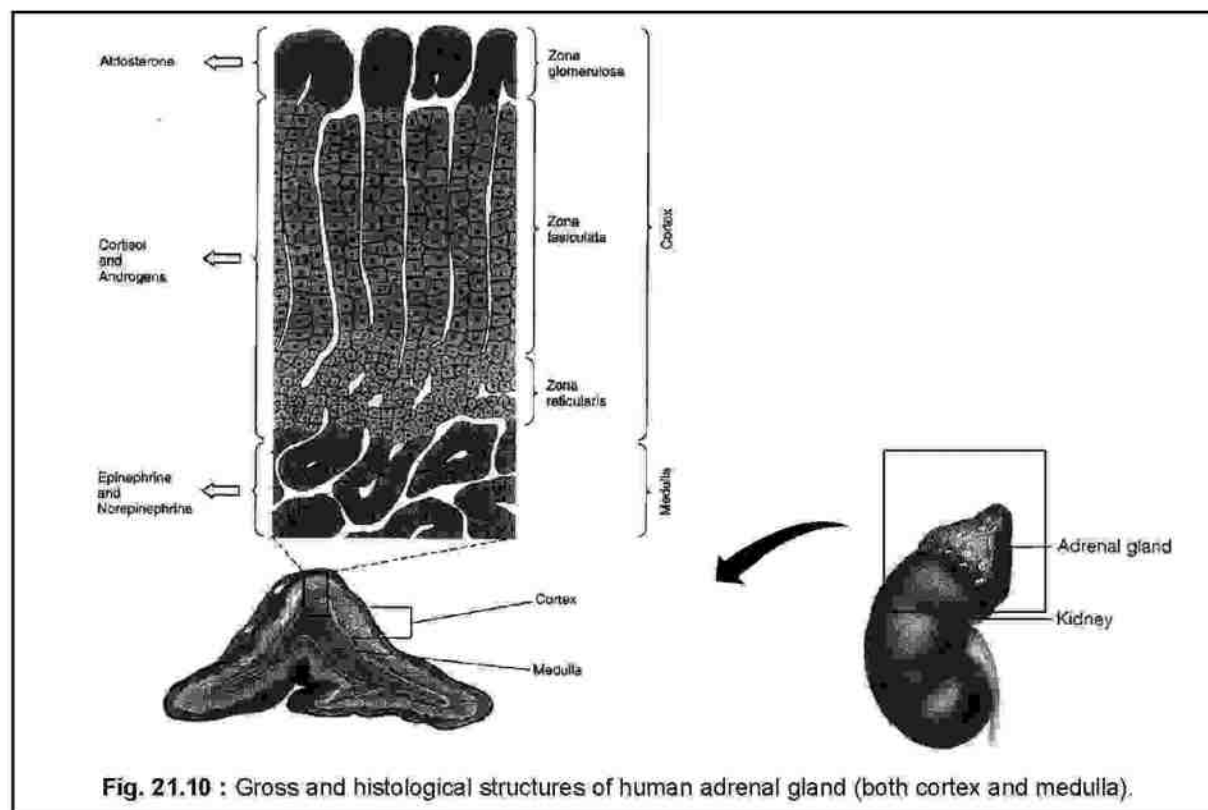

Fig. 21.10 : Gross and histological structures of human adrenal gland (both cortex and medulla).

**21.2.5.1. Structure of Adrenal Cortex:** The cortex has three concentric zones: **1. zona glomerulosa**, **2. zona fasciculata** and **3. zona reticularis** (Fig. 21.10). Although all these zones are of the same organ, they are functionally diverse i.e. secrete different hormones.

- 1. Zona glomerulosa:** This is a thin zone below the capsule. It consists of cells arranged in small clumps. The cells of this zone secrete a hormone called **aldosterone**, a **mineralocorticoid**, concerned with **mineral metabolism**.
- 2. Zona fasciculata:** This is the middle zone and thickest of all. The zone consists of longitudinal cords of cells.
- 3. Zona reticularis:** This zone is innermost and lies adjacent to the medulla. The cells are arranged in cords and clumps.

Zona fasciculata and reticularis secrete two classes of steroid hormones, known as **glucocorticoids** and **androgens**. Among the glucocorticoids are **cortisol** and **corticosterone**. Cortisol is the predominant glucocorticoid in human. Cortical androgens include **dehydroepiandrosterone** and **androstenedione**. Glucocorticoids are concerned with carbohydrate metabolism. The androgens of the cortex are relatively weaker compared to the androgens secreted from the testis. These androgens practically have no effect on males, while in females, express male secondary sexual characters, when secreted in overdoses. All steroid hormones secreted from the adrenal cortex are classed as corticosteroids. Zona fasciculata and zona reticularis are stimulated by ACTH (corticotropin), secreted from the anterior pituitary, while zona glomerulosa is stimulated by **rennin-angiotensin system**.

- **Cushing's Syndrome:**

The disease was first described by Cushing in 1932. This is a hyper-functioning of the adrenal cortex. The syndrome is characterized by an oversecretion of cortisol from the cortex. There are several causes of oversecretion of cortisol. Primarily, it may be due to an adrenocortical tumor (adenoma or carcinoma). A secondary cause may be due to a pituitary tumor in the cells secreting ACTH. More ACTH is secreted from the anterior pituitary. More ACTH will stimulate the cortex to secrete more cortisol, which leads to Cushing's syndrome. The syndrome is characterized by hyperglycemia, hypertension, and muscular weakness.

### 21.2.5.3. Functions of corticosteroids:

- The potent mineralocorticoid, secreted from the zona glomerulosa is aldosterone. It regulates mineral metabolism. It acts on the kidney tubule and promotes Na and water absorption and  $K^+$  excretion in the urine.
  - The predominant glucocorticoid in human is cortisol secreted by zona fasciculata and perhaps also by zona reticularis. It promotes gluconeogenesis (formation of glucose from amino acids) and inhibits glucose utilization. Thus, cortisol elevates blood glucose level i.e. it is hyperglycemic.
  - Cortisol is lipolytic i.e. break down lipids and release fatty acids into the blood.
- All corticosteroids are protein anabolic hormones. They promote protein synthesis.
- Stress stimulates the cortex to secrete more cortisol, which is known to suppress the immune response. More cortisol, primarily enables a subject to cope up with stressful situations. In other words, if the cortisol level is elevated, the subject may die. However, if the stress is prolonged, the immune response continues to be suppressed. This may increase the susceptibility to infections and diseases in the subject.

- **Renin-Angiotensin-Aldosterone System:**

When there is a reduced blood flow and pressure in the renal artery, cells of the juxtaglomerular apparatus of the kidney secrete an enzyme, renin into the blood. The enzyme cleaves a ten amino acid polypeptide, angiotensin I from a plasma protein, angiotensinogen. Angiotensin I reaches the blood capillaries of the lung, where it is again cleaved to form a eight amino acid polypeptide, angiotensin II. Angiotensin II stimulates adrenal cortex to secrete more aldosterone, which promotes retention of more water and salt by the kidneys. The result is an increase in the blood volume, blood pressure and blood flow in the renal arteries.

- **Glucocorticoids as immune response suppressors:**

Glucocorticoids are known to suppress the immune system and hence immune response. These are therefore, used as pills, creams, injections and sprays to suppress the immune response and inflammation. These drugs are useful in treating inflammatory diseases like asthma and rheumatoid arthritis. Some such glucocorticoids used to suppress inflammation are prednisolon and dexamethasone.

**21.2.5.4. Structure of Adrenal Medulla:** Medulla forms the core of the adrenal gland. It is made up of cells that are modified sympathetic post-ganglionic neurons, arranged in cords. The neurons have lost their axons and dendrites during development. These are secretory cells, which synthesize and secrete a class of hormones, known as catecholamines. The catecholamines include epinephrine (adrenaline) and nor-epinephrine (nor-adrenaline). The cells of adrenal medulla stain with chromates and hence are termed as chromaffin cells.

**21.2.5.5. Functions of catecholamines:**

- The effects of catecholamines are similar to those caused by the stimulation by the sympathetic nervous system.
- The catecholamines increase the cardiac output and heart rate.
- Increase respiratory rate and hence metabolic rate.
- Promote hyperglycemia (increase in the blood glucose level) by hepatic glycogenolysis (glycogen breakdown in liver cells).
- Have lipolytic action i.e. stored lipids are broken down and free fatty acids are released into the blood.
- Epinephrine is known as an emergency hormone because it handles emergency situations like hypoglycemia arising due to stress. The response exhibited by the medulla under emergency situations has been termed as fight or flight response.

**21.2.6. PINEAL GLAND:**

There is a single pineal gland, situated on the roof of the third ventricle of diencephalon is encircled by the meninges of the brain. It starts to regress at the age of 7 years and appears in the adult as a fibrous tissue. It is innervated by sympathetic nerves from the superior cervical region, there being no direct connection with the brain.

It secretes a hormone called melatonin. The secretion of this hormone is stimulated by the suprachiasmatic nucleus of the hypothalamus. This nucleus is the centre of circadian rhythm, a rhythm of physiological activity that follows a 24 hour pattern. The activity of this nucleus is influenced by the length of the day (day light) so that it is synchronized to a day night cycle (Fig. 21.11).

### 21.2.6.1. Functions :

- Day light stimulus is perceived by the retina and is transmitted to the suprachiasmatic nucleus via the hypothalamus. The activity of the nucleus is suppressed, thereby decreasing the sympathetic stimulation of the pineal. The consequence is a decrease in melatonin secretion.
- The melatonin secretion increases with darkness during night and reaches a peak at midnight. The regulation of melatonin secretion by light is brought about by a retinal pigment, **melanopsin**.
- Melatonin inhibits the gonadotropin releasing hormone (GnRH) from the hypothalamus. Its secretion in children between 1 to 5 years of age is maximum. Followed by this, there is a steady decline in its level reaching its lowest level at the onset of puberty. This fact suggests about the role of melatonin in the onset of puberty.

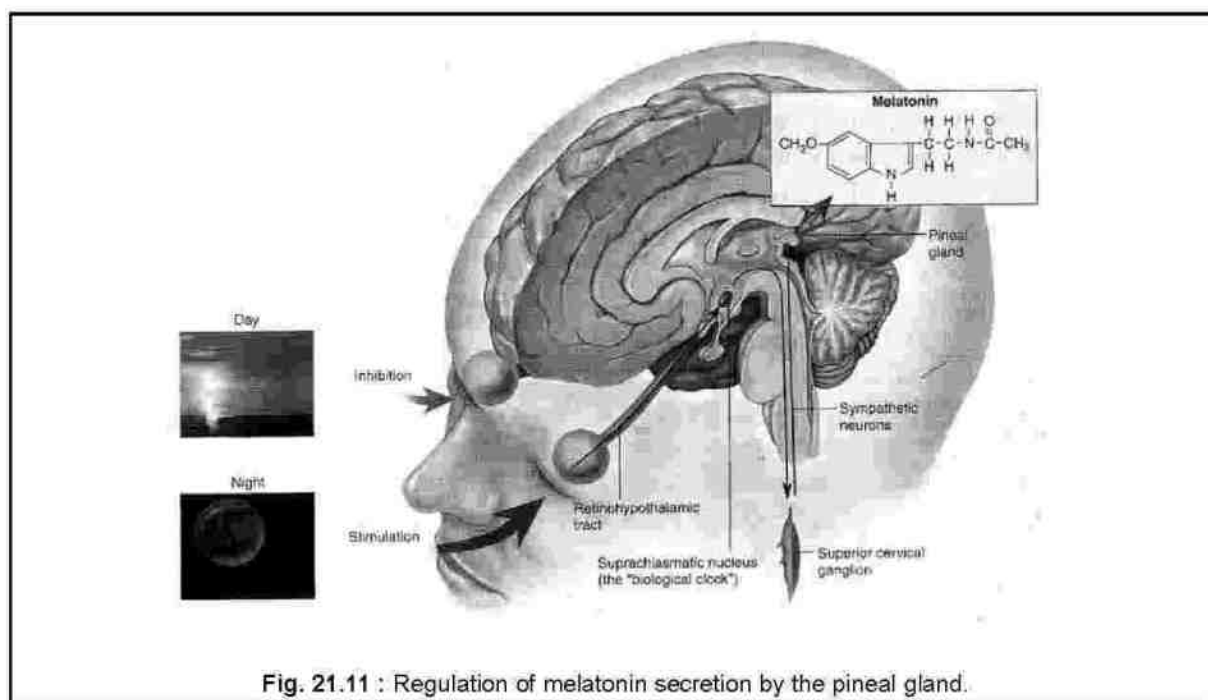

- **Melatonin Pill:**

Melatonin secretion changes, when a person works in night shifts or flies different time zones. The latter induces an effect, which is known as jet lag. In such cases, melatonin pills may be taken to restore normalcy. Melatonin reduces the time period required to fall asleep. It may be useful for elderly people, who suffer from insomnia (loss of sleep).

The cited beneficial effects are not yet proved. Therefore, the opinion is against the uncontrolled use of melatonin pills without the prescription of a practitioner.



### 21.2.7.GONADS:

Gonads are the primary sex organs. There are two types of gonads: **testis in the male** and **ovary in the female**. Accessory sex structures are associated with gonads constituting reproductive systems, the male or the female. Testis and ovary function as endocrine glands in addition to their gamete formation and maturation functions. Most of their hormones are steroid hormones, which are collectively called **gonadal steroids**. However a few peptide hormones are secreted from the gonads.

#### 21.2.7.1 TESTIS:

(a) **Structure (Fig. 21.12)** : Human male has a pair of testis, situated outside the abdominal cavity in a **scrotum**. The scrotum communicates with the abdominal cavity through **inguinal canals**. Each testis is surrounded by a thick connective tissue capsule called **tunica albuginea**. It thickens and extends inwardly into each testis as a **mediastinum testis**. A thin connective tissue septum extends from the mediastinum testis and subdivides it into about 250 compartments called **testicular lobules**, each containing 1-4 coiled **seminiferous tubules**. Each seminiferous tubule is lined by stratified cuboidal epithelium containing dividing spermatogenic cells and large nondividing somatic cells, known as **Sertoli** or **sustentacular cells**. The tight junctions between adjacent Sertoli cells, the basal lamina and the myoid (muscle like) cells constitute a **blood-testis barrier**. The seminiferous tubules lie in a mass of loose connective tissue, containing fibroblasts, muscle like cells, nerves, blood vessels, lymphatic vessels and epithelial cells called **interstitial cells of Leydig**. These interstitial cells of Leydig secrete a class of steroid hormones, known as **androgens**.

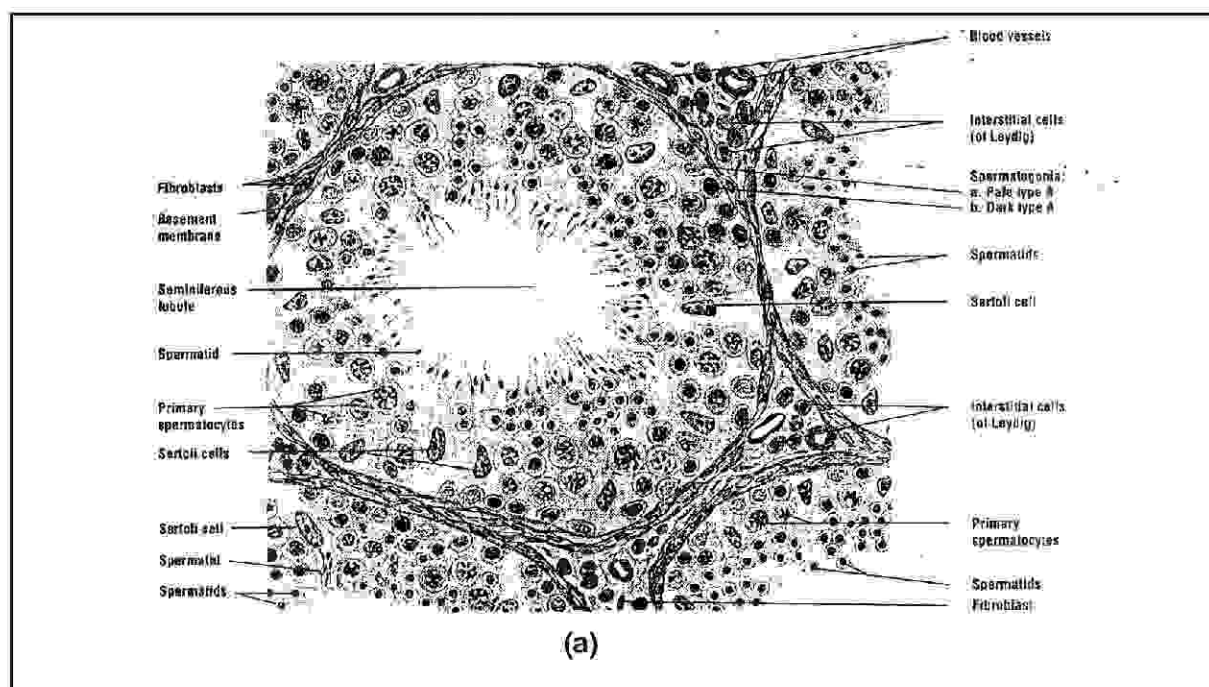

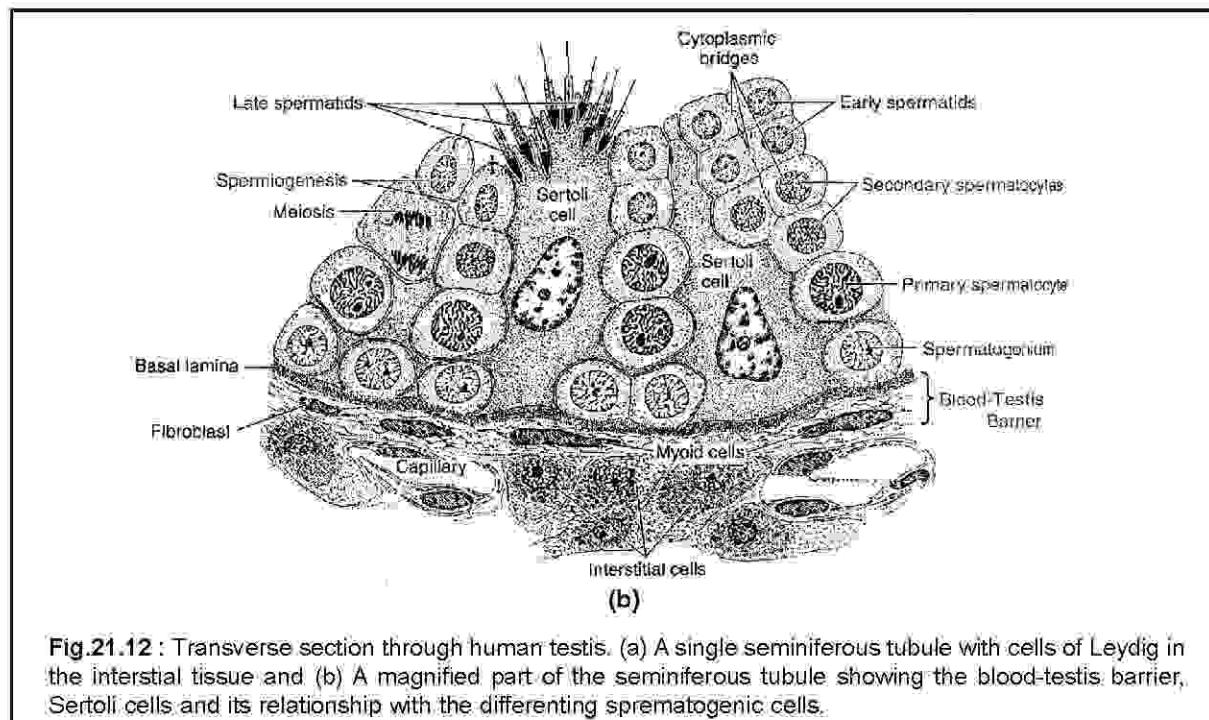

**Fig.21.12 :** Transverse section through human testis. (a) A single seminiferous tubule with cells of Leydig in the interstitial tissue and (b) A magnified part of the seminiferous tubule showing the blood-testis barrier, Sertoli cells and its relationship with the differentiating spermatogenic cells.

**(b) Testicular Hormones:** As mentioned in the preceding section, the interstitial cells of Leydig secrete **male steroid hormones**, collectively called **androgens**. **Testosterone** is the major androgen secreted by the testis. Sertoli cells, cells of Leydig, maturing male germ cells secrete **estradiol**, a predominant female steroid hormone, primarily secreted by the ovary. Sertoli cells are the primary targets of FSH stimulation. Under its influence, **inhibin** and **antimullerian hormone (AMH)** or **mullerian inhibiting hormone (MIH)** are secreted from the Sertoli cells. Sertoli cells contain an enzyme, **aromatase**, which converts testosterone into estradiol. Inhibin negatively feeds back the secretion of FSH from the anterior pituitary. It is made from three polypeptides, namely,  $\alpha$ ,  $\beta A$  and  $\beta B$ .  $\alpha$  joins with either  $\beta A$  or  $\beta B$  to form one or the other type of inhibin.  $\beta A \beta B$  combination forms another hormone, **activin**, which stimulates FSH secretion from the anterior pituitary rather than inhibit it.

**(c) Functions of Testicular Hormones:**

- Along with FSH, testosterone is required for the initiation and continuation of spermatogenesis.
- Testosterone is necessary for the development and maintenance of male genitalia (penis and scrotum).
- It maintains **male accessory sex organs** (prostate, seminal vesicles, epididymis and vas deferens).
- It is essential for the development and expression of **male secondary sexual characters**.

- Inhibin, secreted by the Sertoli cells negatively feeds back the secretion of FSH from the anterior pituitary.
- Antimüllerian hormone (AMH), secreted also by the Sertoli cells inhibits the development and differentiation of müllerian ducts, which later differentiate as the oviducts in the female. The consequence is the differentiation of a wolffian duct, which later differentiates as the vas deference.
- Actiivin, as mentioned earlier, stimulates the secretion of FSH from the anterior pituitary.
- Testosterone has protein anabolic effects i.e. promote protein synthesis in muscle cells.

### 21.2.7.2. OVARY :

(a)Structure (Fig. 21.13): There is a pair of almond shaped ovaries in the pelvic cavity. Unlike the testes, the ovaries are intra-abdominal. A part of the ovary is attached to the broad ligament by a peritoneal fold known as **mesovarium**. Another part is attached to the wall of the uterus by an ovarian ligament.

Histologically, the ovary consists of single surface layer of squamous to cuboidal epithelial cells, constituting the germinal epithelium. Inner to this layer, there is a mass of dense irregular

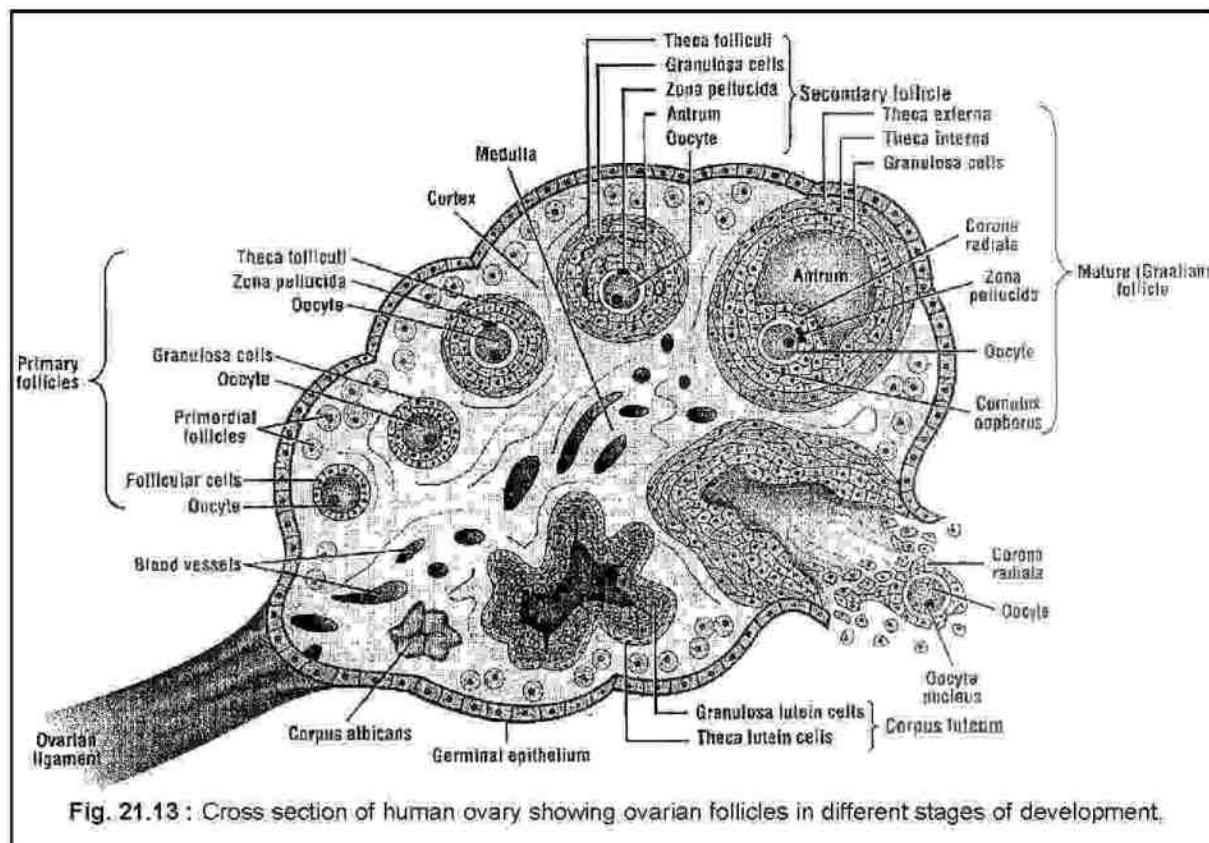
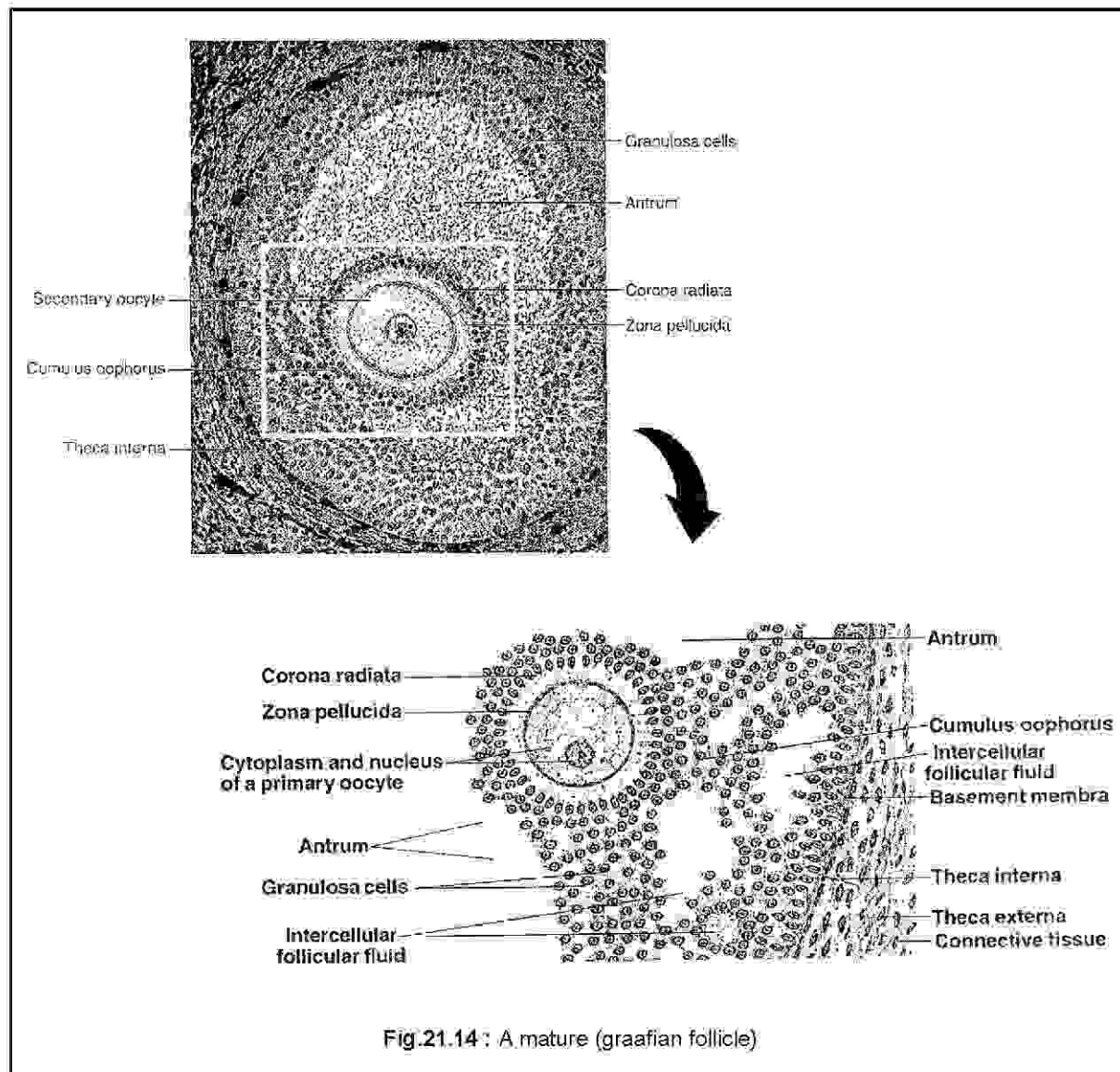

Fig. 21.13 : Cross section of human ovary showing ovarian follicles in different stages of development.



connective tissue called **tunica albuginea**. Internal to the tunica albuginea is a cortex. Below the cortex, there is a highly vascularized mass of connective tissue called medulla or stroma. There is no distinct boundary between the cortex and medulla or stroma.

The germ cells differentiate as oogonia during the embryonic life. The oogonia divide by equational divisions and enter into the phase of maturation as primary oocytes. **The primary oocytes are arrested at the diplotene stage of the second maturation division and remain as such until the onset of puberty.** A primary oocyte is surrounded by a single layer of squamous follicle cells. This structure constitutes a **primordial follicle**. These follicles are situated in the cortex and at puberty, are stimulated by FSH and LH to differentiate into several later stage follicles, such as **primary, secondary or antral and mature or graafian follicles**. Concomitant with the changes in the oocyte, the surrounding follicle cells grow by mitosis and form layers of

cuboidal cells, known as granulosa cells. The **granulosa cells** are surrounded by thecal cells from the stroma. A thin **basement membrane** separates the granulosa from the theca. As the follicle grows, a follicular fluid accumulates among the granulosa cells. As the fluid grows in volume, it accumulates in a cavity called **antrum**. The granulosa cells segregate into granulosa cells surrounding the developing oocyte and peripheral granulosa cells. The oocyte with its surrounding granulosa cells remain attached to the peripheral granulosa cells by a hillock of the same granulosa cells, known as **cumulus oophorus**. The ovarian follicle possessing the above mentioned features constitutes a **mature or graafian follicle (Fig. 21.14)**. It contains a secondary oocyte, ready for ovulation.

**(b) Ovarian Hormones:** The granulosa cells are the primary source of the **female steroid hormones**, collectively known as **estrogens**. The granulosa cells also secrete **inhibin**, which negatively feeds back FSH secretion from the anterior pituitary. The major estrogen secreted from the ovary is **estradiol**. The secondary oocyte is released from the **graafian follicle**, which then turns into a blood filled **corpus haemorrhagicum**. The blood is being absorbed *in situ* and the structure turns into a **corpus luteum**. Both the granulosa and thecal cells constitute the luteal cells, which start secreting **estradiol** and **progesterone**. Granulosa cells alone can't secrete estrogens. They require the help of thecal cells. The thecal cells secrete androgens under the stimulation of LH, which diffuse into granulosa cells and are converted into estrogens under the stimulation of FSH.

**(c) Functions of Ovarian Hormones:**

- Estradiol is responsible for the growth and development of the vagina, uterus, fallopian tube and oviduct at the onset of puberty.
- Along with prolactin (PRL), it is necessary for the growth of breasts at the onset of puberty.
- Though not remarkable like those in males, female secondary sexual characters develop and differentiate under the influence of estradiol.
- Estradiol with FSH and LH regulates the menstrual cycle.
- Inhibin negatively feeds back FSH secretion from the anterior pituitary.
- Progesterone is essential for preparing the uterus for implantation of the embryo following fertilization. In this case, the corpus luteum persists and continues to secrete progesterone. If fertilization doesn't occur, corpus luteum regresses.
- Progesterone is essential for the maintenance of pregnancy i.e. as long as pregnancy continues, corpus luteum persists and continues to secrete progesterone.

### 21.3. MECHANISM OF HORMONE ACTION :

Hormones are chemical messengers, which act on specific target cells and induce them to express an appropriate physiological response so as to make the cell function in a state of physiological homeostasis. In this process, a hormone molecule acts as the **first messenger**,

which transmits a signal to the target cell in either of the two ways. It either transmits the signal to an intracellular molecule of the target cell or directly to the genes present in the nucleus of the target cell. Whatever may be the means, the hormone molecule acts as a signaling molecule and this signal is translated into an effect or response in the target cell. The expression of the response continues as long as the hormone molecule transmits the signal. When a state of equilibrium in respect of the particular response has reached, the hormone molecule stops transmitting the signal. The consequence is that the target cell stops expressing the response. The amplified intracellular physiological response induced by the signaling hormone is known as **signal transduction**.

All hormones act on their target cells by two fundamental mechanisms. A class of hormones, are water soluble or polar, which can't cross the plasma membrane lipid barrier, transmit their signals from outside on binding to their membrane integral protein receptors. These include hormones such as peptides and proteins, glycoproteins and catecholamines with the exception of thyroid hormones and glucocorticoids. All steroid hormones are lipid soluble. They can cross the lipid barrier and indeed, they do so and move to the nucleus via the cytoplasm and transmit the signal directly to the genes. Thus, the gene expression is either elevated or depressed.

### 21.3.1. Hormones that use second messenger mechanism (Fig. 21.15) :

This mechanism is exhibited by water soluble peptide and protein, glycoprotein and catecholamine hormones. Each such hormone has a specific membrane integral receptor protein. Close to the receptor protein, on the inner side of the membrane, there is a **G protein (guanyl nucleotide protein)** in an inactive state. There is another membrane integral protein in close vicinity of the G protein, this time an enzyme, known as **adenylate or adenylyl cyclase**. It too is a membrane integral protein and is present in an inactive state. When activated, it catalyzes the conversion of ATP into 3', 5' cyclic AMP. This molecule acts as a **second**

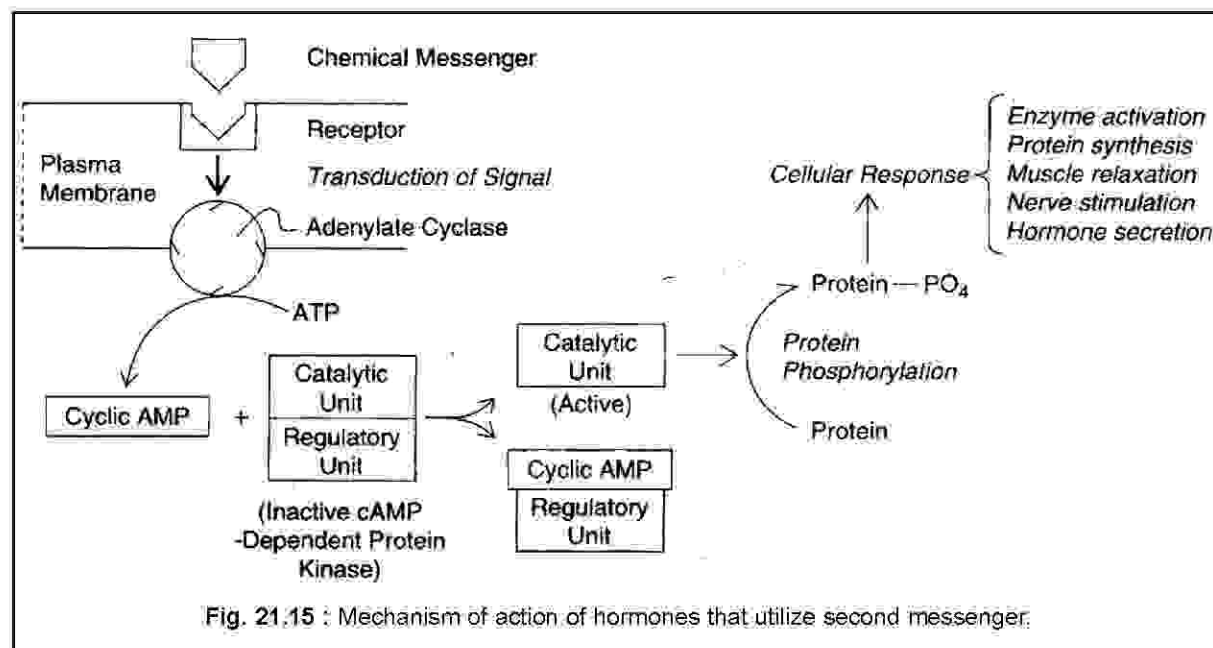

Fig. 21.15 : Mechanism of action of hormones that utilize second messenger.

**messenger**, the hormone molecule being the first messenger. **E.W.Sutherland (1972)** demonstrated the role of 3',5' cyclic AMP as the prime second messenger in the mechanism of the above mentioned class of hormones. The second messenger takes over from the hormone molecule the act of transmitting the signal in an intracellular environment. At the end the signal is translated into a response through one or a few biochemical reactions. At equilibrium, an intracellular enzyme, phosphodiesterase hydrolyses 3', 5' cyclic AMP into an inactive form. Under this situation, the signal transmission stops and the physiological response comes to a halt. Finally the hormone molecule dissociates from its receptor. In addition to cyclic AMP, **cyclic GMP (cyclic guanosine monophosphate)**, **inositol triphosphate**, **diacyl glycerol** and **calcium ions** so act as second messengers.

**21.3.2. Hormones that bind to nuclear receptors (Fig. 21.16) :** Unlike the hormones discussed in the above section, steroid hormones are nonpolar and hence can cross the hydrophobic lipid barrier of the plasma membrane of target cells. **Thyroid hormones** and **glucocorticoids** also can cross the barrier into target cells. These hormone molecules are bound to their specific **protein receptors**, while in circulation. They cross over the plasma membrane barrier to the cytoplasm and are translocated to the nuclear envelop with the help of **cytoplasmic receptor proteins**. The molecules cross over the nuclear envelop and **bind to their specific nuclear receptors**. The nuclear receptor-hormone molecule complex then binds to a specific part of the DNA, known as **response element** of that particular hormone. The response element of the DNA (gene) undergoes transcription followed by translation. A polypeptide is synthesized, which indeed is the cellular response to that hormone molecule. This class of hormones, therefore, acts by elevating or depressing the expression of specific genes.

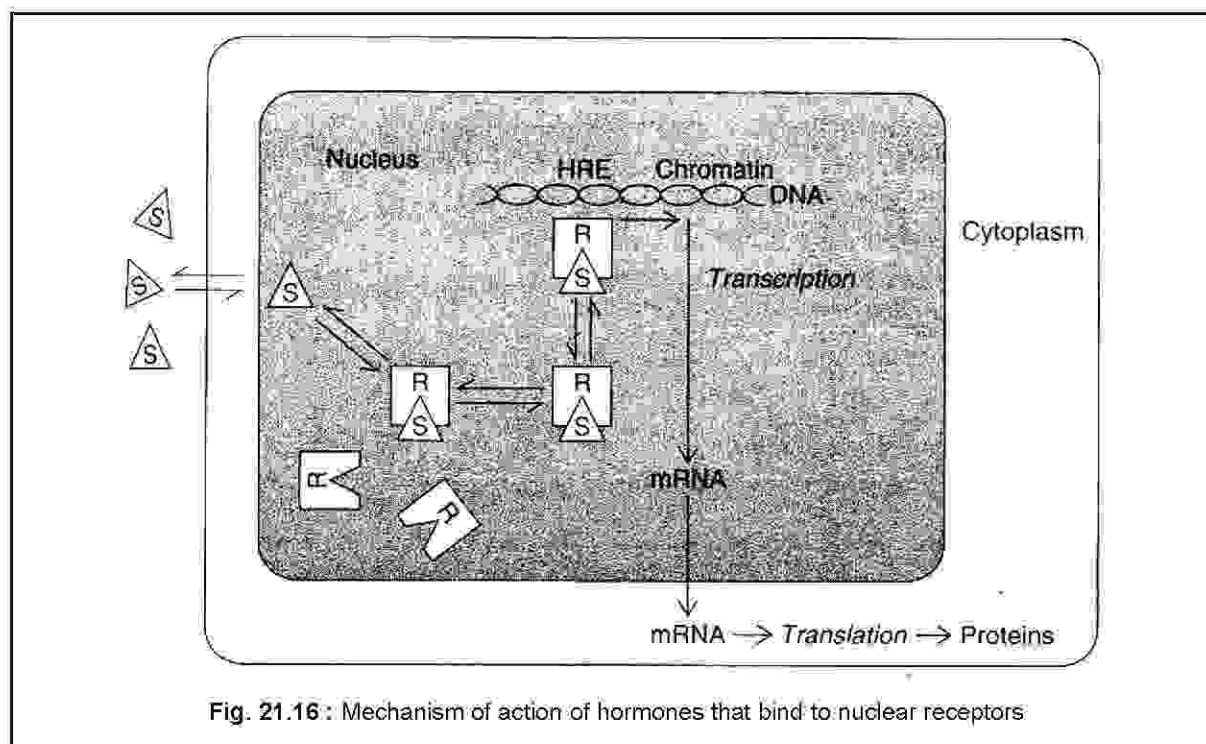

Fig. 21.16 : Mechanism of action of hormones that bind to nuclear receptors

## 21.4. HYPO AND HYPER ACTIVITY OF ENDOCRINE GLANDS :

Very precise quantities of hormones are required to exhibit a physiological response. Secondly, hormones act in their lowest possible concentrations. Therefore, hormone concentrations need to be delicately balanced. If there is a small fluctuation in the concentration of a hormone, there is a marked change in the physiological response. Mostly these changes are short lived and the function shifts back to normal by adjustments by several mechanisms. One of such mechanisms is the feedback mechanism. If the abnormal situation in the hormone concentration persists, we identify it as a malfunctioning of the endocrine gland. The glands do so due to infection, noxious chemical agents or loss of responsiveness to the target hormone. Hypo-activity of a gland refers to its sub-normal secretion of a hormone, while hyper-activity refers to above-normal secretion of a hormone. In the event of hypo- and hyper activity, some pathological conditions, sometimes very severe are expressed.

### 21.4.1. Hypo- and Hyper-secretion of Growth Hormone:

Growth hormone promotes skeletal growth by acting on epiphysial cartilages of long bones (epiphysis is the growing cartilaginous end of a long bone) of children and adolescents. This action is mediated by somatomedins. Recall that growth hormone doesn't directly act on its target cells, but rather through somatomedins. Somatomedins are synthesized by liver cells under the influence of growth hormone. Somatomedins act on chondrocytes (cartilage forming cells) and stimulate them to divide and secrete more and more cartilage substance. A part of this cartilage is changed into bone, thus enabling the bone to grow in length. The epiphyses become bony at the onset of puberty, but nevertheless, growth hormone continues to be secreted and continues to exercise its influence. Against this backdrop, let's consider three instances of abnormal growth hormone functioning.

- **Gigantism:**

**Hypersecretion of growth hormone in children produces gigantism. As mentioned earlier, growth hormone acts on epiphyses and promotes linear growth of long bones before the epiphyses have closed. Such children are known to grow to a height of upto eight feet.**

**21.4.1.1. Dwarfism:** An inadequate secretion of growth hormone during the growing years results in dwarfism. Contrary to this concept on dwarfism, another condition of dwarfism has been identified as Laron dwarfism. In this case, there is an adequate growth hormone secretion. However, the target cells don't respond to the growth hormone molecules due to a lack of receptors. This is considered as a genetic defect.

**21.4.1.2. Acromegaly:** An excess secretion of growth hormone after the closure of the epiphyses can't lengthen the bones and hence can't increase the height. There is, however, disfigured growth of bones, wherever there is an opportunity of growth. The consequence is an



elongation of jaw bones, deformities in the bones of the face, hands and feet. Accompanied by these changes, the soft tissues also grow and the skin becomes coarse.

#### 21.4.2. Hypo- and Hyper functioning of Thyroid :

There is a very delicate hypothalamus-anterior pituitary-thyroid axis i.e. precise TRF secretion from the hypothalamus is required for the secretion of TSH from the anterior pituitary, which in turn stimulates the thyroid gland to release thyroid hormones into the blood. This axis needs to be at equilibrium and if it shifts, hypo- and hyper-functioning of the gland, manifested by severe to very severe pathological conditions arise. Hypo- and hyper-functioning of the thyroid are studied under hypo- and hyper-thyroidism heads, respectively.

**21.4.2.1. Hypo-thyroidism:** Subnormal secretion of thyroid hormones from the thyroid gland is known as hypo-thyroidism. There are four possible reasons for the subnormal secretion of thyroid hormones, namely, **defective thyroid, insufficient hypothalamic thyrotropin releasing hormone, inadequate TSH secretion from the anterior pituitary and intake of inadequate iodine** in the diet. It is manifested in three forms, such as, **endemic (iodine deficiency) goiter, myxedema and cretinism.**

**(a) Endemic (Iodine deficiency) Goiter:** This thyroid abnormality results from a deficiency of dietary iodine. In the absence of iodine, the thyroid is unable to produce sufficient  $T_3$  and  $T_4$  (thyroid hormones) and hence negative feedback mechanisms of the hypothalamus and anterior pituitary is lacking. The consequence is a high level of secretion of TSH from the anterior pituitary, which exerts its direct influence on the thyroid gland. The thyroid is stimulated to undergo hyperplasia (abnormal growth), visible from outside as a swelling in the neck region. Such people have a low basal metabolic rate and decreased resistance to cold stress. They gain body weight and become lethargic.

- **Myxedema:**

**Hypothyroidism in adults causes myxedema. It is caused by an accumulation of mucoprotein in the subcutaneous connective tissue. The symptoms include swelling of the hands, feet, face and tissue surrounding the eyes.**

**(b) Cretinism:** This is another form of hypo-thyroidism. Greatest risk of developing this abnormality is between first trimester of prenatal life to six months after birth. Children require thyroxine for normal body growth, since thyroxine promotes protein synthesis. More importantly, during the prenatal life, thyroxine is essential for proper development of the central nervous system. If, during this period, thyroid hormones are absent, normal development of the brain is hampered and such children suffer from severe mental retardation. Treatment with thyroxine soon after birth restores the development of normal intelligence.

**21.4.2.2. Hyper-thyroidism :** Above normal secretion of thyroid hormones causes hyper-thyroidism. Recall from your study on mechanism of hormone action that glycoprotein hormones

and a few more bind to membrane integral receptors of target cells. TSH, being a glycoprotein hormone from the anterior pituitary binds to receptors on thyroid gland cells and stimulates them to secrete thyroid hormones. However, in an abnormal situation, the protein receptors behave as though they are foreign molecules and incite the immune system to produce antibodies, which are called **autoantibodies**. These autoantibodies, in a competition to TSH, bind to the TSH receptors and stimulate more and more thyroid hormone production and release. Excess thyroid hormones can't negatively feed back the stimulation by autoantibodies. The consequence is a continuous stimulation of the thyroid, which then undergoes hyperplasia and develops a goiter. This condition has been termed as **Graves' disease** or **toxic goiter** or **thyrotoxicosis**. This condition is accompanied by bulging eyes or **exophthalmus** due to edema in orbits and hence this abnormality is also identified as **exophthalmic goiter**. There is an increase in the basal metabolic rate accompanied by weight loss, nervousness, irritability and intolerance to heat.

#### 21.4.3. Diabetes mellitus :

Diabetes mellitus is the physiological consequence of an increase in blood glucose concentration above normal (hyperglycemia). It was known that the deficiency of insulin only contributes towards hyperglycemia. **Frederick Banting and Charles Best (1921)** demonstrated that insulin deficiency causes hyperglycemia and this physiological condition is known as diabetes mellitus. This condition has been classed as **type 1 diabetes mellitus** or **insulin dependent diabetes mellitus** (explained in the text later).

However, it is now known that there may be adequate insulin, but nevertheless there is hyperglycemia. This indicates that in some instances, insulin may be unable to stimulate the uptake of glucose by the cells. The role of insulin is to facilitate the uptake of glucose from the blood by cells. Diabetes mellitus is characterized by **polyurea** (frequent urination), **polydipsia** (frequent feeling of thirst), **polyphagia** (increased appetite), **glycosuria** (excretion of sugar in the urine), **hyperglycemia** (elevated blood glucose level), **ketosis** (formation of ketone bodies), **acidosis** and **coma**.

There are two major forms of diabetes mellitus: **type 1. [insulin dependent diabetes mellitus (IDDM)]** and **type 2. [non insulin dependent diabetes mellitus (NIDDM)]**.

**21.4.3.1. Type 1:** Type 1 diabetes, once known as **juvenile onset diabetes**, since it appears in people below the age of 20, is insulin dependent. In type 1, the beta cells are progressively destroyed by autoimmune attack by killer T lymphocytes. The consequence is that there is an insulin deficiency. Exogenous insulin is required to sustain life. It accounts for only 10% of documented diabetes cases. It is non-genetic. Obesity has no correlation with the incidence of type 1 diabetes.

**21.4.3.2. Type 2:** Type 2 accounts for 90% of the documented cases. Since it afflicts people over the age of 40, it is also known as **maturity onset diabetes**. It occurs due to an inability of insulin to facilitate the uptake of plasma glucose by cells. It is hereditary. People with both type 2 parents are at a high risk of getting this diabetes.

**21.4.4. Addison's Disease :**

It is a disorder of the adrenal cortex. and was identified and characterized by **Addison (1855)**. It is caused by an inadequate secretion of both glucocorticoids and mineralocorticoids from the adrenal cortex. Inadequate glucocorticoids fail to negatively feed back the ACTH secretion from the anterior pituitary. Mineralocorticoid and glucocorticoid secreting cells may be exhausted leading to the complete destruction of the adrenal cortex. The symptoms are hypoglycemia, low blood pressure, increased melanin pigmentation of the skin, sodium and potassium imbalance, dehydration, rapid weight loss and general weakness. A person, if not administered with corticosteroids, dies sooner or later mainly due to an electrolyte imbalance. The one described is Addison's disease of primary origin. Secondary and tertiary origins of the same may be due to hypothalamus (a failure of CRH secretion) and anterior pituitary (absence of functional ACTH secreting cells), respectively.

---

## SAMPLE QUESTIONS

### GROUP - A

#### (Objective-type Questions)

1. Choose the correct answer:

- (i) Banting and Best (1921) established that:
  - (a) Deficiency of thyroxine causes hypothyroidism
  - (b) Oversecretion of cortisol causes Cushing's syndrome
  - (c) Deficiency of insulin causes hyperglycemia
  - (d) Oversecretion of growth hormone causes gigantism
- (ii) Which one of the facts about hormones is correct?
  - (a) Hormones are proteins
  - (b) Hormones are released into the blood
  - (c) Hormones have no specific targets
  - (d) Hormones are secreted by exocrine glands.
- (iii) Which one of the following is not true?
  - (a) Steroid hormones act through second messengers
  - (b) Glycoprotein hormones include TSH, FSH and LH.
  - (c) Epinephrine and norepinephrine are catecholamines.
  - (d) Sertoli cells secrete androgen binding protein.
- (iv) Which of the following statements about the hypothalamic releasing and release-inhibiting hormones is true?
  - (a) They are secreted into capillaries in the median eminence.
  - (b) They are transported by portal veins to the anterior pituitary.
  - (c) They stimulate the secretion of specific hormones from the anterior pituitary.
  - (d) All of the above are true.
- (v) The hormone primarily responsible for increasing the basal metabolic rate and promoting the maturation of the brain is:
  - (a) Cortisol
  - (b) ACTH
  - (c) TSH
  - (d) Thyroxine
- (vi) Which of the following statements about adrenal cortex is true?
  - (a) It is not innervated by nerve fibers.
  - (b) It secretes some androgens.
  - (c) The zona glomerulosa secretes aldosterone.
  - (d) The zona fasciculata is stimulated by ACTH.
  - (e) All of these are true.
- (vii) Which of the following statements about insulin is true?
  - (a) It is secreted by alpha cells of islet of Langerhans.
  - (b) It is secreted in response to a rise in blood glucose concentration.

- (c) It stimulates the synthesis of glycogen and fat.
  - (d) Both (a) and (b) are true.
  - (e) Both (b) and (c) are true.
- (viii) Steroid hormones are secreted by
- (a) Adrenal cortex only.
  - (b) Gonads only.
  - (c) Thyroid only.
  - (d) Both (a) and (b).
  - (e) Both (b) and (c).
- (ix) The secretion of which of the following hormones will be augmented in a person with endemic goiter.
- (a) TSH
  - (b) Thyroxine
  - (c) Triiodothyronine
  - (d) All of the above.
- (x) Which of these hormones uses cAMP as a second messenger?
- (a) Testosterone
  - (b) Cortisol
  - (c) Insulin
  - (d) Epinephrine
- (xi) Which of these hormones may have a role in circadian rhythm.
- (a) Estradiol
  - (b) Insulin
  - (c) ACTH
  - (d) Melatonin
- (xii) Which one of the following about ACTH is true?
- (a) It stimulates the entire adrenal cortex.
  - (b) It stimulates zona glomerulosa only.
  - (c) It stimulates both zona fasciculata and reticularis.
  - (d) It stimulates zona reticularis only.
- (xiii) Which one of the following statements is false?
- (a) Corpus luteum secretes progesterone.
  - (b) Progesterone maintains pregnancy.
  - (c) FSH stimulates interstitial cells of Leydig.
  - (d) Sertoli cells are somatic cells, secreting androgen binding protein.
- (xiv) Granulosa cells secrete:
- (a) Cortisol
  - (b) Estadiol
  - (c) Testosteron
  - (d) Progesterone
- (xv) Which of the following is correct?
- (a)  $T_4$  changes into  $T_3$  in the target cell.
  - (b)  $T_3$  changes into  $T_4$  in the taget cell.
  - (c)  $T_3$  and  $T_4$  act as such on target cell.
  - (d)  $T_3$  changes into  $T_4$  and vice versa in the target cells.

**2. Express the following statements in one word:**

- (i) The study of glands secreting hormones and their functions.
- (ii) The part of the brain that secretes the releasing and release-inhibiting hormones.
- (iii) The stalk that attaches the pituitary with the hypothalamus.
- (iv) The part of the hypothalamus, where the primary capillary plexus is present.
- (v) The division of the anterior pituitary that secretes the tropic hormones.
- (vi) The hormone, which acts on the renal tubule and promotes the absorption of water.
- (vii) The hormone that regulates the height before adolescence.
- (viii) The hormone that promotes early stages of gametogenesis.
- (ix) The hormone that promotes the development of breasts.
- (x) The hormone that acts on the smooth muscle of uterus and facilitates the birth of a baby.
- (xi) The blood vessel that carries the releasing release-inhibiting hormones from the hypothalamus to the anterior pituitary.
- (xii) The iodinated glycoprotein present in the colloid of the thyroid.
- (xiii) Hypothyroidism in children with severe mental retardation.
- (xiv) Hyperthyroidism, which is caused by auto-immune attack
- (xv) The hormone that stimulates the interstitial cells of the gonads.
- (xvi) A synonym for adrenal gland.
- (xvii) The cortical steroid hormone that regulates mineral metabolism.
- (xviii) The pathological condition in which inadequate glucocorticoids and mineralocorticoid fail to negatively feedback the secretion of ACTH from the anterior pituitary.
- (xix) The hormone that fluctuates in its concentration, when one flies different time zones.
- (xx) The formation of glucose from noncarbohydrates.
- (xxi) Breakdown of glycogen into glucose.
- (xxii) The interstitial cells that secrete androgens.
- (xxiii) The graafian follicle turns into a progesterone secreting endocrine structure following ovulation.
- (xxiv) The phenotypic characters, which identify the sex of the individual.
- (xxv) A collective name for adrenal medullary hormones.

**3. Correct the sentences without changing the words underlined:**

- (i) Thyroid stimulating hormone is an amine hormone.
- (ii) Posterior pituitary (neurohypophysis) originates from neural ectoderm.
- (iii) Pars tuberalis secretes all the tropic hormones of the anterior pituitary.
- (iv) Pituitary is attached to the epithalamus.
- (v) Growth hormone induces hyperglycemia.

- (vi) Growth hormone excess in an adult human causes gigantism,
- (vii) Prolactin induces milk ejection.
- (viii) Adrenocorticotrophic hormone acts on adrenal gland.
- (ix) Deficiency of antidiuretic hormone causes diabetes mellitus.
- (x) Releasing inhibiting hormones are secreted from the posterior pituitary.
- (xi) Calcitonin is secreted from the parathyroid gland.
- (xii) Alpha cells of islet of Langerhans secrete somatostatin.
- (xiii) Adrenocorticotrophic hormone acts on zona glomerulosa and promotes the secretion of aldosterone.
- (xiv) Cortisol and epinephrine are hyperglycemic by promoting gluconeogenesis and glycogenolysis, respectively.
- (xv) Cells of the adrenal cortex are called chromaffin cells.
- (xvi) Day light induces the pineal gland to secrete less melatonin.
- (xvii) Sertoli cells secrete androgens.
- (xviii) Granulosa cells of the ovary secrete estrogens.
- (xix) Steroid hormones use the second messenger mechanism in their action on target cells.
- (xx) Dwarfism is a consequence of prolactin deficiency before adolescence.
- (xxi) Deficiency of dietary iodine causes thyrotoxicosis.

**4. Fill in the blanks with appropriate words:**

- (i) The active substance from the small intestine that stimulated the release of pancreatic juice was discovered by \_\_\_\_\_ and \_\_\_\_\_ in 1902.
- (ii) The word hormone was used by \_\_\_\_\_ in 1905 for the active substance, secretin.
- (iii) Glycoprotein hormones include \_\_\_\_\_, FSH and LH.
- (iv) Epinephrine and norepinephrine together constitute a group of hormones, known as \_\_\_\_\_.
- (v) All steroid hormones are derived from the parent compound, \_\_\_\_\_.
- (vi) The role of 3,5 cAMP as a second messenger in the mechanism of hormone action was suggested by \_\_\_\_\_.
- (vii) Some hormones act through cell membrane receptors that stimulate adenylate cyclase activity and formation of \_\_\_\_\_.
- (viii) The pituitary gland is attached to the floor of a part of fore brain, known as \_\_\_\_\_.
- (ix) The pituitary is constituted by adenohypophysis and \_\_\_\_\_.
- (x) The anterior pituitary is regulated by \_\_\_\_\_, a part of the diencephalon.
- (xi) Adrenal medulla is constituted by cells that stain with chromates and hence are known as \_\_\_\_\_ cells.
- (xii) Posterior pituitary secretes two hormones, namely \_\_\_\_\_ and \_\_\_\_\_.
- (xiii) The group of hormones that binds to nuclear receptors is derived from the parent compound, \_\_\_\_\_.

- (xiv) Tropic hormones are secreted from \_\_\_\_\_ of the anterior pituitary.
- (xv) The hormone, \_\_\_\_\_ promotes breast development in the female.
- (xvi) Oversecretion of growth hormone in adults causes an abnormality, known as \_\_\_\_\_.
- (xvii) ACTH is formed from a larger polypeptide, known as \_\_\_\_\_.
- (xviii) FSH stimulates the Sertoli cells to synthesize androgen binding protein and two hormones, namely inhibin and \_\_\_\_\_.
- (xix) During development, the regression of mullerian ducts occur in the male by a hormone called antimullerian hormone. This hormone is secreted from the \_\_\_\_\_ cells of the testis.
- (xx) The hormone \_\_\_\_\_ is responsible for the ejection of milk from the breast of the lactating mother.
- (xxi) The growth promoting effects of growth hormone are mediated by \_\_\_\_\_, polypeptides synthesized by the liver cells under its influence.
- (xxii) Delta cells of the pancreas synthesize \_\_\_\_\_, which acts as growth hormone inhibiting hormone.
- (xxiii) Parafollicular cells of the thyroid gland secrete a hormone, known as \_\_\_\_\_.
- (xxiv) The iodinated glycoprotein present in the thyroid follicle is known as \_\_\_\_\_.
- (xxv) Interstitial cells of the testis are the targets of action of \_\_\_\_\_.
- (xxvi) Blood calcium level is monitored by hormones \_\_\_\_\_ and \_\_\_\_\_.
- (xxvii) The releasing and inhibiting hormones of the hypothalamus act on the anterior pituitary via a blood vessel, known as \_\_\_\_\_.
- (xxviii) Alpha cells of the pancreatic islets secrete a hormone, known as \_\_\_\_\_.
- (xxix) Over secretion of thyroid hormones causes an abnormality of the thyroid, known as \_\_\_\_\_.
- (xxx) The enzyme \_\_\_\_\_ catalyzes the conversion of ATP into 3,5 cyclic AMP.
- (xxxi) Estrogens are secreted by \_\_\_\_\_ cells of the ovary.
- (xxxii) Corpus luteum is an important source of a steroid hormone, \_\_\_\_\_.
- (xxxiii) Day Night cycle is regulated by a hormone, \_\_\_\_\_, secreted from \_\_\_\_\_.
- (xxxiv) \_\_\_\_\_ has been designated as emergency hormone.
- (xxxv) Inadequate secretion of both glucocorticoids and mineralocorticoids from the adrenal cortex causes a disease, known as \_\_\_\_\_.
- (xxxvi) During stress, the immune system is suppressed by the hormone \_\_\_\_\_.
- (xxxvii) There is an insulin insufficiency in \_\_\_\_\_ diabetes mellitus.
- (xxxviii) Severe retardation of the nervous system in children due to a lack of thyroid hormones has been identified as \_\_\_\_\_.
- (xxxix) Excess release of \_\_\_\_\_ can lead to water retention and consequently high blood pressure.



**GROUP - B****(Short Answer-type Questions)**

1. **Answer the following within three sentences each:**
  - (i) What is the relationship between hypothalamus and anterior pituitary?
  - (ii) Pituitary is not a master gland. Is it correct?
  - (iii) How are insulin and glucagon related?
  - (iv) Name the hormone secreted by the delta cells of the pancreatic islet. What is its function?
  - (v) Pancreas is a mixocrine gland. Explain
  - (vi) Why are catecholamines termed as emergency hormones?
  - (vii) How does cortisol handle stress?
  - (viii) Explain diabetes incipidus.
  - (ix) What is the main cause of type 1 diabetes mellitus?
  - (x) What is corpus luteum? What is its role?
  - (xi) What are secondary sexual characters? Which hormone regulates these in males?
  - (xii) What is a glycoprotein hormone? How many of these you have studied?
  - (xiii) What is a steroid hormone? How does it act on its target cell?
  - (xiv) How many hormones are secreted from the posterior pituitary? Mention one important function of each.
  - (xv) What is a flight or flight response?
2. **Differentiate between two words in the following pairs of words:**
  - (a) Exocrine gland and Endocrine gland
  - (b) Enzyme and Hormone
  - (c) Peptide hormone and Steroid hormone
  - (d) Anterior pituitary and Posterior pituitary
  - (e) Insulin and Glucagon
  - (f) Adrenal cortex and Adrenal medulla
  - (g) Epinephrine and Norepinephrine
  - (h) First messenger and Second messenger
  - (i) Testosterone and Estradiol
  - (j) Follicle stimulating hormone and Lutenizing hormone
  - (k) Estrogen and Progesterone
  - (l) Hypothyroidism and Hyperthyroidism
  - (m) Endemic goiter and Exophthalmic goiter
  - (n) Type I diabetes mellitus and Type II diabetes mellitus
  - (o) Diabetes mellitus and Diabetes incipidus

**GROUP - C****(Long Answer-type Questions)**

1. Give an account of the structure of human pituitary gland and describe the functions of hormones secreted from it.



