

9

Electromagnetic Induction

We have seen how a magnetic field is created by an electric current. The effect was discovered in 1820. It made some of the then scientists to search for the inverse effect. They tried to find if electric current could be obtained in a loop with the help of a magnetic field. The success came in 1831 when a new phenomenon called **electromagnetic induction** was discovered. The credit went to **Michael Faraday** of England and **Joseph Henry** of U.S.A. who obtained it almost simultaneously and independently. The discovery provided enough scope to produce electric current in large scale. It led to the invention of modern generators (dynamo) and transformers. Let us discuss this new phenomenon and its technological implications in this chapter.

9.1 Electromagnetic induction :

Electromagnetic induction is the phenomenon in which electric current is induced in a closed conducting loop by varying the magnetic flux linked by the loop with time. Two simple experiments led to the discovery of the phenomenon.

(a) Experiment No.1

Let a closed conducting loop C be connected to a sensitive galvanometer G.

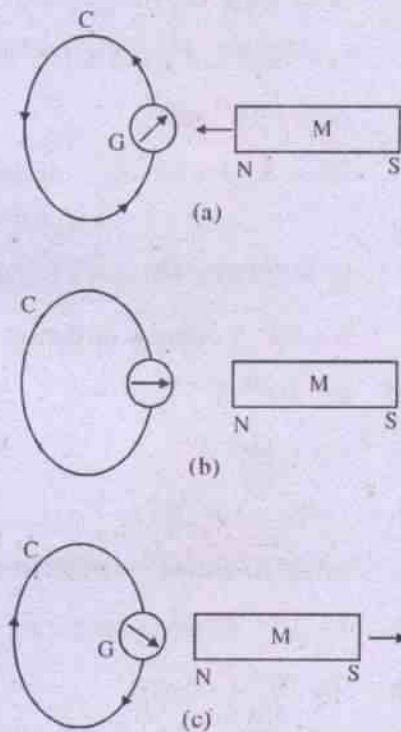

(Induced current due to relative motion between a coil and a bar magnet)

Fig. 9.1

If a bar magnet with its north pole N is thrust into the coil, it is seen that the galvanometer is deflected momentarily during the motion of the magnet. This indicates a momentary current in the galvanometer even if there is no known source of emf in the circuit.

The current disappears when the magnet stops moving.

It appears again but in the opposite direction when the magnet is moved back in its path.

The experiment may be repeated by moving the south pole S of the bar magnet towards or away from the coil. The deflections as obtained in the case of the moving N-pole are repeated in opposite sense.

A little analysis shows that

- (i) a current appears only when there is relative motion between the coil C and the magnet. It stops if the relative motion ceases;
- (ii) faster motion causes greater current;
- (iii) if the motion of the north pole towards the current causes anticlockwise current, the motion of the south pole causes clockwise current.

The current so produced in the loop was named *induced current* and the corresponding emf as *induced emf* by Faraday. The phenomenon was called *electro magnetic induction*.

(b) Experiment No. 2

The same phenomenon can be obtained by using two closely placed adjacent loops or coils (Fig. 9.2)

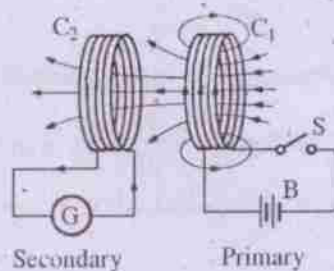

Fig. 9.2

Here C₁ and C₂ are two conducting coils. C₁ is connected to a battery B and a switch S. C₂ is connected to a sensitive galvanometer G. C₁ and C₂ are called *primary* and *secondary* coils respectively.

If we close the switch S to turn on a current in C₁, the meter G in C₂ denotes a current for the moment. As the current in C₁ becomes steady, no current in C₂ is observed. On opening the switch S in C₂, the meter G shows a momentary deflection again, but in the opposite sense. The *current* so obtained in C₂ in either case is nothing but the *induced current*. Note that no current is observed in C₂ so long as the current in C₁ is steady and there is no relative motion between C₁ and C₂.

It is interesting to note that a current appears in C₂ if it is bodily displaced relative to C₁ even if the current in C₁ is steady. What may be the possible cause ?

Let us analyse the observations in both the above experiments.

In Expt. 1, coil C is placed in the magnetic field of the magnet M. The magnetic lines of induction spread from its north pole N. So long as C and M are stationary, C embraces a fixed number of such lines. As the N-pole of M is moved towards C, this number increases with time. The increase apparently causes the conduction electrons in the loop to move (*induced current*) and provides energy (*induced emf*) for their motion. When the magnet stops moving, the number of induction lines through the loop no longer changes and hence induced emf and current disappear.

Similar thing may happen if the magnet is kept fixed and the coil is moved towards it.

Quantitatively we may measure it by the change (increase/decrease) of the magnetic flux linked with the area of the coil with time. It is this change that produces induced emf and hence induced current in C. However, the magnitude of this emf/current depends on how fast the change occurs. In other words it depends on the rate of change of magnetic flux linked with C.

A similar analysis applies to the observations in Expt. 2 too. Here we recall that a current carrying closed coil behaves as a magnetic dipole and produces a magnetic field around it. When the switch is open there is no current in C_1 . Hence there is no magnetic line of induction. When we turn on the current in C_1 , the increasing current builds up a magnetic field around it and coil C_2 remains in this field. While the field builds, the number of lines of induction through C_2 increases gradually and during this time induced emf and hence current are obtained in it. When the current in C_1 reaches a steady value, the lines of induction through C_2 become fixed and induced emf and current disappear.

Again it is the change of magnetic flux through C_2 with time that causes induced emf and induced current in it. The magnitude depends on how fast the change takes place.

Such analysis led Faraday to formulate his law of electromagnetic induction.

9.2. Faraday's law of electromagnetic induction :

"Whenever the magnetic flux linked with a conducting coil changes with time, induced emf. is produced in it and the magnitude of this emf is proportional to the rate of change of this flux.

$$\begin{aligned} \text{Mathematically} \quad \bar{\varepsilon} &\propto \frac{\Delta\phi}{\Delta t} \\ \Rightarrow \quad \bar{\varepsilon} &= K \frac{\Delta\phi}{\Delta t} \quad \dots 9.2.1 \end{aligned}$$

where $\bar{\varepsilon}$ stands for the average induced emf within the interval Δt , and $\frac{\Delta\phi}{\Delta t}$ is the average rate of change of magnetic flux linked by the coil over the interval. K is a constant of proportionality and is chosen as 1 in S.I. system of units. Then from eq. 9.2.1

$$\bar{\varepsilon} = \frac{\Delta\phi}{\Delta t} \quad \dots 9.2.2$$

If the circuit contains N turns of the coil each of the same area, then

$$\bar{\varepsilon} = N \frac{\Delta\phi}{\Delta t} \quad \dots 9.2.3$$

A negative sign is introduced in the R.H.S. of eq. 9.2.3 due to direction of induced emf and current in the closed loop. This will be explained in the next section (Lenz's Law).

$$\bar{\varepsilon} = -N \frac{\Delta\phi}{\Delta t} \quad \dots 9.2.4$$

From eq. 9.2.4 if $N = 1$ turn and $\frac{\Delta\phi}{\Delta t} = 1 \frac{\text{weber}}{\text{sec}}$

$\bar{\varepsilon} = -1$ volt. This may be verified by taking the dimensions of all quantities in the R.H.S. of eq. 9.2.4. It comes to be $ML^2 T^{-3} A^{-1}$ which is the dimension of energy per unit charge. It is measured in volt in S.I. system.

As the variation of magnetic flux linked by a coil continuously takes place over an interval, it is often required to find the instantaneous induced emf developed in the coil. Then eq. 9.2.4. may be written as

$$\varepsilon = -N \frac{d\phi}{dt} \quad \dots 9.2.5$$

where ε represents the instantaneous value of the induced emf and $N \frac{d\phi}{dt}$, the instantaneous rate of change of flux linked by all turns of the coil.

Example 9.2.1 A coil of 500 turns is threaded by a magnetic flux of 7×10^{-5} weber. If the flux changes to 3×10^{-5} weber in 0.010 sec, what average induced emf is developed in the coil? Find the average induced current if the resistance of the coil is 10 ohms.

Solution

Given that

$$\phi_1 = 7 \times 10^{-5} \text{ weber}, \phi_2 = 3 \times 10^{-5} \text{ weber}$$

$$\therefore \Delta\phi = \phi_2 - \phi_1 = -4 \times 10^{-5} \text{ weber}$$

$$\Delta t = 0.010 \text{ sec.}$$

$$N = 500, R = 10 \text{ ohm}$$

$$\begin{aligned} \therefore \bar{\epsilon} &= -N \frac{\Delta\phi}{\Delta t} = -500 \times \frac{-4 \times 10^{-5} \text{ weber}}{0.010 \text{ sec}} \\ &= 2 \frac{\text{weber}}{\text{sec}} \end{aligned}$$

$$= 2 \text{ volt.}$$

$$\therefore \bar{I} = \frac{\bar{\epsilon}}{R} = \frac{2 \text{ volt}}{10 \text{ ohm}} = 0.2 \text{ Amp.}$$

It is seen from eq. 9.2.4 and 9.2.5 that induced emf in a coil depends on

(1) the number of turns (N) of the coil and

(2) the rate of change of magnetic flux, $\left(\frac{\Delta\phi}{\Delta t}\right)$ linked with the coil.

It implies that no emf is induced in a coil if the flux linked by it does not change, i.e. $\Delta\phi = 0$.

We have seen in chapter 8 that the flux linked by a coil of area S is given by

$$\begin{aligned} \phi &= \bar{B} \cdot \bar{S} = \bar{B} \cdot \hat{n} S \\ &= BS \cos\theta \end{aligned} \quad \dots 9.2.6$$

where \hat{n} is unit vector, normal to the area S and θ is the angle between \hat{n} and \bar{B} . (Fig. 9.3) Then instantaneous emf induced in it is given by

$$\epsilon = -\frac{d\phi}{dt} = -\frac{d}{dt}(BS \cos\theta) \quad \dots 9.2.7$$

Hence the general means by which we can **change** the magnetic flux through a coil are

(i) by changing the magnetic field \bar{B} of the coil, or

(ii) by changing the area of the coil, or

(iii) by changing the angle between the direction of \bar{B} and

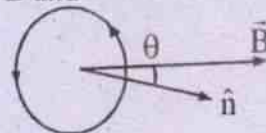

Fig. 9.3

(Flux through a closed coil lying in a field \bar{B}) the area \bar{S} of the coil i.e. by changing θ . We shall discuss all these different ways to produce induced emf in a coil.

Generation of induced emf and induced current in a closed coil by moving any pole of a magnet towards or away from the coil is an example of the first type. It is described in Faraday's experiment. Here \bar{B} at the coil changes with time and hence induced emf is produced.

9.3 Lenz's law

As stated earlier the negative sign given in the right hand side of eq. 9.2.5 is in accordance with a law given by *H. F. Lenz*. It states that

"In all cases of electromagnetic induction the direction of the induced current is such that it opposes the change that produces it."

To see how it applies, let us recall the experiments described in 9.1. In the experiment No. 1, the coil C with the galvanometer G remains in the magnetic field of the bar magnet M and embraces certain flux. This flux increases

with time as the north pole N of the bar magnet is pushed into the coil C (fig.9.4)

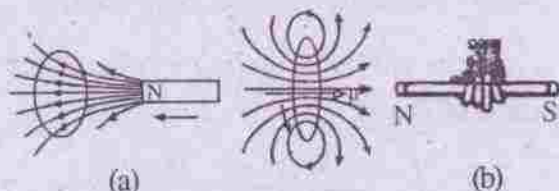

Fig. 9.4

Lenz's law at work. As the magnet is moved toward the loop a counterclockwise current is induced in loop, the current produces its own magnetic field, with magnetic dipole moment μ so as to oppose the motion of the magnet.

During the push an anticlockwise current appears in the coil as seen along the magnet. Why is it so? We know that a current loop sets up a magnetic field and behaves as a magnetic dipole. The face of the loop seen to have anticlockwise current behaves as the north pole and the opposite face behaves as the south pole. The magnetic field lines of this dipole are shown in Fig. 9.4a. These lines through the loop produce a field \vec{B} in the opposite direction of the field lines (\vec{B}) of the bar magnet and thus tend to decrease the magnetic flux linked by C. This explains the validity of *Lenz's law*.

If the bar magnet now stops and then is pulled away from the coil the current in C becomes clockwise as seen from the magnet side. This current tends to increase the field within the coil and hence the magnetic flux linked by it. Is not it in accordance with Lenz's law?

Moreover the law confirms the principle of conservation of energy. How?

We have seen that the magnetic field produced by the coil (Fig. 9.4) tends to oppose the push of the north pole of the magnet towards it. To maintain the push, work has to be done and this work appears as heat in the coil C. The thermal energy so produced in the system is nearly equal to the work done in pushing the

magnet. We neglect here the energy that is radiated out of the system during induction.

Suppose, the current in the coil C would have been clock wise during the push of the north pole N. Then the face of the coil towards N would have behaved as a south pole. This would have attracted the magnet and no work would have been done on the system. However, Joule heat must be produced because of the current in the loop but without any input work. Is it not in violation of the principle of conservation of energy?

Hence, the induced current during the push of the north pole towards the coil must be anticlockwise according to Lenz's law and in conformity with the principle of conservation of energy.

In a similar manner we can explain the development of clockwise current in the loop when the north pole of the magnet is receded away from the loop too. It is to be noted here that we must have a closed circuit to have induced current. If there is no closed circuit it is to be mentally completed between the ends of the conductor. Then Lenz's law should be used to find the direction of current. This enables us to determine the polarities of the open circuit conduction.

Example 9.3.1 The N-pole of a magnet is brought down towards a flat coil of 20 turns lying on a table. If the flux from the N-pole passing through the coil changes from 1.42×10^{-3} weber to 8.66×10^{-3} weber in 0.216 sec, find the magnitude of induced emf. Is it clockwise or anticlockwise as you look down at the coil?

Solution

Given $N = 20$

$$\phi_1 = 1.42 \times 10^{-3} \text{ weber}$$

$$\phi_2 = 8.66 \times 10^{-3} \text{ weber}$$

$$\Delta t = 0.216 \text{ S}$$

$$\therefore \bar{\epsilon} = -\frac{\Delta\phi}{\Delta t} = -N \frac{(\phi_2 - \phi_1) \text{ weber}}{0.216 \text{ sec}}$$

$$= -20 \times \frac{(8.66 - 1.42) \times 10^{-3} \text{ W}}{0.216 \text{ S}} = -0.67 \text{ volt.}$$

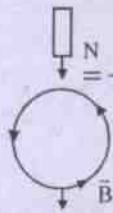

The induced emf in the coil as seen from above (i.e. from the magnet side) is anticlockwise.

This emf gives rise to a current in the coil anticlockwise so that the magnetic field produced by the current upwards opposes the increasing magnetic field.

9.4 Motional emf

Motional emf is one type of induced emf set up in a conductor moving in a magnetic field. Let us examine the situation under which it is produced.

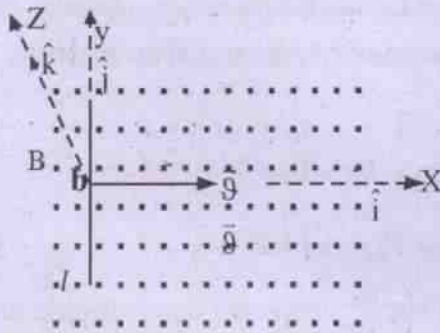

Motional emf due to motion of a conductor in a magnetic field

Fig. 9.5

Suppose we have a uniform magnetic field \vec{B} directed along +z axis i.e. towards the reader and perpendicular to the plane of the diagram. Thus $\vec{B} = \hat{k}B$ (fig. 9.5). Let a conductor ab of length ℓ lie along the y axis in the plane of the diagram as shown, i.e. $\vec{\ell} = \hat{j}\ell$. If ab is moved towards right along x-axis with a uniform velocity $\vec{v} (= \hat{i}v)$, each free electron in ab experiences a force \vec{F}_n and

$$\vec{F}_n = -e(\vec{v} \times \vec{B}) = -e(\hat{i}v \times \hat{k}B) = -e(-\hat{j})vB$$

$$\Rightarrow \vec{F}_n = \hat{j}e v B \quad \dots 9.4.1$$

Such a force on an equivalent +ve charge =

$$\vec{F}'_n = -\hat{j}e v B \quad \dots 9.4.2$$

This means the free electrons move along $\vec{\ell}$ towards b and accumulate there. It creates a deficiency of -ve charges at a which becomes a +ve terminal. This is maintained so long as ab continues to move in the field.

Force \vec{F}_n is of nonelectrostatic origin. Let us denote such a force per unit charge as \vec{E}_n and call it the nonelectrostatic field. The direction of \vec{E}_n is from b to a i.e. along $-\hat{j}$.

As more and more free electrons accumulate at b, an electrostatic field \vec{E}_e gradually builds up. \vec{E}_e is from a to b and it opposes \vec{E}_n . Electron accumulation at b stops when $\vec{E}_n + \vec{E}_e = 0$ i.e. $\vec{E}_n = -\vec{E}_e$. This is the equilibrium state at which ab becomes a seat of induced electromotive force. It is called the motional emf.

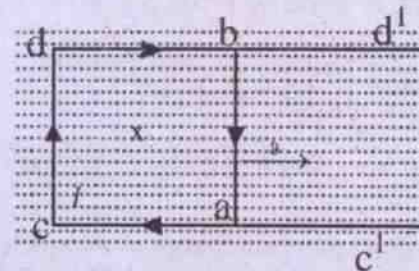

Induced current due to motional emf

Fig. 9.6

Induced current

In stead of moving along in the magnetic field, suppose ab moves over the parallel sides of a U shaped conductor c'edd' with the

velocity \vec{v} (fig. 9.6). Since $c'dd'$ is stationary, the free electrons within it do not experience any magnetic force. But they do experience the electrostatic force and move along the conductor bdc to a . It creates a current (clockwise) along acd to b outside ab and from b to a within ab (fig. 9.6). As a result of this the excess charges at a and b are reduced and \vec{E}_e decreases. The magnetic force \vec{F}_n , however, maintains the emf within ab by displacing further free electrons to b and the process continues. Thus a **clockwise current** in the closed path $acdba$ is established so long as ab is slid in the given magnetic field. This current is the **induced current**.

Magnitude of motional emf and the current due to it.

Motional emf is produced due to the movement of ab in the magnetic field \vec{B} . During such motion the free electrons are transferred to the end b . It is equivalent to the accumulation of +ve charges at a .

Let us imagine a charge $+q$ to move from b to a through a distance l under the force \vec{F}'_n .

$$\vec{F}'_n = -\hat{j} q \mathcal{B} \quad \dots 9.4.3$$

The work W done by \vec{F}'_n on q is given by

$$W = \vec{F}'_n \cdot \vec{ba} = \vec{F}'_n \cdot (-\hat{j}l) \\ \Rightarrow W = (-\hat{j} q \mathcal{B}) \cdot (-\hat{j}l) = q \mathcal{B} l$$

$$\therefore \text{work done per unit charge} = \frac{W}{q} = \mathcal{B} l$$

$$\text{i.e. motional emf } \varepsilon = \mathcal{B} l \quad \dots 9.4.4$$

In all our discussions so far we have considered the velocity \vec{v} of the conductor to be perpendicular to \vec{B} . However, in some cases \vec{v} may make angle θ with the direction of \vec{B} .

In such cases the component of \vec{v} perpendicular to \vec{B} is taken into account in eq. 9.4.4 and we write.

$$\text{motional emf } \varepsilon = \mathcal{B} l \sin \theta \quad \dots 9.4.5$$

clearly when $\theta = 0$ or π , $\varepsilon = 0$.

When the ends of conductor ab are connected by the fixed conductor $acdb$, the circuit is closed and induced current is set up. If R is the net resistance of the system, the current I is given by

$$I = \frac{\varepsilon}{R} = \frac{\mathcal{B} l}{R} \quad \dots 9.4.6$$

More generally, if ε is given by 9.4.5, I is given by

$$I = \frac{\varepsilon}{R} = \frac{\mathcal{B} l \sin \theta}{R} \quad \dots 9.4.7$$

While a current is maintained in the closed loop, conductor ab experiences a magnetic force \vec{F}_m because of the presence of the magnetic field \vec{B} .

$$\vec{F}_m = I(\vec{l} \times \vec{B}) = I(-\hat{j}l \times \hat{k}B) \\ \Rightarrow \vec{F}_m = -\hat{i} I l B \quad \dots 9.4.8$$

Thus \vec{F}_m acts in the opposite direction of motion of ab and tends to retard its motion. Hence to maintain its uniform velocity, work has to be done. This work done per unit time i.e. the power P , necessary to maintain the velocity \vec{v} is given by

$$P = -\vec{F}_m \cdot \vec{v} = \hat{i} I l B \cdot \hat{i} v \\ \Rightarrow P = I l B v \quad \dots 9.4.9$$

$$\text{clearly } P = I(\mathcal{B} l) = I \varepsilon \quad \dots 9.4.10$$

Also using eq. 9.4.6

$$P = \frac{\mathcal{B}^2 l^2 v^2}{R} \quad \dots 9.4.11$$

It is thus seen that the input mechanical power in the system is converted to electrical power and is ultimately dissipated as joule heat per sec. This confirms the principle of conservation of energy during the process.

Fleming's right hand rule

Fleming's right hand rule gives the direction of induced current.

Suppose we stretch out the thumb, the fore finger and the middle finger of our right hand at right angles to one another (fig. 9.7). If the **fore finger** indicates the direction of magnetic field \vec{B} and the **thumb**, the **direction motion** (i.e. of \vec{v}) of the conductor then the **middle finger** gives the direction of **induced current**.

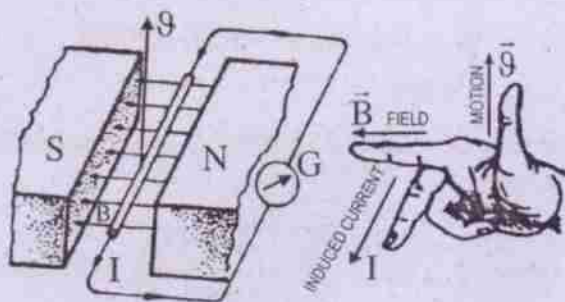

Fig. 9.7

Motional emf from Faraday's law

Motional emf produced in the loop $acdb$ (fig. 9.6) can be obtained using Faraday's law too. Let us consider the arrangement in Fig. 9.6. The stationary conductor $c'edd'$ is in xy plane with its sides $cd=l$ parallel to y -axis and the sides cc' and dd' parallel to x -axis. The magnetic field $\vec{B}(= \hat{k}B)$ is along z -axis, and is perpendicular to the plane of the loop. The sliding conductor of length l is placed at ab at a distance x from cd and parallel to it at time $t=0$ (say).

If S is the area enclosed by the closed loop $acdb$ at $t=0$, then $S=lx$ and

$$\vec{S} = \hat{k}lx$$

\therefore Magnetic flux linked by $S = \phi = \vec{S} \cdot \vec{B}$

$$\text{i.e. } \phi = \hat{k}lx \cdot \hat{k}B = Blx \quad \dots 9.4.12$$

As the conductor ab is slid to the right with velocity $\vec{v} = \hat{i}v$, the area S increases with time. This results in increase of flux ϕ linked by the loop.

The rate of increase of $\phi = \frac{d\phi}{dt} = \frac{d}{dt}(Blx)$

$$\text{i.e. } \frac{d\phi}{dt} = B \ell \frac{dx}{dt} = B \ell v \quad \dots 9.4.13$$

($\because B$ and l are of fixed value)

Hence by Faraday's law, the magnitude of induced emf in the loop i.e.

$$|\varepsilon| = \frac{d\phi}{dt} = B \ell v \quad \dots 9.4.14$$

$$\text{The induced current } I = \frac{|\varepsilon|}{R} = \frac{B \ell v}{R} \quad \dots 9.4.15$$

Thus we see that the values of ε and I are the same as obtained in eq. 9.4.4 and 9.4.6.

The direction of the induced current is determined by applying Fleming's right hand rule. This gives the direction of current in ab from b to a and thus the current in the closed loop $abcd$ is clockwise.

The direction of I can also be obtained using Lenz's law. Since the **cause** of induced emf and induced current in the loop is **the motion of conductor ab towards right** (fig. 9.6) along $+x$ axis, it (i.e. the motion of ab) must be opposed by I . This happens infact because the conductor ab is moved along \hat{i} against the **opposing magnetic force acting on it**. The magnetic force \vec{F}_m on ab must be along $-ve x$ axis i.e. along $-\hat{i}$. We have,

$$\vec{F}_m (\text{on } ab) = I(\vec{l} \times \vec{B})$$

$$\text{i.e. } -\hat{i} F_m = I(B\hat{x} \times \hat{k}) \quad \dots 9.4.16$$

(where \hat{x} is the unit vector along the direction of charge flow along l .)

i.e. $-\hat{i} = \hat{x} \times \hat{k}$ and therefore

$$\hat{x} = -\hat{j} \text{ (by cross product rule)}$$

Hence induced current in **ab** is from **b** to **a** and clockwise in the loop.

To maintain this current work has to be done on **ab** at the rate $F\theta = I\ell B\theta$, as obtained in eq. 9.4.9.

Here the **induced emf** and hence induced current in the loop are **due to the change in area** of the loop with time in the uniform magnetic field \vec{B} .

Example 9.4.1

A 1m long metal wire of resistance 4Ω moves perpendicular to its length at the rate of 3.5 m/s in a uniform magnetic field of 0.455T that exists in a vertical direction. Find the induced emf in the rod and the induced current if the ends of the wire are connected to the ends of a U shaped conductor of negligible resistance.

Solution

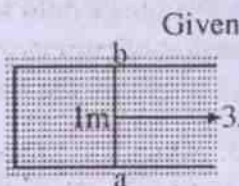

Given

$$\ell = 1\text{m}$$

$$v = 3.5 \text{ m/s}$$

$$B = 0.455\text{T}$$

$$\theta = 90^\circ$$

$$R = 4\Omega$$

$$\therefore \varepsilon = B\ell v \sin \theta = 0.455 \text{ T} \times 1\text{m} \times 3.5 \frac{\text{m}}{\text{s}} \times \sin 90^\circ = 1.6\text{V}$$

$$I = \frac{\varepsilon}{R} = \frac{1.6\text{V}}{4\Omega} = 0.4\text{A}$$

Example 9.4.2

A rod of 20 cm lying along horizontal east-west direction falls freely from the roof of

a building of height 3m. If the horizontal component of earth's magnetic field is 0.36 gauss over the region, find the rate at which the rod cuts magnetic flux in the region and the magnitude of induced emf when it reaches the bottom of the building. ($g=10 \text{ m/s}^2$ at the place)

Solution

The horizontal magnetic field of the earth $= B_H$
 $= 0.36 \times 10^{-4}$ Tesla in north south dirn.

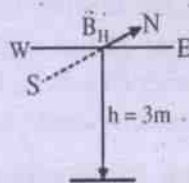

The rod falls \perp to B_H in a vertical plane. Hence it cuts magnetic flux due to B_H alone.

The vertical component of earth's magnetic field does not affect its motion.

Given that $\ell = 20 \text{ cm} = 0.2\text{m}$.

$$B_H = 0.36 \text{ gauss} = 0.36 \times 10^{-4} \text{ T}$$

$$h = 3\text{m}$$

If the rod attains a velocity v as it reaches the bottom

$$\text{then } v = \sqrt{2gh} = \sqrt{2 \times 10 \frac{\text{m}}{\text{s}^2} \times 3\text{m}} = 7.75 \text{ m/s}$$

\therefore The rate at which flux is cut by the rod

$$= \frac{d\phi}{dt} = B_H v \ell = 0.36 \times 10^{-4} \text{ T} \times 7.75 \frac{\text{m}}{\text{s}} \times 0.2\text{m} = 0.56 \text{ weber/s}$$

\therefore magnitude of induced emf produced in the rod

$$= \left| \frac{d\phi}{dt} \right| = 0.56 \frac{\text{W}}{\text{S}} = 0.56 \text{ volt}$$

9.5 Induced electric field

Let us recall Faraday's experiments described in 9.1. There we have seen that induced current is produced in a conducting loop by keeping it in a changing magnetic field \vec{B} . The changing magnetic field causes an electric field \vec{E}_n to be developed within the

conductor. This electric field makes the free electrons move within the conductor to produce current. Such an **electric field is of nonelectrostatic origin** as it is not produced by any charge. It is **non conservative** in nature. No electric potential can be defined for it. It is called an "Induced electric field" \vec{E}_n . The lines of force of such induced field are closed curves. They donot have any starting nor terminating point. The line integral of \vec{E}_n around the loop becomes the induced e.m.f. ε developed within it i.e.

$$\varepsilon = \oint \vec{E}_n \cdot d\vec{\ell} \quad \dots 9.5.1$$

Using Faraday's law of electromagnetic induction

$$\varepsilon = -\frac{d\phi}{dt}, \text{ so that}$$

$$\oint \vec{E}_n \cdot d\vec{\ell} = -\frac{d\phi}{dt} \quad \dots 9.5.2$$

The presence of a conducting loop is not necessary to have the induced electric field \vec{E}_n . \vec{E}_n is present so long as \vec{B} goes on changing. We shall get induced current if the loop remains in \vec{E}_n .

It is to be noted that electric potential has no meaning for electric fields associated with induction.

9.6 Eddy current

We have seen that there is induced current in a closed conducting loop if the loop is moved into a magnetic field or is taken out of it. The same thing happens if the loop is replaced by a solid bulk of material like a metallic plate or a disc. In such cases a number of induced current loops develop within the conductor when the entire bulk of material or a part of it moves into a magnetic field or is taken out of the field. In other words induced current loops

develop within the bulk if the magnetic flux linked with the area enclosed by each loop changes with time. such current is called eddy current or Foucault current. It is an induced current and may develop along a number of closed paths inside the bulk (fig. 9.8).

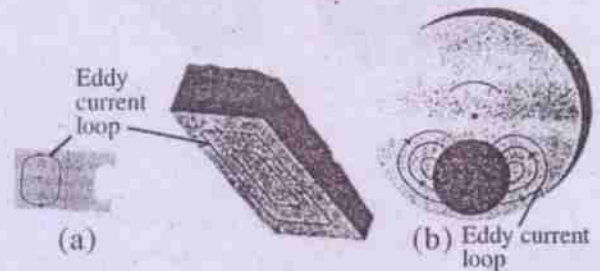

Eddy current loops in
(a) solid blocks moving in a magnetic field,
(b) disc rotating in a magnetic field

Fig. 9.8

As thermal energy is bound to be dissipated in each current loop, the entire conducting bulk of material gets heated by eddy currents.

In electrical equipments like motor and transformer development of eddies within masses of metal moving in a magnetic field generates unnecessary heat in the equipment. It is undesirable.

In some electrical measuring instruments the coil is wound on a metal frame. The eddy currents, set up in the metal frame produce damping which prevents oscillation and makes the instrument a dead beat type. The principle is used in electromagnetic brakes and dead beat galvanometers.

In situations, where eddy current is undesirable, laminated metal plates are used (fig. 9.9a) (in stead of solid pieces of metal) or slots are cut in a plate (fig. 9.9b). This prevents closed electrical paths to be formed within the body so that eddies donot develop.

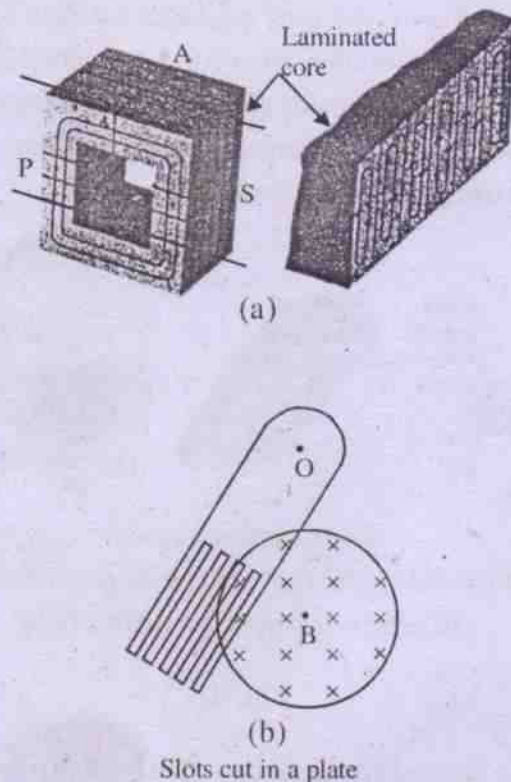

Fig. 9.9 Reduction of eddy currents by the use of (a) laminated core (b) cutting of slots

9.7 Self induction

Self induction is the phenomenon by which induced emf is generated in a conducting loop or coil due to the change of its own current with time. This is because, the current carrying loop/coil produces its own magnetic field and hence embraces magnetic flux. When the current changes, the magnetic field changes which results in a change in the magnetic flux of the loop/coil. The time rate of change of this magnetic flux develops induced emf in the coil. It is called the self induced emf. By nature this emf opposes the cause producing it i.e. it opposes the increase or decrease of current by developing a new current in the opposite direction during the time of change.

The magnetic field \vec{B} at any point due to a current I is proportional to the current. Hence the magnetic flux ϕ through the area bounded

by the loop/coil is proportional to I i.e.

$$\begin{aligned}\phi &\propto I \\ \Rightarrow \phi &= LI \quad \dots 9.7.1\end{aligned}$$

where L is a constant depending on the geometry and material of the coil, and the system of unit, used. L is called the *self inductance* of the coil.

From eq. 9.7.1, $\phi = LI$ when $I = 1$ unit of current.

Hence *self inductance of a loop/coil is defined as the magnetic flux linked through it due to unit current in it.* Its value depends on the units in which ϕ and I are measured.

The rate of change of magnetic flux linked by the coil is given by $\frac{d\phi}{dt}$ and from eq. 9.7.1

$$\frac{d\phi}{dt} = L \frac{dI}{dt} \quad \dots 9.7.2$$

Hence the induced emf ε in the coil is written as

$$\varepsilon = -\frac{d\phi}{dt} = -L \frac{dI}{dt} \quad \dots 9.7.3$$

when $\frac{dI}{dt} = 1$ unit, $\varepsilon = L$ numerically.

In other words *the self inductance of the coil is defined as the induced emf generated in the coil due to unit rate of change of current in it.*

From eq. 9.7.1 $L = \frac{\phi}{I}$, so that the unit of self inductance is *weber/ampere* i.e. W/A. From

$$9.7.3 \quad \varepsilon = L = \frac{\varepsilon}{\left| \frac{dI}{dt} \right|}, \text{ so that the unit of self}$$

inductance is $\frac{\text{volt} \cdot \text{sec}}{\text{ampere}} = \text{ohm} \cdot \text{sec}$. Thus *weber/ampere = ohm. sec.* and it is called *henry* which

is the S.I. unit of self inductance L.

The *dimension* of L is $M^1L^2T^{-2}A^{-2}$, which may be verified.

For most applications, henry (H) is rather a large unit, so that its submultiples are used. The submultiple units are millihenry (mH), microhenry (μH) etc.

$$1 \text{ mH} = 10^{-3} \text{ H and } 1 \mu\text{H} = 10^{-6} \text{ H.}$$

The role of inductance is analogous to that of inertia in mechanics.

Inertia is the property of a material body and it opposes any change in the velocity of the body. Similarly self inductance of a coil is the property of the coil and it opposes any change of current in the coil.

Even a straight wire has inductance, since a current in a wire contributes to the magnetic flux linked with a circuit of which the wire is a part.

Example 9.7.1

The current in a coil of 325 turns is changed from zero to 6.32 amp. thereby producing a flux of 8.46×10^{-4} weber. Find the self inductance of the coil.

Solution

$$\text{Given that } N=325$$

$$\Delta I = 6.32 \text{ A} - 0 = 6.32 \text{ A}$$

$$\Delta \phi = 8.46 \times 10^{-4} \text{ weber}$$

We have for N turn of coil $N\Delta\phi = L\Delta I$, so that

$$L = \frac{N\Delta\phi}{\Delta I} = \frac{325 \times 8.46 \times 10^{-4} \text{ weber}}{6.32 \text{ ampere}}$$

$$\Rightarrow L = 435 \times 10^{-4} \text{ henry} = 4.35 \times 10^{-2} \text{ henry}$$

$$= 43.5 \text{ millihenry.}$$

Example 9.7.2

A circuit in which there is a current of 2.5A is changed so that the current, falls to zero in 0.2 sec. If an average emf of 200 V is induced in the circuit, find its self inductance.

Solution

$$\text{Given that } \Delta I = 2.5 \text{ A} - 0 = 2.5 \text{ A}$$

$$\Delta t = 0.2 \text{ S}$$

$$\varepsilon = 200 \text{ V}$$

$$\therefore \varepsilon = -L \frac{\Delta I}{\Delta t},$$

$$L = \left| -\frac{\varepsilon}{\frac{\Delta I}{\Delta t}} \right| = \frac{200 \text{ V}}{\frac{2.5 \text{ A}}{0.2 \text{ S}}}$$

$$= \frac{200 \times 0.2 \text{ V.S}}{2.5 \text{ A}} = 16 \text{ H}$$

Inductor

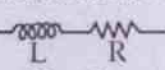
An electric circuit element having appreciable self inductance is called an inductor. In a circuit it is indicated by the symbol . An ideal inductor has zero resistance. But practically it is not so. Every real inductor has some resistance. Symbolically it is represented as . An inductor does not have any effect in a circuit in which there exists a steady current. However, it provides an opposing effect whenever the circuit current is changed. It produces unnecessary heat in the circuit. Hence coils are made noninductive by special designs (fig 9.10). Here the resistance wire is doubly wound on itself. Each turn remains very close to a similar turn carrying current in opposite direction. The magnetic flux produced by current in one half neutralises that due to current in the other half. This makes the self inductance of the coil nearly zero.

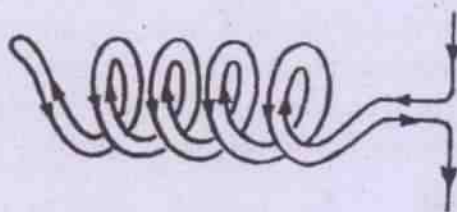

Fig. 9.10 Non-inductive coil
(Resistance wire doubly wound on itself)

Self inductance of a long solenoid

Suppose, we have a long solenoid of radius r and n turns per unit length. If I is the current through the solenoid at the instant t the magnetic field \vec{B} inside it is given by

$$|\vec{B}| = \mu_0 n I.$$

Then the instantaneous magnetic flux linking each turn of the solenoid =

$\phi = \int \vec{B} \cdot d\vec{s} = \mu_0 n I \cdot \pi r^2$. If the flux changes with time due to change of current the induced emf generated in each turn is given by

$$-\frac{d\phi}{dt} = -\mu_0 n \pi r^2 \frac{dI}{dt} \quad \dots 9.7.4$$

Hence the net emf across a length l of the solenoid is given by

$$\varepsilon = -(nl)\mu_0 n \pi r^2 \frac{dI}{dt} \quad \dots 9.7.5$$

$$\text{i.e. } \varepsilon = -(\pi \mu_0 n^2 l r^2) \frac{dI}{dt} = -L \frac{dI}{dt} \quad \dots 9.7.6$$

$$\text{i.e. } L = \pi \mu_0 n^2 l r^2 \quad \dots 9.7.7$$

Where L is the *self inductance* of the solenoid.

It is seen that the self inductance depends on the geometry of the solenoid. A coil or a solenoid made of thick wire has negligible resistance but its self inductance may be large.

Unit of μ_0

From eq. 9.7.7 we may write

$$\mu_0 = \frac{L}{\pi r^2 l n^2} \quad \dots 9.7.8$$

In the R.H.S. of eq. 9.7.8. SI unit of L , r^2 , l , n^2 are henry, (metre)², metre and (per metre)² respectively. This gives unit of μ_0 , the magnetic permeability, to be expressed as *henry per metre* or simply H/m.

Experimental demonstration of self inductance

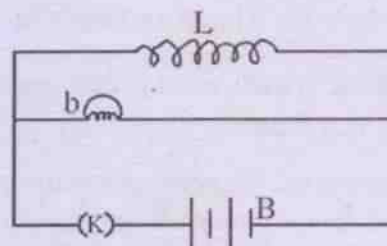

Fig. 9.11 Arrangement for demonstration of self inductance

We may demonstrate the effect of self inductance from the simple experimental arrangement shown in fig 9.11. Here L and b represent respectively an inductive coil and an ordinary bulb having a filament. L and b are connected in parallel and the combination is connected to a battery B . A Key K as shown in the figure.

On closing the key it is seen that the bulb glows brightly for a moment and then glows normally. Similarly while switching off the circuit it again glows brightly for an instant and then stops glowing. In both the cases it is due to the momentary high rate of increase or decrease

of magnetic flux $\frac{d\phi}{dt}$ through the coil so that appreciable back emf is produced in it. The bulb glows brightly under the effect of this back emf.

Energy stored in an inductor

A coil or a solenoid of thick conducting wire has negligible resistance but appreciable self inductance. Such a coil is called an inductor ($\text{---}\text{---}\text{---}$).

When a circuit containing a d.c. source and an inductor (fig. 9.12) is switched on, the current in it does not come to steady value I

immediately. There is a small time lag. This is due to the back emf ($-V_L$) produced by the inductor. The source has to do work to overcome this back emf and establish the current. This requires a small time interval. The current and its associated magnetic field build up to their steady values during the interval, which is of the order of some fraction of a second. Work W , done by the source during the interval, is stored as magnetic energy in the inductor. Let us calculate it.

Let i be the instantaneous current at a time t when the current is building up. The back emf

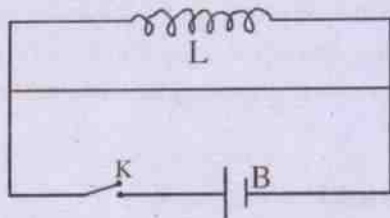

Fig. 9.12 An inductive circuit

$-V_L$ produced in the inductor at the moment is

$$-L \frac{di}{dt}$$

$$\text{i.e. } V_L = L \frac{di}{dt}$$

\therefore Work dW done by the source of emf to overcome the back emf and maintain the charge flow is given by

$$dW = V_L idt$$

$$= L \frac{di}{dt} \cdot idt$$

$$\text{i.e. } dW = L i di$$

If t_0 is the time required for the current to come to its steady value I , work W done during it is

$$W = \int_0^w dW = \int_0^I L i di$$

$$\Rightarrow W = \frac{1}{2} LI^2 = U_B \quad \dots 9.7.9$$

This is stored as magnetic energy U_B in the inductor. When the circuit is switched off, the current does not come to zero immediately too because of back emf. The energy stored in the inductor is used in maintaining the current during the decay.

We can see that the dimension of $U_B = W = \frac{1}{2} LI^2$ is that of energy. Its unit is joule when L is in henry and I , in ampere.

Example 9.7.3

A current of 3A is established in a circuit containing an inductive coil of inductance 40 mH and negligible resistance by connecting it to a d.c. source of steady emf. How much energy is stored in the coil?

Solution

$$\text{Given } L = 40 \text{ mH} = 4 \times 10^{-2} \text{H}$$

$$I = 3 \text{A (final steady value)}$$

$$\therefore U = \frac{1}{2} LI^2$$

$$= \frac{1}{2} \times 40 \times 10^{-3} \text{H} \times 9 \text{A}^2$$

$$= 18 \times 10^{-2} \text{J} = 0.18 \text{Joule.}$$

9.8 Mutual Induction

Suppose we have two coils A & B placed close to each other, the terminals of A being connected to a source of emf through a key and that of B being connected to a galvanometer G (fig. 9.13). When there is a current in A, called the primary circuit P, some magnetic flux due to it links B, the secondary circuit S. Hence any change of current in A results in a change of flux in B during the change so that an induced current is produced in B. It is observed as a deflection in the galvanometer. This was discussed in detail in the experiment no. 2 of 9.1 too. The same thing happens if the source of emf and the galvanometer interchange their

positions. Hence the phenomenon is called *mutual induction*. It is the property of a pair of circuits or coils by virtue of which any change of current in one induces an emf in the other.

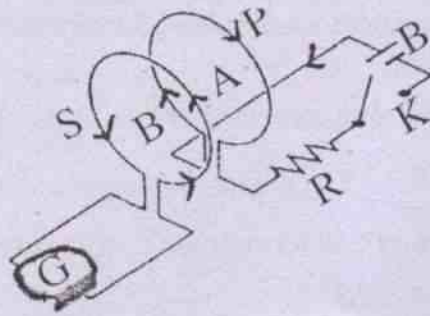

Mutual induction between two coils A and B

Fig. 9.13

If the current in the primary circuit A is I_p at any instant of time and the magnetic flux linked with B is ϕ_s due to I_p , then

$$\phi_s \propto I_p$$

$$\text{i.e. } \phi_s = MI_p \quad \dots 9.8.1$$

Where M is a constant depending on the geometrical shapes of the two circuits and their placing. M is called *mutual inductance* or the *coefficient of mutual induction* of the given pair of circuits. In eq. 9.8.1, ϕ_s denotes the total magnetic flux linked with all the turns in the coil B. When I is one unit of current i.e. 1 ampere in eq. 9.8.1, we have $\phi_s = M$. Hence we may define *mutual inductance of the two coils as the magnetic flux linked with one (i.e. the secondary) due to unit current in the other (i.e. the primary)*. As discussed in 9.7, the unit of M is weber/ampere or henry.

Further we see that if the current I in one of the circuits changes with time, there is rate of change of flux through the area bounded by the other and an emf ε is induced in it. Using Faraday's law of electro magnetic induction we

have $\varepsilon = -\frac{d\phi}{dt}$ and using eq. 9.8.1

$$\varepsilon = -M \frac{dI}{dt} \quad \dots 9.8.2$$

$$\text{This gives } M = \left| \frac{\varepsilon}{\frac{dI}{dt}} \right| \quad \dots 9.8.3$$

so that, the mutual inductance of two circuits/coils is the induced emf produced in one due to unit rate of change of current in the other.

From eq. 9.8.3 unit of M is obtained as volt. second/ampere or ohm. second, which is also called henry. *One henry is the mutual inductance of that pair of circuits in which a rate of change of current of 1 A/s in the primary causes an induced emf of 1 volt in the secondary or viceversa*. The dimension of M is $M^1L^2T^{-2}A^{-2}$.

Example 9.8.1

The current in a coil changes at 0.03 A/s. Find the mutual inductance between this coil and a nearby coil in which an emf of 0.3 mv is induced.

Solution

$$\text{Given } \frac{dI}{dt} = 0.03 \text{ As}^{-1}$$

$$\varepsilon = -0.3 \text{ mv} = -0.3 \times 10^{-3} \text{ V}$$

$$\therefore M = \frac{|\varepsilon|}{\frac{dI}{dt}} = \frac{0.3 \times 10^{-3} \text{ volt}}{0.03 \text{ ampere / sec}}$$

$$= 10^{-2} \text{ ohm.sec}$$

$$= 10 \text{ millihenry.}$$

Mutual inductance of two co-axial solenoids

Suppose we have two co-axial solenoids S_1 , and S_2 having radii r_1 , and r_2 respectively ($r_1 < r_2$). S_1 is placed inside S_2 (fig 9.14). Let n_1 and n_2 be the number of turns per unit length of

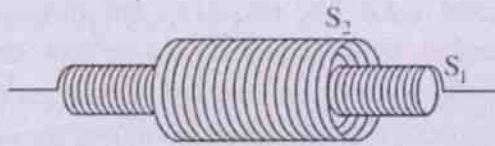

Two co-axial solenoids S_1 and S_2

Fig. 9.14

S_1 and S_2 respectively. If there is a current I in the inner solenoid S_1 , the magnetic field produced inside it is given by eq. 8.8.6 as :

$$B = \mu_0 n_1 I$$

and that outside it is zero. Though the area of each turn of the secondary is πr_2^2 , magnetic flux is linked by a portion of this area i.e. πr_1^2 which remains inside the 1st solenoid. Hence the magnetic flux associated with each turn of the secondary due to the current in the primary is equal to $B\pi r_1^2$ or $\mu_0 n_1 I \pi r_1^2$. Considering a length l of the secondary, the flux ϕ linked by all the turns within this length is given by

$$\begin{aligned} \phi &= \mu_0 n_1 I \pi r_1^2 n_2 \ell \\ \Rightarrow \phi &= (\mu_0 n_1 n_2 \pi r_1^2 \ell) I \quad \dots 9.8.4 \end{aligned}$$

Comparing eq. 9.8.4 with eq. 9.8.1, we have

$$M = \mu_0 n_1 n_2 \pi r_1^2 \ell \quad \dots 9.8.5$$

Example 9.8.2

A long air core solenoid has an area of cross section of 200 cm^2 and is wound with 40 turns per centimeter. A short coil of 300 turns is wound around the solenoid at the middle. Find the mutual inductance of the combination. If the solenoid current changes at the rate of 5 A/S , what is the emf induced in the 300 turn coil ?

Solution

Here it is given that

$$n_1 = 40 \text{ cm}^{-1} = 40 \times 100 \text{ m}^{-1}$$

$$\pi r_1^2 = 200 \text{ cm}^2 = 200 \times 10^{-4} \text{ m}^2$$

$$n_2 \ell = 300$$

$$\frac{dI_P}{dt} = 5 \frac{\text{A}}{\text{S}}$$

$$\therefore M = \mu_0 n_1 (\pi r_1^2) (n_2 \ell)$$

$$= 4\pi \times 10^{-7} \frac{\text{W}}{\text{A.m}} \times 40 \times 100 \text{ m}^{-1}$$

$$\times 200 \times 10^{-4} \text{ m}^2 \times 300$$

$$= 3 \times 10^{-2} \frac{\text{W}}{\text{A}} = 0.03 \text{ H}$$

$$\epsilon_s = -M \frac{dI_P}{dt} = -0.03 \text{ H} \times 5 \frac{\text{A}}{\text{S}}$$

$$= -0.15 \frac{\text{W}}{\text{A.S}}$$

$$= -0.15 \text{ volt.}$$

Mutual inductance is of importance in calculations involving transformer coils, dynamo apparatus, induction coils and other electric machinery. Let us discuss here how an induction coil works.

Induction coil

Induction coil is a device used to produce a large emf using a source of low emf. One such coil is Ruhmkorff's coil (fig. 9.15). It works on the basis of mutual induction. The device consists of a primary coil P wound over

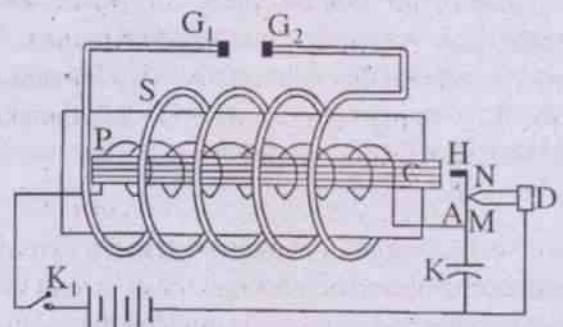

Fig. 9.15 Ruhmkorff's induction coil

a laminated soft iron core C and a secondary coil S wound co-axially over the primary. The

radius r_s of the secondary is more than r_p , the radius of the primary. The two ends of the secondary are connected to two rods G_1 and G_2 . The separation between the two rods is adjustable.

The primary coil is connected to the terminals of a battery through a circuit interrupter. In this arrangement one end of the primary is connected to a thin metallic strip M to which is attached a light soft iron hammer H (fig. 9.15). H lies close to C. The pointed end of a screw just touches M while the screw head N is connected to one terminal (-ve) of the battery. The strip M with the hammer H acts as the circuit interrupter. A capacitor k is connected in parallel between M and D. The other end of the primary is connected to the second terminal (+ve) of the battery through a switch K' .

Suppose the screw N touches the metallic strip M at one point of time. The primary circuit is completed and a current I is established in it. The current grows gradually and slowly because of the self inductance of the primary coil. The core C becomes magnetized and it attracts the hammer H. Hence the contact between M and N is broken. Here the current drops to zero but takes some time too. However, the rate of decrease of I is comparatively high in comparison with its rate of growth when the circuit is made. Now the soft iron core C becomes demagnetized and hence M with H comes to its original position. The screw now touches M and current is established again. C becomes magnetized and attracts M so that the circuit is broken again. The process of make and break of the circuit continues till the switch K' is made off.

During the change of primary current at the time of make and break of its circuit the magnetic flux linked with the secondary changes with time. Hence induced emf is developed between its ends. It appears between the rods G_1 and G_2 . This induced emf is proportional to

dI/dt . It is more at the time of break than at the time of make. The two emf's are in opposite directions. With suitable separation between the rods G_1 and G_2 one can see sparks jumping from one rod to the other. E.m.f's of the order of around 50000 volts can be produced in this way out of 12 volt of input emf in the primary circuit. Such high emf between the rods G_1 and G_2 is used to operate equipments like discharge tube, sodium vapour lamp, mercury vapour lamp etc.

Role of Capacitor

At the time of make and break of the primary circuit self induced emf is also produced between the ends of the primary along with the mutually induced emf across the secondary. The self induced emf across the primary coil at the time of break of the circuit is in the same direction of applied emf and is much larger than the applied emf. It tends to drive large current in the same direction as the original current. A large potential difference therefore appears between the screw N and the strip M. This may cause sparks to jump and the current to continue in the same direction. This reduces the rate of decay of current there by reducing the emf across the secondary. Moreover, repeated sparks between M and N may damage the surfaces too. To avoid it the capacitor K provides an alternative path to the current when the circuit is broken. The current charges the capacitor plates. Hence spark across M and N is avoided and the current in the primary circuit drops more quickly. This makes the induced emf across the secondary larger. Further, the charged capacitor is quickly discharged by sending a current in the primary circuit in the opposite direction.

9.9 E.m.f. induced in a rotating coil

In all our discussions made so far we have seen, that induced emf is developed in a conductor or in a coil either by changing the area \bar{A} associated with the coil or by varying

the magnetic field \vec{B} in which the coil is placed. There is a third way in which such emf can be generated in the coil by varying θ as indicated in eq. 9.2.7. Here θ represents the angle between the normal to the area A of the coil and the direction of \vec{B} (fig. 9.16). This is done by rotating a coil of fixed area and fixed number of turns in a uniform magnetic field \vec{B} . As the coil rotates, the flux associated with it changes continuously with time and an emf is induced in it. The emf is found to be alternating in nature.

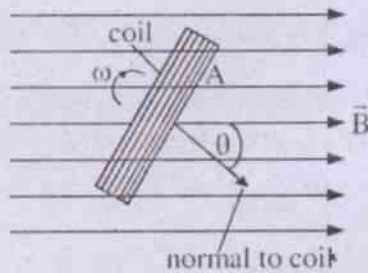

A coil of area \vec{S} lying in the magnetic field \vec{B} and making angle θ with \vec{B}

Fig. 9.16

Let us take a conducting coil of N turns, each having area S . Let it be rotated about its axis lying in its plane with constant angular speed ω in a uniform magnetic field \vec{B} . Let us assume that initially the plane of the coil is perpendicular to \vec{B} (fig 9.16). In time t , it will rotate through $\theta = \omega t$. At this position the angle between the area vector \vec{S} and \vec{B} is equal to θ and the instantaneous magnetic flux ϕ , linked with the coil is given by

$$\begin{aligned} \phi &= N\vec{S} \cdot \vec{B} = NSB \cos \theta \\ &= NSB \cos \omega t \quad \dots 9.9.1 \end{aligned}$$

Hence the instantaneous rate of change of flux is given by

$$\frac{d\phi}{dt} = -NSB\omega \sin \omega t \quad \dots 9.9.2$$

using Faraday's law of electromagnetic induction, the instantaneous emf induced in the coil is

$$\epsilon = -\frac{d\phi}{dt} = -NSB\omega \sin \omega t \quad \dots 9.9.3$$

This shows that the induced emf ϵ varies sinusoidally with time. It is maximum when $\theta = \omega t = 90^\circ$ or $\pi/2$ i.e. when the coil lies parallel to \vec{B} . This maximum emf is given by

$$\epsilon_0 = NSB\omega \quad \dots 9.9.4$$

so that eq. 9.9.3 may be written as

$$\epsilon = \epsilon_0 \sin \omega t \quad \dots 9.9.5$$

The variation of ϵ with ωt is shown graphically in Fig. 9.17b. The relative orientations of the coil with \vec{B} for some given points in the graph are shown in fig. 9.17a.

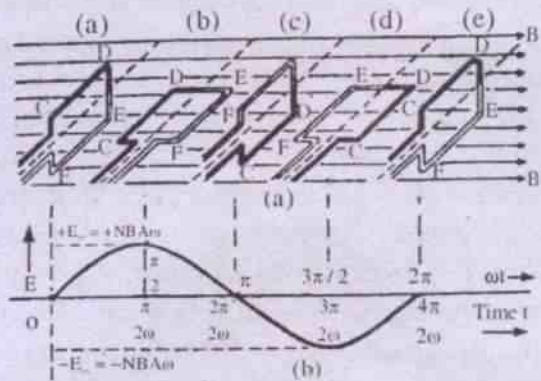

a- Orientations of coil C with B during rotation
b- Variation of ϵ with ωt for different orientation

Fig. 9.17

It is seen from the graph (fig. 9.17b) that ϵ changes sign in each half cycle of rotation. In each +ve half cycle it passes through +ve maximum of $NSB\omega$ or ϵ_0 and in each -ve half cycle it passes through a -ve maximum $-NSB\omega$ or $-\epsilon_0$. The value of the emf is repeated after a periodic time $T = \frac{2\pi}{\omega}$, in which a complete

rotation of the coil takes place. The emf given by eq. 9.9.5 is called alternating emf. It is so called because its magnitude changes at every instant and its sign changes after each half cycle of rotation. A *dynamo* or a.c. generator works on this principle. Such a source is the cause of *alternating current (a.c.)* in an external circuit connected to it. Let us discuss its construction and working.

The Dynamo or A.C. Generator

A simple diagram of a dynamo is given in Fig. 9.18. Its main components are

- (i) the field magnet,
- (ii) the armature,
- (iii) the slip rings and
- (iv) the brushes.

The *field magnet* may be a permanent magnet (fig. 9.18) or an electromagnet. The poles of the magnet face each other so that a strong, uniform field \vec{B} exists in the space between them.

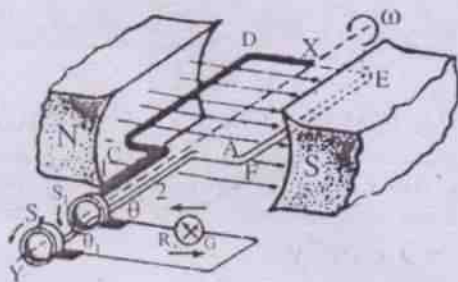

Fig. 9.18

Schematic diagram of an A.C. Dynamo

The *armature* is a coil of several turns in series. It is generally wound over a laminated soft iron core to embrace more magnetic flux. Eddy current in the core is avoided by this too. The two ends are connected to two metallic slip rings which can rotate with the coil.

The *slip rings* are rigidly fixed to the shaft but are well insulated from it. These are fixed co-axially with the axis of rotation.

The *carbon or graphite brushes* bear on the rings and can make connection to outside circuit. The brushes do not rotate with the rings.

Working

Suppose the armature of area A and number of turns N remains vertically with the direction of B initially i.e. at $t=0$. In time t it rotates by $\theta = \omega t$ where ω is its uniform angular velocity of rotation. As described earlier, the instantaneous flux linked by the armature is given by eq. 9.9.1

$$\text{i.e. } \phi = NBS \cos \omega t$$

Hence the instantaneous induced emf ε in the coil at time t is given by eq. 9.9.5.

$$\varepsilon = \varepsilon_0 \sin \omega t$$

$$\varepsilon_0 = NBA\omega$$

Which has been derived earlier (vide eqs. 9.9.1 to 9.9.5). The variation of ε with time has been shown graphically in Fig. 9.17. It is sinusoidal. When terminals of this generator i.e. the two carbon brushes are externally connected to a circuit of load R , then a sinusoidal current is established in the circuit. The current I is given by

$$I = \frac{\varepsilon}{R} = \frac{\varepsilon_0}{R} \sin \omega t$$

$$\Rightarrow I = I_0 \sin \omega t \quad \dots 9.9.6$$

$$\text{where } I_0 = \frac{NBA\omega}{R} \quad \dots 9.9.7$$

Such a current thus, varies sinusoidally with time and is called *alternating current (a.c.)*. We shall discuss its characteristics and uses in the next chapter.

It is to be noted that in some a.c. generators the armature is made stationary and the field magnet is rotated to generate the desired emf.

The D.C. Generator

Sometimes it is required to obtain unidirectional emf from a generator. This is accomplished by modifying the original generator in its construction so that the desired unidirectional emf can be fed to an external load. Here it is arranged to reverse the connections to the outside circuit at the instant when the emf changes direction in the coil. The change in connections is made by means of a commutator (fig. 9.19). The device is a split ring, each side being connected to the respective end of the coil. Brushes, usually of graphite rods, bear against the commutator as it turns with the coil. The position of the brushes is so adjusted that they slip from one commutator segment

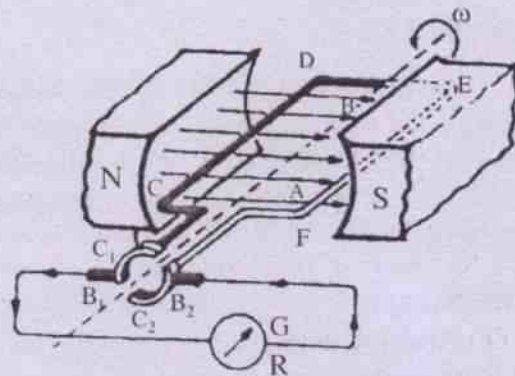
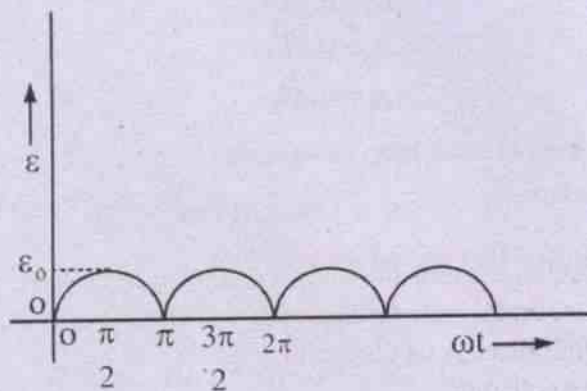

Fig. 9.19 The D.C. Generator



Variation of ϵ with ωt in a D.C. Generator

Fig. 9.20

to the other at the instant the emf changes

direction in the rotating coil. In the external circuit, there is a unidirectional voltage which is, however, not constant in magnitude. The variation of such emf with time is shown in Fig. 9.20. The curve is similar to a sine curve, with the negative half inverted. A nearly steady unidirectional emf may be obtained by using many armature coils, having their planes gradually and slightly inclined to its previous one. These are wound in slots distributed evenly around a laminated soft iron cylinder.

Example 9.9.1

A rectangular coil of 100 turns each having an area 50 cm^2 , hangs in a vertical plane with its plane perpendicular to a uniform magnetic field of $6 \times 10^{-4} \text{ T}$. If it is rotated by 90° in 0.02 sec, find the induced emf in the coil.

Solution

$$N = 100$$

$$S = 50 \text{ cm}^2 = 50 \times 10^{-4} \text{ m}^2$$

$$B = 6 \times 10^{-4} \text{ T} = 6 \times 10^{-4} \text{ W/m}^2$$

$$\Delta t = 0.02 \text{ S} = 2 \times 10^{-2} \text{ S}$$

$$\text{Initial flux linked with the coil} = \phi_1 = NSB \cos 0^\circ$$

$$\Rightarrow \phi_1 = 100 \times 50 \times 10^{-4} \text{ m}^2 \times 6 \times 10^{-4} \text{ W/m}^2$$

$$= 3 \times 10^{-4} \text{ W}$$

$$\text{Final flux linked with the coil} \phi_2 = NSB \cos 90^\circ$$

$$\Rightarrow \phi_2 = 0$$

$$\therefore \epsilon = -\frac{\Delta\phi}{\Delta t} = \frac{-(\phi_2 - \phi_1)}{\Delta t}$$

$$= \frac{-(-0 - 3 \times 10^{-4}) \text{ W}}{2 \times 10^{-2}}$$

$$= 1.5 \times 10^{-2} \text{ V}$$

$$= 15 \text{ millivolt.}$$

Miscellaneous Worked out examples

Example 9.1

Find the magnitude of induced emf in a coil of 100 turns each having area 0.32 m^2 , if the magnetic field through the coil changes by 0.40 weber/m^2 uniformly over a period of 0.04 S .

Solution

$$\text{Given } S = 0.32 \text{ m}^2$$

$$N = 100$$

$$\Delta B = 0.4 \frac{\text{W}}{\text{m}^2}$$

$$\text{and } \Delta t = 0.04 \text{ S}$$

$$\text{Then } \varepsilon = \frac{NS\Delta B}{\Delta t}$$

$$= \frac{100 \times 0.32 \text{ m}^2 \times 0.4 \frac{\text{W}}{\text{m}^2}}{0.04 \text{ S}}$$

$$= \frac{0.128 \times 10^2}{4 \times 10^{-2}} \text{ volt}$$

$$= 320 \text{ V}$$

Example 9.2

A conducting circular loop of area 1 mm^2 is placed coplanarly with a long, straight wire at a distance of 20 cm from it. The current in the wire changes from 10 A to zero in 0.1 sec . Find the average emf induced in the loop during the interval.

Solution

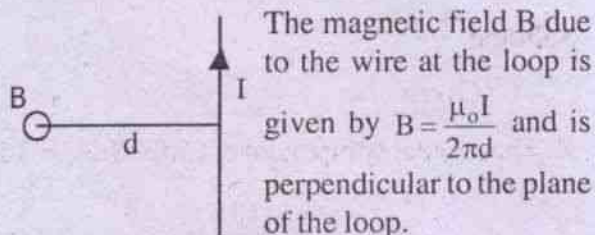

\therefore Flux through the loop

$$\phi = \frac{\mu_0 I S}{2\pi d}$$

$$\therefore \Delta\phi = 0 - \phi$$

$$= -\frac{\mu_0 IS}{2\pi d}$$

$$\therefore \varepsilon = -\frac{\Delta\phi}{\Delta t} = \frac{\mu_0 IS}{2\pi d \Delta t}$$

$$\text{Given } I = 10 \text{ A}$$

$$S = 1 \text{ mm}^2 = 10^{-6} \text{ m}^2$$

$$d = 20 \text{ cm} = 0.2 \text{ m}$$

$$\Delta t = 0.1 \text{ S}$$

$$\begin{aligned} \therefore \varepsilon &= 2 \times 10^{-7} \frac{\text{T} \cdot \text{m}}{\text{A}} \times \frac{10 \text{ A} \times 10^{-6} \text{ m}^2}{2 \times 10^{-1} \text{ m} \times 10^{-1} \text{ S}} \\ &= 10^{-10} \frac{\text{W}}{\text{S}} = 10^{-10} \text{ volt} \end{aligned}$$

Example 9.3

A circular coil of 100 turns and radius 4 cm is placed with its plane making angle 45° with a magnetic field of 0.3 T . The field reduces to 0.2 T in 0.2 S . Find the average emf induced in the loop.

Solution

$$\text{Given } N = 100$$

$$r = 4 \text{ cm} = 0.04 \text{ m}$$

$$\theta = 45^\circ$$

$$B_1 = 0.3 \text{ T}$$

$$B_2 = 0.2 \text{ T}$$

$$\Delta t = 0.2 \text{ S}$$

Area of each loop i.e. $S = \pi r^2$

$$= \pi \times 16 \times 10^{-4} \text{ m}^2$$

Initial flux linked with the coil

$$\text{i.e. } \phi_i = NSB_1 \cos\theta$$

$$= 10^2 \times \pi \times 16 \times 10^{-4} \times 0.3 \cos 45^\circ \text{ W}$$

Final flux linked with coil

$$\text{i.e. } \phi_f = NSB_2 \cos\theta$$

$$= 10^2 \times \pi \times 16 \times 10^{-4} \times 0.2 \cos 45^\circ \text{ W}$$

$$\begin{aligned} \therefore \varepsilon &= -\frac{\Delta\phi}{\Delta t} = -(\phi_f - \phi_i)/\Delta t = \frac{\phi_i - \phi_f}{\Delta t} \\ &= \frac{10^{-3} \times \pi \times 16 \times 10^{-4} \times 0.1 \cos 45^\circ}{0.2} \frac{\text{W}}{\text{S}} \\ &= \frac{8\pi}{\sqrt{2}} \times 10^{-2} \text{ volt} \\ &= 17.8 \times 10^{-2} \text{ V} = 0.178 \text{ V} \end{aligned}$$

Example 9.4

A 10 m wide space craft moves through interstellar space at a speed 3×10^7 m/s. A magnetic field of 3×10^{-10} T exists in the space in a direction perpendicular to the plane of motion. Treating the space craft as a conductor, calculate the emf induced across its width.

Solution

Given width of the space craft = $l = 10$ m

$$B = 3 \times 10^{-10} \text{ T}$$

$$v = 3 \times 10^7 \text{ m/s}$$

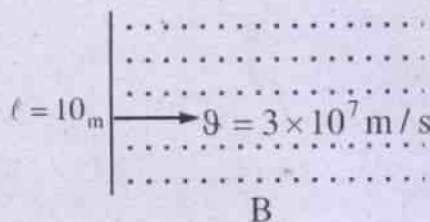

$$\begin{aligned} \therefore \varepsilon &= Blv \\ &= 3 \times 10^{-10} \text{ T} \times 10 \text{ m} \times 3 \times 10^7 \text{ m/s} \\ &= 9 \times 10^{-2} \frac{\text{W}}{\text{S}} = 0.09 \text{ V} \end{aligned}$$

Example 9.5

A copper wire bent in the shape of a semicircle of radius r translates in its plane with a constant velocity v . A uniform magnetic field B exists in the direction perpendicular to the plane of the wire. Find the emf induced between the ends of the wire if the velocity is perpendicular to the diameter joining its free ends.

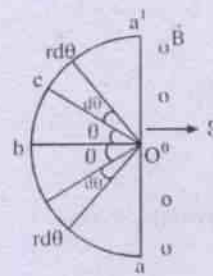

As shown in the diagram aba' is the semicircular wire. C is its midpoint. O is the centre of the circle. \vec{B} is \perp to the plane of the diagram. r is the radius of the circle.

Let us take a small arc $rd\theta$ at C , which makes angle θ with ob .

Here component of $v \perp$ to the length $rd\theta = v \sin \theta$ (from the diagram).

The motional emf $d\varepsilon_1$ induced between the ends of $rd\theta$, is given by $d\varepsilon_1 = Brd\theta v \sin \theta$

For an identical arc in the lower quadrant

$$d\varepsilon_2 = Brd\theta v \sin \theta$$

$$\therefore d\varepsilon \text{ (for the pair)} = d\varepsilon_1 + d\varepsilon_2 = 2Brd\theta v \sin \theta$$

$$\Rightarrow d\varepsilon = 2Brv \sin \theta d\theta$$

\therefore The induced emf in the wire due to its motion

$$= \varepsilon = \int d\varepsilon = \int_0^{\pi/2} 2Brv \sin \theta d\theta$$

$$\Rightarrow \varepsilon = 2Brv [-\cos \theta]_0^{\pi/2} = 2Brv$$

Example 9.6

The horizontal component of earth's magnetic field at a place is 3.3×10^{-4} T and the angle of dip is 60° . A metal rod of length 50 cm and placed along N-S direction is moved at a constant speed of 20 cm/s towards east. Find the induced emf in the rod.

Solution

Given

$$B_H = \text{horizontal component of earth's field} = 3.3 \times 10^{-4} \text{ T}$$

$$\zeta = \text{angle of dip} = 60^\circ$$

$$\therefore \tan \zeta = \frac{B_V}{B_H} \text{ (} B_V \text{ being the vertical component)}$$

$$\begin{aligned} \text{i.e. } B_v &= B_H \tan \zeta \\ &= 3.3 \times 10^{-4} \text{ T} \times \tan 60^\circ \\ &= \sqrt{3} \times 3.3 \times 10^{-4} \text{ T} \\ g &= \text{speed of the rod towards east} \\ &= 20 \frac{\text{cm}}{\text{s}} = 0.2 \text{ m/s} \\ \ell &= \text{length of the rod} = 50 \text{ cm} \\ &= 0.5 \text{ m along N-S direction.} \end{aligned}$$

As it moves perpendicular to its length i.e. towards east

$$\begin{aligned} \varepsilon &= B_v \ell g \\ &= \sqrt{3} \times 3.3 \times 10^{-4} \text{ T} \times 0.5 \text{ m} \times 0.2 \text{ m/s.} \\ &= 0.57 \times 10^{-4} \frac{\text{T} \cdot \text{m}^2}{\text{s}} \\ &= 57 \times 10^{-6} \text{ V.} \\ &= 57 \mu\text{V} \end{aligned}$$

Example 9.7

A train is travelling north with a speed of 20 m/s. The distance between the rails is 1.3 m and the vertical component of earth's field is $4 \times 10^{-5} \text{ T}$. Find the potential difference between the rails when the train is in motion. If the leakage resistance between the rails is 100 ohms, calculate the retarding force on the train.

Solution

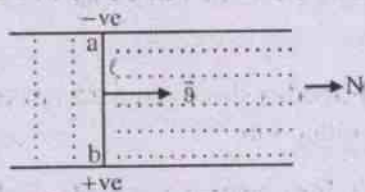

$$\text{Given } \vec{g} = \hat{i}g \text{ (say) towards north}$$

$$\ell = 1.3 \text{ m}$$

$$B_v = 4 \times 10^{-5} \text{ T}$$

$$\therefore \varepsilon \text{ (between the ends of the rod)} = B_v \ell g$$

$$= 4 \times 10^{-5} \text{ T} \times 1.3 \text{ m} \times 20 \text{ m/s} = 104 \times 10^{-5} \text{ volt}$$

$$\begin{aligned} \therefore R &= \text{the leakage resistance between the rails} \\ &= 100 \text{ ohm.} \end{aligned}$$

I = current across the rails

$$= \frac{\varepsilon}{R} = \frac{104 \times 10^{-5} \text{ volt}}{100 \text{ ohm}} = 1.04 \times 10^{-5} \text{ A}$$

\therefore The retarding force on the train

$$\begin{aligned} F &= I \ell B \\ &= 1.04 \times 10^{-5} \text{ A} \times 1.3 \text{ m} \times 4 \times 10^{-5} \text{ T} \\ &= 5.4 \times 10^{-10} \text{ newton.} \end{aligned}$$

Example 9.8

The current in an inductive circuit varies as $I = (1 - 0.2t) \text{ A}$. If the self induced emf produced in it is $2 \times 10^{-2} \text{ V}$, find the self inductance of the circuit.

Solution

$$\text{Given } I = (1 - 0.2t) \text{ A}$$

$$\therefore \frac{dI}{dt} = -0.2 \text{ A/s}$$

$$\text{i.e. } \left| \frac{dI}{dt} \right| = 0.2 \text{ A/s}$$

$$\therefore \varepsilon = L \frac{dI}{dt}$$

$$2 \times 10^{-2} \text{ V} = L \times 0.2 \text{ A/s.}$$

$$\begin{aligned} \Rightarrow L &= \frac{2 \times 10^{-2} \text{ V} \cdot \text{s}}{0.2 \text{ A}} \\ &= 0.1 \text{ H} \end{aligned}$$

Example 9.9

A metal rod of length 1 m rotates about an end with a uniform angular velocity of $\frac{\pi}{6} \text{ rad/s}$. A uniform magnetic field of 0.02 T exists in the region in a direction parallel to the axis of rotation. Find the emf induced between the ends of the rod.

Solution

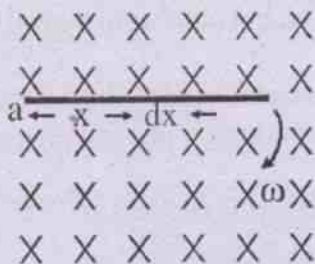

As shown in the diagram rod ab of length l (say) rotates about a with angular speed ω (say) in the plane of the diagram. The magnetic field is perpendicular to the plane of the diagram down wards. Let us take an element of length dx on the rod at a distance x from a . The linear speed of the element of length $= v = \omega x$. As it moves perpendicular to its length and also perpendicular to the magnetic field, it cuts magnetic flux at the rate $Bv dx$.

$$\text{i.e. } \frac{d\phi}{dt} = Bv dx$$

\therefore The magnitude of induced emf between the ends of the element $= d\varepsilon = Bv dx = B\omega x dx$.

\therefore The net induced emf between the ends of the

$$\text{rod} = \varepsilon = \int_0^l d\varepsilon = \int_0^l B\omega x dx$$

$$\text{i.e. } \varepsilon = \frac{1}{2} B\omega l^2$$

Given in the problem $l = 1\text{m}$

$$\omega = \frac{\pi}{6} \text{ rad/s}$$

$$B = 0.02\text{T}$$

$$\therefore \varepsilon = \frac{1}{2} B\omega l^2$$

$$= \frac{1}{2} \times 0.02\text{T} \times \frac{\pi}{6\text{s}} \times 1\text{m}^2$$

$$= 5.24 \times 10^{-3} \frac{\text{Tm}^2}{\text{s}}$$

$$= 5.24 \times 10^{-3} \text{ volt.}$$

Example 9.10

The current through a 1H inductor varies sinusoidally with an amplitude of 5A and a frequency of 50 cycles per sec. Calculate the peak potential difference across the inductor.

Solution

Let the current be given by $I = I_0 \sin \omega t$

$$\text{Then } \varepsilon = -L \frac{dI}{dt}$$

$$= -L \frac{d}{dt} (I_0 \sin \omega t) = -LI_0 \omega \cos \omega t$$

$$= \varepsilon_0 \cos \omega t$$

where $\varepsilon_0 = -LI_0 \omega$ and $|\varepsilon_0| = LI_0 \omega$

Given $L = 1\text{H}$

$$I_0 = 5\text{A}$$

$$\omega = 2\pi f = 2\pi \times 50 \text{ c.p.s.} = 100\pi/\text{s}$$

$$\therefore \varepsilon_0 = 1\text{H} \times 5\text{A} \times 100\pi/\text{s} \approx 1570 \text{ volt}$$

SUMMARY

Electromagnetic induction is the phenomenon of generating induced emf in a coil by changing the magnetic flux (ϕ) linked by the coil with time.

Michael Faraday discovered the law of electro magnetic induction.

Faraday's law states that the rate of change of total magnetic flux linked by a coil is equal in

magnitude to the induced emf in it i.e. $\varepsilon = -N \frac{d\phi}{dt}$.

Lenz's law gives the nature of induced emf and is in accordance with the principle of conservation of energy.

Lenz's law states that in all cases of electromagnetic induction the induced current is in such a direction so as to oppose the cause to which it is due.

Motional emf is the induced emf developed between the ends of a conductor when the conductor moves in the magnetic field in a direction other than the parallel or antiparallel direction. Maximum motional emf is produced when the conductor moves perpendicular to the field. It is given by $\varepsilon = B\ell v$ where B , ℓ and v stand for the magnetic field, the length of the conductor and the velocity of the conductor respectively.

The direction of motional emf and hence the induced current in a closed conducting path is given by Fleming's right hand rule.

Fleming's right hand rule states that "If the forefinger of the right hand points in the direction of magnetic field and the thumb in the direction of motion of the conductor, then the middle finger will point in the direction of induced current."

The induced current due to motional emf in a circuit of resistance R is given by $I = \frac{B\ell v \sin\theta}{R}$

Power P required to maintain velocity v in the conductor is given by $P = \frac{B^2 \ell^2 v^2}{R}$.

Induced electric field is of nonelectrostatic origin and nonconservative. It is produced by changing magnetic flux. The induced emf in terms of induced electric field \vec{E}_n is given by

$$\varepsilon = \oint \vec{E}_n \cdot d\vec{\ell} = -\frac{d\phi}{dt}$$

Eddy current loops develop within solid bulk of conductor when it is moved into a magnetic field. Such currents produce unnecessary heating in the conductor.

Self induction is the phenomenon in which induced emf is generated in a conducting loop or coil due to any change of its own current

with time. The emf induced in the coil is $\varepsilon = -L \frac{dI}{dt}$

Self inductance L of a loop/coil is the magnetic flux linked through it due to unit current in it,

i.e. $L = \frac{\phi}{I}$. It is also defined as $L = \varepsilon / \frac{dI}{dt}$. Its S.I.

unit is weber/ampere or ohm-sec which is also called henry (H).

A coil or a solenoid behaves as an inductor, given by symbol . When connected in a circuit it produces back emf at the time of change of current. In such situations energy is

stored in the inductor and is given by $U = \frac{1}{2} LI^2$,

when the current gradually builds up in the circuit from zero to I .

Mutual induction is the property of a pair of circuits or coils by virtue of which any change of current in one induces an emf in the other in

the opposite sense. The induced emf $\varepsilon_o = -M \frac{dI}{dt}$.

Mutual inductance of two coils is defined as the magnetic flux linked by one due to unit current in the other i.e. $M = \phi_s / I_p = \phi_p / I_s$.

It is also defined as the induced emf developed in the secondary due to unit rate of change of

flux in the primary, or vice versa. i.e. $M = \left| \frac{d\phi_p}{dt} \right|$.

Induction coil is a device used to produce a large emf using a source of low emf. It works on the principle of mutual induction.

Sinusoidal emf can be developed in a coil by rotating it in a magnetic field, not parallel to the plane of the coil. Such sinusoidal emf is given by $\varepsilon = \varepsilon_o \sin \omega t$, where $\varepsilon_o = NBS\omega$ where N , B , S and ω stand for no. of turns in the coil, the magnetic induction of the field, area of the coil and angular velocity of rotation of the coil respectively.

MODEL QUESTIONS

A. Multiple Choice Questions :

1. A bar magnet is moved quickly towards a closed coil of 100 turns and area 25cm^2 , its plane being parallel to the direction of motion of the magnet. The induced current produced in the coil is
 - a) zero
 - b) 0.25A
 - c) 2.5A
 - d) 4A
2. The magnitude of induced emf in a coil depends on the
 - a) the amount of magnetic flux linked by the coil.
 - b) the amount of electric flux linked by the coil.
 - c) the rate of change of magnetic flux linked by the coil.
 - d) the rate of change of electric flux linked by the coil.
3. A rod of length ℓ rotates with a small but uniform angular velocity ω about its perpendicular bisector. A uniform magnetic field of 0.3T exists parallel to the axis of rotation. The potential difference between the two ends of the rod is
 - a) zero
 - b) $0.15\ell\omega^2$
 - c) $0.3\ell\omega^2$
 - d) $0.6\ell\omega^2$
4. Weber per second is equal to
 - a) Ampere
 - b) Volt
 - c) Ohm
 - d) Henry
5. An iron rod of length 1 m moves in a magnetic field of 0.32T with a velocity of 2m/s in a direction that is perpendicular to the field. The induced emf between the ends of the rod is
 - a) 0.64 V
 - b) 0.32 V
 - c) 0.16 V
 - d) zero
6. The induced electric field produced in a region due to time rate of change of magnetic flux in a coil is of
 - a) electrostatic origin and conservative.
 - b) nonelectrostatic origin and conservative.
 - c) electrostatic origin and non conservative.
 - d) non electrostatic origin and nonconservative.
7. The current through a choke coil of inductance 0.5H is decreased at the rate of 2A/s. The induced emf developed in the coil is of magnitude
 - a) 0.25 V
 - b) 1 V
 - c) 2 V
 - d) 4 V
8. A magnet is allowed to fall from a height through a metal ring of diameter 0.5m. The acceleration of the magnet is
 - a) equal to g
 - b) less than g
 - c) greater than g
 - d) zero
9. The current in an inductive circuit changes from 0.5A to 0.3A in 2 seconds. If the self inductance of the coil is 1 mH, the induced emf developed in the circuit is
 - a) 10^{-4} V
 - b) 2×10^{-4} V
 - c) 3×10^{-4} V
 - d) 4×10^{-4} V
10. Self inductance of a coil delays
 - a) the growth of current through it.
 - b) the decay of current through it.
 - c) both the growth and decay of current through it.
 - d) neither the growth nor the decay of current through it.

11. Mutual inductance between two circuits does not depend on
- number of turns in both the coils.
 - area of both the coils.
 - permeability of the cores of the coils and permeability of the separating medium.
 - permittivity of the cores of the coils and permittivity of the separating medium.
12. Self inductance of a coil is the mechanical analogue of
- energy
 - momentum
 - inertia
 - power
13. A conducting plate is allowed to swing like a pendulum about a pivot and into a region of magnetic field. Eddy currents are induced in the plate when the conductor
- enters the field but not when it leaves it.
 - leaves the field but not when it enters it.
 - enters the field and leaves it.
 - does not enter nor leave the field.
14. A bar magnet is released from rest along the axis of a very long and vertical copper tube. After some time the magnet will
- come to rest inside the tube.
 - move with terminal velocity.
 - move with an acceleration greater than g .
 - oscillate.
15. L , C and R stand for the inductance, capacitance and resistance respectively of an LCR circuit. Which of the following expressions has the dimension of frequency?
- $\frac{L}{R}$
 - $\frac{C}{L}$
 - $\frac{1}{\sqrt{RC}}$
 - $\frac{1}{\sqrt{LC}}$
16. The unit of magnetic permeability can be written as
- henry/(meter)²
 - (meter)²/henry
 - henry/metre
 - metre/henry
17. A current of 2A is established in an inductor of inductance 1mH in 0.02 sec. The magnetic energy stored in the inductor is
- 2×10^{-3} J
 - 1×10^{-3} J
 - 4×10^{-5} J
 - 2×10^{-5} J
18. Two circular, similar and co-axial loops carry equal currents in the same direction. If the loops are brought nearer
- current will increase in each loop.
 - current will decrease in each loop.
 - current will remain the same in each loop.
 - current will increase in one and decrease in the other.
19. A coil having number of turns N and area A is rotated in a uniform magnetic field with angular velocity ω . The maximum induced emf in it is given by
- $NAB \omega$
 - $\frac{NAB}{\omega}$
 - $\frac{NA\omega}{B}$
 - $\frac{NA}{B\omega}$
20. When the number of turns in a coil is doubled without any change in the length of the coil, its self inductance L becomes
- $4L$
 - $2L$
 - $L/2$
 - L^2

B. Very Short Answer Questions :

1. Under what condition induced current is produced in a closed coil ?
2. Explain the symbols used in the expression $\varepsilon = -N \frac{\Delta\phi}{\Delta t}$
3. State Lenz's law.
4. How much emf is induced in a coil of single turn when the magnetic flux linked with the coil changes by 0.5 weber in 1 sec ?
5. Define coefficient of self induction.
6. Mention two physical factors which may be varied for a coil to produce induced current in it in a fixed magnetic field.
7. A straight conductor is moved in a magnetic field in a direction parallel to the field. How much emf is induced between the ends of the conductor ?
8. Define coefficient of mutual induction.
9. Define self inductance of a coil.
10. Can you have an inductor without any resistance ?
11. How much induced emf is developed in a circuit containing an inductance of one millihenry if there is a steady d.c. of 0.1A maintained in the circuit ?
12. Mention the name of two factors that govern the magnitude of induced emf in an electric circuit.
13. The electric mains in the house is marked 220V, 50 c.p.s. Write down the equation for instantaneous voltage.
14. Name the device that converts a.c. to d.c. in a dynamo.
15. Name the quantity measured in Maxwell/cm.
16. Give the relation between weber and maxwell.
17. Name the unit of self inductance in S.I. system.
18. Write the dimension of mutual inductance.
19. Name the rule to determine the direction of induced emf in a conductor.
20. Mention two uses of eddy current.
21. Name the essential parts of a dynamo.
22. Define henry. [CHSE, 1989(S)]
23. What will happen if a closed coil is placed in a changing magnetic field ?
[CHSE, 1991(S)]
24. State Fleming's right hand rule.
[CHSE, 1993(S)]
25. Name the principle on which a dynamo works.
26. What emf is developed in a coil that moves through a uniform magnetic field.
27. Write the S.I unit of magnetic flux. Is it a scalar or a vector quantity ?
[CHSE 2003]
28. How does the self-inductance of air coil change, when (i) the number of turns in the coil is decreased (ii) an iron rod is introduced in the coil. [CHSE 2003]
29. If the number of turns in the solenoid is doubled, keeping other factors constant, how does the self-inductance of the coil change ? [CHSE 2000]
30. If the rate of change of current 2 ampere/second induces an emf of 40 mV in the solenoid, what is the self-inductance of this solenoid ? [CHSE 1996]

C. Short Answer Questions :

1. Explain what is electromagnetic induction.
2. Write Faraday's law of electromagnetic induction and explain it.

3. Explain motional emf.
4. Write down the mathematical expression for motional emf and explain the symbols there in.
5. Why does a spark appear in the switch of a fan when it is put off ?
6. Explain what is self induction.
7. Explain what is mutual induction.
8. How does Lenz's law obey the principle of conservation of energy ?
9. Establish the S.I. unit of self induction.
10. How does a dynamo differ from a motor ?
[CHSE, 1986(S)]
11. State Lenz's law and explain it.
[CHSE, 1987 (S)]
12. Explain Fleming's right hand rule.
[CHSE, 1988(S)]
13. Define coefficient of self induction and state its units.
14. The magnetic induction inside a solenoid is $\mu_0 nI$ and is parallel to its axis. The cross sectional area of the solenoid is A. Calculate the value of its self inductance.
[CHSE, 1994(A)]
15. Distinguish between self induction and mutual induction.
16. Distinguish between a resistance and an inductance.
17. Why are the coils in a resistance box doubly wound ?
18. Explain the factors on which the coefficient of mutual induction depends.
19. Why is the induced emf stronger when the current in an L.R. circuit is cut off than when it is made on ?
20. What happens to M if the number of turns in the secondary coil is increased without affecting the primary circuit.
21. How much power is required to drag a rectangular coil through a magnetic field so long as the coil remains inside the field ?
22. How does self induction play the role in bringing an oscillating galvanometer to rest ?
23. Explain what happens when a circular coil and a bar magnet recede from each other with the same speed.
24. A bar magnet is kept along the axis of a circular coil. Will there be current in the coil if the magnet is rotated about its own axis ? Explain your answer.
25. A metallic loop is placed in a nonuniform magnetic field. Will an emf be induced in the loop ? Explain.
26. Why does an oscillating moving coil galvanometer come to rest immediately when its ends are connected together.
27. A pivoted aluminium bar falls much more slowly through a small region containing a magnetic field than a similar bar of an insulating material having the same weight. Explain.
28. How does the mutual conductance of a pair of coils change when (i) the distance between the coils is increased and (ii) the number of turns in each coil is decreased? Justify your answer in each case.
[CBSE 1998]
29. Two identical loops, one of copper and the other of aluminium, are rotated with the same angular speed in the same magnetic field. Compare (i) the induced emf and (ii) the current produced in the two coils. Justify your answer.
[CBSE AI 2010]

30. Two identical coils, one of radius r and the other of radius R are placed co-axially with their centres coinciding. For $R \gg r$, obtain an expression for the mutual inductance of the arrangement.

[CBSE 2004, 08]

D. Long Answer Type

- Describe Faraday's experiment on induced emf and induced current and explain how the results led to the formulation of the law of electromagnetic induction.
 - Explain what is induced emf. In what way it is different from the emf due to a battery? Mention the factors on which induced emf depends.
 - Describe how translational induced emf is produced. Find an expression for the same. Find the magnitude of induced emf in a conductor, when it moves parallel to a magnetic field.
 - Explain what is eddy current. Discuss its advantages and disadvantages. Suggest ways to minimise eddies in conducting blocks.
 - Describe how rotational induced emf is produced. Deduce $\varepsilon = \varepsilon_0 \sin \omega t$ and discuss its significance.
 - Give the principle of construction and working of an a.c. generator. How is it converted to a d.c. generator.
 - Describe the principle, construction and working of a d.c. generator. Discuss how it differs from an a.c. generator.
 - Explain what is a dynamo. Discuss with necessary theory the working of an a.c. dynamo.
 - Explain what is self induction of a circuit. Describe an experiment to demonstrate the same.
- A long straight conductor carrying a steady current passes through the centre of a circular coil, perpendicular to its plane. If the current in the straight conductor is increased suddenly, will an emf be induced in the circular coil? Explain your answer.
- It is seen that, if a permanent magnet is dropped down a vertical copper pipe, it eventually attains a terminal velocity, even if there is no air resistance. Explain the phenomenon.
 - A current carrying conductor passes through the centre of a metal ring normal to the plane of the ring. Is there a current in the ring when the current in the conductor is switched on and switched off? Will such current in the ring be seen when the current in the conductor is steady? Explain your answers.
 - A farmer claimed that the high voltage transmission lines running parallel to his wire fence induced large voltages on the fence and often becomes dangerous. Is it possible? Explain your answer.
 - A sheet of copper is placed between the poles of an electromagnet, so that the magnetic field is perpendicular to the sheet. When the sheet is pulled out, a considerable force is required and the force required increases with speed. Explain the happening.

E. Numerical Exercises

- The plane of a coil of area 100 m^2 is at right angles to a magnetic field of induction 10^{-2} weber / m^2 . If the field decreases to 5×10^{-3} weber / m^2 in 5 s, find the average induced emf in the coil.
- An aluminium disc of diameter 25 cm rotates at 3600 r.p.m. about its axis. It is placed in a magnetic field of induction 0.2T acting parallel to the axis of rotation

- of the disc. Calculate the magnitude of induced emf between the axis of rotation and the rim of the disc.
- Calculate the emf induced between the ends of an axle of length 1.75 m of a railway carriage which runs on a level ground with a uniform speed of 80 km/hour. The horizontal component of earth's magnetic field at the place of observation is 3.2×10^{-5} T and the angle of dip is 60° .
 - A horizontal straight rod of length 2m and extending along East-West falls vertically down with an average speed of 5 m/s. If the horizontal component of earth's magnetic field is 3.6×10^{-5} T, in the region find the instantaneous value of emf induced in the rod.
 - A 10 cm long wire carries a current of 5A and lies perpendicular to the field of strength 2.5 mT. Calculate the force acting on the conductor and the mechanical power required to move it against this force with a speed of 2 m/s. Find too the induced emf in the conductor.
 - A copper rod of length 1m rotates about one of its ends with an angular speed of 10π rad / s in a uniform magnetic field of 2T that is perpendicular to the plane of rotation. Calculate the induced emf developed between the two ends of the rod.
 - The current in a coil of self inductance 2H increases as $I = 2 \sin t^2$ where t stands for time. Find the amount of energy spent during a period when the current changes from zero to 2A.
 - An emf of 1.5 KV is induced in a coil when the current in it collapses uniformly from 4A to zero in 8 millisecond. Determine the self inductance of the coil.
 - A long solenoid having 220 turns /cm, carries a current of 1.5 A, its diameter being 3.2 cm. Another close-packed coil C of 130 turns and diameter 2.1 cm lies co-axially at the centre of the solenoid. Find the emf induced in C when the current in the solenoid is reduced to zero at a steady rate in 25 millisecond.
 - The current in the primary of an induction coil of mutual inductance 5H is suddenly switched off so that an emf of 30000 V is induced in the secondary. Find the current in the primary before break if it is uniformly reduced to zero in 10^{-4} s.
 - The current in a 0.25 H inductor is given by $I = 5t^2 + 7t + 3$. Find the induced emf in the inductor at $t = 2$ millisecond.
 - A fan blade of length 0.5 m rotates uniformly at right angles to a uniform magnetic field of 5 millitesla parallel to the axis of rotation. If the fan makes 1500 revolutions per minute how much potential difference is developed between the ends of the blade during rotation.
 - The current through a 0.5 H inductor varies sinusoidally with an amplitude of 2A, and frequency of 50 c.p.s. Calculate the maximum potential difference developed across the inductor.
 - A square coil of edge 20 cm and 100 turns is rotated with a uniform angular speed of $\pi/3$ rad/s about one of its diagonals which is kept fixed in a horizontal position. If a uniform magnetic field of 0.4 T exists in the vertical direction, find the maximum value of emf induced in the coil.
 - A conducting circular loop of radius 50 cm is rotated about its diameter at a constant angular speed of 6π rad / s in a magnetic field of 1 tesla that exists perpendicular to the axis of rotation. Find the maximum emf induced in the loop and the positions where the induced emf is zero.
 - A 10 m wide space craft moves through the interstellar space at a speed 3×10^4 km/s. A magnetic field of 3×10^{-8} T exists in the space in a direction perpendicular to the plane of motion.

Assuming the space craft to be conducting, find the emf induced across its width.

17. A magnetic flux of 16×10^{-4} weber is linked with each turn of a 100 turn coil when there is an electric current of 2A in it. Calculate the self inductance of the coil.
18. The current in a solenoid of 200 turns over a length of 10 cm, changes at the rate of 1A/S. If the radius of the solenoid is 2cm, find the emf induced in it and its self inductance.
19. A solenoid of length 12cm and radius 2cm has 2000 turns and it is placed inside another solenoid of the same length and same number of turns but of radius 4cm. Find the mutual inductance between the solenoids.
20. The current in a coil changes at 0.02 A/S. Find the mutual inductance between this coil and a nearby coil in which an emf of 0.4 mV is induced.
21. A small piece of metal wire is dragged across the gap between the pole pieces of a magnet in 0.5 s. The magnetic flux between the pole pieces is known to be 8×10^{-4} Wb. Estimate the induced emf in the wire. [CBSE 2004]
22. A jet plane is travelling west at 450 m/s . If the horizontal component of earth's magnetic field at that place is 4×10^{-4} T and the angle of dip is 30° , find the emf induced between the ends of wings having a span of 30 m. [CBSE AI 2008]
23. The magnetic flux linked with a large circular coil, of radius R, is 0.5×10^{-3} Wb when a current of 0.5 A, flows through a small neighbouring coil of radius r.

Calculate the coefficient of mutual inductance for the given pair of coils.

[CBSE 2008 C1]

F. Answer as directed

1. A coil of insulated copper wire is moved in a uniform magnetic field at constant rate. An emf is induced in it (True / False)
2. A coil of metal wire is stationary in a non-uniform magnetic field, will an emf be induced in the coil ? (Yes/No)
3. A wire-coil carries the current I. How will the potential energy of the coil depend upon the resistance of the coil ?
4. Is a transformer used to convert alternating current into direct current ?
5. When a magnet is moved with its north polarity towards a coil placed in a closed circuit, then what type of polarity will be found in the nearer face of the coil ?
6. Do eddy currents cause sparking ?
7. Is the self inductance of a coil a measure of electrical inertia or induced emf ?
8. A coil is rotated with a uniform speed in a constant magnetic field. Will there be induced emf and if so, can it be periodic ?

G. Correct the following sentences :

1. Fleming's left hand rule gives the direction of induced current, when a conductor moves in a magnetic field.
2. Lenz's law confirms the principle of conservation of momentum.
3. The S.I unit of self inductance is volt/ampere.
4. The dimension of mutual inductance is $\text{ML}^2\text{T}^3\text{A}^{-1}$.
5. Weber per second is equal to henry.
6. Self inductance of a coil speeds up the growth and decay of current through it.
7. Induced current is produced in a closed coil when a magnet is kept near it.

ANSWERS

A. Multiple Choice Type Questions :

1. (a) 2. (c) 3. (a) 4. (b) 5. (a) 6. (d) 7. (b) 8. (b)
 9. (a) 10. (c) 11. (d) 12. (c) 13. (c) 14. (b) 15. (d) 16. (c)
 17. (a) 18. (b) 19. (a) 20. (b)

E. Numerical exercises :

- | | |
|---|-----------------------------|
| 1. 0.1 V | 2. 0.589 V |
| 3. 0.0022 V | 4. 36×10^{-5} volt |
| 5. 1.25×10^{-3} newton, 2.5×10^{-3} watt, 5×10^{-4} volt | |
| 6. 31.4 volt | 7. 4 Joule |
| 8. 3 H | 9. 75 mV |
| 10. 0.6 A | 11. 1.755 V |
| 12. 0.0982 V | 13. 314.16 V |
| 14. 1.676 V | |
| 15. 14.804 V; $\varepsilon = 0$ at $\omega t = n\pi$ where $n = 0, 1, 2, \dots$ | |
| 16. 9V | 17. 8×10^{-2} H |
| 18. 6.32×10^{-4} V; 6.32×10^{-4} H | 19. 0.053 H |
| 20. 0.02 H | 21. 1.6 mV, |
| 22. 3.12 V, | 23. 1 mH |

- F. (1) False (2) No. (3) Does not depend on (4) No. (5) North polarity (6) No. (7) Electrical inertia (8) Yes, induced emf and is periodic.

10

Alternating Currents

We have studied the direct current (dc) circuits. In such circuits currents, voltages and emfs are treated as constants and they do not vary with time in direction and magnitude. However, large scale power generation and distribution is not easy using dc. Instead, it is achieved by alternating current (ac), in which voltages and currents vary with time, often in sinusoidal manner. These are produced by sources producing alternating emfs i.e. dynamos. In this chapter let us study the properties of ac and the circuits in which it is maintained. Many of the same principles used in dc circuits are applicable here and some new ideas relating to the behaviour of inductors and capacitors will be briefly discussed.

10.1 Alternating Current :

In the previous chapter we have seen how alternating emf is generated by a dynamo. Such an emf is given by

$$\varepsilon = \varepsilon_0 \sin(\omega t + \phi) \quad \dots 10.1.1$$

where, ε_0 = peak value or amplitude of emf

ω = angular frequency of variation of emf

and ϕ = the initial phase angle

$$\text{If } \phi = 0, \text{ then } \varepsilon = \varepsilon_0 \sin \omega t \quad \dots 10.1.2$$

When such a source of emf is connected externally to a load of resistance R (fig. 10.1)

the instantaneous current developed in the circuit is given by

$$I = \frac{\varepsilon}{R} = \frac{\varepsilon_0}{R} \sin(\omega t + \phi)$$

$$\Rightarrow I = I_0 \sin(\omega t + \phi) \quad \dots 10.1.3$$

where I is called the alternating current (ac) in the circuit

and I_0 is its peak value or amplitude

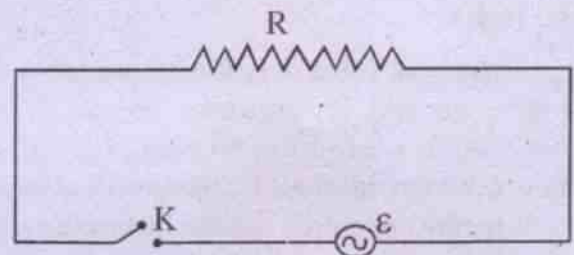

Fig. 10.1
(a.c. circuit with a load R)

Such a current varies continuously in magnitude and periodically in direction. It repeats its value after each time interval $T = 2\pi / \omega$, called the **time period** of ac. ϕ is called the initial phase angle of the sinusoidal variation. A plot of T versus t is shown in Fig. 10.2. The current is positive for half the time period and is negative for the remaining half. In each half it passes through a peak value. An a.c. source is shown as \sim in a circuit diagram.

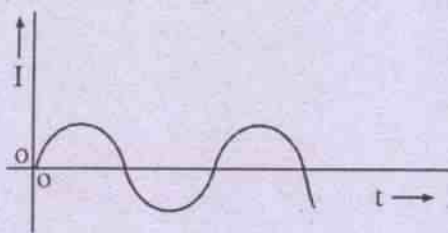

Fig. 10.2

(Variation of a.c. with time)

A sinusoidally varying emf or current can as well be represented by the equations, $\varepsilon = \varepsilon_0 \cos(\omega t + \phi)$. Such an emf or current differs from that represented by eq. 10.1.1 or 10.1.3 in the initial phase, which is $\pi/2$. One may note that the **instantaneous phase** of alternating current or voltage is measured by the angle turned through by the generating element from a given instant. Any given phase of a.c. is repeated after a periodic time $T = 2\pi / \omega = \frac{1}{f}$, where 'f' denotes the frequency of a.c.

Ex. 10.1.1 :

The peak value of emf of an a.c. source is 100 volt and its frequency 50 cps. It is connected to a resistor of 50 ohm externally. Write down the equations for instantaneous emf produced by the source and the instantaneous current assuming the initial phase angle to be zero. Find the peak value of a.c.

Soln.

$$\begin{aligned} \text{Given } \quad \varepsilon_0 &= 100\text{V} \\ f &= 50 \text{ cps} \\ \therefore \omega &= 2\pi f = 100\pi \text{ per sec.} \\ R &= 50 \text{ ohm} \end{aligned}$$

Hence the instantaneous emf is given by

$$\varepsilon = \varepsilon_0 \sin \omega t = 100 \sin 100\pi t$$

and the instantaneous a.c. I is given by

$$I = \frac{\varepsilon_0}{R} \sin \omega t = \frac{100}{50} \sin 100\pi t = 2 \sin 100\pi t$$

\therefore The peak value of current $= I_0 = 2\text{A}$

10.2 Average and effective values of alternating current

The alternating current varies sinusoidally with time and repeats its value after one time period T. Its value at any instant t is given by eq. 10.1.3. i.e. $I = I_0 \sin(\omega t + \phi)$. It is a periodic function of time. Hence we may calculate its average value either over a period T or over a half period T/2.

The **average value of a.c. over a period T** is given by

$$\begin{aligned} I_{av} &= \frac{\int_0^T I dt}{\int_0^T dt} = \frac{\int_0^T I_0 \sin(\omega t + \phi) dt}{T} \\ \Rightarrow I_{av} &= \frac{I_0}{T} \left[\frac{-\cos(\omega t + \phi)}{\omega} \right]_0^T \\ &= \frac{I_0}{\omega T} [-\cos(\omega T + \phi) + \cos \phi] \\ &= \frac{I_0}{2\pi} [-\cos(2\pi + \phi) + \cos \phi] \\ \Rightarrow I_{av} &= \frac{I_0}{2\pi} [-\cos \phi + \cos \phi] = 0 \quad \dots 10.2.1 \end{aligned}$$

$$[\because \omega T = 2\pi \text{ and } \cos(2\pi + \alpha) = \cos \alpha]$$

Thus we see that the average value of a.c. over a cycle or over a period is zero. Since the periodic time of a.c., we use, is very small i.e. a small fraction of a second, it is of no use to take its average value. On the otherhand we may calculate such average value over half a cycle i.e. over a period from 0 to T/2.

The **average value of a.c. over T/2** is given by

$$I_{av(T/2)} = \frac{\int_0^{T/2} I dt}{\int_0^{T/2} dt}$$

$$\begin{aligned}
 &= \frac{I}{T/2} \int_0^{T/2} I_0 \sin(\omega t + \phi) dt \\
 &= \frac{2I_0}{T} \left[\frac{-\cos(\omega t + \phi)}{\omega} \right]_0^{T/2} \\
 &= \frac{2I_0}{\omega T} \left[-\cos\left(\frac{\omega T}{2} + \phi\right) + \cos \phi \right] \\
 &= \frac{2I_0}{2\pi} [-\cos(\pi + \phi) + \cos \phi] \\
 &= \frac{I_0}{\pi} [\cos \phi + \cos \phi] \\
 \Rightarrow I_{av(T/2)} &= \frac{2I_0 \cos \phi}{\pi} \quad \dots 10.2.2
 \end{aligned}$$

Eq. 10.2.2. gives the I_{av} over the + ve half cycle. Such average value over the - ve half cycle can be similarly calculated as

$$\begin{aligned}
 I_{av}(\text{from } T/2 \text{ to } T) &= \frac{\int_{T/2}^T I_0 \sin(\omega t + \phi) dt}{\int_{T/2}^T dt} \\
 &= \frac{2I_0}{T} \left[\frac{-\cos(\omega t + \phi)}{\omega} \right]_{T/2}^T \\
 \Rightarrow I_{av}(\text{over - ve half cycle}) &= -\frac{2I_0 \cos \phi}{\pi} \quad \dots 10.2.3
 \end{aligned}$$

Thus we see that the average value of a.c. over the - ve half cycle is the negative of its average over the + ve half cycle and hence the average of a.c. over the full cycle becomes zero. $I_{av(\text{half})}$ is found to be that steady current which sends the same charge through the circuit as is done by a.c. in a half cycle in a given direction.

From eq. 10.2.2 we have $I_{av(\text{half})} = \frac{2I_0}{\pi}$,

if $\phi = 0$, and it is thus 0.637 times the peak value of a.c. As the average value of a.c. over a full cycle is zero, a moving coil galvanometer gives zero deflection when connected in an a.c. circuit. Such I_{av} is hardly, of any use. Because of this, effective or r.m.s. value of a.c. is of practical use and most a.c. meters are calibrated to read this $I_{eff.}$ or I_{rms} value. Let us calculate it.

Effective or r.m.s. value of a.c. (I_{eff} or I_{rms})

The effective or r.m.s. (root mean square) value of a.c. over a particular time interval is defined as that value of steady d.c. which produces the same heat in a given resistor as is done by the a.c. in the said resistor in the same time interval.

Let us take the a.c. as $I = I_0 \sin(\omega t + \phi)$. The heat produced dQ by this a.c. in a resistor R over a time dt is $dQ = I^2 R dt$. Then total heat produced in one complete cycle is :

$$\begin{aligned}
 Q &= \int_0^T I^2 R dt = R \int_0^T I_0^2 \sin^2(\omega t + \phi) dt \\
 &= \frac{I_0^2 R}{2} \left[\int_0^T dt - \int_0^T \cos 2(\omega t + \phi) dt \right] \\
 &\left[\because \sin^2(\omega t + \phi) = \frac{1 - \cos 2(\omega t + \phi)}{2} \right] \\
 &= \frac{I_0^2 R}{2} \left[T - \left\{ \frac{\sin 2(\omega t + \phi)}{2\omega} \right\} \right]_0^T \\
 &= \frac{I_0^2 R}{2} \left[T - \frac{1}{2\omega} \{ \sin 2(\omega T + \phi) - \sin 2\phi \} \right] \\
 &= \frac{I_0^2 R}{2} \left[T - \frac{1}{2\omega} \{ \sin(4\pi + 2\phi) - \sin 2\phi \} \right] \\
 &= \frac{I_0^2 R}{2} \left[T - \frac{1}{2\omega} (\sin 2\phi - \sin 2\phi) \right] \\
 Q &= \frac{I_0^2 RT}{2} \quad \dots 10.2.4
 \end{aligned}$$

If a steady I_{eff} produces the same heat Q in joules in a resistor R in time T , then, clearly

$$Q = I_{\text{eff}}^2 RT \quad \dots 10.2.5$$

so that

$$\begin{aligned} \frac{I_0^2 RT}{2} &= I_{\text{eff}}^2 RT \\ \Rightarrow I_{\text{eff}}^2 &= \frac{I_0^2}{2} \\ \Rightarrow I_{\text{eff}} &= \frac{I_0}{\sqrt{2}} \quad \dots 10.2.6 \end{aligned}$$

It is to be noted here that whether the instantaneous a.c. is +ve or -ve at a given instant, its square is always positive. Hence its average value over a cycle must be positive. Such mean square value of a.c. over a cycle is given by

$$\begin{aligned} I_{\text{mean}}^2 &= \frac{\int_0^T I^2 dt}{\int_0^T dt} = \frac{\int_0^T I_0^2 \sin^2(\omega t + \phi) dt}{T} \\ \Rightarrow I_{\text{mean}}^2 &= \frac{I_0^2}{T} \int_0^T \sin^2(\omega t + \phi) dt \\ &= \frac{I_0^2}{2T} \left[t - \frac{\sin 2(\omega t + \phi)}{2\omega} \right]_0^T \\ &= \frac{I_0^2 T}{2T} - 0 \\ \Rightarrow I_{\text{mean}}^2 &= \frac{I_0^2}{2} \quad \dots 10.2.7 \end{aligned}$$

I_{mean}^2 is called the mean square value of a.c. Its square root is called root mean square value of a.c. or I_{rms} . Hence

$$I_{\text{rms}} = \sqrt{I_{\text{mean}}^2} = \frac{I_0}{\sqrt{2}} \quad \dots 10.2.8$$

$$\text{Thus we see that } I_{\text{eff}} = I_{\text{rms}} = \frac{I_0}{\sqrt{2}} = 0.707 I_0$$

I_{eff} or I_{rms} is also called the virtual value of a.c. or I_{ver} . Such virtual a.c. is thus 0.707 times the peak value of a.c.

In the same manner we may obtain the effective value or rms value or virtual value of alternating emf ϵ_{eff} which is given by

$$\epsilon_{\text{eff}} = \frac{\epsilon_0}{\sqrt{2}} \quad \dots 10.2.9$$

where, ϵ_0 is the peak value of alternating emf.

Any meter, measuring alternating voltage or current measures this effective or r.m.s. value of voltage or current. When we say that the household supply of a.c. is at 220 volt, it means that r.m.s. or effective value of alternating voltage is 220 volt. Its peak value is $\sqrt{2} \times 220\text{V} = 311.08\text{V}$. In sinusoidal variations of a.c., the ratio of the peak value of a.c. to its rms value is called the **peak factor**. It is denoted as K_p and is given by

$$K_p = \frac{I_0}{I} = \sqrt{2} \quad \dots 10.2.10$$

Similarly, the ratio of the rms value of a.c. to its average value over a half cycle is known as the **form factor** K_f . It is given by (for $\phi = 0$)

$$K_f = \frac{I_{\text{rms}}}{I_{\text{av(half)}}} = \frac{I_0/\sqrt{2}}{2I_0/\pi} = \frac{\pi}{2\sqrt{2}} \quad \dots 10.2.11$$

Example 10.2.1

Write down the equation to show the relation between the instantaneous and peak emf of a generator marked 230 V - 60 Hz.

Soln.

$$\begin{aligned} \text{Given that } \epsilon_{\text{eff}} &= 230 \text{ V} \\ f &= 60 \text{ cps.} \end{aligned}$$

$$\therefore \omega = 2\pi f = 120\pi \text{ per sec.}$$

$$\begin{aligned} \epsilon_0 &= \epsilon_{\text{eff}} \sqrt{2} = 230\sqrt{2} \text{ V} \\ &= 325.3 \text{ V} \end{aligned}$$

Assuming the initial phase angle to be zero, the instantaneous value of a.c. emf is given by

$$\epsilon = \epsilon_0 \sin(\omega t)$$

$$\Rightarrow \epsilon = 325.3 \sin 120\pi t$$

Example 10.2.2

An electric kettle marked 220V - 500 W is connected to house mains of a.c. supply of 220 V - 50 Hz. Find the peak value of emf, the rms value of emf and the virtual current. Write down the equation for instantaneous a.c.

Soln.

Given that $\epsilon_{\text{eff}} = 220 \text{ V}$

$P = 500 \text{ watt}$

$f = 50 \text{ Hz}$

\therefore The peak value of emf

$$\begin{aligned} \epsilon_0 &= \epsilon_{\text{eff}} \sqrt{2} = 220\sqrt{2} \text{ volt} \\ &= 311.13 \text{ volt} \end{aligned}$$

The rms value of emf $= \epsilon_{\text{rms}} = \epsilon_{\text{eff}} = 220 \text{ volt}$

$$\begin{aligned} \text{The virtual current } I_{\text{vir}} = I_{\text{rms}} &= \frac{P}{\epsilon_{\text{eff}}} = \frac{500 \text{ watt}}{220 \text{ volt}} \\ &= 2.27 \text{ ampere} \end{aligned}$$

$\therefore f = 50 \text{ Hz}, \omega = 2\pi f = 100\pi \text{ per sec.}$

\therefore The equation to instantaneous a.c. is

$$\begin{aligned} I &= I_0 \sin \omega t \\ &= I_{\text{eff}} \sqrt{2} \sin \omega t \\ &= 2.27\sqrt{2} \sin 100\pi t \end{aligned}$$

$$\Rightarrow I = 3.21 \sin 100\pi t$$

10.3 : Simple a.c. circuits

A simple a.c. circuit contains an a.c. source \odot and may contain a resistor, an inductor or a

capacitor or a combination of any two or all the three types of these elements. While a resistor has the same role in both a.c. and d.c. circuits, an inductor and a capacitor have different effects in the two. An inductor does not have any role in a steady d.c. circuit. It simply adds to the resistance. However, its role in an a.c. circuit is to produce a back emf as we have seen earlier. Its opposing effect is expressed by a parameter called **inductive reactance** (X_L) and is measured in ohm. Similarly a capacitor provides infinite resistance to the flow of charges in a d.c. circuit and no current is obtained in that part of a circuit in which a capacitor is connected. But it allows a.c. to pass through it and thus it has much less opposing effect in an a.c. circuit. Its opposing effect in an a.c. circuit is expressed by a parameter called capacitive reactance (X_C) which is also measured in ohm. With this background let us see the behaviour of a.c. in different circuits.

The analysis of such circuits is facilitated by use of **vector diagrams** similar to those used in the study of harmonic motion. In such diagrams, the instantaneous value of a quantity (emf or current) that varies sinusoidally with time is represented by the projection of a vector onto a horizontal or vertical axis. The length of the vector corresponds to the amplitude of the quantity and it rotates counter clockwise with angular velocity ω . In the context of a.c. circuit analysis, these rotating vectors are often called **phasors** and diagrams containing them are called **phasor diagrams**. Let us now take up some of the simple a.c. circuits one by one.

(i) **A.C. circuit containing only a resistor :**

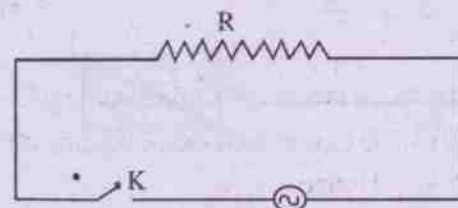

Fig. 10.3
(a.c. circuit containing a resistor R)

An a.c. circuit containing a resistor is shown in Fig. 10.3. Let the instantaneous emf of the source be given by

$$\varepsilon = \varepsilon_0 \sin \omega t \quad \dots 10.3.1$$

This instantaneous emf is used to overcome the resistance of the resistor to maintain the charge flow. If I is the instantaneous current in the circuit, we use Kirchhoff's loop law to obtain

$$\begin{aligned} \varepsilon_0 \sin \omega t &= RI \\ \Rightarrow I &= \frac{\varepsilon_0}{R} \sin \omega t \quad \dots 10.3.2 \end{aligned}$$

where, $I_0 = \varepsilon_0 / R =$ peak value of current. It is the ratio of peak value of emf to the resistance of the circuit.

Equations 10.3.1 and 10.3.2 show that the instantaneous current in a purely resistive circuit has the same phase as the emf at that instant. It is sinusoidal in nature. Graphically the variations of emf and current with time (i.e. ωt) are shown in fig. 10.4. It shows that emf and current vary in the same manner with time except that they have different amplitudes. The phasor diagram for emf and current in the resistive a.c. circuit is given in fig. 10.5.

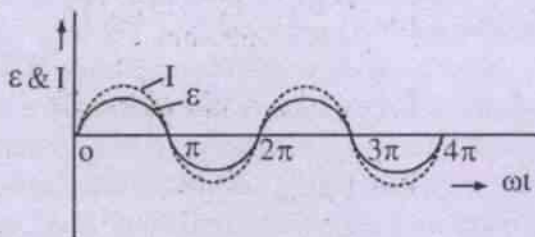

Fig. 10.4

(Variations of ε and I with time for a purely resistive a.c. circuit)

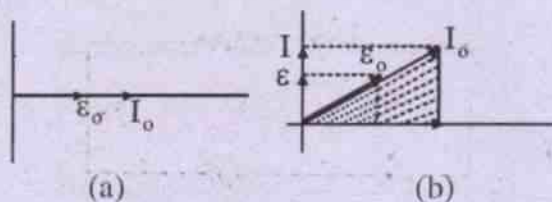

Fig. 10.5

(Phasor diagram for purely resistive a.c. circuit)

It is to be noted that in Figs. 10.4 and 10.5 the greater amplitude of current in the diagram is of no significance, because the choice of vertical scale for I and ε is arbitrary. Because the current and emf are in phase and have the same frequency, the current and emf phasors rotate together.

Instantaneous power in the circuit

The instantaneous power P in any current circuit is given by the product of instantaneous current and emf, i.e.

$$\begin{aligned} P &= \varepsilon I \\ &= \varepsilon_0 \sin \omega t \cdot I_0 \sin \omega t \\ &= \varepsilon_0 \sin \omega t \cdot \frac{\varepsilon_0}{R} \sin \omega t \\ &= \frac{\varepsilon_0^2}{R} \sin^2 \omega t \\ \Rightarrow P &= P_0 \sin^2 \omega t \quad \dots 10.3.3 \end{aligned}$$

where $P_0 = \frac{\varepsilon_0^2}{R} = I_0^2 R =$ peak value of power

From eq. 10.3.3

$$P = P_0 \sin^2 \omega t$$

Using trigonometric identity

$$\cos 2\omega t = (1 - 2\sin^2 \omega t),$$

$$P = P_0 \left(\frac{1 - \cos 2\omega t}{2} \right)$$

$$\Rightarrow P = \frac{P_0}{2} - \frac{P_0 \cos 2\omega t}{2} \quad \dots 10.3.4$$

This shows that P varies periodically with time, the angular frequency of variation being 2ω . It is always pulsating and it pulsates at twice the frequency of voltage and current. The variation of P with t is shown in Fig. 10.6.

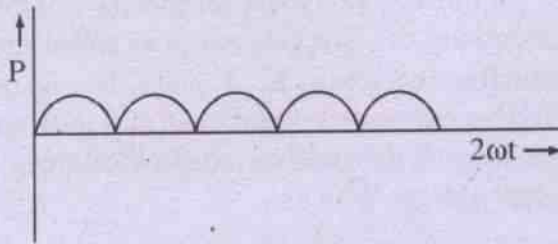

Fig. 10.6

(Variation P with t for a purely resistive a.c. circuit)

Since the power is positive for both forward and reverse directions of current, electrical energy is continuously converted to heat energy in the resistor whatever may be the direction of charge flow.

If an electric bulb is operated by an a.c. source having a frequency of 50 Hz, it glows continuously because of the conversion of electrical energy into light energy. Though the current over a period passes through a series of maxima and minima, yet the bulb does not seem to flicker. It is due to persistence of vision.

Average power in the circuit

The average power \bar{P} in an a.c. circuit is the average rate of conversion of electrical energy into heat energy. It is equal to the power averaged over a period i.e.

$$\begin{aligned} \bar{P} &= \frac{\int_0^T P dt}{\int_0^T dt} = \frac{1}{T} \int_0^T P_o \sin^2 \omega t dt \\ &= \frac{P_o}{2T} \int_0^T (1 - \cos 2\omega t) dt \\ &= \frac{P_o}{2T} \left[\int_0^T dt - \int_0^T \cos 2\omega t dt \right] \\ \Rightarrow \bar{P} &= \frac{P_o}{2T} [T - 0] = \frac{P_o}{2} \quad \dots 10.3.5 \end{aligned}$$

This average power can also be written as

$$\bar{P} = \frac{P_o}{2} = \frac{I_o}{\sqrt{2}} \cdot \frac{\epsilon_o}{\sqrt{2}} = I_{eff} \cdot \epsilon_{eff} \quad \dots 10.3.6$$

It is also called the active power input of the circuit.

Example 10.3.1.

An alternating emf $\epsilon = 100 \sin 100\pi t$ is fed to a resistive circuit having total resistance 50 ohm. Find the rms values of emf and current and the average power input.

Soln.

Given $\epsilon = \epsilon_o \sin \omega t = 100 \sin 100\pi t$

This gives $\epsilon_o = 100$ volts (say)

$$2\pi f = \omega = 100\pi$$

$$\therefore f = \frac{100\pi}{2\pi} = 50 \text{ Hz}$$

$$\therefore \epsilon_o = 100 \text{ volts}$$

$$\epsilon_{eff} = \frac{\epsilon_o}{\sqrt{2}} = \frac{100}{\sqrt{2}} = 50\sqrt{2} \text{ volt}$$

$$\therefore I_{eff} = \frac{\epsilon_{eff}}{R} = \frac{50\sqrt{2}}{50 \text{ ohm}} = \sqrt{2} \text{ A}$$

$$\therefore I_o = \sqrt{2} I_{eff} = \sqrt{2} \cdot \sqrt{2} \text{ A} = 2 \text{ A}$$

$$\begin{aligned} \therefore \bar{P} &= I_{eff} \epsilon_{eff} = \frac{I_o \epsilon_o}{2} \\ &= \frac{2 \text{ A} \cdot 100 \text{ V}}{2} = 100 \text{ watt} \end{aligned}$$

(ii) A.C. circuit containing only an inductor :

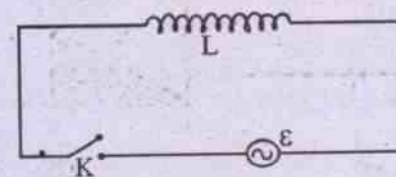

Fig. 10.7

(A.C. circuit containing only an inductor)

An a.c. source of instantaneous emf ϵ is shown to be connected to an ideal inductor of inductance L through a switch K in fig. 10.7. The inductor is said to be ideal in the sense that its resistance is negligible or practically zero.

The instantaneous back emf (induced emf) produced in the inductor is $-L \frac{dI}{dt}$ where I is the instantaneous a.c. at time t . The instantaneous emf $\epsilon = \epsilon_0 \sin \omega t$ provided by the source is used to overcome this back emf and maintain the charge flow. From Kirchhoff's loop law

$$\begin{aligned} \epsilon_0 \sin \omega t - L \frac{dI}{dt} &= 0 \\ \Rightarrow \frac{dI}{dt} &= \frac{\epsilon_0}{L} \sin \omega t \\ \Rightarrow dI &= \frac{\epsilon_0}{L} \sin \omega t dt \end{aligned}$$

Integrating both sides we get

$$I = -\frac{\epsilon_0}{\omega L} \cos \omega t + C \quad \dots 10.3.7$$

where C is the integration constant.

The constant of integration has the dimensions of current. It is steady and hence independent of time. The rest two terms in eq. 10.3.7 are time dependent terms. As there is no source to produce steady current in the circuit, C must be zero. Hence eq. 10.3.7 becomes

$$I = -\frac{\epsilon_0}{\omega L} \cos \omega t$$

Using the identity $-\cos \omega t = \sin(\omega t - \pi/2)$,

$$\Rightarrow I = \frac{\epsilon_0}{\omega L} \sin(\omega t - \pi/2) \quad \dots 10.3.8$$

$$\Rightarrow I = I_0 \sin(\omega t - \pi/2) \quad \dots 10.3.9$$

where $I_0 = \frac{\epsilon_0}{\omega L}$ is the peak value of a.c. ...10.3.10

From eq. 10.3.10 we see that ωL has the dimensions of resistance and it is called the **inductive reactance, X_L** . It plays the role of effective resistance in the circuit. However, an ideal inductor does not convert electrical energy to heat energy. Why?

Eq. 10.3.9 shows that the current through the inductor varies sinusoidally with time and is not in phase with the instantaneous emf. Comparing eq. 10.3.9 with the equation for emf we see that the phase of current is $\pi/2$ less than that of emf. In other words, **the current lags behind the emf by phase $\pi/2$** . The variations of emf and current with time in a

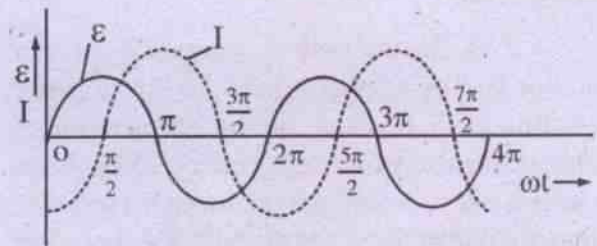

Fig. 10.8

(Variation of ϵ and I with time in a purely inductive circuit)

purely inductive circuit is shown in fig. 10.8. The corresponding phasor diagram is given in fig. 10.9.

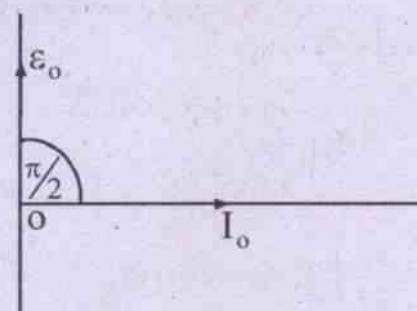

Fig. 10.9

(Phasor diagram for current and emf in a purely inductive circuit)

It is seen that the emf in a purely inductive circuit leads the current by a phase $\pi/2$.

The inductive reactance

As stated earlier, the opposition to flow of charges in a purely inductive circuit is measured by a term called inductive reactance

$$X_L = \omega L \quad \dots 10.3.11$$

The unit of R_L in S.I. system =

$$\frac{\text{henry}}{\text{sec ond}} = \frac{\text{ohm sec ond}}{\text{sec ond}} = \text{ohm}$$

From eq. 10.3.11, $X_L = \omega L = \frac{\epsilon_o}{I_o}$, so that when

$\epsilon_o = 1 \text{ V}$ and $I_o = 1 \text{ A}$, $R_L = 1 \text{ ohm}$. In other words an a.c. circuit containing a pure inductor has an inductive reactance of 1 ohm when an a.c. of peak value 1A maintained through the inductor creates an inductive voltage drop of 1V.

$$\therefore X_L = \omega L = 2\pi fL,$$

inductive reactance is directly proportional to

- (i) the self inductance L of the inductor
- and (ii) the frequency of a.c.

One can easily see that for a d.c. circuit $f = 0$, so that $X_L = 0$. It means that an inductor has no effect in a d.c. circuit.

Power in a purely inductive circuit

The instantaneous power in an inductive a.c. circuit is given by

$$P = \epsilon I = \epsilon_o \sin \omega t (-I_o \cos \omega t)$$

$$\Rightarrow P = -\frac{\epsilon_o I_o}{2} \sin 2\omega t \quad \dots 10.3.12$$

$$\Rightarrow P = -P_o \sin 2\omega t \quad \dots 10.3.13$$

$$\text{where the peak power } P_o = \frac{\epsilon_o I_o}{2} \quad \dots 10.3.14$$

Thus we see from eq. 10.3.13 that the instantaneous power is sinusoidal at twice the frequency of the applied emf. Graphically the variation of P with ωt is shown in Fig. 10.10. The graph is sinusoidal in shape

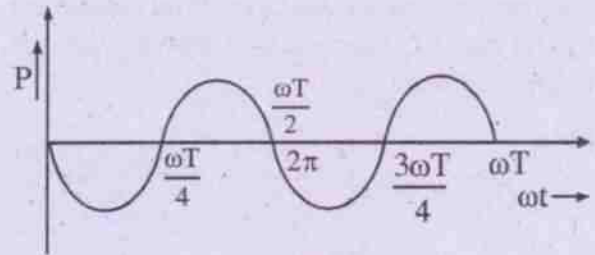

Fig. 10.10

(Variation P is purely inductive with ωt) at twice the frequency of emf and current.

The instantaneous power becomes alternately -ve and +ve after equal time intervals i.e. $T/4$. Energy is received by the inductor device from the source during one quarter period and is returned to the source during the next quarter. The power is $-\frac{P_o}{2}$ at $T/8$ and $+\frac{P_o}{2}$ at $3T/8$ and the sequence continues.

The average power or true power is zero in a pure inductor since the average of $\sin 2\omega t$ over a complete cycle is zero.

Hence we may calculate the **reactive power** P_R for a pure inductor. It is the product of effective values of current and emf over a cycle, i.e.

$$P_R = \epsilon_{\text{eff}} I_{\text{eff}} \quad \dots 10.3.15$$

The current through the inductor produces magnetic energy which is stored in the magnetic field around the inductor. As the current alternates with time it becomes zero for a moment during change. Then the field (magnetic) collapses and returns all its energy to the circuit. Hence the power in an inductor is not dissipated. It alternately goes to the circuit and the magnetic field created by the current. Hence the reactive power P_R of a pure inductor is also called **wattless power** or **apparent power**. It is measured in watt.

Example 10.3.2

An ideal inductor of self inductance 1 H is connected to an a.c. source of 50V having

angular frequency 1000 rad/s. Find the current in the circuit, the reactive power and the inductive reactance.

Soln.

$$\text{Give } L = 1\text{H}$$

$$\epsilon_{\text{eff}} = 50\text{ V}$$

$$\omega = 1000 \frac{\text{rad}}{\text{s}}$$

We have to find I_{eff} and P_R .

$$\therefore \epsilon_{\text{eff}} = 50\text{V}, \epsilon_0 = \epsilon_{\text{eff}} \sqrt{2} = 50\sqrt{2}\text{ V}$$

Let us write the equation for instantaneous emf as $\epsilon = \epsilon_0 \sin \omega t = 50\sqrt{2} \sin 1000t$

As the circuit is purely inductive

$$\begin{aligned} I &= \frac{\epsilon_0}{L\omega} \sin(\omega t - \pi/2) \\ &= \frac{50\sqrt{2}}{1\text{H} \cdot 1000/\text{s}} \sin(\omega t - \pi/2) \\ &= I_0 \sin(\omega t - \pi/2) \end{aligned}$$

$$\therefore I_0 = \frac{50\sqrt{2}}{1000}\text{ A}$$

$$\therefore I_{\text{eff}} = \frac{I_0}{\sqrt{2}} = \frac{50\sqrt{2}\text{A}}{1000\sqrt{2}} = 0.05\text{A}$$

$$\begin{aligned} \therefore P_R &= \text{Reactive power} = \epsilon_{\text{eff}} \cdot I_{\text{eff}} \\ &= 50 \times 0.05 \text{ watt} = 2.5 \text{ watt} \end{aligned}$$

$$\begin{aligned} \text{Inductive reactance} &= L\omega = 1\text{H} \times 1000 \frac{\text{rad}}{\text{s}} \\ &= 1000 \text{ ohm} \end{aligned}$$

Note : For a.c. circuits P_R is also expressed as VA i.e. volt ampere.

(iii) A.C. circuit containing a pure capacitor :

Let us take an a.c. source ϵ connected across a capacitor C through key K (fig. 10.11).

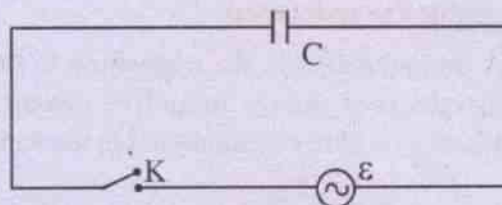

Fig. 10.11

(A.C. source connected to only a capacitor)

It is assumed that there is no resistance nor inductance in the circuit. Thus it is a purely capacitive circuit. On making the switch on charges of both kinds deposit on the capacitor plates and current is observed. It is continuous but alternating in nature. We may recall that when a capacitor is connected to a d.c. source such as a chemical cell, there is a current for an extremely short interval in which the capacitor is charged. Thereafter no current is observed. But when an a.c. source is connected to the capacitor plates, there is current in the circuit so long as the switch is made on. This is because the charges on the plates go on changing continuously not only in magnitude but also in sign. They oscillate between the two plates. Thus current is observed till the source is disconnected.

Let the instantaneous emf of the source be given by

$$\epsilon = \epsilon_0 \sin \omega t \quad \dots 10.3.17$$

If q is the amount of charge on the capacitor plates at this time, we have

$$q = C\epsilon = C\epsilon_0 \sin \omega t \quad \dots 10.3.18$$

where C is the capacitance of the capacitor.

Then the instantaneous current I in the circuit is given by

$$I = \frac{dq}{dt} = \frac{d}{dt}(C\epsilon_0 \sin \omega t)$$

$$\Rightarrow I = C \epsilon_0 \omega \cos \omega t = \frac{\epsilon_0}{1/C\omega} \cos \omega t$$

$$\Rightarrow I = I_o \cos \omega t = I_o \sin(\omega t + \pi/2) \quad \dots 10.3.19$$

where $I_o = C\omega \epsilon_o = \frac{\epsilon_o}{1/C\omega} \quad \dots 10.3.20$
 = the peak value of the current

It is seen that (i) the current in the capacitive a.c. circuit varies sinusoidally with time and (ii) is not in phase with the instantaneous emf.

A comparison of equations 10.3.17 and 10.3.19 shows that (iii) **the current leads the emf by a phase $\pi/2$** . It means that the current becomes zero when the emf is maximum and vice versa. Graphically the variations of emf and current are shown in Fig. 10.12. The corresponding phasor diagram is given in Fig. 10.13.

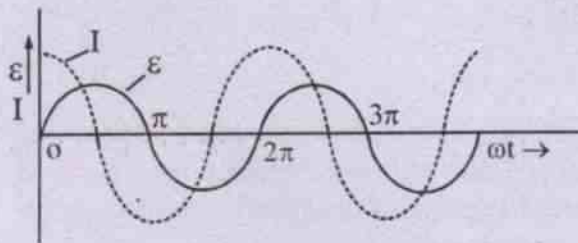

Fig. 10.12

(Variation of emf and current with time in a purely capacitive circuit)

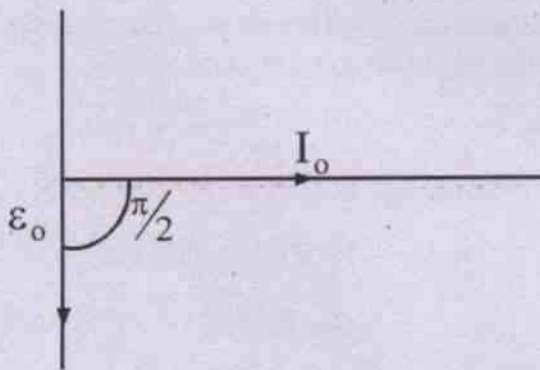

Fig. 10.13

(Phasor diagram showing emf and current)

It shows that in a capacitive a.c. circuit, the emf lags behind the current by $\pi/2$.

The capacitive reactance

From eq. 10.3.20, we see that

$$I_o = C\omega \epsilon_o = \frac{\epsilon_o}{1/C\omega}$$

$$\Rightarrow I_o = \frac{\epsilon_o}{X_c}$$

where X_c is called the **capacitive reactance** of the capacitor and is given by

$$X_c = \frac{1}{C\omega} = \frac{1}{2\pi Cf} \quad \dots 10.3.21$$

X_c plays the role of resistance in a capacitive a.c. circuit and has the dimensions of resistance too. Its unit in S.I. system is ohm (Ω). It can be verified from eq. 10.3.21.

$$\begin{aligned} \frac{\text{farad}}{\text{sec ond}} &= \frac{1}{\frac{\text{coulomb}}{\text{volt. sec ond}}} \\ &= \frac{\text{volt. sec ond}}{\text{ampere. sec ond}} = \frac{\text{volt}}{\text{ampere}} = \text{ohm} \end{aligned}$$

From eq. 10.3.21, we see that

$$X_c \propto \frac{1}{f} \text{ and } X_c \propto \frac{1}{C}$$

Hence the capacitive reactance of the capacitor is inversely proportional to (i) the frequency f of the a.c. source and (ii) the capacitance C of the capacitor. It is independent of the magnitude of alternating emf.

It is now easy to find why the current in a capacitive a.c. circuit becomes zero, where $f = 0$ and $X_c = \infty$. Thus the response of a capacitor to an a.c. source depends on the frequency of the source.

Instantaneous power

The instantaneous power in a capacitive a.c. circuit is given by

$$\begin{aligned} P &= \epsilon I = \epsilon_o \sin \omega t \cdot I_o \sin(\omega t + \pi/2) \\ &= \epsilon_o \sin \omega t \cdot I_o \cos \omega t \end{aligned}$$

$$= \frac{\epsilon_0 I_0}{2} \sin 2\omega t$$

$$\Rightarrow P = \frac{1}{2} P_0 \sin 2\omega t \quad \dots 10.3.22$$

Thus the instantaneous power in a capacitive a.c. circuit is sinusoidal with a frequency $2f$, i.e. twice the frequency of a.c. source. Graphically the variation of P with t is shown in Fig. 10.14. The graph is sinusoidal in shape at twice the frequency of emf and current.

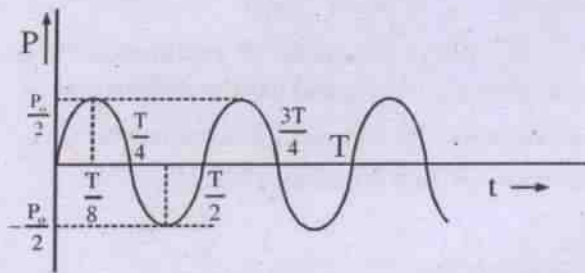

Fig. 10.14

(Variation of P with ωt for a purely capacitive a.c. circuit)

The instantaneous power becomes alternately +ve and -ve for equal time intervals.

For $\epsilon = \epsilon_0 \sin \omega t$, P is $P_{\max} = \frac{P_0}{2}$ at $\frac{T}{8}$ and $-\frac{P_0}{2}$ at $\frac{3T}{8}$. It is zero at $t = 0, T/4, T/2, 3T/4$ and T and the sequence continues.

The voltage across the capacitor rises from 0 to maximum value during the first quarter cycle. The electrical energy provided by the source is stored in the electric field of the capacitor, which gets charged. During this period there is charge flow in the direction of applied voltage. In the next quarter cycle ϵ drops from ϵ_0 to zero and there is charge flow opposite to that of the applied voltage. The capacitor gets discharged and delivers energy to the source. This sequence continues. Thus the circuit becomes a source of power during 2nd, 4th, 6th, etc. i.e. in even quarter cycles.

Average power

The average power or true power is zero during one time period as the average of $\sin 2\omega t$ over a cycle of a.c. is zero. Hence the reactive power P_R for a pure capacitor is calculated.

Reactive power

The reactive power for a purely capacitive a.c. circuit is the product of the effective values of current and emf, i.e.

$$P_R = \epsilon_{\text{eff}} \cdot I_{\text{eff}} \quad \dots 10.3.23$$

$$\Rightarrow P_R = \epsilon_{\text{eff}} \cdot \frac{\epsilon_{\text{eff}}}{R_C} = \frac{\epsilon_{\text{eff}}^2}{R_C} = \frac{\epsilon_0^2}{2R_C} \quad \dots 10.3.24$$

Also

$$P_R = I_{\text{eff}} R_C \cdot I_{\text{eff}} = I_{\text{eff}}^2 R_C = \frac{I_0^2}{2} R_C \quad \dots 10.3.25$$

P_R is also called the **apparent power** of the circuit whereas P , the average power, is called the **active power**. For a purely capacitive circuit active power is zero.

Example 10.3.3

A capacitor of capacitance $50 \mu\text{F}$ is connected to a 60 Hz a.c. source which provides 24V (rms). Find the capacitive reactance, the maximum charge on the plates of the capacitor and the maximum current in the circuit.

Soln.

Given $C = 50 \mu\text{F} = 50 \times 10^{-6} \text{ F}$

$$f = 60 \text{ Hz} = 60 / \text{sec}$$

$$\epsilon_{\text{rms}} = 24 \text{ V}$$

\therefore The capacitive reactance

$$X_C = \frac{1}{C\omega} = \frac{1}{C2\pi f}$$

$$\Rightarrow X_C = \frac{1}{50 \times 10^{-6} \text{ F} \times 2\pi \times 60 / \text{sec}}$$

$$= \frac{10^6 \text{ sec. volt}}{6000\pi \text{ coulomb}} = \frac{1000}{6\pi} \text{ ohm}$$

$$= 53.05 \text{ ohm} = 53 \text{ ohm}$$

$$\therefore \epsilon_{\text{rms}} = 24\text{V}, \epsilon_o = \epsilon_{\text{rms}} \sqrt{2} = 24\sqrt{2} \text{ volt}$$

$$\therefore q_o = C\epsilon_o = 50 \times 10^{-6} \text{ F} \times 24\sqrt{2} \text{ V}$$

$$= 1697.05 \times 10^{-6} \text{ coulomb}$$

$$\approx 1.7 \times 10^{-3} \text{ coulomb}$$

Similarly

$$I_o = \frac{\epsilon_o}{R_C} = \frac{24\sqrt{2} \text{ volt}}{53 \text{ ohm}} = 0.64 \text{ ampere}$$

Impedance of a.c circuits

In all types of a.c. circuits, the relation between peak emf and peak current is expressed as

$$\epsilon_o = I_o Z \quad \dots 10.3.26$$

where Z , in general, is called the impedance of the circuit. It is measured in ohm and plays the role of resistance in a steady d.c. circuit. $Z = R$ for a purely resistive a.c. circuit, $Z = \omega L$ for a purely inductive a.c. circuit and $Z = \frac{1}{\omega C}$ for a purely capacitive a.c. circuit.

The Phase Factor

It is to be noted that generally the current and emf are not in phase in an a.c. circuit. When the instantaneous emf is given by

$$\epsilon = \epsilon_o \sin \omega t,$$

the instantaneous current is generally expressed as

$$I = I_o \sin(\omega t + \phi)$$

where ϕ is the phase difference between the emf and current or the phase factor. ϕ may be +ve or -ve.

For a purely resistive circuit $\phi = 0$

For a purely inductive circuit $\phi = -\pi/2$

For a purely capacitive circuit $\phi = +\pi/2$

10.4 More about a.c. circuit

So far we have confined our discussion to a.c. circuits containing (i) a pure resistor, (ii) a pure inductor and (iii) a pure capacitor. Such circuits are ideal circuits, however, as we cannot get practically an inductor or a capacitor without any resistance. Hence in the practical case we may have a combination of these elements. We shall confine our discussion to series combinations only at this stage. Suppose the instantaneous emf of a.c. source connected in the circuit is given by

$$\epsilon = \epsilon_o \sin \omega t$$

Then the instantaneous current in the circuit can be obtained by a simple method when the circuit contains any one of the above elements or a combination of them.

In this method the resistance R of the circuit is represented by a vector having its magnitude proportional to R and is drawn along the +ve X-axis. Then the reactance R_C of a capacitor is drawn as a vector of magnitude

proportional to $X_C = \frac{1}{\omega C}$ along the +ve Y-axis

and the reactance X_L of an inductor is drawn as a vector of magnitude proportional to the inductive reactance $X_L = \omega L$ along the -ve Y axis. Such a convention is followed taking into account the fact that the current in a capacitor leads the emf by a phase $\pi/2$ and that in an inductor lags behind the emf by a phase $\pi/2$ whereas it is in phase with emf in a resistor.

The impedance Z and the phase factor ϕ are found by adding these three vectors. The magnitude of the sum gives the impedance Z and the angle made by the resultant gives the phase factor ϕ . Fig. 10.15 illustrates it.

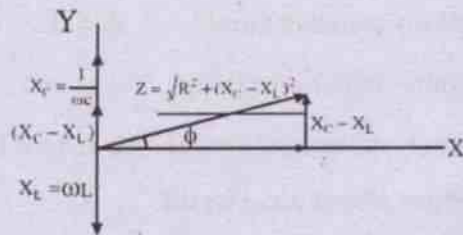

Fig. 10.15

(Finding impedance Z and phase factor ϕ vectorially)

However, it is to be noted that though the three circuit parameters R , R_C and R_L are added as vectors, they are not vectors actually. It is for convenience that this convention for adding the three is followed. With this background let us analyse some a.c. circuits having a series combination of any two of these parameters or of all the three.

(iii) *A.C. through series L - C - R circuit :*

In many cases, a.c. circuits include resistance R , inductive reactance R_L and capacitive reactance R_C in series (Fig. 10.20).

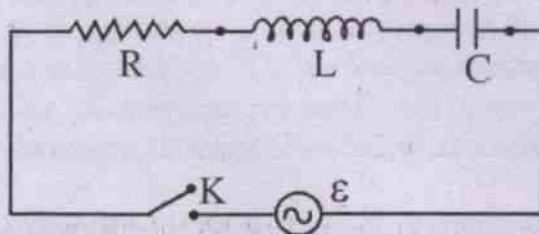

Fig. 10.20

(R - L - C series circuit with an a.c. source)

Such circuits are very well analysed by use of a phasor diagram. It includes the voltage and current vectors for various components. Here the instantaneous total voltage across all the three components equals the source voltage or emf of the source (for $r=0$) at that instant. Its phasor is the vector sum of the phasors for individual voltages (Fig. 10.21). Accordingly the vector representing R has been taken along +ve X-axis, that representing X_C and X_L have been taken along +ve Y-axis and -ve Y-axis. The

resultant of $\frac{1}{\omega C}$ and ωL is

$$X = X_C - X_L = \left(\frac{1}{\omega C} - \omega L \right) \quad \dots 10.4.9$$

which is shown along +ve Y-axis, assuming $\frac{1}{\omega C}$ to be greater than ωL . X represents the total reactance of the circuit. The impedance Z

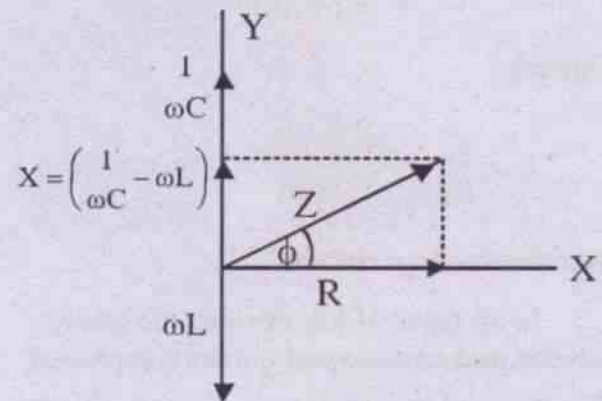

Fig. 10.21

(Vector diagram to find Z and ϕ for R - L - C a.c. circuit)

of the circuit is shown to be the resultant of X and R in Fig. 10.21, clearly

$$Z = \sqrt{R^2 + \left(\frac{1}{\omega C} - \omega L \right)^2} \quad \dots 10.4.10$$

Z makes an angle ϕ with X-axis and we have

$$\tan \phi = \frac{X}{R} = \frac{\frac{1}{\omega C} - \omega L}{R} \quad \dots 10.4.11$$

Thus the instantaneous current in the circuit is given by

$$I = \frac{\epsilon_0}{\sqrt{R^2 + \left(\frac{1}{\omega C} - \omega L \right)^2}} \sin(\omega t + \phi)$$

...10.4.12

where ϕ is phase by which current leads the emf and it is given by eq. 10.4.11. Eq. 10.4.12 may be written as

$$I = I_0 \sin(\omega t + \phi) \quad \dots 10.4.13$$

where $I_0 = \frac{\epsilon_0}{\sqrt{R^2 + \left(\frac{1}{\omega C} - \omega L\right)^2}} \quad \dots 10.4.14$

If $X_L > X_C$, the vector for the net reactance i.e. $X_L - X_C$ is along -ve Y-axis. Here the phase angle is -ve and the current lags behind the emf by phase ϕ .

If $X_L = X_C$, the net reactance is zero. The circuit then behaves as a purely resistive circuit and Z is along X-axis, i.e. along the resistance axis. The current is in phase with the emf in this case.

Eq. 10.4.10 is the general expression for impedance of the circuit when all the three components R, L and C are connected in it.

- (i) When $R = 0$, the circuit becomes a L - C circuit. The impedance in this case is the net reactance of the circuit. The current-voltage relationship is given by eq. 10.4.12 with $R = 0$ in it. The circuit is ideal, however, because there is hardly any pure inductor without any resistance.
- (ii) When $C = 0$, the circuit becomes an L - R circuit. The impedance, phase angle and current in the circuit are obtained from equations 10.4.10, 10.4.11 and 10.4.12 respectively by putting $C = 0$ in them. Verify the validity comparing these equations with equations 10.4.1, 10.4.2 and 10.4.4.
- (iii) When $L = 0$, the circuit becomes the R - C circuit. One may get all required quantities for the circuit by putting $L = 0$ in the equations developed for R - L - C circuit.

Analytical Solution :

We consider the circuit as shown in fig. 10.20 connected to an a.c. source of emf.

$$\epsilon = \epsilon_0 \sin \omega t \quad \dots (10.4.15)$$

The voltage equation to the circuit shown in fig. 10.20 is given as

$$L \frac{di}{dt} + Ri + \frac{q}{c} = \epsilon = \epsilon_0 \sin \omega t \quad \dots (10.4.16)$$

We know that $i = \frac{dq}{dt}$, therefore differentiating both side of eqn. 10.4.16 we obtain:

$$L \frac{d^2i}{dt^2} + R \frac{di}{dt} + \frac{i}{c} = \epsilon_0 \omega \cos \omega t \quad \dots (10.4.17)$$

Equation 10.4.17 is an *inhomogeneous* differential equation. In general it admits two solutions I_c (complimentary) and i_p (particular) which satisfy the differential equations as given below.

$$L \frac{d^2i_c}{dt^2} + R \frac{di_c}{dt} + \frac{i_c}{c} = 0 \quad \dots (10.4.18)$$

$$L \frac{d^2i_p}{dt^2} + R \frac{di_p}{dt} + \frac{i_p}{c} = \epsilon_0 \omega \cos \omega t \quad \dots (10.4.19)$$

But solution i_c of eqn.10.4.18 (called a transitory solution) decays with time. Hence i_p should be accepted as the steady state solution and i_c be neglected. Therefore we solve the equation 10.4.19 and put $i_p = i$ as our steady state solution of eqn.10.4.17. Now let us assume the solution to be

$$i = i_0 \sin(\omega t + \theta) \quad \dots (10.4.20)$$

Then $\frac{di}{dt} = i_0 \omega \cos(\omega t + \theta) \quad \dots (10.4.21)$

$$\frac{d^2i}{dt^2} = -i_0 \omega^2 \sin(\omega t + \theta) \quad \dots (10.4.22)$$

Using equation 10.4.20, 21 and 22 in eqn. 10.4.17 we get

$$\begin{aligned}
 & -Li_0\omega^2 \sin(\omega t + \theta) + Ri_0 \cos(\omega t + \theta) \\
 & + \frac{1}{C}i_0 \sin(\omega t + \theta) = \varepsilon_0 \omega \cos \omega t \\
 \Rightarrow & Li_0\omega^2 + R \cos(\omega t + \theta) \\
 & \text{----(10.4.23)}
 \end{aligned}$$

Define: $X_L = \omega L$, and $X_C = \frac{1}{\omega C}$ and

$R = Z \cos \phi$, $(X_C - X_L) = Z \sin \phi$ so that

$$\begin{aligned}
 Z &= \sqrt{R^2 + (X_C - X_L)^2}, \text{ and} \\
 \tan \phi &= \frac{(X_C - X_L)}{R} \text{ ----(10.4.24)}
 \end{aligned}$$

and use it in 10.4.23 to obtain

$$\begin{aligned}
 & i_0 [Z \cos \phi \cos(\omega t + \theta) + Z \sin \phi \sin(\omega t + \theta)] \\
 & = \varepsilon_0 \cos \omega t \\
 \Rightarrow & i_0 Z [\cos(\omega t + \theta - \phi)] = \varepsilon_0 \cos \omega t \text{ ----(10.4.25)}
 \end{aligned}$$

Comparing LHS and RHS of equation.10.4.25 we obtain

$$i_0 = \varepsilon_0 / Z \text{ and } \theta = \phi \text{ ----(10.4.26)}$$

Using the result given in equation 10.4.26 in 10.4.25

$$\begin{aligned}
 i &= \frac{\varepsilon_0}{Z} \sin(\omega t + \phi) \\
 &= \frac{\varepsilon_0}{\sqrt{R^2 + (X_C - X_L)^2}} \sin(\omega t + \phi) \text{ ----(10.4.27)}
 \end{aligned}$$

From equation 10.4.15 and 10.4.27, we find that the current i and applied emf ε differ in phase by ϕ . Equation 10.4.24 shows: (i) if $X_C > X_L$, then ϕ is positive and we say that current leads the applied emf in phase by ϕ ; (ii) if $X_C < X_L$,

then ϕ is negative and we conclude that current lags behind the applied emf in phase by ϕ .

Power

The instantaneous power P in R - L - C circuit is obtained by the product of instantaneous emf and instantaneous current. Thus,

$$\begin{aligned}
 P &= \varepsilon i = \varepsilon_0 \sin \omega t \cdot I_0 \sin(\omega t + \phi) \\
 &= \varepsilon_0 I_0 \sin \omega t [\sin \omega t \cos \phi + \cos \omega t \sin \phi] \\
 &= \frac{\varepsilon_0 I_0}{2} [2 \sin^2 \omega t \cos \phi \\
 &\quad + 2 \sin \omega t \cos \omega t \sin \phi]
 \end{aligned}$$

$$\Rightarrow P = \frac{\varepsilon_0 I_0}{2} [\cos \phi (1 - \cos 2\omega t) + \sin 2\omega t \sin \phi]$$

The average power (or True power) over a complete cycle is obtained as

$$\begin{aligned}
 P_{av} &= \frac{1}{T} \int_0^T P(t) dt \\
 &= \frac{1}{T} \int_0^T \left[\frac{\varepsilon_0 I_0}{2} \{ \cos \phi (1 - \cos 2\omega t) \right. \\
 &\quad \left. + \sin \phi \sin 2\omega t \} dt \right] \\
 &= \frac{1}{T} \int_0^T \frac{\varepsilon_0 I_0}{2} \cos \phi dt \\
 &\quad - \frac{\varepsilon_0 I_0}{2T} \int_0^T (\cos \phi \cos 2\omega t - \sin \phi \sin 2\omega t) dt \\
 &= \frac{1}{T} \left(\frac{\varepsilon_0 I_0}{2} \cos \phi \cdot T \right) - \frac{\varepsilon_0 I_0}{2T} \int_0^T \{ \cos(2\omega t + \phi) \} dt \\
 &= \frac{\varepsilon_0 I_0}{2} \cos \phi - 0
 \end{aligned}$$

$$\Rightarrow P_{av} = \frac{\varepsilon_0 I_0}{2} \cos \phi \quad \dots 10.4.15$$

$$\begin{aligned}
 \Rightarrow P_{av} &= \frac{\varepsilon_0}{\sqrt{2}} \cdot \frac{I_0}{\sqrt{2}} \cos \phi \\
 &= \varepsilon_{eff} \cdot I_{eff} \cos \phi \quad \dots 10.4.16
 \end{aligned}$$

Thus we see that the average or true power in an a.c. circuit in general, is expressed as the product of effective values of emf and current and a factor $\cos \phi$, known as the **power factor**. The power factor (p.f.) depends on the phase lag/lead of current behind/over emf in an a.c. circuit. Its value depends on the resistance R and impedance Z of the circuit and is obtained as

$$\text{p.f.} = \cos \phi = \frac{R}{Z} \quad \dots 10.4.17$$

One may deduce it from eq. 10.4.11. How ?

We have seen earlier that the product of effective values of emf and current is called the **reactive power** P_R or **apparent power** of an a.c. circuit i.e.

$$P_R = \epsilon_{\text{eff}} \cdot I_{\text{eff}}$$

We see from eq. 10.4.16 that

$$P_{\text{av}} = P_R \cdot \cos \phi$$

$$\begin{aligned} \text{i.e.} \quad \text{p.f.} = \cos \phi &= \frac{P_{\text{av}}}{P_R} \\ &= \frac{\text{true power}}{\text{apparent power}} \quad \dots 10.4.18 \end{aligned}$$

Further we see from phasor diagrams that the component of peak current along ϵ_o is $I_o \cos \phi$ in a.c. circuits in general. This component is used in finding the true power and is called the **active or wattful component** of a.c. The component $I_o \sin \phi$ at right angles to ϵ_o has no contribution to find the true power of the a.c. circuit and hence is called the **idle or wattless component** of a.c.

In purely reactive circuits such as L , C or $L - C$ circuits having negligible resistance, the current is entirely wattless since $\phi = \pi / 2$, and no power is required to maintain the current in any reactor.

Reactors are used in storing energy. An inductor stores energy in its magnetic field and the energy is $\frac{1}{2} LI_o^2$.

A capacitor stores energy in its electrostatic field in between the plates and the energy is $\frac{1}{2} \frac{q_o^2}{C}$.

Table 10.1

a.c. ckt containing	ϕ phase difference betwn. I & ϵ	Z impedance	power factor = $\cos \phi$	true power	Nature of circuit
R only	0	0	1	$\epsilon_{\text{eff}} \cdot I_{\text{eff}}$	dissipative
L only	$-\pi/2$	ωL	0	0	reactive
C only	$+\pi/2$	$\frac{1}{\omega C}$	0	0	reactive
R & L	$\tan^{-1} \left(-\frac{\omega L}{R} \right)$	$\sqrt{R^2 + \omega^2 L^2}$	$\cos \phi = \frac{R}{Z}$	$\epsilon_{\text{eff}} \cdot I_{\text{eff}} \cos \phi$	dissipative & reactive
R & C	$\tan^{-1} \left(\frac{1/\omega C}{R} \right)$	$\sqrt{R^2 + \frac{1}{\omega^2 C^2}}$	$\cos \phi = \frac{R}{Z}$	do	do
R, L & C	$\tan^{-1} \left(\frac{\frac{1}{\omega C} - \omega L}{R} \right)$	$\sqrt{R^2 + \left(\frac{1}{\omega C} - \omega L \right)^2}$	$\cos \phi = \frac{R}{Z}$	do	do

Series resonance

When a sinusoidal emf of variable frequency is applied to an a.c. circuit containing R, L and C in series, the impedance Z of the circuit changes with ω . This results in variation of the peak current I_0 of the circuit.

$$\therefore I_0 = \frac{\epsilon_0}{\sqrt{R^2 + \left(\frac{1}{\omega C} - \omega L\right)^2}}$$

it becomes maximum when

$$\begin{aligned} \frac{1}{\omega C} &= \omega L \\ \Rightarrow \omega &= \sqrt{\frac{1}{LC}} \quad \dots 10.4.19 \end{aligned}$$

The corresponding a.c. frequency $f = f_r$ is given by

$$f_r = \frac{1}{2\pi} \sqrt{\frac{1}{LC}} \quad \dots 10.4.20$$

This frequency f_r is called the **resonant frequency** of the a.c. circuit for given values of L and C. The peak current at resonance of the

circuit is $I_{0(\text{res})} = \frac{\epsilon_0}{R}$ and the reactance is zero.

The variation of peak current I_0 with f is shown in Fig. 10.22 for two different values of R, but for the same values of L and C.

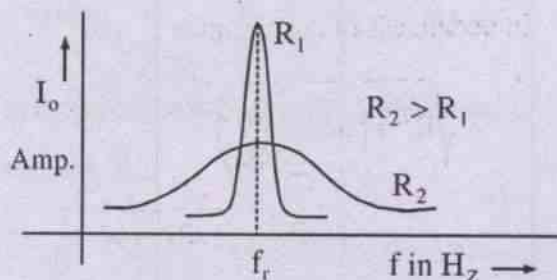

Fig. 10.22

(Variation of I_0 with f)

It is seen that, the resonance is sharp when R is small. In other words when f is close to f_r , the current is high. An LCR circuit used at a frequency close to resonant frequency is called a **resonant circuit**. The tuning circuit of radio or television is an example of resonant circuit. The tuning of a radio means to adjust the values of C for given values of R and L to obtain the resonant frequency corresponding to the frequency at which signal is transmitted from the transmitting station.

The power factor of a resonant RLC circuit is unity.

Example 10.4.1

A 100 ohm resistor and 1H inductor are connected in series to an a.c. source of peak voltage 220V and frequency 50 Hz. Find (a) the impedance (b) peak value of current (c) phase angle between voltage and current (d) power factor (e) peak voltage across the inductor and the resistor.

Soln.

$$\begin{aligned} \text{Given } R &= 100 \text{ ohm} \\ L &= 1 \text{ H} \\ \epsilon_0 &= 220 \text{ V} \\ f &= 50 \text{ Hz} \end{aligned}$$

We have

$$\begin{aligned} \text{(a) Impedance } Z &= \sqrt{R^2 + \omega^2 L^2} \\ &= \sqrt{100^2 + (100\pi)^2} \\ &= 3290.7 \text{ ohm} \end{aligned}$$

$$\begin{aligned} \text{(b) Peak value of current} &= I_0 \\ &= \frac{\epsilon_0}{Z} \\ &= \frac{220\text{V}}{3290.7 \text{ ohm}} = 0.67\text{A} \end{aligned}$$

(c) Phase angle between voltage and current

$$\phi = \tan^{-1} \frac{\omega L}{R}$$

$$= \tan^{-1} \frac{100\pi \text{H/s}}{100 \text{ ohm}} = \tan^{-1} \pi$$

$$\Rightarrow \phi = 72.34^\circ$$

(d) Power factor = $\cos\phi = \cos 72.34^\circ = 0.3$

(e) Peak voltage across the resistor = $I_0 R$
 $= 67 \text{ volt}$

Peak voltage across the inductor
 $= I_0 \omega L = 210 \text{ volt}$

Example 10.4.2

A resistance of 50Ω and a capacitance of $50 \mu\text{F}$ are connected in series to an a.c. source of emf 230 V and frequency 50 Hz . Find the impedance, the peak value of current, phase angle, power factor and peak voltage across R and C .

Soln.

Given $R = 50 \Omega$
 $C = 50 \mu\text{F} = 50 \times 10^{-6} \text{ F}$
 $\epsilon_{\text{eff}} = 230 \text{ V}$
 $f = 50 \text{ Hz}$

We have

(a) Impedance $Z = \sqrt{R^2 + \left(\frac{1}{\omega C}\right)^2}$
 $= \sqrt{50^2 + \frac{1}{(2 \times \pi \times 50 \times 50 \times 10^{-6})^2}}$
 $= \sqrt{2500 + 4053} = 80.95\Omega = 81 \text{ ohm}$

(b) Peak emf = $\epsilon_o = \sqrt{2} \epsilon_{\text{eff}} = 230\sqrt{2} \text{ V}$
 $= 325.27 \text{ V}$

\therefore Peak current = $I_o = \epsilon_o / Z = \frac{325.27}{81} \text{ A}$
 $= 4.02\text{A} = 4\text{A}$

(c) Phase angle $\phi = \tan^{-1} \frac{1/\omega C}{R}$
 $= \tan^{-1} \left(\frac{1}{\omega CR}\right) = \tan^{-1} \left(\frac{1}{2\pi f CR}\right)$
 $= \tan^{-1} \frac{1}{(2 \times \pi \times 50 \times 50 \times 10^{-6} \times 50)}$
 $= \tan^{-1}(1.27324)$
 $= 51.85^\circ$

(d) Power factor = $\cos\phi = \cos 51.85^\circ = 0.62$

(e) Peak voltage across $R = I_0 R = 4\text{A} \times 50$
 $= 200 \text{ V}$

Peak voltage across $C = I_o \left(\frac{1}{\omega C}\right)$
 $= 4\text{A} \times 63.66 = 254.64 \text{ V}$

Example 10.4.3

The resistance, inductive reactance and capacitive reactance in an a.c. circuit are 30Ω , 20Ω and 60Ω respectively. Find (a) the impedance of the circuit, (b) the phase relationship between voltage and current and (c) its power factor.

Soln.

Given $R = 30\Omega$
 $\omega L = R_L = 20\Omega$
 and $\frac{1}{\omega C} = R_C = 60\Omega$

\therefore Impedance Z of the circuit =

$$\sqrt{R^2 + \left(\omega L - \frac{1}{\omega C}\right)^2}$$

$$= \sqrt{(30)^2 + \{(20) - (60)\}^2}$$

$$= \sqrt{900 + 1600}$$

$$= \sqrt{2500} = 50 \text{ ohm}$$

(b) The phase angle ϕ between current and emf is given by

$$\begin{aligned}\phi &= \tan^{-1} \left(\frac{R_C - R_L}{R} \right) \\ &= \tan^{-1} \left(\frac{60 - 20}{30} \right) \\ &= \tan^{-1} \left(\frac{4}{3} \right)\end{aligned}$$

i.e. $\phi = \tan^{-1} 1.333 = 53.13^\circ$

Here current leads the voltage by 53.13°

(c) Power factor = $\cos \phi = \cos 53.13^\circ = 0.6$

10.5 Simple a.c. devices

In this section let us discuss the functions and uses of some simple a.c. devices in a nutshell.

(a) A choke coil

Sometimes it is required to reduce the current in a circuit to save some appliances from damage. In d.c. circuits this is done by using extra resistors at the cost of loss of energy. But in a.c. circuits this can be done by using an inductor in series with the appliance without any loss of energy. Choke coil is an example of the same.

It is a coil having appreciable inductance but small resistance and is used in series with fluorescent mercury tube fittings to reduce the current. The tubes are, thereby, saved from damage. The choke is fixed in the tube-light fitting to which the tube is connected [Fig. 10.23 (a)]. The tube itself acts as the resistor whereas the choke coil in series with it acts as the inductor.

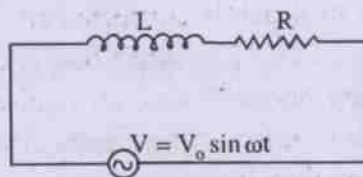

(a)

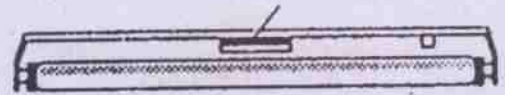

(b)

Fig. 10.23

(choke coil and its connection in a.c. circuit)

The equivalent circuit is shown in Fig. 10.23 (b). Its impedance $Z = \sqrt{R^2 + \omega^2 L^2}$. Assuming the applied voltage $V = V_0 \sin \omega t$, the peak current through the choke and the tube is

$$I_0 = \frac{V_0}{\sqrt{R^2 + \omega^2 L^2}}$$

Hence $I_{\text{eff}} = \frac{I_0}{\sqrt{2}} = \frac{V_0 / \sqrt{2}}{\sqrt{R^2 + \omega^2 L^2}}$ and

the effective voltage across the resistor is

$$RI_{\text{eff}} = \frac{R}{\sqrt{R^2 + \omega^2 L^2}} \cdot V_{\text{eff}}$$

Without the choke, voltage across the tube is V_{eff} . Thus the voltage is reduced by a factor $\frac{R}{\sqrt{R^2 + \omega^2 L^2}}$ by using the choke and hence the current. This saves power too as use of inductor does not necessitate any power.

In high frequency a.c. circuits choke coil with air core is used whereas in low frequency a.c. chokes with iron core are used.

(b) A.C. measuring instruments

Average values of a.c. over a complete cycle is zero and therefore alternating current or voltage cannot be measured by d.c. ammeters or voltmeters. The making of such instruments depends on the fact that average value of I^2 is not zero over a complete cycle of a.c. The deflection of these instruments is seen to be proportional to I^2 and these instruments are otherwise called hot wire instruments.

In a hot wire ammeter, a platinum-iridium wire AB is fixed tightly between two

its associated induced electric field. The primary and the secondary are wound on the same core to minimise flux leakage. The transformer is named **step up** or **step down** according as the **number of turns in the secondary windings is more or less than those in the primary.**

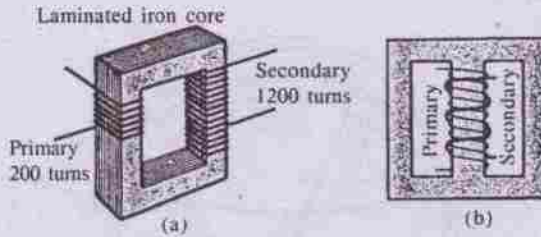

Fig. 10.26 (a transformer)

The core material is chosen to have high magnetic permeability, low hysteresis loss and large specific resistance. It is laminated to minimize loss of energy due to eddies. The material is usually called transformer steel.

Working

Let us consider an ideal transformer in which there are no losses and the total magnetic flux is confined to the iron core. Hence the same flux links both the primary and the secondary. It is assumed that N_p turns of the primary and N_s turns of the secondary, both encircle the core in the same sense.

Let the primary be connected to an a.c. source of instantaneous voltage V_p and let the secondary be open. Then there is no current in the secondary and the primary works merely as an inductor. The primary current is small because of the back emf produced in it and the current lags behind the voltage by $\pi/2$. It is the magnetizing current and the power-input (due to it) to the transformer is zero (why?).

As the primary current is alternating, the flux through the core is alternating too, being in phase with the current. Let ϕ be the instantaneous flux linking each turn of the primary and the secondary. Then the flux linking the primary at the instant is $N_p\phi$ and the

magnitude of the induced emf ε_p produced in it due to the changing flux is given by

$$|\varepsilon_p| = N_p \frac{d\phi}{dt} \quad \dots 10.6.1$$

By assumption the resistance of the windings is nearly zero so that $|\varepsilon_p|$ equals V_p at every instant to maintain the charge flow.

$$\text{Hence } V_p = |\varepsilon_p| = N_p \frac{d\phi}{dt} \quad \dots 10.6.2$$

The instantaneous flux linking the secondary is $N_s\phi$ and the magnitude of induced emf developed due to it across the secondary is given by

$$|\varepsilon_s| = N_s \frac{d\phi}{dt} \quad \dots 10.6.3$$

$|\varepsilon_s|$ also equals V_s and therefore

$$V_s = |\varepsilon_s| = N_s \frac{d\phi}{dt} \quad \dots 10.6.4$$

From eqns. 10.6.2 and 10.6.4, we have

$$\frac{V_s}{V_p} = \frac{N_s}{N_p} \quad \dots 10.6.5$$

Thus by properly choosing the **turn ratio** $\frac{N_s}{N_p}$, the desired secondary voltage may be obtained from a given primary voltage.

When $V_s > V_p$, we have the **step up transformer**

When $V_s < V_p$, we have the **step down transformer.**

Let us now see what happens when the secondary circuit is closed. A current I_s is now maintained in the secondary circuit. Its phase angle ϕ_s depends on the nature of the circuit. Now some power is delivered by the secondary except when $\phi_s = 90^\circ$. This necessitates an

fixed ends A & B (Fig. 10.24). A spring is fixed at one end C and is permanently connected to a thin wire at the other end. The thin wire is wound several times over a cylinder D and its end is connected to the mid point of AB. The cylinder can rotate about its axis. A pointer fixed to the cylinder can move along a graduated scale when the cylinder rotates. A shunt r (low resistance) is connected parallel to AB. This makes the ammeter a low resistance device. The points A and B are connected to the outer terminals T_1 and T_2 .

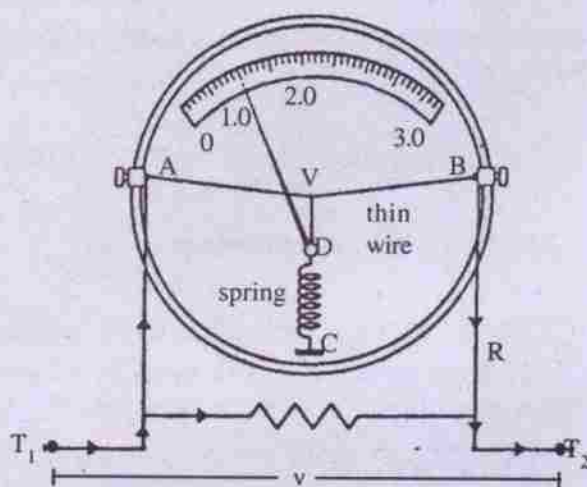

Fig. 10.24 (a.c. ammeter)

The current to be measured is passed through T_1 and T_2 . As current is passed, AB gets heated and the rise of temperature becomes proportional to I_{eff}^2 . The wire gets elongated and its tension decreases. It increases the tension of the spring on the otherside so that the cylinder rotates a little resulting in deflection θ of the pointer on the scale. θ is proportional to I_{eff}^2 . However, the graduations on the scale are such that the reading gives directly the value of I_{rms} . It is precalibrated.

A.C. voltmeter is almost identical to a.c. ammeter except that a high resistance R is connected in series with the wire AB replacing r (Fig. 10.25). The alternating voltage to be

measured is applied across T_1 and T_2 so that the current deflects the pointer on the scale. Here deflection θ is proportional to V_{rms}^2 . However, the calibrations are such that it directly measures V_{rms} .

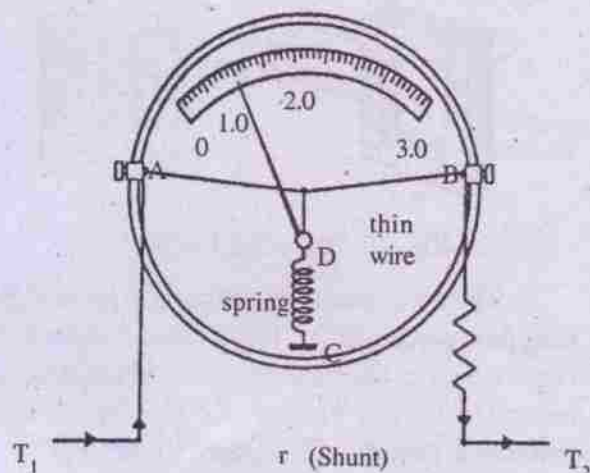

Fig. 10.25 (a.c. voltmeter)

10.6 Transformer

A transformer is an electrical device either to increase or decrease a.c. voltages as per requirement, which is not otherwise possible in case of d.c. **It works on the principle of electromagnetic induction** and is used in a variety of cases starting from long distance transmission of power to the operation of many simple electrical and electronic devices.

Construction

A transformer consists of two coils electrically insulated from each other and wound on the same laminated soft iron core (Fig. 10.26). One of the coils is called the primary to which is connected an alternating source of emf. The other one is called the secondary across which an induced emf is developed due to varying current in the primary. Energy is thus transferred from the primary windings to the secondary via the core flux and

its associated induced electric field. The primary and the secondary are wound on the same core to minimise flux leakage. The transformer is named **step up** or **step down** according as the **number of turns in the secondary windings is more or less than those in the primary.**

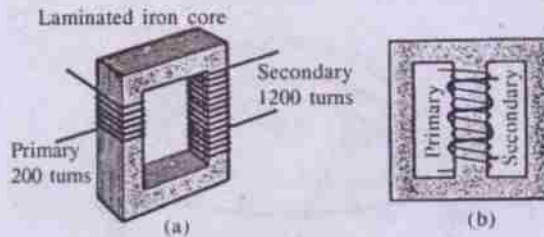

Fig. 10.26 (a transformer)

The core material is chosen to have high magnetic permeability, low hysteresis loss and large specific resistance. It is laminated to minimize loss of energy due to eddies. The material is usually called transformer steel.

Working

Let us consider an ideal transformer in which there are no losses and the total magnetic flux is confined to the iron core. Hence the same flux links both the primary and the secondary. It is assumed that N_p turns of the primary and N_s turns of the secondary, both encircle the core in the same sense.

Let the primary be connected to an a.c. source of instantaneous voltage V_p and let the secondary be open. Then there is no current in the secondary and the primary works merely as an inductor. The primary current is small because of the back emf produced in it and the current lags behind the voltage by $\pi/2$. It is the magnetizing current and the power-input (due to it) to the transformer is zero (why?).

As the primary current is alternating, the flux through the core is alternating too, being in phase with the current. Let ϕ be the instantaneous flux linking each turn of the primary and the secondary. Then the flux linking the primary at the instant is $N_p\phi$ and the

magnitude of the induced emf ε_p produced in it due to the changing flux is given by

$$|\varepsilon_p| = N_p \frac{d\phi}{dt} \quad \dots 10.6.1$$

By assumption the resistance of the windings is nearly zero so that $|\varepsilon_p|$ equals V_p at every instant to maintain the charge flow.

$$\text{Hence } V_p = |\varepsilon_p| = N_p \frac{d\phi}{dt} \quad \dots 10.6.2$$

The instantaneous flux linking the secondary is $N_s\phi$ and the magnitude of induced emf developed due to it across the secondary is given by

$$|\varepsilon_s| = N_s \frac{d\phi}{dt} \quad \dots 10.6.3$$

$|\varepsilon_s|$ also equals V_s and therefore

$$V_s = |\varepsilon_s| = N_s \frac{d\phi}{dt} \quad \dots 10.6.4$$

From eqns. 10.6.2 and 10.6.4, we have

$$\frac{V_s}{V_p} = \frac{N_s}{N_p} \quad \dots 10.6.5$$

Thus by properly choosing the **turn ratio** $\frac{N_s}{N_p}$, the desired secondary voltage may be obtained from a given primary voltage.

When $V_s > V_p$, we have the **step up transformer**

When $V_s < V_p$, we have the **step down transformer.**

Let us now see what happens when the secondary circuit is closed. A current I_s is now maintained in the secondary circuit. Its phase angle ϕ_s depends on the nature of the circuit. Now some power is delivered by the secondary except when $\phi_s = 90^\circ$. This necessitates an

equal amount of power to be supplied to the primary circuit. It is accomplished as follows.

When the secondary circuit is closed, the flux in the core is produced by both the primary and the secondary currents. The secondary current tends to weaken the core flux by Lenz's law and thus decreases the back emf in the primary. The primary current, thereby, increases.

When the secondary circuit is completed by a load of resistance R , $I_S = V_S / R$. Since power delivered to the primary is equal to that taken out of the secondary (assuming no loss of power)

$$V_P I_P = V_S I_S \quad \dots 10.6.6$$

$$\Rightarrow \frac{V_S}{V_P} = \frac{I_P}{I_S} \quad \dots 10.6.7$$

From eqs. 10.6.5 and 10.6.7, we have

$$\frac{I_S}{I_P} = \frac{N_P}{N_S} \quad \dots 10.6.8$$

i.e.
$$\frac{I_S}{I_P} = \frac{1}{N_S / N_P} = \frac{1}{\text{turn ratio}} \quad \dots 10.6.9$$

Thus in an ideal transformer the ratio of the secondary current to the primary current varies inversely as the turn ratio. The voltage in the secondary is gained in a step up transformer at the cost of secondary current. The reverse is the case in a step down transformer.

We have considered the ideal case only in which there is no loss of the supplied power to a transformer. In the practical cases, however, the losses are unavoidable. These include mainly the **ohmic loss** (I^2R), the **hysteresis loss** and the **eddy current loss**. With attempts to minimize the losses, the efficiency of the transformer increases. Hence in practical cases we may have transformers with efficiency nearly 90% or above.

The losses in a transformer

Energy fed to a transformer is lost to some extent in the following three ways.

(a) Copper (or Joule) loss

Though made up of copper, the windings of the primary and the secondary have some resistance and joule heat is developed when current is maintained in these coils. This loss ($= I^2 R t$) cannot be completely eliminated. However, it is minimized by using low resistance coils (i.e. thicker wires) of copper.

(b) Eddy current loss (Iron loss)

Due to change of magnetic flux linking the iron core induced eddies are formed through the solid block of the core. These eddy current loops produce unnecessary heating in the core. Such a loss of energy is called the **eddy current loss** or **iron loss**. It is minimized to a great extent by using laminated core of iron in place of solid block.

(c) Hysteresis loss

The iron core gets magnetized during the +ve half cycle of the a.c. and is demagnetized during the -ve half cycle. However, the demagnetization is not complete and some magnetism is retained in the core in a complete cycle. Such **retention of magnetism** in the core is called **hysteresis** and in the process some energy is lost which appears as heat. Hence the loss of energy is called **hysteresis loss**, which depends on the nature of the material of the core. It is minimum for soft iron. Hence the core of the transformer is made of soft iron (laminated) to minimise hysteresis loss.

(d) Loss due to flux leakage

The whole of magnetic flux produced by the primary may not link the secondary or vice versa. Hence there is some leakage of flux. It is due to manufacture defect. The energy loss during the process is called loss due to flux leakage. It is minimized by proper winding of the coil on the core.

Uses of transformer

- (i) The most important use of transformer is in the long distance transmission of

electricity from the generating stations through cables. Here step up transformers are used to increase the voltage to kilovolt order and reduce the current so that the heat loss (I^2Rt) in the cables are minimized by appreciable amount. Hence a lot of energy is made available at distant places. However, from safety point of view and insulation of moving parts it is required to work with desired low voltages, which is brought about by step down transformers at substations, set up at different places.

- (ii) Transformers are used in machines working on a.c. It is used in telephone, telegraph and wireless transmitting and receiving sets, television, electrical welding machines, electric furnaces etc.

10.7 LC Oscillatrons :

The circuit shown below describes the mechanism of L-C oscillation. The capacitor C and inductor L are connected through a key K. There is an arrangement of a battery 'E' and key K₁, to charge the capacitor. It is to be noted that the capacitor and inductor store electrical and magnetic energy respectively.

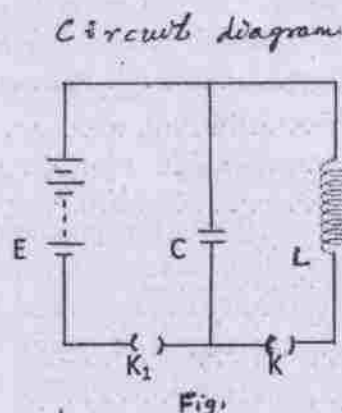

Let the key K₁ is closed keeping the key K open. The capacitor is now charged. If q_0 is the maximum charge on the capacitor, then the electrical energy stored in it is

$$e_0(U_c)_{\max} = \frac{1}{2} q_0^2 \quad \text{-----10.7.1}$$

The key K₁ is now made open and the key K is closed. The capacitor starts discharging through the inductor, giving rise to the current in the circuit. The current flow giving rise to the current in the circuit. The current flow sets up a magnetic field around the inductor. This current increases to a maximum value I_0 for which the magnetic energy in the inductor is

$$(U_m)_{\max} = \frac{1}{2} LI_0^2 \quad \text{.....10.7.2}$$

When the current in the inductor is maximum, the capacitor becomes fully discharged and electrical energy in the capacitor is zero. In other words electrical energy across the capacitor has been fully converted to magnetic energy across the inductor. At this stage, the magnetic field now starts decreasing and the current starts charging the capacitor but in opposite director. Finally the magnetic field completely collapses and capacitor becomes fully charged. We can view this as the transformation of magnetic energy in the inductor to the electrical energy in the capacitor.

From the above discussion we see that the energy alternately changes from electrical to magnetic across capacitor and inductor respectively. This type of oscillation of energy between 'L' and 'C' is called LC oscillation.

Mathematical analysis

We take the time at which the capacitor is fully charged (q_0) as the initial time ($t=0$). As the key 'K' is closed, the capacitor starts discharging and a current is built up in the circuit. Let at any instant t , the charge in the capacitor is ' q ' and current through the inductor is ' I '.

Total energy in the circuit is

$$U = U_c + U_m = \frac{1}{2} \frac{q^2}{C} + \frac{1}{2} LI^2 \quad \text{---(i)}$$

If we consider that there is no loss of energy (which is not possible practically), V is constant.

Then $\frac{du}{dt} = 0$
 $\Rightarrow \frac{q}{C} \frac{dq}{dt} + LI \frac{dI}{dt} = 0$ -----(ii)

But $\frac{dq}{dt} = I$ and $\frac{dI}{dt} = \frac{d^2q}{dt^2}$

Then from eqn. (ii)

$$\frac{q}{C} I + LI \frac{d^2q}{dt^2} = 0 = LI \left(\frac{q}{LC} + \frac{d^2q}{dt^2} \right)$$

But if I=0 it will imply q=constant. which is physically incorrect, so

$$\Rightarrow \frac{q^2}{dt^2} + \frac{1}{LC} q = 0$$
 -----(10.7.3)

This equation is equivalent to the equation.

$$\frac{d^2y}{dt^2} + w^2 y = 0$$
 -----(10.7.4)

Which represents simple harmonic oscillation of frequency w.

Thus the charge 'q' oscillates with a natural frequency*.

$$w = \frac{1}{\sqrt{LC}}$$
 -----(10.7.5)

The solution of the differential equation (10.7.3) is

$$q = q_0 \cos(\omega t + \delta)$$
 -----(10.7.6)

comparing 10.7.3 and 10.7.4

$$\omega^2 = \frac{1}{LC} \Rightarrow \omega = \frac{1}{\sqrt{LC}}$$

As we have taken q=q₀ at t=0, we have δ = 0. Equation 10.7.6 may then be written as:

$$q = q_0 \cos \omega t$$
 -----(10.7.7)

In terms of current;

$$I = \frac{dq}{dt} = -q_0 \omega \sin \omega t.$$

or I₀ = -q₀ω is the peak value of current.

From equations (10.7.7) and (10.7.8), we see that the charge and current oscillate with a natural frequency. However such type of constant undamped oscillation is not possible for the following two reasons.

1. Every inductor has some resistance for which there is a loss of energy in the coil.

2. There is also a radiation loss from the circuit in the form of electromagnetic waves.

Thus amplitude of scillation decreases and finally dies away. To maintain a constant amplitude appropriate amount of energy must be supplied at proper time intervals in current phase. A practical oscillator has such an arrangement so that continuous undamped oscillations can be produced.

Displacement Current :

Ampere's circuital law states that the line integral of magnetic induction \vec{B} around any closed path is equal to μ_0 times the current (I) across the area bounded by this path.

$$\oint \vec{B} \cdot d\vec{l} = \mu_0 I$$
 -----(1)

This equation is valid for steady current i.e. when electric field at the surface is constant with time however this law fails when electric field at the surface changes with time. In other words Ampere's law was limited only to the situation of a constant electric field. James Clerk Maxwell generalised this law to include time-varying electric field. He introduced a new term in the r.h.s. of equation (1) in order to account for the non-steady situation.

The modified Ampere's law is then:

$$\oint \vec{B} \cdot d\vec{l} = \mu_0 I + \mu_0 \epsilon_0 \frac{d\theta_E}{dt}$$

Ex. 10.3 :

The overall efficiency of a transformer is 90%. It is rated for an output of 12.5 KW. The primary voltage is 1100 V. The ratio of primary to secondary turns is 5:1. If the iron losses at full load are 700 watts and the resistance of the primary coils is 1.82 ohms, how much power is lost because of the resistance of the primary coils? Find the resistance of the secondary coils.

Soln.

Given,

efficiency of the transformer, $\eta = 90\% = 0.9$

$P_o =$ output power = 12.5 k. watt = 12500 watt

$$P_i = \text{input power} = \frac{\text{output power}}{\eta} = \frac{12500 \text{ watt}}{0.9} = 13888.9 \text{ watt}$$

$$\therefore V_p I_p = P_i$$

$$I_p = \frac{P_i}{V_p} = \frac{13888.9 \text{ watt}}{1100 \text{ volt}} = 12.626 \text{ A}$$

$$\therefore R_p = 1.82 \text{ ohm}$$

Loss in primary as heat = $I_p^2 R_p = 290.14 \text{ watt}$

$$\begin{aligned} \text{Total loss of power} &= 13888.89 - 12500 \\ &= 1388.89 \text{ watt} \end{aligned}$$

Total Iron loss = 700 watt

$$\begin{aligned} \therefore \text{Total copper loss} &= 1388.9 - 700 \\ &= 688.89 \text{ watt} \end{aligned}$$

$$\begin{aligned} \therefore \text{Copper loss in secondary} &= \\ &= (688.89 - 290.14) \text{ watt} \\ &= 398.75 \text{ watt} \end{aligned}$$

$$\therefore \frac{V_s}{V_p} = \frac{N_s}{N_p} = \frac{1}{5}$$

$$V_s = \frac{1}{5} V_p = \frac{1}{5} \times 1100 \text{ volt} = 220 \text{ volt}$$

$$\therefore I_s = \frac{P_o}{V_s} = \frac{12500}{220} = 56.82 \text{ A}$$

\therefore Copper loss in secondary =

$$I_s^2 R_s = (56.82)^2 R_s \text{ A}^2$$

$$\therefore R_s = \frac{I_s^2 R_s}{I_s^2} = \frac{398.75 \text{ watt}}{(56.82)^2 \text{ A}^2} = 0.124 \text{ ohm}$$

Ex. 10.4 :

A 60 cycle a.c. circuit has a voltage of 120 V and a current of 6 A. Find the maximum values of these quantities and the instantaneous voltage $\frac{1}{720}$ S after the voltage has zero start.

Soln.

Given $f = 60 \text{ Hz}$

$$V_{\text{eff}} = 120 \text{ V}$$

$$\text{and } I_{\text{eff}} = 6 \text{ A}$$

$$\therefore V_o = V_{\text{eff}} \cdot \sqrt{2} = 120 \text{ V} \cdot \sqrt{2} = 169.68 \text{ volt}$$

$$\text{and } I_o = I_{\text{eff}} \cdot \sqrt{2} = 6 \sqrt{2} \text{ A} = 8.48 \text{ A}$$

Let us take $V = V_o \sin \omega t$, so that

$$\begin{aligned} V_{\text{ins}} \left(\text{after } \frac{1}{720} \text{ sec} \right) &= V_o \sin \omega t \\ &= 169.68 \text{ V} \sin 2\pi f t \\ &= 169.68 \text{ V} \sin 2\pi \times 60 \text{ s} \times \frac{1}{720 \text{ s}} \\ &= 169.68 \text{ V} \sin \frac{\pi}{6} = 169.68 \times \frac{1}{2} \text{ V} \\ &= 84.84 \text{ V} \end{aligned}$$

Ex. 10.5 :

A choke coil has a resistance of 4 ohms and self inductance of 2390 μH . It is connected to a source of 500 cycle 110 V alternating emf. Find the reactance, impedance and current of the circuit.

Soln.

Given $R = 4 \text{ ohm}$
 $L = 2390 \mu\text{H}$
 $= 2390 \times 10^{-6} \text{ H} = 0.00239 \text{ H}$
 $f = 500 \text{ cps} = 500 \text{ Hz}$

$$\therefore \omega = 2\pi f = 2\pi \times 500 \text{ per sec} = 1000\pi / \text{s}$$

$$V_{\text{eff}} = 110 \text{ V}$$

$$\therefore V_o = 110\sqrt{2} \text{ V} = 155.56 \text{ V}$$

$$\text{Reactance} = \omega L = 1000 \frac{\pi}{\text{S}} \times 0.00239 \text{ H}$$

$$= 7.51 \text{ ohm}$$

$$\text{Impedance} = Z = \sqrt{R^2 + \omega^2 L^2} = \sqrt{4^2 + (7.51)^2}$$

$$= 8.51 \text{ ohm}$$

$$\text{Current} = I_{\text{eff}} = \frac{V_{\text{eff}}}{Z} = \frac{110 \text{ V}}{8.51 \text{ ohm}} = 12.93 \text{ A}$$

Ex. 10.6 :

Alternating emf $\varepsilon = 220 \sin 100\pi t$ is applied to a circuit containing an inductance of $\frac{1}{\pi}$ H. Write the equation for instantaneous current through the circuit. Find the peak value and r.m.s. value of current.

Soln.

Given $\varepsilon = 220 \sin 100\pi t$

$$\therefore \varepsilon_o = 220 \text{ V}$$

$$\omega = 100\pi$$

$$\therefore L = \frac{1}{\pi} \text{ H}$$

$$\therefore R_L = \omega L = 100\pi \times \frac{1}{\pi} = 100 \text{ ohm}$$

$$I_o = \frac{220 \text{ V}}{R_L} = \frac{220 \text{ V}}{100 \text{ ohm}} = 2.2 \text{ A}$$

$$I = I_o \sin(\omega t - \pi/2)$$

$$= 2.2 \sin(100\pi t - \pi/2)$$

$$I_{\text{rms}} = \frac{I_o}{\sqrt{2}} = \frac{2.2}{\sqrt{2}} = 1.556 \text{ A}$$

Ex. 10.7 :

The peak power consumed by a resistive coil when connected to an a.c. source is 80 watt. Find the energy consumed by the coil in 100 S which is many times larger than the time period of the source.

Soln.

$$\text{Power } P = \frac{1}{2} \varepsilon_o I_o \cos \phi$$

For a resistive circuit $\cos \phi = 1$, since $\phi = 0$.

$$\therefore P_{\text{av}} = \frac{1}{2} \varepsilon_o I_o \text{ over a cycle}$$

Thus $P_{\text{max}} = \varepsilon_o I_o = 80 \text{ watt}$

$$\therefore \text{Energy consumed in } 100 \text{ S} = P_{\text{av}} \times 100 \text{ S}$$

$$= \frac{\varepsilon_o I_o}{2} \times 100 \text{ S}$$

$$= \frac{80 \text{ watt}}{2} \times 100 \text{ S}$$

$$= 4000 \text{ J}$$

$$= 4 \text{ kJ}$$

Ex. 10.8 :

An inductance of 2H, a capacitance of $18 \mu\text{F}$ and a resistance of $10 \text{ K}\Omega$ are connected to an a.c. source of 20 V with adjustable frequency. What frequency should be chosen to get the maximum current and find the maximum value of the current.

Soln.

Given $R = 10 \text{ K}\Omega = 10000 \text{ ohm}$

$$L = 2 \text{ H}$$

$$C = 18 \mu\text{F} = 18 \times 10^{-6} \text{ F}$$

$$\epsilon_{\text{eff}} = 20 \text{ V}$$

$$\therefore \epsilon_0 = 20\sqrt{2} \text{ V}$$

\therefore Peak current I_0 in the circuit is given by

$$I_0 = \frac{\epsilon_0}{\sqrt{R^2 + \left(\frac{1}{\omega C} - \omega L\right)^2}}$$

When the frequency is adjustable I_0 becomes maximum for $\frac{1}{\omega C} - \omega L = 0$ i.e. $\frac{1}{\omega C} = \omega L$

Hence $\omega_r = \frac{1}{\sqrt{LC}}$

$$\Rightarrow 2\pi f_r = \frac{1}{\sqrt{LC}}$$

$$\Rightarrow f_r = \frac{1}{2\pi\sqrt{2\text{H} \times 18 \times 10^{-6}\text{F}}}$$

$$= \frac{1}{2\pi \times 6 \times 10^{-3} \text{ s}}$$

$$\Rightarrow f_r = \frac{1000}{12\pi} \text{ per sec} = 26.53 \text{ per sec}$$

$$\Rightarrow f_r \approx 27\text{Hz (resonant frequency)}$$

The maximum value of the peak current at resonance

$$= \frac{\epsilon_0}{R} = \frac{20\sqrt{2} \text{ V}}{10000 \text{ ohm}} = 2.83 \times 10^{-3} \text{ A}$$

The maximum value of r.m.s. current at resonance

$$= \frac{\epsilon_{\text{eff}}}{R} = \frac{20 \text{ V}}{10000 \text{ ohm}} = 2 \times 10^{-3} \text{ A} = 2\text{mA}$$

Ex. 10.9 :

An inductor coil joined to a 12 V battery draws a steady current of 6 A. The coil is

connected to a capacitor and an a.c. source of rms voltage 9 V in series. If the current in the circuit is in phase with the emf, find the rms current.

Soln.

When the current is steady, the inductor simply behaves as a resistor.

Steady current = 6A

Steady emf = 12 V

$$\therefore \text{Resistance of the coil } R = \frac{12\text{V}}{6\text{A}} = 2 \text{ ohm}$$

When the coil is connected to a capacitor and the a.c. source and the current is in phase with the emf $\omega L = \frac{1}{\omega C}$ and the impedance Z of the circuit is simply R.

$$\therefore \text{The r.m.s. current} = \frac{\epsilon_{\text{rms}}}{R} = \frac{9\text{V}}{2\text{ohm}} = 4.5\text{A}$$

Ex. 10.10 :

A series a.c. circuit contains an inductor of $L = 16 \text{ mH}$, a capacitor of $C = 50 \mu\text{F}$ and a resistor of $R = 100\Omega$. If the source voltage is 12 V and the frequency of a.c. is 50 Hz, find the energy dissipated in the circuit in one hour.

Soln.

Given $L = 16 \text{ mH} = 16 \times 10^{-3} \text{ H}$

$C = 50 \mu\text{F} = 50 \times 10^{-6} \text{ F}$

$R = 100\Omega$

$\epsilon_{\text{rms}} = 12 \text{ V}$

$f = 50 \text{ Hz}$

time $t = 1 \text{ hour} = 3600 \text{ s}$

$$\therefore f = 50 \text{ Hz}, T = \frac{1}{f} = \frac{1}{50} \text{ sec} = 0.02 \text{ sec}$$

The duration of energy dissipation = 1 hour which is much larger than T. Hence we may find the energy by finding the average power

P_{av} , given by

$$P_{av} = \varepsilon_{rms} \cdot I_{rms} \cos \phi$$

We have $\cos \phi = \text{power factor} = R/Z$

$$\therefore P_{av} = \varepsilon_{rms} \cdot \frac{\varepsilon_{rms}}{Z} \cdot \frac{R}{Z} = \frac{\varepsilon_{rms}^2}{Z^2} \cdot R$$

$$\Rightarrow P_{av} = \frac{\varepsilon_{rms}^2 R}{R^2 + \left(\frac{1}{\omega C} - \omega L\right)^2}$$

$$\Rightarrow P_{av} = \frac{\varepsilon_{rms}^2 \cdot R}{R^2 + \left(\frac{1}{2\pi f C} - 2\pi f L\right)^2}$$

$$= \frac{(12V)^2 \cdot 100\text{ohm}}{\left[100^2 + \left(\frac{1}{2\pi \times 50 \times 50 \times 10^{-6}} - 2\pi \times 50 \times 16 \times 10^{-3}\right)^2\right] \text{ohm}^2}$$

$$= \frac{12 \times 12 \times 100(\text{volt})^2}{\left[10000 + \left(\frac{10^3}{5\pi} - 1.6\pi\right)^2\right] \text{ohm}}$$

$$= \frac{14400}{10000 + 3488} \text{ watt} = 1.072$$

watt

$$\begin{aligned} \therefore \text{Energy dissipated in 1 hr.} \\ &= 1.072 \text{ J/s} \times 3600 \text{ s} \\ &= 3859.2 \text{ J} = 3.859 \text{ k J.} \end{aligned}$$

SUMMARY

(i) Alternating current (a.c)

It is the current which alters continuously in magnitude and reverses periodically its direction. It is represented by $I = I_0 \sin(\omega t + \phi)$, I_0 , being the peak value of a.c., $\omega = 2\pi/T = 2\pi f = \text{angular frequency of a.c. and } \phi$, the initial phase.

(ii) Average value of a.c. over a one cycle or during one time period is zero.

Average value of a.c. over one half cycle = $\frac{2I_0}{\pi}$ i.e. during the +ve half cycle. The same

over -ve half cycle is $-\frac{2I_0}{\pi}$.

(iii) **R.m.s. or root mean square** value of a.c. is that steady current which produces the same heating effect in the same resistor as that of a.c. during a given time. It is also called the **effective** or the **virtual** value of a.c.

$$I_{rms} = I_{eff} = I_{vir} = I_0 / \sqrt{2}$$

(iv) **A.C.** in a **pure resistor** connected to an alternating source of e.m.f. $\varepsilon = \varepsilon_0 \sin \omega t$ is given

by $I = \frac{\varepsilon_0}{R} \sin \omega t = I_0 \sin \omega t$. Here the **emf** and **current** are in phase with each other.

(v) **A.C.** in **purely inductive circuit** connected to a source of emf given by $\varepsilon = \varepsilon_0 \sin \omega t$ is

expressed as $I = \frac{\varepsilon_0}{\omega L} \sin(\omega t - \pi/2)$

$= I_0 \sin(\omega t - \pi/2)$. Here the **current lags behind the emf** by $\pi/2$ or the emf leads the current by $\pi/2$. ωL is called the inductive reactance of the inductor and has the unit of resistance i.e. ohm. A.c. in a purely capacitive circuit with capacitance C and connected to a source of emf, given by $\varepsilon = \varepsilon_0 \sin \omega t$, is expressed as $I = \varepsilon_0 \omega C \sin(\omega t + \pi/2) = I_0 \sin(\omega t + \pi/2)$. Here the current leads the emf by $\pi/2$ or the emf lags behind the current by $\pi/2$. $1/\omega C$ is called the capacitive reactance of the capacitor and has the unit of resistance too i.e. ohm.

A.c. in a circuit containing a resistance R , an inductance L and a capacitance C in series and connected to a source of emf $\varepsilon = \varepsilon_0 \sin \omega t$ is given by,

$$I = \varepsilon_0 \sin(\omega t + \phi) / \sqrt{[R^2 + (\omega L - 1/\omega C)^2]}$$

$$= (\epsilon_0 / Z) \sin(\omega t + \phi) = I_0 \sin(\omega t + \phi)$$

where Z is called the impedance of the circuit and has the unit ohm. ϕ is called the phase difference between the current and the emf of the circuit and is given by,

$$\phi = \tan^{-1}[(\omega L - 1/\omega C)/R].$$

Average power in an a.c. circuit is given by $P = (1/2)\epsilon_0 I_0 \cos \phi = \epsilon_{rms} I_{rms} \cos \phi$, where $\cos \phi$ is called the power factor of the circuit and is given by,

$$\cos \phi = R / [R^2 + (\omega L - 1/\omega C)^2]^{\frac{1}{2}}$$

For a pure resistive circuit $\phi = 0$ so that $\cos \phi = 1$ and for a purely inductive or purely capacitive circuit $\phi = 90$ so that $\cos \phi = 0$. The component $I_0 \cos \phi$ of a.c. is called the wattful or active component and the component $I_0 \sin \phi$ of a.c., the wattless or idle component. When ϵ and I are in phase, the average power equals $\frac{1}{2}\epsilon_0 I_0$; and when ϵ and I are 90° out of phase, the average power is zero. The impedance of an R-L-C series circuit depends on the frequency f of a.c. The frequency for which the impedance

of the circuit is the minimum is called the resonant frequency of the circuit. The amplitude of current is the maximum at this frequency, the impedance being R and the reactance being zero. Then the resonant frequency is given by $f = 1/2\sqrt{LC}$.

The inductance coil which is used for changing the a.c. in a circuit is called choke coil. In high frequency a.c. circuits choke coil with air core is used while in case of low frequency a.c., choke coil with iron core is used.

Transformer is a device which can be operated with a.c. only and is used to increase the voltage at the cost of current (step up transformer) or to decrease the voltage with increase in current (step down transformer). It is mainly used for long distance transmission of a.c.

A transformer may have, 1. copper loss due to heating of the primary and the secondary coils, 2. iron loss due to eddies formed within the core and due to hysteresis. These losses are avoided to a great extent by using thicker copper wires and laminated soft iron cores.

MODEL QUESTIONS

A. Multiple Choice Type Questions :

1. Which of the following effects is not possible by a.c. ?
 - a. heating effect
 - b. chemical effect
 - c. magnetic effect
 - d. none of the first three
2. A.c. ammeters actually measure
 - a. I_{rms}
 - b. I_0
 - c. I_{ins}
 - d. I^2
3. If R , Z , R_L and R_C stand for resistance, impedance, inductive reactance and capacitive reactance of the a.c. circuit respectively, then power factor of an a.c. circuit is given by
 - a. R/Z
 - b. Z/R
 - c. R/R_L
 - d. R/R_C
4. The emf of an a.c. circuit is given by $e = 60 \sin(53.141 t)$ and the current by $i = (60/10.628) \sin(53.141 t - \pi/2)$. Then the power consumed by the circuit is
 - a. 60 watt
 - b. 60/53.141 watt
 - c. 60/10.628 watt
 - d. zero
5. The peak values of emf and current of an a.c. circuit containing R , L and C are obtained as 200 volt and 20 ampere respectively. The average power of the circuit is
 - a. 2000 watt
 - b. 1414.2 watt
 - c. 1000 watt
 - d. 707.1 watt
6. The phase difference between current and emf in an RLC series circuit at resonance is
 - a. zero
 - b. 90°
 - c. -90°
 - d. 60°
7. A pure capacitor in an a.c. circuit
 - a. stores energy in its electrostatic field
 - b. stores energy in its magnetic field
 - c. does not store energy
 - d. dissipates energy
8. In an a.c. circuit the phase difference between current and emf is 45° . The circuit contains
 - a. a pure inductance
 - b. a pure resistance
 - c. a pure capacitance
 - d. a resistance, an inductance and a capacitance in series.
9. The instantaneous emf of an a.c. circuit is given by $\varepsilon = 4 \sin(100t + \phi)$ volt. If the circuit contains an inductance of 2H, the peak current in the circuit is
 - a. 0.04 A
 - b. 0.02A
 - c. 0.01 A
 - d. 0.005 A
10. When a fluorescent tube is used in an a.c. circuit, it is convenient to use
 - a. a choke in series with the tube.
 - b. a high resistance in series with the tube.
 - c. a low resistance in series with the tube.
 - d. a high resistance in parallel with the tube.
11. An alternating current in a circuit is given by $i = i_1 \sin \omega t + i_2 \cos \omega t$. The rms current in the circuit is given by
 - a. zero
 - b. 90°
 - c. -90°
 - d. 60°

- a. $(i_1 + i_2) / \sqrt{2}$ b. $(i_1 + i_2) / 2$
 c. $\sqrt{(i_1^2 + i_2^2) / 2}$ d. $\sqrt{(i_1^2 + i_2^2)} / \sqrt{2}$
12. The magnetic field energy in an inductor changes from maximum to minimum value in 5 ms when connected to an a.c. source. The frequency of the source is
 a. 20 Hz b. 50 Hz
 c. 200 Hz d. 500 Hz
13. An inductive coil joined to a 6 volt battery draws a steady current of 6 A. The coil is joined to a capacitor and an a.c. source of rms voltage of 6 volt in series. If the current in the circuit is in phase with the emf, the rms current in the circuit is
 a. 12 ampere b. 6 ampere
 c. $3\sqrt{2}$ ampere d. 3 ampere
14. An inductor coil having some resistance is connected to an a.c. source. The physical quantity having zero average value over a cycle is
 a. induced emf in the inductor
 b. joule heat in the inductor
 c. magnetic energy in the inductor
 d. total energy in the circuit
15. The metal / alloy that is more suitable for making cores of transformers is
 a. steel b. soft iron
 c. copper d. brass
16. A transformer has 20 turns of primary and 100 turns of secondary. If the primary is connected to a 220 volt d.c. supply, the voltage across the secondary will be
 a. 1100 volt b. 220 volt
 c. 10 volt d. zero volt
17. The voltage applied across the primary of a transformer is 220 volt. If the

resistance of the primary is 20 ohm and efficiency of the transformer is 90%, the output power is

- a. 2420 watt b. 2178 watt
 c. 11 watt d. 9.9 watt
18. The peak value of an alternating current is 5 amp., and its frequency is 60 Hz. Starting from zero, the time after which the current reaches its peak value is
 a. 60 sec. b. 12 sec.
 c. 1/12 sec. d. 1/240 sec.

B. Very Short Answer Type :

- What is the reactance of a capacitor connected to a steady d.c. circuit ?
- Can the peak voltage across an inductor be greater than the peak voltage of the source in an LCR circuit ?
- Is energy produced when a transformer steps up the emf ?
- Define what is a.c.
- Write the relation between the peak value and the rms value of a.c.
- What is the mean value of a.c. over a full cycle ?
- Can a.c. be used for electrolysis ?
- What is the amplitude and phase of a.c. in the equation $I = 3 \sin (120 \pi t - \pi/3)$?
- Define rms value of a.c.
- Define power factor.
- Mention the factors on which the reactance of an inductor depends.
- Mention the factors on which the reactance of a capacitor depends.
- Mention the factors on which the impedance of an a.c. circuit depends.
- Define impedance of an a.c. circuit.
- Which is more dangerous, a.c. or d.c. ?

16. How much reactance is provided by a capacitor in a steady d.c. circuit ?
17. How does an inductor behave when connected in a d.c. circuit ?
18. What is meant by wattless component of a.c. ?
19. Mention the function of a transformer.
20. Write down the names of the losses obtained in a transformer.
21. Mention the cause of copper loss in a transformer.
22. Write down the phase difference occurring between current and emf in a purely inductive a.c. circuit.
23. What type of transformer is used at the generating station of a.c. to transmit power ?
24. Is energy spent for sending a.c. through a purely inductive circuit ? [CHSE, 1986 S]
25. In what kind of a.c. circuit current lags behind the emf ? [CHSE, 1995 S]
26. What is virtual ampere ? [CHSE, 1993 A]
27. What is the rms value if the peak value of alternating current is 5 ampere ?
[CHSE 1995 S]
28. In what kind of a.c. circuit, the current lags behind the voltage ? [CHSE 1995 S]
29. What is the phase difference between current and emf in a purely capacitive circuit ? [CHSE, 1995 A]
30. Can power factor of an a.c. circuit be equal to one ?
31. What is the phase difference between the voltage across the inductance and a capacitor in an a.c. circuit.
[CBSE, 1999]
32. What is the phase difference between voltage and current in a LCR series circuit at resonance ? [CBSE 1997, 98, 99]
33. The instantaneous voltage from an ac source is given by $E = 300 \sin 314 t$; what is the rms voltage of the source ?
[CBSE AI 2000]
34. What is the average value of ac voltage $V = V_0 \sin \omega t$. [CBSE Sample Paper]
35. An electrical element x when connected to an alternating voltage source, has a current through it leading the voltage by $\pi/2$ rad. Identify x and write an expression for its reactance.
[CBSE Sample Paper]
- C. Short Answer Type :**
1. Explain what is rms value of a.c. ?
 2. Differentiate between average value and rms value of a.c. over a cycle.
 3. Write down an equation representing alternating current and explain the symbols used in it.
 4. Show that average value of a.c. over a cycle is zero.
 5. Explain the meaning of wattless component of a.c.
 6. Why is a choke coil used in an a.c. circuit but not a resistor ?
 7. Explain what are iron and copper losses in a transformer.
 8. Differentiate between step up and step down transformers.
 9. Why is a.c. used widely though it is more dangerous than d.c. ?
 10. In considering the voltage in an a.c. circuit required to puncture a capacitor should one be concerned with the effective, maximum or average values ? Explain.
 11. An a.c. circuit contains a variable capacitor in series with a fixed resistor. Plot any curve as : capacitance is varied from zero to a very large value.
 12. A choke coil, placed in series with an electric lamp in an a.c. circuit, causes the lamp to become dimmed. Explain.

13. A choke coil and a variable capacitor are placed in series with an electric lamp in an a.c. circuit. The capacitor is adjusted to make the lamp glow brilliantly. Explain how it is possible ?
 14. Explain what is apparent power in an a.c. circuit.
 15. Explain the meanings of wattful and wattless components of a.c.
 16. Which physical quantity is expressed in kilovolt-ampere in connection with a.c. ?
 17. Find an expression for the average power expended in a resistor in a quarter cycle of a.c.
 18. Graphically show the variation of inductive reactance and capacitive reactance with frequency of a.c.
 19. Mention the variation of resistance, capacitive reactance and inductive reactance with the frequency of a.c.
 20. Distinguish between resistance and reactance in an a.c. circuit.
 21. Write the expression for the impedance of an LCR circuit and hence show the condition under which its impedance equals its resistance.
 22. Explain which is more dangerous for human body, 220 volt a.c. or 220 volt d.c.
 23. Explain the meaning of lagging current and leading current in case of a.c.
 24. Explain the necessity of transformer in long range transmission of power.
[CHSE, 87 S]
 25. A coil having inductance of 1 henry is connected to an a.c. source of frequency 50 hertz. What would be the inductive reactance of the coil ? [CHSE, 1989 A]
 26. A capacitor of capacity $5 \mu\text{F}$ is connected to an a.c. source of frequency 1000 Hz. What is the capacitive reactance of the circuit ? [CHSE, 1991 A]
 27. An a.c. circuit contains an inductance of 10 henry. What is the reactance of the circuit ? (frequency of source is 50 Hz).
[CHSE, 1991 S]
 28. Why is long distance transmission of electric power done at high voltage and low current ? [CHSE, 1993 A]
 29. The primary and secondary of a transformer have 200 and 600 turns respectively. If the input voltage is 210 volts, calculate the output voltage.
[CHSE, 1994 A]
 30. The primary and secondary of a transformer have 500 and 2000 turns respectively. If the input current is 16 ampere, calculate the output current.
[CHSE, 1995 A]
 31. Prove mathematically that the average power over a complete cycle of alternating current through an ideal inductor is zero. [CBSE 1997, 99]
 32. An electric lamp connected in series with a capacitor and an ac source is glowing with certain brightness. How does the brightness of the lamp change on reducing the (i) capacitance and (ii) frequency ? [CBSE 1997, 99]
 33. Prove that an ideal capacitor in an a.c. circuit does not dissipate power.
[CBSE 2008]
 34. When a capacitor is connected in series LR circuit, the alternating current flowing in the circuit increases. Explain why ?
[CBSE 1999]
- D. Long Answer Type :**
1. Differentiate between direct current and alternating current. Obtain an expression for the rms value of the latter i.e. a.c. over cycle. What is the difficulty in using the average value of a.c. ?
 2. Write down the equation that represents a sinusoidal a.c. Obtain expressions for its mean value and rms value over a cycle

- in terms of the peak current. Why is a.c. considered to be more dangerous than d.c. ?
- Derive the expression for current in a purely inductive a.c. circuit. Why is it called wattless current ? Draw the phasor diagram for voltage and current of the circuit. (CHSE, 1994 A)
 - An a.c. circuit contains a resistance and an inductance in series. Draw the circuit diagram and calculate the current in the circuit. What is the phase of the current in the inductance with respect to applied emf ? (CHSE, 1995 A)
 - What is alternating current ? Prove the following for a.c.
(i) $I_{\text{effective}} = I_0/\sqrt{2}$, (ii) $I_{\text{average}} = 2I_0/\pi$ for positive half cycle. I_0 = Peak value of a.c. and the other symbols have usual meaning. (CHSE, 1996 A)
 - Discuss principle, theory and construction of a transformer. What are the various types of losses in it ? Mention its two main uses.
 - Obtain an expression for the average power in an a.c. circuit containing a resistance. Show that it is equal to the product of the virtual values of emf and current of the circuit.
 - The emf and current of an a.c. circuit containing L, C and R are given by
 $\varepsilon = \varepsilon_0 \sin \omega t$ and $I = I_0 \sin(\omega t - \phi)$.
Show that the average power of the circuit is $P_{\text{av}} = \varepsilon_v I_v \cos \phi$, where ε_v and I_v stand for virtual emf and virtual current respectively.
 - Show that the current leads the applied voltage by 90° in a purely capacitive a.c. circuit. Find the impedance of the circuit and discuss its variation with frequency of the a.c. source. If $f = 50 \text{ Hz.}$, $C = 2 \mu\text{F}$, what is the value of the same ?
 - Deduce an expression for the power of an a.c. circuit containing a resistance and an inductance. Explain what is power factor. What will be the power factor if the resistance of the circuit is zero and why ?
- E. Numerical Exercises :**
- Alternating current in a circuit is given by $I = 50 \sin 400 \pi t$. Find the frequency and the rms value of the current.
 - A circuit has an inductance of $1/2\pi$ henry and a resistance of 500 ohms. If an a.c. of frequency 50 c.p.s. is applied to it, find reactance and the impedance of the circuit.
 - Calculate the capacitance of a capacitor to run a 250 V, 100 W lamp connected in series with an a.c. mains of 220 volt having frequency 50 hertz.
 - A 60 Hz. a.c. circuit has a voltage of 120 volts and a current of 6 amp. (effective values). Find the maximum values of these quantities. What is the instantaneous value of the voltage $1/720$ sec. after the voltage has zero value ?
 - A coil which takes 10 amps from 20 volt d.c. circuit, takes 3 amps. from a 120 volt, 60 cycle line. Find the resistance, inductive reactance and inductance of the coil.
 - A coil takes 3 amps and 108 watts from a 120 volt, 60 cycle line. Find what are its resistance and inductance.
 - The resistance in a certain 220 volt 60 cycle a.c. series circuit is 82.4 ohms and the capacitive reactance is 60 ohms. Find the total impedance. Calculate the current in the circuit and the capacitance.
 - At which frequency of a.c. will the inductive reactance of a 20 mh inductor be equal to the capacitive reactance of a $20 \mu\text{F}$ capacitor ? Calculate.

9. The current through a coil is 2A when connected to a 8V d.c. supply. When the same coil is connected to a 15V a.c. supply at 50 Hz, the current is 3A. Find the resistance, impedance, inductive reactance, inductance and power factor of the coil.
10. The input and output impedances of a transformer, which delivers 20W of power, are 1000 ohm and 8 ohm respectively. Calculate its turn ratio and the current and potential difference in the primary and the secondary.
11. The voltmeter reading across a 60 Hz source of alternating emf is 220V. Write the equation for the instantaneous emf of the source. If it is connected across a 50Ω resistor find the peak current in the circuit.
12. A single circuit element is connected across a source of alternating emf given by $V = 100V \sin 100\pi t$. Determine the circuit element if the current in the circuit is written as $I = 20 A \sin (100\pi t + \pi/2)$.
13. A 40 V, 500-cycle a.c. source is connected to a series circuit containing a 5 ohm resistor, a capacitive reactance of 4 ohm and a coil which has a resistance of 1.25 ohm and an inductive reactance of 12 ohm. Calculate the power and the power factor.
14. If the electric current in a circuit is given by $I = I_0 (t/\tau)$ for some time, find the rms current for the period from $t = 0$ to $t = \tau$.
15. A coil having a resistance of 50 ohm and an inductance of 0.5 henry is connected to an a.c. source of $V_{rms} = 220$ volt and $f = 50$ cycle/sec. Find the peak value of current.
16. A series combination of $C = 100 \mu F$, $R = 50\Omega$ and $L = 0.5 H$ is connected to a 110 V, 50 Hz a.c. source. Calculate the peak current, power and power factor of the circuit.
17. An inductor of inductance 100 mH is connected in series with a resistance, a variable capacitance and an a.c. source of frequency 2000 Hz. Find the value of the capacitance so that maximum current may be drawn into the circuit.
18. A series a.c. circuit contains an inductance of 40 mH, capacitance of $100 \mu F$, resistance of 50Ω and an a.c. source of 12 V, 50 Hz. Calculate the energy dissipated in the circuit in one hour.
19. A lamp which can carry a current of 10A at 15V, is connected to an alternating source of emf 220V. If the frequency of the source is 50 c.p.s., find the inductance of the choke coil required to lit the lamp.
20. Find the value of inductance which should be connected in series with a capacitance of 5 microfarad and a resistance of 10 ohms, to an a.c. source of 50 c.p.s., so that the power factor of the circuit is unity.
21. A current is made of a 3 amp d.c. component and an a.c. component given by $I = 4 \sin \omega t$ Amp. Find an expression for the resultant current and calculate its effective value. [Hint: $I = I_{dc} + I_{ac}$. Find the square of I and hence obtain I_{rms}].
22. When 100V d.c. is applied across a coil, a current of 1A is observed through it. When 100V a.c. of 50 Hz is applied to the same coil only 0.5 A is observed. Calculate the resistance, impedance and inductance of the coil. What would be the phase lag between this current and the applied emf.
23. A 100 volt a.c. source of frequency 500 Hz is connected to a series LCR circuit with $L = 8.1 mH$, $C = 12.5 \mu F$ and $R = 10\Omega$. Find the potential difference across the resistance. [Hint : Obtain values of $R_L = \omega L$ and $R_C = 1/\omega C$ and see that $R_C = R_L$. Hence $I = V/R$ i.e. the resonance condition.]

24. A radio can tune over the frequency range of a portion of medium wave broadcast band between 800 kilohertz and 1200 kilohertz. If the LC circuit has an effective inductance of $200 \mu\text{H}$, find the range of the variable capacitor required for the purpose. [Hint : Find $f = 1/2\pi \sqrt{LC}$; hence $C = 1/4\pi^2 f^2 L$. Determine C for $f = 800 \text{ kHz}$ and 1200 kHz .]
25. A bulb of resistance 10Ω , connected to an inductor of inductance L, is in series with an ac source marked 100 V, 50 Hz. If the phase angle between the voltage and current is $\pi/4$ radian, calculate the value of L. [CBSE 2001]
26. A $25.0 \mu\text{F}$ capacitor, a 0.10 H inductor and a 25.0Ω resistor are connected in series with an ac source of emf given by $E = 310 \sin 314 t$. What is the frequency of emf and reactance of the circuit ? [CBSE 1995]
27. In an LR series circuit, the potential difference across the inductor L and resistor R are 200 V and 150 V respectively and the rms value of current is 5 A. Calculate (i) the impedance of the circuit and (ii) the phase angle between the voltage and current. [CBSE 2004]
28. An a.c source of frequency 50 Hz is connected to a 50 mH inductor and a bulb. The bulb glows with some brightness. Calculate the capacitance of the capacitor to be connected in series with the circuit, so that the bulb glows with maximum brightness. [CBSE 2000]
29. When an inductor L and a resistor R in series are connected across a 12 V, 50 Hz supply, a current of 0.5 A flows in the circuit. The current differs in phase from applied voltage by $\pi/3$ radian. Calculate the value of R. [CBSE 2008]
30. In an ideal transformer, the number of turns in the primary and secondary are 200 and 1000 respectively. If the power input to the primary is 10 kW at 200 V, calculate (i) output voltage and (ii) current in primary. [CBSE 2001]
- F. Answer as directed**
- Ohm's law is applicable only to _____ circuit in A.C.
 - How will you connect a choke, when a fluorescent tube is used in A.C. circuit ? (Series / Parallel with the tube).
 - One complete set of positive and negative values of alternating current or emf is called _____.
 - What is the basis of hot wire instruments ?
 - What is used as core in a radio frequency choke ?
 - At low frequency a condenser offers high impedance. (Yes/No)
 - In a series L-C-R circuit what is the value of total impedance at resonance ?
 - Why a choke coil is preferred to a rheostat in an a.c. circuit ?
 - When power is drawn from the secondary circuit of a transformer, will the dynamic resistance increase/decrease/remains constant.
- G. Correct the following sentences :**
- The rms value of a.c is $I_0/2$.
 - The average value of a.c is $I_0/\sqrt{2}$.
 - The impedance Z of a series L-C-R a.c circuit is $Z = [R^2 + (L - 1/C)^2]^{1/2}$
 - At high frequency a condenser offers high impedance.
 - The resonance frequency f of a series L-C-R a.c circuit is given as $f = 2\pi(1/LC)^{1/2}$.
 - D.c is more dangerous than a.c.
 - In L-R a.c circuit current leads emf.

ANSWERS

A. Multiple Choice Type Questions :

1. (b) 2. (a) 3. (a) 4. (d) 5. (c) 6. (a) 7. (a) 8. (d)
 9. (b) 10. (a) 11. (c) 12. (b) 13. (b) 14. (a) 15. (b) 16. (d)
 17. (b) 18. (d)

D. Numerical Exercises :

1. 200 Hz, $25\sqrt{2}$ A
 2. 50Ω , 502.5Ω
 3. $6.9\ \mu\text{F}$
 4. 169.7 V, 8.5 A, 84.85 V
 5. 2Ω , 20Ω , 0.053 H
 6. 12Ω , 40Ω
 7. 102Ω , 2.2A, $44.2\ \mu\text{F}$
 8. 252 Hz
 9. 4Ω , 5Ω , 3Ω , 9.55 mH, 0.8
 10. 1 : 35.4, $V_p = 100\sqrt{2}$ V, $V_s = 4\sqrt{10}$ V
 11. $\varepsilon = 220\sqrt{2}\sin 120\pi t$, 6.22A
 12. $C = 0.637\ \text{mF}$
 13. 118.6 watt \rightarrow 70.43 watt
0.6 \rightarrow 113.6
 14. $I_0 / \sqrt{3}$ A
 15. 1.89 A
 16. 1.15 A, 89.45 watt, 0.37
 17. 63.3 nF
 18. 9676.8 \rightarrow 9028.45 joule
 19. 220 mH
 20. 2.03 H
 21. 4.12 A
 22. $R = 100\Omega$, $L = 0.55\ \text{H}$, $Z = 172.8\Omega$, $\phi = 60^\circ$
 23. 100 V
 24. $C_{\min} = 88\ \text{pF}$, $C_{\max} = 198\ \text{pF}$
- E. 25. 0.0318 H, 26. 50 Hz, 31.4Ω 27. 50Ω , 53° 28. 2.0×10^{-4}
 29. 12Ω 30. 1000V, 50 A
- F. (1) Resistive (2) Series with the tube (3) Cycle (4) Heating effect of current (5) Air (6) Yes
 (7) R (8) It consumes almost zero power (9) Increase.

11

Reflection and Spherical mirror

11.1 Light Preliminaries :

There are several forms or types of energy, like electricity, heat, sound, magnetic, mechanical etc. This list also includes light energy.

Light is a form of energy, which itself is invisible; but when it falls on an object, that object becomes visible to us through our sense organ - the eye. Thus light is the external cause of sensation of sight.

While dealing with light we often come across the following terms:

Ray of light is a straight line which marks not only the transfer of light energy but indicates its direction also. The direction is indicated by an arrow.

Pencil of light is a small bunch of rays of light.

Beam of light is an appreciably large bundle of rays. If rays in a beam start and progress away from a point, then these rays are called divergent. But if the rays proceed towards a point, then it is a case of convergent beam.

In a parallel beam, the light rays are parallel to each other.

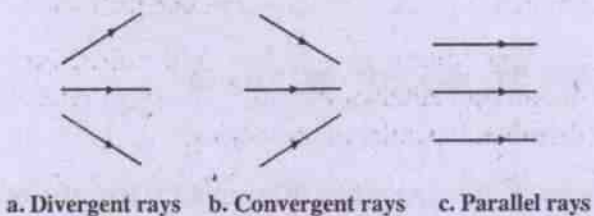

Fig. 11.1

Rectilinear Propagation of light :

When light passes through a particular medium (say, air, water, glass etc.) it does not change its direction of motion; i.e., the light-path remains unchanged. This phenomenon is known as the rectilinear propagation of light. However, when it meets another medium in its path, the following effects may occur:

(1) Reflection :

A part of the incident light is turned back; moves from the surface of the second medium to the first medium. This is known as reflection.

Reflection can be of two types : (i) Regular type, (ii) Irregular (or, diffused) type.

(2) Absorption :

A portion of the light, incident on the second medium, may be absorbed by the latter, leading to interconversion of light into heat energy etc.

(3) Refraction :

The remaining part may pass through the second medium, obeying the laws of refraction.

Thus : Incident light = Reflected (Regular and irregular) light + Absorbed light + Refracted (transmitted) light.

Regular reflection takes place, when light falls on a smooth surface like mirror, polished metal surface etc.

Regular reflection is subject to the following two laws :

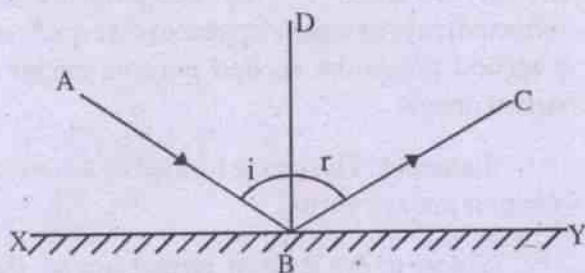

Regular Reflection

Fig. 11.2

- XY = Plane mirror
- AB = Incident ray
- B = Point of incidence
- BC = Reflected ray
- BD = Normal to the mirror at the point of incidence

$\angle ABD = \text{Angle of incidence} = i$

$\angle DBC = \text{Angel of reflection} = r$

(1) The incident ray, reflected ray and normal at the point of incidence lie in one plane. (AB, BC and BD lie in the plane of paper in this case).

(2) Angle of incidence is equal to the angle of reflection. ($\angle ABD = \angle DBC$, i.e. $i = r$)

11.2 Spherical Mirror:

A part of a regular, reflecting, hollow sphere can be used as a spherical mirror. Spherical mirror is of two types :

- (1) Concave mirror
- (2) Convex mirror

Concave mirror :

In this type, reflection occurs on the hollow side. When we hold such a mirror (APB) facing us, its middle point P will be at the greatest distance when compared with its

other points.

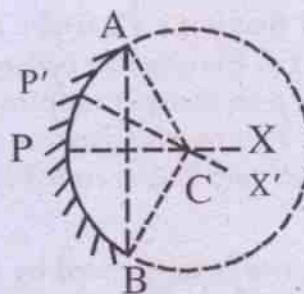

Concave mirror

Fig. 11.3

- P = Pole (or, vertex)
- C = Center of curvature
- PC = Radius of curvature (= r)
- PX = Principal axis
- P'X' = Secondary axis

Some definitions, relating to spherical mirrors, are given below :

Pole: Pole of a mirror is defined as the middle point of the reflecting surface.

Centre of curvature : It is the centre of the sphere, out of which the mirror is formed.

Radius of curvature : It is the radius of the sphere, of which the mirror forms a part.

Axis : Any straight line, passing through the centre of curvature and any point of the spherical mirror forms the axis of the mirror.

Axis may be of two types.

- (1) Principal axis
- (2) Secondary axis

Principal axis is a direction which contains the center of curvature and the pole.

Secondary axis is any other direction containing center of curvature and any point, other than the pole, of the mirror.

Any axis, Principal or Secondary, is normal to the mirror.

Principal Section : Consider a spherical mirror. Let us imagine that a plane is passing through the principal axis and also intersecting the mirror. Then the cross-section of the mirror is a circular arc. This is called the principal section.

A mirror is represented by its principal section.

Aperture : The length between the two extreme points of the principal section is known as the aperture.

Angular aperture : This is the angle subtended by the diameter (aperture) at the center of curvature of the mirror.

In Fig. 11.3,

$$\begin{aligned} \text{Angular aperture} &= \angle ACB \\ &= \frac{\text{Arc APB}}{\text{Radius AC}} \end{aligned}$$

Normally we consider spherical mirrors of small angular aperture (say, less than 10° of arc).

Optical image :

If the direction of rays, starting from a point source, changes either due to reflection (or refraction), so that the reflected (or refracted) rays either actually converge to, or appear to diverge from, a second point, then the second point is called the optical image of the first point source.

Optical images are of two types :

- (i) Real image
- (ii) Virtual image

(i) **Real image:** When the reflected (or refracted) rays of a point actually converge to (i.e., intersect) at a second point, the second point is called a real image.

Hence the image formed by a plane mirror cannot be a real image.

(ii) **Virtual image :** When the reflected (or refracted) rays of a point appear to diverge from a second point, the second point is called a virtual image.

Example : The image formed by a convex mirror is always virtual.

Since, in the case of virtual image, the reflected (or, refracted) rays don't actually intersect, the image is merely an imaginary intersection point and hence cannot be held on a screen or photographed.

As mentioned above, the optical image is formed due to reflection or refraction. As such, the image formed by a pin-hole camera cannot be called an optical image, since it is not formed by reflection or refraction, but by rectilinear propagation of light.

Principal focus and focal length :

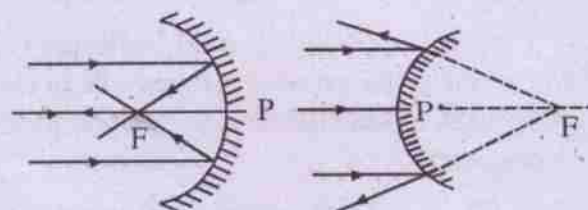

Focus (a) Concave mirror

(b) Convex mirror

Fig. 11.4

Concave mirror :

Convex mirror :

F = Focus (Real)

F = Focus (Virtual)

PF = Focal Length

PF = Focal length

Fig. 11.4(a)

Fig. 11.4(b)

Let a pencil of rays, parallel to the principal axis, be incident on a spherical mirror.

(a) In case of concave mirror, all the rays, after reflection, will converge to a point (F) on the principal axis. This is real, since all the reflected rays actually intersect at F.

(b) In case of convex mirror, the rays, after reflection, appear to diverge from a single point on the principal axis. This point (F) is known as the focus, but this is virtual, since the reflected rays do not actually intersect.

In both the cases, the distance between the pole and the focus is known as the focal length.

Focal Plane : Any plane, which is vertical to the principal axis and passes through the focus, is known as the focal plane.

11.3 Procedure for object-image Ray diagram : Spherical mirrors

(i) Point object :

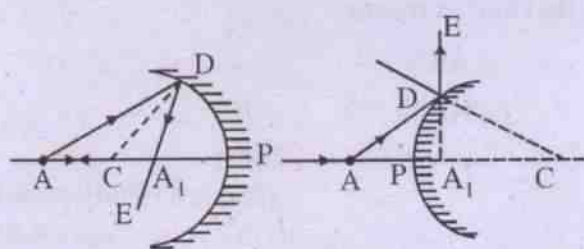

(a) Concave mirror (b) Convex mirror

Fig. 11.5 Image-formation-point object

Let a point-object A be on the principal axis. A ray, starting from A and passing through C, after reflection at the mirror, will retrace its path (AP ↔ PA) due to normal incidence, along the Principal axis.

Take now another ray, AD which, on reflection, will move along DE. The reflected ray DE will intersect (in case of concave mirror) the Principal axis at A₁ or appear to intersect (in case of convex mirror) at A₁ on the principal axis.

Thus A₁ is image [Real - in Fig. 11.5 (a)] and [Virtual - in Fig. 11.5 (b)] of the point object A.

(ii) Extended object :

Consider an extended object AB, placed normal to the Principal axis of the mirror.

Take two rays starting from the top of the object A - one ray through C and another ray passing parallel to the principal axis and then find out the intersection of their reflected rays. Then the intersection of the reflected rays gives the image.

(a) Concave mirror :

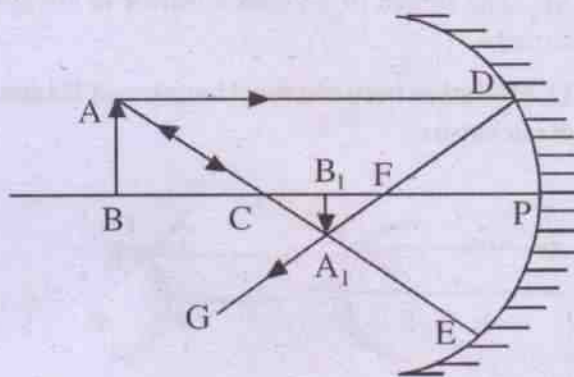

Image formulation (Extended object) Concave mirror

Fig. 11.6

The ray passing through C retraces its path along ECA on reflection. The other ray AD, parallel to the principal axis, is reflected along DFG, so that the intersection of ECA and DFG gives the image at A₁. Drop a normal from A₁ on the principal axis, A₁B₁.

Thus A₁B₁ is the image of AB. In this case this is real.

(b) Convex mirror :

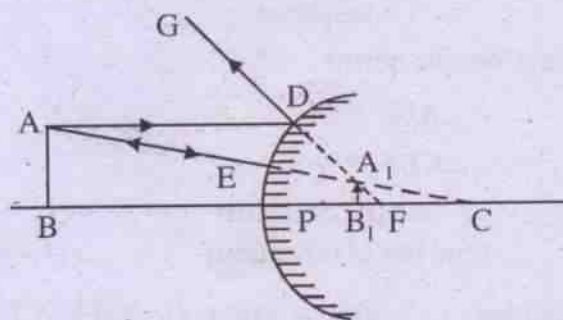

Tracing of image (Extended object) Convex mirror

Fig. 11.7

The ray, proceeding towards C, retraces its path along CEA after reflection. The other ray AD parallel to principal axis is reflected along DG. The intersection of the two reflected rays EA and DG is obtained by producing them backwards. The intersection point is at A_1B_1 behind the mirror. Thus A_1B_1 is the image of AB. The image of a convex mirror is always virtual.

11.4 Relation between focal length and Radius of curvature

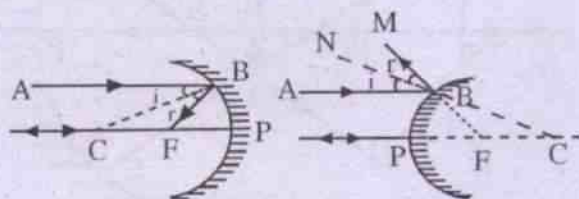

(a) Concave mirror (b) Convex mirror

Fig. 11.8 Relation between r and f

Let the object be at infinity (∞). The rays coming out of it are parallel. Consider one of its rays AB, moving parallel to the Principal axis. After reflection it intersects at F (concave mirror) and appears to intersect at F (convex mirror). Thus F is the image formed on the Principal axis of the distant object (located at infinity).

In the above figure,

B = point of incidence

C = centre of curvature

CB = Normal at the point of incidence.

(a) Concave mirror :

$$\angle ABC = i$$

$$\angle CBF = r$$

$$\therefore \angle ABC = \angle CBF$$

$$\text{(2nd law of reflection) } \dots(11.4.1)$$

$$\text{Further } \angle ABC = \angle BCF \quad (\because AB \parallel CF) \dots(11.4.2)$$

Comparing the above two equations,

$$\angle CBF = \angle BCF$$

So that the triangle CBF is isosceles.

$$\therefore BF = CF \dots(11.4.3)$$

Assume that the mirror has small aperture and the rays are very near to the principal axis, so that we can replace the point B by point P, without much error.

Hence eqn. (11.4.3) gives

$$PF = CF \dots(11.4.4)$$

Now $r = CP$

$$= PF + FC$$

$$= 2PF \quad \text{(by 11.4.4)}$$

$$= 2f$$

$$\text{Thus } r = 2f \dots(11.4.5)$$

(b) Convex mirror :

$$\angle ABN = i$$

$$\angle NBM = r$$

$$\therefore \angle ABN = \angle NBM$$

(2nd law of reflection)

$$\dots(11.4.6)$$

$$\text{Further } \angle NBA = \angle BCP \quad (\because AB \parallel CP) \dots(11.4.7)$$

Comparing the above two equations

$$\angle NBM = \angle BCP \dots(11.4.8)$$

$$\text{But } \angle NBM = \angle CBF \quad \dots(11.4.9) \text{ (opposite angles)}$$

Comparing eqns. 11.4(8 & 9), we have

$$\angle BCP = \angle CBF$$

So that CBF is an isosceles triangle.

$$\therefore BF = CF \dots(11.4.10)$$

Assuming the mirror to be of small aperture and considering the rays very close to principal axis, we replace B by P in eqn. (11.4.10), so that

$$CF = PF \dots(11.4.11)$$

Now $r = CP$

$$= CF + FP$$

$$= 2PF \quad \text{(by eqn. 11.4.11)}$$

$$= 2f$$

$$\text{Thus } r = 2f \dots(11.4.12)$$

Eqns 11.4 (5 & 12) show that there is a general formula for spherical mirrors, which can be written as

$$r = 2 f \quad \dots(11.4.13)$$

11.5 Sign Convention : Spherical mirrors

The International commission of optics has recommended a system of sign convention, known as New Cartesian (N.C.) for measuring distances such as focal length, radius of curvature, object distance, image distance etc for both lenses and mirrors.

The rules are :

- (1) All the ray-diagrams will be drawn with light travelling from left to right.
- (2) The pole and the optic center will be taken as the origin (of the co-ordinate system) for measurement in case of mirrors and lenses respectively.
- (3) The Principal axis will be taken along the X-axis of the co-ordinate system.
- (4) Distances measured towards left of the origin are negative and towards the right are positive.
- (5) Transverse measurements, i.e., distance above X-axis are positive and downwards are negative.

Graphically :

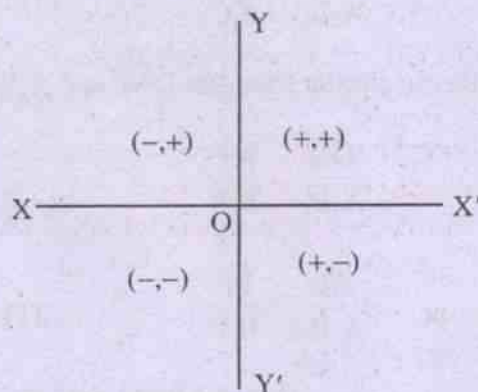

Fig. 11.9 New cartesian sign convention

Note regarding sign convention :

Measurement	
Horizontal	Vertical
x	y

Example: For 2nd Quadrant, (i.e., Yox)

$$x = -ve$$

$$y = +ve$$

or, (-, +)

11.6 u-v relation for spherical mirrors :

(a) Concave mirror

Case 1 (Real image) :

When the object is placed beyond F, real image is formed.

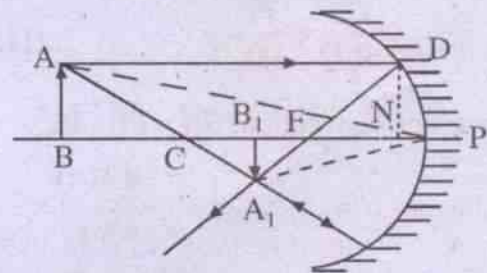

(Concave mirror - Real image)

Fig. 11.10

AB = Upright object, placed normal to principal axis.

PB = Distance between pole and object = object distance = u (say)

A₁B₁ = Image (real) of AB

PB₁ = Distance between pole and image = Image distance = v (say)

In the similar triangles ABC and A₁B₁C₁

$$\frac{AB}{A_1B_1} = \frac{CB}{B_1C} \quad \dots(11.6.1)$$

Drop a normal DN on the Principal axis from the point of incidence D. Now in the similar triangles DNF and A₁B₁F.

$$\frac{DN}{A_1B_1} = \frac{NF}{FB_1}$$

or,
$$\frac{AB}{A_1B_1} = \frac{NF}{FB_1} \quad (\because \text{ABND is a rectangle}) \quad (11.6.2)$$

Equating eqns. 11.6. (1 & 2)

$$\frac{CB}{B_1C} = \frac{NF}{FB_1} \quad \dots(11.6.3)$$

Since we are considering mirrors with small aperture and incident rays very close to the Principal axis, we can replace N by P in eqn. 11.6.3 as an approximation.

$$\text{Thus } \frac{CB}{B_1C} = \frac{PF}{FB_1} \quad \dots(11.6.4)$$

Using sign convention, $CB = PB - PC$

$$= -u - (-r)$$

$$= -u + r$$

$$= -u + 2f$$

$$B_1C = PC - PB_1$$

$$= -r - (-v)$$

$$= -r + v$$

$$= -2f + v$$

$$PF = -f$$

$$FB_1 = PB_1 - PF$$

$$= -v - (-f)$$

$$= -v + f$$

Substituting these values in 11.6.4, we have

$$\frac{-u + 2f}{-2f + v} = \frac{-f}{-v + f}$$

Cross-multiplying and simplifying

$$uv = fv + uf$$

Dividing throughout by uvf :

$$\frac{1}{f} = \frac{1}{u} + \frac{1}{v} \quad \dots(11.6.5)$$

Concave mirror :

Case 2 (Virtual image):

When the object is placed between P and F, virtual image is produced.

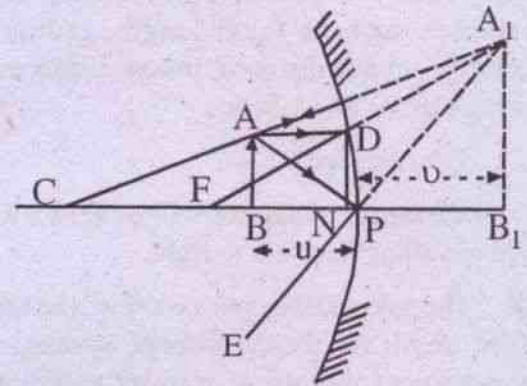

Concave mirror - Virtual image

Fig. 11.11

$AB = \text{object}$

$A_1B_1 = \text{image (virtual)}$

Drop a normal DN from D on the Principal axis.

In the similar triangles ABC and A_1B_1C

$$\frac{AB}{A_1B_1} = \frac{BC}{B_1C} \quad \dots(11.6.6)$$

Further in similar triangles DNF and A_1B_1F :

$$\frac{DN}{A_1B_1} = \frac{NF}{B_1F}$$

$$\text{or } \frac{AB}{A_1B_1} = \frac{PF}{B_1F} \quad \dots(11.6.7)$$

(Since $ABND$ is a rectangle, $DN = AB$. Further N being close to P , $NF \approx PF$)

Comparing eqns. 11.6 (6 & 7), we get

$$\frac{BC}{B_1C} = \frac{PF}{B_1F} \quad \dots(11.6.8)$$

Using sign convention,

$$\begin{aligned} BC &= PC - PB \\ &= -2f - (-u) \\ &= -2f + u \end{aligned}$$

$$\begin{aligned} B_1C &= PC + PB_1 \\ &= -2f + v \end{aligned}$$

$$PF = -f$$

$$\begin{aligned} B_1F &= PF + PB_1 \\ &= -f + (+v) \\ &= -f + v \end{aligned}$$

Substituting these values in eqn. (11.6.8)

$$\frac{-2f + u}{-2f + v} = \frac{-f}{-f + v}$$

Cross-multiplying and simplifying

$$uv = uf + vf$$

Dividing throughout by uvf :

$$\frac{1}{f} = \frac{1}{u} + \frac{1}{v} \quad \dots(11.6.9)$$

(b) *Convex mirror* :

A convex mirror always produces a virtual image, irrespective of the position of the object, placed in front of the mirror.

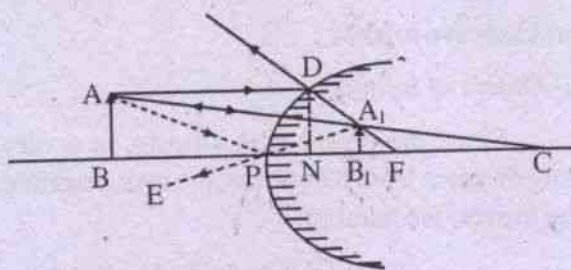

Convex mirror - Virtual image

Fig. 11.12

AB is the object and A_1B_1 is its image. DN is constructed as a normal from D on the principal axis.

In the similar triangles ABC & A_1B_1C

$$\frac{AB}{A_1B_1} = \frac{BC}{B_1C} \quad \dots(11.6.10)$$

In the similar triangles DNF and A_1B_1F

$$\frac{DN}{A_1B_1} = \frac{NF}{B_1F}$$

$$\text{or } \frac{AB}{A_1B_1} = \frac{PF}{B_1F} \quad \dots(11.6.11)$$

Since ABND is a rectangle, $DN = AB$ and N, being close to P, $NF \approx PF$

Comparing eqns. 11.6 (10 & 11), we have

$$\frac{BC}{B_1C} = \frac{PF}{B_1F} \quad \dots(11.6.12)$$

Applying sign convention :

$$\begin{aligned} BC &= PB + PC \\ &= -u + (+2f) \\ &= -u + 2f \end{aligned}$$

$$\begin{aligned} B_1C &= PC - PB_1 \\ &= +2f - (+v) \\ &= 2f - v \end{aligned}$$

$$PF = +f$$

$$\begin{aligned} B_1F &= PF - PB_1 \\ &= +f - (+v) \\ &= f - v \end{aligned}$$

Substituting these values in (11.6.12)

$$\frac{-u + 2f}{2f - v} = \frac{f}{f - v}$$

Cross multiplying and simplifying

$$uv = vf + uf$$

Dividing throughout by uvf :

$$\frac{1}{f} = \frac{1}{u} + \frac{1}{v} \quad \dots(11.6.13)$$

On the basis of eqns. 11.6 (5, 9 & 13), we obtain the general formula for spherical mirrors as :

$$\frac{2}{r} = \frac{1}{f} = \frac{1}{u} + \frac{1}{v} \quad \dots(11.6.14)$$

11.7 Magnification :

Definition : Magnification (m , say) =

$$\frac{\text{size of the image}}{\text{size of the object}}$$

when $m > 1$, image is magnified.

when $m = 1$, image and object have the same size

when $m < 1$, image is diminished.

We shall find m for different cases :

(a) Concave mirror :

(i) *Real image* :

(Refer Fig. 11.10)

Draw an incident ray AP from A, which after reflection, will pass through PA_1 (since A_1 is the image of A, any ray coming out of A will travel through A_1). Thus PA_1 is the corresponding reflected ray.

In the similar triangles APB and A_1PB_1

$$\frac{A_1B_1}{AB} = \frac{PB_1}{PB}$$

$$\text{or, } m = \frac{PB_1}{PB}$$

$$= \frac{-v}{-u} \quad (\text{by sign convention})$$

$$\therefore m = \frac{v}{u} \quad \dots(11.7.1)$$

(ii) *Virtual image* :

Refer Fig. 11.11

Draw an incident ray AP, which will be reflected along PE. However when PE is produced backwards, it will meet at A_1 - which is the image of A.

In the similar triangles APB and A_1PB_1

$$\frac{A_1B_1}{AB} = \frac{PB_1}{PB}$$

$$\text{or, } m = \frac{v}{-u} \quad \dots(11.7.2)$$

(b) *Convex mirror* :

Refer Fig. 11.12

Draw an incident ray AP, which will be reflected along PE. However, PE, when produced backwards, will meet at the image A_1 .

In the similar triangles APB and A_1PB_1 :

$$\frac{A_1B_1}{AB} = \frac{PB_1}{PB}$$

$$\text{or, } m = \frac{+v}{-u}$$

$$= -\frac{v}{u} \quad \dots(11.7.3)$$

11.8 Nature, Position and Size of image

(a) *Concave mirror* :

(i) *Object of infinity* :

Since the object is at infinity, or a very long distance from the mirror, the rays, reaching the mirror, are parallel.

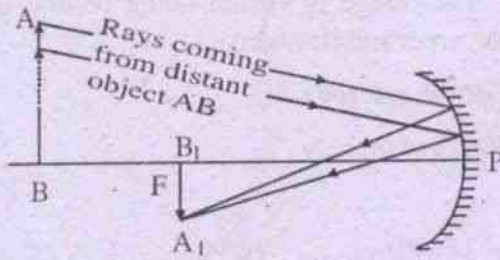

Object at infinity

Fig. 11.13

Let these incident parallel rays from A are not parallel to the Principal axis. After reflection, these rays intersect at A_1 - on the focal plane of the mirror. Thus A_1B_1 is the image.

Mathematically,

$$\frac{1}{\infty} + \frac{1}{u} = \frac{1}{f}$$

$$\therefore u = f$$

$$\text{and } m = \frac{v}{u}$$

$$= \frac{\infty}{f} \approx 0$$

Hence the image is real, inverted and very diminished.

(ii) Object beyond C :

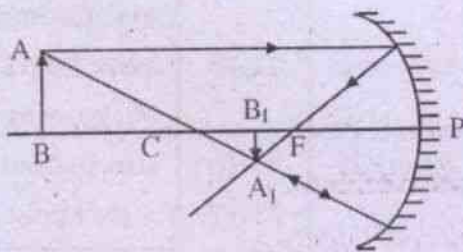

Object beyond C

Fig 11.14

The object AB is placed beyond C, but not far away.

The image A_1B_1 is real, inverted and diminished (since $v < u$) and located between F & C.

(iii) Object at C :

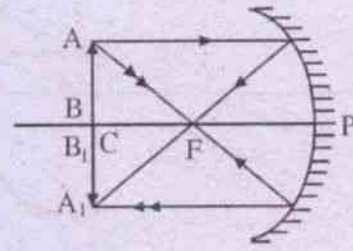

Object at C

Fig. 11.15

Using the formula

$$\frac{1}{f} = \frac{1}{v} + \frac{1}{u}$$

and putting here $u = PB = -2f$ and focal length $= PF = -f$, we have

$$\frac{1}{f} = \frac{1}{v} - \frac{1}{2f}$$

$$\text{or, } \frac{1}{v} = -\frac{1}{2f}$$

$$\text{or, } v = -2f = PC$$

Hence the object and image are located at the same position (i.e., C). The image is real, inverted and of same size as the object ($m = \frac{2f}{2f} = 1$).

(iv) Object between F and C :

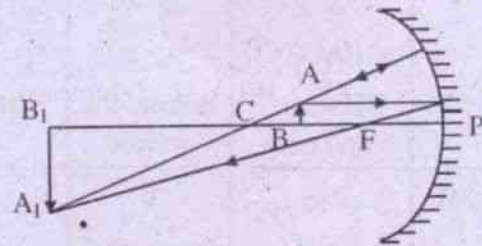

Object between F and C

Fig. 11.16

Image is real, inverted, magnified and located beyond C.

(v) *Object at focus :*

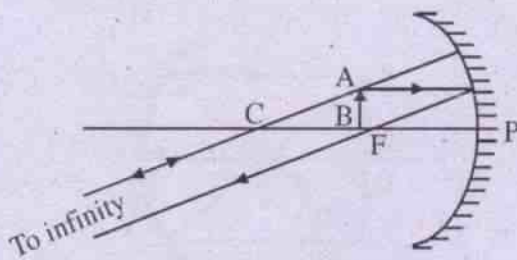

Object at Focus

Fig. 11.17

The reflected rays are found parallel and so they meet at infinity. Hence the image is formed at infinity. It is real, inverted and enlarged.

(vi) *Object between focus and pole :*

Refer Fig. 11.11

The image is virtual being behind the mirror, erect and enlarged.

(b) Convex mirror :

(i) *Object at infinity :*

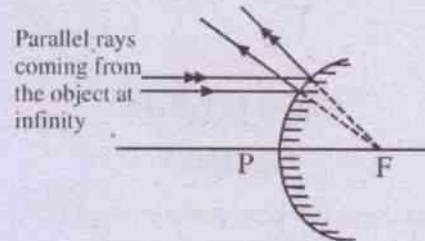

Fig. 11.18 (Object at infinity)

Image is formed at F, behind the mirror. It is virtual, erect and diminished.

(ii) *Object between infinity and pole :*

Refer Fig. 11.12

Image is formed behind the mirror. It is virtual, erect and diminished.

11.9 Summary of results :

Nature, Position and Size of image

Mirror	Position of object	Position of image	Nature of image	Size	Ref. Fig. No.	Remark
Concave	∞	F	Real, inverted	diminished	11.13	As the object moves from ∞ to F, the image move from F to ∞ , growing in size, in front of the mirror.
	Between ∞ and C	Between F & C	"	"	11.14	
	At C	At C	"	same size	11.15	
	Between C & F	Between C & ∞	"	Enlarged	11.16	
	At F	At ∞	"	"	11.17	
	Between F and pole	Behind the mirror	Virtual, erect	"	11.11	
	Convex	∞	F	"	Diminished	11.18
Between ∞ and pole		Between F and pole	"	"	11.12	

11.10 Conjugate points :

Two points on the principal axis are said to be conjugate to each other, if the object placed at one point, gives the image at the other and vice versa.

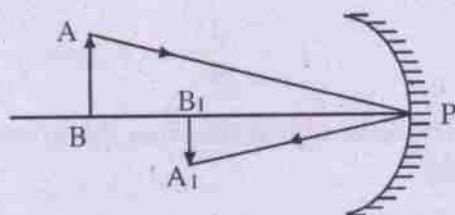

Conjugate Points

Fig. 11.19

Example: Let $PB = \text{object distance} = u$

$PB_1 = \text{image distance} = v$

AB is the object & A_1B_1 , its image. Now if we interchange the position of the object to A_1B_1 , then its image will be formed at AB ; because B and B_1 are conjugate points - thus u becoming v and v becoming u .

11.11: Identification of mirrors :

A mirror (plane / convex / concave) can be identified by knowing the image formed by it. Suppose we hold the mirror, to be identified, close to the object. Then if the mirror produces an erect and magnified image, the mirror is concave.

The identification - tests can be tabulated as follows :

Nature of image	Type of mirror
Erect, same size as object	Plane
Erect, magnified (when object is held near to the mirror)	Concave
Erect, diminished (whatever the position of the object may be)	Convex

11.12: Uses of spherical mirrors :

(a) *Concave mirror :*

Shaving glass, Reflector (for table lamps)
Doctor's ophthalmoscope.

(b) *Convex mirror :*

Viewfinder of an automobile
Reflector (for street light)

11.13: Spherical aberration :

We normally use spherical mirrors, having small aperture. However, if a spherical mirror is having wide aperture, all the rays, falling on it, will not come to a single focus after reflection. This is known as spherical aberration. This defect can be avoided either by using spherical mirrors of small aperture or by using paraboloidal mirror.

11.14: Hints for solving numerical problems:

- Put the data (i.e. numerical values) given in the problem with their proper sign and then use them in the $u - v$ relation.
- Do not put any sign for any measurement (like u , v , f etc), unless its numerical value is given.

Note: Solve a problem following the above rules. Then draw necessary conclusion basing on the sign of the numerical result, obtained after solving a problem.

The conclusions are :

- If the numerical result of f or r is -ve, the mirror is concave. Similarly +ve sign would mean convex mirror.
- If the numerical result of magnification is -ve, the image is real and inverted and is formed in front of the mirror. However if m is +ve, the image is virtual, erect and is formed behind the mirror.

Ex.11.1: An object is placed 28 cm from a concave mirror whose focal length is 10 cm. Find where the image is ? Is it real or virtual ?

Soln.

Given $u = 28 \text{ cm}$

$f = 10 \text{ cm}$

By sign convention

$u = -28 \text{ cm}$

$f = -10 \text{ cm}$

$v = ?$

Using $\frac{1}{v} + \frac{1}{u} = \frac{1}{f}$, we have

$$\frac{1}{v} - \frac{1}{28} = -\frac{1}{10}$$

or,
$$\frac{1}{v} = \frac{1}{28} - \frac{1}{10}$$

$$= \frac{-9}{140}$$

$$\therefore v = -15.56 \text{ cm}$$

The -ve sign shows that the image is formed on the same side as the object, i.e., in front of the mirror. So the image is real and inverted.

Ex.11.2: An object is at a distance of 10 cm from a mirror and the image of the object is at a distance of 30 cm from the mirror on the same side as the object. Is the mirror concave or convex? What is the focal length?

Soln.

Given $u = 10 \text{ cm}$

$v = 30 \text{ cm}$

By sign convention

$u = -10 \text{ cm}$

$v = -30 \text{ cm}$

$f = ?$

Substituting the values in $\frac{1}{f} = \frac{1}{v} + \frac{1}{u}$, we get

$$\frac{1}{f} = -\frac{1}{30} - \frac{1}{10}$$

$$= \frac{-4}{30}$$

$$\therefore f = \frac{-15}{2} = -7.5 \text{ cm}$$

The -ve sign shows that the mirror is concave.

Ex.11.3: The image of an object in a convex mirror is 4 cm from the mirror. If the mirror has a radius of curvature of 24 cm, find the object position and magnification.

Soln.

Given * $v = 4 \text{ cm}$

$f = r/2 = 12 \text{ cm}$

Applying sign convention,

$v = +4 \text{ cm}$

(Since in a convex mirror, the image is always behind the mirror)

$f = +12 \text{ cm}$

Using $\frac{1}{f} = \frac{1}{v} + \frac{1}{u}$, we have

$$\frac{1}{12} = \frac{1}{4} + \frac{1}{u}$$

or
$$\frac{1}{u} = \frac{1}{12} - \frac{1}{4}$$

$$= \frac{-2}{12}$$

or, $u = -6 \text{ cm}$

Since u is -ve sign, the object is 6 cm in front of the mirror.

$$\begin{aligned}\text{Magnification} = m &= \left| \frac{u}{v} \right| \\ &= \frac{4}{6} = 0.67\end{aligned}$$

Hence the image is two-thirds as high as the object.

Ex.11.4: An erect (up right) image, three times the size of the object, is obtained with a concave mirror of radius of curvature 36 cm. What is the position of the object ?

Soln.

$$\text{Given } f = r/2 = 18 \text{ cm}$$

$$m = 3 = \frac{v}{u}$$

By sign convention, $f = -18$ cm.

Further since image is erect, the object and image should be in the opposite sides of the mirror. But u is -ve. So v should be +ve.

Thus $u = -x$ (say)

Then $v = +3x$

Applying $\frac{1}{v} + \frac{1}{u} = \frac{1}{f}$, we obtain,

$$\frac{1}{3x} - \frac{1}{x} = -\frac{1}{18}$$

$$\text{or, } \frac{-2}{3x} = -\frac{1}{18}$$

$$\therefore x = 12 \text{ cm}$$

Then $u = -12$ cm.

Thus the image is formed in front of the mirror at 12 cm from the mirror.

Ex.11.5: A concave mirror produces a magnification of 4 times as great when the object is 25 cm from the mirror, as it was with the object at 40 cm from the mirror. The image in each

case is real. Find the focal length of the mirror.

$$\text{We know } \frac{1}{v} + \frac{1}{u} = \frac{1}{f}$$

Multiplying by u throughout,

$$\frac{u}{v} + 1 = \frac{u}{f}$$

$$\text{or, } \frac{u}{v} = \frac{u-f}{f}$$

$$\therefore m = \frac{v}{u} = \frac{f}{u-f}$$

$$\text{Now } m_1 = \frac{f}{-25-f}$$

$$\text{and } m_2 = \frac{f}{-40-f}$$

$$\therefore \frac{m_1}{m_2} = \left(\frac{f}{25+f} \right) \left(\frac{40+f}{f} \right)$$

$$= \frac{40+f}{25+f}$$

$$= 4 \quad (\text{By the question})$$

$$\therefore 100 + 4f = 40 + f$$

$$\text{or, } 3f = -60$$

$$\therefore f = -20 \text{ cm.}$$

The -ve sign confirms that the mirror is concave.

SUMMARY

1. A spherical mirror is a reflecting surface, which forms a part of the sphere.
2. For all spherical mirrors,

$$r = 2f$$

• where r = radius of curvature

f = focal length

3. For all spherical mirrors,

$$\frac{1}{u} + \frac{1}{v} = \frac{2}{r} = \frac{1}{f}$$

where u = object distance

v = Image distance

4. Magnification = $m = \frac{\text{Size of the image}}{\text{Size of the object}}$

5. Sign convention:

Taking the pole of the mirror as origin,
distances measured towards left of
the origin are -ve

and distance measured towards right of
the origin are +ve.

6. Image :

When a beam of light diverging
from a point after reflection (or refraction)
actually converges to a second point, then
the second point is called the **real image**
of the first point.

When a beam of light diverging
from a point after reflection (or refraction)
appears to diverge from a second point,
then the second point is called the **virtual
image** of the first.

MODEL QUESTIONS

A. Multiple Choice Type Questions :

1. The picture seen in the screen of a pinhole camera is
 - a) An image
 - b) A shadow
 - c) Neither an image nor a shadow
 - d) Both an image and a shadow
2. An object 5 cm tall is placed 1 m from a concave spherical mirror which has a radius of curvature of 20 cm. The size of the image is
 - a) 0.11 cm
 - b) 0.50 cm
 - c) 0.55 cm
 - d) 0.60 cm
3. A dice is placed with its one edge parallel to the principal axis between the principal focus and the center of curvature. Then the image has the shape of
 - a) cube
 - b) rectangular parallelepiped
 - c) barrel shaped
 - d) spherical
4. A boy stands straight in front of a mirror at a distance of 30 cm away from it. He sees his erect image whose height is $\frac{1}{5}$ th of his real height. The mirror he is using is
 - a) plane mirror
 - b) convex mirror
 - c) concave mirror
 - d) plane-concave mirror
5. The relation between magnification m , the object distance u and focal length f of the mirror is
 - a) $m = \frac{f-u}{f}$
 - b) $m = \frac{f}{f-u}$
 - c) $m = \frac{f+u}{f}$
 - d) $m = \frac{f}{f+u}$
6. A concave mirror of focal length f produces an image n times the size of the

object. If the image is real, then the distance of the object from the mirror is

- a) $(n-1)f$
 - b) $\left(\frac{n-1}{n}\right)f$
 - c) $\left(\frac{n+1}{n}\right)f$
 - d) $(n+1)f$
7. Reflectors used in solar cooker are
 - a) convex
 - b) concave
 - c) plane
 - d) cylindrical
 8. An object of length 4 cm is kept on the principal axis of a convex mirror at a distance of f . The size of the image formed is
 - a) 2 cm
 - b) 8 cm
 - c) 6 cm
 - d) 4 cm
 9. A concave mirror has radius of curvature of 1m. Light from a distant star is incident on the mirror. The distance of the image of the star from the mirror is
 - a) 0.5 m
 - b) 1 m
 - c) 2 m
 - d) 0.25 m
 10. A convex mirror is used to form an image of a real object. Then tick the wrong statement
 - a) The image lies between the pole and the focus
 - b) The image is diminished in size
 - c) The image is erect
 - d) The image is real
 11. A dentist has small mirror of focal length 16 mm. He views the cavity in the tooth if a patient by holding the mirror at a distance of 8 mm from the cavity. The magnification is
 - a) 1
 - b) 1.5
 - c) 2
 - d) 3
- ### B. Answer as directed :
1. Is the path of light rays reversible ? (Yes/No)
 2. What is the focal length of a plane mirror ?

3. Radius of curvature of a plane mirror is ___.
4. The image can be seen from any position of the line joining the eye to the image ___ the surface of the mirror.
5. What is the angle of reflection, when a ray of light is incident normally on a plane mirror?
6. The least distance between an object and real image formed by a concave mirror of focal length f is zero when the object is at $2f$ from the mirror (True/False).

7. A person and a plane mirror both approach each other with a velocity x . What is the velocity of the image?
8. A diminished virtual image can be obtained only in ___ type of mirror.
9. Which one is having a more field of view: convex or concave or plane mirror?

C. Very Short Answer Type Questions :

1. Why a concave mirror can be used as a shaving mirror?
2. Why a convex mirror can be used as a driving mirror?
3. Under what conditions, the formula "radius of curvature is twice focal length" for a spherical mirror holds good?
4. Why can't you photograph a virtual image?
5. Where will you get the image of an object at infinity for a concave mirror?

D. Short Answer Type Questions :

1. You are asked to decide whether a given mirror is concave, convex or plane, without touching it. What method would you adopt to ascertain this?
2. What difficulty a car driver will face, if he uses a concave mirror instead of convex mirror to see the roadway behind him?
3. Show mathematically where the object should be placed so that the size of the image will be equal to the size of the object in case of a concave mirror. Give ray diagram.
4. When an object is moved from very long distance to the focus, in what way the nature and size of the image will be affected, in case of a concave mirror?

5. What do you mean by linear magnification? What are its limiting values for a convex mirror?

6. You have learnt that plane and convex mirrors produce virtual images of objects. Can they produce real images under some circumstance? Explain.

[CBSE Sample Paper]

7. A virtual image, we always say, cannot be caught on a screen. Yet when we 'see' a virtual image we are obviously bringing it on to the screen (i.e., the retina) of our eye. Is there a contradiction?

[CBSE Sample Paper]

E. Numerical Problems :

1. An object is placed 10 cm in front of a concave mirror of focal length 15 cm. Find the image position and the magnification.
2. Describe the image produced by placing an object 30 cm in front of a convex mirror having a focal length of 10 cm.
3. At what distance from a concave mirror of focal length 15 cm must an object be placed so that the linear size of the image be half that of the object?
4. Plot the u - v graph from the following values:
 u 250, 200, 150, 120, 100, 80, 70 cm
 v 60.9, 65.2, 73.2, 84, 96.5, 127.5, 166.5 cm.
 Find out the focal length from the graph.
5. An image produced by a convex mirror is $\frac{1}{n}$ th of the size of the object. Prove that the object must be at a distance of $(n-1)f$ from the mirror, where f is the focal length of the mirror.
6. Calculate the distance of an object of height 'h' from a concave mirror of focal length 10 cm, so as to obtain a real image of magnification 2. [CBSE 2008]

F. Long Answer Type Questions :

1. Establish a relation between radius of curvature and focal length for a concave mirror.
2. Establish a relation between u , v and f for a concave mirror.

3. Establish a relation between
(i) r and f
and (ii) u , v and f
for a convex mirror.
 4. Find out the formulae for magnification for concave and convex mirrors. Give ray-diagrams.
 5. Describe the appearance and position of the image produced by a concave mirror as the object moves from infinity towards the mirror, with the help of ray-diagrams.
- G. Correct the following sentences :**
1. Convex mirror can be used as a shaving mirror.
 2. Plane mirror is used in motor cycles for rear view.
 3. Concave mirror produces virtual image for all positions of the object.
 4. The focal length of a concave mirror is one-third of its radius of curvature.
 5. Diminished virtual image can be produced by a concave mirror for all positions of the object.

ANSWERS

A. Multiple Choice Type Questions :

1. (c) 2. (c) 3. (b) 4. (b) 5. (b) 6. (c) 7. (b) 8. (a)
9. (a) 10. (d) 11. (c)

- B. 1. Yes 2. Infinity 3. Infinity 4. Intersects 5. 0° 6. True 7. $3x$ 8. Convex spherical
9. Convex

E. Numerical Problems :

1. 30 cm, 3
2. Virtual, 7.5 cm behind the mirror, 0.25
3. 45 cm
6. -15 cm

12

Refraction, Dispersion and Lens

12.1 Refraction :

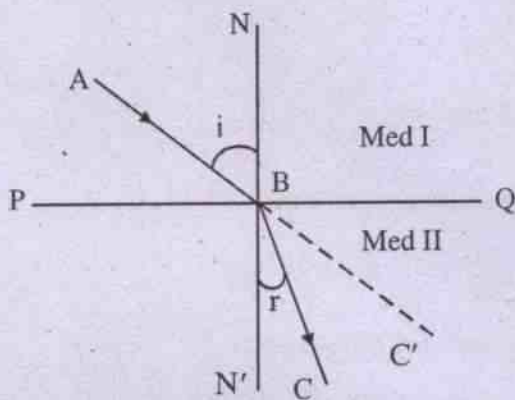

Fig. 12.1

- AB = Incident ray
B = point of incidence
BC = Refracted ray
NBN' = Normal at the point of incidence to the interface (or, refracting surface)
 $\angle ABN =$ Angle between incident ray & the normal
= Angle of incidence
= i
 $\angle CBN' =$ Angle between refracted ray and the normal
= Angle of refraction
= r

Let us consider two media (Medium I - say, air) and (Medium II - say, glass). The face, separating the two media, is called the interface (PQ). Let a ray of light AB is travelling from medium I to Medium II (in this case from air to glass i.e. rarer to denser medium).

Then the ray will change its direction at the point of incidence B. This phenomenon is called refraction. In the absence of the interface, the incident ray AB would have proceeded straight along BC'. However due to refraction, its direction changes. If the medium I is rarer than medium II, i.e. light is passing from rarer to denser medium, the refracted ray would move closer to the normal (as in the case of air to glass). However, in the reverse case, i.e., when light travels from denser to rarer medium (say, glass to air, or water to air), the refracted ray would move away from the normal.

The phenomenon of refraction is regulated by the following **laws of refraction** :

1. The incident ray, the refracted ray and the normal at the point of incidence lie in one plane.
2. Snell's law (or, the Law of Sines) : The sine of the angle of incidence bears a constant ratio to the sine of the angle of refraction, for any two media and a given colour of light.

$$\text{Mathematically } \frac{\sin i}{\sin r} = {}_1\mu_2 \quad \dots 12.1.1$$

where μ is a constant, known as the refractive index and 1,2 attached to μ indicate that the light is passing from medium 1 to medium 2.

In the present case, since light is passing from air (a) to glass (g), μ should be represented as ${}_a\mu_g$.

${}_1\mu_2$ can be defined in another way, basing on Huygen's wave theory of light, as

$${}_1\mu_2 = \frac{v_1}{v_2} \quad \dots 12.1.2$$

where v_1 = velocity of light in the 1st medium

v_2 = velocity of light in the 2nd medium

$${}_1\mu_2 = \frac{(v_1/C)}{(v_2/C)} \quad \dots 12.1.3$$

where C = velocity of light in air (or, Vacuum)

The absolute refraction index μ of any medium is defined as :

$$\mu = C/v \quad \dots 12.1.4$$

where v = velocity of light in the medium

Using eqn. (12.1.4) in (12.1.3), we get

$$\begin{aligned} {}_1\mu_2 &= \left(\frac{1}{\mu_1}\right) \bigg/ \left(\frac{1}{\mu_2}\right) \\ &= \frac{\mu_2}{\mu_1} \quad \dots 12.1.5 \end{aligned}$$

Comparing eqns. 12.1 (1 & 5), we get

$$\frac{\sin i}{\sin r} = \frac{\mu_2}{\mu_1}$$

$$\text{so that } \mu_1 \sin i = \mu_2 \sin r \quad \dots 12.1.6$$

In case the angles i and r are small, we put

$$\sin i = i$$

$$\text{and } \sin r = r$$

so that the above eqn reduces to

$$\mu_1 i = \mu_2 r \quad \dots 12.1.7$$

An important formula regarding refractive index can be derived as follows :

$$\frac{\mu_2}{\mu_1} \times \frac{\mu_1}{\mu_2} = 1 \quad \dots 12.1.8$$

$$\text{But } \frac{\mu_2}{\mu_1} = {}_1\mu_2 \text{ by eqn. (12.1.5)}$$

$$\text{and similarly } \frac{\mu_1}{\mu_2} = {}_2\mu_1$$

$$\text{Substituting above in (12.1.8) } {}_1\mu_2 \times {}_2\mu_1 = 1$$

$$\text{so that } {}_1\mu_2 = 1/{}_2\mu_1 \quad \dots 12.1.9$$

Examples of refraction :

In nature, twinkling of stars can be explained by atmospheric refraction.

Further an interesting case of refraction and reflection is that : when a colourless glass, having the same refractive index as that of water, is fully immersed in water, it will be completely invisible since neither reflection nor refraction takes place.

Real depth and Apparent depth :

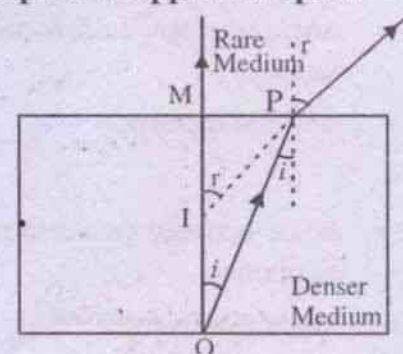

O = Point object

I = Image

$\angle MOP = \text{Angle of incidence} = i$

$\angle MIP = \text{Angle of refraction} = r$

MO = Real depth

MI = Apparent depth

$\sin i = MP/OP$

$\sin r = MP/IP$

$$\therefore D^{\mu}R = \frac{\sin i}{\sin r}$$

$$= \frac{MP/OP}{MP/IP} = \frac{IP}{OP}$$

If P is taken very close to M (i.e. for paraxial rays):

$$D^{\mu}R = \frac{IM}{OM}$$

$$\therefore R^{\mu}D = \frac{OM}{IM}$$

$$\text{Rarer } \mu_{\text{Denser}} = \frac{\text{Real depth}}{\text{Apparent depth}}$$

12.2 Total internal Reflection :

The basic condition for total internal reflection is that the ray must travel from denser to rarer medium (say, water to air). Then refraction will occur as follows :

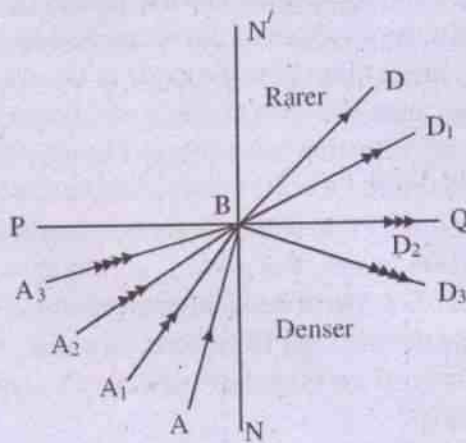

Total Internal Reflection
Fig. 12.2

Consider a ray AB, passing from denser to rarer medium. It will be deviated away from the normal NBN' obeying the laws of refraction and refracted along BD.

Now consider a ray A₁B with a greater angle of incidence. After refraction, it will pass along BD₁, coming closer to the interface BQ.

Table : Critical Angle (C)		
Incident ray	Phenomenon involved	Remark
AB	Refraction (BD)	$i < C$
A ₁ B	Refraction (BD ₁)	$i < C$
A ₂ B	Refraction (BD ₂)	$i = C$ critical phenomena
A ₃ B	Reflection (BD ₃)	$i > C$ This reflection is total, since no part of the incident ray is refracted

Note : A₂B ↔ BD₂ is the critical case, since this separates the refraction region from the reflection region.

If we take another incident ray, A₂B, with a still greater angle, such that its refracted ray BD₂ just coincides with the interface BQ (i.e. the refracted ray grazes on the refracting surface), then the corresponding angle of incidence ($< A_2BN$) is called the critical angle (C). Thus BD₂ yields the greatest possible angle of refraction (i.e. 90°).

If now an incident ray A₃B for which the angle of incidence is greater than critical angle ($i > c$) is considered, it will have no chance of refraction; instead it will be fully reflected-back

to its original denser medium along BD_3 , obeying the laws of reflection (i.e., angle of incidence = angle of reflection : $\angle A_3BN = \angle D_3BN$)

The Snell's law, as applied to critical angle gives

$$\text{Denser } \mu_{\text{Rarer}} = \frac{\sin i}{\sin r}$$

$$= \frac{\sin C}{\sin 90}$$

$$= \sin C$$

$$\therefore \text{Rarer } \mu_{\text{Denser}} = \frac{1}{\sin C} \quad \dots 12.2.10$$

This equation shows that critical angle depends upon the two media involved and the colour of light. Mirage is an example of total internal reflection in nature.

12.3: Conditions for total internal reflection :

- (i) The incident ray should move from denser to rarer medium.
- (ii) The angle of incidence must exceed the critical angle for the two media for a given colour of light.

12.4: Optical Fibre:

An optical fibre is a flexible, transparent fibre, made by drawing glass (silica) or plastic to a diameter slightly thicker than that of human hair ($\sim 10^{-6} m$).

Optical fibres typically include a transparent core surrounded by a transparent cladding of dielectric material with a lower refractive index, as shown in fig.12.3 (d). The boundary between the core and the cladding may be abrupt, in step-index fibre, or gradual, in graded-index fibre. Bundle of such fibres forms a light pipe (or a tube of fibres) as shown in fig. 12.4.1(c).

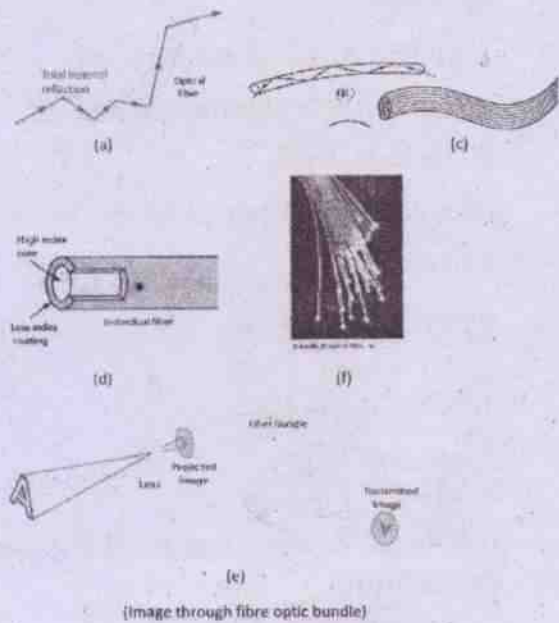

Fig.12.3

Principle of Operation:

Optical fibre works on the principle of total internal reflection. When light travelling in an optically dense medium hits a boundary at a steep angle larger than the critical angle for the boundary), the light is completely reflected. This phenomenon is called total internal reflection. Because of small radius of fibre, once the light is introduced such that the light makes a glancing incidence on the cladding wall (within the confines of the numerical aperture (NA) of the fibre) then the angle of incidence is greater than the critical angle and hence total internal reflection takes place. The sine of this maximum angle is the numerical aperture (NA) of the fibre. Fibre with a larger NA requires less precision to splice and work with than with a smaller NA. Due to total internal reflection light travels through the fibre core, bouncing back and forth off the boundary between the core and cladding.

Types of Fibre:

Optical fibres are broadly of two types;
(i) Multi-mode fibre (ii) Single mode fibre

(i) Multi-mode fibre:

Fibre with large core diameter (greater than 10 micrometers) are called multi-mode fibre. These can be analyzed by geometrical optics. In step-index multi-mode fibre, rays of light are guided along the fibre core by total internal reflection. Rays that meet the core-cladding boundary at a high angle (measured with respect to the normal to the boundary), greater than critical angle for this boundary, are completely reflected. The critical angle is determined by the difference in index of refraction between the core and cladding materials.

$$[\text{rarer } \mu \text{ denser} = \frac{1}{\sin C} = \frac{\mu d}{\mu r}]$$

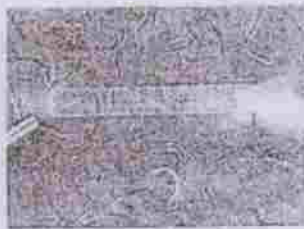

Rays that meet the boundary at low angle are refracted from the core into the cladding, and do not convey light and hence information along the fibre. The critical angle determines the acceptance angle of the fibre, often reported as numerical aperture (NA). A high NA allows light to propagate down the fibre in rays both close to the axis and at various angles, allowing efficient coupling of light into the fibre. However, this high NA increases the amount of dispersion as rays at different angles have different path lengths and therefore take different times to traverse the fibre.

In graded-index fibre, the index of refraction in the core decreases continuously between the axis and cladding. This causes light rays to bend smoothly as they approach the cladding, rather than reflecting abruptly from the core-cladding boundary. The resulting curved paths reduce multi-path dispersion

because high angle rays pass more through the lower index periphery of the core, rather than high-index centre. The index profile is chosen to minimise the difference in axial propagation speeds of the various rays in fibre.

(ii) Single-mode fibre:

Fibre with core diameter less than about ten times the wavelength of the propagating light cannot be modelled using geometric optics. Instead, it must be analyzed as an electromagnetic structure, by solution of Maxwell's equations as reduced to electromagnetic wave equation. The electromagnetic analysis may also be required to understand the behaviours such as speckle that occur when coherent light propagates in multi-mode fibre. As an optical waveguide, the fibre supports one or more confined transverse modes by which light can propagate along the fibre. Fibre supporting only one mode is called single-mode or mono-mode fibre. The behaviour of large-core multi-mode fibre can also be modelled using the wave equation, which shows that such fibre supports more than one mode of propagation. The results of such modelling of multi-mode fibre approximately agree with the predictions of geometric optics, if the fibre core is large enough to support more than a few modes.

The wave guide analysis shows that the light energy in the fibre is not completely confined in the core. Instead, especially in single-mode fibres, a significant fraction of the energy in the bound mode travels in the cladding as an evanescent wave. The most common type of single-mode fibre has a core diameter of 8-10 micrometers and is designed for use in near infrared. The mode structure depends on the wavelength of the light used, so that this fibre actually supports a small number of additional modes at visible wavelengths. Multi-mode fibre, by comparison, is manufactured with core diameters as small as 50 micrometers and as large as hundreds of micrometers.

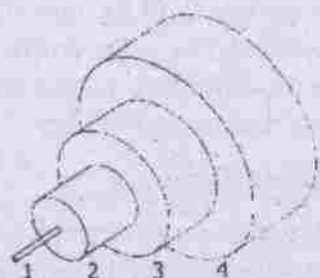

The structure of a typical single-mode fiber.

1. Core: 8 μm diameter
2. Cladding: 125 μm dia.
3. Buffer: 250 μm dia.
4. Jacket: 400 μm dia.

Special-purpose fibre:

Some special-purpose optical fibre is constructed with a non-cylindrical core and/or cladding layer, usually with an elliptical or rectangular cross-section. These include polarisation-maintaining fibre and fibre designed to suppress whispering gallery mode propagation. Polarisation-maintaining fibre is unique type of fibre that is commonly used in fibre optic sensors due to its ability to maintain the polarisation of the light inserted into it.

Photonic-crystal fibre is made with a regular pattern of index variation (often in the form of cylindrical holes that run along the length of the fibre). Such fibre uses diffraction effects instead of or in addition to total internal reflection, to confine light to fibre's core. The properties of fibre can be tailored to a wide variety of applications.

Uses:

Optical fibre has a large number of useful applications in different fields. 1. **Communication:** Optical fibre can be used as a medium for telecommunication and computer networking because it is flexible and can be bundled as cables. It is especially advantageous for long distance communications, because light propagates through the fibre with little attenuation compared to electrical cables.

For short distance application, such as network in an office building, fibre optic cabling can save space in cable ducts. This is because a single fibre can carry much more data than electrical cables. Optical fibre is also immune to electrical interference; there is no cross-talk between signals in different cables, and no pick up of environmental noise. There is no danger of ignition.

2. Imaging optics (medical & industrial use):

Fibre optic Imaging uses the fact that the light striking the end of an individual fibre will be transmitted to the other end of that fibre. Each fibre acts as a light pipe, transmitting the light from that part of the image along the fibre. If the arrangement of the fibres in the bundle is kept constant then the transmitted light forms a mosaic image of the light which struck the end of the bundle. A coherent bundle of fibres is used, sometimes along with lenses, for a long, thin imaging device called an **endoscope**, which is used to view objects through a small hole. Medical endoscopes are used for minimally invasive exploratory or surgical procedures. Industrial endoscopes (fibrescope or borescope) are used for inspecting anything hard to reach, such as jet engine interiors. Many microscopes use fibre optic light sources to provide intense illumination of samples being studied.

3. Advantages over copper wiring:

(a) **Broad bandwidth:** A single optical fibre can carry over 30,00,000 full-duplex voice calls or 90,000 TV channels.

(b) **Immunity to electromagnetic interference:** Light transmission through optical fibre is unaffected by electromagnetic radiations nearby. As optical fibre is electrically non-conductive so it does not pick up electromagnetic signals. Information travelling inside the optical fibre is immune to electromagnetic interference, even to electromagnetic pulses generated by nuclear devices.

(c) **Low attenuation loss over long distances:** Attenuation loss can be as low as 0.2 dB/km in optical fibre cables, allowing transmission over long distances without need for repeaters.

(d) **Electrical insulator:** Optical fibres do not conduct electricity, preventing problems with ground loops and conduction of lightning. Optical fibres can be strung on poles alongside high voltage power cables.

(e) **Material cost:** Optical cables are of low cost compared to copper cables. Also there is chance of theft of copper cables but optical fibres have no such theft chance.

12.5: Prism : Preliminaries

Prism is a transparent medium, lying between two plane faces inclined at an angle.

Refracting faces are the two inclined planes of a prism.

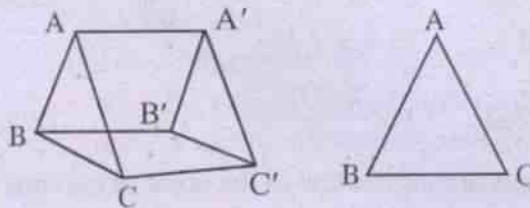

Fig. 12.3 : Prism

AA' B'B & AA' C'C = Two refracting faces

AA' = Refracting edge

$\angle BAC =$ Angle of prism = (A, say)

ABC = Principal Section

BB'C'C = Base of the Prism

Refracting edge (or, simply edge) of a Prism is the line along which the two refracting faces meet.

Angle (or, refracting angle) of a prism is the angle of inclination between the two refracting faces.

Principal section is any plane, perpendicular to the edge of the prism.

The face of the prism, which is opposite to the refracting edge, is called the base of the prism.

12.6 Refraction through Prism :

We shall here consider the refraction through the Principal section of a prism.

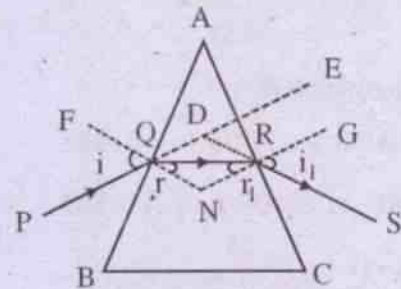

Fig. 12.4: Refraction through Principal section of a prism

At the point Q :

PQ = Incident ray

QR = Refracted ray

FN = Normal to the face AB at the point of incidence Q.

$\angle PQF =$ Angle of incidence = i

$\angle RQN =$ Angle of refraction = r

At the point R :

QR = Acts as incident ray

RS = Refracted (emergent) ray

GN = Normal to AC at R

$\angle QRN = r_1$ (say)

$\angle GRS = i_1$ (say)

Def : Angle of deviation = Angle between the incident ray (PQ) and the emergent ray (RS)

$= \angle EDS = D$ (say)

In the triangle NQR : $\hat{QNR} + r + r_1 = 180^\circ$

$\therefore \hat{QNR} = 180^\circ - (r + r_1)$...12.5.1

In the Quadrilateral QDRN :

$\angle DQN + \angle QNR + \angle DRN + \angle RDQ = 360^\circ$

$$\begin{aligned} \text{or, } i + [180 - (r + r_1)] + i_1 + \angle RDQ &= 360^\circ \\ \text{using } \angle DQN = \angle FQP = i \text{ being} \\ \text{opposite, } \angle DRN = \angle GRS = i_1 \\ \text{being opposite and eqn. 12.5.1} \\ \therefore (i + i_1) - (r + r_1) &= 180 - \angle RDQ \\ &= \angle RDE \\ &= D \quad \dots 12.5.2 \end{aligned}$$

In the triangle AQR :

$$\begin{aligned} \angle AQR + \angle ARQ + A &= 180 \\ \text{or } (90 - r) + (90 - r_1) + A &= 180 \\ \text{or } A - (r + r_1) &= 0 \\ \therefore r + r_1 &= A \quad \dots 12.5.3 \end{aligned}$$

Substituting (12.5.3) in (12.5.2)

$$\text{we get: } (i + i_1) = D + A \quad \dots 12.5.4$$

i , i_1 and D can be plotted graphically, as in Fig. 12.5. This is known as the i - D curve.

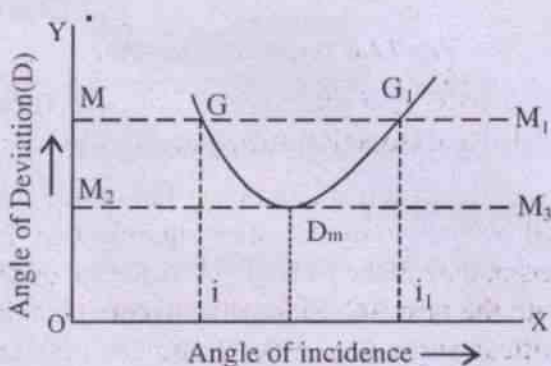

Fig. 12.5 (i - D curve)

The graph can be analysed as follows :

Let us draw a horizontal line, say MM_1 , for an angle of deviation, say, θ . Then MM_1 will intersect the i - D curve at two points G and G_1 . When we drop normals from G and G_1 on the X -axis, we get two values of angle of incidence (say, i and i_1).

This illustrates that for a given value of angle of deviation, there are two values of angle

of incidence.

However, if the horizontal line MM_1 is lowered, we will reach a particular stage, where there will be only one value of angle of incidence (Refer M_2M_3 for which the angle of incidence is single-valued, i.e., $i = i_1$ and angle of deviation is minimum, denoted by D_m).

As has been shown in the i - D curve, the two angles of incidence become equal and correspondingly their angles of refraction (r and r_1) are also same in the minimum deviation position.

Thus, when $D = D_m$

$$i = i_1 \quad \dots 12.5.5$$

$$\text{and } r = r_1$$

Substituting these values in eqns 12.5(3 & 4) :

$$2r = A$$

$$\text{so that } r = A / 2 \quad \dots 12.5.6$$

$$\text{and } 2i = A + D_m$$

$$\text{so that } i = \frac{A + D_m}{2} \quad \dots 12.5.7$$

Applying Snell's law to the point of incidence Q , we get

$$\mu = \frac{\sin i}{\sin r}$$

$$= \frac{\sin \frac{A + D_m}{2}}{\sin \frac{A}{2}} \quad \dots 12.5.8$$

12.7: Deviation Produced by a prism of small angle : Thin Prism

Eq. (12.5.3) gives

$$A = r + r_1$$

When the angle of the Prism (A) is very small, r and r_1 will be small. Consequently i and i_1 will also be small, as per Snell's law.

We have $\frac{\sin i}{\sin r} = \mu$

and $\frac{\sin i_1}{\sin r_1} = \mu$

Since i, i_1, r and r_1 are small, the above two equations lead to :

$$\frac{i}{r} = \frac{i_1}{r_1} = \mu$$

$$\therefore i = r\mu$$

and $i_1 = r_1\mu$

In (12.5.4), we had obtained

$$i + i_1 = D + A$$

Substituting (12.6.1) above :

$$\mu(r + r_1) = D + A$$

or, $\mu A = D + A$ (by eq.12.5.3)

$$\therefore D = (\mu - 1)A \quad \dots 12.6.2$$

In eq. 12.5.4, we had seen that deviation depends on angle of incidence for prisms generally. However for thin Prisms, eq. 12.6.2 shows that deviation depends on the angle of Prism, but not on the angle of incidence. Of course, in both types, the incident ray bends towards the base of the Prism.

12.8: Application of Total Internal Reflection to Prisms :

The Principle of total internal reflection has been applied to construct different types of prism to suit various needs.

While constructing glass prisms, the value of the corresponding critical angle should be taken care of.

We have, $\sin C = \frac{1}{\mu}$

Taking $\mu_g = 1.5$

We get $\sin C = \frac{2}{3}$

so that $C \approx 42^\circ$

Hence total internal reflection for glass-Prisms will take place, when the angle of incidence is greater than the critical angle of 42° .

The types of glass-Prisms of importance are :

- (a) Total Reflection Prism
- (b) Erecting Prism.

(a) *Total Reflection Prism :*

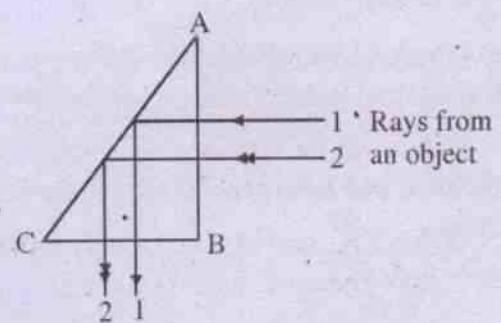

Fig. 12.6 Total Reflection Prism

ABC is a glass-prism, which is right-angled and isosceles, such that $AB = BC$.

Let rays from an object fall on the face AB normally; so that after entering into the prism, they make an angle of incidence of 45° with the face AC. Since this is more than the critical angle (i.e., $i > C$) and the rays are travelling from denser to rarer medium (glass to air) inside the Prism, there will be total internal reflection. These reflected rays will now emerge out of the face CB normally.

These rays are reflected totally. Hence the image so produced, will not suffer from any loss of intensity. Thus a bright image will be produced.

(b) *Erecting Prisms :*

These prisms convert inverted images into

erect images. So they are used in periscopes, telescopes, binoculars etc.

(i)

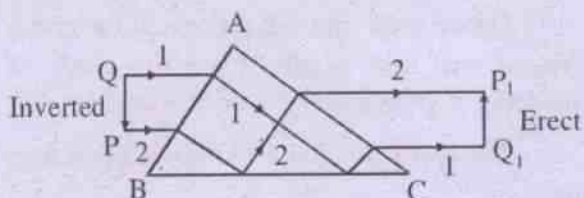

Fig. 12.7 (i) Erecting Prism

ABC is an isosceles right-angled glass prism with $\angle A = 90^\circ$ and $AB = AC$.

QP = Inverted position

P_1Q_1 = Erect image, obtained by the prism, due to total internal reflection on the face BC.

In this case, the total deviation is nil, since the incident and emergent rays have the same direction.

(ii)

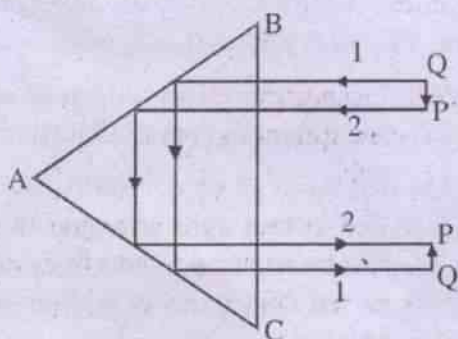

Fig. 12.7 (ii) Erecting Prism

ABC = Right angled isosceles prism

QP = Inverted position

P_1Q_1 = Erect image

The rays suffer total internal reflection twice - once in each in the face AC and AB.

Here the total deviation is 180° , since the incident and emergent rays are in opposite direction.

12.9: Dispersion :

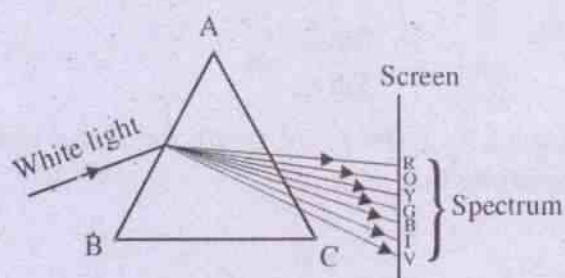

Fig. 12.8 Dispersion of light

ABC = Prism

VIBGYOR = Violet, Indigo, Blue, Green, Yellow, Orange, Red.

When monochromatic (or, simple) light falls on a Prism, we have seen that it bends towards the base of the Prism. However, if polychromatic (or compound) light falls on it, the light is not only deviated towards the base, but also splits into its component basic colours, which cannot be split further. For example, when white light is refracted through a Prism, the seven component colours are arranged as VIBGYOR - Violet colour being the most refrangible (i.e., the most deviated). The process of breaking-up of composite light into its fundamental component colours is known as dispersion and the orderly arrangement of colours is called the spectrum.

It should be noted that the Prism does not produce different colours, it simply separates the component colours that are contained in the incident light.

12.10: Spectrum :

Spectra can be of two kinds :

- Pure spectrum : In this case, the constituent colours are separated distinctly and visible clearly.
- Impure spectrum : Here the constituent colours practically overlap on each other.

12.11: Arrangement for pure spectrum :

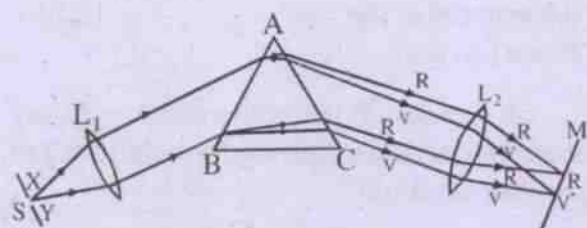

Fig.12.9 Pure Spectrum

S = Source of white light

XY = Narrow slit

L_1, L_2 = Two convex lenses

ABC = Prism (in minimum deviation position)

The conditions for formation of pure spectrum are :

- (1) The slit should be narrow
- (2) The Prism is to be kept in the minimum deviation position for the mean colour of light (yellow for white light).
- (3) Convex lens (L_1) is placed between slit and Prism to make the incident rays parallel.

Another achromatic convex lens (L_2) should be placed between the prism and the screen, so that the emergent rays of different colours will be focussed at different positions of the screen, thus, avoiding overlap of colours.

- (4) The refracting edge of the prism should be parallel to the slit.

A spectrometer is a compact optical instrument which is designed to get pure spectrum. This is also provided with suitable scales for measuring refractive index and some other physical quantities, relating to optics.

12.12: Classification of spectra

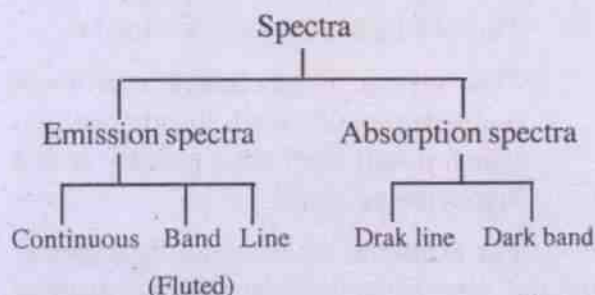

(a) Emission spectra : Let us consider the atoms or molecules that are kept inside a source of light. When they are supplied energy (by heating / bombarding with energetic particles etc.), then they get excited and move to higher energy-levels/states. These excited atoms/molecules emit light, when they fall back to their initial state.

The emission spectra are subdivided into three types : (i) Continuous (ii) Band (iii) Line spectra.

(i) Continuous spectra are given by :
 (1) incandescent solids; depending on their temperature
 (2) liquids and gases under large pressure.

Example : Incandescent electric lamp, electric arc, luminous coal gas flame, lime-light.

Nature : The colours are arranged in the spectrum in proper order from violet to red continuously without any break.

(ii) Band spectra : It is emitted by molecules and depend on the character of the molecules and the method of excitation.

The spectrum consists of broad luminous bands - each being sharp at one edge, but gradually shading off at the other end.

(iii) Line spectra : Atom is responsible for this type of spectrum. Different atoms give spectral lines of different colours : sodium gives two yellow lines. Hydrogen gives three spectral lines (red, green, violet).

(b) Absorption spectrum :

This occurs due to the following law :

"The vapour of an element at a lower temperature selectively absorbs the light which it will itself emit, when it is at a higher temperature".

For example, when white light passes through a particular material, then that material will absorb some of the colours of the white light. Thus, in the spectrum produced by the transmitted light, the colours, as absorbed by the material, will be missing and their places will be occupied by dark lines or bands.

This (Dark line) can be illustrated through the solar spectrum. Here the continuous spectrum of the sun-light is crossed by a large number of dark lines (called the Fraunhofer lines), which are due to the presence of some terrestrial elements in the atmosphere of the sun.

Another example is that : when white light passes through a dilute solution of potassium permanganate, the middle region of the spectrum will be absorbed by the solution, thereby resulting in a dark-band.

Dark band spectra can also be obtained by using coloured glasses.

12.13: Dispersive power

The dispersive power of the material (of a prism) with respect to any two colours is given by the ratio of the difference between the deviations of these two colours to the deviation of the mean ray between them.

Illustration : Let us consider white light.

Let D_V = Deviation of violet ray
 D_R = Deviation of red ray
 D_Y = Deviation of mean ray (May be taken as yellow, since $\lambda_V = 4000\text{\AA}$

$$\lambda_R = 8000\text{\AA}$$

$$\lambda_Y = 6000\text{\AA}$$

Thus, by def.:

$$\text{Dispersive power of the material of the Prism } (\omega, \text{ say}) = \dots 12.12.1$$

If we take a Prism with a small angle, say A, we can use the following formula 12.6.2 to calculate deviation.

$$D = (\mu - 1)A$$

so that $D_V = (\mu_V - 1)A$

$$D_R = (\mu_R - 1)A$$

$$D_Y = (\mu_Y - 1)A$$

$$\therefore \omega = \frac{A[(\mu_V - 1) - (\mu_R - 1)]}{A(\mu_Y - 1)}$$

$$= \frac{\mu_V - \mu_R}{\mu_Y - 1} \dots 12.12.2$$

12.14: Refraction at curved surface

Refraction at a single refracting surface :

Case (a): Convex spherical surface (Real image)

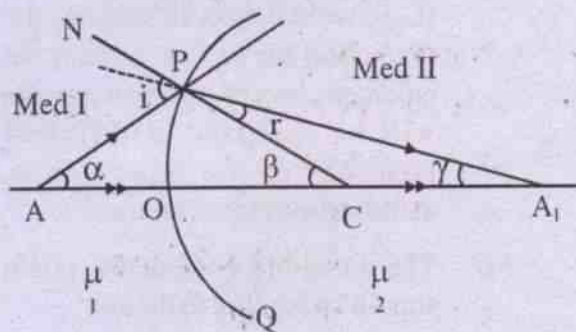

Fig.12.10 Refraction at convex spherical surface (Real image)

- POQ = Interface (A convex spherical surface), separating Medium I (say, rarer) from Medium II (say, denser)
- A = A point object on the principal axis
 AOA_1
- AP = Incident ray
- PA_1 = Refracted ray
- C = Center of curvature of the spherical surface POQ
- NPC = Normal at the point of incidence P to the surface POQ
- AO = Incident ray falling normal - Refracted undeviated along OA_1
- A_1 = Image (real) of object A
- μ_1, μ_2 = Refraction index of Med I and II respectively.

- Let $\angle PAO = \alpha$
 $\angle PCA = \beta$
 $\angle PA_1C = \gamma$
 $\angle APN = i$ (Angle of incidence)
 $\angle A_1PC = r$ (Angle of refraction)

In the triangle APC,

$$\text{Exterior } \angle APN = i = \alpha + \beta \quad \dots 12.13.1$$

In the triangle A_1PC ,

$$\text{Exterior } \angle PCA = \beta = \gamma + r \quad \dots 12.13.2$$

From eq. 12.1.7, we have

$$i\mu_1 = r\mu_2$$

which, using eqs. 12.13 (1 & 2), gives

$$(\alpha + \beta)\mu_1 = (\beta - \gamma)\mu_2$$

$$\text{or, } (\tan\alpha + \tan\beta)\mu_1 = (\tan\beta - \tan\gamma)\mu_2 \quad \dots 12.13.3$$

(since α, β and γ are small)

Let us assume further that the aperture of the surface is small, so that we can consider PO as almost a straight line and perpendicular to the principal axis.

Hence eq. 12.13.3 gives

$$\mu_1 \left(\frac{PO}{AO} + \frac{PO}{OC} \right) = \mu_2 \left(\frac{PO}{OC} - \frac{PO}{OA_1} \right)$$

$$\text{or, } \frac{\mu_1}{OA} + \frac{\mu_1}{OC} = \frac{\mu_2}{OC} - \frac{\mu_2}{OA_1}$$

$$\therefore \frac{\mu_1}{OA} + \frac{\mu_2}{OA_1} = \frac{1}{OC} (\mu_2 - \mu_1)$$

$$\text{or, } \frac{\mu_1}{-u} + \frac{\mu_2}{+v} = \frac{1}{R} (\mu_2 - \mu_1)$$

after applying sign convention

$$\therefore \frac{\mu_2}{v} - \frac{\mu_1}{u} = \frac{\mu_2 - \mu_1}{R} \quad \dots 12.13.4$$

Case (b): Convex spherical surface (virtual image)

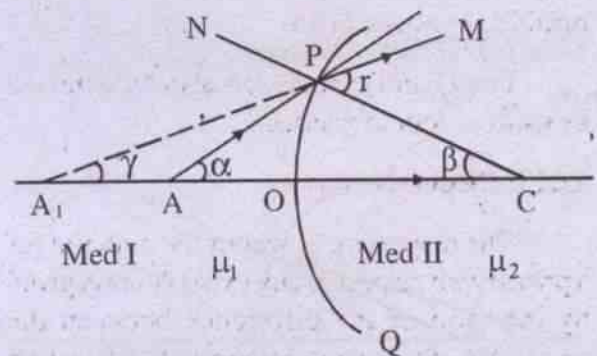

Fig. 12.11 Refraction at convex spherical surface (Virtual image)

In this case, the refracted rays PM and OC diverge, if we produce them in forward direction (i.e., Right Hand Side). Hence to get their intersection, we produce them backwards, so that they intersect at A_1 .

Thus A_1 = Image of A

In the triangle APC,

$$\text{Exterior } \angle APN = i = \alpha + \beta$$

In the triangle A_1PC

$$\text{Exterior } \angle MPC = r = \beta + \gamma$$

Substituting these values in eq. 12.1.7, we get

$$\mu_1(\alpha + \beta) = \mu_2(\gamma + \beta)$$

$$\text{or, } \mu_1(\tan\alpha + \tan\beta) = \mu_2(\tan\gamma + \tan\beta)$$

$$\text{or, } \mu_1\left(\frac{PO}{OA} + \frac{PO}{OC}\right) = \mu_2\left(\frac{PO}{OA_1} + \frac{PO}{OC}\right)$$

$$\text{or, } \frac{\mu_1}{OA} - \frac{\mu_2}{OA_1} = \frac{1}{OC}(\mu_2 - \mu_1)$$

$$\text{or, } \frac{\mu_1}{-u} - \frac{\mu_2}{-v} = \frac{1}{+R}(\mu_2 - \mu_1)$$

after applying sign-convention

$$\therefore \frac{\mu_2}{v} - \frac{\mu_1}{u} = \frac{1}{R}(\mu_2 - \mu_1) \quad \dots 12.13.5$$

Case (c): Concave surface

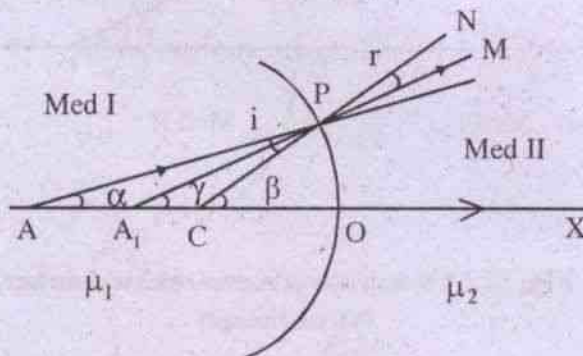

Fig. 12.12 Refraction at concave spherical surface (Virtual image)

In this case, the refracted rays PM and OX diverge in the forward direction. So we produce them backwards to get the image at the

intersection point A_1 .

In the triangle APC, external angle $\beta = \alpha + i$

$$\text{so that } i = \beta - \alpha$$

In the triangle A_1PC , external angle $\beta = \gamma + r$

$$\text{so that } r = \beta - \gamma$$

Substituting these values in the eq. $i\mu_1 = r\mu_2$, we obtain :

$$(\beta - \alpha)\mu_1 = (\beta - \gamma)\mu_2$$

$$\text{or, } (\tan\beta - \tan\alpha)\mu_1 = (\tan\beta - \tan\gamma)\mu_2$$

$$\text{or, } \left(\frac{OP}{OC} - \frac{OP}{OA}\right)\mu_1 = \left(\frac{OP}{OC} - \frac{OP}{OA_1}\right)\mu_2$$

$$\therefore \frac{\mu_2}{OA_1} - \frac{\mu_1}{OA} = \frac{\mu_2}{OC} - \frac{\mu_1}{OC}$$

$$\text{or, } \frac{\mu_2}{-v} - \frac{\mu_1}{-u} = \frac{\mu_2}{-R} - \frac{\mu_1}{-R}$$

$$\text{or, } \frac{\mu_2}{v} - \frac{\mu_1}{u} = \frac{(\mu_2 - \mu_1)}{R} \quad \dots 12.13.6$$

If we take Medium I as air, then $\mu_1 = 1$.

Substituting this value in eqs. 12.13 (4, 5 and 6), we get the general expression as

$$\frac{\mu}{v} - \frac{1}{u} = \frac{1}{R}(\mu - 1) \quad \dots 12.13.7$$

where $\mu =$ Refractive index of the Medium II.

12.15: Power: Spherical refracting surface:

Power of a spherical refracting surface

$$= \frac{\mu_2 - \mu_1}{R} \quad \dots 12.14.1$$

Sign-convention : Consider incident rays which are parallel. If these rays converge after refraction in a spherical refracting surface, then the power of this surface is +ve. However, if the rays diverge, then the surface has negative power.

12.16: Refraction through a lens bounded by air :

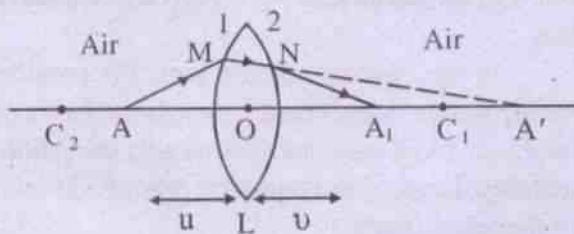

Fig. 12.13 Refraction through a thin lens

Let the lens L be thin and its material has a refractive index μ . Let its two spherical surfaces, marked 1 and 2, have centers of curvature C_1 and C_2 respectively. Let O be the center of the lens.

Radius of curvature of surface 1 = $OC_1 = r_1$

Radius of curvature of surface 2 = $OC_2 = r_2$

A = Point object

A' = Image of A due to surface 1

A₁ = Final image (i.e., image produced after refraction through both the surfaces 1 and 2)

AM = Incident ray

MN = Refracted ray

NA₁ = Emergent ray

OA = Object distance = u

OA' = (intermediate) Image distance = v'

OA₁ = Image distance = v

Using eq. 12.13.4 for refraction at surface 1, we get :

$$\frac{\mu}{v'} - \frac{1}{u} = \frac{1}{r_1}(\mu - 1) \quad \dots 12.15.1$$

For refraction at surface 2 (in which light is passing from denser to rarer medium, we get

$$\frac{1}{v} - \frac{1}{v'} = \frac{1}{r_2} - \frac{1}{\mu}$$

Multiplying by μ throughout, we obtain:

$$\frac{1}{v} - \frac{\mu}{v'} = \frac{1 - \mu}{r_2} \quad \dots 12.15.2$$

Adding eqns. 12.15 (1 & 2), we have :

$$\frac{1}{v} - \frac{1}{u} = (\mu - 1) \left(\frac{1}{r_1} - \frac{1}{r_2} \right) \quad \dots 12.15.3$$

Let us apply the above eqn. to a case, as specified below :

Suppose an object is at infinity. Then parallel rays will come out of it. After refraction, they will meet at the focal plane of the refracting body. Thus we have here :

$$u = \infty$$

$$v = f$$

When these values are substituted in 12.15.3, we get

$$\frac{1}{f} = (\mu - 1) \left(\frac{1}{r_1} - \frac{1}{r_2} \right) \quad \dots 12.15.4$$

Eq. 12.15.4 is known as the Lens Maker's formula.

Comparing eqns. 12.15 (3 & 4), we have

$$\frac{1}{f} = \frac{1}{v} - \frac{1}{u} \quad \dots 12.15.5$$

The eqn. (12.15.4) can be applied to convex and concave lenses, as follows :

(i) Convex Lens : $r_1 = +ve$

$$r_2 = -ve$$

so we get:
$$\frac{1}{f} = (\mu - 1) \left(\frac{1}{r_1} + \frac{1}{r_2} \right)$$

(ii) Concave lens : $r_1 = -ve$

$$r_2 = +ve$$

so that we get:
$$\frac{1}{f} = -(\mu - 1) \left(+\frac{1}{r_1} + \frac{1}{r_2} \right)$$

12.17: Lenses: Preliminaries

Lens:

It is a transparent refracting medium, bounded by two surfaces of regular geometrical form. The geometrical form may be spherical, plane, cylindrical on one surface. Usually the spherical form of the surfaces is used.

Classification of lenses :

There are two types (i) convex, (ii) concave.

(1) *Convex (or converging)*: They are thicker at the middle part than at the edges. Example :

- (i) Double (or Bi-) convex:
Both surfaces are convex.
- (ii) Plano convex: One surface is plane and the other one is convex.
- (iii) Concavo-convex-one surface is concave, whereas the other is convex.

(2) *Concave (or, Diverging)*: They are thinner at the middle part than at the edges.

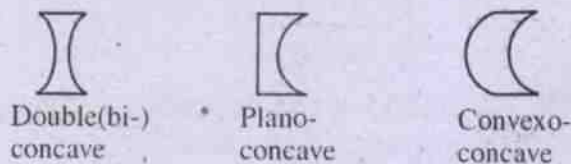

Fig. 12.15 Types of Concave Lens

To explain the optical behaviour of a lens, we may consider it as consisting of a set of truncated prisms arranged symmetrically on the opposite sides of the principal axis.

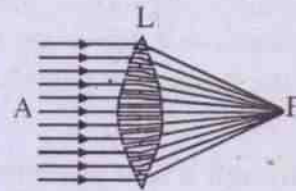

Fig. 12.16 Convex lens

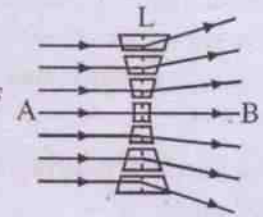

Fig.12.17 Concave lens

In the case of convex lens, the parallel incident rays, which bend towards the bases of their individual truncated prisms after refraction, actually intersect at a common point F - known as the focus (real).

In the case of concave lens, the parallel incident rays, which bend towards the base of their respective truncated prisms on refraction, do not intersect in the forward direction and, hence, they are produced backwards, so that they will appear to meet at a point, known as focus (virtual).

Optic center:

It is a point within a lens, such that when a ray passes through it, it is displaced but not deviated. However if the lens is thin, the ray passing through the optic center passes straight, i.e., without deviation or displacement.

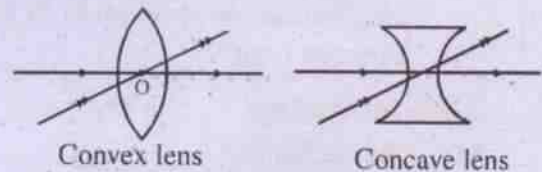

Fig.12.18 Optic center (O)

Principal axis :

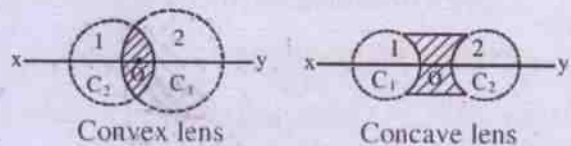

Fig 12.19

- : Principal axis (XY)
- : Principal section (shaded portion)

C_1 and C_2 are the centers of curvature of the spherical surfaces 1 and 2 of a lens respectively. A straight line passing through C_1 and C_2 is called principal axis.

Principal section :

The cut away section of a lens, as obtained by passing a plane through the principal axis is called the Principal Section.

Principal focus :

- A lens has two principal foci
- (1) First Principal Focus
 - (2) Second Principal Focus

(1) First Principal Focus :

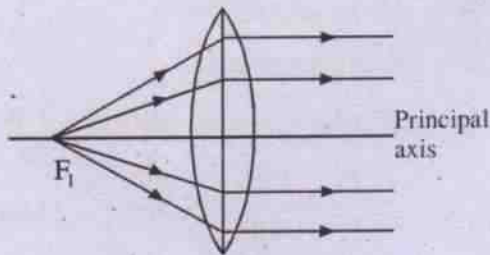

Fig. 12.20 Convex lens: First Principal Focus (Incident rays are divergent)

Consider a point on the principal axis. If the rays, starting from it, emerge parallel to the principal axis after refraction through the lens, then it is called the first principal focus of the lens.

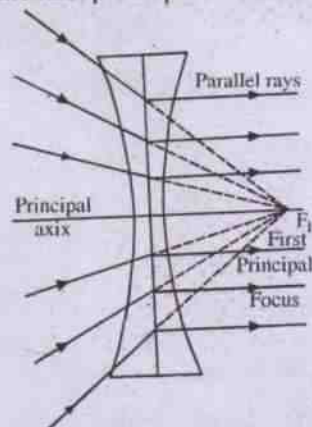

Fig. 12.21 Concave lens: First principal focus (F_1) (Incident rays are convergent)

However, in the case of a concave lens, we consider a beam of converging rays. If these rays are intercepted by a concave lens, so that the rays will be rendered parallel to the principal axis after refraction, then the point of convergence on the principal axis is called the first principal focus.

(2) Second Principal Focus :

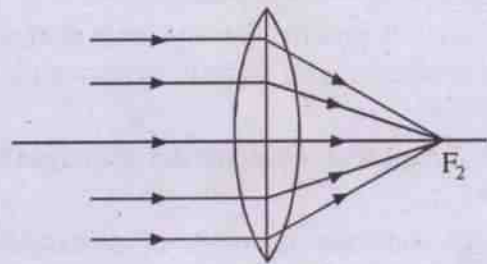

Fig. 12.22 Convex lens: Second Principal Focus (F_2) (Incident rays are parallel)

Consider rays, parallel to principal axis. After refraction, they intersect on the principal axis, giving the second principal focus - which is real.

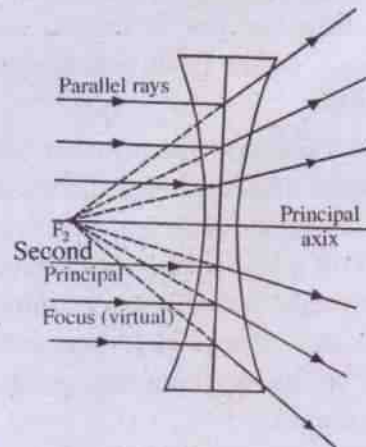

Fig. 12.23 Concave lens: Second Principal Focus (F_2) (Incident rays are parallel)

If we consider rays, parallel to principal axis, after refraction, they appear to diverge from a point, on the principal axis. This common point of divergence (F_2) is called the second principal focal point which is virtual.

Note: Usually the second principal focus is termed as the principal focus of the lens.

Focal length: The distance between the optic center and either one of the principal foci (conveniently the second principal focus) is called the focal length of a lens.

Focal plane: Any vertical plane passing through a focal point and perpendicular to the principal axis is called the focal plane.

A lens has two focal planes, corresponding to two principal foci.

Thin lens: A lens, having negligible thickness when compared with its radii of curvature, is called thin.

12.18: Graphical construction of images for lenses :

(i) To construct an image of an extended object, placed perpendicular to the principal axis, the following two rays starting from the tip of the object may be considered :

(a) One ray is taken parallel to the principal axis. After refraction, it will pass through the focus.

(b) Another ray is taken, passing through the optic center. It will pass straight even after refraction.

(ii) The intersection of the above two refracted rays will give the tip of the image. Drop a normal from this point on the principal axis to get the full image. If the refracted rays actually intersect (i.e., intersection is in the forwarded direction), the image is real. But if their intersection is obtained by producing them backwards, then the image is virtual.

12.19: Sign convention: Lenses

This is the same, as in the case of spherical mirrors.

Direction of incident ray

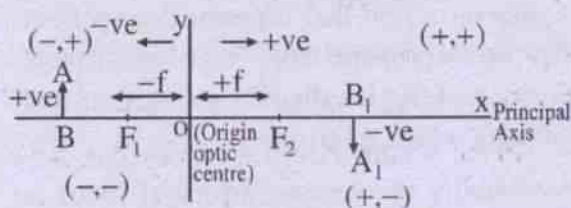

Fig. 12.24 Sign convention (Lenses)

12.20: General formula for lenses :

(a) Convex lens

Case 1: (Real image)

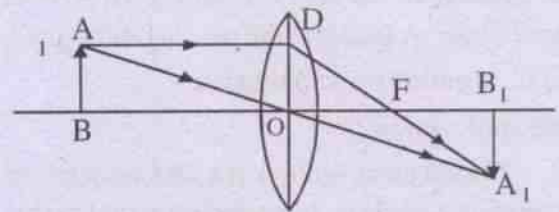

Fig. 12.25: Convex lens-Real image

AB = object

A_1B_1 = Image (obtained by following procedure in 12.17) (Image is real)

OB = Object distance = u

OB_1 = Image distance = v

OF = focal length = f

In the similar triangles ABO and A_1B_1O

$$\frac{A_1B_1}{AB} = \frac{OB_1}{OB} \quad \dots 12.19.1$$

In the similar triangles A_1B_1F and FDO :

$$\frac{A_1B_1}{OD} = \frac{FB_1}{OF}$$

$$\text{or, } \frac{A_1B_1}{AB} = \frac{FB_1}{OF} \quad \dots 12.19.2$$

(\because ADOB is a rectangle)

Comparing eqs. 12.19 (1 & 2) :

$$\frac{OB_1}{OB} = \frac{FB_1}{OF} \quad \dots 12.19.3$$

Applying sign convention :

$$OB_1 = +v$$

$$\bullet \quad OB = -u$$

$$FB_1 = OB_1 - OF$$

$$= v - f$$

$$OF = +f$$

so that eq. (12.19.3) yields :

$$\frac{v}{-u} = \frac{v-f}{f}$$

or, $vf = -uv + uf$

or, $\frac{1}{f} = \frac{1}{v} - \frac{1}{u}$...12.19.4

Case2: Convex lens (virtual image) :

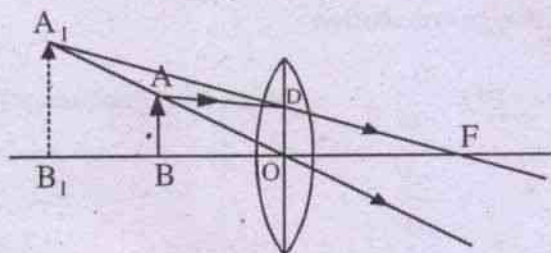

Fig. 12.26 Convex lens-virtual image

In this case, the object is placed between the first principal focus and optic center of the lens. Since the refracted rays diverge in the forward direction, their intersection is obtained by producing them backwards - resulting in a virtual image.

- AB = object
- A₁B₁ = Image (virtual, erect, magnified)
- OB = Object distance = u
- OB₁ = Image distance = v
- OF = focal length = f

In the similar triangles A₁B₁O and ABO

$$\frac{A_1B_1}{AB} = \frac{OB_1}{OB} \quad \dots 12.19.5$$

In the similar triangles A₁B₁F and ODF

$$\frac{A_1B_1}{OD} = \frac{FB_1}{OF}$$

or, $\frac{A_1B_1}{AB} = \frac{FB_1}{OF}$...12.19.6

Comparing eq. 12.19 (5 and 6)

$$\frac{OB_1}{OB} = \frac{FB_1}{OF} \quad \dots 12.19.7$$

By sign convention

$$OB = -u$$

$$OB_1 = -v$$

$$FB_1 = OB_1 + OF = -v + f$$

$$OF = +f$$

Using these values, eq. (12.19.7) gives

$$\frac{-v}{-u} = \frac{-v+f}{f}$$

or, $vf = -uv + uf$

or, $\frac{1}{f} = \frac{1}{v} - \frac{1}{u}$...12.19.8

(b) Concave lens :

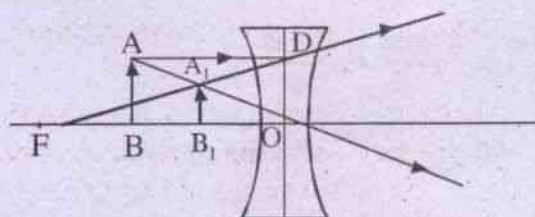

Fig. 12.27 Concave lens virtual image

A concave lens always produces virtual image. Since the two refracted rays diverge in the forward direction, we produce them backwards to get their intersection at A₁.

- AB = object
- A₁B₁ = Image (virtual, erect, magnified)
- OB = Object distance = u
- OB₁ = Image distance = v
- OF = focal length = f

In the similar triangles ABO and A₁B₁O

$$\frac{A_1B_1}{AB} = \frac{OB_1}{OB} \quad \dots 12.19.9$$

In the similar triangles FA_1B_1 and FDO

$$\frac{A_1B_1}{OD} = \frac{B_1F}{OF}$$

$$\text{or, } \frac{A_1B_1}{AB} = \frac{B_1F}{OF} \quad \dots 12.19.10$$

(\because ADOB is a rectangle)

Equating eqns. 12.19 (9 and 10) :

$$\frac{OB_1}{OB} = \frac{B_1F}{OF} \quad \dots 12.19.11$$

By sign convention

$$OB_1 = -v$$

$$OB = -u$$

$$B_1F = OF - OB_1$$

$$= -f + v$$

$$OF = -f$$

so that eq. 12.19.11 gives :

$$\frac{-v}{-u} = \frac{-f + v}{-f}$$

$$\text{or, } -fv = -uf + uv$$

$$\text{or, } \frac{1}{f} = \frac{1}{v} - \frac{1}{u} \quad \dots 12.19.12$$

From the u - v relation of the above three cases, the general formula can be written as :

$$\frac{1}{v} - \frac{1}{u} = \frac{1}{f} \quad \dots 12.19.13$$

12.21 Magnification (= m):

Unless otherwise mentioned, magnification means transverse (or, lateral) magnification. It is defined as :

Magnification =

$$m = \frac{\text{Height of the image}}{\text{Height of the object}} \quad \dots 12.20.1$$

In all the above three cases, the ray-diagrams give :

$$\frac{\text{Height of the image}}{\text{Height of the object}} = \frac{A_1B_1}{AB} = \frac{OB_1}{OB} \quad \dots 12.20.2$$

(Ref: eqns. 12.19.1, 5 and 9)

Equating 12.20 (1 and 2), we have :

$$m = \frac{OB_1}{OB} \quad \dots 12.20.3$$

With sign convention :

$$m = \frac{v}{-u} \quad (\text{convex lens-Real image})$$

$$= \frac{-v}{-u}$$

$$= \frac{v}{u} \quad (\text{Concave / convex lens}$$

Virtual image)

12.22: Nature, size, position of image :

(a) Convex lens :

(i) Object at infinity :

Let the parallel rays, coming out of the tip (A) of the object AB at infinity, make a

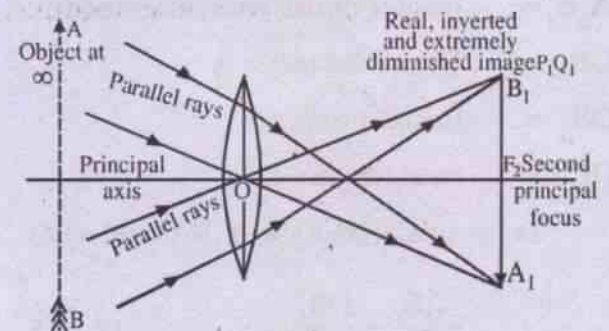

Fig. 12.28 Convex lens : Object at ∞

small angle with the principal axis of the lens. After intersection, the rays would intersect at A_1 giving the image.

The image will be real, inverted and very much diminished and found at the second focal plane.

(ii) Object between infinity and $2F_1$:

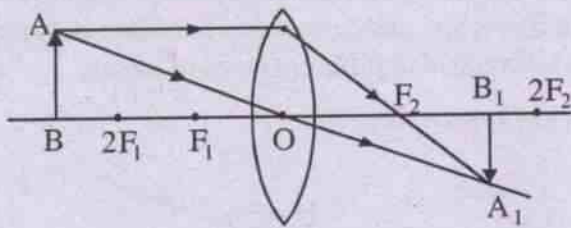

Fig. 12.29: Convex lens : Object between ∞ and $2F_1$

AB = Object

A_1B_1 = Image (Real, inverted, diminished) and located between F_2 and $2F_2$

(iii) Object at $2F_1$:

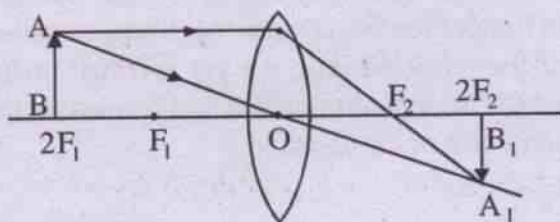

Fig. 12.30: Convex lens : Object at $2F_1$

Since the object is at $2F_1$, here, $u = -2f$ and the focal length = $+f$ with sign convention.

Substituting this value in the lens equation

$$\frac{1}{v} - \frac{1}{u} = \frac{1}{f}, \text{ we get :}$$

$$\frac{1}{v} + \frac{1}{2f} = \frac{1}{f}$$

$$\therefore \frac{1}{v} = \frac{1}{2f}$$

$$\text{or } v = +2f$$

The +ve sign shows that the image is formed at $2f$ on the other side of the lens.

Further since $u = v = 2f$, the magnification is unity, i.e., both the object and image are of the same size. Here the image is real and inverted.

(iv) Object between F_1 and $2F_1$:

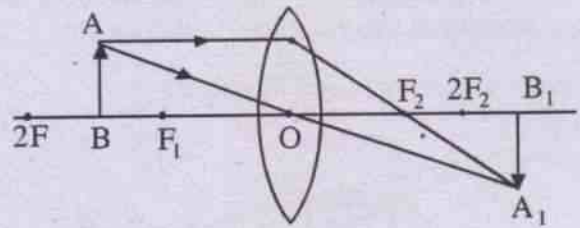

**Fig. 12.31 Convex lens
Object between F_1 and $2F_1$**

By applying the principle of reversibility of light to the case (ii) above, (i.e. object beyond $2F_1$ and hence image between F_2 and $2F_2$) we can say that the image here will be formed beyond $2F_2$ (since the object is placed between F_1 and $2F_1$). Further, the image is real, inverted and magnified.

(v) Object at F_1 :

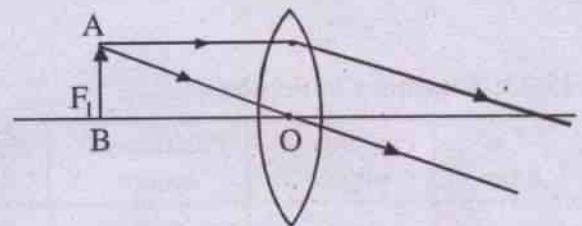

The refracted rays are parallel and will meet at ∞

Fig. 12.32

Given $u = -f$. Hence the lens-equation gives :

$$\frac{1}{v} - \frac{1}{-f} = \frac{1}{f}$$

$$\text{or, } \frac{1}{v} = 0 \text{ so that } v = \infty$$

Thus the image will be formed at ∞ . Applying the magnification formula :

$$m = \frac{v}{u}$$

$$= \frac{\infty}{u} = \text{A very large quantity}$$

Hence the image is very much magnified, real and inverted. This property is used in the collimator of spectrometer, telescope etc.

(vi) Object between F_1 and O :

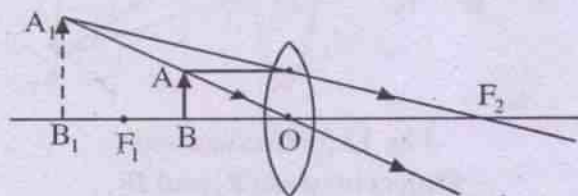

Convex lens : object between F_1 and optic centre

Fig. 12.33

As seen from the ray diagram, the refracted rays diverge on refraction in the forward direction. So their intersection is obtained backwards at A_1 . The image (A_1B_1) is virtual, magnified, erect and formed on the same side as object.

This property is made use of in the construction of magnifying glasses, eyepiece of microscope and telescope. This also helps in distinguishing different types of lenses.

(b) Concave lens :

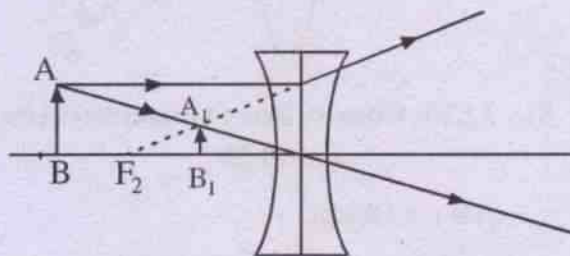

Convex lens : object image diagram

Fig. 12.34

The object may be placed at any position in front of the lens. Due to the divergent nature of the refracted rays, we get a virtual image which is erect, diminished and formed on the same side of the object.

12.23: Summary of results :

Lens	Position of object	Position of image	Nature of image	Size of image	Ref Fig. No.	Remarks
Convex	At ∞	At F_2	Real & Inverted	Diminished	12.28	In case of real image, as the object moves from ∞ to F_1 , the image moves from F_2 to ∞ - growing in size.
	Between ∞ and $2F_1$	Between F_2 and $2F_2$	- do -	- do -	12.29	
	At $2F_1$	At $2F_2$	- do -	Same size	12.30	
	Between $2F_1$ and F_1	Between $2F_2$ and ∞	- do -	Enlarged	12.31	
	At F_1	At ∞	- do -	- do -	12.32	
	Between F_1 and optic center	Same side as F_1 and beyond F_1	virtual, erect	- do -	12.33	
Concave	At ∞	At F_2	Virtual, erect	Diminished	12.23	Image is always virtual, erect and diminished
	Any other position	Between F_2 and optic center	- do -	- do -	12.34	

12.24: Power of lens (P)

Power is defined as :

$$P = \frac{1}{f} \quad \dots 12.23.1$$

where f = focal length of the lens

Power for convex lens is taken as +ve and for concave lens is taken as -ve.

12.25 : Dioptré :

The unit of power is dioptré.

To get the power of a lens in dioptré, we express its focal length in meter. Then its reciprocal will give its power in dioptré.

Example : Suppose we have a convex lens of focal length 20 cm.

$$\text{Then } P \text{ (in dioptré)} = \frac{1}{(20/100)} = +5 \text{ dioptré}$$

12.26: Power of two lenses in contact :

Lenses in contact : power

Fig. 12.35

L_1 and L_2 are two lenses in contact. Let focal length of L_1 and L_2 be f_1 and f_2 respectively. Then their combined focal length (F) is given by the formula :

$$\frac{1}{F} = \frac{1}{f_1} + \frac{1}{f_2} \quad \dots 12.25.1$$

Using the formula for power, (12.25.1) gives :

$$P = P_1 + P_2 \quad 12.25.2$$

where P = power of the combination

P_1 = power of the 1st lens

P_2 = power of the 2nd lens

12.27: Identification of lenses :

The lenses can be identified by testing them optically as follows :

Look at a nearby object through the lens, to be identified. If the image is enlarged and erect, the lens under question is convex. However, if the image appears diminished and erect, the lens is concave.

12.28 Scattering of Light:

When a beam of light falls on an irregular surface or passes through a gas, a part of it appears in directions other than the incident direction. This phenomenon is called scattering of light. The basic process in scattering is absorption of light by the molecules of the medium followed by its radiation in different directions.

In absorption the light energy is converted into internal energy of the medium, whereas in scattering, the light energy is radiated in other directions.

A. Rayleigh Scattering:

Rayleigh scattering is the (dominantly) elastic scattering of light or electromagnetic radiation (since the photon energy of the scattering photons is not changed) by particles much smaller than the wavelength of the radiation.

Rayleigh scattering does not change the state of material; hence it is a parametric process. The particles may be individual atoms or molecules. It can occur when light travels through transparent solids and liquids, but is most prominently seen in gases.

Rayleigh scattering results from the electric polarizability of the particles. The oscillating electric field of a light wave acts on the charges within the particles, causing them to move at the same frequency. The particle therefore behaves like a small radiating dipole, whose radiation we see as scattered light.

Rayleigh scattering applies to particles that are small with respect to wavelength of light and that are optically "soft" (i.e. with a refractive index close to 1). The size of the scattering particles is often parameterized by the factor

$$x = \frac{2\pi r}{\lambda}$$

where 'r' is its characteristic length (radius) and ' λ ' is the wavelength of light. Rayleigh scattering applies to the case when the scattering particles is very small (i.e. $x \ll 1$, with a particle size $< \frac{1}{10}$ of λ) and the whole surface re-radiates with the same phase.

Because the particles are randomly positioned, the scattered light arrives at a particular point with a random collection of phases; it is incoherent and the resulting intensity is just the sum of the squares of the amplitudes from each particle and is therefore proportional to the inverse fourth power of the wavelength and sixth power of its size. To be more specific, the intensity I of light scattered by any one of the small particles (assumed to be small spheres) of diameter 'd' and refractive index μ , from a beam of unpolarized light of wavelength λ , and intensity I_0 is given as

$$I = I_0 \frac{1 + \cos^2 \theta}{2R^2} \left(\frac{2\pi}{\lambda} \right)^4 \left(\frac{\mu^2 - 1}{\mu^2 + 1} \right)^2 \left(\frac{d}{2} \right)^6 \quad \text{----(12.28.2)}$$

Where R is the distance of the particle and θ is the scattering angle. Averaging over all angles gives the Rayleigh scattering cross-section as

$$\sigma_s = \frac{2\pi^5 d^6}{3 \lambda^4} \left(\frac{\mu^2 - 1}{\mu^2 + 1} \right)^2 = 5.1 \times 10^{-31} m^2$$

$$\text{for } \lambda = 532 \text{ nm} = 532 \times 10^9 \text{ m} \quad \text{----(12.28.3)}$$

Fraction of light scattered by a group of N particles is

$$I = \sigma_s N$$

Equation 12.28.2 can re-written in terms of individual molecules by expressing the dependence of refractive index (μ) as molecular polarizability α , proportional to dipole moment induced by the electric field of light as given below.

$$I = I_0 \frac{8\pi^4 N \alpha^2}{\lambda^4 R^2} (1 + \cos^2 \theta) \quad \text{----(12.28.4)}$$

(i) Blue colour of the Sky:

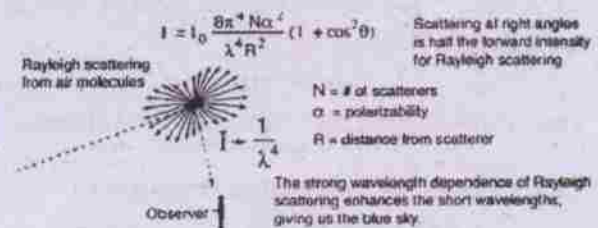

Fig. 12.36

As shown above this strong wavelength dependence of Rayleigh scattering means that shorter (blue) wavelengths are scattered more strongly than longer (red) wavelengths by the molecules of gas and other small particles in the atmosphere. This results in the indirect blue light coming from all regions of the sky.

However, the Sun, like any other star, has its own spectrum and so I_0 in the scattering formula (12.28.4) is not constant but falls away in the violet. Further the Oxygen in earth's atmosphere absorbs wavelengths at the edge of U-V region of the spectrum. The resulting colour, which appears like pale blue, actually is a mixture of all the scattered colours, mainly blue and green. Conversely, glancing towards the Sun, the colours that are scattered away the longer wavelengths such as red and yellow light are directly visible, giving the Sun itself a slightly

yellowish hue. Viewed from space, however, the sky is black and the Sun is white.

(iii) Reddish appearance of Sun at sunset and sunrise:

When the Sun is near horizon light from Sun passes through a greater distance in earth's atmosphere than the distance it passes when the Sun is overhead. The correspondingly greater scattering of short wavelengths, removing virtually all the blue light from the direct path to the observer, accounts for the reddish appearance of the Sun at sunrise and sunset.

B. Mie Scattering:

For the sake of completion we give below a brief note about Mie scattering.

Mie Scattering

The scattering from molecules and very tiny particles ($\ll 1/10$ wavelength) is predominantly Rayleigh scattering. For particle sizes larger than a wavelength Mie scattering predominates. This scattering produces a pattern like an antenna lobe, with a sharper and more intense forward lobe for larger particles.



Fig. 12.37

Mie scattering is not strongly wavelength dependent and produces the almost white glare around the Sun when a lot of particulate material is present in the air. It also gives us the white light from mist and fog.

Ex. 2.1 : Calculate the refractive index of cedar wood oil relative to air when its critical angle is $41^\circ 16'$.

Soln.

$$\text{Rarer } \mu_{\text{Denser}} = \frac{1}{\sin C}$$

$$\therefore \text{air } \mu_{\text{cedar wood oil}} = \frac{1}{\sin 41^\circ 16'}$$

$$= \frac{1}{0.66} = 1.51$$

Ex. 2.2: The critical angle for refraction from glass to air is 42° and that from water to air is 48° . Find the critical angle for refraction from glass to water.

Soln.

$${}_a\mu_g = \frac{1}{\sin 42^\circ} = \frac{1}{0.67} = 1.49$$

$${}_a\mu_w = \frac{1}{\sin 48^\circ} = \frac{1}{0.74} = 1.35$$

But ${}_w\mu_g = {}_w\mu_a \times {}_a\mu_g$

$$= {}_a\mu_g \cdot {}_a\mu_w$$

$$= \frac{1.49}{1.35}$$

$$= 1.10$$

$$\therefore {}_w\mu_g = \frac{1}{\sin C} = 1.1$$

or $\sin C = \frac{1}{1.1} = 0.91$

$$\therefore C \approx 65^\circ$$

Ex.2.3: A ray of light in air makes an angle of incidence 45° at the surface of a sheet of ice. The ray is refracted within the ice at an angle of 30° . What is the critical angle of ice ?

Soln.

By Snell's Law :

$${}_a\mu_{\text{ice}} = \frac{\sin 45^\circ}{\sin 30^\circ}$$

$$= \frac{0.70}{0.50} = 1.4$$

From critical angle eqn :

$$\begin{aligned} {}_a\mu_{\text{ice}} &= \frac{1}{\sin c} \\ &= 1.4 \end{aligned}$$

$$\therefore \sin C = \frac{1}{1.4} = 0.71$$

$$\text{or, } c \approx 45^\circ.$$

Ex. 2.4 A glass prism of angle $59^\circ 52'$ has an angle of minimum deviation of $40^\circ 30'$ for a given colour of light. Calculate the refractive index of glass for that colour of light.

Soln.

$$\begin{aligned} {}_a\mu_g &= \frac{\sin \frac{A + D_m}{2}}{\sin A/2} \\ &= \frac{\sin \left(\frac{59^\circ 52' + 40^\circ 30'}{2} \right)}{\sin(59^\circ 52'/2)} \\ &= \frac{\sin 50^\circ 11'}{\sin 29^\circ 56'} \\ &= 1.539 \end{aligned}$$

Ex. 2.5: Calculate the angle of emergence i and the deviation when light is incident at 90° on the face of a glass prism of refractive index 1.5 and angle of prism 60° .

Soln.

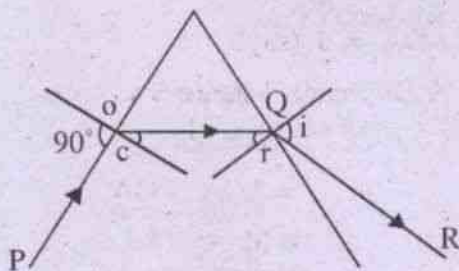

Fig. 12.36

PO = incident ray

Angle of incidence = 90°

Angle of refraction at O (Point of incidence) = Critical angle (By definition)

From the critical angle formula:

$${}_a\mu_g = \frac{1}{\sin C}$$

$$\therefore \sin C = \frac{1}{{}_a\mu_g} = \frac{1}{1.5}$$

$$\text{or, } C = 41.8^\circ$$

Further, we know $A = r' + r$

= (sum of the two angles of refraction)

In this case, $60^\circ = 41.8^\circ + r$

$$\therefore r = 18.2^\circ$$

Applying Snell's law to the point Q,

$$1.5 = \frac{\sin i}{\sin 18.2}$$

$$\therefore i = 27.9^\circ$$

Further total angle of deviation =

Deviation at O + Deviation at Q

$$= (90 - C) + (i - r)$$

$$= (90 - 41.8) + (27.9 - 18.2)$$

$$= 57.9^\circ$$

Ex. 2.6: Find the dispersive power of flint glass. (Given: $\mu_V = 1.632$, $\mu_Y = 1.620$, $\mu_R = 1.613$)

Soln.

We use the formula:

$$\omega = \text{Dispersive power} = \frac{\mu_V - \mu_R}{\mu_Y - 1}$$

$$= \frac{1.632 - 1.613}{1.620 - 1}$$

$$= 0.03064$$

Ex. 2.7: An object is placed 12 cm in front of a convex lens of focal length 18 cm. Find the position and nature of the image.

Soln.

$$u = -12 \text{ cm}$$

$$f = +18 \text{ cm}$$

(\because the lens is convex, f is taken +ve)

Using the relation

$$\frac{1}{v} - \frac{1}{u} = \frac{1}{f}$$

$$\frac{1}{v} + \frac{1}{12} = \frac{1}{18}$$

$$\begin{aligned} \therefore \frac{1}{v} &= \frac{1}{18} - \frac{1}{12} \\ &= \frac{-1}{36} \end{aligned}$$

$$\therefore v = -36 \text{ cm}$$

The -ve sign shows that the object and image are in the same side of the lens. The image is virtual, erect and magnified.

Ex. 2.8: An object is placed 20 cm in front of a concave lens of focal length 10 cm. Find the nature and position and the magnification of the image.

Soln.

$$f = -10 \text{ cm}$$

(\because the lens is concave, f is taken -ve)

$$u = -20 \text{ cm}$$

Using the u - v relation

$$\frac{1}{v} - \frac{1}{u} = \frac{1}{f}$$

$$\text{We have } \frac{1}{v} + \frac{1}{20} = -\frac{1}{10}$$

$$\begin{aligned} \text{or, } \frac{1}{v} &= -\frac{1}{10} - \frac{1}{20} \\ &= \frac{-3}{20} \end{aligned}$$

$$\therefore v = -\frac{20}{3} \text{ cm}$$

The -ve sign shows that the object and image are in the same side of the lens. The image is virtual and erect.

$$\begin{aligned} \text{Magnification} &= \frac{v}{u} \\ &= \frac{20/3}{20} \\ &= \frac{1}{3} \end{aligned}$$

Hence the image is one-third diminished.

Ex. 2.9: Find the least possible distance between object and real image with converging lens.

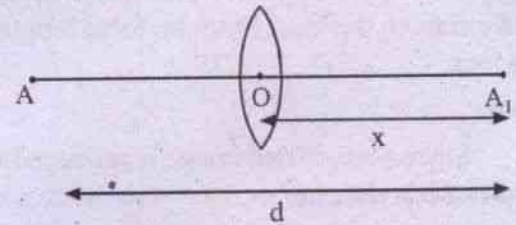

Minimum distance between object and image

Fig. 12.37

A = point object on principal axis

A_1 = image

$AOA_1 = d$ (say)

A_1O = image distance = x (say)

Object distance = AO

$$= AOA_1 - OA_1$$

$$= (d - x)$$

Let focal length of lens = f .

Applying sign convention,

$$OA = u = -(d - x)$$

$$OA_1 = v = +x$$

$$\text{focal length} = +f$$

$$\text{Using } \frac{1}{v} - \frac{1}{u} = \frac{1}{f},$$

$$\frac{1}{+x} - \frac{1}{-(d-x)} = +\frac{1}{f}$$

$$\text{or, } \frac{1}{x} + \frac{1}{d-x} = \frac{1}{f}$$

$$\therefore [(d-x) + x]f = x(d-x)$$

$$\text{or, } x^2 - dx + df = 0$$

For a real image, the roots of this quadratic equation for x must be real roots (i.e., in the quadratic eqn. $ax^2 + bx - c = 0$, $b^2 - 4ac > 0$).

$$\text{In this case, } (d^2 - 4 \times 1 \times df) > 0$$

$$\text{i.e. } d^2 - 4df > 0$$

$$\text{or, } d(d - 4f) > 0$$

$$\text{or, } d > 4f$$

Ex. 2.10: A lens projects an image 30 times as large as the object, which is placed at a distance of 8 cm from the lens. Find the focal length of the lens.

Soln.

Since a magnified image is produced, the lens is a convex one.

$$u = -8 \text{ cm}$$

$$M = \frac{v}{u} = 30$$

$$\therefore v = -240 \text{ cm (for the image to be erect)}$$

$$\text{Using } \frac{1}{v} - \frac{1}{u} = \frac{1}{f}$$

$$\frac{1}{-240} + \frac{1}{8} = \frac{1}{f}$$

$$\text{or, } \frac{1}{f} = \frac{-1+30}{240} = \frac{29}{240}$$

$$\therefore f = 8.27 \text{ cm.}$$

Ex. 2.11: The radius of curvature of each surface of a double convex lens is 20 cm and the refractive index of the medium of the lens is 1.5. Find the focal length of the lens.

Soln.

$$\text{Given } r_1 = +20 \text{ cm}$$

$$r_2 = -20 \text{ cm}$$

$$\mu = 1.5$$

Substituting these values in the eqn.

$$\frac{1}{f} = (\mu - 1) \left(\frac{1}{r_1} - \frac{1}{r_2} \right), \text{ we have}$$

$$\frac{1}{f} = (.5) \left(\frac{1}{20} + \frac{1}{20} \right)$$

$$\therefore f = 20 \text{ cm.}$$

Ex. 2.12: A double convex lens is made of glass of refractive index 1.65 and the radii of its surfaces 50 cm and 75 cm (a) Compute its focal length (b) If the flatter surface of the lens is concave, recompute its focal length.

Soln.

$$\text{Use the relation } \frac{1}{f} = (\mu - 1) \left(\frac{1}{r_1} - \frac{1}{r_2} \right)$$

$$(a) \text{ Given } \mu = 1.65$$

$$r_1 = +50 \text{ cm}$$

$$r_2 = -75 \text{ cm}$$

$$\therefore \frac{1}{f} = (1.65 - 1) \left(+\frac{1}{50} + \frac{1}{75} \right)$$

$$= .65 \times \frac{5}{150}$$

$$= 46.15 \text{ cm}$$

$$(b) r_1 = 50 \text{ cm}$$

r_2 , having larger radius, is flatter

By the question $r_2 = +75$ cm (being concave)

$$\begin{aligned}\therefore \frac{1}{f} &= .65 \left(\frac{1}{50} - \frac{1}{75} \right) \\ &= \frac{.65}{150} \\ \therefore f &= 230.7 \text{ cm}\end{aligned}$$

Ex. 2.13: A glass lens has focal length 5 cm in air. What will be its focal length in water?

(Refractive index of glass and water is 1.51 and 1.33 respectively)

Soln.

$$\begin{aligned}\frac{1}{f} &= (\mu - 1) \left(\frac{1}{r_1} - \frac{1}{r_2} \right) \\ \therefore \frac{1}{5} &= (1.51 - 1) \left(\frac{1}{r_1} - \frac{1}{r_2} \right) \\ \text{or, } \left(\frac{1}{r_1} - \frac{1}{r_2} \right) &= \frac{1}{5 \times .51} \quad \dots(1)\end{aligned}$$

When a lens of Refractive index μ_g is placed in a liquid of Refractive index μ_l , the focal length of the lens is given by :

$$\begin{aligned}\frac{1}{f} &= \left(\frac{\mu_g}{\mu_l} - 1 \right) \left(\frac{1}{r_1} - \frac{1}{r_2} \right) \\ \therefore \frac{1}{f} &= \left(\frac{1.51}{1.33} - 1 \right) \left(\frac{1}{5 \times .51} \right) \\ &= 18.84 \text{ cm}\end{aligned}$$

Ex. 2.14: A convex lens of focal length 40 cm is in contact with a concave lens of focal length 25 cm. Find the power of the combination.

Soln.

Power of the lens in Diopetre

$$= \frac{1}{\text{focal length (in met)}}$$

$$\therefore P_1 = \frac{1}{+0.4} \text{ D} \quad (\text{for convex lens})$$

$$\text{and } P_2 = \frac{1}{-0.25} \text{ D} \quad (\text{for concave lens})$$

$$\therefore P = P_1 + P_2$$

$$= \frac{1}{.4} - \frac{1}{.25}$$

$$= 2.5 - 4$$

$$= -1.5 \text{ D}$$

Ex. 2.15: The plane faces of the identical plano-convex lenses, each having focal length of 40 cm are placed against each other to form a usual convex lens. Find the distance from this lens at which an object must be placed to obtain a real, inverted image with magnification one.

Soln.

$$\frac{1}{F} = \frac{1}{f_1} + \frac{1}{f_2}$$

$$= \frac{1}{40} + \frac{1}{40}$$

$$\therefore F = \text{focal length of the combination}$$

$$= 20 \text{ cm}$$

We know, for a convex lens, the magnification is unity when the object is placed at $2F$.

\therefore The distance at which an object is placed for unity magnification $= 2F = 40$ cm.

SUMMARY

1. Laws of refraction :

- (i) The incident ray, the refracted and the normal at the point of incidence to the surface, separating the two media, lie in one plane.
- (ii) Snell's law : For any two media, the ratio of the sine of the angle of incidence to the sine of the angle of refraction is a constant for a light beam of a particular colour (i.e., wave length).

$$\frac{\sin i}{\sin r} = \mu_2 = \frac{\mu_2}{\mu_1} = \text{constant}$$

where i = Angle of incidence

r = Angle of refraction

μ_1, μ_2 are the absolute refractive indices of medium I and II respectively.

2. $\mu_1 \sin i = \mu_2 \sin r$

3. $\mu_{\text{medium}} = \frac{\text{Velocity of light in vacuum}}{\text{Velocity of light in medium}}$

4. Refraction through a number of medium (say, air, water, glass) :

$${}_a\mu_w \times {}_w\mu_g \times {}_g\mu_a = 1$$

- 5.(i) When light travels from vacuum to a medium, then μ is known as absolute refractive index of the medium.
- (ii) When light travels from air to a medium, then μ is known as the refractive index of the medium.
- (iii) μ depends on the pair of the media, colour of light and temperature of the media.
- (iv) As temperature of the medium increases, refractive index decreases.
- (v) μ is inversely proportional to wave length approximately.

$$\mu \propto \frac{1}{\lambda}$$

Thus $\mu_{\text{violet}} > \mu_{\text{red}}$

- (vi) The angle of deviation in refraction = D (say) = $(i - r)$

where i = Angle of incidence

r = Angle of refraction.

- (vii) Refractive Index = $\mu = \frac{\text{Real depth}}{\text{Apparent depth}}$

6. Critical angle and total internal reflection:

- (a) Let a ray travel from denser to rarer medium. The angle of incidence, for which the angle of refraction is 90° , is called the critical angle (C).

$$\sin C = \frac{\mu_1}{\mu_2} = \mu_2$$

$$\mu_{\text{Rarer}} \mu_{\text{Denser}} = \frac{1}{\sin C}$$

- (b) When angle of incidence (i) of a ray, travelling from denser to rarer medium, is greater than critical angle (C), no refraction occurs. The incident ray is reflected back to the same medium. This phenomenon is called the total internal reflection.

- (i) If $i < C$, the ray undergoes refraction
- (ii) If $i > C$, the ray undergoes total internal reflection

- (c) Critical angle depends on the two media

$$\sin C = \frac{\text{Refractive Index of the rarer medium}}{\text{Refractive Index of the denser medium}}$$

$$\text{For air or vacuum, } \mu = \frac{1}{\sin C}$$

- (d) C depends on the pair of the media, colour of light and temperature of the media.
- (e) As temperature increases, C also

increases.

$$(f) \quad C \propto \lambda$$

$$\therefore C_{\text{Red}} > C_{\text{violet}}$$

7. Prism:

(i) Angle between incident ray and emergent ray is called the angle of deviation (D).

(ii) Angle of deviation = $D = i + i' - A$

where i and i' are the angles of incidence at the two faces

A = Angle of the prism.

(iii) When the ray passes through the prism symmetrically (ie, angle of incidence = angle of emergence), the deviation of the ray is minimum (D_m). At the D_m position:

$$\text{Angle of incidence} = \frac{A + D_m}{2}$$

$$\text{Angle of refraction} = A / 2$$

$$(iv) \quad \mu = \frac{\sin \frac{A + D_m}{2}}{\sin A / 2}$$

(v) For a thin Prism :

$$D = \text{Angle of Deviation} = A (\mu - 1)$$

(vi) The refracted ray inside a prism bends towards the base.

(vii) At D_m position, the refracted ray inside the Prism is parallel to the base of the Prism.

$$(viii) \quad D_{\text{violet}} > D_{\text{Red}}$$

8. Dispersion :

(a) When a ray of white (Polychromatic) light passes through a Prism, it is split into rays of constituent colours (or, wave lengths).

This phenomenon is called dispersion of light.

(b) The display of colours is known as the spectrum. Strictly speaking, spectrum is the orderly coloured pattern, obtained in the screen, after dispersion of light.

(c) In pure spectrum, there is no overlapping of colours.

(d) The angle between two emergent rays of different colours is known as angular dispersion for these colours.

Angular dispersion for violet and red = $D_v - D_R$.

(e) Dispersive power (ω) of the material of the Prism is the ratio of the angular dispersion between two colours to the deviation of the mean ray, produced by the prism, for those colours.

$$\omega = \frac{D_v - D_R}{D_y}$$

$$(f) \quad \omega = \frac{\mu_v - \mu_R}{\mu_y - 1} = \frac{d\mu}{\mu - 1}$$

9. Réfraction at curved surface :

(a) When light is passing from Medium I to Medium II,

$$\frac{\mu_2}{v} - \frac{\mu_1}{u} = \frac{\mu_2 - \mu_1}{R}$$

where R = Radius of curvature of the curved surface

$$\frac{1}{v} - \frac{1}{u} = \frac{1}{R} (\mu_2 - 1)$$

where ${}_1\mu_2$ = Refractive index of the second medium with respect to the first medium.

- (b) For refraction through a lens, bounded by air,

$$\frac{1}{f} = (\mu - 1) \left(\frac{1}{r_1} - \frac{1}{r_2} \right)$$

(Lens Maker's formula)

- (c) Lens is situated in a liquid.

When a lens of refractive index μ_g is placed in a liquid of refractive index μ_l ; the focal length of the lens is given by :

$$\frac{1}{f} = \left(\frac{\mu_g}{\mu_l} - 1 \right) \left(\frac{1}{r_1} - \frac{1}{r_2} \right)$$

- (d) For a thin lens :

$$\frac{1}{f} = \frac{1}{v} - \frac{1}{u}$$

- (e) Magnification = $\frac{\text{size of the image}}{\text{size of the object}}$

$$= \left| \frac{v}{u} \right|$$

- (f) Power of a lens :

The reciprocal of the focal length (expressed in meters) of a lens is called its power (in dioptries).

$$P \text{ (in dioptries)} = \frac{1}{\text{focal length (in meters)}}$$

- (g) Equivalent focal length and power of two lenses

- (i) When in contact :

The equivalent focal length F of two lenses in contact with focal length f_1

and f_2 is given by

$$\frac{1}{F} = \frac{1}{f_1} + \frac{1}{f_2}$$

$$\therefore P = P_1 + P_2$$

- (ii) Lenses separated by a distance 'd':

$$\frac{1}{F} = \frac{1}{f_1} + \frac{1}{f_2} - \frac{d}{f_1 f_2}$$

$$\therefore P = P_1 + P_2 - d P_1 P_2$$

- (h) Air bubble in water behaves like a divergent lens.

- (i) When a lens is placed in a medium, for which μ is less than that of the lens, its focal length increases. The nature of the lens remains unchanged.

- (j) When a lens is placed in a medium for which μ is equal to that of the lens, the focal length of the lens becomes infinity and power becomes zero. The lens behaves like a plane glass plate.

- (k) When a lens is placed in a medium for which μ is greater than that of the lens, the nature of the lens changes.

- (l) When a convex lens and concave lens of equal focal length are combined, the combined focal length becomes infinity and hence power zero. This acts like a glass slab.

- (m) When a lens of focal length f is cut into two equal halves, perpendicular to the principal axis, then each part of the lens has a focal length $2f$.

- (n) When a lens of focal length f is cut into two equal halves, parallel to the principal axis, then each part has a focal length f . However the intensity of the image decreases.

MODEL QUESTIONS

A. Multiple Choice Type Questions :

1. When light passes from one medium to another, the characteristic, that remains constant is
 - a) velocity
 - b) wavelength
 - c) Amplitude
 - d) Frequency
2. One cannot see through fog, because
 - a) fog absorbs light
 - b) light is scattered by the droplets in fog.
 - c) light suffers total reflection at the droplets in the fog.
 - d) the refractive index of fog is infinity
3. A ray of light falls on a transparent glass plate. Part of it is reflected and part is refracted. The reflected and refracted rays can be perpendicular to each other for
 - a) no angle of incidence
 - b) angle of incidence equal to 90°
 - c) more than one angle of incidence
 - d) only one angle of incidence
4. The refractive index of glass is 1.5. The velocity of light in glass is
 - a) 3×10^{10} cm/sec
 - b) 4.5×10^{10} cm/sec
 - c) 2×10^{10} cm/sec
 - d) 10^{10} cm/sec
5. When a monochromatic ray of light travels from a medium of refractive index n_1 to a medium of refractive index n_2 ($n_2 > n_1$), its
 - a) speed increases by a factor n_2/n_1
 - b) speed decreases by a factor n_2/n_1
 - c) frequency decreases by a factor n_2/n_1
 - d) wavelength increases by a factor n_2/n_1
6. Light starting from a medium of refractive index μ undergoes refraction into a medium of index μ' . If i and r stand for angle of incidence and angle of refraction respectively
 - a) $\frac{\sin i}{\sin r} = \frac{\mu}{\mu'}$
 - b) $\frac{\sin i}{\sin r} = \frac{\mu'}{\mu}$
 - c) $\frac{\cos i}{\cos r} = \frac{\mu'}{\mu}$
 - d) $\frac{\sin i}{\sin r} = \frac{1}{\mu\mu'}$
7. The critical angle for total internal reflection of light going from medium I to medium II is given by the relation $\tan i_c = 5/7$. The refractive index of the medium I with respect to medium II is
 - a) 1.4
 - b) 1.6
 - c) $\sqrt{74}/5$
 - d) $5/\sqrt{74}$
8. If there is no atmosphere, then the length of the day on the earth will
 - a) decrease
 - b) increase
 - c) remain the same
 - d) depend upon the weather
9. The phenomenon of dispersion arises because of
 - a) the decomposition of white light beam by a prism

- b) the refraction of light
 c) the refractive index of the prism material.
 d) the corpuscular nature of light
10. It is possible to observe total internal reflection, when a ray travels from
 a) air into water
 b) air into glass
 c) water into glass
 d) glass into water
11. The refractive index of diamond is 2.0. Velocity of light in diamond in cm per second is approximately
 a) 6×10^{10} b) 3.0×10^{10}
 c) 2×10^{10} d) 1.5×10^{10}
12. Critical angle of light passing from glass to air is minimum for
 a) red b) green
 c) yellow d) violet
13. An equilateral triangular prism is made of glass $\mu = 1.5$. A ray of light is incident normally on one of the faces. The angle between the incident and emergent ray is
 a) 60° b) 90°
 c) 120° d) 180°
14. An equilateral prism is made of a material of refractive index $\sqrt{3}$. The angle of minimum deviation for the prism is
 a) 30° b) 45°
 c) 60° d) 90°
15. The radii of curvature of two faces of a lens are 20 cm and 30 cm and the refractive index of the material of the lens is 1.5. If the lens is concavo-convex then the focal length of the lens is
 a) 24 cm b) 10 cm
 c) 15 cm d) 120 cm
16. The minimum distance between the object and its real image formed by a convex lens is
 a) 1.5 f b) 2 f
 c) 2.5 f d) 4 f
17. A lens of power +2 dioptres is placed in contact with a lens of power -1 dioptre. The combination will behave like
 a) a divergent lens of focal length 50cm
 b) convergent lens of focal length 50cm
 c) a divergent lens of focal length 100cm
 d) a convergent lens of focal length 100cm
18. An equiconvex lens is made from glass of refractive index 1.5. If the radius of each surface is changed from 5 cm to 6cm, then the power
 a) remains unchanged
 b) increases by 3.33 dioptre approx
 c) decreases by 3.33 dioptre approx
 d) decreases by 5.5 dioptre approx
19. A lens forms a virtual image 4cm away from it when an object is placed 10cm away from it. The lens is of focal length
 a) concave, 6.67 cm
 b) concave, 2.86 cm
 c) convex, 2.86 cm
 d) may be concave or convex, 6.67cm
20. The focal length of a lens depends on
 a) radii of curvature of its surfaces only
 b) refractive index of its material only
 c) refractive index of the medium surrounding the lens only
 d) All the above factors.

21. A virtual image twice as big as the object is formed by a convex lens when the object is 10 cm away from it. A real image twice as big as the object will be formed when it is placed at a distance from the lens
- a) 40 cm b) 30 cm
c) 20 cm d) 15 cm
22. The graph drawn with object distance along abscissa and image (real) distance as ordinate for a convex lens is
- a) a straight line
b) a circle
c) a parabola
d) a rectangular hyperbola
23. The curved face of a plano-convex lens has a radius of curvature of 250 mm. The refractive index of the lens material is 1.5. The power of the lens is
- a) 0.2 D b) - 0.2 D
c) + 2 D d) - 2 D
24. An object gets closer to the focal point of a converging lens from infinity. Its image
- a) becomes smaller
b) remains of the same size
c) gets farther from the lens
d) gets closer to the lens
25. The image of an object formed by a device is always virtual and small. The device may be
- a) convex lens b) concave mirror
c) a glass plate d) concave lens
26. The linear magnification of an image is m . The magnification for area will be
- a) m b) m^2
c) $m^{1/2}$ d) m^4
27. A concave lens of focal length 20 cm produces an image half in size of the real object. The distance of the real object is
- a) 20 cm b) 30 cm
c) 10 cm d) 60 cm
- B. Answer as directed :**
- The colour of light which travels with the maximum speed in glass is _____.
 - The rising sun appears to be higher in the sky than actually it is. (True/False)
 - Rainbow is formed in the air due to dispersion of light by _____.
 - A light ray is refracted from ice to water. The refracted ray bends away from the normal. (Yes/No.)
 - Refractive index varies _____ of wavelength of light.
 - Is the absolute refractive index of any medium is always greater than one ?
 - An astronaut in a space ship sees the sky away from the sun as _____.
 - Does transparency of a medium depend upon its thickness ?
 - When a glass slab is placed on a cross made on a sheet, the cross appears raised by 1 cm. The thickness of the glass is 3 cm. What is the critical angle for glass ?
 - If the length of the day on earth is defined as the time-interval between the sunrise and sunset, how will be day affected if earth loses its atmosphere ?
- C. Very Short Answer Type Questions :**
- The critical angle of a medium is 60° . Find its refractive index.
 - Due to what phenomenon, an air bubble in water shines ?
 - Show that the refractive index of a liquid, which produces a minimum deviation of 30° when placed in a hollow prism of angle 60° is 1.41.

4. What type of image will be produced by a concave lens for real objects ?
 5. What is the power of a convex lens of focal length 1 meter ?
 6. A lens of power +2D is placed in contact with a lens of power - 1D. How will this combination behave?
 7. A convex lens is dipped in a liquid whose refractive index is equal to the material of the lens. What will be its focal length ?
 8. A real object is placed before a convex lens on its axis and at a distance less than the focal length of the lens. What will be the nature of the image ?
 9. Does the power of a convex lens depend on the convention of signs adopted ?
 10. Why white light is dispersed by a prism ?
 11. When light undergoes refraction, what happens to frequency? [CBSE AI 2000C]
 12. How does the frequency of a beam of UV light change when it goes from air to glass ? [CBSE 2000]
 13. Refractive index of glass for light of yellow, green and red colours are n_y , n_g and n_r respectively. Rearrange these symbols in an increasing order of values. [CBSE AI 1987]
 14. In which direction relative to normal does a ray of light bend when it enters obliquely in a medium in which its speed is reduced. [CBSE 1999]
 15. For the same angle of incidence the angle of refraction in three different media A, B and C are 15° , 25° and 35° respectively. In which medium the velocity of light is minimum ? [CBSE 1999 C, 94]
- D. Short Answer Type Questions :**
1. Why, during hot days at noon, trees and houses across open ground appear to be quivering ?
 2. Why does an air bubble in a jar of water shine brightly ?
 3. Why does a diamond sparkle more than a glass-imitation cut to same size ?
 4. Why is a right-angled Prism a better reflector than a plain silvered mirror ?
 5. On what factors does the focal length of a lens depend ?
 6. A convex lens, a glass slab, a glass prism and a spherical solid ball have been prepared from the same optically transparent material. Explain which of them will possess dispersive power ?
 7. The radii of curvature of both the surfaces of a lens are equal. If one of the surfaces is made plane by grinding, find the new focal length.
 8. An object is placed at the focus of a concave lens. Where will be image be formed ?
 9. A lens, whose radii of curvature are different, is forming the image of an object placed on its axis. If the lens is reversed, will the position of the image change ? Explain.
 10. A thin convex lens is put in contact with a thin concave lens of the same focal length. Show that the resultant combination has a power equal to zero.
 11. An object is placed at the principal focus of a convex lens of focal length f . Where will its image be formed ? [CBSE AI 2008, 2003]
 12. The refractive index of a material of a convex lens is n_1 . It is immersed in a medium of refractive index n_2 . A parallel beam of light is incident on the lens. Trace the path of the emergent rays when $n_2 > n_1$. [CBSE 2002 C]
 13. A glass convex lens is placed in water. Will there be any change in focal length? Give reason. [CBSE 2000 C]
 14. A converging lens of refractive index 1.5 is kept in a liquid medium having same

refractive index. What is the focal length of the lens in this medium ?

[CBSE Delhi 2008]

15. A diverging lens of focal length 'f' is cut into two identical parts, each forming a plano concave lens. What is the focal length of each part ? [CBSE AI 2008]

E. Long Answer Type Questions :

1. What is refractive index ? Deduce the formula
$$\mu = \frac{\sin\left(\frac{A + D_m}{2}\right)}{\sin\frac{A}{2}}$$
 for refraction of light through a prism.

2. What is meant by critical angle for a given refracting medium ? Establish a relation between critical angle and refractive index. What is total internal reflection and when does it take place ?

3. Prove that for a spherical refracting surface
$$\frac{\mu}{v} - \frac{1}{u} = \frac{\mu - 1}{R}$$
 where μ = Refractive index of the medium of refracting surface.

R = Radius of the spherical surface

u and v are the object and image distances respectively from the pole of the surface.

4. Prove the formula :
$$\frac{1}{f} = (\mu - 1) \left(\frac{1}{r_1} - \frac{1}{r_2} \right)$$

for curved refracting surfaces, the symbols having their usual significance.

5. Deduce an expression for the focal length of a lens in terms of u and v.
6. Describe the appearance and position of the image produced by a convex lens as

the object moves from infinity towards the lens, with the help of ray-diagrams.

7. What is transverse magnification ? Derive an expression, with the help of ray-diagrams, for magnification for different type of images in convex and concave lenses.
8. What is dispersion ? Define dispersive power, angular dispersion and establish a relation between them.

F. Numerical Problems :

1. Given ${}_a\mu_g = \frac{3}{2}$ and ${}_a\mu_w = \frac{4}{3}$

Find ${}_w\mu_g$ and the corresponding critical angle.

2. A prism of refractive index $\sqrt{2}$ has a refracting angle of 60° . At what angle a ray must be incident on it, so that it suffers a minimum deviation ?
3. A ray of monochromatic light is incident on the refracting face of a Prism angle 75° . It passes through the prism and is incident on the other face at the critical angle. If refractive index of the prism is $\sqrt{2}$, what is the angle of incidence on the first face of the Prism ?
4. A ray of light is incident at an angle of 60° on one face of a Prism which has an angle of 30° . The ray emerging out of the Prism makes an angle 30° with the incident ray. Show that the emergent ray is perpendicular to the face through which it emerges and calculate the refractive index of the prism.
5. Refractive index of crown glass for red, yellow, violet colours are 1.5140, 1.5170 and 1.5318 respectively and for flint glass are 1.6434, 1.6499 and 1.6852

- respectively. Find the dispersive power of crown and flint glass.
6. Radius of each surface of a convex lens is 20 cm and refractive index of the material of the lens is $\frac{3}{2}$.
- Calculate its focal length
 - If it is vertically divided into two equal halves, find focal length.
 - If it is horizontally divided into two equal halves, find focal length.
7. A thin lens has focal length f and its aperture has diameter d . It forms an image of intensity I . Now the central part of the aperture upto diameter $d/2$ is blocked by an opaque paper. Find out the change of focal length and intensity.
8. A concave and convex lens have the same focal length of 20 cm and are put into contact to form a lens combination. The combination is used to view an object of 5 cm length kept at 20 cm from the lens combination. Compare the nature and size of the image with the object.
9. A double convex lens made of glass of refractive index 1.5 has both radii of curvature of magnitude 20 cm. Find where the incident light rays parallel to axis of the lens will converge.
10. A slide projector gives a magnification of 10. If it projects a slide of dimensions 3 cm x 2 cm on a screen, find the area of the image on the screen.
11. The radii of curvature of the faces of a double convex lens are 10 cm and 15 cm. If the focal length of the lens is 12 cm, find the refractive of the material of the lens. [CBSE Delhi 2010]
12. A double convex lens of glass of refractive index 1.6 has its both surfaces of equal radii of curvature of 30 cm each. An object of height 5 cm is placed at a distance of 12.5 cm from the lens. Calculate the size of the image formed. [CBSE AI 2007, 2005]
13. An illuminated object and a screen are placed 90 cm apart. Determine the focal length and nature of the lens required to produce clear image on the screen, twice the size of the object. [CBSE AI 2010]
14. Two lenses of power 10 D and -5 D are placed in contact. (i) Calculate the power of lens combination. (ii) Where should an object be held from the lens, so as to obtain a virtual image of magnification 2? [CBSE AI 2008, 2008 C]
15. A ray of light passing through an equilateral triangular prism from air undergoes minimum deviation when angle of incidence is $\frac{3}{4}$ th of the angle of prism. Calculate the speed of light in the prism. [CBSE 2008]
- G. Correct the following sentences :**
- When a light ray is refracted from water to air the refracted ray bends towards the normal.
 - The total internal reflection is possible when light travels from rarer to denser medium.
 - Transparency of a medium does not depend on its thickness.
 - Blue light travels with the maximum speed in glass.
 - During dispersion through a prism, the blue colour is most deviated.
 - If the critical angle for a medium is 60° , then the refractive index of the medium is $\sqrt{3}/2$.
 - The power of a convex lens of focal length 2 meter is 2 dioptre.

13

Eye and Optical Instruments

13.1: Eye :

Eye is an invaluable gift of nature to us. It is a splendid optical instrument. Different parts of our eye are kept inside a nearly spherical ball capable of movements in a socket.

An important constituent of human eye is a focussing bi-convex lens (L), which is more convex at the back. It is kept hanging inside the eye-ball with the help of suspensory ligaments. The eye-lens is composed of different values of refractive index. The lens divides the eye-ball into two chambers. (i) Anterior chamber, filled with watery liquid called aqueous humour of refractive index 1.34. (ii) Posterior chamber, filled with a transparent jelly like fluid called vitreous humour of refractive index 1.34.

When rays from an object enter an eye, they are subject to refraction in different parts of the eye. The cornea (C), which is the front portion of the eye, refracts the light most. These refracted rays inside the eye are further refracted by the eye-lens. Finally the image, appears on the retina R - which is the light-sensitive screen at the back of the eye.

The image, produced by the (convergent) eye - lens is diminished, real and inverted. However we are accustomed to see them erect by a process of mental interpretation.

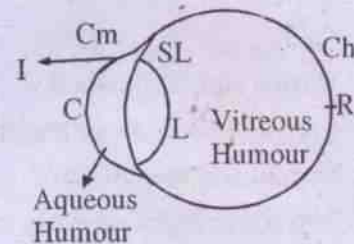

Fig. 13.1 (Human Eye)

Choroid (Ch) : It has two parts :

(i) Its front portion is transparent, through which light enters the eye from the object. It is called cornea (C).

(ii) The other portion of choroid is located on the internal back part, which is covered by a purple-red membrane, consisting of a large number of rods and cones. The rods and cones receive the light waves and communicate the visual sensation to the brain through optic nerve fibres.

Cm = Ciliary muscles. Ciliary muscles, when contracted, will be in a position to bulge the eye-lens, thus, reducing the focal length of the eye-lens. By reverse-action, it can increase focal length. This is responsible for the accommodation of the eye. The ciliary muscles hold the Iris.

I = Iris (circular diaphragm). The aperture of the Iris is called the pupil. The aperture changes, as per requirement. Its colour gives the colour of the eye.

SL = Suspensory Ligaments. The focussing lens (L) is hung through them.

It should be noted that the image must be formed on the Retina (located at the back of the eye) for objects to be observed clearly.

13.2: Power of accommodation :

We know that the eye can see not only distant objects but also near objects at ease. This only proves that the eye lens is not having a rigidly fixed focal length. Its focal length is so adjustable that it is capable to change it, as per requirement, so that it can see both far and near objects without any eye-strain. This property of the eye is called its power of accommodation.

Accommodation is that property of the eye-lens, by which its effective focal length is automatically altered, so as to suit the act of viewing distant or near objects.

13.3: Persistence of vision :

Take a card-board. Suppose on one side, you draw the diagram of a tiger and on the other side that of a big cage. If the card-board is rapidly rotated about a vertical axis, it will appear as if the tiger is inside the cage.

The reason is due to the persistence of vision which is the property of the eye. Suppose we look at a picture. Then its image lasts in our mind for about $\frac{1}{10}$ th of a second. If during this time-interval, the picture is removed from our eye-sight and is again brought back, then our eye will not be able to note this temporary disappearance of the picture.

That is why in the above case, even if the pictures of the cage and tiger are separate and are temporarily out of sight due to rotation, we are unable to note them, because the time of absence is very short, say, less than $\frac{1}{10}$ th of a second.

13.4: Far-point of the eye :

It is the farthest point, upto which the

eye can see an object distinctly without strain. Theoretically this is infinity for a normal eye.

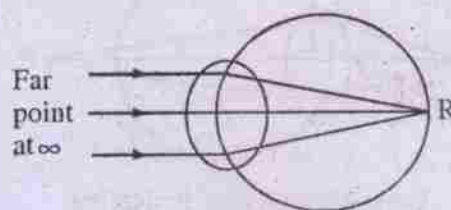

Fig. 13.2 (Normal eye : Far point)

13.5: Near-point of the eye :

It is the least distance, beyond which the eye can see an object clearly with full relaxation. For a normal eye, this is 25 cm. This marks the limit of the power of accommodation of the eye.

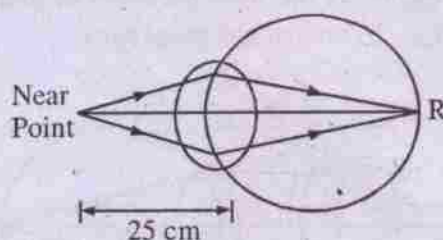

Fig. 13.3 (Normal eye : Near point)

13.6: Defects of vision :

The common defects of vision are :

- (a) Long-sight (Hypermetropia)
- (b) Short-sight (Myopia)
- (c) Presbyopia
- (d) Astigmatism
- (e) Phorias
- (g) Colour-blindness

(a) Long sight :

A man suffering from this defect can see distant objects, but not near-objects, i.e. its Near-point (N) is more than 25cm, as meant for a normal eye.

Causes :

- (1) The eye-ball is small.
- (2) The focal length of the eye-lens is large.

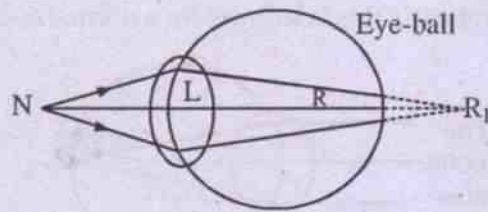

Long-sighted eye R=Ratina

Fig. 13.4

Here the near-objects are not focussed on retina, but behind it (R_1).

Remedy :

The object at N should be brought to N_1 (where N_1 is the least distance of distinct vision, i.e., 25 cm for a normal eye)

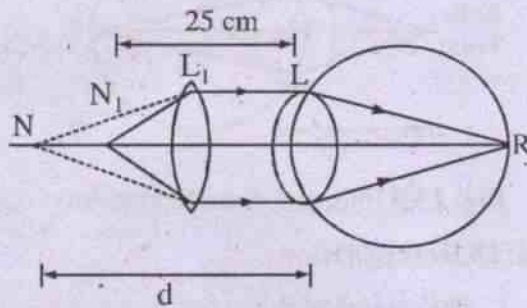

Long-sighted eye : Remedy

Fig. 13.5

Hence $u = -d$
 $v = -D (= 25\text{cm})$ } with sign convention

Assume that L_1 (the lens to be used in spectacles as a remedy) and L (eye-lens) are very close to each other.

Using the above u and v values in the lens formula

$$\frac{1}{v} - \frac{1}{u} = \frac{1}{f}$$

we get $\frac{1}{-25} + \frac{1}{d} = \frac{1}{f}$

where $f =$ focal length of L_1

so that $f = \frac{d-25}{25d}$...13.6.1

Since for a long-sighted person, $d > 25\text{cm}$, f should be +ve, i.e., the lens, to be used as a remedy, should be convex.

(b) Short-sight:

With this defect, a person can see near objects (i.e., objects at or somewhat beyond 25cm) but not very distant objects (as is possible for a normal person, who can see, theoretically as large as, upto infinite distance). Here the distant objects are focussed not on the retina (R), but in front of it (R_1).

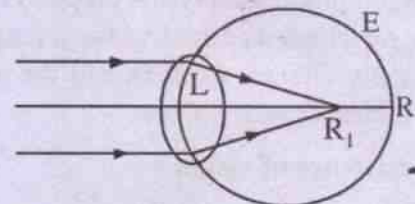

Short-sighted eye

Fig. 13.6

Causes :

The defect may be due to

- (1) Eye ball is too elongated
- (2) Focal length of the eye is short.

Remedy :

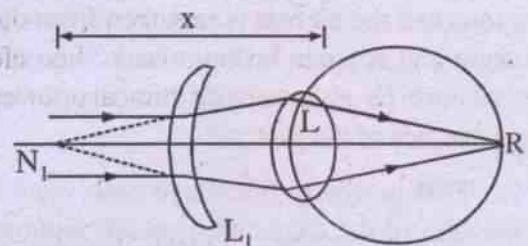

Short-sighted eye : Remedy

Fig. 13.7

$N_1 =$ Farthest point, upto which the defective eye can see.

$N_1L = x$ (say)

In an ideal case, a person should see upto

∞ . Hence an object at ∞ should be brought to N_1 , so that the defective eye will be able to see it.

Hence $u = \infty$

$$v = -x \text{ (with sign convention)}$$

Using the u - v relation $\frac{1}{v} - \frac{1}{\infty} = \frac{1}{f}$, we have

$$\frac{1}{-x} - \frac{1}{\infty} = \frac{1}{f}$$

$$\therefore f = -x \quad \dots 13.6.2$$

The -ve sign indicates that the remedial lens L_1 (i.e., the lens of the spectacles) should be concave and its focal length should be equal to the farthest distance, upto which the defective eye can see.

(c) *Presbyopia (Far-sight)* :

This is due to old age, caused by the decrease in the elasticity of eye-lens. It is one type of long-sight. Hence a child, suffering from short-sightedness will become normal in old age due to presbyopia. Thus presbyopia will be a boon to him.

(d) *Astigmatism* :

Suppose a person, suffering from this defect, looks at a network, consisting of horizontal and vertical wires. If he will focus his eyes on the horizontal wires, then the vertical wires will appear curved or unclear. This defect can be remedied by using a cylindrical or spherocylindrical lens.

(e) *Phorias* :

We are gifted by nature with the two eyes, for binocular vision (i.e., the power of estimating distances of different objects correctly). However, if there is defect in the proper orientation between the two eyes of a person, he suffers from phorias. This will cause eye-strain and headache while viewing objects. By using prismatic lenses, this defect can be removed.

(f) *Colour-blindness* :

Suppose our eye cannot detect red colour. Then if we look at a red object, it will appear dark. This is a case of colour-blindness.

Colour-blindness is incurable. Due to this, the eye will be incapable of responding to a particular colour.

13.7: Optical instruments :

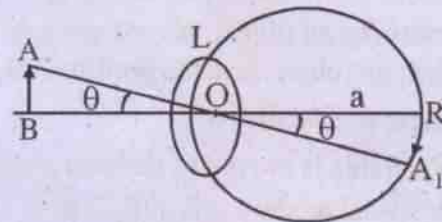

Visual angle
Fig. 13.8

(a) *Visual angle* :

L = Eye-lens

R = Retina

AB = object

A_1R = Image

Let the angle created by the object AB at the eye = $\angle AOB = \theta$ (known as visual angle)

OR = Diameter of the eye-ball = a (say)

$\angle AOB = \angle RAO_1 = \theta$ (being opposite)

The length of the image (RA_1) can be written as :

$$RA_1 = a\theta$$

since 'a' is a constant,

$$\therefore \text{Length of an image} \propto \theta$$

This shows that the greater the visual angle, the greater will be the size of the image (i.e., the object will be consequently seen in greater size).

The importance of the visual angle will be realized from the following figure :

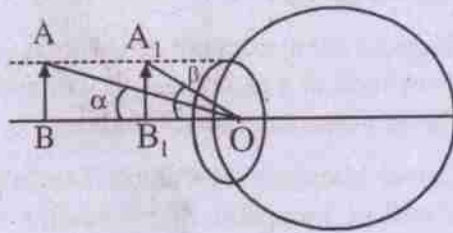

Visual angle : Importance

Fig. 13.9

Let us consider an object, placed erect on the axis. When this object is in the position 'AB', the visual angle = $\angle AOB = \alpha$.

When this is moved to the new position A_1B_1 the visual angle = $\angle A_1OB_1 = \beta$.

Since $\beta > \alpha$, the object at A_1B_1 will appear to be bigger than AB to the eye; even though the object height (i.e. physical size) at both the positions is same.

Hence when we are dealing with optical instruments like microscopes, telescopes etc, we should bear in mind that the visual angle is increased, so that objects can be seen distinctly.

(b) Angular magnification :

Let α = Visual angle produced by an object, when seen without an optical instrument (i.e., unaided eye)

α' = Visual angle subtended, by using an optical instrument.

Then angular magnification (M) is defined as

$$M = \frac{\alpha'}{\alpha} \quad \dots 13.7.1$$

It is necessary that an optical instrument be so designed such that $\alpha' > \alpha$, as this will result in a magnified image. It should be remembered that we are less interested in the physical size of the objects or their images; but more in their visual angles.

13.8: Microscope :

It is an optical instrument to view 'near' objects. Scientist Hooke, in 1648 was able to

discover 'cells' in vegetable and animal tissue, with its use.

We shall deal with microscopes in two categories.

(a) Simple microscope (which consists of a single lens)

(b) Compound microscope (consisting of more than one convex lens)

(a) Simple microscope :

(Magnifying glass / Reading glass / Magnifier)

Simple microscope uses the principle that when an object is placed between optic center and focus of a convex lens, an erect, magnified and virtual image is formed on the same side of the lens.

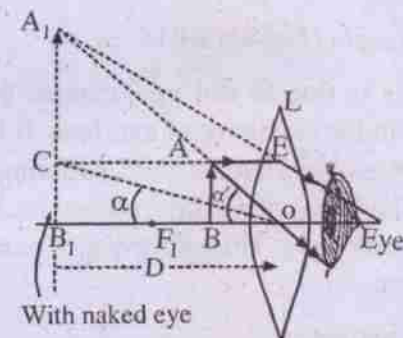

Simple microscope

Fig.13.10

L = convex lens of focal length f

AB = object placed between optic center and focus (Here $OF_1 < \text{least distance of distinct vision, } D$, due to which the object is not clearly visible to the unaided eye).

A_1B_1 = Image (The distance between the object AB and lens be so adjusted that the image A_1B_1 is formed at the least distance of distinct vision, D)

$OB_1 = D$

$\angle COB_1 = \alpha$ = Angle subtended by the object AB, if it would have been placed at D.

$\angle A_1OB_1 = \alpha' =$ Angle subtended by the image A_1B_1 , which is formed at D (by experimental adjustment)

Magnifying power :

It is defined as the ratio of the angle subtended at the eye by the image to that subtended by the object, when placed at the least distance distinct vision.

Thus Magnifying power = M

$$= \frac{\alpha'}{\alpha}$$

$$= \frac{\text{Tan}\alpha'}{\text{Tan}\alpha}$$

(since α' and α are small)

$$= \frac{(A_1B_1 / B_1O)}{(CB_1 / B_1O)}$$

$$= A_1B_1 / CB_1$$

$$= A_1B_1 / AB$$

$$= OB_1 / OB$$

(\because triangles OAB and OA_1B_1 are similar)

$$= -D / -u \quad (\text{with sign convention})$$

$$M = D/u \quad \dots 13.8.1$$

We shall use now the lens-formula: $\frac{1}{v} - \frac{1}{u} = \frac{1}{f}$

Here $v = -D$

and $u = -u$ (with sign convention)

so that the lens formula gives

$$-\frac{1}{D} + \frac{1}{u} = \frac{1}{f}$$

Multiplying by D throughout,

$$-1 + \frac{D}{u} = \frac{D}{f}$$

$$\text{or, } \frac{D}{u} = 1 + \frac{D}{f} \quad \dots 13.8.2$$

Comparing eqns 13.8(1 & 2), we obtain

$$M = 1 + \frac{D}{f} \quad \dots 13.8.3$$

Thus if focal length of the lens is less, its magnification will increase.

Since the purpose of a simple microscope is to get large magnification, we should use convex lens of short focal length (f). This means that lenses with large curvature need to be constructed by grinding lenses. However this often leads to many difficulties. Hence there is need to go for other type of microscope - compound microscope - for larger magnification.

Best position where the eye is to be placed :

Suppose the distance between the eye and lens = a

Hence $v =$ Image distance = $D - a$

Thus replacing D by $D - a$ in eqn. (13.8.3), we get

$$M = 1 + \frac{D - a}{f} \quad \dots 13.8.4$$

Hence M will be large, when 'a' is almost zero. So the best position of the eye will be the position, very close to the lens. An added advantage for this position is that chromatic aberration (- a defect due to which coloured image is produced for a white object) can be avoided.

Magnifying glass with image at infinity :

Rewriting eqn. (13.8.4)

$$M = 1 + \frac{D}{f}$$

We note that this magnification is meant for the image which is formed at D. Here we had placed the object between O and F - and this position is called the Normal setting. Let us denote M by $M_{\text{near point}}$. Hence

$$M_{\text{near point}} = 1 + \frac{D}{f} \quad \dots 13.8.5$$

Now we shall consider the case, when the image is formed at ∞ . This can happen, when the object is placed at the focus of the lens. Thus now $u = f$ (where $f =$ focal length of the lens)

So that eqn. (13.8.1) gives

$$\begin{aligned} M_{\infty} &= D/u \\ &= D/f \quad \dots 13.8.6 \end{aligned}$$

Comparing eqns. 13.8 (5 & 6) we find that

$$M_{\text{near point}} = 1 + M_{\infty} \quad \dots 13.8.7$$

This proves that the magnification at near point is larger than that at infinity.

(b) *Compound microscope :*

When we use two co-axial convex lenses, separated from each other, we shall get angular magnification, which is much higher than a simple microscope. Thus a compound microscope is more suitable to have magnified images of small and near objects.

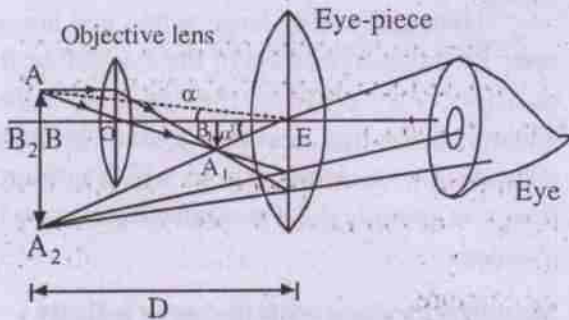

Compound Microscope : Normal setting

Fig. 13.11

AB = object

OB = This distance is slightly more than the focal length (f_o) of the objective lens O (objective lens is so called, because it is turned towards the object) u_o (say)

A_1B_1 = Image formed due to the objective lens (this is real, inverted and magnified)

$OB_1 = v_o$

E = Eye-lens, near to which the eye is placed for viewing object.

$EB_1 = u_e$

For the eye lens E, A_1B_1 acts as the object. E is kept at such a position that the distance B_1E is less than the focal length of the eye-lens (f_e), so that a virtual, magnified and (erect with respect to A_1B_1 , but inverted with respect to AB) is formed at the least distance of distinct vision D.

$EB_2 = D$

The objective and the eye-lens are kept co-axially in a hollow metal tube of approximate length ($u_e + v_o$), which can be changed as per requirement by rack and pinion arrangement. There is provision of cross-wires at the position A_1B_1 , so that they can be used for taking different measurements.

Magnification at normal setting :

This is the setting, in which the final image A_2B_2 is formed at D.

By definition,

$$\text{Magnification} = M_{\text{near point}}$$

$$= \left(\frac{\text{Angle subtended by the image, formed at D}}{\text{Angle subtended by the object, if placed at D}} \right) \text{ at the eye} \quad \dots 13.8.8$$

But angle subtended by the final image A_2B_2 (formed at D) at the eye = α'

Angle subtended by the object AB (which is at a distance D from the eye) at the eye = α

Hence eqn. 13.8.8 gives,

$$\begin{aligned}
 M_{\text{Near-point}} &= \frac{\alpha'}{\alpha} \\
 &= \frac{\tan \alpha'}{\tan \alpha} \\
 &\quad (\alpha, \alpha' \text{ being small}) \\
 &= \frac{A_2B_2 / B_2E}{AB / BE} \\
 &= \frac{A_2B_2}{AB} \quad (\because B_2E = BE) \\
 &= \frac{A_2B_2}{A_1B_1} \cdot \frac{A_1B_1}{AB} \\
 &= \left(\text{Magnification due to eye-lens} \right) \left(\text{Magnification due to objective} \right) \\
 &= M_e \times M_o \quad \dots 13.8.9
 \end{aligned}$$

But Magnification due to objective = M_o

$$= \frac{v_o}{-u_o} \quad (\text{with sign convention}) \quad \dots 13.8.10$$

Using the u-v relation $\frac{1}{v} - \frac{1}{u} = \frac{1}{f}$ for the objective lens, with sign convention, we get

$$\frac{1}{+v_o} - \frac{1}{-u_o} = \frac{1}{f_o}$$

$$\text{or, } \frac{1}{v_o} + \frac{1}{u_o} = \frac{1}{f_o}$$

$$\text{or, } \frac{v_o}{u_o} = \left(\frac{v_o}{f_o} - 1 \right) \quad \dots 13.8.11$$

$$\text{so that } M_o = - \left(\frac{v_o}{f_o} - 1 \right) \quad \dots 13.8.12$$

Further the eye-lens is acting here as a simple microscope or magnifier, the magnification of which is given by eqn. (13.8.3):

$$M_e = 1 + \frac{D}{f_e} \quad \dots 13.8.13$$

Substituting eqns. 13.8. (12 & 13) in (13.8.9):

$$M_{\text{Near-point}} = - \left(\frac{v_o}{f_o} - 1 \right) \left(1 + \frac{D}{f_e} \right) \quad \dots 13.8.14$$

The -ve sign indicates that the image is virtual, but inverted (with respect to the object AB).

Since $M = M_o \times M_e$, we see that magnifying power of the compound microscope is M_o times the magnifying power of a simple microscope (M_e). But because M_o increases when v_o increases (Ref eqn. 13.8.12), the length of the microscope tube ($v_o + u_e$) consequently increases.

Further magnification can be enhanced by decreasing the focal lengths of the objective and eye-lens (f_o and f_e).

In fact, in a compound microscope, the objective is of short focal length and aperture, while the eye-lens is of short focal length but wider aperture.

Magnification, when final image is at infinity :

In the 'Normal setting' (previous case), we had the final image A_2B_2 at D.

Now we shall discuss the case, where the final image is to be formed at ∞ . This is possible if A_1B_1 is set at the first principal focus of the eye-lens (i.e., $EB_1 = f_e$).

\therefore Magnification, when final image is at ∞

$$\begin{aligned} &= M_\infty \\ &= \frac{\tan \alpha'}{\tan \alpha} \\ &(\because \alpha \text{ \& } \alpha' \text{ being small}) \end{aligned}$$

$$\begin{aligned} &= \frac{A_1B_1 / EB_1}{AB / EB} \\ &= \frac{A_1B_1}{AB} \cdot \frac{EB}{EB_1} \end{aligned}$$

$$\text{or, } M_\infty = \frac{A_1B_1}{AB} \cdot \frac{D}{f_e}$$

$$\begin{aligned} \text{But } \frac{A_1B_1}{AB} &= \frac{OB_1}{OB} \\ &(\because \text{triangles } AOB \text{ and } A_1OB_1 \text{ are similar}) \end{aligned}$$

$$\begin{aligned} \therefore M_\infty &= \frac{OB_1}{OB} \cdot \frac{D}{f_e} \\ &= \frac{v_o}{u_o} \cdot \frac{D}{f_e} \\ &= \frac{-v_o}{u_o} \cdot \frac{D}{f_e} \text{ with sign convention} \\ &= -\left(\frac{v_o}{f_o} - 1\right) \cdot \frac{D}{f_e} \text{ by eq. (13.8.11)} \\ &\dots 13.8.15 \end{aligned}$$

Comparing 13.8. (14.&15), we note that

$$M_{\text{normal setting}} > M_\infty \dots 13.8.16$$

13.9: Astronomical Telescope :

Telescope was first made in 1608. Galileo made and used a telescope to view distant objects like the satellites of Jupiter and the rings of Saturn.

Telescopes are of two types : Refracting type, using lenses, and reflecting type, using curved mirrors.

A. Reflecting Type :

An astronomical telescope is of refracting type.

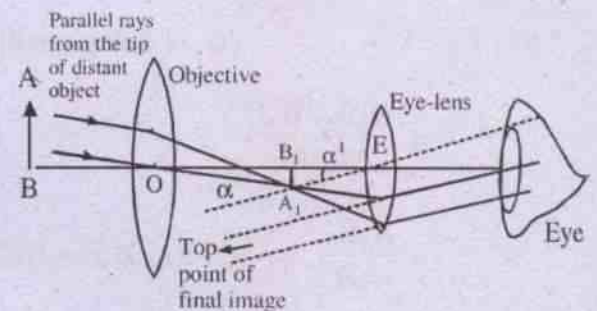

Astronomical telescope : Normal setting

Fig. 13.12

AB = object at ∞

O = objective lens = It is a convex lens of large focal length and aperture. It collects parallel rays from the distant object. The largeness of the aperture increases the brightness of the image.

E = Eyepiece = A convex lens of short focal length.

The functioning of the telescope can be studied in two positions :

- Normal setting (vision)
- Final image at near point (or, least distance of distinct vision).

(a) Normal position :

Fig. 13.12 depicts this position. The non-axial parallel rays are coming from the distant object (AB). After refraction at the objective lens, they form an image A_1B_1 (real, inverted,

highly diminished) in the focal plane of the objective.

Hence $OB_1 = f_o$, where $f_o =$ focal length of the objective. The eye-lens is so adjusted that A_1B_1 is positioned at the focal plane of the eye-lens. Hence A_1B_1 , which now acts as the object for the eye-lens, will have its image formed at infinity.

Thus, we have for the normal adjustment,

$$B_1E = f_e$$

where $f_e =$ focal length of the eye-lens.

The objective and the eye-lens are co-axial and kept in a hollow metal tube, so that, in the normal adjustment, we get :

$$\begin{aligned} \text{Length of the tube} &= OB_1 + B_1E \\ &= f_o + f_e \end{aligned}$$

By definition,

$M =$ Angular magnification

$$= \frac{\text{Angle subtended by the image at the eye}}{\text{Angle subtended by the object at the eye}}$$

$$= \frac{\alpha'}{\alpha}$$

(Even though α is the angle at the objective, we consider this as at the eye, since the distance OE can be neglected in comparison with the object distance, which is ∞)

$$\text{or, } M = \frac{\tan \alpha'}{\tan \alpha} \quad (\because \alpha \text{ \& } \alpha' \text{ are being small})$$

$$= \frac{A_1B_1 / B_1E}{A_1B_1 / OB_1}$$

$$= OB_1 / B_1E$$

$$= f_o / f_e \quad \dots 13.9.1$$

(b) Final image at Near point :

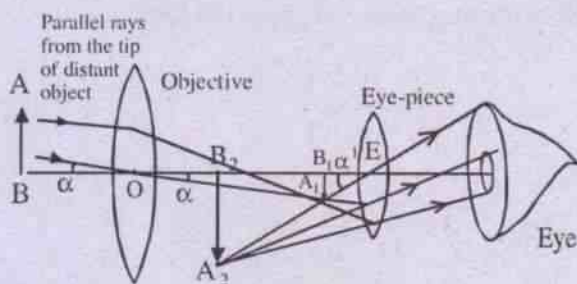

Astronomical telescope : Near point

Fig. 13.13

Parallel rays from the tip of the distant object form an image A_1B_1 (real, inverted and highly diminished) at the focal plane of the objective, so that $OB_1 = f_o$.

The eye-piece is so adjusted that A_1B_1 (which now acts as the object for eye-piece) is within the focal length of the eye-piece (i.e., $EB_1 < f_e$), which causes the formation of the final image A_2B_2 (virtual, inverted with respect to the object AB and magnified) at the least distance of distinct vision (i.e., $EB_2 = D$).

Now we shall find the angular magnification.

$M =$ Magnifying power

$$= \frac{\alpha'}{\alpha}$$

$$= \frac{\tan \alpha'}{\tan \alpha}$$

($\because \alpha \text{ \& } \alpha' \text{ are being small}$)

$$= \frac{A_1B_1 / B_1E}{A_1B_1 / OB_1}$$

$$= OB_1 / B_1E$$

$$= f_o / B_1E \quad \dots 13.9.2$$

For the eye-piece, object distance = $EB_1 = -u_e$

image distance = $EB_2 = -D$

Substituting these values in the lens-equns.

$$\frac{1}{v} - \frac{1}{u} = \frac{1}{f'}$$

we have
$$-\frac{1}{D} + \frac{1}{u_e} = \frac{1}{f_c}$$

or,
$$\frac{1}{u_e} = \frac{D + f_c}{f_c D}$$

or,
$$u_e = f_c D / D + f_c$$

Since $u_e = EB_1$, we substitute this in eqn. (13.9.2) and obtain

$$M = \frac{f_o(D + f_c)}{f_c D}$$

$$= \frac{f_o}{f_c} \left(1 + \frac{f_c}{D} \right) \quad \dots 13.9.3$$

This eqn. shows that f_o should be large and f_c small for large magnification.

Comparing eqn. 13.9 (1&3), we conclude

$$M_{\text{Near point}} > M_{\text{Normal vision}}$$

It should be noted that objectives of large aperture should be used, as they will not only make the magnified images brighter, they will also have large resolving power, as a result of which it will be possible to view the objects with minute details.

13.9 B. Reflecting Telescope:

Many of the larger astronomical telescopes use a parabolic-shaped concave mirror in place of objective lens (as in refracting type) as shown in Fig. 13.14 below. The light entering the telescope from a distant source is considered to be parallel.

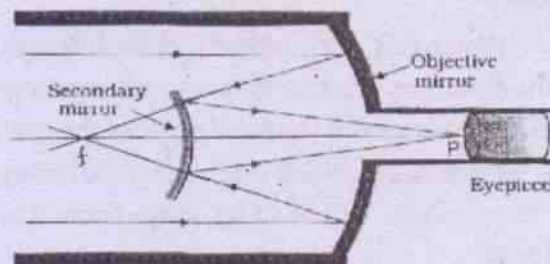

Fig. 13.14

When the rays strike the large concave mirror, they reflect in such a manner that they converge at the principal focus 'f'. The rays are intercepted before reaching 'f' by a smaller convex mirror which redirects the rays through a hole in the centre of the large concave mirror so that the rays now come to a focus at P. In practice, a camera or some other recording device such as a spectrograph is placed at this point P.

A reflecting telescope has the disadvantage that it is more liable to experience the problem of astigmatism and coma than do refracting telescopes. Because this problem is less serious in small refracting telescopes, reflecting telescopes are generally used in larger astronomical telescopes.

Ex.13.1 : A short-sighted person can read a book distinctly when it is held at 20 cm from his eyes. Find the focal length and power of lens, which he will use if he wishes to read a book at a distance of 80 cm.

Soln.

Object (Book) is placed at 80 cm.

$$\therefore u = -80 \text{ cm (with sign convention)}$$

The image of the book should be brought to 20 cm, so that it can be seen clearly.

$$\therefore v = -20 \text{ cm}$$

Hence the eqn. $\frac{1}{v} - \frac{1}{u} = \frac{1}{f}$ gives

$$\frac{1}{-20} - \frac{1}{-80} = \frac{1}{f}$$

$$\begin{aligned} \text{or, } \frac{1}{f} &= -\frac{1}{20} + \frac{1}{80} \\ &= \frac{-3}{80} \end{aligned}$$

$$\therefore f = \frac{-80}{3} \text{ cm} = -26.7 \text{ cm}$$

The -ve sign shows that the lens is concave.

$$\begin{aligned} P \text{ (in D)} &= \frac{1}{f \text{ (in met)}} \\ &= \frac{1}{-\left(\frac{80}{3 \times 100}\right)} \\ &= -\frac{300}{80} = -3.75 \text{ D} \end{aligned}$$

Ex.13.2: A long-sighted person has a minimum distance of distinct vision of 50 cm. What kind of lens must be used in order to reduce the distance to 25 cm? Find the focal length and power of the lens.

Soln.

As such, the person cannot see objects at 25 cm. Hence an object placed at 25 cm should form an image at 50 cm, for seeing the object

$$\begin{aligned} \therefore u &= -25 \text{ cm} \\ v &= -50 \text{ cm} \end{aligned}$$

$$\text{Hence } \frac{1}{50} - \frac{1}{-25} = \frac{1}{f}$$

$$\text{or, } \frac{1}{f} = -\frac{1}{50} + \frac{1}{25}$$

$$= \frac{1}{50}$$

$$f = +50 \text{ cm}$$

The lens to be used is a convex lens of focal length 50cm.

$$\therefore P \text{ (in D)} = \frac{1}{(50/100)} = +2 \text{ D}$$

Ex. 13.3: A short-sighted person sees objects most distinctly at a distance of 15 cm. If he wears his spectacles at a distance of 1 cm from his eyes, what focal length should they have so as to enable him to see distinctly at a distance of 29 cm.

Soln.

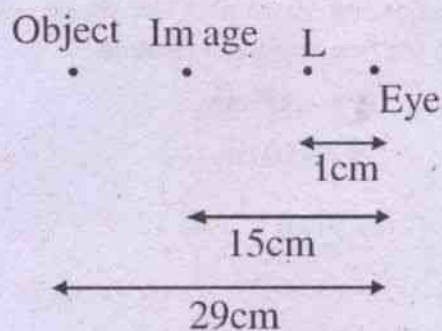

$$u = 29 - 1 = 28 \text{ cm}$$

$$v = 15 - 1 = 14 \text{ cm}$$

with sign convention :

$$u = -28 \text{ cm}$$

$$v = -14 \text{ cm}$$

so the u-v relation gives :

$$\frac{1}{f} = \frac{1}{-14} + \frac{1}{28}$$

$$= \frac{-1}{28}$$

$$\therefore f = -28 \text{ cm}$$

Hence the lens to be used is concave with focal length 28 cm.

Ex.13.4: A person can focus objects only when they lie between 50cm and 300 cm from his eyes. What spectacles he should use to increase his maximum distance of distinct vision to infinity. Find the range of distinct vision.

Soln.

An object at infinity should form its image at the far-point of 300cm to be seen clearly.

$$\therefore u = \infty$$

$$v = -300 \text{ cm (with sign convention)}$$

$$\therefore \frac{1}{f} = -\frac{1}{300} - \frac{1}{\infty}$$

$$\text{or, } f = -300 \text{ cm}$$

So the lens is concave of focal length 300 cm. To find the lower limit of vision, corresponding to the existing 50cm with the above concave lens in use, we apply u-v relation :

$$f = -300 \text{ cm}$$

$$v = -50 \text{ cm}$$

$$\therefore -\frac{1}{300} = \frac{1}{-50} - \frac{1}{u}$$

$$\text{or, } -\frac{1}{300} + \frac{1}{50} = -\frac{1}{u}$$

$$\text{or, } u = -60 \text{ cm}$$

Thus the range of distinct vision is now has the range from 60cm to ∞ .

Ex.13.5: A magnifying glass is made up of a combination of convex lens of power +20 D and a concave lens of power -4D. If the distance of distinct vision of the eye is 25 cm, calculate the magnifying power.

Soln.

$$\begin{aligned} P &= P_1 + P_2 \\ &= +20\text{D} - 4\text{D} \\ &= +16\text{D} \end{aligned}$$

$$\text{Power (in D)} = \frac{1}{f(\text{in met})}$$

$$\therefore f(\text{in met}) = \frac{1}{16}$$

$$\text{or, } f = \frac{100}{16} = \frac{25}{4} \text{ cm}$$

Magnifying power of a magnifying glass

$$= 1 + \frac{D}{f}$$

Here $D = 25 \text{ cm}$

$$\text{and } f = \frac{25}{4} \text{ cm}$$

(i.e. focal length of the combination of convex and concave lenses)

$$\therefore \text{Magnifying power} = 1 + \frac{25}{(25/4)} = 5$$

Ex. 13.6: Two convex lenses of focal lengths of 1 cm and 6 cm respectively are arranged to form a microscope. A small object is placed 1.2 cm from the objective. If the image appears to be 25cm from the eye-piece, what is the distance between the objective and the eye-piece ?

Soln.

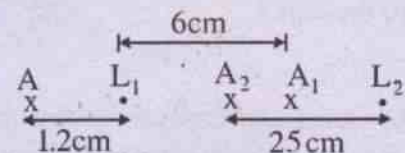

Consider objective (L_1):

$$u = -1.2 \text{ cm}$$

$$f_1 = +1 \text{ cm}$$

$$\therefore \frac{1}{v} + \frac{1}{1.2} = \frac{1}{1}$$

$$\begin{aligned} \text{or, } \frac{1}{v} &= 1 - \frac{1}{1.2} \\ &= \frac{1.2 - 1}{1.2} = \frac{.2}{1.2} \end{aligned}$$

$$\text{or, } v = +6 \text{ cm}$$

$$\therefore L_1 A_1 = 6 \text{ cm}$$

Consider eye-piece (L_2):

$$v = -25 \text{ cm}$$

$$f_2 = +6 \text{ cm}$$

$$\therefore -\frac{1}{25} - \frac{1}{u} = +\frac{1}{6}$$

$$\text{or, } -\frac{1}{u} = \frac{1}{6} + \frac{1}{25}$$

$$= \frac{31}{150}$$

$$\text{or, } u = \frac{-150}{31} \text{ cm}$$

$$\therefore L_2 A_1 = \frac{150}{31} = 4.84 \text{ cm}$$

Distance between objective and eyepiece

$$= L_1 L_2$$

$$= L_1 A_1 + A_1 L_2$$

$$= 6 + 4.84$$

$$= 10.84 \text{ cm}$$

Ex.13.7: In an astronomical refracting telescope, the focal length of the objective and the eyepiece are 80 cm and 4 cm respectively. Calculate the following if the final image forms at infinity: (i) magnifying power of the telescope (ii) Distance between the objective lens and the eyepiece.

Soln.

This is the adjustment for normal vision of the telescope.

Hence Magnifying power

$$= \frac{\text{focal length of the objective}}{\text{focal length of the eyepiece}}$$

$$\therefore M = \frac{f_o}{f_e}$$

$$= \frac{80}{4} = 20$$

Further in the normal vision position :

Distance between objective and eyepiece

$$= f_o + f_e$$

$$= 80 + 4$$

$$= 84 \text{ cm}$$

Ex.13.8: The focal lengths of objective and eyepiece of an astronomical telescope are 200cm and 5 cm respectively. Calculate the magnifying power, when the final image is formed at the least distance of distinct vision.

Soln.

This is the "final image at Near-point" arrangement of the telescope, for which the magnifying power is given by :

$$M = \frac{f_o}{f_e} \left(1 + \frac{f_e}{D} \right)$$

Here f_o = focal length of objective = 200cm

f_e = focal length of eyepiece = 5 cm

D = least distance of distinct vision = 25cm

$$\therefore M = \frac{200}{5} \left(1 + \frac{5}{25} \right)$$

$$= 40 \left(1 + \frac{1}{5} \right)$$

$$= 48$$

SUMMARY

1. Human eye :

Cornea, aqueous humour crystalline lens and vitreous humour form a series of refracting surfaces. The crystalline lens acts like a convex one, whose focal length changes with the help of ciliary muscles, thus enabling objects at different distances to be focused on the retina.

2. Defects of eye :

- a) Long-sight : A long-sighted person cannot see near objects distinctly. This is remedied by convex lens.
 - b) Short-sight : A short-sighted person cannot see distant objects clearly. This is remedied by concave lens.
 - c) Presbyopia : This is due to old age when there is loss of elasticity of the ciliary muscles and eye-lens. Bifocal lenses cure this defect.
 - d) Astigmatism : Due to this defect, a person cannot see clearly both the horizontal and vertical sections of the body. Cylindrical lenses can rectify this defect.
3. *Microscopes and telescopes are optical instruments, which are used to see respectively near and distant objects distinctly.*

- (a) Microscopes are of two types : Simple microscope and compound microscope.

In a simple microscope, one convex lens is used. Its magnifying power (M) is given by

$$M = 1 + \frac{D}{f}$$

where D = least distance of distinct vision.

f = focal length of the convex lens.

A compound microscope is a two-lens system [i.e., objective (o) and eye-piece (e)] and it produces greater magnification than a simple microscope. Its magnifying power is given by

$$M = \left(\frac{v_o}{f_o} - 1 \right) \left(1 + \frac{D}{f_e} \right)$$

where 'o' refers to objective

and 'e' refers to eye-piece

- (b) Astronomical telescope is a refracting telescope to see distant bodies.

Its magnifying power (M) is

$$M = \frac{f_o}{f_e}$$

where f_o = focal length of objective

and f_e = focal length of eye-piece

When the astronomical telescope is set for normal vision :

the distance between the objective and eye-piece = $f_o + f_e$

MODEL QUESTIONS

A. Multiple Choice Type Questions :

1. Loss of ability of eye to focus on near and far object with advancing age is called
 - a) Presbyopia
 - b) Astigmatism
 - c) Hypermetropia
 - d) Myopia
2. With a simple microscope, if the final image is located at the least distance of distinct vision, (i.e., D), from the eye placed close to the lens, then the magnifying power is
 - a) $\frac{D}{f}$
 - b) $1 + \frac{D}{f}$
 - c) $\frac{f}{D}$
 - d) $f \times D$
3. For distinct vision / normal vision, the eye is focussed on an object at
 - a) infinite distance
 - b) 25 cm away
 - c) 25 mm away
 - d) 25 meters away
4. A myopic patient uses
 - a) convex lens
 - b) concave lens
 - c) cylindrical lens
 - d) bifocal lens
5. A presbyopic patient can see objects only when they lie between 50 cm and 200 cm from the eye. Then the focal length of the correcting lens required while reading is
 - a) concave lens of focal length 50 cm
 - b) convex lens of focal length 50 cm
 - c) concave lens of focal length 300 cm
 - d) convex lens of focal length 300 cm
6. In question No. 5, the focal length of the correcting lens for seeing distant objects is
 - a) concave lens of focal length 50 cm
 - b) convex lens of focal length 50 cm
 - c) concave lens of focal length 200 cm
 - d) None of the above
7. The ratio of the focal length of the objective to the focal length of the eyepiece is greater than 1 for a
 - a) telescope
 - b) microscope
 - c) both telescope and microscope
 - d) neither telescope nor microscope
8. The focal length of the lens in the human eye is maximum when it is looking at an object at
 - a) infinity
 - b) 25 cm from the eye
 - c) 100 cm from the eye
 - d) a very small distance from the eye
9. With a simple microscope, if the final image is located at infinity, then its magnifying power is
 - a) D / f
 - b) $1 + D / f$
 - c) f / D
 - d) $D \times f$
10. An observer looks at a tree of height 15 meters with a telescope of magnifying power 10. To him the tree appears
 - a) 10 times taller
 - b) 15 times taller
 - c) 10 times nearer
 - d) 15 times nearer
11. An astronomical telescope has a converging eyepiece of focal length 5 cm and objective of focal length 80 cm. When the final image is formed at the least distance of distinct vision (25 cm), the separation between the two lenses is
 - a) 75 cm
 - b) 80 cm
 - c) 84.2 cm
 - d) 85 cm

12. The focal length of the objective and eye-lenses of a microscope are 1.6 and 2.5 cm respectively. The distance between the two lenses is 21.7 cm. If the final image is formed at infinity the distance between the object and objective lens is
- a) 1.8 cm b) 1.7 cm
c) 1.65 cm d) 1.75 cm
13. In question No. 12, the magnifying power of the microscope is
- a) 11 b) 121
c) 1.1 d) 44
14. For an astronomical telescope used in normal adjustment, objective and the eyepiece are separated by a distance of 55 cm. If the magnifying power of the telescope is 10, the power of the objective is
- a) 5 D b) 50 D
c) 2 D d) 0.5 D
15. A certain far-sighted person cannot see objects closer to the eye than 100 cm. The power of the lens which will enable him to read at a distance of 25 cm will be
- a) 3 dioptre b) 1 dioptre
c) 4 dioptre d) 2 dioptre
16. In a compound microscope, the focal lengths of objective and eye-lenses are 1.2 cm and 3 cm respectively. If the object is put 1.25 cm away from the objective lens and the final image is formed at infinity, the magnifying power of the microscope is
- a) 150 b) 200
c) 250 d) 400
17. In order to increase the magnifying power of a microscope
- a) the focal powers of the objective and eye-piece should be large.
b) objective should have small focal length and the eye-piece large.
c) both should have large focal lengths
d) the objective should have large focal length and eye-piece should have small focal length.
18. You are supplied with four convex lenses of focal lengths 100 cm, 25 cm, 3 cm and 2 cm. For designing an astronomical telescope, you will use lenses of focal lengths
- a) 100 cm and 25 cm
b) 100 cm and 3 cm
c) 25 cm and 2 cm
d) 100 cm and 2 cm
19. Astigmatism can be corrected by using
- a) Bifocal lenses
b) concave spherical lenses
c) plano-convex lenses
d) cylindrical lenses
20. The length of a simple astronomical telescope is
- a) the difference of the focal lengths of two lenses.
b) half the sum of focal lengths
c) the sum of the focal lengths
d) product of the focal lengths
21. A compound microscope has an objective and eye-piece as thin lenses of focal lengths 1 cm and 5 cm respectively. The distance between the objective and eye-piece is 20 cm. The distance at which the object must be placed in front of the objective, if the final image is located at 25 cm from the eye-piece is numerically
- a) $95/6$ b) 5
c) $95/89$ d) $25/6$

22. A hypermetropic person has to use a lens of power + 5 D to normalise his vision. The near point of the hypermetropic eye is
- 1m
 - 1.5 m
 - 0.5 m
 - 0.66 m
23. A person cannot see objects clearly beyond 200 cm. The power of the lens to correct the vision is
- +0.5 dioptrés
 - 0.5 dioptrés
 - +0.2 dioptrés
 - 0.2 dioptrés
24. How should people wearing their spectacles work with a microscope
- They should keep on wearing their spectacles
 - They should take off their spectacles
 - They may either put on their spectacles or they may take off their spectacles; it makes no difference
 - They cannot use the microscope at all.
25. A telescope has an objective of focal length 50 cm and an eyepiece of focal length 5 cm. It is focussed for distinct vision on a scale 200 cm away from the objective. Then the optical length of the telescope is
- 200 / 3 cm
 - 25 / 6 cm
 - 425 / 6 cm
 - 375 / 6 cm
26. In the human eye the focussing is done by
- To and fro movement of the eye lens.
 - To and fro movement of the retina
 - change in the convexity of the lens
 - change in the refractive index of the eye-fluid.
27. The magnifying power of compound microscope in terms of the magnification m_o due to objective and magnifying power m_e by the eye-piece is given by
- m_o / m_e
 - $m_o \times m_e$
 - $m_o + m_e$
 - m_e / m_o
28. An individual with one eye is likely to
- have stereoscopic vision
 - have binocular vision
 - misjudge distance
 - None of the above
29. The length of an astronomical telescope for normal vision is
- $f_o \times f_e$
 - f_o / f_e
 - f_e / f_o
 - $f_o + f_e$
30. Large apertures of telescope are used for
- greater magnification
 - greater resolution
 - reducing lens-aberration
 - ease of manufacture
31. The image of a distant object as seen through an astronomical telescope is
- erect
 - inverted
 - perverted
 - none
32. The final image produced by a simple microscope is
- erect
 - inverted
 - real and erect
 - real and inverted
33. The magnification is more than unity when object is placed at a distance d from a convex lens. Its focal length is 20 cm. What is d ?
- Greater than 20 cm
 - Less than 20 cm
 - 40 cm
 - Greater than 20 cm but less than 40cm.

34. When the length of a microscope tube increases, its magnifying power
- decreases
 - increases
 - does not change
 - may increase or decrease
35. The focal length of the objective of a microscope is
- greater than the focal length of the eye-piece.
 - less than the focal length of the eye-piece.
 - equal to the focal length of the eye-piece.
 - none of these
36. A man uses spectacles having concave lens of focal length 50 cm. He can see objects lying at 25 cm clearly by using the spectacles. How far a book must be kept from the eye-lens if he does not use his spectacles ?
- 33.3 cm
 - 50 cm
 - 25 cm
 - 50/3 cm
37. A book looks red when seen through a piece of red glass. Then the cover must be of
- red colour
 - white
 - green
 - red or white
38. The length of a telescope is 100 cm and magnification is 18. The focal lengths of objective and eye lens are nearly
- 90 cm and 10 cm
 - 85 cm and 15 cm
 - 80 cm and 20 cm
 - 95 cm and 5 cm

B. Answer as directed :

- Is spectrum of moon light emission spectra ? (Yes/No)

- Why red light is used for danger signal ?
- An endoscope is a narrow telescope or a simple microscope ?
- A spectrum is formed by a prism whose dispersive power is w . If the deviation of the mean ray is δ , the angular dispersion of the spectrum is ____.
- The magnifying power of an astronomical telescope is 8 and the distance between the two lenses is 54 cm. What is the focal length of eyelens and objective ?
- To increase magnifying power of a simple microscope what type of eye-piece you will choose : Higher or smaller focal length ?
- For a telescope, in which case the magnifying power is maximum : Normal adjustment or Near point adjustment.
- Why objective of large aperture is taken in a telescope ?
- Why eyepiece of small aperture is taken ?
- A star subtends an angle of 2° at eye. When seen through telescope, it subtends an angle of 40° at eye. The magnifying power of the telescope is ____.

C. Very Short Answer Type Questions :

- What lens should be used for the removal of long-sightedness ?
- What is the cause of short-sightedness ?
- How magnifying power of a magnifier is related to focal length ?
- How magnification of a compound microscope varies with the focal length of the eye-piece ?
- What is the distance between objective and eye-piece of an astronomical telescope for normal vision-setting ?

6. Astronomers prefer to use telescope with large objective diameters to observe astronomical objects. Explain why?

[CBSE Sample Paper]

7. Draw a ray diagram to show the image formation in a refracting type astronomical telescope in the near point adjustment. [CBSE AI 2008, 07, 04]
8. Draw a labeled ray diagram of a compound microscope. [CBSE AI 2010]

D. Short Answer Type Questions :

1. What is the function of the objective lens in an astronomical telescope ? Why should it have a long focal length and a large aperture ?
2. In what way a compound microscope is superior to a magnifying glass ?
3. What do you mean by normal setting of a compound microscope ? How its magnifying power differs, when it is set with the final image at infinity ?
4. What is meant by the normal setting of an astronomical telescope ? How its magnifying power differs, when it is set with the final image at near point ?
5. In what ways the size of the eye-ball is responsible for various defects of the eye ?
6. How the focal length of the eye-lens accounts for various defects of eye ?

E. Long Answer Type Questions :

1. What are short sighted and long-sightedness ? Describe their causes and remedies ?
2. What is a microscope ? Describe a simple microscope and derive an expression for its magnifying power.
3. Write notes on magnifying power of :
 - (a) a magnifier
 - (b) a compound microscope
 - (c) an astronomical telescope

4. With a neat ray diagram, describe the Principle, working and use of a compound microscope. What should be done for achieving large magnifying power ?

5. With a neat ray diagram, describe the Principle, working and use of an astronomical telescope.

F. Numerical Problems :

1. A short-sighted man can read printed matter distinctly when it is held 15cm from his eye. Find the focal length of the glasses which he must use if he wishes to read with ease a book at a distance of 60cm.
2. A long-sighted person can see clearly at any distance more than 100cm. What kind of lens should he use in spectacles to be able to read print placed at 25cm from his eye ? What is the power of this lens ?
3. A person can focus objects only when they lie between 0.5 m and 3m from his eyes. What spectacles should he use to increase his maximum distance of distinct vision to infinity.
4. A simple microscope is made of a combination of two lenses in contact of powers +15 D and +5 D. Calculate the magnifying power of the microscope if the image is formed at the least distance of distinct vision 0.25 meter.
5. The objective and eye-piece of a microscope have focal lengths 1 cm and 2cm respectively and separated by 12 cm. A person, whose distance of distinct vision is 25 cm uses the microscope to see a small object. Where must the object be placed ?
6. A telescope tube 80cm long provides a magnification of 19. Calculate the focal length of the objective and eye-piece.
7. A telescope has an objective of focal length 50cm and an eye-piece of focal

- length 5 cm. The least distance of distinct vision is 25cm. The telescope is focussed for distinct vision on a scale 200cm away from the object. Calculate the separation of the objective and the eye-piece.
8. In a compound microscope, an object is placed at a distance of 1.5 cm from the objective of focal length 1.25 cm. If the eye piece has a focal length of 5 cm and the final image is formed at the near point, estimate the magnifying power of the microscope. [CBSE 2010]
9. A compound microscope with an objective of 1.0 cm focal length and an eye-piece of 2.0 cm focal length has a tube length of 20 cm. Calculate the magnifying power of the microscope, if the final image is formed at near point of the eye. [CBSE 2004]
10. An astronomical telescope uses two lenses of powers 10 D and 1 D. What is magnifying power in normal adjustment? [CBSE AI 2010]
- G. Correct the following sentences :**
1. The distance of distinct vision for a normal eye is 30 cm.
 2. A person suffering from long-sight can see near objects clearly but not distant objects.
 3. One of the reasons for short-sight in a person is flattening of the eye ball.
 4. The objective of telescope has small aperture.
 5. For a simple microscope with image at infinity the magnifying power M is given as $M = (1 + D)/f$, where D is the distance of distinct vision and f is the focal length of the lens used in simple microscope.
 6. A person suffering from long sight uses convex lens.
 7. The distance between objective and eye-piece of an astronomical telescope for normal vision setting is $(f_o + f_e)/2$.

ANSWERS**A. Multiple Choice Type Questions :**

1. (a) 2. (b) 3. (b) 4. (b) 5. (b) 6. (c) 7. (a) 8. (a)
9. (a) 10. (c) 11. (c) 12. (d) 13. (b) 14. (c) 15. (a) 16. (b)
17. (a) 18. (d) 19. (d) 20. (c) 21. (c) 22. (a) 23. (b) 24. (b)
25. (c) 26. (c) 27. (b) 28. (c) 29. (d) 30. (b) 31. (b) 32. (a)
33. (d) 34. (a) 35. (b) 36. (d) 37. (d) 38. (d)

- B.** 1. No. 2. It has high wavelength and scatters least 3. Narrow telescope 4. $8w$ 5. $f_e = 6$ cm
 $f_o = 48$ cm 6. Smaller focal length 7. Near point adjustment 8. To collect sufficient light
and form bright image of very distant objects 9. So that the whole light may enter the eye
10. 20.

C. Very Short Answer Type Questions :

1. Convex lens

F. Numerical Problems :

1. concave, 20 cm
2. convex, + 3D
3. Concave, 3m
4. 6
5. 1.11 cm from the objective
6. 76 cm, 4 cm
7. 70.83 cm
8. -30,
9. -270
10. -10

14

Wave Optics and Interference

14.1: Theories of light :

Any theory of light, to be successful, must take into account the following observed and experimentally verified facts about light :

- a. It is a form of energy
- b. It is capable of moving - even in vacuum.
- c. Rectilinear Propagation of light
- d. Reflection
- e. Refraction
- f. Simultaneous reflection, refraction and absorption.
- g. Dispersion
- h. Interference
- i. Diffraction
- j. Polarisation : Double refraction
- k. It exerts pressure
- l. Photo electric effect
- m. Spectrum of light
- n. Velocity of light is less in a denser than in a rarer medium. However it does not depend on the colour of light or temperature of the source.

There have been some important theories of light :

(i) Corpuscular Theory (Newton) 1575:

It says that light source emits material particles (corpuscles) of small size with little mass - moving with the velocity of light.

(ii) Wave Theory (Huygens) 1678 :

Light moves in the form of waves through a hypothetical medium, called ether. The great success of this theory is that it can explain satisfactorily interference, diffraction, polarisation which could not be explained by earlier theory.

(iii) Electromagnetic Theory (Maxwell) 1873 :

Light consists of electromagnetic waves and can move in vacuum.

(iv) Quantum theory (Max Planck) 1901 :

Light consists of particles, called photons.

(v) Dual nature of light :

Since neither the particle theory nor the wave theory can each independently explain all the phenomena or facts associated with light, now it is presumed that light sometimes behaves as a wave and sometimes as a particle. This wave-particle nature is called the dual nature of light.

14.2: Huygen's wave theory :

Huygen supposed that light energy is transmitted by waves. But since it is essential to have a medium (as in the case of sound waves)

for wave-propagation, he conceived of a hypothetical medium, called ether, which has very small density and large elasticity. Ether is continuous, pervading all space and matter. Thus this ether concept can explain the transmission of light from sun to earth through the vacuum of the inter-stellar space, since vacuum, as per Huygen's hypothesis, is also filled with ether.

Huygen's Principles of wave-propagation are :

(i) (a) Wave-front :

Consider a source of light. Each point of the source emits waves in all directions. These waves in turn vibrate the ether-particles of the medium. The continuous locus of the ether-particles, vibrating in the same phase (i.e, the same state of vibration) constitutes a wave-front.

Shape of wave-front :

The shape of the wave front is determined by the shape of the source.

For a point-source, the wave front is spherical, with the source as the center because the points on the sphere, being equidistant from the source are disturbed simultaneously and hence are in the same phase. (Fig 14.1 : O is the source, ABCD is the wave front - spherical)

In case, the source is in the form of a straight line, the wave front is cylindrical, with the source acting as the axis of the front. (Fig. 14.2 : OO' is the line-source; cylindrical wave front envelopes it symmetrically)

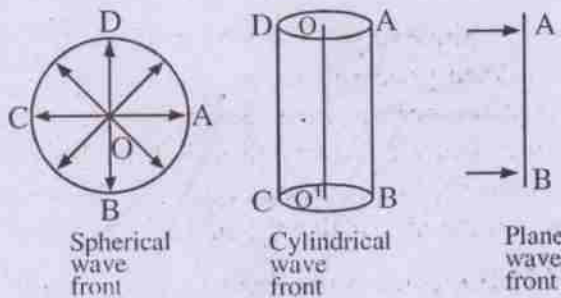
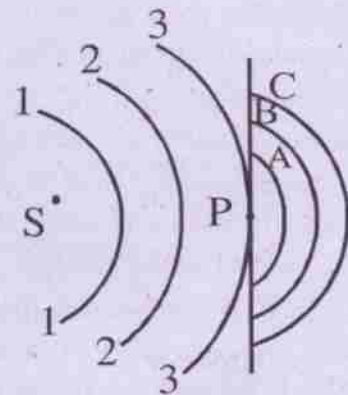

Fig. 14.1, 2 & 3

When the spherical / cylindrical wave front moves a very large distance, their radius increases. So their curvature decreases, i.e., they become more and more plane. Thus a plane wave-front is generated out of a portion of spherical or cylindrical wave-front with large radius.

(b) Secondary wave lets :

Each point on the wave front now becomes a new or secondary center of disturbance, so that fresh waves emanate out of it. These waves are called secondary wavelets, which travel in all directions with the velocity of light.



Secondary wavelets

Fig. 14.4

S = (Point) source of light

(1,1), (2,2), (3,3) = (Spherical)

wave fronts from S

P = A point on wavefront (3,3)

A,B,C = New waves (called secondary wavelets) start moving with their center at P. Thus the behaviour of point P is similar to that of S.

(ii) Construction of new wave front :

Now we shall consider how a wave front advances. For example, let us consider about what happens to the wave front (3,3) in Fig. 14.4 after a time interval t.

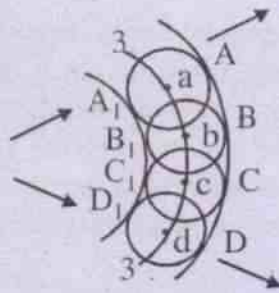

Fig. 14.5

All the points (say a, b, c, d...) in the wave front (3,3) will generate secondary spherical wavelets (A, A₁), (B, B₁), (C, C₁), (D, D₁).. of radius ct, where c is the velocity of light.

As seen in the Fig. 14.5, the points A, B, C, D are in the same phase. Hence by continuously joining these points (i.e, the loci), we get an envelope (ABCD) of these wavelets. It may be noted that A₁, B₁, C₁, D₁ are also having a common phase and their loci will be giving another envelope A₁B₁C₁D₁. However out of these two envelopes ABCD and A₁B₁C₁D₁, we accept the first one (ABCD), but reject A₁B₁C₁D₁, because the first one is in the forward direction (of light) whereas the second one is in the backward direction.

Huygen's theory says that the envelope of the secondary wavelets in the forward direction gives the position of the new wavefront at a subsequent time.

14.3 : Wave front and ray :

Ray is the direction, in which light energy is transmitted. In a homogenous, isotropic medium, ray is perpendicular to the wave front.

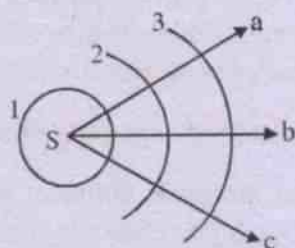
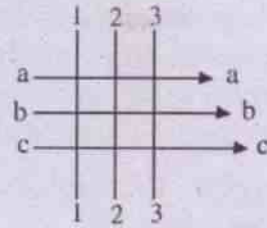

Fig. 14.6 (a) Wave front and Ray

S = point source of light
 1,2,3 = spherical wave front
 a,b,c, = Rays



Plane wave fronts (1,2,3) and rays (a,b,c)

Fig. 14.6 (b)

Rays are perpendicular to wave fronts

14.4 : Success of wave theory :

An important success of wave theory over corpuscular theory is that it satisfies experimental verification.

For example, as per corpuscular theory,

$${}^a\mu_w = \frac{\text{velocity of light in water}}{\text{velocity of light in air}} = \frac{v_w}{v_a}$$

But as per wave theory

$${}^a\mu_w = \frac{\text{velocity of light in air}}{\text{velocity of light in water}} = \frac{v_a}{v_w}$$

It is experimentally found that the formula, as derived in wave theory, is correct—showing that velocity of light in air is higher than that in water. (i.e., Velocity_{rarer medium} > Velocity_{denser medium})

14.5: Application of wave theory :

(a) Dispersion :

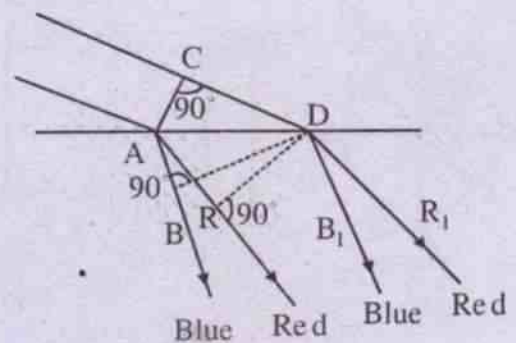

Fig. 14.7 (Wave theory : Dispersion)

AC = Plane wave front of white light.

Let the time taken by light to move from the point C to D = t. During this time (t), the distance travelled by Blue and red light are AB and AR respectively. (These distances are unequal, since the velocity of blue light < vel of red light in glass-medium, as per the findings of the wave-theory of light).

Now BD = wave front of blue light

and AB, DB₁ = Blue rays.

Similarly, DR = wave front of red light

and AR, DR₁ = Red rays.

Thus the white light is dispersed, separating into component colours (Blue ... Red) by the process of refraction.

The process of dispersion has, thus, been explained by wave theory.

(b) Refraction through prism at minimum deviation position :

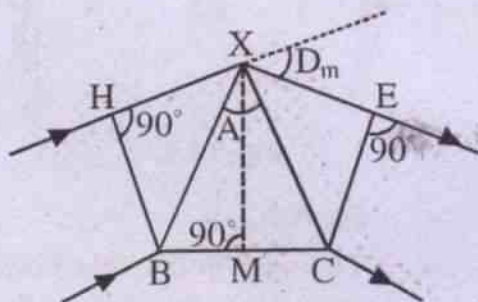

Fig. 14.8

Wave theory : prism at D_m - position

XBC = Principal section of a prism

A = Angle of the prism

BH = Incident wave front

EC = Emergent wave front

HXE = Path of the ray through air

BC = Path of another ray through material of the prism (say, glass)

By wave theory of light:

$${}_a\mu_g = \frac{v_a}{v_g}$$

$$= \frac{v_a \cdot t}{v_g \cdot t}$$

$$= \frac{\text{Distance travelled in air}}{\text{Distance travelled in glass}}$$

$$= \frac{(HX + XE)}{BC}$$

$$= \frac{2HX}{BC} \quad \dots 14.5.1$$

(Minimum Deviation position, being symmetric)

We have

$$\angle HXB + A + \angle CXE + D_m = 180^\circ$$

$$\text{or, } \angle HXB = \frac{180^\circ - (A + D_m)}{2} \quad \dots 14.5.2$$

($\because \angle HXB = \angle CXE$, HB being equal to CE)

$$\text{But } \cos \angle HXB = \frac{HX}{XB}$$

$$\text{so that } XH = (XB) \cos \angle HXB$$

$$= (XB) \cos \left(\frac{180 - (A + D_m)}{2} \right)$$

by eq. 14.5.2

$$= (XB) \sin \frac{A + D_m}{2}$$

$\dots 14.5.3$

$$\text{In the triangle XBM, } \sin A/2 = \frac{BM}{XB}$$

$$\text{so that } BC = 2 BM$$

$$= 2 (XB) \sin A/2 \quad \dots 14.5.4$$

Substituting eqns. 14.5 (3 & 4) in eqn. 14.5.1 :

$$\begin{aligned} \mu_g &= \frac{2(XB) \sin \frac{A+D_m}{2}}{2(XB) \sin A/2} \\ &= \frac{\sin \frac{A+D_m}{2}}{\sin A/2} \quad \dots 14.5.5 \end{aligned}$$

14.6: Interference :

Interference of light is based on the Principle of superposition of waves.

If two light-waves having the same frequency and amplitude with their vibration in phase (i.e. they start from coherent sources) superimpose on each other, then their resultant intensity in the region of superposition is different from the sum of their individual intensities. This modification in the intensity-distribution is called the interference of light.

If the resultant intensity is greater than the sum of the component i.e. individual intensities, then the interference is constructive. However if the resultant or combined intensity is less than the sum of the individual intensities, then there is destructive interference.

14.7: Coherent Sources :

The idea of coherent sources is extremely important for the phenomenon of interference. Suppose we consider a tuning fork as a source of sound. If it is struck, then the entire tuning fork vibrates as a whole (i.e. as one unit - or, bulk phenomenon). Similarly in case of a flute, producing a note, all the air-particles oscillate in the same phase. But this is not so, in case of light-source.

For example, let us consider sodium-vapour lamp. When we supply heat-energy to it, the sodium-vapour inside the lamp gains in energy. Hence the innumerable sodium atoms (about 10^{11} atoms in one cubic-mm-volume) are subjected to energy-gain. These atoms are in excited state - which is unstable and temporary.

They come to the ground or normal state-emitting light-waves in a very small time-span of nearly 10^{-8} second. Since the light-waves are emitted at random by the atoms - independent of each other - (i.e. not in a bulk, as in the case of sound-source), there is no co-ordination between the waves, emitted by them. Such type of waves are said to be incoherent and they cannot produce interference-pattern.

Hence care should be taken for obtaining coherent sources such as : (i) light-source and its image or (ii) two images (real or virtual) of the same source etc.

14.8 : Young's Double slit experiment :

It was performed by the physicist Young in the year 1800 to demonstrate the phenomenon of interference using sunlight.

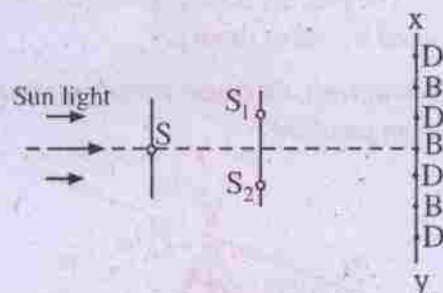

Fig. 14.9

- S = Pin-hole
 S_1, S_2 = Two pin-holes, placed at an appreciable distance from S
 XY = Screen, placed at a good distance from S_1, S_2 .

The space between the stand containing S_1, S_2 and the screen XY is the region of superposition of light-waves, emanating from the pin-holes S_1, S_2 (i.e. two coherent sources)

B = Bright coloured band

D = Dark Band

B and D are produced due to interference of white light coming out of the two coherent sources.

Now-a-days, to improve the experimental set-up, the pin-holes are replaced by two parallel narrow slits (S_1, S_2) and sun-light is replaced by a monochromatic source of light (S), so that the wave fronts are cylindrical.

Theory :

Interference can be analytically explained by the wave-theory of light.

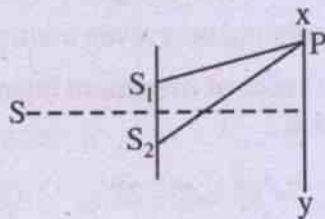

Fig. 14.10

$S_1, S_2 =$ Two very close, parallel slits which are equidistant from the source S . (They act like two coherent sources).

$XY =$ Screen, placed parallel to S_1 and S_2

Let us find out the effect of interference at a point P on the screen XY .

The equation for the light wave starting from S_1 is given by :

$$y_1 = a_1 \sin 2\pi \left(\frac{t}{T} - \frac{S_1P}{\lambda} \right) \quad \dots 14.8.1$$

where $y_1 =$ Displacement at P due to the wave starting from S_1 at time t

$S_1P =$ path of the light from S_1 to P

Similarly the eqn. of light wave starting from S_2 is given by :

$$y_2 = a_2 \sin 2\pi \left(\frac{t}{T} - \frac{S_2P}{\lambda} \right) \quad \dots 14.8.2$$

where $y_2 =$ Displacement at P due to the wave from S_2 at time t

$S_2P =$ path of the light from S_2 to P

We may note that the values of T and λ have not been changed in eqns. 14.8.(1 & 2), since the two waves are derived from two such slits, which originate from the same source. S and hence coherent.

At the point P , the above two waves are superposed. Hence by the principle of superposition, the resultant displacement (y) at P is obtained by :

$$\begin{aligned} y &= y_1 + y_2 \\ &= a_1 \sin \frac{2\pi}{\lambda} \left(\frac{t}{T} - \frac{S_1P}{\lambda} \right) \\ &\quad + a_2 \sin \frac{2\pi}{\lambda} \left(\frac{t}{T} - \frac{S_2P}{\lambda} \right) \end{aligned} \quad \dots 14.8.3$$

Putting $\frac{2\pi}{T} = \omega$

$$\frac{-2\pi}{\lambda} (S_1P) = \alpha_1$$

and $\dots 14.8.4$

$$\frac{-2\pi}{\lambda} (S_2P) = \alpha_2$$

we have from eqn. (14.8.3)

$$\begin{aligned} y &= a_1 \sin(\omega t + \alpha_1) + a_2 \sin(\omega t + \alpha_2) \\ &= a_1 \sin \omega t \cos \alpha_1 + a_1 \cos \omega t \sin \alpha_1 + \\ &\quad a_2 \sin \omega t \cos \alpha_2 + a_2 \cos \omega t \sin \alpha_2 \\ &= \sin \omega t (a_1 \cos \alpha_1 + a_2 \cos \alpha_2) + \\ &\quad \cos \omega t (a_1 \sin \alpha_1 + a_2 \sin \alpha_2) \end{aligned} \quad \dots 14.8.5$$

Put $a_1 \cos \alpha_1 + a_2 \cos \alpha_2 = R \cos \theta$

and $a_1 \sin \alpha_1 + a_2 \sin \alpha_2 = R \sin \theta \dots 14.8.6$

so that eqn. 14.8.5 gives :

$$y = R \sin wt \cos \theta + R \cos wt \sin \theta$$

$$= R \sin (wt + \theta) \quad \dots 14.8.7$$

Eqn. (14.8.7) is the resultant wave equation, which is of Periodic nature with amplitude R. This can be analysed as below :

Resultant Amplitude = R

$$= \sqrt{R^2}$$

$$= \sqrt{R^2(\cos^2 \theta + \sin^2 \theta)}$$

$$= \sqrt{(a_1 \cos \alpha_1 + a_2 \cos \alpha_2)^2 + (a_1 \sin \alpha_1 + a_2 \sin \alpha_2)^2}$$

by eqn. 14.8.6

Hence the resultant intensity = $I = R^2$

$$= (a_1 \cos \alpha_1 + a_2 \cos \alpha_2)^2 + (a_1 \sin \alpha_1 + a_2 \sin \alpha_2)^2$$

$$= a_1^2 + a_2^2 + 2a_1 a_2 (\cos \alpha_1 \cos \alpha_2 + \sin \alpha_1 \sin \alpha_2)$$

$$= a_1^2 + a_2^2 + 2a_1 a_2 \cos(\alpha_1 - \alpha_2) \quad \dots 14.8.8$$

But $\alpha_1 - \alpha_2 = \frac{2\pi}{\lambda}(S_2P - S_1P)$ by eq. 14.8.4

$$= \frac{2\pi}{\lambda} (\text{Path difference})$$

$$= \text{Phase difference (by definition)}$$

$$= \delta \text{ (say)} \quad \dots 14.8.9$$

Substituting this in eqn. 14.8.8,

$$I = a_1^2 + a_2^2 + 2a_1 a_2 \cos \delta \quad \dots 14.8.10$$

Analysis of eqn. (14.8.10) :

Intensity (I) is maximum, when $\cos \delta = +1$

i.e., $\delta = 0, 2\pi, 4\pi, \dots, 2n\pi$ where $n = 0, 1, 2, \dots$

Using eqn. 14.8.9 above,

$$\frac{2\pi}{\lambda} (\text{Path difference}) = 0, 2\pi, 4\pi, \dots, 2n\pi$$

or, Path difference = $0, \lambda, 2\lambda, \dots, n\lambda$

...14.8.11

Thus the condition for maxima (i.e., maximum intensity or bright fringe) is that the path difference should be an even multiple of $\lambda/2$.

The value of maximum intensity can be calculated as :

$$I_{\max} = a_1^2 + a_2^2 + 2a_1 a_2 \quad (\because \cos \delta = 1)$$

$$= I_1 + I_2 + 2a_1 a_2 \quad \dots 14.8.12$$

where I_1 = Intensity of the 1st wave I_2 = Intensity of the 2nd wave

where $I_{\max} >$ Sum of the individual intensities ($I_1 + I_2$) of the two interfering waves.

I is minimum, when $\cos \delta = -1$

i.e., $\delta = \pi, 3\pi, 5\pi, \dots, (2n+1)\pi$

where $n = 0, 1, 2, \dots$

or, $\frac{2\pi}{\lambda} (\text{Path difference}) = \pi, 3\pi, 5\pi, \dots, (2n+1)\pi$

$$\therefore \text{Path difference} = \frac{\lambda}{2}, \frac{3\lambda}{2}, \frac{5\lambda}{2}, \dots, (2n+1)\frac{\lambda}{2}$$

...14.8.13

Thus the condition for minima (i.e., minimum intensity or dark fringe) is that the Path difference should be an odd multiple of $\lambda/2$.

The value of minimum intensity can be calculated as follows :

$$I_{\min} = a_1^2 + a_2^2 - 2a_1 a_2$$

$$= I_1 + I_2 - 2a_1 a_2 \quad \dots 14.8.14$$

Dark fringes (Minima) :

By eq. (14.8.13), condition for the dark fringe is :

$$\begin{aligned} \text{Path difference} &= S_2P - S_1P \\ &= (2n+1)\frac{\lambda}{2} \end{aligned}$$

Equating this with eq. 14.9.3, we get :

$$\frac{2x_n d}{D} = (2n+1)\frac{\lambda}{2}$$

where n = position of the n^{th} dark fringe

$$\therefore x_n = (2n+1)\frac{D\lambda}{4d}$$

$$\text{Similarly } x_{n+1} = (2n+3)\frac{D\lambda}{4d}$$

$$\begin{aligned} \text{Thus } x_{n+1} - x_n &= \frac{D\lambda}{4d} \quad (2) \\ &= \frac{D\lambda}{2d} \quad \dots 14.9.7 \end{aligned}$$

From eqns. 14.9 (6 & 7), we find that the fringe-width (both for the dark and bright fringes) is the same and they are all equispaced.

14.10: Conditions for interference :

Conditions for interference may be covered in three categories :

- conditions for sustained interference
- conditions for observation of fringes
- conditions for good contrast between maxima and minima

(a) Conditions for sustained interference :

They are mainly related to source.

- The sources should be coherent, i.e., they should either vibrate in the same phase or there should be a constant phase difference between them, i.e., δ in eqn. 14.8.10 should be constant with respect to time.
- The sources should emit light of the same frequency.
- If the interfering waves are polarised, they should be in the same state of polarisation.

(b) Conditions for observation of fringes :

- The separation between the two sources ($2d$) should be small (Refer fringe-width eqn. 14.9.6 :

$$w = \frac{\lambda D}{2d} \text{), so that the fringe-width will be large.}$$

- For the above reason, D (= Distance between source and screen) should be large.
- The background should be dark.

(c) Condition for good contrast :

- The amplitude of the interfering waves should be equal or nearly equal, so that the minima will have almost zero light, because

$$\begin{aligned} I_{\min} &= (a_1 - a_2)^2 \\ &= 0 \text{ (if } a_1 = a_2 \text{)} \end{aligned}$$

- Sources must be narrow; otherwise the maxima and minima will overlap and there will be general illumination in place of a fringe-pattern.

- If sources are white or polychromatic, then path difference should be small; otherwise there will be intermixing of colours at any given point in the region of superposition.

SUMMARY

1. Maxwell introduced the idea of displacement current and hence generalised Ampere's law to include time-varying electric field.

There are two possible sources of magnetic field: the conduction current (I) and the displacement current I_d .

2. The existence of electromagnetic wave was proposed by Maxwell and was later realised by Hertz.
3. E.M. waves transverse in nature, with electric and magnetic fields oscillating in mutually perpendicular directions and both being perpendicular to the direction of propagation.
4. These waves do not require a medium for their propagation.
5. In vacuum e.m. waves travel with a speed 'C' where $C = 3 \times 10^8 \text{ ms}^{-1}$

$$C = \frac{E}{B} = \frac{E_0}{B_0} = \frac{1}{\sqrt{\epsilon_0 \mu_0}}$$

6. In any other medium, speed of e.m. wave is $v = \frac{1}{\sqrt{\mu E}}$
7. Average electric and magnetic energy densities are equal to each other.

$$\langle U_E \rangle = \langle U_M \rangle = \frac{1}{4} \epsilon_0 E_0^2 = \frac{1}{4 \mu_0} B_0^2$$

8. Intensity of radiation $I = \frac{1}{2} \epsilon_0 E_0^2 C$

Ex.1: The magnitude of electric field vector (E_0) in an electromagnetic wave is 45π volt/m. Find B_0 and maximum energy density. (Given that

$$C = 3 \times 10^8 \text{ ms}^{-1}, \mu_0 = 4\pi \times 10^{-7} \text{ henry/m})$$

Soln.

$$\frac{E_0}{B_0} = C$$

$$\therefore B_0 = \frac{E_0}{C} = \frac{45\pi}{3 \times 10^8} T = 15\pi \times 10^{-8} \text{ Tebla}$$

$$\text{or } B_0 = 47.1 \times 10^{-8} T.$$

Maximum energy density

$$V_m = \frac{1}{2\mu} B_0^2 = \frac{(15\pi \times 10^{-8})^2}{2 \times 4\pi \times 10^{-7}} \text{ Jm}^{-3}.$$

Ex.2: The frequency range of visible light is from $4 \times 10^{14} \text{ Hz}$ to $7 \times 10^{14} \text{ Hz}$. What is the corresponding wavelength range?

Soln.

We know that $\lambda = \frac{C}{\nu}$ ($\nu \rightarrow$ frequency).

$$\therefore \lambda_1 = \frac{C}{\nu_1} = \frac{3 \times 10^8}{4 \times 10^{14}} \text{ m} = 7.5 \times 10^{-7} \text{ m}$$

$$\lambda_2 = \frac{C}{\nu_2} = \frac{3 \times 10^8}{7 \times 10^{14}} \text{ m} = 4.3 \times 10^{-7} \text{ m}.$$

Ex.3: In an electromagnetic wave, the amplitude of electric field is $E_0 = 150 \text{ NC}^{-1}$. Determine amplitude of magnetic field (B_0), and wavelength λ . [$\nu = 50 \text{ MHz}$].

Soln.

$$\frac{E_0}{B_0} = C$$

$$\therefore B_0 = \frac{E_0}{C} = \frac{150}{3 \times 10^8} = 15\pi \times 10^{-8} \text{ Tebla}$$

$$\text{or } B_0 = 47.1 \times 10^{-8} T.$$

Maximum energy density

$$U_m = \frac{1}{2\epsilon_0} B_0^2 = \frac{(15\pi \times 10^{-8})^2}{2 \times 4\pi \times 10^{-7}} Jm^{-3}$$

$$U_m = 8.83 \times 10^{-8} Jm^{-3}$$

Ex.4: The frequency range of visible light is from 4×10^{14} Hz to 7×10^{14} Hz. What is the corresponding wavelength range?

Soln.

$$\text{We know that } \lambda = \frac{C}{\nu} \quad (\nu \rightarrow \text{frequency})$$

$$\therefore \lambda_1 = \frac{C}{\nu_1} = \frac{3 \times 10^8}{4 \times 10^{14}} m = 7.5 \times 10^{-7} m$$

$$\lambda_2 = \frac{C}{\nu_2} = \frac{3 \times 10^8}{7 \times 10^{14}} m = 4.3 \times 10^{-7} m$$

Ex.5: In an electromagnetic wave, the amplitude of electric field is $E_0 = 150 NC^{-1}$. Determine amplitude of magnetic field (B_0), and wavelength λ . [$\nu = 50 MHz$].

Soln.

$$B_0 = \frac{E_0}{C} = \frac{150}{3 \times 10^8} = 5 \times 10^{-7} T$$

$$\lambda = \frac{C}{\nu} = \frac{3 \times 10^8}{50 \times 10^6} = 6.0 m$$

Ex.6: In a plane electromagnetic wave, the amplitude of the magnetic field is $5.0 \times 10^{-6} T$. Find the total average energy density. ($\epsilon_0 = 8.854 \times 10^{-12} C^2 N^{-1} m^{-2}$)

Soln.

$$\text{Total average energy density } \nu = \frac{1}{2} \epsilon_0 E_0^2$$

$$\text{Now } E_0 = B_0 C = (5.0 \times 10^{-6}) \times (3 \times 10^8) \nu m^{-1}$$

$$\text{or } E_0 = 1.5 \times 10^3 \nu m^{-1}$$

$$\therefore \nu = \frac{1}{2} (8.85 \times 10^{-12}) (1.5 \times 10^3)^2 = 9.96 \times 10^{-4} Jm^{-2}$$

Ex.7: Light with an energy flux of 20 watt/cm² falls on a non-reflecting surface at normal incidence. Find total momentum delivered to the surface in half an hour if the surface area is 20 cm².

Soln. Total energy falling on the surface is

$$V = (20 \frac{\text{watt}}{\text{Cm}^2}) \times (20 \text{Cm}^2) \times (30 \times 60 \text{s})$$

$$V = 7.2 \times 10^5 J$$

$$\text{Momentum } P = \frac{V}{C} = \frac{7.2 \times 10^5}{3 \times 10^8} \text{ kgms}^{-1}$$

$$\text{or } P = 2.4 \times 10^{-3} \text{ kgms}^{-1}$$

Ex.7: The electric field in an e.m. wave is given

$$\text{by } E = (20 NC^{-1}) \sin \omega(t - \frac{x}{C}).$$

Find the intensity of the wave.

$$(\epsilon_0 = 8.85 \times 10^{-12} C^2 N^{-1} m^{-2})$$

Soln.

$$I = 53.1 \times 10^{-2} Wm^{-2}$$

Multiple Choice Questions

- The amplitudes of electric and magnetic fields are related to each other by the relation:
 - $E_0 = B_0 C$, b) $B_0 = E_0 C$,
 - $E_0 B_0 = C^2$ d) $E_0 B_0 = C$.
- The direction of propagation of electromagnetic wave is:
 - \vec{E} , b) \vec{B} c) $\vec{E} \times \vec{B}$ d) $\vec{E} \cdot \vec{B}$
- The phase difference between \vec{E} and \vec{B} in an electromagnetic wave is:
 - 0, b) π c) $\frac{\pi}{4}$ d) $\frac{\pi}{2}$
- The maximum electric field intensity in an electromagnetic wave is $E_0 = 1.8 \times 10^{-1} \text{Vm}^{-1}$. What is the maximum magnetic flux density B_0 ?
 - $\frac{1}{2E_0} E_0^2$, b) $2E_0 E_0^2$,
 - $\frac{E_0}{2} E_0^2$ d) $\frac{1}{2} E_0 E_0^2$
- The electric field amplitude of an electromagnetic wave is E_0 . The energy density is:
 - $\frac{1}{2} E_0^2$, b) $2E_0 E_0^2$,
 - $\frac{E_0}{2} E_0^2$ d) $\frac{1}{2} E_0 E_0^2$
- When a plane electromagnetic wave enters from one medium to another, which of the following remains unchanged?
 - wavelength, b) frequency
 - velocity d) None of these
- Which of the following has the longest wave length?
 - X-rays b) infrared
 - radio waves d) ultraviolet waves
- Which of the following e.m. waves are used in telecommunications?
 - Infrared b) x-rays,
 - microwaves d) ultraviolet
- The speed of electromagnetic wave in vacuum is
 - $\frac{1}{\mu_0 \epsilon_0} E_0$ b) $\frac{1}{\sqrt{\mu_0 \epsilon_0} E_0}$ c) $\frac{E_0}{\mu_0}$ d) $E_0 \mu_0$
- Which of the following length frequency?
 - microwaves, b) ultraviolet
 - x-rays d) visible light.
- What is the dimensions of $\frac{1}{\mu_0 \epsilon_0} E_0$.
 - L^2T^2 , b) L^2T^{-2}
 - L^2T^2 d) L^2T^{-2}

Answer: 1.(a), 2(c), 3.(a), 4.(a), 5(d), 6(b), 7(c), 8(c), 9.(b), 10(a), 11(c)

14.11 Diffraction:

The phenomenon of bending of light round the corner of an obstacle when light wave is incident on it, is called the *diffraction*.

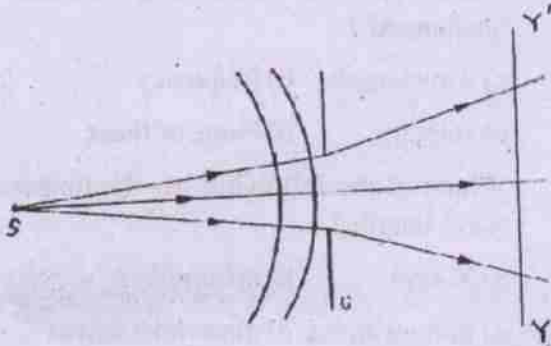

Fig. 14.12

We can explain this phenomenon using Huygens' Principle. When a wavefront is partially obstructed, only the secondary wavelets from the exposed parts superpose and the resulting wavefront has a different shape. This allows for the bending round the edges. In case of light waves, beautiful fringe patterns comprising maximum and minimum intensity are formed due to diffraction.

Fig. 14.12 shows the basic arrangements for observing diffraction effects in light waves. It consists of a source 'S' an opening (/obstacle) 'G' and a screen 'YY'. The secondary wavelets originating from points of the obstructed part interfere on the screen 'YY' and produce the diffraction pattern of varying intensity.

Diffraction is of two types:

(i) **Fraunhofer type:-** When both the source and screen are far away from the diffracting element G, the corresponding diffraction pattern is called Fraunhofer diffraction. Fraunhofer diffraction can be observed in laboratory by placing converging lenses before and after G and keeping the source and screen in their focal planes as shown below in fig. 14.13.

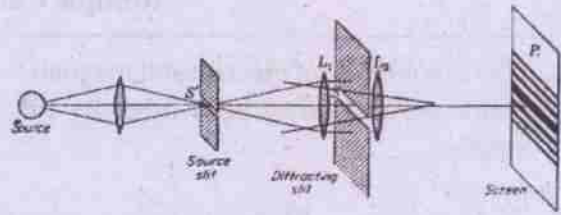

Fig. 14.13

The sources and the screen are effectively at infinite from the diffracting element.

(ii) **Fresnel type:-** When the source or the screen are at finite distance from the diffracting element G, the corresponding diffraction pattern is called Fresnel diffraction.

However for sake of simplicity we shall limit our discussion to Fraunhofer diffraction and at the end we shall give a short remark on the Fresnel diffraction as it is more involved and beyond the scope of this book.

14.11(A) Fraunhofer diffraction by a single slit:-

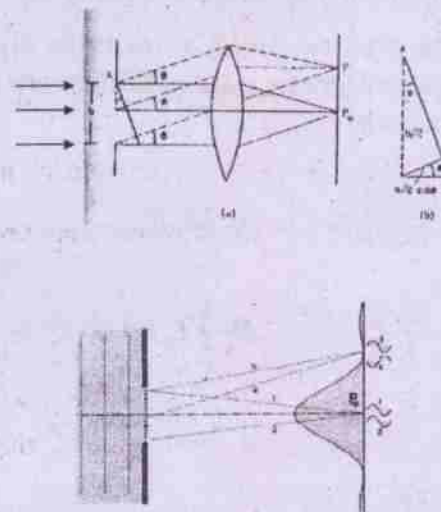

Fig. 14.14(b)

Suppose a parallel beam of light is incident normally on a slit of width 'b'. As per Huygens' postulate each and every point of the slit acts as a source of secondary wavelets spreading in all directions. This light falls on a convergent lens which focuses it on a screen

YY' placed in the focal plane of the lens. All these secondary waves start parallel to each other from different points of the slit and interfere at P to give the resultant intensity.

Now consider the intensity pattern points of the screen. At the point P_0 which is at the perpendicular bisector of the slit (see fig. 14.14) all the waves reach after travelling equal optical path and hence are in phase. The waves thus interfere constructively with each other and maximum intensity is observed at P_0 . As we move away from P_0 the waves arrive with different phases and thus the intensity is changed.

Let us consider a point P where the rays leaving the slit making an angle θ (as shown in fig.14.14) meet. The perpendicular from the edge A to the parallel rays represents the wavefront of the parallel beam diffracted from the slit at an angle θ . Hence the optical path from any point on the wavefront AN to the point p is same. Therefore the optical path difference ' Δ ' between the wave leaving edge A and the wave leaving the midpoint 'M' of the slit is $\frac{b}{2} \sin \theta$ (see fig. 14.14(b)). Then the phase difference between these two waves shall be

$$\delta = \frac{2\pi}{\lambda} \Delta = \frac{2\pi}{\lambda} \left(\frac{b}{2} \sin \theta \right) \quad \text{---(14.11.1)}$$

If the angle θ is such that $\frac{b}{2} \sin \theta = \lambda/2$; then the phase difference

$$\delta = \frac{2\pi}{\lambda} \cdot \frac{\lambda}{2} = \pi \quad \text{---(14.11.2)}$$

Hence these two waves shall interfere destructively and the intensity shall be minimum (zero) here. Thus when $\frac{b}{2} \sin \theta = \lambda/2$; implying $b \sin \theta = \lambda$, we get

the first minimum. Similar considerations imply that whenever $b \sin \theta = 2\lambda, 3\lambda$ or $b \sin \theta = n\lambda$ (dark fringe) ---(14.11.3)

Dark fringers (minima) shall be obtained. On the other hand whenever for a point on the

screen $\frac{b}{2} \sin \theta = n\lambda$, so that phase difference,

$$\delta = \frac{2\pi}{\lambda} n\lambda = 2n\pi, \text{ there shall be constructive}$$

interference and there shall be maximum. But the intensities shall be different. These points lie midway between the minima. Points equidistant from the center will also satisfy the above conditions. A detailed mathematical analysis shows that the amplitude E'_0 of the electric component of the e.m. wave representing the light, at a general point P is given as

$$E'_0 = E_0 \frac{\sin \beta}{\beta} \quad \text{---(14.11.4)}$$

Where $\beta = \frac{\pi}{\lambda} b \sin \theta$ and E_0 is the amplitude at the point P_0 ; which corresponds to $\theta = 0$.

As the intensity is proportional to the square of the amplitude so the intensity at any point P is given by **intensity function**

$$I_p = I_0 \frac{\sin^2 \beta}{\beta^2} \quad \text{---(14.11.5)}$$

So the maximum or minimum is given by

$$\frac{dI_p}{d\beta} = 0$$

This gives: $\sin \beta = 0$ or $\beta = \tan \beta$. Taking second derivative one finds if $\sin \beta = 0$, I_p will be minimum and if $\beta = \tan \beta$ then I_p will be maximum. This can be seen from the graphs given below.

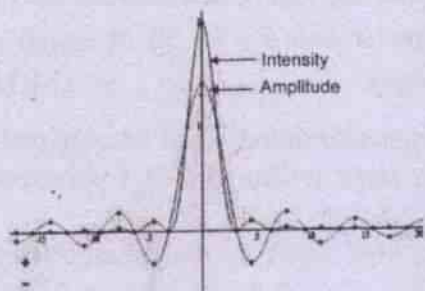

Fig.14.15(a)

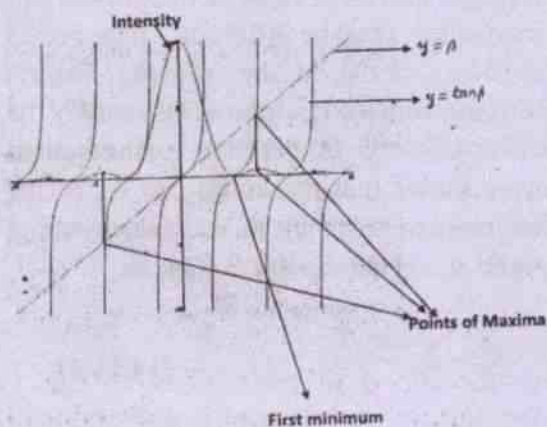

Fig. 14.15(b)

Actual Calculation shows that for

$\beta = 0, \quad I_p = I_0 = \text{central maximum intensity}$

$\beta = 1.430\pi, \quad I_p = 0.0496 I_0 = 4.96\% \text{ of central maximum intensity}$

$\beta = 2.459\pi, \quad I_p = 0.0168 I_0 = 1.68\% \text{ of central maximum intensity}$

Width of Central maximum:

The fig. 11.16 gives a picture of central maximum.



Fig. 14.16

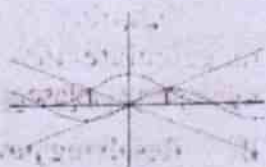

Fig. 14.17

In order to get an idea about the width of central maximum we need to obtain the half width (the separation between the points of half intensity maximum) which gives

$$\frac{1}{2} = \frac{I_p}{I_0} = \frac{\sin^2 \beta}{\beta^2} \Rightarrow \sin \beta = \pm \frac{1}{\sqrt{2}} \beta \quad \text{---(14.11.6)}$$

Equation 14.11.6 is a transcendental equation and is solved graphically as shown above. Fig.11.17 shows that for $\beta = \pm 0.443\pi$ the intensity is half of the maximum. hence half width $Hw = 0.886 \pi$. The above solution shows that the half-width depends on the slit width since

$$\beta_1 = \frac{\pi b \sin \theta_1}{\lambda} = 0.443\pi$$

$$\Rightarrow \sin \theta_1 = 0.443 \frac{\lambda}{b}$$

So if b , the width of the slit increases then θ_1 decreases which implies the intensity decreases to half its maximum value at a smaller value of β . Thus when the slit width increases the intensity curve becomes sharper. The angular width of central maximum is defined by

$$\sin \theta_{\pm 1} = \pm \frac{\lambda}{b}$$

For $b \gg \lambda$; angular width $\Delta\theta = 2 \frac{\lambda}{b}$.

Fig.14.18 and 19 clearly illustrate this feature.

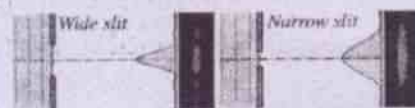

Fig. 14.18

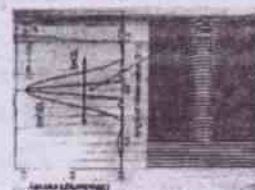

Fig. 14.19

Ex.14.5: A parallel beam of green light of wavelength 546 nm passes through a slit of width 0.40mm. The transmitted light is collected on a screen at a distance of 40 cm. Find the separation between the two first order minima.

Soln. Given

$$\text{wavelength of light} = \lambda = 546 \times 10^{-9} \text{ m}$$

$$\text{slit width} = b = 0.40 \text{ mm} = 4 \times 10^{-4} \text{ m}$$

$$\text{Distance of the screen} = D = 40 \text{ cm} = 0.4 \text{ m}$$

For minimum to occur we have $b \sin \theta = n\lambda$

For first order minima, $n=1$, giving $\sin \theta = \pm \frac{\lambda}{b}$

As the fringes are obtained at a large distance $D \gg b$, so the linear distance x from the central maximum is given as

$$\frac{x}{D} = \tan \theta \cong \sin \theta.$$

This gives $x = D \sin \theta = D \left(\pm \frac{\lambda}{b} \right) = \pm \frac{\lambda D}{b}$

Hence the separation between the two 1st order

minima is $\frac{2\lambda D}{b}$.

Now it is calculated to be

$$\frac{2\lambda D}{b} = \frac{2 \times 546 \times 10^{-9} \text{ m} \times 0.4 \text{ m}}{4 \times 10^{-4} \text{ m}} = 1.1 \times 10^{-3} \text{ m}$$

Ex.14.6: Plane microwaves are incident on a long slit having a width of 5.0cm. Calculate the wavelength of the microwaves if the first diffraction minimum is formed at $\theta = 30^\circ$.

Solution:

$$\text{Given slit width} = b = 5.0 \text{ cm} = 5 \times 10^{-2} \text{ m}$$

For 1st minimum to occur we have

$$b \sin \theta = \lambda$$

Since $\theta = 30^\circ$, so

$$5 \times 10^{-2} \times \sin 30^\circ = \lambda = 2.5 \times 10^{-2} \text{ m}$$

i.e. $\lambda = 2.5 \text{ cm}$

14.12 Resolving Power:-

Resolving Power is the ability of an imaging device to separate (i.e. to see as distinct) points of an object that are located at a small angular distance or it is the power of an optical instrument to separate far away objects, that are close together, into individual images. The term **resolution** or **minimum resolvable distance** is the minimum distance between distinguishable objects in an image, although the term is loosely used by many users of microscope and telescopes to describe resolving power.

The imaging system's resolution can be limited either by **aberration** or by **diffraction** causing blurring of the image. These two phenomenon have different origins and are unrelated. **Aberrations** can be explained by geometrical optics and can in principle be reduced by increasing the optical quality. On the other hand, **diffraction comes from the wave nature of light and is determined by the finite aperture of the optical elements.**

The interplay between diffraction and aberration can be characterised by the **point spread function (PSF)**. *The narrower the aperture of a lens the more likely the PSF is dominated by diffraction.* In that case, the angular resolution of an optical system can be estimated by the **Rayleigh criterion**.

A. Rayleigh Criterion:-

Rayleigh proposed that "two point sources are regarded as just resolved when the principal diffraction maximum (central maximum) of one image coincides with the first minimum of the other and vice-versa".

This criterion can be conveniently applied to calculate the resolving power of a microscope, telescope, prism grating, etc.

B. Resolving power of Microscope:-

In this case the effects due to diffraction can be accounted for by considering a plane

wave incident on a circular aperture. The analysis of diffraction due to a circular aperture shows that the resulting diffraction pattern consists of a central bright region surrounded by concentric dark and bright rings. A detailed analysis* as given below may be seen for sake of complete knowledge. In case of microscope the object is very near the objective of the microscope and the objects subtend very large angle at the objective. The limit of resolution of a microscope is determined by the the least permissible linear distance between the two objects so that the two images are just resolved.

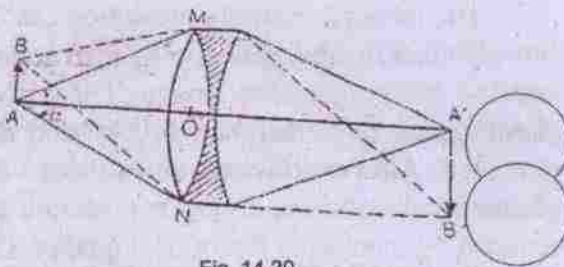

Fig. 14.20

In the above figure MN is the aperture of the objective of a microscope and A and B are two object points at a distance 'd' apart. A' is the position of the central maximum of A and B' is the central minimum of B. A' and B' are surrounded by alternate dark and bright diffraction rings.

The path difference between extreme rays from the point B and reaching A' is given by

$$\Delta = (BN + NA') - (BM + MA')$$

But since $NA' = MA'$, so $\Delta = (BN - BM)$

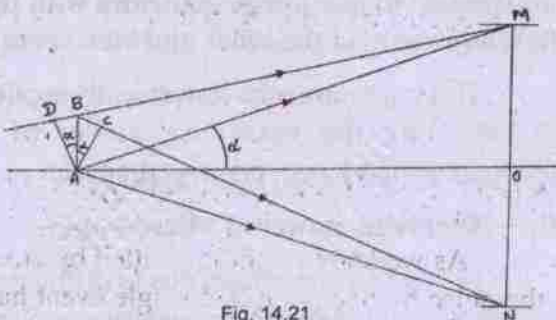

Fig. 14.21

In fig.14.21 AD is perpendicular to DM and AC is perpendicular to BN.

Therefore,

$$\Delta = BN - BM = (BC + CN) - (DM - DB) \quad \text{----(14.12.2)}$$

But $CN = AN = AM = DM$; therefore,

$$\Delta = BC + DB \quad \text{----(14.12.3)}$$

From triangles ACB and ADB

$$BC = AB \sin \alpha = s \sin \alpha \quad \text{and}$$

$$DB = AB \sin \alpha = s \sin \alpha$$

This gives $\Delta = 2s \sin \alpha \quad \text{----(14.12.4)}$

If this path difference $\Delta = 2s \sin \alpha = 1.22\lambda$ then A' corresponds to the first minimum of image B' and two images are just resolved. Therefore,

$$2s \sin \alpha = 1.22\lambda$$

$$s = 1.22\lambda / (2 \sin \theta) \quad \text{----(14.12.5)}$$

where 's' is the resolvable separation between objects points A and B and ' α ' is half the angle subtended at the axial point object A by the rim of the microscope objective, and ' λ ' is the wavelength of light in vacuum. It is to be noted that the entire path difference $\Delta = BN - BM$ is in the medium between the object and objective.

The product of the index of refraction of medium in which the object is situated and sine of half angle of the cone of rays admitted by the objective i.e. $\mu \sin \alpha$ was called by Abbe the *numerical aperture of the objective (NA)* and eqn. 14.12.5 reduces to

$$s = (1.22\lambda) / (2\mu \sin \theta) \quad \text{----(14.12.6)}$$

For air upper limit of NA of the microscope objective is about 0.9. Therefore with white light of effective wavelength 5600×10^{-8} cm the least resolvable distance in air is

$$S_{\text{air}} = \frac{1.22 \times 5600 \times 10^{-8}}{2 \times 0.95} = 3.6 \times 10^{-5} \text{ cm}$$

But if the space between object and objective is filled by oil, then NA is increased to 1.6. Hence the least resolvable distance becomes.

$$S_{oil} = \frac{1.22 \times 5600 \times 10^{-8}}{2 \times 1.6} = 2.14 \times 10^{-5} \text{ cm}$$

Thus the resolving power of an oil immersion type objective is approximately twice that of the ordinary objective.

C. Resolving power of Astronomical Telescope:

The astronomical telescope is employed to view distant objects and therefore the amount of detail which it reveals depends on the angle the two point objects subtend at the objective rather than on the linear separation between them. Thus "*Resolving power of an astronomical telescope is therefore defined as the inverse of the least angle subtended at the objective by the two distant point objects which can be just distinguished as separate in its focal plane*".

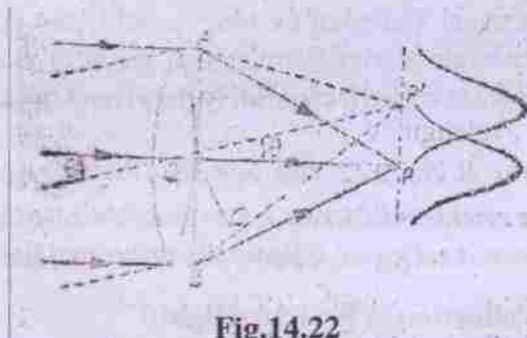

Fig.14.22

Let 'a' be the diameter of the objective of the telescope considering the incident ray of light from two neighbouring points of a distant object. The image of each point object is a Fraunhofer diffraction pattern. Let P and P' be the position of the central maximum of two images. These two images are resolved if the position of the central maximum of second image coincides with the first minimum of the first image and vice-versa. The path difference between the secondary waves travelling in the direction AP and BP is low and hence they reinforce with

one another at P. The secondary waves travelling in the direction AP' and BP' will meet at P' on the screen. Let the angle $\angle P'AP$ be $d\theta$. The path difference (Δ) between the secondary waves travelling in the directions BP' and AP' is equal to BC. Therefore,

$$\Delta = BC = AB \sin d\theta = AB d\theta = a d\theta$$

If the path difference $\Delta = a d\theta = \lambda$, then the position P corresponds to the first minimum of the first image. But P is also the position of the central maximum of the second image. Thus Rayleigh's criterion of resolution is satisfied if

$$a d\theta = 1.22\lambda \text{ or } d\theta = 1.22\lambda / a \quad \text{---(14.12.8)}$$

The reciprocal of $d\theta$ i.e. $1/d\theta$ is a measure of the resolving power of the telescope (R.P. Telescope). Thus

$$\text{R. P. Telescope} = 1/d\theta = a/[1.22\lambda]$$

$$\text{---(14.12.9)}$$

14.13 Polarisation:

From our knowledge of electromagnetic (e.m.) wave, suggested by Maxwell, the electric field vector \vec{E} and magnetic field vector \vec{B} are perpendicular to each other and perpendicular to the direction of propagation of electromagnetic wave. The electric field vector \vec{E} represents the light characteristics. So for an e.m. wave travelling in Z - direction, the electric field vector \vec{E} and magnetic field vector \vec{B} can be represented as

$$E_x = E_0 \cos(kz - \omega t); E_y = 0, E_z = 0 \quad (14.13.1)$$

$$B_x = 0, B_y = B_0 \cos(kz - \omega t); B_z = 0 \quad (14.13.2)$$

$$\text{where, } k = \omega/v = \omega\sqrt{\mu\epsilon}, v = 1/\sqrt{\mu\epsilon} \quad (14.13.3)$$

As we know, light is emitted by atoms. the pulse by one atom in a single event has a

fixed direction of electric field. However light emitted by different atoms, in general have electric field in different directions. The coherence time is $\sim 10^{-8}$ s, so while the individual wave train oscillates in some constant mode and direction, the modes and directions of oscillations vary from wave train to wave train. Hence the resultant electric field \vec{E} at a point keeps on changing its direction rapidly and randomly. Such a light is called **unpolarized**. The light emitted by an ordinary source such as electric lamp, a mercury tube; a candle, the sun etc., are unpolarized.

Suppose an unpolarized light wave travels along the Z-axis. The electric field at any instant is in the X-Y plane. We can break the field into its components E_x and E_y , along the X-axis and the Y-axis respectively. The fact that the resultant electric field changes its direction randomly may be mathematically expressed by saying that E_x and E_y have a phase difference δ that changes randomly with time. Thus,

$$E_x = E_1 \sin[\omega t - kz + \delta(t)] \quad \text{---(14.13.4)}$$

$$E_y = E_2 \sin[\omega t - kz] \quad \text{---(14.13.5)}$$

The resultant electric field makes an angle ... with the X-axis where

$$\tan \theta = \frac{E_y}{E_x} = \frac{E_2 \sin[\omega t - kz]}{E_1 \sin[\omega t - kz + \delta(t)]} \quad \text{---(14.13.6)}$$

Since $\delta(t)$ changes rapidly with time, so θ changes rapidly and thus light is unpolarized. Now we consider three possible cases as given below:

(i) If $\tan \theta = E_2 / E_1 = \text{constant}$ and the electric field is always parallel to a fixed direction. Then we say that the light is **linearly polarized or plane polarized**; because now the electric field vector is confined to X-Y plane

and parallel to a fixed direction.

(ii) If $\delta = \pi$, $\tan \theta = -E_2 / E_1$ and again the electric field is always parallel to a fixed direction. Then again we say that the light is **linearly polarized**.

(iii) If $\delta = \pi/2$ and $E_1 = E_2$,

then

$$\tan \theta = \frac{E_y}{E_x} = \frac{E_2 \sin[\omega t - kz]}{E_1 \sin[\omega t - kz + \pi/2]} = \tan(\omega t - kz)$$

$$\Rightarrow \theta = \omega t - kz \quad \text{---(14.13.7)}$$

This eqn. 14.13.7 shows that at any point z, the angle θ increases at a uniform rate ω . The electric field, therefore, rotates at a uniform angular speed ω . Also

$$E^2 = E_x^2 + E_y^2 = E_1^2 \cos^2(\omega t - kz) + E_1^2 \sin^2(\omega t - kz) = E_1^2$$

i.e. the magnitude of the electric field remains constant. The tip of the electric field, thus goes in a circle at a uniform angular speed ω . Such a light is called a **circularly polarized light**.

(iv) If $\delta = \pi/2$ and $E_1 \neq E_2$, then the tip of the electric field traces out an ellipse. such a light wave is called an **elliptically polarized light**.

Production of Polarized light:

A. Using Polaroid: An instrument used to produce polarized light is called a polarizer. Thin plastic like plane sheets in the shape of circular discs called polaroids, are commercially available which transmit light with electric field vector parallel to a special direction in the sheet. These polaroids have long chain of hydrocarbons which become conducting at optical frequencies. When light falls perpendicularly on the sheet the electric vector component parallel to the chains is absorbed in setting up electric currents in the chains. But

the electric field component perpendicular to the chains get transmitted. The direction perpendicular to the chain is called the transmission axis or pass axis of the polaroid. **When light passes through the Polaroid, the transmitted light becomes linearly polarized with electric field vector parallel to the transmission axis.** But the intensity is reduced by half (of unpolarized light).

If the linearly polarized light is incident on a Polaroid with electric field vector parallel to the transmission axis, the light is transmitted with constant intensity. But if the linearly polarised light is incident on a Polaroid with electric field vector perpendicular to transmission axis then light is completely stopped. If the linearly polarized light is incident on a Polaroid with electric field vector making an angle θ with the transmission axis, then the light is partially transmitted. The intensity of the transmitted light is given as

$$I = I_0 \cos^2 \theta \quad \text{----(14.13.8)}$$

Where I_0 is the intensity of the polarized light before passing through the second polaroid. This is known as Malus' law (or law of Malus).

The above discussion shows that the intensity coming out of a single Polaroid is half the incident intensity. By putting second Polaroid, the intensity can be further reduced (even to zero of the incident intensity). Polaroids are used in sunglasses, windowpanes, etc.

B. Polarisation by reflection:

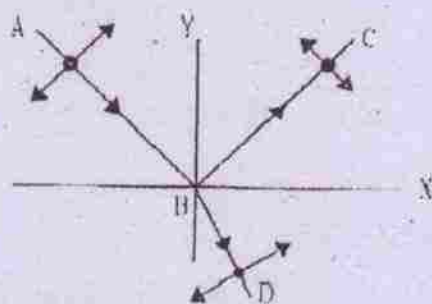

Fig.14.23

Consider a light beam from air incident on a transparent medium of refractive index μ . As per laws of reflection the incident ray, the reflected ray and the refracted ray lie on one plane, the plane of incidence. In the above figure (14.23) the plane of incidence is chosen to be X-Y plane. Let the incident light go along AB. The electric field vector \vec{E} (representing the light must be perpendicular to AB. If the incident light is unpolarized, then \vec{E} will randomly change its direction, remaining at all times in a plane perpendicular to AB. We can resolve the field \vec{E} into two components, one in the $\overline{X-Y}$ plane and the other along the Z-direction. In fig.14.23.1 the component in the X-Y plane is shown by double-headed arrow perpendicular to AB and the component along the Z-direction by the solid dot.

Light with \vec{E} along Z-direction is more strongly reflected as compared to light in the X-Y plane. This is indicated by reduced size of the double-arrow. The reflected light has a larger component in the X-Y plane, indicated by reduced size solid dot.

If the light is incident on the surface at an angle of incidence i_p satisfying

$$\tan i_p = \mu \quad \text{-----(14.13.9)}$$

then the reflected light is completely polarized along the Z-direction as shown in fig.14.24. This implies that the angle between incident ray and reflected ray is $\pi/2$.

The refracted light is never completely polarized. The angle i_p satisfying eqn.14.13.9

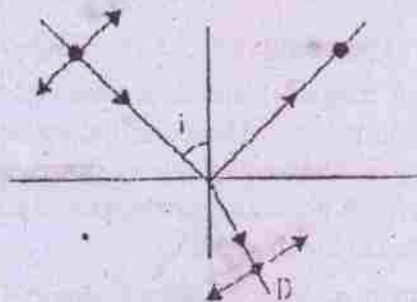

Fig.14.24

is called Brewster's angle and eqn. 14.13.9 is called **Brewster's law**.

14.14. Electromagnetic Waves & Spectrum :

Electrostatics and magnetostatics deal with electric and magnetic phenomena, independent of each other. But if the field quantities depend upon time (i.e. if they change with time), their independence vanishes. A time varying magnetic field gives rise to an electric field and vice versa. These two fields which are interdependent can then be called electromagnetic field.

The behaviour of time dependent electromagnetic fields is described by a set of four equations called maxwell's equations. We will study these equations in our higher classes because of the mathematics involved in it.

The most important application of maxwell's equations is the development of the theory of electromagnetic wave, which propagates due to the combined effect of mutually perpendicular electric and magnetic field*. This theory received wide acceptance only when Hertz, experimentally demonstrated the existence of electromagnetic wave by oscillating electric and magnetic fields. Hertz also demonstrated that the electromagnetic wave like light could be refracted, diffracted and polarised. Since polarisation is the exclusive properties of transverse waves, it was established that electromagnetic wave is transverse in nature. The electric and magnetic fields are perpendicular to each other and both are perpendicular to the direction of propagation.

[[↓] The frequency of oscillation of electric and magnetic fields is same as the frequency of the wave. These oscillating fields generate each other and wave is propagated oscillating fields generate each other and wave is propagated in the medium*.]

In fact no material medium is required for its propagation. The e.m. wave can travel through vaccum.

Let us consider an electromagnetic wave propagating along X-direction. The electric field \vec{E} and magnetic field \vec{B} are along Y and Z-directions respectively. This is shown in the figure below.

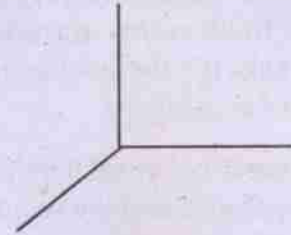

We can represent the electric and magnetic field as:

$$\vec{E} = E_0 \sin \omega(t - \frac{x}{c}) \hat{j} \dots\dots\dots(1)$$

$$\text{and } \vec{B} = B_0 \sin \omega(t - \frac{x}{c}) \hat{k} \dots\dots\dots(2)$$

where E_0 and B_0 are the amplitudes of electric field \vec{E} and magnetic field \vec{B} respectively.

The magnitudes of \vec{E} and \vec{B} are related by

$$\frac{E}{B} = C \quad \text{or} \quad \frac{E_0}{B_0} = C \dots\dots\dots(3)$$

where 'C' is the speed of elecromagnetic wave in vaccum.

It can also be proved that 'C' is related to permittivity ϵ_0 and permability μ in empty space by

$$C = \frac{1}{\sqrt{\mu_0 \epsilon_0}} \dots\dots\dots(4)$$

using the values of $\mu_0 (= 4\pi \times 10^{-7} \text{ NS}^2\text{C}^{-2})$ $\mu_0 (= 8.854 \times 10^{-12} \text{ C}^2\text{N}^{-1}\text{m}^{-2})$ we can see that $C = 2.99 \times 10^8 \text{ ms}^{-1}$.

This is same as the speed of light in vacuum as measured experimentally. Thus light is an electromagnetic wave.

For any other medium the speed of electromagnetic wave is

$$C = \frac{1}{\sqrt{\mu \epsilon}} \dots\dots\dots(5)$$

Energy density and intensity of radiation :

Electromagnetic waves carry energy and momentum. the electric and magnetic energy densities are given by

$$U_E = \frac{1}{2} \epsilon_0 E^2 \dots\dots\dots(6a)$$

$$\text{and } U_m = \frac{1}{2\mu} B^2 \dots\dots\dots(6b)$$

Using the expression for E and b (equations (1) and (2))

$$U_E = \frac{1}{2} E_0^2 \sin^2 \omega(t - \frac{x}{c})$$

$$\text{and } U_m = \frac{1}{2\mu} B_0^2 \sin^2 \omega(t - \frac{x}{c}).$$

Taking time average of these energy densities.

$$\begin{aligned} \langle U_E \rangle &= \frac{1}{2} \epsilon_0 E_0^2 \cdot \frac{\int_0^T \sin^2 \omega(t - \frac{x}{c}) dt}{\int_0^T dt} \\ &= \frac{1}{2} \epsilon_0 E_0^2 \cdot \frac{1}{T} \int_0^T \sin^2 \omega(t - \frac{x}{c}) dt \\ \langle U_E \rangle &= \frac{1}{4} \epsilon_0 E_0^2 * \dots\dots\dots(7a) \end{aligned}$$

$$\text{similarly } \langle U_m \rangle = \frac{1}{4\mu} B_0^2 \dots\dots\dots(7b)$$

$$* \int_0^T \sin^2 \omega(t - \frac{x}{c}) dt = \frac{1}{2} [t - \frac{\sin 2\omega(t - \frac{x}{c})}{2\omega}]_0^T = \frac{1}{2} T$$

$$\int_0^T \cos 2\omega(t - \frac{x}{c}) dt \text{ being zero.}$$

$$\text{Total energy density } \langle U \rangle = \langle U_E \rangle + \langle U_m \rangle$$

$$\text{or } \langle U \rangle = \frac{1}{4} \epsilon_0 E_0^2 + \frac{1}{4\mu} B_0^2 \dots\dots\dots(8)$$

Now using equation (3):

$$B_0 = \frac{E_0}{C}$$

and using equation (4)

$$N_0 \epsilon_0 = \frac{1}{C^2} \text{ or } \frac{1}{N_0} = \epsilon_0 C^2.$$

Then from eqn. (7b)

$$\langle U_m \rangle = \frac{1}{4\mu} B_0^2 = \frac{1}{4} \epsilon_0 C^2 \cdot \frac{E_0^2}{C^2} = \frac{1}{4} \epsilon_0 E_0^2 = \langle U_E \rangle \dots\dots\dots(9)$$

Thus time averaged electric and magnetic energy densities are equal to each other. Then from equation(8)

$$\begin{aligned} \langle U \rangle &= \frac{1}{4} \epsilon_0 E_0^2 + \frac{1}{4} \epsilon_0 E_0^2 \\ \text{or } \langle U \rangle &= \frac{1}{2} \epsilon_0 E_0^2 = \frac{1}{2\mu} B_0^2 \dots\dots\dots(10) \end{aligned}$$

Intensity of radiation is the energy crossing per unit area in unit time.

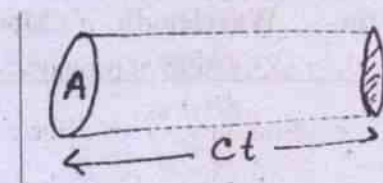

Figure...

Let us consider a cylinder of cross sectional 'area 'A' held perpendicular to the direction of propagation. The energy contained in the cylinder is

$$U = \text{energy density} \times \text{volume}$$

or $U = \langle u \rangle \times (c\Delta t)A$.

This is same as the energy crossing the area 'A' in time Δt . Then as per definition, intensity of energy is

$$I = \frac{U}{A\Delta t} = \frac{\langle u \rangle c\Delta t A}{A\Delta t} = \langle u \rangle C$$

Using eqn. (10) $I = \frac{1}{2} \epsilon_0 C^2 E_0^2$ (11)

Use linear momentum carried by the electromagnetic wave is

$$P = \frac{U}{C} \text{(12)}$$

Where U is the total energy falling on surface.

Electromagnetic spectrum :

Maxwells equations are applicable to e.m. waves of all frequencies. We are all familiar with visible light which is recognised as an electromagnetic wave having wavelength range $4 \times 10^{-7}m$ to $7.8 \times 10^{-7}m$. This forms a small part of a wide spectrum comprising of x-rays, γ -rays, radiowaves, microwaves etc; of different wavelength ranges. We can arrange all such e.m. waves in ascending or descending orders of wavelengths or frequencies. This arrangement forms; what we call electromagnetic spectrum.

We know that frequency $\nu = \frac{C}{\lambda}$. So if

we arrange the waves in the ascending order of wavelength, the frequency decreases as we go along the spectrum and vice versa. It may be noted that the boundary lines between different regions of the spectrum are not very sharp and well defined.

Different e.m. waves are listed below along with their wavelength range, method of production and characteristic properties.

Electromagnetic waves transfer energy in different forms (such as heat, light etc.) from one place to another. They all move with the velocity of light. However their frequencies and wavelengths are different and are regulated by the equation

$$\gamma \lambda = C$$

- where C = velocity of light
- γ = Frequency
- λ = wavelength

The range of their wavelength is very large. We can arrange them in the order of magnitude of their respective wavelengths and call it (the ordering) as electromagnetic spectrum. It may be noted that the boundary lines between different regions are not very sharp and well-defined, as the electromagnetic spectrum is continuous, but not discrete.

Complete electromagnetic spectrum :

Name of the rays	Wavelength range	Method of production	Properties
1. γ -rays	$10^{-8}m$ to $10^{-10}m$	Emittd in disintegration of nuclei of atoms	Phosphorescence, Fluorescence, polarisation, diffraction, neutral, highly penetrating, Affect photographic plate
2. X-rays	$10^{-10}m$ to $10^{-8}m$	produced by striking high speed electrons on heavy targets	Chemical reaction on photographic plates, fluorescence, phosphorescence, ionisation etc. but less penetrating than γ -rays.

3. Ultraviolet radiation	10^{-8} m to 10^{-7} m	Sun, hot vacuum spark arc, spark and ionised gases	All properties of γ -rays, but less penetrating, produce photo-electric effect.
4. Visible radiation	4×10^{-7} m to 7.8×10^{-7} m	Radiated from ionised gases and incandescent bodies	Reflection, refraction, interference, diffraction, polarisation, photo-electric effect, photographic action and sensation of sight
5. Infrared radiation	7.8×10^{-7} m to 10^{-3} m	From hot bodies	Heating effect on thermopiles and bolometer, reflection, refraction, diffraction, photographic action.
6. Hertzian and short radiowaves (contains microwaves)	10^{-3} m to 1m	Produced by spark discharge	They are reflected, refracted and diffracted, produce spark in the gaps of receiving circuits, waves of wavelength from 10^{-3} m to 3×10^{-3} m are also called "micro waves".
7. Long radio (or, wireless waves)	1m to 10^4 m	From spark gap discharges and oscillating electric circuits.	They are reflected, refracted and diffracted

In the above table, the radiation which directly concerns us is the visible spectrum (wavelength = 4×10^{-7} to 7.8×10^{-7} m) as they are somewhat responsible in creating the sensation of different colours, depending on their wavelength. This can be summarised as below :

Visible Spectrum :

Colour	Wavelength range in meter
Violet	4×10^{-7} --- 4.4×10^{-7}
Blue	4.4×10^{-7} --- 4.8×10^{-7}
Green	4.8×10^{-7} --- 5.6×10^{-7}
Yellow	5.6×10^{-7} --- 5.9×10^{-7}
Orange	5.9×10^{-7} --- 6.3×10^{-7}
Red	6.3×10^{-7} --- 7.8×10^{-7}

It is found that out of these different colours, the human eye is most sensitive to green-yellow light (5.6×10^{-7} m).

Ex. 14.1: Refractive index of water is 1.33. The velocity of light in vacuum is 3×10^5 km per second. Find the velocity of light in water.

Soln.

$${}_a\mu_w = \frac{\text{Velocity of light vacuum}}{\text{Velocity of light in water}}$$

$$\therefore 1.33 = \frac{3 \times 10^5}{\text{Velocity of light in water}}$$

$$\begin{aligned} \therefore \text{Velocity of light in water} &= \frac{3 \times 10^5}{1.33} \\ &= 2.26 \times 10^5 \text{ km / sec} \end{aligned}$$

Ex. 14.2 : In Young's Double slit experiment, the separation of four bright fringes is 2.5 mm when the wavelength used is 6.2×10^{-7} m . The distance from the slits to the screen is 0.80m. Calculate the separation of the two slits.

Soln.

$$\text{We use the relation : } w = \frac{\lambda D}{2d}$$

Given

$$w = \text{Fringe width} = \frac{2.5}{4} \times 10^{-1}$$

$$= 0.625 \times 10^{-1} \text{ cm}$$

$$\lambda = 6.2 \times 10^{-7} \text{ m} = 6.2 \times 10^{-5} \text{ cm}$$

$$D = \text{Distance between slits and the screen} \\ = 0.80 \text{ m} = 80 \text{ cm}$$

$$\therefore 2d = \text{Separation between the two slits} = \frac{\lambda D}{w}$$

$$= \frac{6.2 \times 10^{-5} \times 80}{.625 \times 10^{-1}} = 0.08 \text{ cm}$$

Ex. 14.3 : Two coherent sources 1mm apart produce interference fringes 0.2 mm apart on a screen 40 cm away. Calculate the wavelength of light used in Angstrom.

Soln.

$$\text{We use the relation } \lambda = \frac{w(2d)}{D}$$

Given

$$2d = \text{Separation between two coherent sources}$$

$$= 0.1 \text{ cm}$$

$$w = \text{fringe width}$$

$$= 0.02 \text{ cm}$$

$$D = \text{Distance between the sources and screen}$$

$$= 40 \text{ cm}$$

$$\therefore \lambda = \frac{0.02 \times 0.1}{40}$$

$$= \frac{2 \times 10^{-2} \times 10^{-1}}{4 \times 10^1}$$

$$= .5 \times 10^{-4}$$

$$= (5000 \times 10^{-4}) \times 10^{-4} \text{ cm}$$

$$= 5000 \times 10^{-8} \text{ cm}$$

$$= 5000 \text{ \AA}$$

Ex. 14.4 : In Young's double slit experiment, when using a source of light of wavelength 5000 \AA , the fringe-width observed is 0.60 cm. If the distance between the screen and the slit is reduced to half, what should be the wavelength of light source to get fringes 0.40 cm wide ?

Soln.

We use the relation :

$$\text{Wave length} = \text{fringe width} \left(\frac{2d}{D} \right) \dots(1)$$

$$\text{Given } \lambda = 5000 \text{ \AA} = 5000 \times 10^{-8} \text{ cm}$$

$$w = \text{fringe width} = 0.6 \text{ cm}$$

$$\therefore \frac{2d}{D} = \frac{\lambda}{w}$$

$$= \frac{5000 \times 10^{-8}}{.6} \dots(2)$$

$$\text{Now the distance between screen and slit} = \frac{D}{2}$$

$$\text{and the corresponding fringe width} = 0.4 \text{ cm}$$

Substituting these values in the fringe-width equn (1) :

$$\lambda = .4 \left(\frac{2d}{D/2} \right)$$

$$= .4 \times 2 \left(\frac{2d}{D} \right)$$

$$= .4 \times 2 \times \frac{5000 \times 10^{-8}}{.6} \quad (\text{by eq. 2})$$

$$= \frac{20000}{3} \times 10^{-8}$$

$$= 6666.7 \times 10^{-8} \text{ cm}$$

SUMMARY

1. **Wave front** : The surface joining points having the same phase of vibration in a wave motion is called a wave front.
The shape of a wave-front is determined from the shape of the light-source, from which the wave-front is derived.
2. **Ray** : A line joining the point source and any point on the wave-front shows the direction in which the energy propagates. This straight line is perpendicular to the wave-front and is called a ray.
3. **Huygen's wave theory** : Each point in a source of light sends out waves in all directions in a hypothetical medium, called ether.
As per Huygen's principle, each point on a wave-front acts as a center of new disturbance and emits its own set of spherical waves known as secondary wavelets. The secondary wavelets travel in all directions with the velocity of light. The locus (or envelope) of these wavelets vibrating in the same phase and in the forward direction gives the position of the new wavefront at a later time.
4. **Interference** : Superimposition of waves from coherent sources, having same or slightly different amplitude but differing by a constant phase difference produces interference.
5. **Conditions for interference of light** :
 - a) Coherent sources
 - b) Waves of same wavelength and time-period.
 - c) Small separation between two coherent sources
 - d) Large distance between coherent sources and screen
 - e) Equal amplitude interfering waves
 - f) Narrow sources
6. **Methods of producing coherent sources** :
 - a) Division of wave front : Ex. : Young's Double slit experiment, Fresnel's Biprism, Lloyd's mirror
 - b) Division of amplitude : Newton's rings, Michelson's interferometer.
7. **Young's double slit experiment** :

$$I = R^2 = a_1^2 + a_2^2 + 2a_1a_2 \cos \delta$$

$$I = \text{Resultant intensity as a result of interference}$$

$$a_1, a_2 = \text{Amplitude of the two interfering waves}$$

$$\delta = \text{phase difference between the two waves.}$$
8. **Path difference and phase difference** :

$$\text{Phase difference} = \frac{2\pi}{\lambda} (\text{Path difference})$$
9. **Condition for maximum intensity** :

$$I_{\max} = (a_1 + a_2)^2$$
 if phase difference = $\delta = 2n\pi$
 or, Path difference = $0, \lambda, 2\lambda, \dots, n\lambda$
 where $n = 0, 1, 2, \dots$
10. **Condition for minimum intensity** :

$$I_{\min} = (a_1 - a_2)^2$$
 if phase difference = $\delta = (2n + 1)\pi$
 or, Path difference = $\frac{\lambda}{2}, \frac{3\lambda}{2}, \dots, (2n + 1)\frac{\lambda}{2}$
 where $n = 0, 1, 2, \dots$
11. **Fring width** = $w = \frac{\lambda D}{2d}$
 where D = distance between sources and screen
 $2d$ = separation between two coherent sources
 λ = wavelength of light.

MODEL QUESTIONS

A. Multiple Choice Type Questions :

1. Two slits separated by a distance of 1 mm are illuminated with red light of wavelength 6.5×10^{-7} m. The interference fringes are observed on a screen placed 1 m from the slits. The distance between the third dark fringe and the fifth bright fringe is equal to
 - a) 0.65 mm
 - b) 1.63 mm
 - c) 3.25 mm
 - d) 4.88 mm
2. A monochromatic visible light consists of
 - a) a single ray of light
 - b) light of a single wavelength
 - c) light of a single wavelength with all the colours of the spectrum of white light.
 - d) light consisting of many wavelengths with a single colour.
3. Speed of light in vacuum is
 - a) 2.9×10^{-1} m/sec
 - b) 3×10^8 m/sec
 - c) 3.1×10^{-8} m/sec
 - d) 3×10^6 m/sec
4. Light energy has
 - a) particle like properties
 - b) wave like properties
 - c) sometimes wave like properties and sometimes particle like properties.
 - d) neither wave nor particle nature
5. In a certain double slit experimental arrangement, interference fringes of width 1.0 mm each are observed when light of wavelength 5000 \AA is used. Keeping the set-up unaltered, if the source is replaced by another of wavelength 6000 \AA , the fringe width will be
 - a) 0.5 mm
 - b) 1.0 mm
 - c) 1.2 mm
 - d) 1.5 mm
6. When light travels from an optically rarer medium to an optically denser medium, the velocity decreases because of change in
 - a) wavelength
 - b) frequency
 - c) amplitude
 - d) phase
7. Monochromatic light ($\lambda = 500 \text{ nm}$) illuminates a pair of slits 1 mm apart. On a screen 2 m away, the fringe width is
 - a) 0.25 mm
 - b) 0.1 mm
 - c) 1.0 mm
 - d) 10 mm
8. When light wave suffers reflection at the interface from air to glass, the change in phase of the reflected wave is equal to
 - a) 0
 - b) $\pi/2$
 - c) π
 - d) 2π
9. Four different independent waves are represented by
 - i) $y_1 = a_1 \sin \omega t$
 - ii) $y_2 = a_2 \sin 2\omega t$
 - iii) $y_3 = a_3 \cos \omega t$
 - iv) $y_4 = a_4 \sin(\omega t + \pi/3)$

With which of the two waves interference is possible

 - a) In (i) and (iii)
 - b) In (i) and (iv)
 - c) In (iii) and (iv)
 - d) not possible with any combination

10. If the speed of light in vacuum is c m/sec, then velocity of light in a medium of refractive index 1.5 is
- $1.5c$
 - c
 - $c/1.5$
 - can have any velocity
11. The fringe width in a Young's double slit experiment can be increased if we decrease
- separation of the slits
 - width of the slits
 - distance between slit and screen
 - wavelength of the source of light
12. In the interference pattern, energy is
- created at the positions of maxima
 - destroyed at the positions of minima.
 - conserved but is redistributed
 - none of the above
13. Which of the following does not support the wave nature of light
- Interference
 - Diffraction
 - Polarisation
 - Photoelectric effect
14. In Young's double slit experiment the separation between the slits is halved and the distance between the slits and the screen is doubled. The fringe width is
- unchanged
 - halved
 - doubled
 - quadrupled
15. Young's experiment establishes that
- Light consists of waves
 - Light consists of particles
 - Light is neither particle nor wave
 - Light is both particle and wave
16. The wave theory of light in its original form was first postulated by
- Issac Newton
 - Christian Huygens
 - Thomas Young
 - Albert Einstein
17. In Young's double slit arrangement, the central fringe is
- always dark
 - always bright
 - may be dark or bright depending on the distance between source and screen.
 - neither dark nor bright
18. If the intensity of the two interfering beams in Young's double slit experiment be I_1 and I_2 then the contrast between the maximum and minimum intensity is good when
- I_1 is much greater than I_2
 - I_1 is much smaller than I_2
 - $I_1 = I_2$
 - Either $I_1 = 0$, or $I_2 = 0$
19. In Young's interference experiment with one source and two slits, one slit is covered with a cellophane sheet so that half the intensity is absorbed. Then
- no fringe is obtained
 - bright fringes will be brighter and dark fringes will be darker.
 - all fringes will be darker
 - bright fringes will be less bright and dark fringes will be less dark.
20. If Young's interference experiment is performed using two separate identical sources of light instead of using two slits and one bulb

- a) the interference fringes will be brighter
 b) the interference fringes will be coloured.
 c) the interference fringes will be darker
 d) no fringes will be obtained
21. Pick up the longest wavelength from the following types of radiations
 a) blue light b) gamma rays
 c) X-rays d) red light
22. For constructive interference to take place between two monochromatic light waves of wavelength λ , the path difference should be
 a) $(2n-1)\frac{\lambda}{4}$ b) $(2n-1)\frac{\lambda}{2}$
 c) $n\lambda$ d) $(2n+1)\frac{\lambda}{2}$
23. The intensity ratio I_1/I_2 of two interfering sources in Young's experiment is 4. The ratio I_{\max}/I_{\min} is
 a) 4 : 1 b) 2 : 1
 c) 3 : 1 d) 9 : 1
24. Newton postulated his corpuscular theory on the basis of
 a) Newton's rings
 b) rectilinear propagation of light
 c) colours of thin films
 d) dispersion of white light into colours
25. Two sources of waves are called coherent, if
 a) both have the same amplitude of vibration
 b) both produce waves of the same wave length.
 c) both produce waves of the same wavelength having constant phase difference.
 d) both produce waves having the same velocity.
26. A wave front is an imaginary surface where
 a) phase is always same for all the points
 b) phase changes at constant rate in all directions.
 c) constant phase difference is maintained
 d) phase changes at a rate which changes per unit length.
27. Which of the following phenomenon is not common to sound and light waves
 a) Interference b) Diffraction
 c) Polarisation d) Reflection
28. If the speed of red light is denoted by V_r and the speed of violet light by V_v , then for vacuum
 a) $V_r > V_v$
 b) $V_r = V_v$
 c) $V_r < V_v$
 d) none of the above
29. Huygen's conception of secondary waves
 a) allows us to find the focal length of a thick lens.
 b) is a geometrical method to find a wave front.
 c) is used to determine the velocity of light.
 d) is used to explain polarisation
30. The idea of the quantum nature of light has emerged in an attempt to explain
 a) Interference
 b) Diffraction
 c) Radiation spectrum of a black body
 d) Polarisation

B. Answer as directed :

- Two waves having same wavelength and amplitude but having constant phase difference with time are known as ____ waves.
- A plane wave front is produced if the source is at ____.
- According to Huygen, the medium pervading the entire universe is ____.
- In a Young's double slit experiment performed with a source of white light, only black and white fringes are observed. (True/False)
- In an interference pattern, using two identical slits, the intensity of a central maximum is I_0 . One of the two slits is now covered with black paper. What is the intensity at the same point now ?
- Two coherent monochromatic light beams of intensities I and $4I$ are superposed. What are the maximum and minimum possible intensities in the resulting beam ?
- In Young's double slit experiment, we get 60 fringes in the field of view of monochromatic light of wavelength 4000 \AA . If we use monochromatic light of wavelength 6000 \AA , then what is the number of fringes obtained in the same field of view ?
- What is the frequency of light having a wavelength 3000 \AA ?

C. Very Short Answer Type Questions :

- Does the velocity of light change from medium to medium ? If no, give the necessary equation.
- In Young's double slit experiment, what will be the central fringe, if white light is used ?
- Does the fringe width for dark fringe differ from that for bright fringe ?

- If C is the velocity of light in vacuum, find the velocity of light in glass of refractive index 1.5.
- Is the bright fringe in interference-pattern obtained by violating the Principle of conservation of energy ?
- How would the angular separation of interference fringes in Young's double slit experiment change when the distance of separation between the slits and the screen is doubled ? [CBSE Sample Paper]
- Why is the interference pattern not detected, when two coherent sources are far apart ? [CBSE 1998]
- No interference pattern is detected when two coherent sources are infinitely close to each other. Why ? [CBSE 1998]

D. Short Answer Type Questions :

- What are the reasons to believe that light is a wave motion ?
- Explain and illustrate what you mean by plane wavefront.
- How is the refractive index of a medium related to the velocity of light according to Huygen's Principle ? What is the importance of this relation ?
- When light waves from two coherent sources interfere, they produce darkness at some points. What becomes of the energy ?
- Two tuning forks can produce interference; but two independent sources of light (like two candles) cannot produce interference - Explain.
- If a broad sources of light is used in place of the very narrow slit in the Young's experiment, how will the interference pattern be affected ? Explain.
- What type of interference pattern will be observed, if a white light source in place of monochromatic source of light is used in Young's experiment ?

8. When we try to clean spectacle lenses with water, the glass becomes more non-reflecting as the water evaporates. Explain.

[Hints: Interference reduces reflection]

9. What will happen to interference pattern if Young's apparatus is placed under water?

[Hint: Fringe width decreases]

10. State the reason, why two independent sources of light cannot be considered as coherent sources. [CBSE 2008]

E. Long Answer Type Questions :

1. Explain clearly Huygen's Principle of the propagation of light wave.
2. Describe the basic conditions for observing interference fringes on the screen.
3. What do you mean by interference of light? Explain the formation of 'maxima and minima' by applying the Principle of superposition.
4. What is interference? Describe Young's experiment for demonstrating the phenomena of interference of light and explain it by wave theory. Derive the formula used.
5. Explain with necessary theory how you can determine the wavelength of sodium light using Young's double slit experiment.

F. Numerical Problems :

1. How long will light take in travelling a distance of 300 metres in glass. $\mu_{\text{glass}} = 1.5$ and velocity of light in vacuum = 3×10^8 m/sec.
2. Light takes 8 minutes 20 seconds to reach the earth from the sun. If the space

between the sun and earth be filled with water, what time will light take to reach the earth. Given $\mu_{\text{water}} = 1.33$.

3. Two slits are separated by a distance of 0.03 cm. An interference pattern is produced at a screen 1.5 m away. The fourth bright fringe is at a distance of 1cm from the central maximum. Determine the wavelength of light used.
4. Two straight narrow slits 0.30 mm apart are illuminated by a monochromatic source of wavelength 5.9×10^{-7} m. Fringes are obtained at a distance of 0.30m from the slit. Find the width of the fringes.
5. White light is used to produce Young's fringes with double slits having a slit aperture of 0.04cm. The distance between the slit and the screen on which fringes are formed is 140 cm and the distance between successive dark places in the fringe pattern is 1.7 mm. Find the average wavelength of white light.
6. The distance between two slits in Young's interference experiment is 0.03 cm. The fourth bright fringe is obtained at a distance of 1 cm from the central fringe on a screen placed at a distance of 1.5 m from slits. Calculate the wavelength of light used. [CBSE 2005, 1995]
7. In Young's experiment, the width of fringes obtained with light of wavelength 6000 \AA is 2.0 mm. What will be the fringe width if the entire apparatus is immersed in a liquid of refractive index 1.33? [CBSE 1991]
8. In Young's double slit experiment, using light of wavelength 400 nm, interference fringes of width 'X' are obtained. The wavelength of light is increased to 600 nm and the separation between the slits is halved. If one wants the observed fringe

- width on the screen to be same in the two cases, find the ratio of the distance between the screen and the plane of interfering sources with the two arrangements. [CBSE 2004]
9. Find the ratio of intensities at two points on a screen in Young's double slit experiment when waves from the two slits have a path difference of (i) 0 (ii) $\lambda/4$.
[CBSE AI 2000, 2003]
 2. In young's double slit experiment the fringe width depends on the order of fringe.
 3. In Young's double slit experiment the fringe width decreases if the distance between the source and screen increases.
 4. Speed of light in vacuum is 3×10^8 cm.
 5. Fringe width for dark fringe differs from fringe width for bright fringe, in Young's double slit experiment.

G. Correct the following sentences :

1. Wave theory of light explains photoelectric effect but not interference.

ANSWERS

A. Multiple Choice Type Questions :

1. (b) 2. (b) 3. (b) 4. (c) 5. (c) 6. (a) 7. (c) 8. (c)
 9. (d) 10. (c) 11. (a) 12. (c) 13. (d) 14. (d) 15. (a) 16. (b)
 17. (b) 18. (c) 19. (d) 20. (d) 21. (d) 22. (c) 23. (d) 24. (b)
 25. (c) 26. (a) 27. (c) 28. (b) 29. (b) 30. (c)

B. 1. Coherent 2. Infinity 3. Ether 4. False 5. $I_0/4$ 6. 9I and I 7. 40 8. 10^{15} CPS

C. Very Short Answer Type Questions :

1. ${}_a\mu_g = \frac{v_a}{v_g}$

2. White fringe; as the path difference is zero.

3. No

4. $\frac{2}{3}C$

5. No

F. Numerical Problems :

1. 150×10^{-8} Sec, or 1500 ns

2. 666.7 Sec

3. 5000 A⁰

4. 0.59 mm

5. 4857 A⁰

6. 5×10^{-7} m,

7. 1.5 mm,

8. $D_2/D_1 = 1/3$,

9. $l_1/l_2 = 2/1$.

15

Relativity

Once in emperor Akbar's Durbar, an interesting event happened. Akbar drew a line and asked to the members present, whether they would make the line shorter without rubbing it off.

None could find out a way except, of course, the wise Birbal. Birbal drew a bigger line, near to the line previously drawn by Akbar and declared that Akbar's line has now become shorter.

In fact, Birbal is completely correct, as Akbar's line has appeared shorter, relative to that of Birbal's. This incident illustrates the 'relative' principle in space. Several facts (like the time in India is not identical with the time in USA or Canada etc.) can prove that time is also relative.

Indeed there is nothing like absolute space or absolute time. They are relative and regulated by Relativity Principle.

According to Newton, time and mass are independent of each other and their measurements do not change, even if the observers are taking measurements, while in rest-position or in movement. But strictly speaking, these considerations are not correct and they have been suitably modified by Einstein's special theory of Relativity.

15.1: Some important terms and definitions:

It is desired to learn about some important terms and definitions before taking up the theory of relativity:

Event :

Any occurrence taking place in space at a particular time is an event. Examples of event are : Sun-rise, Dropping of a bomb. Example of a "series of events" are ticking-sound of a clock.

Observer :

An observer may be a person or an equipment. The work of any observer is that it sees or observes an event and takes its measurements. From these observations and measurements, inferences can be drawn.

Frame of reference :

The description of a natural phenomenon or event requires a proper frame of reference. The measurements of space and time will not be correct and complete unless the frame of reference is mentioned, with reference to which the observations have been taken. An observer must be stationed in the frame of reference so that he will have a feeling that he is at rest.

Thus an event to be fully described, requires not only an observer but a suitable frame of reference also.

Inertial frame of reference :

It is that frame of reference, in which Newton's first law (i.e, the law of inertia) holds good. In this frame a body moves uniformly and in rectilinear motion. An observer in such a

system is called an inertial observer. If a frame of reference moves with constant velocity relative to an inertial frame, then this also becomes an inertial frame.

15.2: Classical Principle of relativity : Galilean-Newtonian Transformation Equation:

Any event can be described by the space-time co-ordinates of a particular inertial frame. It can also be described in another inertial frame by using the Galilean transformation equations.

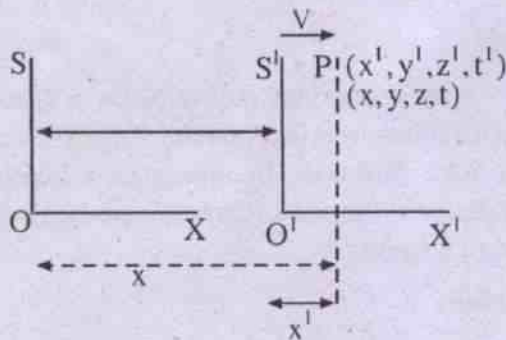

Fig. 15.1

(Galilean transformation)

Let $S =$ An inertial frame

$S' =$ Another inertial frame moving with a velocity v along the x -axis. (we assume that there is no velocity-component along y or z axis).

At $t = 0$

O and O' had coincided when an event at P takes place.

After time t , O has moved to O' , so that $OO' = Vt$

After time t , let the event P be described by (x, y, z, t) in inertial frame S and by (x', y', z', t') in the inertial frame S' , which has moved a distance Vt ($\because OO' = vt$) during this time interval.

Then we can write the transformation eqns. as :

$$\begin{aligned}x' &= x - vt \\y' &= y \\z' &= z \\t' &= t\end{aligned}\quad \dots 15.2.1$$

These equations are called the Galilean transformation equations. We have written $t = t'$, by assuming that time flows at the same rate in all inertial frames. This assumption is valid, when we consider the velocity v as very small.

Eq. (15.2.1) have been written when S' is moving with a velocity v w.r.t. S along the +ve x -direction. However, if S' is stationary and S is moving with a velocity v w.r.t. S' along the -ve x -direction, eq. (15.2.1) can be written by putting $(-v)$ in place of v , as follows :

$$\begin{aligned}x &= x' + vt' \\y &= y' \\z &= z' \\t &= t'\end{aligned}\quad \dots 15.2.2$$

Eq. (15.2.2) are known as the inverse transformation equations.

15.3: Consequences of Galilean relativity :

Transformation of length :

Let a rod be placed in the frame S , parallel to the x -axis. Its length (ℓ) can be measured by the difference between the x -co-ordinates of its two ends.

$$\text{Hence } \ell = x_2 - x_1 \quad \dots 15.3.1$$

In frame S' , $x'_1 = x_1 - vt$

$$\text{and } x'_2 = x_2 - vt$$

$$\therefore \ell' = x'_1 - x'_2$$

$$= (x_1 - vt) - (x_2 - vt)$$

$$= x_1 - x_2$$

$$= \ell \text{ by eqn. 15.3.1}$$

Thus the length is invariant i.e., does n't change in Galilean transformation.

Transformation of velocity :

From eq. 15.2.1, we have

$$x' = x - vt$$

∴ Differentiating this w.r.t. time :

$$\frac{dx'}{dt'} = \frac{dx}{dt} - v$$

or, $u'_x = u_x - v$...15.3.2

where u'_x = x-component of velocity u' in frame S' .

u_x = x-component of velocity u in frame S .

Eq. 15.3.2 is known as the classical law of velocity transformation. The velocity is not invariant (because $u'_x \neq u_x$) and depends on different inertial frames and their corresponding relative velocities.

Transformation of acceleration :

Differentiating eq. 15.3.2 w.r.t. time, we get

$$\frac{du'_x}{dt'} = \frac{du_x}{dt}$$

∴ $a'_x = a_x$...15.3.3

where a'_x = x- component of acceleration a' in frame S'

a_x = x-component of acceleration a in frame S

Eq. 15.3.3 shows that acceleration is invariant and hence an absolute quantity in Galilean transformation, even though it is not so in the case of velocity of a particle.

Transformation of the fundamental law of dynamics (Newton's law) :

According to Newton's law,

$$\text{force} = \text{mass} \times \text{acceleration}$$

But mass is regarded as an absolute quantity and is independent of the inertial frames.

Hence force, being the product of mass and acceleration, is invariant, in inertial frames, since both the quantities (mass and acceleration) are invariant. Thus Newton's laws are the same in inertial frames. This means that all inertial frames are absolutely equivalent and none of them can be preferred to others. This is called the classical (or, Galilean) Principle of relativity.

In nature, we have several types of forces like, position-dependent forces (Gravitational; electrostatic, elastic forces etc.) Since forces in general are invariant in Galilean transformations, all these forces can be considered as invariant. Therefore the fundamental law of mechanics is also invariant under Galilean transformation.

However, problems arise, when we apply Galilean transformation to the Maxwell's equations in electrodynamics; because they no more remain invariant; but change their shape or form in different inertial frames. This has led to rethinking about the application of Galilean transformations to all cases and their limitations.

15.4: Michelson-Morley experiment (1881):

We know that the earth is moving. We are interested to find out its absolute velocity. For this, we need something which is at rest, so that the absolute velocity can be measured with respect to this. Ether fulfils this requirement, as it is an all-prevading medium, which is at rest.

On this basis, an experiment was performed by Michelson and Morley to detect the motion of the earth.

The experimental set up has been shown in the fig no. 15.2 which is basically an interferometer, with its two arms (say M_1P and M_2P) being \perp_r to each other.

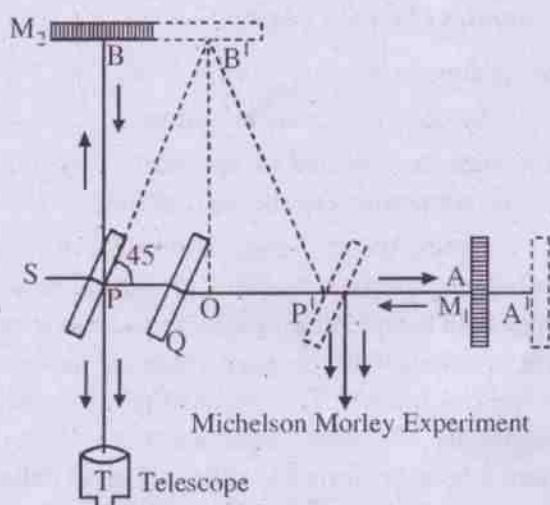

Fig. 15.2

M_1, M_2 = Two plane mirrors, of excellent optical quality, being silvered properly to avoid multiple, internal reflections

P, Q = Two plane glass plates, of equal thickness and same material, out of which P is semi-silvered and Q is called compensating plate.

S = Monochromatic extended source

T = Telescope

The glass-plates P and Q are mounted vertically, but having an inclination of 45° to the interferometer-arms.

Consider a beam of light starting from S . On reaching P , it is partly reflected and partly transmitted. The reflected part is deviated by 90° and reaches M_2 , from where it is reflected back. Similarly, the transmitted part moves along PA and is reflected back by M_1 .

These two rays, thus returned to P , superimpose on each other and undergo interference, the fringe-pattern of which can be observed by the telescope T .

In this experimental set-up, we have introduced a glass-plate Q , because whereas the reflected part crosses twice the glass-plate P

(once while moving towards M_2 and then again on return from M_2) before finally reaching P , the transmitted ray will not cross any such glass-plate during its journey from P to A and back to P . Thus the reflected part travels more optical path than the transmitted counter part. Hence to equalise the optical path of both the reflected and transmitted parts, a glass, called Compensating plate, Q is introduced in the path of the transmitted part.

Had the earth been at rest, the optical path of the reflected and transmitted rays will be the same, as per the above arrangement. But as the earth is moving, the apparatus is also moving with it. Hence the positions of the reflections at M_1 and M_2 will correspondingly change, as shown by the dotted lines in the figure, from B to B' (for reflected part) and A to A' (for transmitted part). Thus the time taken by these rays to reach P will no more be same.

We will now calculate the time difference.

Let C = velocity of light

v = velocity of earth (apparatus)

$$PA = PB = \ell$$

Total path travelled by reflected ray

$$= PB'P'$$

$$= PB' + B'P'$$

$$= 2PB' \quad (\because PB' = B'P')$$

Further in right angled Δ $P'BO$,

$$PB'^2 = PO^2 + OB'^2 \quad \dots 15.4.1$$

Let us say that by the time (say, t) B moves to B' , the light-ray travels from P to B' .

$$\text{Thus } BB' = vt$$

$$PB' = ct$$

so that eq. 15.4.1 gives

$$(ct)^2 = (vt)^2 + \ell^2 \quad (\because PO = PB)$$

or, $t^2(c^2 - v^2) = \ell^2$

$$t = \frac{\ell}{(c^2 - v^2)^{\frac{1}{2}}}$$

Let $t_1 =$ Time taken to travel from P to B' & B' to P'.

Then $t_1 = 2t$

$\therefore t_1 = 2t$

$$= \frac{2\ell}{(c^2 - v^2)^{\frac{1}{2}}}$$

$$= \frac{2\ell}{c} \left\{ 1 - \frac{v^2}{c^2} \right\}^{-\frac{1}{2}}$$

$$= \frac{2\ell}{c} \left(1 + \frac{v^2}{2c^2} \right)$$

by applying Binomial theorem and considering that $v \ll c$

...15.4.2

For the transmitted ray, the time taken for the onward journey (PA)

$$= \frac{PA}{c - v}$$

where $c - v =$ Relative velocity of the apparatus (Earth) w.r.t. velocity of light (c & v , being in the same direction)

$$= \frac{\ell}{c - v}$$

and the time taken for the backward journey (A'P')

$$= \frac{A'P'}{c + v}$$

where $c + v =$ Relative velocity of the apparatus (c & v , being in opposite directions)

$$= \frac{\ell}{c + v} \quad (\text{since } A'P' = AP = \ell)$$

Thus the total time of travel for the transmitted ray = t_2 (say)

$$= \frac{\ell}{c - v} + \frac{\ell}{c + v}$$

$$= \frac{2\ell c}{c^2 - v^2}$$

$$= \frac{2\ell c}{c^2} \left[1 - \frac{v^2}{c^2} \right]^{-1}$$

$$= \frac{2\ell}{c} \left(1 + \frac{v^2}{c^2} \right) \quad \dots 15.4.3$$

\therefore The time difference = Δt (say)

$$= t_2 - t_1$$

$$= \frac{2\ell}{c} \left(1 + \frac{v^2}{c^2} \right) - \frac{2\ell}{c} \left(1 + \frac{v^2}{2c^2} \right)$$

$$= \frac{2\ell}{c} \cdot \frac{v^2}{2c^2}$$

$$= \frac{\ell v^2}{c^3}$$

Now path difference

$$= (\text{velocity of light}) (\text{Time difference})$$

$$= c (\Delta t)$$

$$= \frac{\ell v^2}{c^2}$$

Since for the shift of one fringe, path difference required is λ , we obtain :-

$$\begin{aligned} \text{Shift in the number of fringes} &= \frac{\text{Path difference}}{\text{Wave length}} \\ &= \frac{\ell v^2}{c^2 \lambda} \quad \dots 15.4.4 \end{aligned}$$

In case we rotate the apparatus by 90° , then an equal number of fringe-shift (as in eq. 15.4.4) will be added, so that we obtain :

The total shift (in terms of the number of fringes)

$$= \frac{2\ell v^2}{c^2 \lambda} \quad \dots 15.4.5$$

This can be numerically calculated as follows; by using the experimental data of Michelson and Morley :

$$\begin{aligned} \text{Given} \quad \ell &= 11 \text{ met} \\ v &= 3 \times 10^4 \text{ met / sec} \\ c &= 3 \times 10^8 \text{ met / sec} \\ \lambda &= 5.9 \times 10^{-7} \text{ met} \end{aligned}$$

$$\begin{aligned} \text{Then the total shift (in terms of the number} \\ \text{of fringes)} &= \frac{2 \times 11 \times (3 \times 10^4)^2}{(3 \times 10^8)^2 \times 5.9 \times 10^{-7}} \\ &= 0.37 \end{aligned}$$

As per the above data, we should obtain a fringe-shift 0.37. But even though the experiment was conducted by several scientists at different times of the year (so that variations in the earth's orbital velocity v may give some positive result), no fringe-shift was observed. In this context, it may be mentioned that the above equipment is accurate and it is capable of detecting a fringe-shift, as small as, of the order of 0.01. Hence it can be concluded that the null or negative result cannot be dismissed as inaccurate and suffers from experimental error.

We are forced to conclude that the velocity of earth relative to ether cannot be

determined. This has a highly significant consequence, i.e., the space or the medium, in which light propagates, does not move relative to earth. Hence there is no necessity to believe in the existence of a stationary medium carrying light (or, for that matter, absolute space). Thus it can be said that ether does not exist and the motion through ether is a meaningless concept.

15.5: Einstein's special theory of Relativity (1905) :

Albert Einstein (1879-1955) published a paper "On the electrodynamics of moving bodies", which laid the foundation of the special theory of relativity. It has two postulates.

(i) *Principle of relativity :*

The fundamental laws of physics and the equations describing them are invariant. This means that they have the same form for all inertial systems (i.e. for reference systems at rest, or moving with constant linear velocity relative to one another).

(ii) *The universal speed of light :*

The velocity of light in vacuum is independent of the relative motion of the source and the observer. Thus the velocity of light holds a unique position. It is an invariant, whereas all other speeds change on transition from one reference frame to another. This clearly contradicts Galilean law of addition of velocities, thus questioning the Galilean transformation equations.

Further these postulates present a new physical theory of space and time. Since we can not distinguish one inertial frame from another, whatever the experiment we perform, we have to reject the idea of absolute space and absolute motion. This has been confirmed by Michelson Morley experiment.

Keeping in view the above postulates of Einstein, we have to frame transformation equations, which satisfy :

1. The speed of light C must have the same value in all inertial frames.

2. The transformations must be linear. They should approach the Galilean transformations for low speeds (i.e., $v \ll C$).

3. Space and time are not absolute. They are inseparable and depend on the state of motion.

15.6: Lorentz transformation equations :

These are a set of equations, which satisfy Einstein's postulates of special theory of relativity. They connect the space-time coordinates of an event measured in two inertial frames which are in relative motion.

Ref. Fig.15.1: Let us start with $t = 0$ and $t' = 0$, when the two inertial frames of reference S and S' coincide in all respects, so that their origins O and O' also become one and the same.

Let a spherical wave front start from the coincident origins. When this wave reaches P , its coordinates are $P(x,y,z,t)$ in inertial frame S and (x', y', z', t') in the inertial frame S' which is moving with a uniform velocity v along the x -axis w.r.t. the frame S and there is no component of velocity along the y or z -axis.

Hence we can write :

$$x^2 + y^2 + z^2 = c^2 t^2 \quad \dots 15.6.1$$

$$\text{and } x'^2 + y'^2 + z'^2 = c^2 t'^2 \quad \dots 15.6.2$$

Deducting (15.6.2) from (15.6.1) and substituting $y' = y$ and $z' = z$, we obtain :

$$x^2 - c^2 t^2 = x'^2 - c^2 t'^2 \quad \dots 15.6.3$$

In Galilean transformation, eqn. (15.2.1), we had obtained a linear relation :

$$x' = x - vt$$

In this case, let us try a very simple mathematical treatment. Let us write the linear equation in the following way :

$$x' = k(x - vt)$$

$$\text{and } t' = k(t - bx) \quad \dots 15.6.4$$

Where k and b are unknown quantities but are independent of x . In eqn. (15.6.4) we have taken due care to maintain the linearity of space and time co-ordinates. Substituting these values in the R.H.S. of eqn. (15.6.3), we have :

$$\begin{aligned} x^2 - c^2 t^2 &= [k(x - vt)]^2 - c^2 [k(t - bx)]^2 \\ &= k^2(x^2 + v^2 t^2 - 2vtx) \\ &\quad - c^2 [k^2(t^2 + b^2 x^2 - 2tbx)] \\ &= (k^2 - c^2 k^2 b^2)x^2 + \\ &\quad (2vtk^2 + 2c^2 k^2 tb)x \\ &\quad + (k^2 v^2 - c^2 k^2)t^2 \end{aligned}$$

Equating the co-efficient of x^2, t^2 in the L.H.S. and R.H.S. separately, we get :

$$1 = k^2 - c^2 k^2 b^2 \quad \dots 15.6.5$$

$$\text{and } -c^2 = k^2 v^2 - c^2 k^2 \quad \dots 15.6.6$$

Eqn. (15.6.6) gives : $-c^2 = -k^2(c^2 - v^2)$

$$\therefore k^2 = \frac{c^2}{c^2 - v^2}$$

$$\text{or } k = \frac{1}{\sqrt{1 - v^2/c^2}} \quad \dots 15.6.7$$

Substituting (15.6.7) in (15.6.5), we obtain :

$$\begin{aligned} 1 &= k^2(1 - c^2 b^2) \\ &= \frac{c^2}{c^2 - v^2}(1 - c^2 b^2) \end{aligned}$$

$$\text{so that } b^2 = \frac{v^2}{c^4}$$

$$\text{or } b = \frac{v}{c^2} \quad \dots 15.6.8$$

Substituting (5.6.7) and (5.6.8) in (5.6.4), we have :

$$x' = \frac{x - vt}{\sqrt{1 - \frac{v^2}{c^2}}}$$

and

$$t' = \frac{t - \frac{vx}{c^2}}{\sqrt{1 - \frac{v^2}{c^2}}} \quad \dots 15.6.9$$

For the y and z axis, we have : $y' = y, z' = z$.

The inverse Lorentz transformations can be obtained by mutual interchange of primed and unprimed coordinates and replacing v by $-v$ (as has been done in eqn. (15.2.2))

$$x = \frac{x' + vt'}{\sqrt{1 - \frac{v^2}{c^2}}}$$

$$y = y'$$

$$z = z'$$

$$t = \frac{t' + \frac{vx'}{c^2}}{\sqrt{1 - \frac{v^2}{c^2}}} \quad \dots 15.6.10$$

The Lorentz transformation equations have the following important characteristics :

- (1) When the velocity (v) is small, $v/c \rightarrow 0$. Hence the eqn. (15.6.9) reduce to eqn. (15.2.1). Thus Lorentz equations reduce to Galilean equations in the limit of low-velocity. This shows that Lorentz equations represent the general case and Galilean equations are special cases of Lorentz equations.
- (2) The equation involving time-transformation of Lorentz contains the spatial coordinate. This suggests that

space and time are inter-related. Thus the unified space-time considerations should be taken up, in various situations.

- (3) If we substitute $v > c$ in Lorentz equations above, x' and t' will become impossible. Hence the speed of a body with velocity greater than that of light is not acceptable.

15.7: Simultaneity :

Suppose two events occur at the same time in one inertial frame. Then they may not occur at the same time to another inertial frame. Thus the concept of simultaneity (i.e., events occurring at the same time, or, simultaneously) is not absolute.

Let, in a frame S, event 1 occur at x_1, y_1, z_1 at time t_1

and event 2 occur at x_2, y_2, z_2 at time t_2

Now consider another frame S', moving with a uniform vel u , w.r.t. frame S along the $x - x'$ direction.

Then, by Lorentz transformation equations, we can write :

$$x_1' = \frac{x_1 - vt_1}{\sqrt{1 - v^2/c^2}}$$

$$x_2' = \frac{x_2 - vt_2}{\sqrt{1 - v^2/c^2}}$$

$$t_1' = \frac{t_1 - \frac{vx_1}{c^2}}{\sqrt{1 - v^2/c^2}}$$

and

$$t_2' = \frac{t_2 - \frac{vx_2}{c^2}}{\sqrt{1 - v^2/c^2}}$$

From the above, we can write :

$$x_2' - x_1' = \frac{[(x_2 - x_1) - v(t_2 - t_1)]}{\sqrt{1 - v^2/c^2}}$$

...15.7.1

$$\text{and } t_2^1 - t_1^1 = \frac{\left[(t_2 - t_1) - \frac{v}{c^2}(x_2 - x_1) \right]}{\sqrt{1 - v^2/c^2}} \quad \dots 15.7.2$$

$(t_2^1 - t_1^1)$ in eqn. (15.7.2) gives the time-interval as measured in the frame S' between the two events 1 and 2 for which the time-interval is $(t_2 - t_1)$ in S .

If we consider that the two events were simultaneous in S , then $t_2 = t_1$. Substituting this in eq. (15.7.2) we have :

$$t_2^1 - t_1^1 = \frac{-\frac{v}{c^2}(x_2 - x_1)}{\sqrt{1 - v^2/c^2}} \quad \dots 15.7.3$$

$$\therefore t_2^1 - t_1^1 \neq 0$$

Thus even if the two events are simultaneous in S , they are not so in S' . (of course, they will be simultaneous if the two events occur at the same place in S , i.e. $x_2 = x_1$). Hence this leads to the conclusion that simultaneity is a relative concept.

In classical physics, the upper limit of velocity of light can be as large as ∞ . This, when substituted in eq. (15.7.2), gives

$$t_2^1 - t_1^1 = t_2 - t_1$$

Thus, in this situation, simultaneity becomes an absolute concept.

15.8: Lorentz (Fitzgerald) contraction :

The measured length of an object is decreased, if the object and the observer are in relative motion with respect to each other. That a moving body appears to be contracted in the direction of its motion is known as Lorentz contraction and is a consequence of the non-simultaneity.

Let us consider the frames S and S' .

Let the rod, having end coordinates as x_1^1 and x_2^1 , be kept in the frame S' and is moving along with S' with a velocity v along $x - x'$ axis, with respect to the frame S .

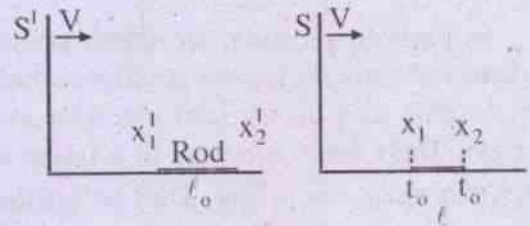

Fig. 15.3

Lorentz contraction

The length of the rod in frame $S' =$

$$x_2^1 - x_1^1 = l_0 \text{ (say)}$$

l_0 is also called the proper length.

By Lorentz transformation, we have :

$$x_1' = \frac{x_1 - vt_0}{\sqrt{1 - v^2/c^2}}$$

and

$$x_2' = \frac{x_2 - vt_0}{\sqrt{1 - v^2/c^2}}$$

$$\therefore x_2' - x_1' = \frac{(x_2 - x_1)}{\sqrt{1 - v^2/c^2}}$$

$$\text{or, } l_0 = \frac{l}{\sqrt{1 - v^2/c^2}}$$

$$\text{or, } l = l_0 \sqrt{1 - v^2/c^2}$$

$$\approx l_0 \left(1 - \frac{v^2}{2c^2} \right) \quad \dots 15.8.1$$

Eq. (15.8.1) shows that $l < l_0$. Thus the length is contracted and the amount of contraction is given by :

$$(l - l_0) \approx \left| \frac{v^2}{2c^2} \right|$$

We find that when the velocity of the body becomes small, the amount of contraction correspondingly tends to zero and hence can be neglected.

Illustration :

In particle physics, we come across fundamental particles known as muons which are unstable and decay into electron and neutrino. Their mean life-time in a frame in which they are at rest is $2\mu\text{s}$. They are created in the upper atmosphere at a height of $5 \sim 6$ km from the sea-level on interaction of cosmic rays with the atmosphere.

The problem is : Even though the muons are having a short mean life-time, how they are abundantly found at sea-level, crossing such a large distance of $5 \sim 6$ km ?

This can be explained by length contraction. It is found that the velocity of muons is as high as $0.998c$. In the frame of muons, the distance between the birth-place of muons in atmosphere and sea-level =

$$\begin{aligned} l &= l_0 \sqrt{1 - v^2/c^2} \\ &= (6 \times 10^3 \text{ m}) \sqrt{1 - \left(\frac{0.998c}{c}\right)^2} \\ &\approx 379 \text{ meter} \end{aligned}$$

\therefore The time required to travel this distance by muon =

$$\begin{aligned} &\frac{\text{Distance}}{\text{Velocity of muon}} \\ &= \frac{379}{0.998 \times (3 \times 10^8)} \\ &= 1.26 \mu\text{s} \end{aligned}$$

Since this time of $1.26 \mu\text{s}$ is less than the proper life-time of muons ($2 \mu\text{s}$), it is quite possible for the muons to reach the sea-level.

15.9: Time-dilation :

Dilation means "enlargement beyond normal size". In case of time-dilation, we mean that time-interval (between two events) is lengthened. This happens, because time depends on the state of motion of the observer, as per the principles of relativity.

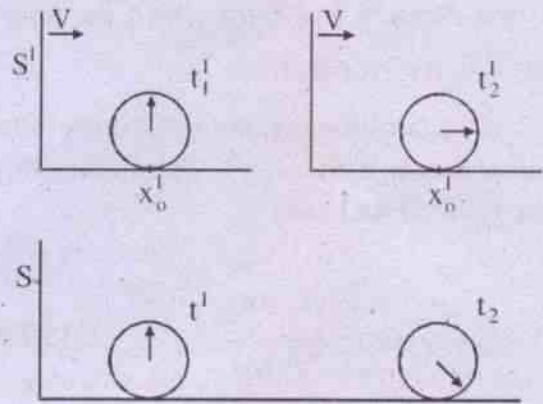

Fig. 15.4

Transformation of time-interval

Remarks :

In S' , the two events take place at the same position (x'_0), at different times (t'_1 and t'_2).

In S , the two events are observed at different positions, which show different times (t_1 and t_2) for the two events respectively.

Consider the frame S' , which is moving with a velocity v along the +ve $x - x'$ axis with respect to the frame S .

Let t'_1 = Time of occurrence of event 1 at point x'_0

t'_2 = Time of occurrence of event 2 at point x'_0 (i.e. the same point as for event 1)

\therefore The time interval between the two events in $S' = t'_2 - t'_1$

$= \Delta t'$ (say) = proper time interval

This time-interval, measured by a **single** clock, at the point of occurrence of events, is called the **proper time interval**. (Normally symbolised by $\Delta\tau$).

Now consider frame S :

Let t_1 = Time of occurrence of event 1 at a point in S.

t_2 = Time of occurrence of event 2 at another point in S.

$$\begin{aligned} \therefore \text{The time-interval in S} &= t_2 - t_1 \\ &= \Delta t \text{ (say)} \\ &= \text{Improper or non-proper time} \end{aligned}$$

The improper time is recorded at different points, other than the point of occurrence of the events. In this case, it will be convenient to use the inverse Lorentz - transformation to link the times in S and S' frames.

$$t_1 = \frac{\left(t'_1 + \frac{vx'_1}{c^2}\right)}{\sqrt{1 - v^2/c^2}}$$

$$\text{and } t_2 = \frac{\left(t'_2 + \frac{vx'_2}{c^2}\right)}{\sqrt{1 - v^2/c^2}}$$

$$\therefore t_2 - t_1 = \frac{(t'_2 - t'_1)}{\sqrt{1 - v^2/c^2}}$$

$$\begin{aligned} \text{or, } \Delta t &= \frac{\Delta t'}{\sqrt{1 - v^2/c^2}} \\ &= \Delta t' \left(1 + \frac{v^2}{2c^2}\right) \quad \dots 15.9.1 \end{aligned}$$

This eqn. (15.9.1) shows that $\Delta t > \Delta t'$. Thus the time has dilated. This proves that the improper time is greater than the proper time.

In fact, the time-interval ($\Delta t'$) is least in the reference frame (here S'), in which the events take place at the same point as registered in the clock there.

The variation of Δt with velocity v is shown in the fig. below :

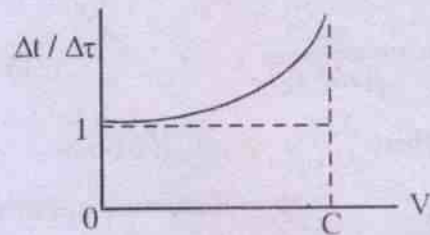

Fig. 15.5
Time dilation

Illustration : (Refer the problems under length contraction)

The life-time of muons is their proper-life, measured in their own frame.

In the laboratory frame, their life-time =

$$\begin{aligned} &\Delta t \text{ (say)} \\ &= \frac{\Delta t'}{\sqrt{1 - v^2/c^2}} \\ &= \frac{2\mu\text{s}}{\sqrt{1 - (0.998)^2}} \\ &= 31.7 \times 10^{-6} \text{ sec.} \end{aligned}$$

In this time, the distance that can be covered by muon = $(31.7 \times 10^{-6})(0.998c)$
= 9.5 km.

Since the distance between the birth place of muon in atmosphere and sea-level is 5-6 km (i.e., much less than 9.5 km), it is quite possible for them to reach sea-level.

15.10: Variation of mass and momentum with velocity :

In Newton's physics mass of a body has been regarded as a constant and independent of its velocity. But in relativity this concept is no

more valid. Relativistic considerations show that when a body is at rest, its mass should be named as 'rest mass' and when it moves, its mass is to be called as its effective mass (or, moving mass). These two masses are being related by the following equation, which shows dependence of m on its velocity :

$$m = \frac{m_0}{\sqrt{1 - v^2/c^2}} \quad \dots 15.10.1$$

Where v = vel. of a body
 m_0 = Rest mass of the body
 m = Effective(moving) mass of the body

When the body is at rest, $v = 0$, so that $m = m_0$

Further when the body is having a velocity c , its mass becomes ∞ .

Thus we find that the mass of a body goes on increasing with its velocity.

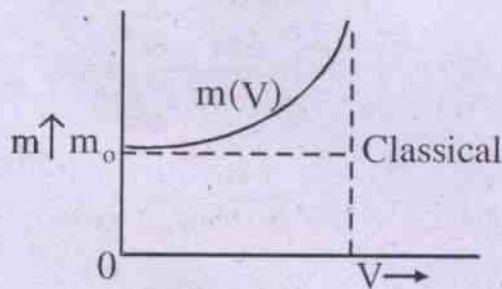

Fig. 15.6

Variation of mass with velocity

From eq(15.10.1), it is simple to write an expression for momentum as :

$P = \text{Momentum} = \text{mass} \times \text{velocity}$

$$= \frac{m_0 v}{\sqrt{1 - v^2/c^2}} \quad \dots 15.10.2$$

and variation of momentum with respect to velocity can be graphically depicted as :

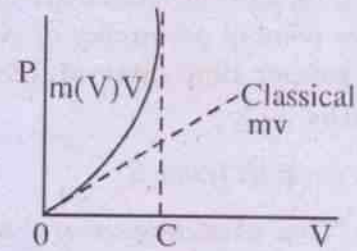

Fig. 15.7

Variation of momentum with velocity

15.11: Expression for force :

By Newton's law, we know that force can be expressed as the rate of change of momentum.

$$\text{Hence } \vec{F} = \frac{d\vec{P}}{dt}$$

In this case, we express \vec{P} relativistically and proceed as :

$$\vec{F} = \frac{d \left[\frac{m_0 \vec{v}}{\sqrt{1 - v^2/c^2}} \right]}{dt} \quad \dots 15.11.1$$

using eq. 15.10.2

If we take \vec{F} and \vec{v} in the same direction, eq. (15.11.1) leads to :

$$\begin{aligned} F &= m_0 \frac{d \left[v \left(1 - v^2/c^2 \right)^{-1/2} \right]}{dt} \\ &= m_0 \left[\frac{dv}{dt} \left(1 - v^2/c^2 \right)^{-1/2} + \left\{ v \cdot \frac{1}{2} \left(1 - v^2/c^2 \right)^{-3/2} \cdot \frac{2v}{c^2} \cdot \frac{dv}{dt} \right\} \right] \\ &= m_0 \frac{dv}{dt} \left[\left(1 - \frac{v^2}{c^2} \right)^{-1/2} + \frac{v^2}{c^2} \left(1 - \frac{v^2}{c^2} \right)^{-3/2} \right] \\ &= m_0 \frac{dv}{dt} \left(1 - \frac{v^2}{c^2} \right)^{-3/2} \left[\left(1 - \frac{v^2}{c^2} \right) + \frac{v^2}{c^2} \right] \end{aligned}$$

$$= m_0 \left(1 - \frac{v^2}{c^2}\right)^{-3/2} \frac{dv}{dt}$$

$$= m_0 \left(1 - \frac{v^2}{c^2}\right)^{-3/2} a \quad \dots 15.11.2$$

where $\frac{dv}{dt}$ = (Acceleration of the body) = a (say)

Whereas in classical physics, force is a product of mass and acceleration, this is not so, in case of relativistic consideration, as seen from eq. (15.11.2).

15.12: Mass-energy Relation :

From the principle of conservation of energy, we know that the work done by a force acting on a body appears as an increase in kinetic energy.

Increase in kinetic energy = work done

i.e., $dT = F ds$

$$\therefore T = \int_{v=0}^{v=v} F ds$$

$$= \int_0^v \frac{d(mv)}{dt} ds$$

$$= \int_0^v \frac{d(mv)}{dt} \frac{ds}{dt} dt$$

$$= \int_0^v \frac{d(mv)}{dt} v dt$$

$$= \int_0^v v d(mv)$$

$$= \int_0^v v d \left\{ \left(\frac{m_0}{\sqrt{1 - v^2/c^2}} \right) v \right\}$$

$$= m_0 \int_0^v \left[\frac{1}{\sqrt{1 - v^2/c^2}} dv + \frac{v^2/c^2}{\left(1 - \frac{v^2}{c^2}\right)^{3/2}} dv \right]$$

$$= m_0 \int_0^v \frac{\left(1 - \frac{v^2}{c^2}\right) + \frac{v^2}{c^2}}{\left(1 - v^2/c^2\right)^{3/2}} dv$$

$$= m_0 \int_0^v \frac{v dv}{\left(1 - v^2/c^2\right)^{3/2}}$$

$$= m_0 c^2 \int_0^v \frac{v dv}{c^2 \left(1 - v^2/c^2\right)^{3/2}} \quad \dots 15.12.1$$

But we know

$$d \left[\left(1 - \frac{v^2}{c^2}\right)^{-1/2} \right] = \frac{v dv}{c^2 \left(1 - v^2/c^2\right)^{3/2}} \quad \dots 15.12.2$$

Sustituting (15.12.2) in (15.12.1), we have

$$T = m_0 c^2 \left[\left(1 - \frac{v^2}{c^2}\right)^{-1/2} \right]_0^v$$

$$= m_0 c^2 \left[\left(1 - \frac{v^2}{c^2}\right)^{-1/2} - 1 \right]$$

$$= c^2 \left[\frac{m_0}{\sqrt{1 - v^2/c^2}} - m_0 \right] \quad \dots 15.12.3$$

$$= c^2 (m - m_0) \quad \dots 15.12.4$$

Eq. 15.12.3 is the relativistic equation for kinetic energy, which can be rewritten as :

Kinetic energy = (Increase in mass) (C^2)
...15.12.5

From eq. 15.12.4, we have :

$$T = mc^2 - m_0c^2 \quad \dots 15.12.5$$

i.e., Kinetic energy =

Total energy - Rest energy

or, Total energy =

Kinetic energy + Rest energy

Which is symbolically, $E = T + E_0$...15.12.6

Substituting (15.12.5) in (15.12.6) and putting the value of E_0 :

$$\begin{aligned} E &= (mc^2 - m_0c^2) + m_0c^2 \\ &= mc^2 \quad \dots 15.12.7 \end{aligned}$$

Eq. (15.12.7) is the well-known Einstein mass-energy relation which gives the universal equivalence between mass and energy.

Let us analyse eq.(15.12.3) in more detail :

$$\begin{aligned} T &= m_0c^2 \left[\frac{1}{\sqrt{1-v^2/c^2}} - 1 \right] \\ &= m_0c^2 \left[\left(1 + \frac{1}{2} \frac{v^2}{c^2} + \frac{3}{8} \frac{v^4}{c^4} + \dots \right) - 1 \right] \end{aligned}$$

(by using Binomial theorem) ...15.12.8

When $v \ll c$ (as in case of classical physics), we have from (15.12.8)

$$\begin{aligned} T &= m_0c^2 \left[\frac{1}{2} \frac{v^2}{c^2} \right] \\ &= \frac{1}{2} m_0v^2 \quad \dots 15.12.9 \end{aligned}$$

where moving mass and rest mass become the same v being equal to zero.

The Principle of mass-energy equivalence has been confirmed several times in nuclear physics.

Examples are : Pair-production, nuclear binding energy etc.

15.13: Momentum of a photon :

$$\text{Momentum of a particle} = P = mV \quad \dots 15.13.1$$

$$\text{But energy} = E = mc^2, \text{ so that } m = \frac{E}{c^2} \quad \dots 15.13.2$$

Substituting this eqn. in 15.13.1 :

$$\begin{aligned} \text{Momentum of a particle} = P \\ = \frac{E}{c^2} v \end{aligned}$$

But photon is a particle of light and hence its velocity is the velocity of light c .

$$\begin{aligned} \therefore P &= \frac{E}{c^2} c \\ &= \frac{E}{c} \quad \dots 15.13.3 \end{aligned}$$

Further quantum mechanically, $E = h\gamma$

where γ = frequency of the photon(or, light wave)

Thus eq. (15.13.3) gives :

$$\begin{aligned} P &= \frac{h\gamma}{c} \\ &= h/\lambda \quad \dots 15.13.4 \quad (\because \gamma\lambda = c) \end{aligned}$$

This is the well-known de Broglie eqn.

Ex.15.1: An event occurs at $x = 50\text{m}$, $y = 20\text{m}$, $z = 10\text{m}$ and $t = 5 \times 10^{-8}$ sec. in frame S . What are the space-time coordinates of the event as measured by an observer stationed in frame S' , which is moving relative to S with velocity $0.6c$ along the common $x-x'$ axis.

Soln.

From Lorentz transformation :

$$x' = \frac{x - vt}{\sqrt{1 - v^2/c^2}}$$

Soln.

From eq. (15.7.2) we obtain :

$$t_2' - t_1' = \frac{\left[(t_2 - t_1) - \frac{v}{c^2}(x_2 - x_1) \right]}{\sqrt{1 - v^2/c^2}}$$

For the two events to occur simultaneously in frame S' , we should have $t_2' - t_1' = 0$

$$\therefore \left[(t_2 - t_1) - \frac{v}{c^2}(x_2 - x_1) \right] = 0$$

$$\text{or, } (4 - 8) \times 10^{-8} - \frac{v}{c^2}(48 - 24) = 0$$

$$\text{or, } -4 \times 10^{-8} - \frac{24}{c} \left(\frac{v}{c} \right) = 0$$

$$\text{or, } \frac{6}{c} \left(\frac{v}{c} \right) = -10^{-8}$$

$$\therefore \frac{v}{c} = \frac{-10^{-8}}{6} c$$

$$= \frac{-10^{-8}}{6} \times (3 \times 10^8)$$

$$(\because c = 3 \times 10^8 \text{ m/sec})$$

$$\text{or, } v = -0.5 \text{ met/sec}$$

Ex.15.5 : A clock keeps correct time. With what speed should it be moved relative to an observer, so that it may seem to lose 4 minutes in 24 hours ?

Soln.

We use the time-dilation formula :

$$\Delta t' = \frac{\Delta t}{\sqrt{1 - v^2/c^2}}$$

We take the clock at rest in a frame S .

$$\begin{aligned} \text{Hence the time } \Delta t &= 24 \text{ hours} - 4 \text{ minutes} \\ &= 23 \text{ hours } 56 \text{ minutes} \\ &= 23.93 \text{ hours} \end{aligned}$$

The observer, relative to whom the frame S is moving with speed v , measures the time as 24 hours.

$$\therefore \Delta t' = 24 \text{ hours}$$

$$\text{Substituting, } 24 = \frac{23.93}{\sqrt{1 - v^2/c^2}}$$

$$\therefore 1 - \frac{v^2}{c^2} = \left(\frac{23.93}{24} \right)^2$$

$$\text{or, } \frac{v^2}{c^2} = 1 - \left(\frac{23.93}{24} \right)^2$$

$$= \left(\frac{47.93}{24} \right) \left(\frac{0.07}{24} \right)$$

$$\text{or, } \frac{v}{c} = \frac{\sqrt{47.93 \times 0.07}}{24} = \frac{1.83}{24}$$

$$\begin{aligned} \text{or, } v &= \frac{1.83}{24} \times (3 \times 10^8) \text{ met/sec} \\ &= 2.3 \times 10^7 \text{ met/sec.} \end{aligned}$$

Ex.15.6 : Find the velocity of a particle at which the mass of the particle is double its rest mass.

Soln.

We use the equation :

$$m = \frac{m_0}{\sqrt{1 - v^2/c^2}}$$

$$\text{Given } m = 2m_0$$

$$\therefore 2 = \frac{1}{\sqrt{1 - v^2/c^2}}$$

$$\text{or, } 1 - \frac{v^2}{c^2} = \frac{1}{4}$$

$$\therefore \frac{v^2}{c^2} = \frac{3}{4}$$

$$\begin{aligned} \text{or, } v &= \sqrt{\frac{3}{4}} c \\ &= 0.86 c \end{aligned}$$

Ex. 15.7: Calculate the energy equivalent to 1 atomic mass unit in million electron-volt. Given Avogadro's Number = 6×10^{23} / g. mol and $c = 3 \times 10^8$ m/sec.

Soln.

$$\begin{aligned} 1 \text{ a.m.u.} &= \frac{1}{6 \times 10^{23}} \text{ gram} \\ &= \frac{1}{6 \times 10^{26}} \text{ kg} \end{aligned}$$

From Einstein's equn.:

$$\begin{aligned} E &= mc^2 \\ &= \left(\frac{1}{6 \times 10^{26}} \right) (3 \times 10^8)^2 \\ &= \frac{9 \times 10^{16}}{6 \times 10^{26}} \text{ joule} \\ &= 1.5 \times 10^{-10} \text{ joule} \\ &= \frac{1.5 \times 10^{-10}}{1.6 \times 10^{-19}} \text{ ev} \\ &= 0.937 \times 10^9 \text{ ev} \\ &= 937 \times 10^6 \text{ ev} \\ &= 937 \text{ Mev} \end{aligned}$$

Ex. 15.8: How much mass is lost when 1 kg of water at 0°C turns to ice at 0°C ? Given latent heat of ice = 80 cal/gm.

Soln.

$$\begin{aligned} \text{Amount of heat lost by water} &= \\ &= \text{Mass} \times \text{Latent heat of ice} \\ &= (1 \text{ kg}) (80 \text{ K.cal / kg}) \\ &= 80 \text{ K. cal} \\ &= 80 \times 4.2 \times 10^3 \text{ joule} \end{aligned}$$

$$\begin{aligned} \text{Equivalent loss in mass} &= \frac{E}{c^2} \\ &= \frac{80 \times 4.2 \times 10^3}{(3 \times 10^8)^2} \\ &= 3.73 \times 10^{-12} \text{ kg} \end{aligned}$$

SUMMARY

1. Galilean-Newtonian Transformation equations :

If S and S' are two frames of references, such that S' is moving along x-axis with constant velocity v, relative to S, then the coordinates of an event in S (x, y, z, t) can be related with those in S' (x', y', z', t') by the following relations:

$$\begin{aligned} x' &= x - vt \\ y' &= y \\ z' &= z \\ t' &= t \end{aligned}$$

Provided the origins of the two frames coincide initially.

2. Michelson-Morley experiment :

This experiment proved that the motion of ether can not be established. Earth's motion through ether cannot be detected.

3. Einstein's Novel idea :

Motion through ether is meaningless; only motion relative to a frame of reference has physical significance. This led to the theory of relativity in two parts :

a. Special theory of Relativity :

It deals with inertial frames of reference. (Here the body is not accelerated, if no force is applied).

b. General theory of Relativity :

It deals with non-inertial frames of reference. (Here the body is accelerated even without the application of force).

4. *Postulates of special theory of Relativity:*

- a. Laws of physics have the same form in all inertial reference frames moving with a constant velocity with respect to one another.
- b. The speed of light has the same value for all observers in different inertial frames of reference.

5. *Lorentz-transformation equations :*

$$x' = \frac{x - vt}{\sqrt{1 - v^2/c^2}}$$

$$y' = y$$

$$z' = z$$

$$t' = \frac{t - vx/c^2}{\sqrt{1 - v^2/c^2}}$$

All conditions remaining same, these equations reduce to Galilean-Newtonian transformation equations, if $v \rightarrow 0$ (i.e., small velocities)

The inverse Lorentz-transformation equations are :

$$x = \frac{x' + vt'}{\sqrt{1 - v^2/c^2}}$$

$$y = y'$$

$$z = z'$$

$$t = \frac{t' + vx'/c^2}{\sqrt{1 - v^2/c^2}}$$

These equations show that the measurement of position and time depends on the frame of reference.

Velocity factor (or, Lorentz factor) =

$$\frac{1}{\sqrt{1 - v^2/c^2}}$$

It is a measure of departure from Newtonian Relativity.

7. *Lorentz-Fitzgerald contraction :*

A body moving with a velocity v relative to an observer appears to be contracted in length by a factor $\sqrt{1 - v^2/c^2}$ in the direction of motion of the object.

Mathematically, $l = l_0 \sqrt{1 - v^2/c^2}$,

where l_0 = proper length.

8. *Time-dilation :*

A clock moving with a velocity v with respect to an observer appears to him to have slowed down by a factor $\sqrt{1 - v^2/c^2}$.

Mathematically, $\Delta t = \frac{\Delta t'}{\sqrt{1 - v^2/c^2}}$

where $\Delta t'$ = proper time-interval

9. *Relativistic addition of velocities :*

Let there be two inertial frames of reference S and S' , out of which S' is moving with a velocity v with respect to S . If u and u' are the velocities of an object w.r.t. the frames S and S' respectively, then :

$$u' = \frac{u - v}{1 - (uv/c^2)}$$

This formula shows that any velocity, added to the velocity of light, gives the velocity of light itself.

For example : if $u = c$, then we get $u' = c$ by using this formula.

Thus the velocity of light is independent of the velocity of the frame of reference, or source or observer.

10. *Relativity of mass :*

Mass of a moving body (m) is dependent on its velocity (v) and is given by

$$m = \frac{m_0}{\sqrt{1 - v^2/c^2}}$$

where m_0 = Rest mass of the body

11. *Relativistic momentum :*

Momentum of a body =

$$P = mv$$

$$= \frac{m_0 v}{\sqrt{1 - v^2/c^2}}$$

12. *Rest mass of photon :*

Momentum of a photon =

$$P = \frac{m_0 v}{\sqrt{1 - v^2/c^2}}$$

But $P = \frac{h}{\lambda}$

Hence $\frac{m_0 v}{\sqrt{1 - v^2/c^2}} = \frac{h}{\lambda}$

which gives $m_0 = \frac{h}{v\lambda} \sqrt{1 - \frac{v^2}{c^2}}$

But for photon $v = c$, so that $m_0 = 0$

13. *Einstein's mass-energy relation :*

Kinetic energy of a body = $T = (m - m_0)c^2$

E = Total energy of a body =

Kinetic energy + Rest energy

$$= T + m_0 c^2$$

$$\therefore E = mc^2$$

14. *Relativistic relation between kinetic energy and linear momentum :*

Total energy = $E = mc^2$

$$= \frac{m_0 c^2}{\sqrt{1 - v^2/c^2}}$$

Linear momentum = $P = mv$,

so that $v = \frac{P}{m}$

Hence $E = \frac{m_0 c^2}{\sqrt{1 - \frac{P^2}{m^2 c^2}}}$

$$= \frac{m_0 c^2}{\sqrt{1 - \frac{P^2 c^2}{m^2 c^4}}}$$

$$= \frac{m_0 c^2}{\sqrt{1 - \frac{P^2 c^2}{E^2}}}$$

$$\therefore E^2 = \frac{m_0^2 c^4}{1 - \frac{P^2 c^2}{E^2}}$$

or $E^2 \left(1 - \frac{P^2 c^2}{E^2}\right) = m_0^2 c^4$

$$\therefore E^2 = m_0^2 c^4 + P^2 c^2$$

MODEL QUESTIONS

A. Multiple Choice Type Questions :

1. The descriptions of motion of a particle is determined by the
 - a) observer
 - b) frame of reference
 - c) nature of motion
 - d) velocity of the particle
2. From a source at rest, light travels out with a velocity equal to 3×10^8 m/sec in vacuum. If the source of light moves towards the observer with a velocity of 1.5×10^8 m/sec, then the relative velocity of light w.r.t. the observer is
 - a) 4.5×10^8 m/s
 - b) 1.5×10^8 m/s
 - c) 3×10^8 m/s
 - d) 4.5×10^{16} m/s
3. In case of the relativistic mass of a particle, which is true
 - a) Increase in mass is due to increase in its P.E.
 - b) Increase in mass is equal to increase in K.E. divided by c^2
 - c) There is no increase in mass
 - d) Mass increases only when $v = 0$
4. According to the theory of relativity, the length of a rod in motion
 - a) is the same as the rest length
 - b) is more than its rest length
 - c) is less than its rest length
 - d) may be more or less than or equal to rest length depending on the speed of the rod.
5. In which of the velocity ranges, the velocity of the particle is inversely proportional to the time elapsed
 - a) Newtonian
 - b) Relativistic
 - c) Ultra relativistic
 - d) None of the above
6. A space-ship in space will have
 - a) clocks running slower than a stationary clock by a factor $\sqrt{1 - v^2/c^2}$
 - b) its length shrunk in the direction of the relative motion by factor of $\sqrt{1 - v^2/c^2}$
 - c) its mass is increased by a factor $\frac{1}{\sqrt{1 - v^2/c^2}}$
 - d) All of the above
7. If the speed of light were $2/3$ of its present value, the energy released in a given atomic explosion will be decreased by a factor of

a) $2/3$	b) $4/9$
c) $5/9$	d) $\sqrt{5/9}$
8. Einstein's mass-energy relation shows that
 - a) Mass disappears to reappear as energy.
 - b) Energy disappears to reappear as mass.
 - c) Mass and energy are two different forms of the same entity.
 - d) All the above statements are correct.

9. The proper length of a space vehicle is ℓ_0 . According to an observer on earth, the length of the space-ship is 25% of its proper length. The speed of the space-ship according to the observer on earth is
- a) $\frac{\sqrt{3}}{2}C$ b) $\sqrt{\frac{3}{2}}C$
 c) $0.968 C$ d) $0.87 C$
10. A proton at rest is accelerated through a high p.d. Speed acquired by proton is 2.5×10^8 m/s. Rest mass of proton is 1.67×10^{-27} kg. The accelerating p.d. is
- a) 7.74×10^6 V b) 74.7×10^6 V
 c) 747×10^6 V d) 0.747×10^6 V
11. "All inertial frames are equivalent". This statement is called the principle of
- a) Equivalence
 b) Correspondence
 c) Relative motion
 d) Inertia
12. In which of the following frames of reference, the acceleration of the particles is zero in the absence of applied force
- a) Inertial b) non-inertial
 c) cartesian d) non-cartesian
13. Two photons recede from each other. Their relative velocity will be
- a) C b) $2C$
 c) $C/2$ d) zero
14. When a material particle of rest mass m attains speed C , its mass becomes
- a) ∞ b) 0
 c) $2m$ d) $4m$
15. At what velocity the kinetic energy of a particle is equal to the rest mass energy
- a) $C/2$
 b) $\sqrt{3}C/2$
 c) $\sqrt{5}C/2$
 d) None of the above
16. On the annihilation of a particle and its antiparticle, the energy released is E . What is the mass of each particle
- a) E/C^2 b) $E/2C^2$
 c) E/C d) $E/2C$
17. Which of the following is not invariant under Galilean transformation
- a) space interval
 b) time interval
 c) mass
 d) momentum
18. A metallic cube of density d moves with a speed $0.8 C$. Its density
- a) decreases
 b) increases
 c) remains unchanged
 d) sometimes decreases and sometimes increases.
19. Which of the following can help an observer to know whether his own frame of reference is at rest or in uniform motion
- a) determination of speed of light
 b) measurement of mass
 c) measurement of time
 d) None of the above
20. A cube has side ℓ_0 when at rest. If the cube moves with velocity v parallel to its one edge, then its volume becomes

a) l_0^3

b) $\frac{l_0^3}{\sqrt{1-(v^2/c^2)}}$

c) $l_0^3 \left[1 - \frac{v^2}{c^2} \right]$

d) $l_0^3 \sqrt{\left(1 - \frac{v^2}{c^2} \right)}$

21. The special theory of relativity shows that the Newtonian Mechanics is valid at

- all velocities
- velocities nearer to that of light
- velocities much smaller than that of light.
- velocities in the ultra-relativistic range

22. A clock keeps correct time on earth. It is put in a space ship travelling with velocity $C/2$. How many hours does it appear to lose in one day

- $12\sqrt{3}$ hours
- $(24 - 12\sqrt{3})$ hours
- 6 hours
- 18 hours

B. Short Answer Type Questions :

- At what speed should a particle move, so that its mass is doubled? Given : velocity of light = 3×10^8 m/sec.
- Under what condition Lorentz transformation and Galilean transformation equations are identical?
- Which experiment confirmed that light does not require a medium for propagation?

- What shape a sphere will appear to have, when it is carried by a very fast-moving person?
- What types of frames of reference are dealt with by the special theory of relativity?
- Why a reference frame attached to the earth is an inertial frame by definition?
- Give basic postulates of the special theory of relativity.
- An electron is chased by a photon. The speed of the electron is $0.9c$. Show that their relative velocity is c .
- A young fat girl dances with high velocity. Explain why she will appear less fat to her stationary friends.
- What is meant by the total energy of a body in special theory of relativity?

C. Numerical Problems :

- A rocket is 100m long on the ground. If its length decreases by 1m to an observer on the ground during its flight, calculate its speed.
- How much younger an astronaut will appear to earth if he returns after one year having moved with velocity equal to $0.5C$?
- Two electrons are moving in opposite directions with velocity $0.6C$ as measured by a laboratory observer. What is the velocity of one electron with respect to the other?
- The half-life of a π -meson at rest is 1.8×10^{-8} sec. What will be its half-life when it will travel with a speed $C/2$?
- How much energy will be released from annihilation of 1kg of matter?
- A space ship is launched from earth's surface with a velocity $0.3C$. It fires a rocket with velocity $0.6C$ relative to space away from earth. What is the velocity of rocket observed from earth's surface? In the above case, calculate the velocity as observed from rocket surface.

7. A 10m long rod is at rest in x-y plane of S frame and makes an angle $\tan^{-1} \frac{3}{4}$ with x-axis. Find the length of the rod as seen in S' frame, which moves with a velocity $0.6C$ w.r.t. S frame along x-axis.
8. Find the relativistic length of an object of rest length 1m moving with velocity $0.6C$ in the direction of motion as well as perpendicular to it.

D. Long Answer Type Questions :

- Describe an experiment, which confirmed that light does not require a medium for propagation. Give necessary theory.
- What are the postulates of special theory of relativity ? Write Lorentz Transformation equation and using them explain length contraction.
- Explain, using Lorentz equations, simultaneity, time-dilation and relativistic velocity addition.
- Explain, with mathematical formula, variation of mass with velocity and mass-energy relation.
- State and explain Galilean transformation equations. What are the consequences of these equations ?
- Explain the following terms associated with relativity :
Event, Observer, Frame of reference, Inertial and non-inertial frame of reference.

E. Answer as directed :

- Mass and energy of the universe are separately conserved according to the theory of relativity. (True/False)
- Two beams of light recede away from each other. What is the relative speed ? (Given, velocity of light is C).
- If the speed of light were $2/3$ of its present value, the energy released in a given atomic explosion will decrease by a factor of _____.
- The kinetic energy of a particle is double of its rest mass energy. Then what is the dynamic mass of the particle in terms of rest mass m_0 ?
- A photon of frequency 10^{16} HZ, has a mass of _____ kg. (Given $h = 6.63 \times 10^{-34}$ Joule sec, $C = 3 \times 10^8$ met/sec)

F. Correct the following sentences.

- The description of motion of a particle is determined by the observer.
- Relativistic mass variation is given by $m = m_0/(1-v^2/c^2)$.
- In relativity the relation between total energy (E), rest mass (m_0), linear momentum (P) and speed of light (c) is $E^2 = m_0^2 C^2 + P^2 C^2$.
- A rod of proper length (l_0), moving with speed (v) appears to have length l given as $l = l_0(1-v^2/c^2)$.
- Under Galilean transformation momentum is invariant.

16

Atomic Physics

16.1: Atomic Models :

Atomic models are proposals regarding the structure of an atom. After the discovery of electron by J.J. Thomson towards the end of the nineteenth century, all the atomic models had to be designed, such that :

- 1) Atom is neutral, i.e., the positive charge is equal to the negative charge inside an atom.
- 2) All atoms must contain electrons.

Basing on these facts, Thomson suggested an atomic model, which says that :

- 1) Atom is like a sphere of radius of about 10^{-10} meters
- 2) The positive charges are distributed inside the sphere uniformly.
- 3) The negatively charged electrons are arranged within the sphere in such a way (much like plums in a pudding) that their mutual repulsions are exactly balanced by the force of attraction towards the centre of the sphere.

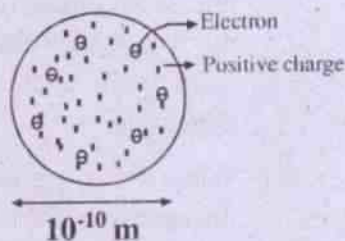

Fig. 16.1

[Thomson's Atomic model : Electrons inside the atom look like black seeds in a waterlemon. This is known as the plum-pudding model].

On the basis of this model, the hydrogen atom should emit a spectral line of 1400 \AA . But experimentally it is found that hydrogen emits four spectral lines in the visible range ($4000\text{-}8000 \text{ \AA}$). This illustrates the failure of Thomson model.

16.2: Alpha Particles Scattering Experiment :

In order to investigate the structure of the atom, Geiger and Marsden in 1911, at the suggestion of Rutherford, Carried out an experiment scattering of α - particles from thin gold foil. (An α - particle is a helium nucleus having a charge $+2e$ and is 8000 times heavier than electron).

A sample that emits α - particles) was placed in a lead cavity, behind a lead plate having a narrow slit. The narrow pencil of α - particles thus obtained was directed at a thin ($6 \times 10^{-7}\text{m}$) gold foil. The scattered α - particles were detected by the flash in zinc sulphide screen fitted to a movable microscope(M). The whole apparatus was arranged inside a vacuum chamber to avoid scattering of α - particles from air molecules.

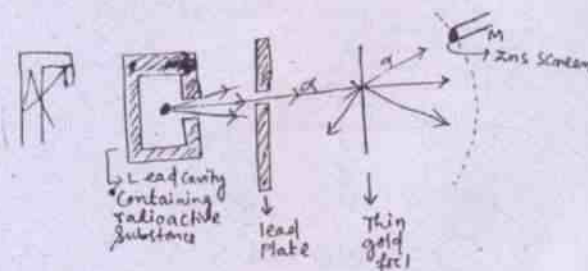

Fig. 16.2

Observations:

- 1) Most of the α -particles passed through the gold foil without any appreciable deviation.
- 2) A small fraction of α -particles was deviated through large angles and some were even scattered by 180° .

The experimental findings regarding angular distribution of scattered α -rays can be graphically illustrated as :

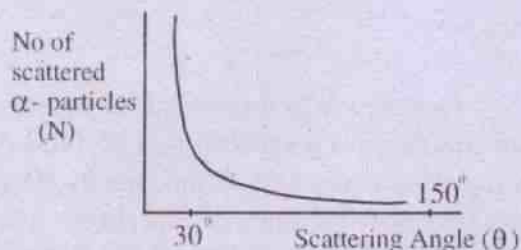

Fig. 16.3 : Scattering of α -particles

[Graph shows relation between scattering angle (θ) and No. of α -particles]

This obeys the mathematical law :

$$N \propto \frac{1}{\sin^4(\theta/2)}$$

where N = No. of scattered α -particles, located at the angle of scattering (θ). Thus N decreases, as θ increases.

The path of the scattered α -particles can be shown as :

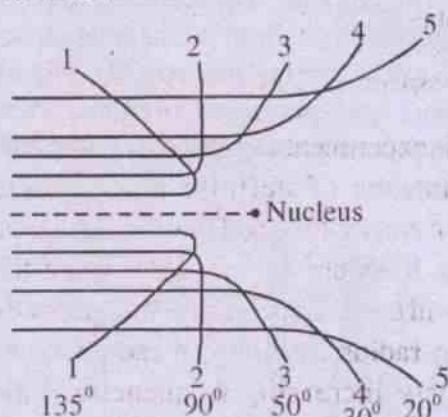

Fig. 16.4

Paths of the scattered particles

Fig. 16.4 shows that the α -particles close to the nucleus are deflected through a large angle.

The trajectory traced by an α -particle depends on the impact parameter b' which is the distance of the initial direction of α -particle and the centre of the nucleus.

Rutherford analytically derived an equation relating impact parameter (b) and scattering angle (θ) as :

$$b = \frac{ze^2 \cot\left(\frac{\theta}{2}\right)}{4\pi \epsilon_0 E}$$

Smaller the impact parameter larger is the scattering angle. In case of head-on collision, impact parameter (b) is zero and hence α -particle rebounds back.

Rutherford's findings can be summarised as follows:

- 1) All the positive charges and almost all the mass of the atom is concentrated in a small portion at the centre instead of being spread throughout the volume of the atom. Rutherford called this as nucleus. The electrons can be assumed to be extra nuclear. This nucleus must have detected or even reversed the direction of energetic α -particles.
- 2) The space around the nucleus is practically empty for which most of the α -particles passed through the gold foil with minor or no deflection.
- (c) When the α -particle is at a greater distance from the nucleus, the force between them will be weak as per the inverse square law. Hence the effect of the nucleus will not be appreciable.

- (d) A few α -particles will retrace their path, i.e., the angle of scattering will be 180° . This happens, when the striking α -particle approaches the nucleus straight. However due to the strong repulsive interaction, it travels back being deflected by 180° . This happens when the α -particle is at certain distance from the nucleus while approaching it, denoted by d (Distance of minimum approach) in Fig. 16.5.

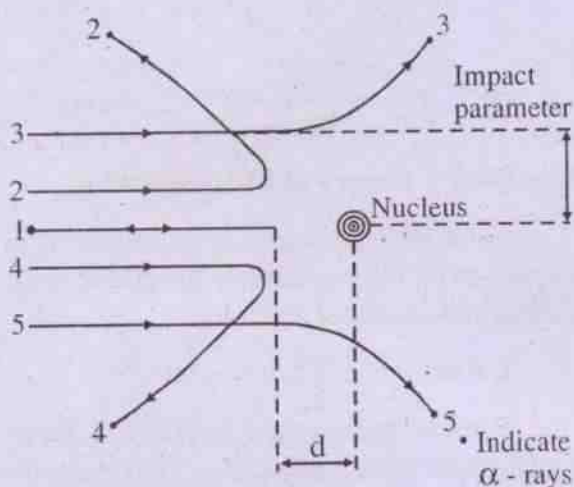

Fig. 16.5

α -ray scattering; Impact Parameter; Distance of minimum-approach

Because the distance of minimum approach is of the order of 10^{-14} m, we conclude that the radius of the nucleus should be less than this. In fact it is of the order of 10^{-15} m.

16.3: Rutherford's model of the atom :

- (1) Each atom has a central core of radius of about 10^{-15} m (one Fermi), containing the entire positive charge of the atom. It is called the nucleus. Since the radius of an atom is about 10^{-10} m, it can be stated that the size of the nucleus is 10^{-5} th part of the atom. Thus the nucleus occupies a very small space in the atom.

- (2) Atom is neutral. Thus the total positive charge at the nucleus is equal to the total negative charge, carried by electrons, which move round the nucleus in orbits - as in the case of planetary systems. The centripetal force arising out of the circular motion is balanced by the electrostatic coulomb force of attraction between the electrons and the nucleus - thus maintaining dynamic equilibrium.

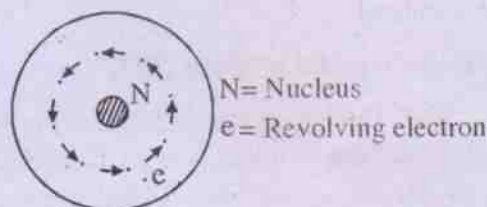

Fig. 16.5 (A)

Rutherford's model of the Atom

16.4: Limitations of Rutherford's Atomic model :

1. Stability of Atom :

In electromagnetic theory we know that any accelerated charge (in this case, electron) must radiate energy continuously. This will result in steady loss of energy of the revolving electrons. Thus the electrons, instead of moving in stationary orbits, will take a spiral path, moving closer and closer to the nucleus and finally falling into it. Thus the stability of the atom is not possible.

2. Discrete spectral lines :

It is experimentally found that elements emit radiations of definite and discrete wavelength and frequency. However such type of spectral lines are not possible, when the electrons will be revolving in orbits of gradually decreasing radius resulting in radiations of continuously increasing frequencies. This drawback is due to the fact that Rutherford's model is using the laws of classical physics.

3. Similarity between atoms of an element :

We know that atoms of an element are identical in all respects. But, as per the Rutherford's model, there is complete freedom for electrons to move in any orbit of their choice. Hence there is no guarantee that the orbits, occupied by the electrons in one atom, will be the same for the electrons of another atom-even if they belong to the same element. This would mean that all the atoms of an element would not be identical.

16.5: Bohr's model of atom (1913) :

Niels Bohr accepted the planetary model of Rutherford; but he not only used the classical laws of physics; but also some quantum principles.

He adopted the following postulates :

(1) The electrons of an atom revolve around a centrally located nucleus in certain privileged/ permitted circular orbits. The electrostatic coulomb force between the nucleus and the electron provides the necessary centripetal force, so that dynamic equilibrium is maintained. The electrons do not radiate energy while in their permitted orbits.

2. Bohr's quantisation condition :

The electrons revolve only in those orbits for which the angular momentum is some

integral multiple of $\frac{h}{2\pi}$.

$$\text{i.e.; } L = mvr = n \frac{h}{2\pi} \quad \dots\dots 16.5.1$$

Where h is Planck's Constant and n is an integer.

Eq. (16.5.1) also shows that even though classically all the orbits are possible for an electron, the electron will choose and revolve in those orbits, for which the quantum condition, specified in this eqn. is satisfied. This means that out of all orbits, only a few are chosen for

electron-motion, emphasizing thereby that these orbits are privileged.

3. When an electron jumps from a higher orbit to a lower orbit, radiation of energy takes place.

Mathematically,

$$\text{Energy emitted} = E = E_i - E_f$$

where E_i and E_f represent the energies of the two orbits such that $E_i > E_f$

But by Planck's law, $E = h\nu$

$$\therefore h\nu = E_i - E_f \quad \dots 16.5.5$$

$$\text{or, } \nu = \frac{E_i - E_f}{h} \quad \dots 16.5.6$$

16.6: Bohr's Theory of hydrogen atom :

Bohr chose hydrogen-atom, which is the simplest of atoms, containing one proton in its nucleus and one outer electron.

1. Radius of electronic orbit

Consider an electron of mass m and charge ' e ' revolving round a nucleus of charge (+ve) with a velocity (V_n) in n th orbit having radius r_n .

The required centripetal force is obtained from the electrostatic attraction between electron and nucleus.

$$\therefore \frac{mV_n^2}{r_n} = \frac{1}{4\pi\epsilon_0} \frac{e^2}{r_n^2} \quad \dots 16.6.1$$

But from basic postulate, (quantisation condition)

$$mV_n r_n = n \frac{h}{2\pi}$$

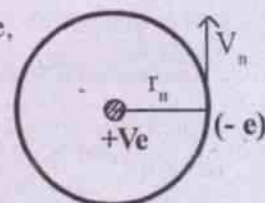

...(eq:16.5.1)

$$\Rightarrow V_n = \frac{nh}{2\pi m r_n} \quad \dots 16.6.2$$

Using equation (ii) in eq. (i)

$$m \left(\frac{nh}{2\pi m r_n} \right)^2 = \frac{1}{4\pi\epsilon_0} \frac{e^2}{r_n}$$

$$\Rightarrow \frac{n^2 h^2}{4\pi m r_n} = \frac{e^2}{\epsilon_0}$$

$$\text{or } r_n = \frac{\epsilon_0 n^2 h^2}{\pi m e^2} \quad \dots 16.6.3$$

This eqn. gives the radius of the n th orbit of the hydrogen atom. This indicates that

$$r_n \propto n^2 \quad \dots 16.6.4$$

i.e. as n increases, the radius also increases.

2. Velocity of Electrons:

From eq. (16.5.1), we have

$$v_n = \frac{nh}{2\pi m r_n}$$

Substituting the value of r_n from eq (16.6.3) above, we obtain

$$v_n = \frac{e^2}{2\epsilon_0 nh} \quad \dots 16.6.5$$

$$\text{i.e. } v_n \propto \frac{1}{n} \quad \dots 16.6.6$$

Hence when the number of orbit increases, the velocity of the electron revolving in the orbit decreases.

3. Total energy of the electron:

By using the above equations, it is possible to calculate the energy of any electron, revolving in an orbit. We write :

Total energy of an electron in the n th orbit

$$= (E_n)_{\text{kinetic}} + (E_n)_{\text{potential}} \quad \dots 16.6.7$$

$$\text{But } (E_n)_{\text{kinetic}} = \frac{1}{2} m v_n^2$$

$$= \frac{1}{2} m \left(\frac{e^2}{2\epsilon_0 nh} \right)^2$$

by using eq.(16.6.5)

$$(E_n)_{\text{kinetic}} = \frac{m e^4}{8\epsilon_0^2 n^2 h^2} \quad \dots 16.6.8$$

Further

$(E_n)_{\text{potential}} =$ Work done in bringing the electron from ∞ to a point x in the orbit.

$$= \int_{\infty}^{r_n} (\text{Force}) (\text{distance})$$

$$= \int_{\infty}^{r_n} \left(\frac{e^2}{4\pi\epsilon_0 x^2} \right) (dx)$$

$$= \frac{e^2}{4\pi\epsilon_0} \left[-\frac{1}{x} \right]_{\infty}^{r_n}$$

$$= -\frac{e^2}{4\pi\epsilon_0} \cdot \frac{1}{r_n}$$

$$= -\frac{e^2}{4\pi\epsilon_0} \left(\frac{\pi m e^2}{\epsilon_0 n^2 h^2} \right)$$

by eq.(16.6.3)

$$= -\frac{m e^4}{4\epsilon_0^2 n^2 h^2} \quad \dots 16.6.9$$

Putting eqns. (16.6.8 and 9) in eqn. (16.6.7), we get

$$E_n = \frac{m e^4}{8\epsilon_0^2 n^2 h^2} - \frac{m e^4}{4\epsilon_0^2 n^2 h^2}$$

$$= -\frac{m e^4}{8\epsilon_0^2 n^2 h^2} \quad \dots 16.6.10$$

Thus $E_n \propto -\frac{1}{n^2}$...16.6.11

The -ve sign in eqs. (16.6.10 & 11) indicate that the orbiting electrons are not free; but are bound to the nucleus, due to force of attraction between them. Further as n increases, i.e., as the separation between the nucleus and the electron increases, the attractive force goes on decreasing and, theoretically, it becomes zero, when $n \rightarrow \infty$, i.e., the electron becomes free from the atom (Also known as continuum).

Ground state of the atom refers to the lowest permitted energy level; i.e., for which $n = 1$.

The energy required to bring an electron from its ground state to the continuum is defined as the ionisation energy of the atom.

The states higher than ground state (i.e., $n > 1$) are known as excited states.

Ex. 16.6.1: Find out the radius of the 1st Bohr orbit.

Soln.

From eq. (16.6.3), we have :

$$r_n = \frac{\epsilon_0 n^2 h^2}{\pi m e^2}$$

$$= \left(\frac{\epsilon_0 h^2}{\pi m e^2} \right) n^2$$

Given (in MKS units)

$$4\pi\epsilon_0 = \frac{1}{9 \times 10^9} \text{ C}^2 / \text{Nm}^2$$

$$h = 6.62 \times 10^{-34} \text{ Js}$$

$$m = 9.11 \times 10^{-31} \text{ kg}$$

$$e = 1.6 \times 10^{-19} \text{ C}$$

$$\therefore \frac{\epsilon_0 h^2}{\pi m e^2} = (4\pi\epsilon_0) \frac{h^2}{4\pi^2 m e^2}$$

$$= \left(\frac{1}{9 \times 10^9} \right) \frac{(6.62 \times 10^{-34})^2}{4\pi^2 (9.11 \times 10^{-31})(1.6 \times 10^{-19})^2}$$

$$= \left(\frac{1}{36\pi^2 \times 10^9} \right) \left(\frac{1}{9.11 \times 10^{-31}} \right) \left(\frac{6.62 \times 10^{-34}}{1.6 \times 10^{-19}} \right)^2$$

$$= \left(\frac{1}{355 \times 10^9} \right) \left(\frac{1}{9.11 \times 10^{-31}} \right) (4.14)^2 10^{-30}$$

$$= \frac{(4.14)^2}{355 \times 9.11} \times 10^{-8}$$

$$= \frac{17.14}{3234.1} \times 10^{-8}$$

$$= 5.3 \times 10^{-11} \text{ m}$$

$$\therefore r_n = (5.3 \times 10^{-11}) n^2 \text{ in meter}$$

Putting $n = 1$,

$$r = 5.3 \times 10^{-11} \text{ meter}$$

$$= 0.53 \text{ \AA}$$

Ex.16.6.2: Calculate the velocity of the electron in first Bohr orbit.

Using the eq. (16.6.5),

$$v_n = \left(\frac{e^2}{2\epsilon_0 h} \right) \frac{1}{n}$$

$$\frac{e^2}{2\epsilon_0 h} = \frac{(1.6 \times 10^{-19})^2 (4\pi \times 9 \times 10^9)}{2(6.62 \times 10^{-34})}$$

$$= \frac{(1.6 \times 1.6) 10^{-38} (4 \times 3.14 \times 9) 10^9}{2 \times 6.62 \times 10^{-34}}$$

$$= \left(\frac{16 \times 16 \times 4 \times 3.14 \times 9}{2 \times 6.62} \right) 10^5$$

$$= \frac{289.38}{13.24} \times 10^5$$

$$\therefore v_n = (219 \times 10^5) \frac{1}{n}$$

$$\text{or, } v_1 = (219 \times 10^5) \text{ met/sec } (\because n = 1)$$

Ex.16.6.3: Calculate the energy of the electron in the first Bohr orbit.

Soln.

We have from eq. (16.6.10):

$$E_n = - \left(\frac{me^4}{8\epsilon_0^2 h^2} \right) \cdot \frac{1}{n^2}$$

$$\frac{me^4}{8\epsilon_0^2 h^2} = \frac{9.11 \times 10^{-31} \times (1.6 \times 10^{-19})^4}{8 \times (6.62 \times 10^{-34})^2} \times (4\pi \times 9 \times 10^9)^2$$

$$= \frac{9.11 \times (1.6)^4 \times (4 \times 3.14 \times 9)^2 \times 10^{-89}}{8 \times 6.62 \times 6.62 \times 10^{-68}}$$

$$= \left(\frac{9.11 \times 7.23 \times 12778}{350.6} \right) \times 10^{-21}$$

$$= \frac{841627}{350.6} \times 10^{-21}$$

$$= 2170 \times 10^{-21}$$

$$= 2.17 \times 10^{-18} \text{ Joule}$$

$$= \frac{2.17 \times 10^{-18}}{1.6 \times 10^{-19}}$$

$$(\because 1 \text{ Joule} = \frac{1}{1.6 \times 10^{-19}} \text{ eV})$$

$$= 13.56 \text{ eV}$$

$$\therefore E_n = - \frac{13.56}{n^2} \text{ in eV}$$

$$\text{or, } E_1 = - 13.56 \text{ eV}$$

16.7: Origin of spectral lines :

From eq. (16.5.6), we have

ν = Frequency of radiation

$$= \frac{E_i - E_f}{h}$$

$$\text{But } E_i = - \frac{me^4}{8\epsilon_0^2 h^2} \left(\frac{1}{n_i^2} \right)$$

$$\text{and } E_f = - \frac{me^4}{8\epsilon_0^2 h^2} \left(\frac{1}{n_f^2} \right) \quad \dots 16.7.1$$

where n_i and n_f represent the initial and final quantum numbers respectively, showing the jump of the electron between the initial and final orbits. ($n_i > n_f$, which means more excited to less excited state)

Substituting (16.7.1) in (16.5.6), we get :

$$\nu = \frac{1}{h} \left[- \frac{me^4}{8\epsilon_0^2 h^2} \left(\frac{1}{n_i^2} - \frac{1}{n_f^2} \right) \right]$$

$$= \frac{me^4}{8\epsilon_0^2 h^3} \left(\frac{1}{n_f^2} - \frac{1}{n_i^2} \right) \quad \dots 16.7.2$$

This equation gives the frequency of the photon (i.e., quantum of light energy), released by electron-jump, when it transits from the final to the initial state.

Since c = velocity of light

$$= \nu \lambda$$

$$\text{We have } \nu = \frac{c}{\lambda}$$

$$= \frac{me^4}{8\epsilon_0^2 h^3} \left(\frac{1}{n_f^2} - \frac{1}{n_i^2} \right)$$

$$\text{or, } \frac{1}{\lambda} = \frac{me^4}{8\epsilon_0^2 ch^3} \left(\frac{1}{n_f^2} - \frac{1}{n_i^2} \right) \quad \dots 16.7.3$$