

1

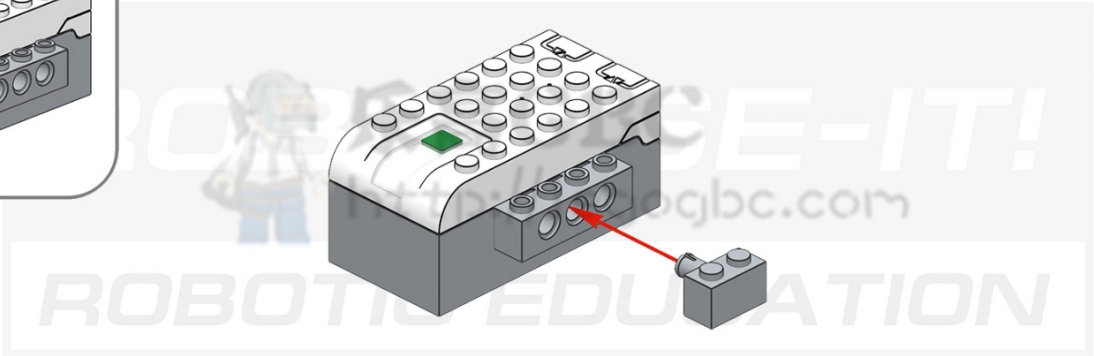

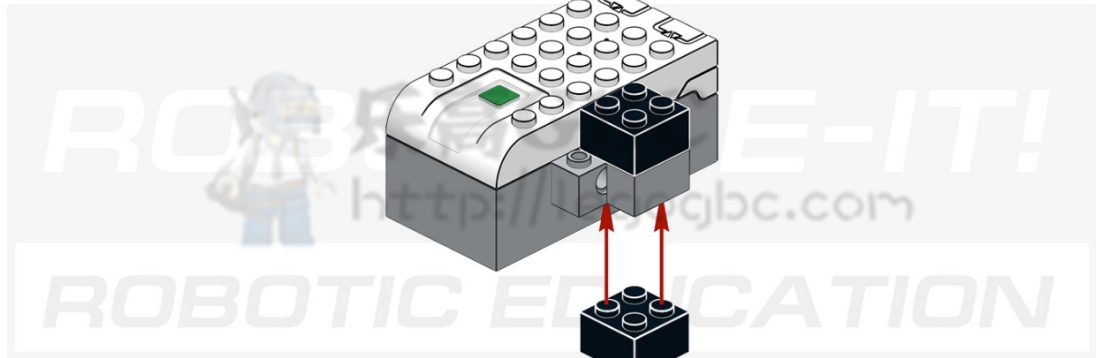

2



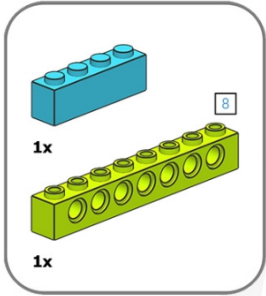

3

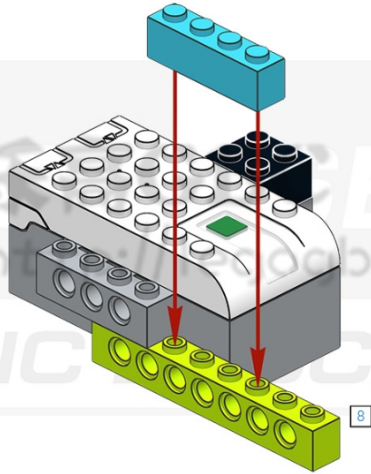

ROBOTIC EDUCATION

ROBOTS-IT!

http://www.robots-education.com

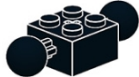

1x

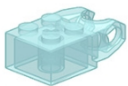

2x

1

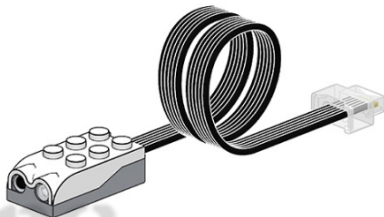
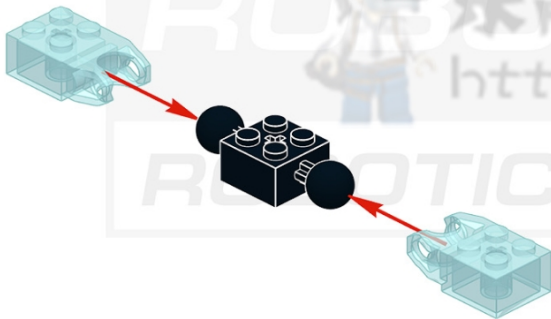

1x

2

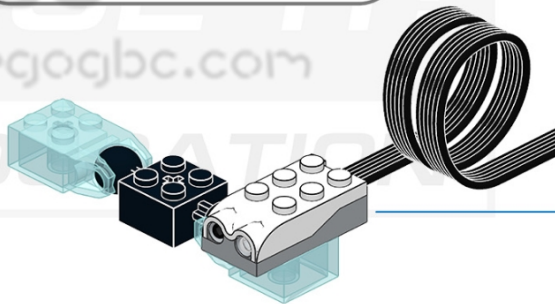

5

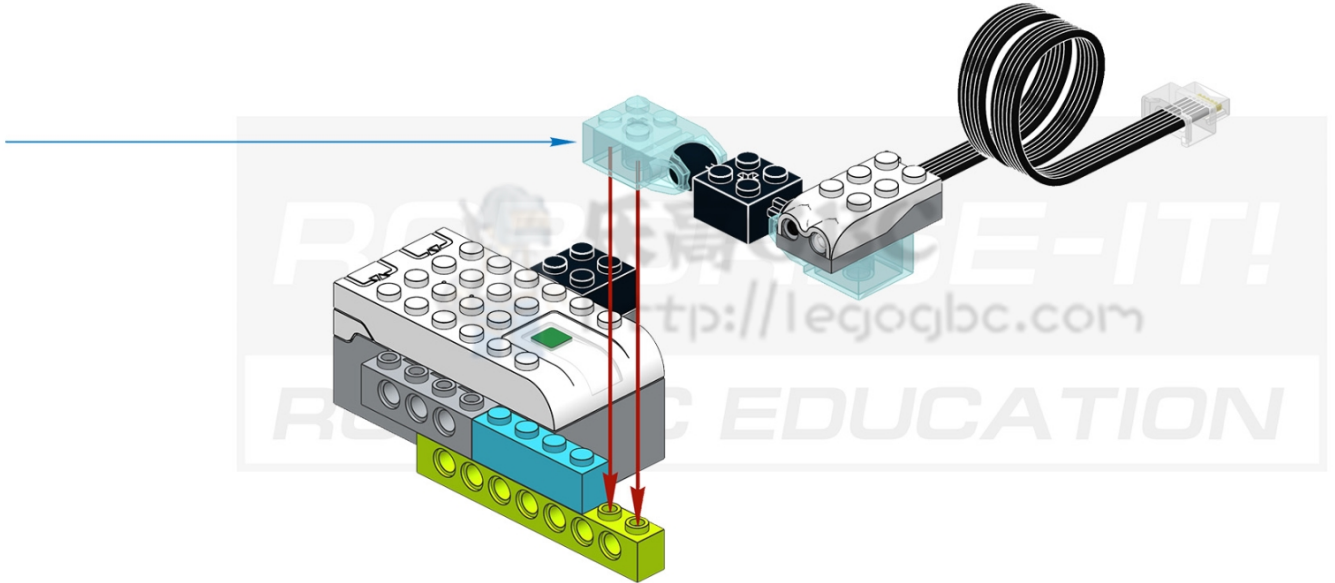

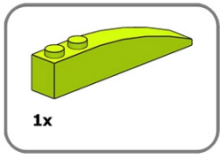

6

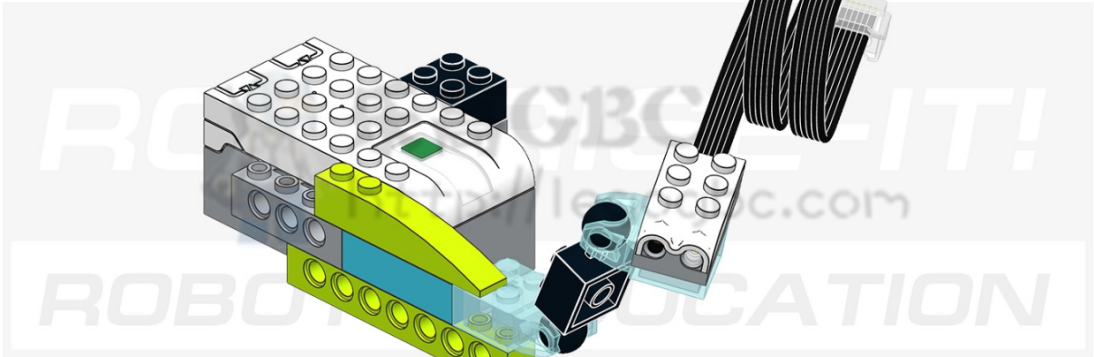

7

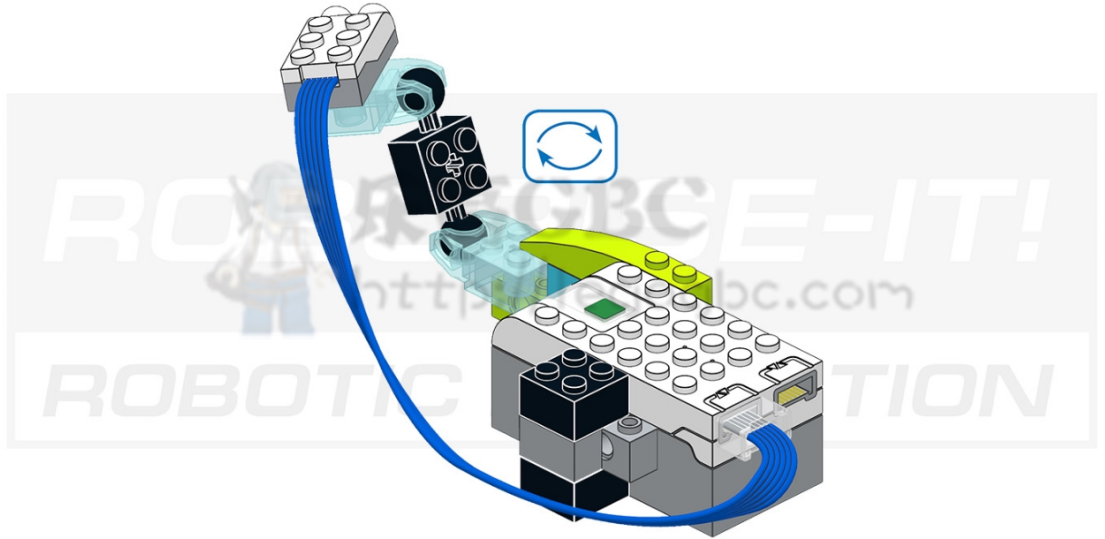

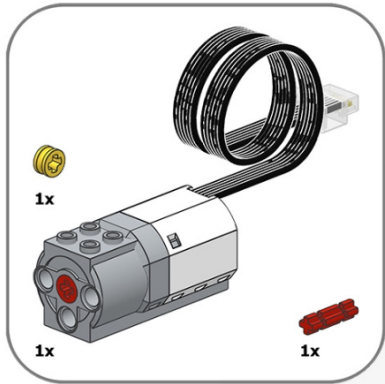

8

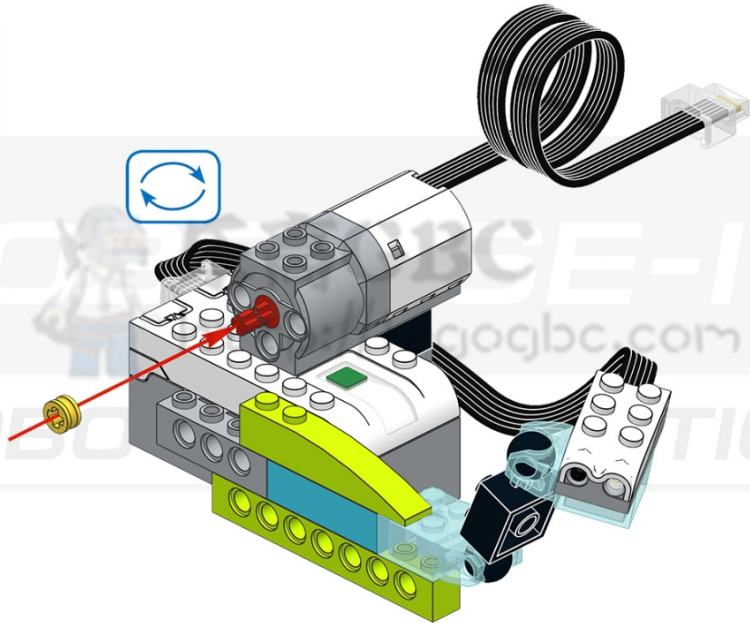

9

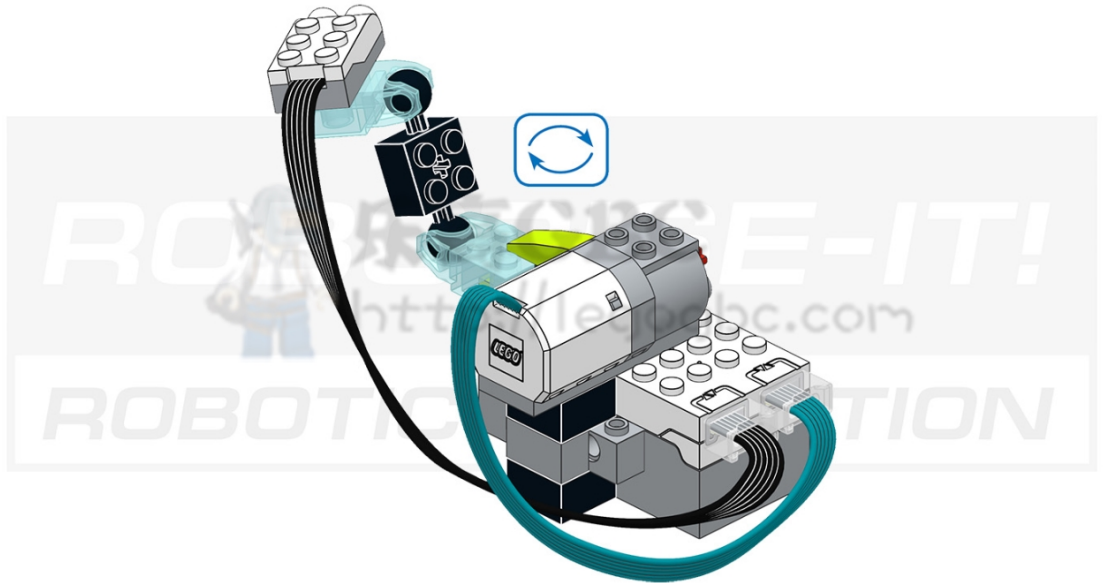

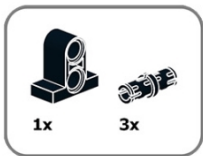

10

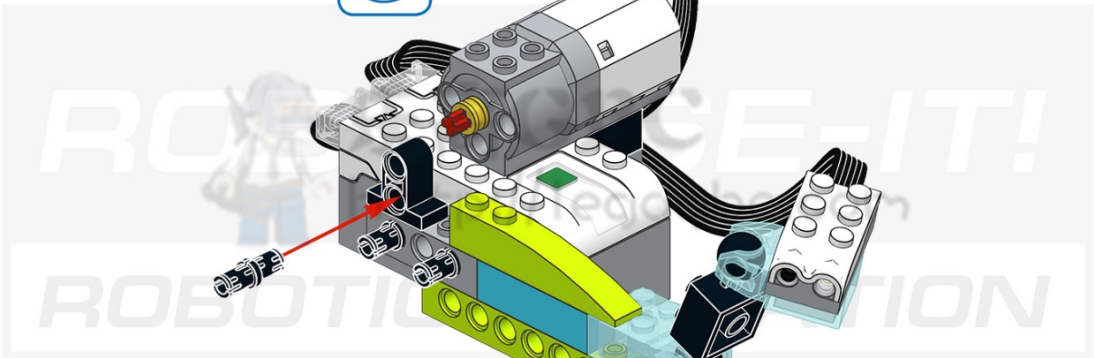

ROBOTICS
ROBOTIC
ROBOTIC

11

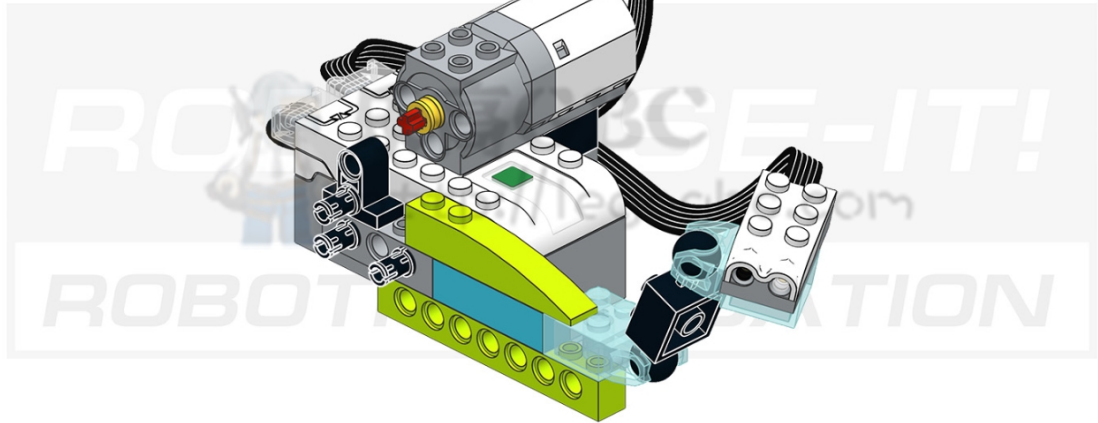

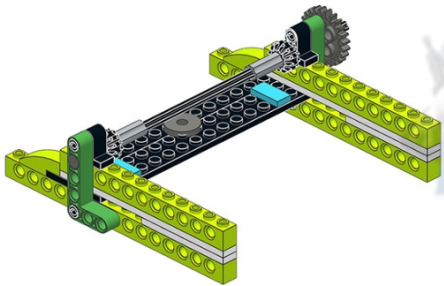

12

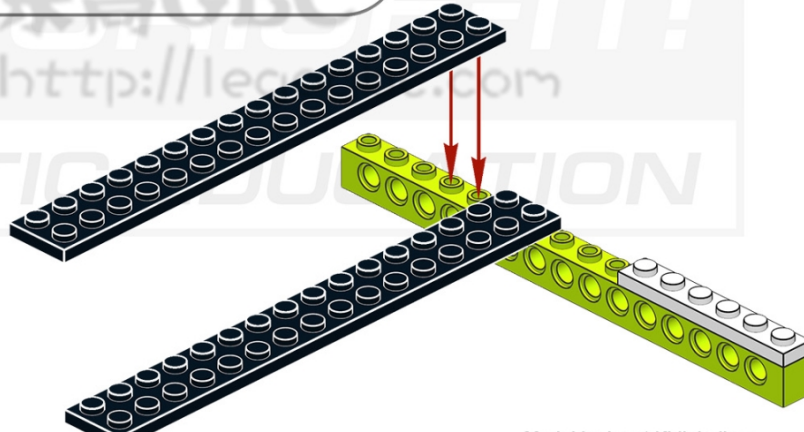
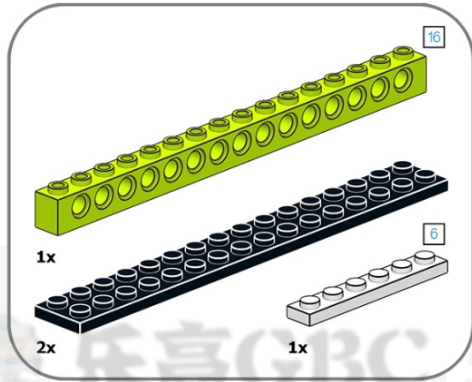

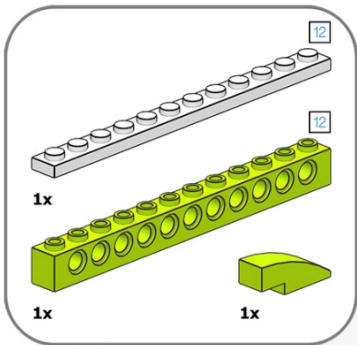

13

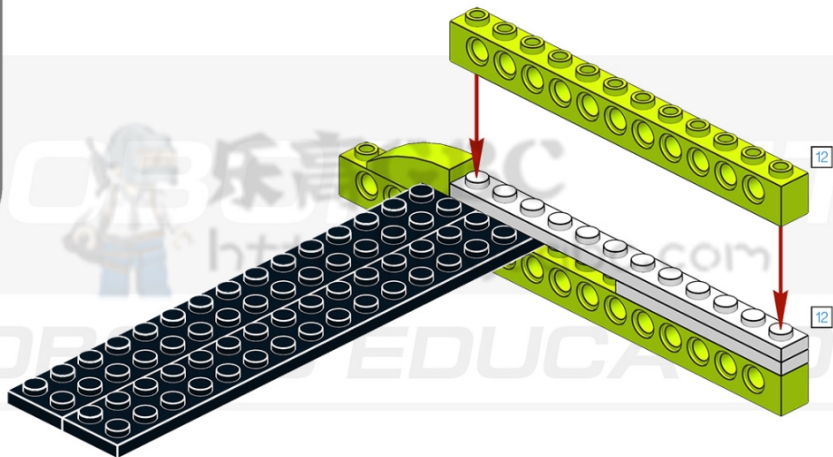

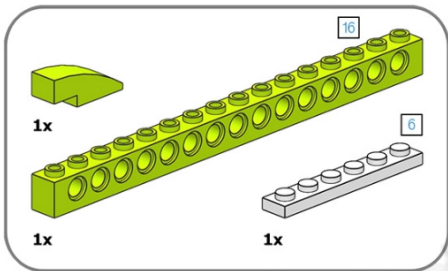

14

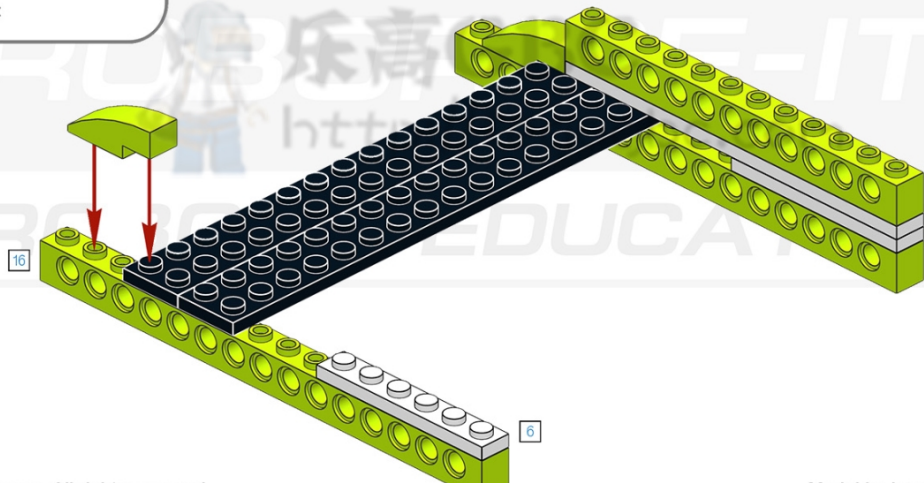

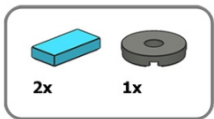

15

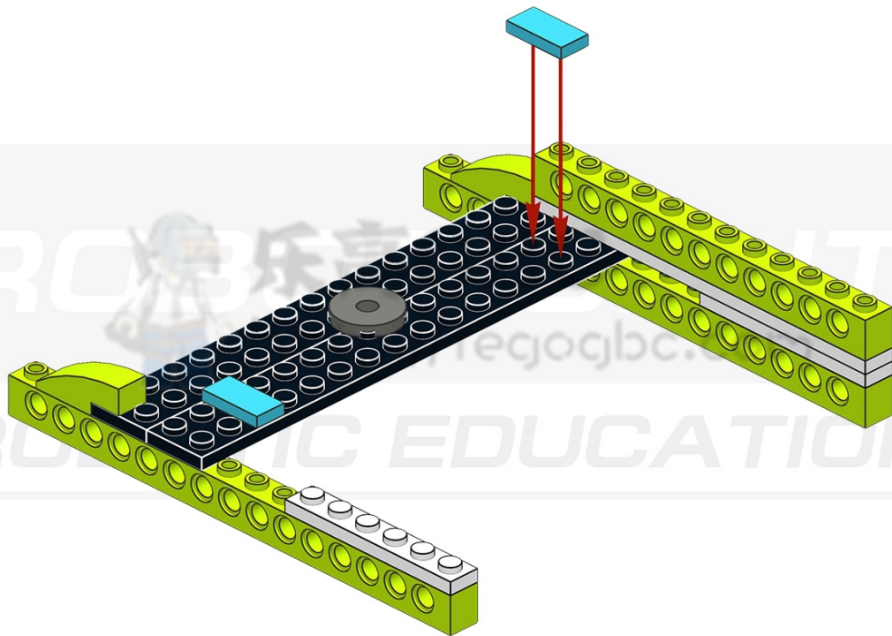

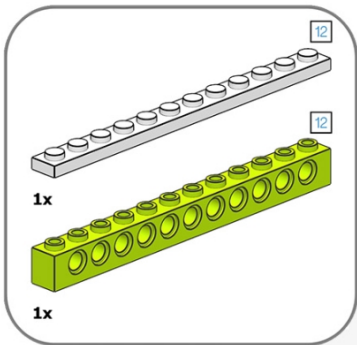

16

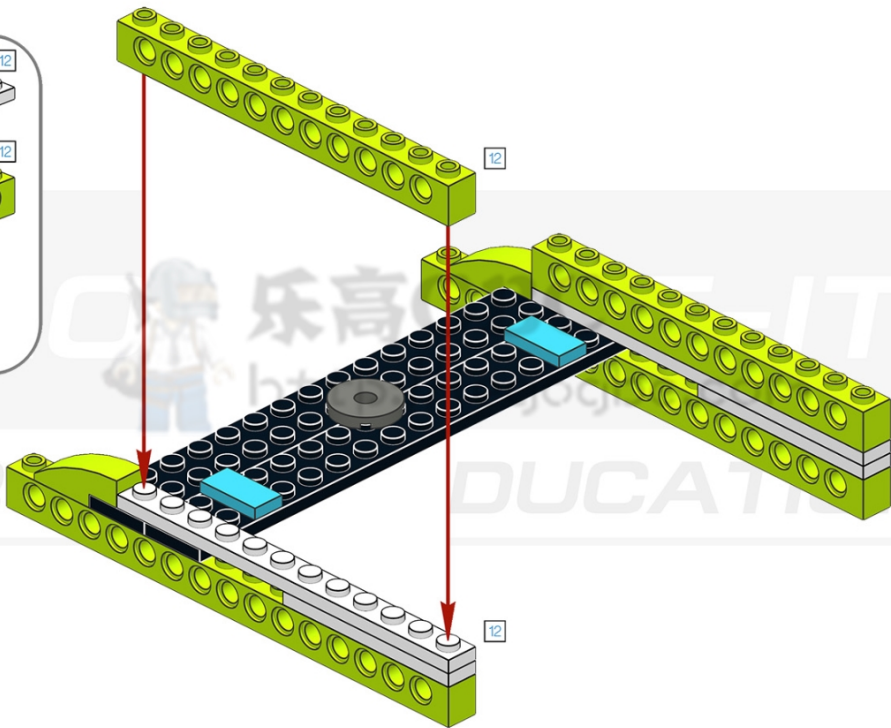

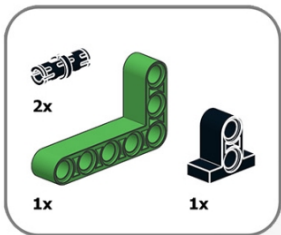

17

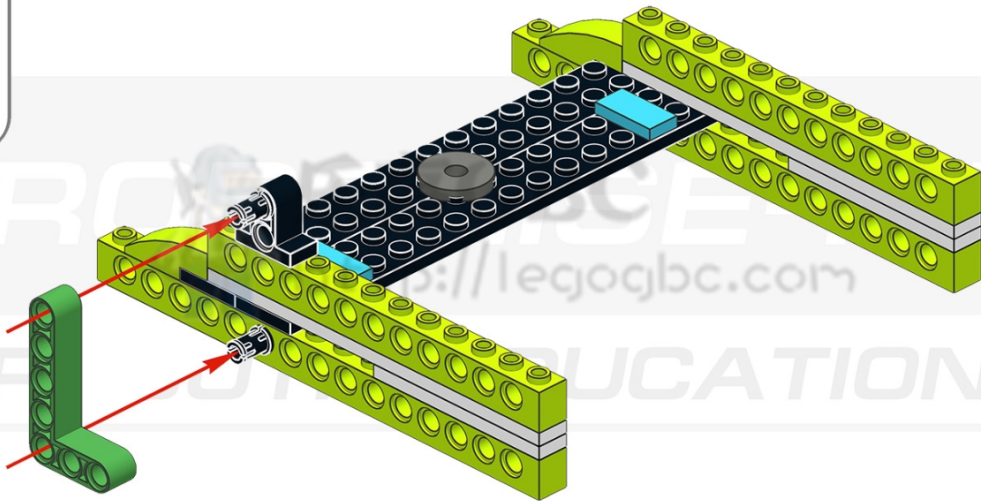



18

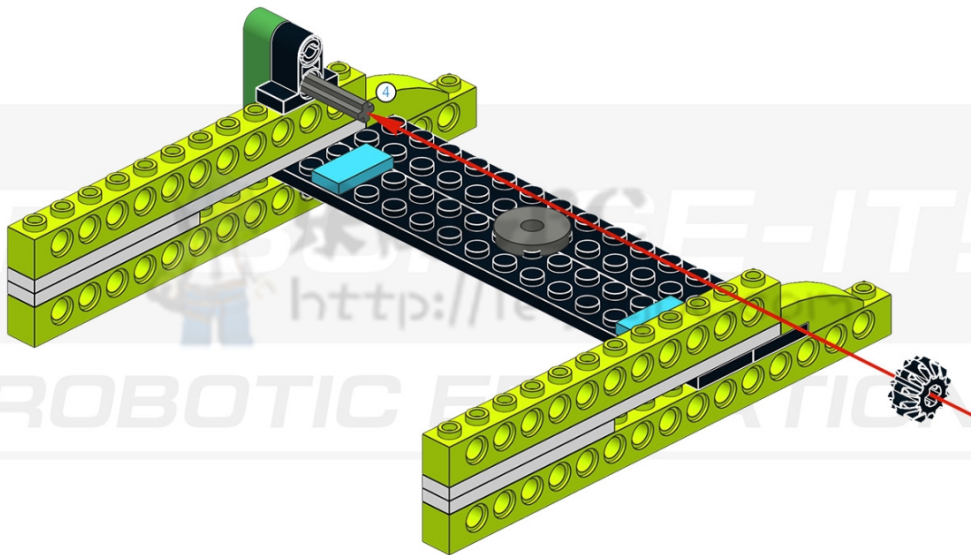

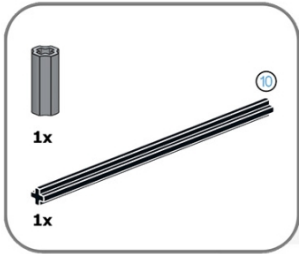

19

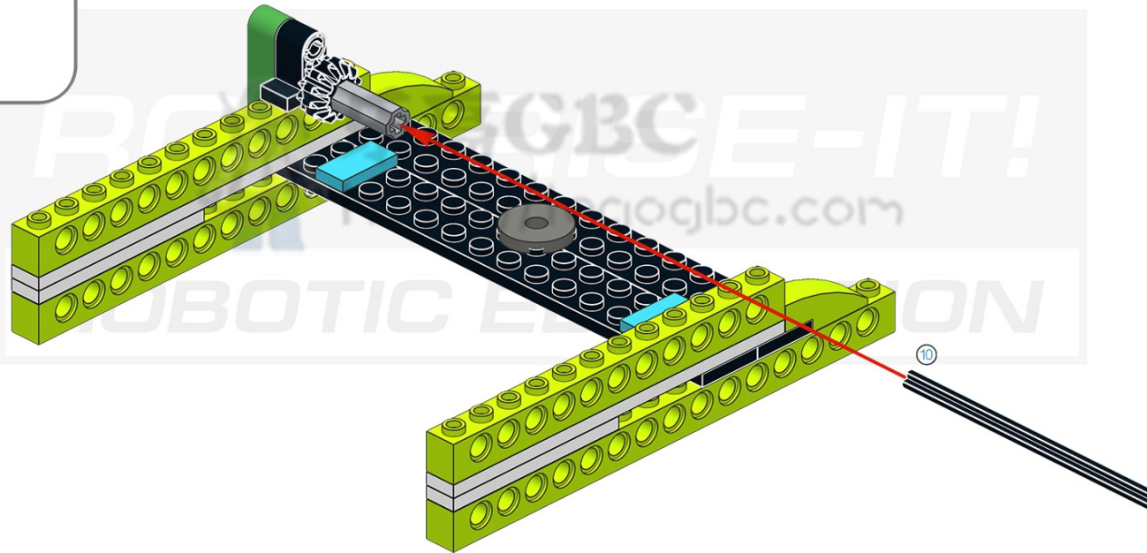



20

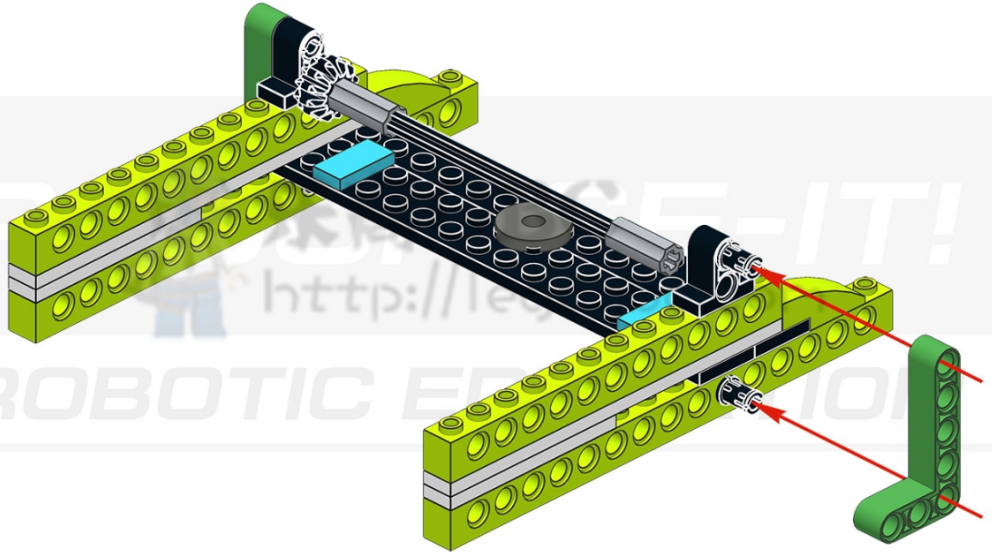

ROBOTIC EDUCATION

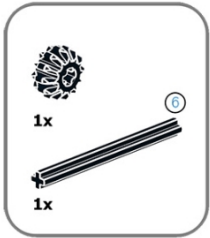

21

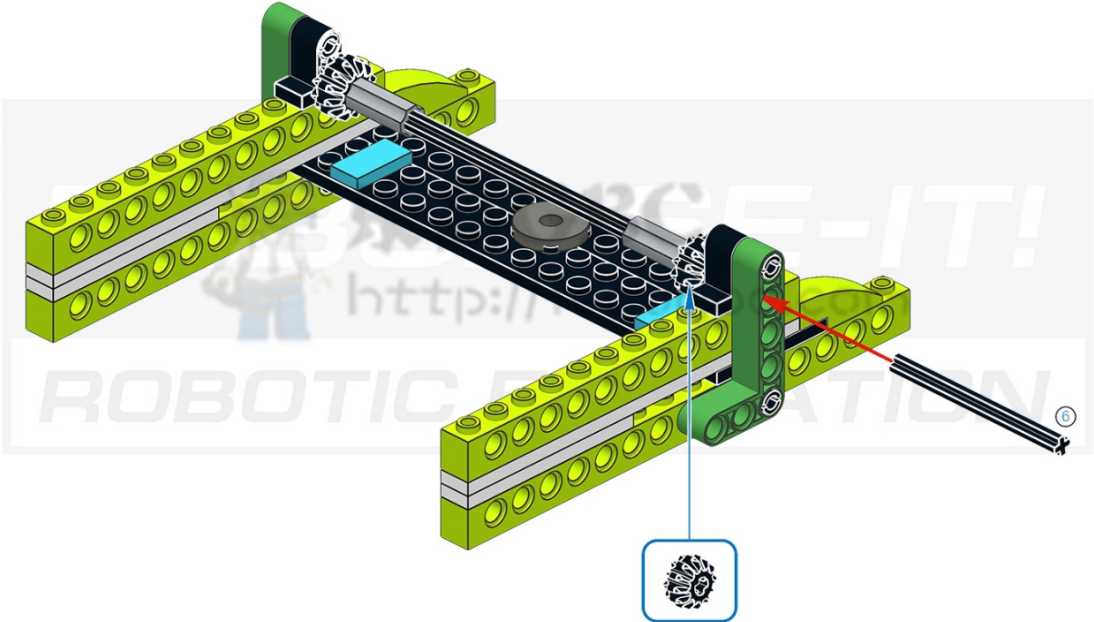



22

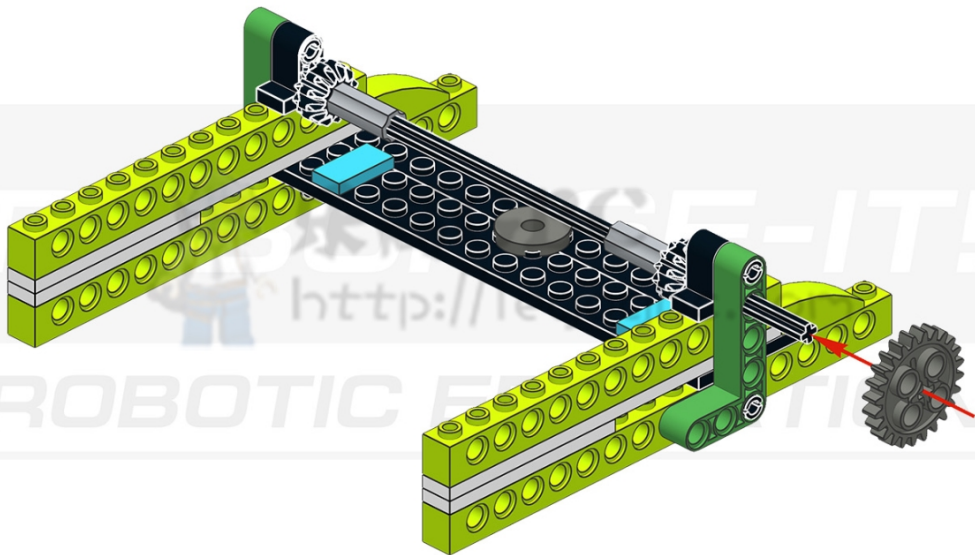

23

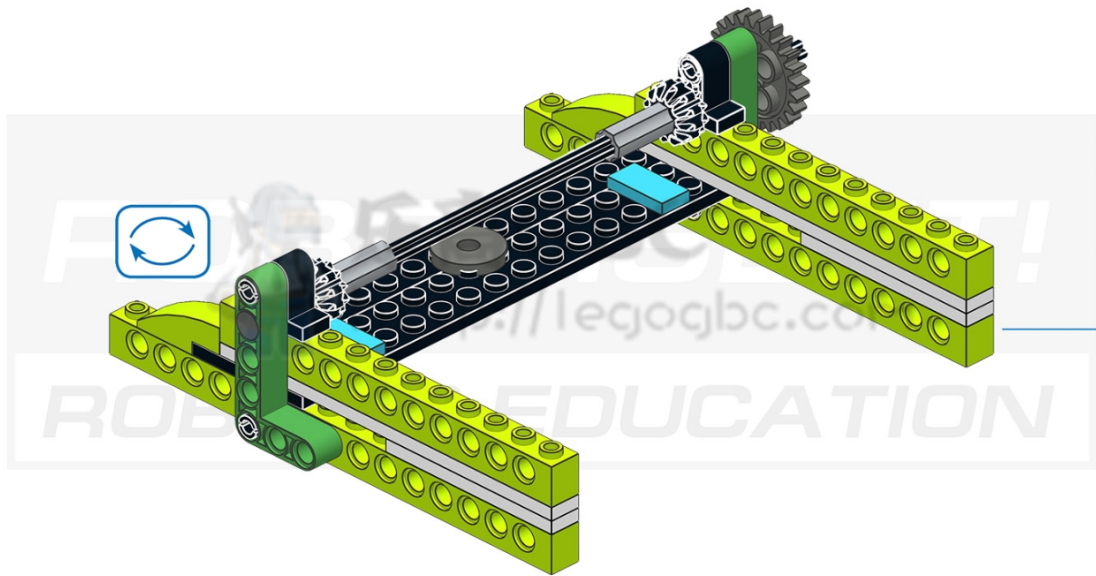

24

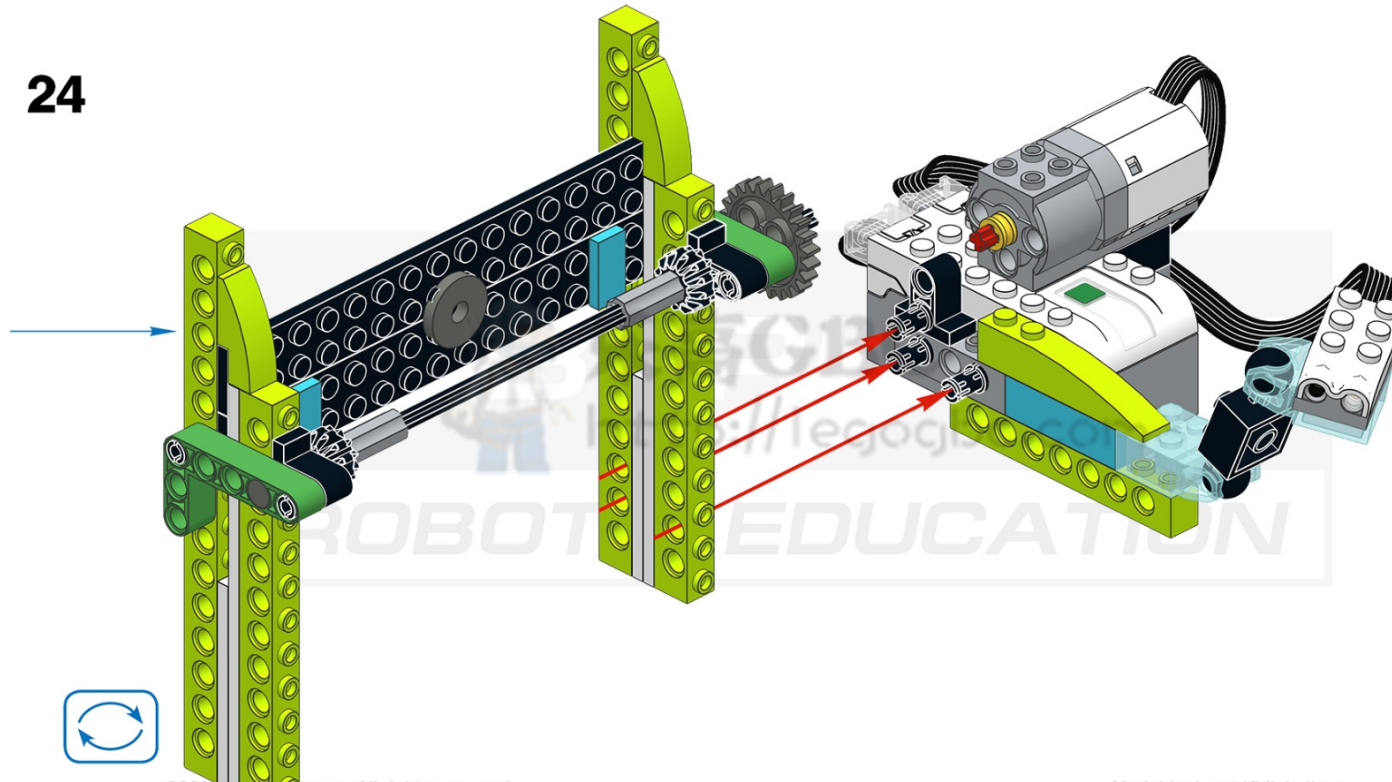

25

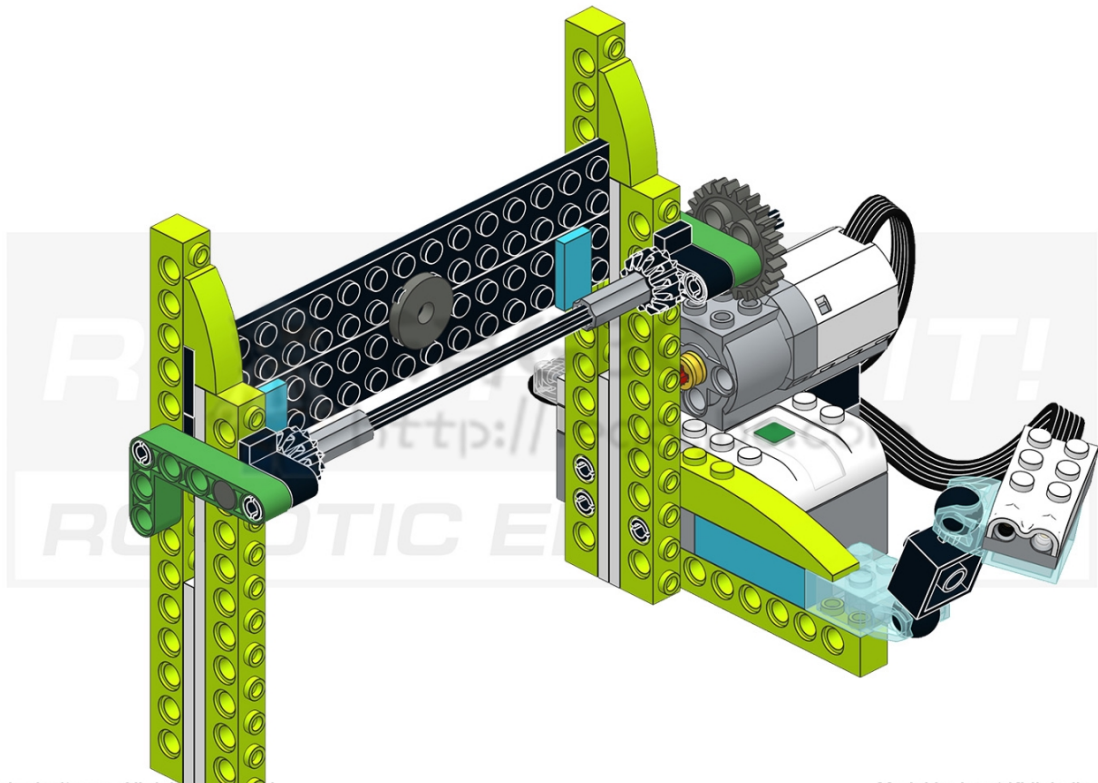

1x 2x

1

2

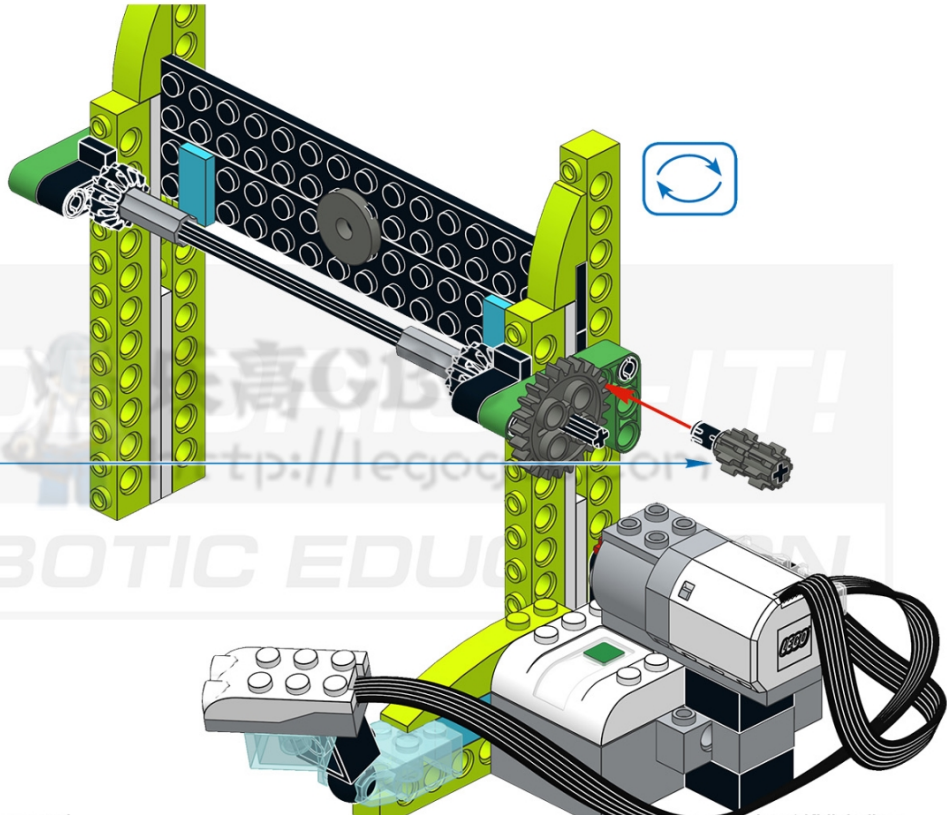

27

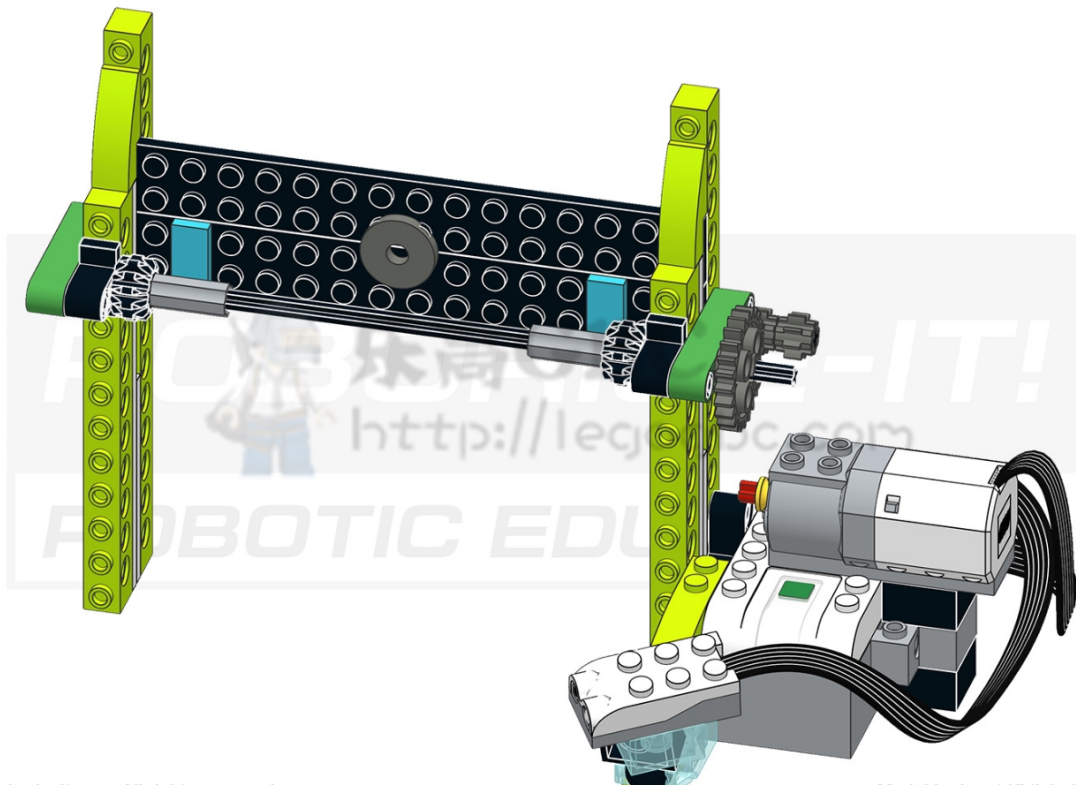



28

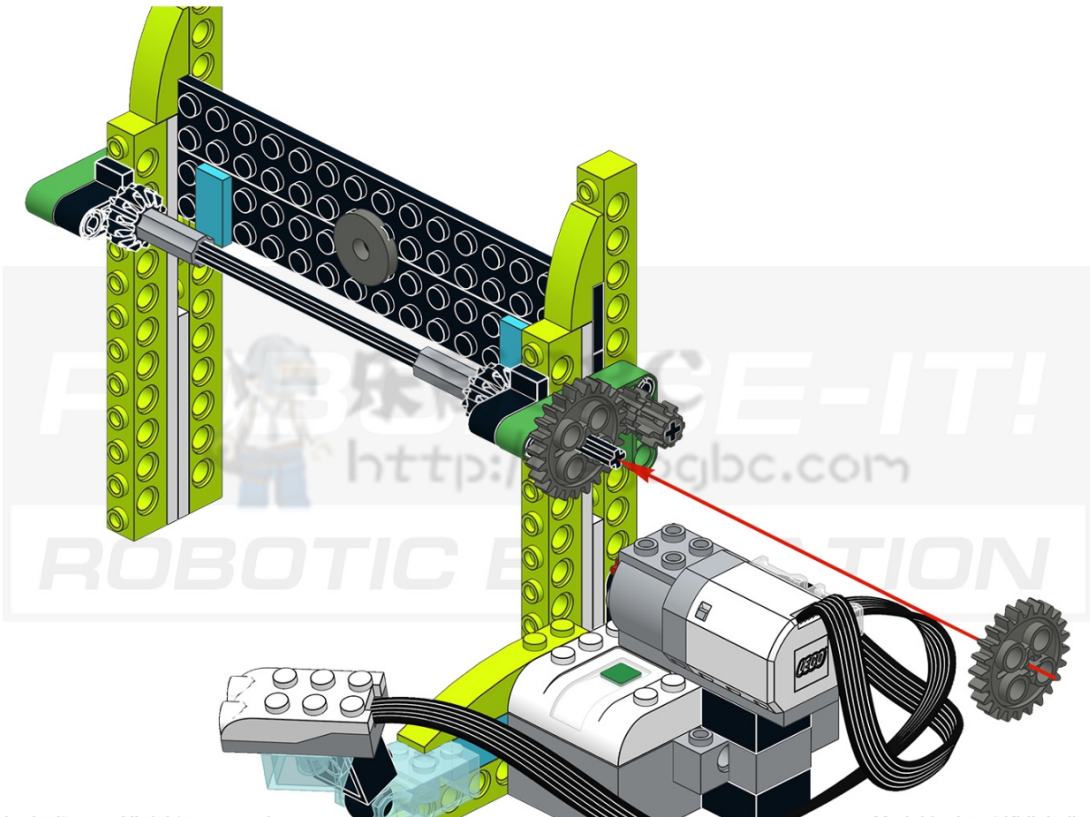

29

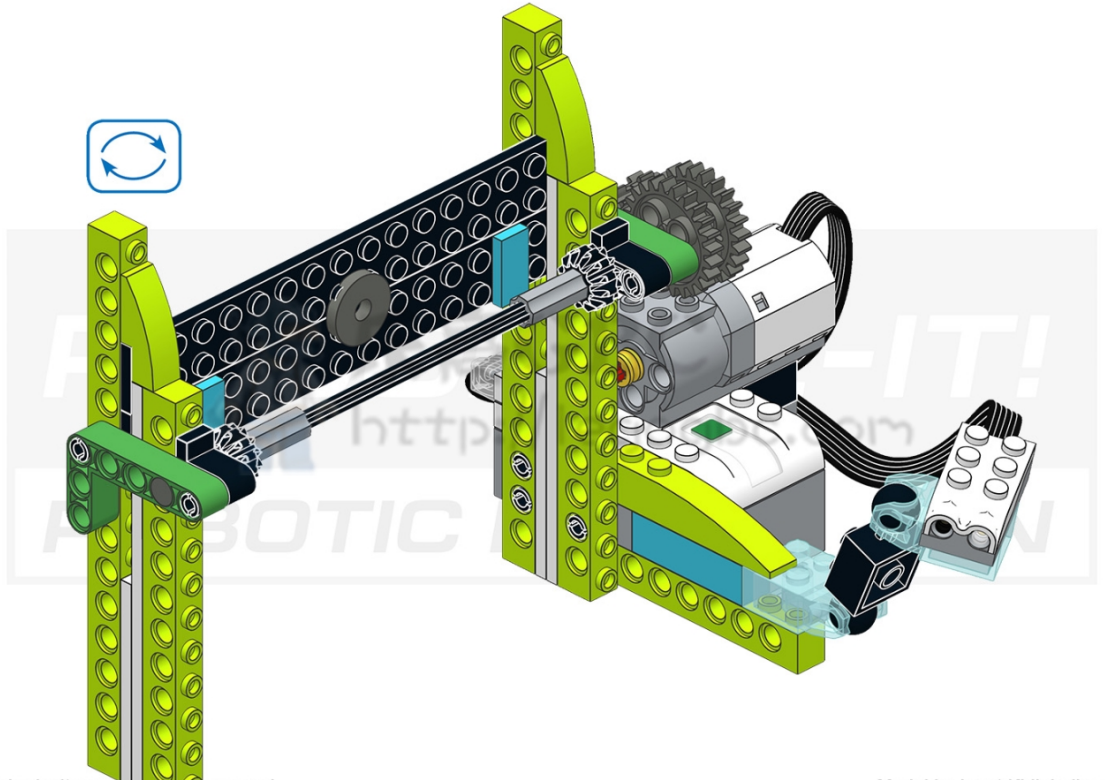

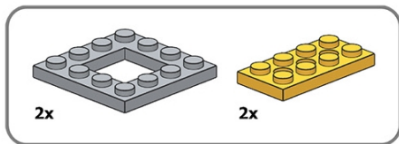
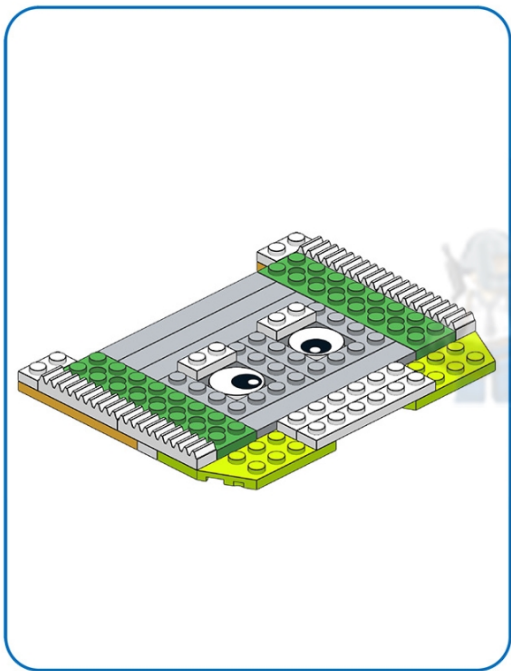

30

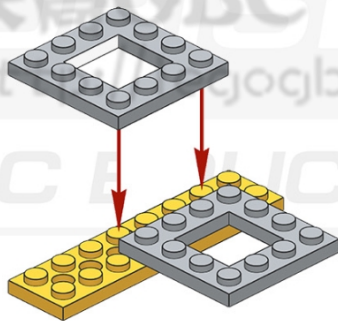

乐高GBC E-IT!
http://www.jogbc.com
ARTIC REPLICATION

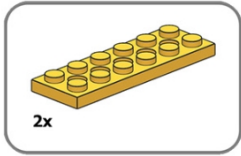

31

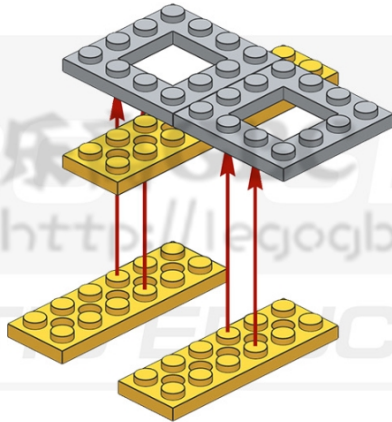

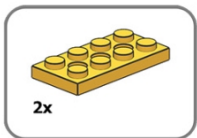

32

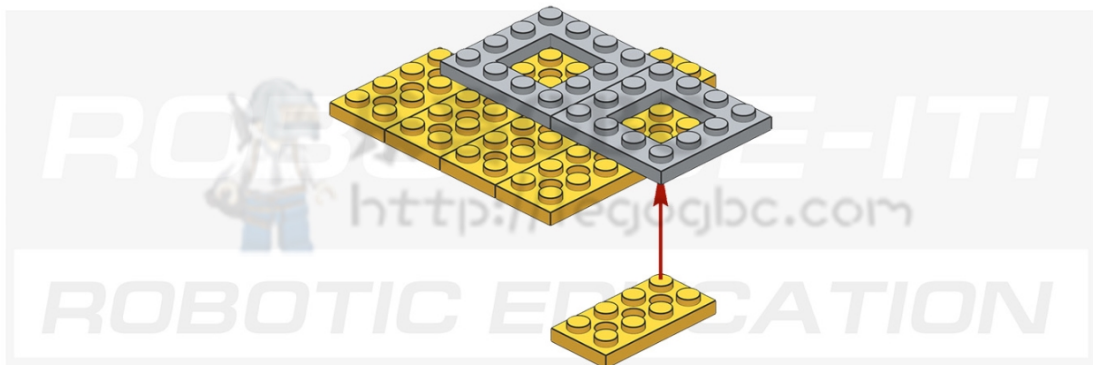

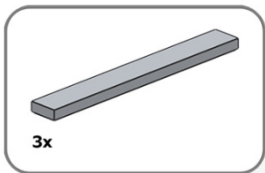

33

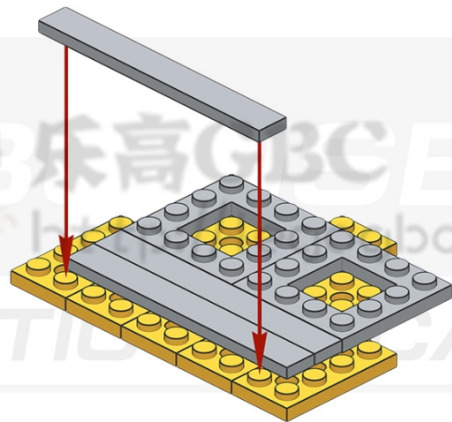

ROBOTICS
ROBOTIC EDUCATION

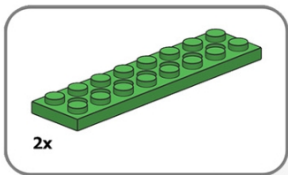

34

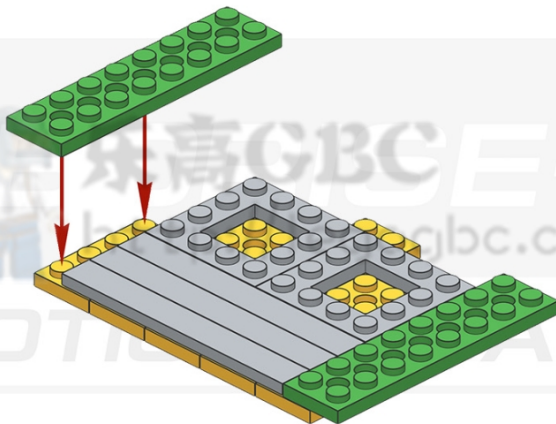

ROBO高GBC E-IT!
gbc.com
ROBOTIC INNOVATION

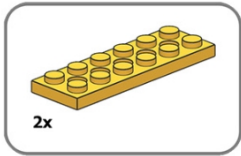

35

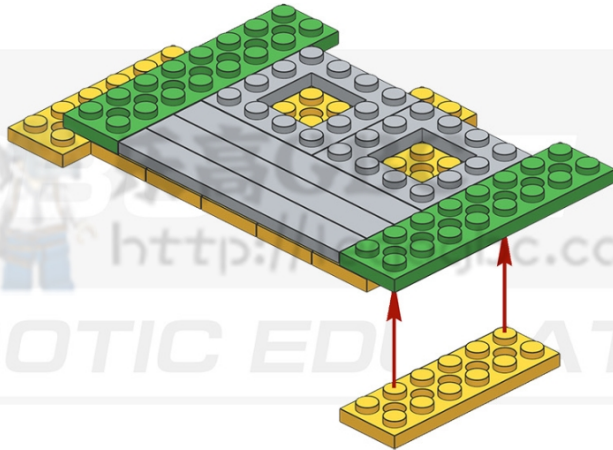

ROBOTIC EDUCATION

<http://www.roboticeducation.com>

ROBOTIC EDUCATION

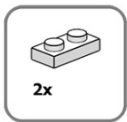

36

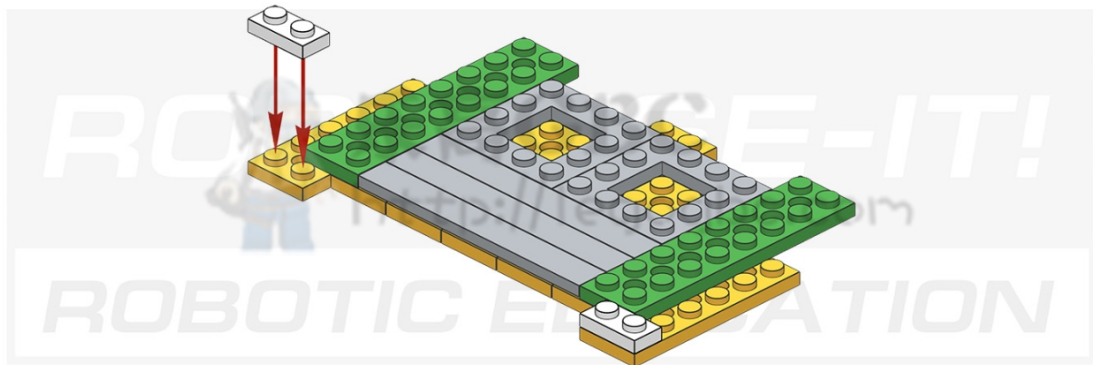

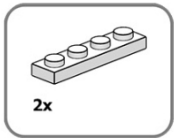

37

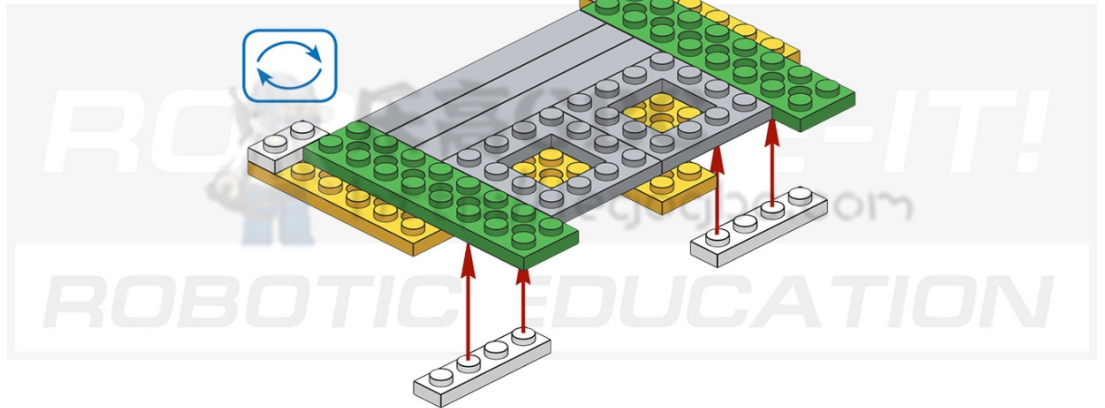

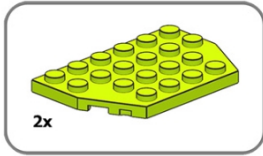

38

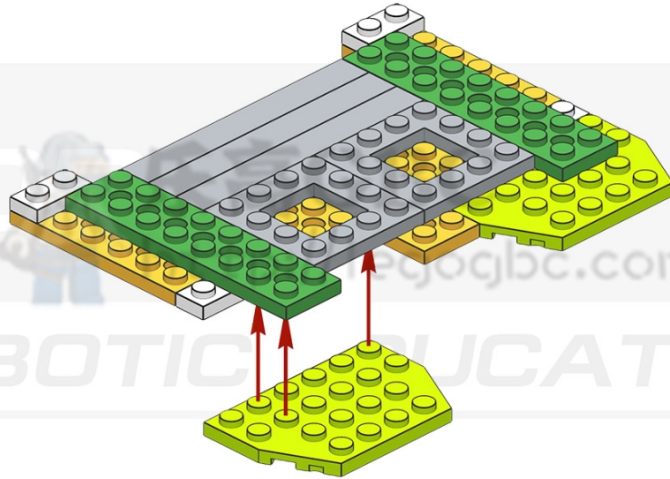

RC ROBOTICS EDUCATION

ROBOTIC EDUCATION

ROBOTIC EDUCATION

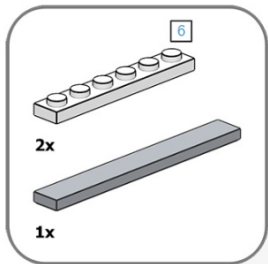

39

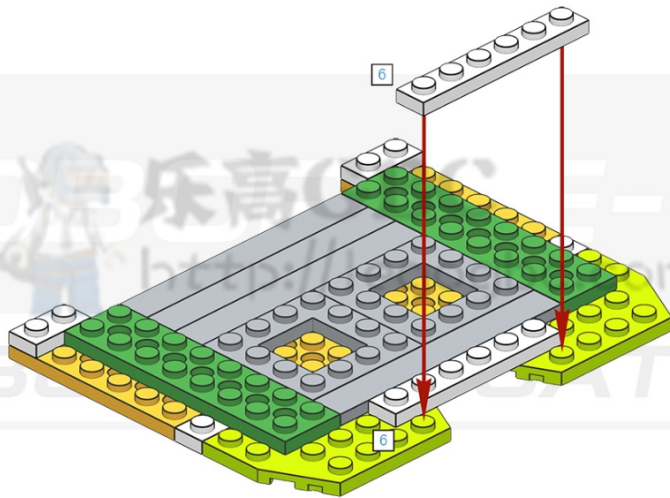

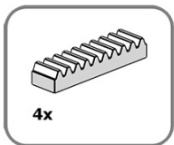

40

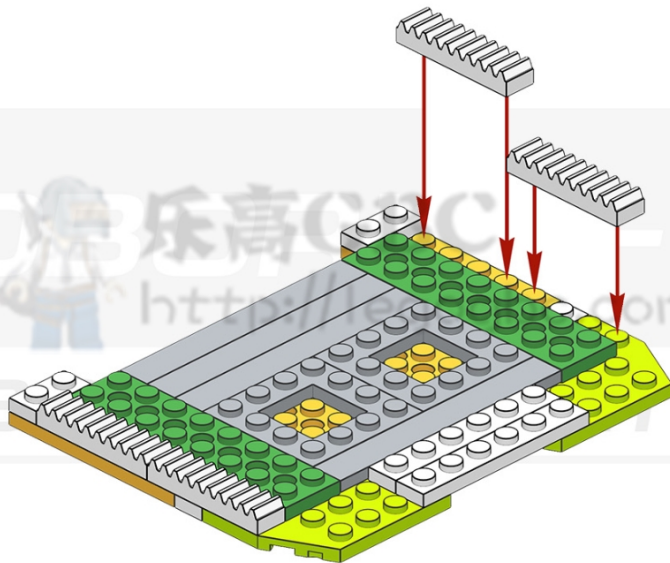



41

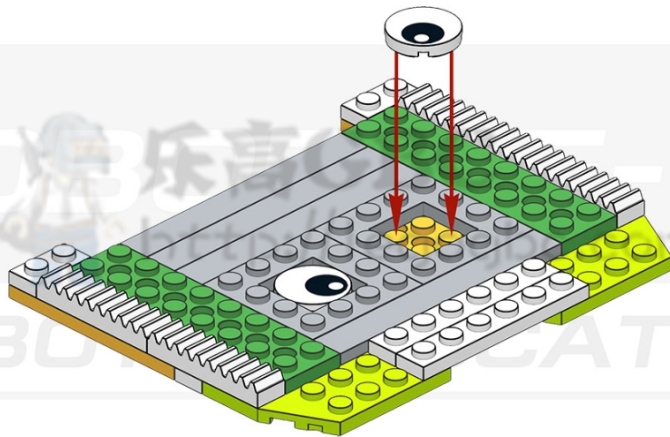

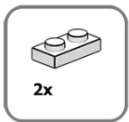

42

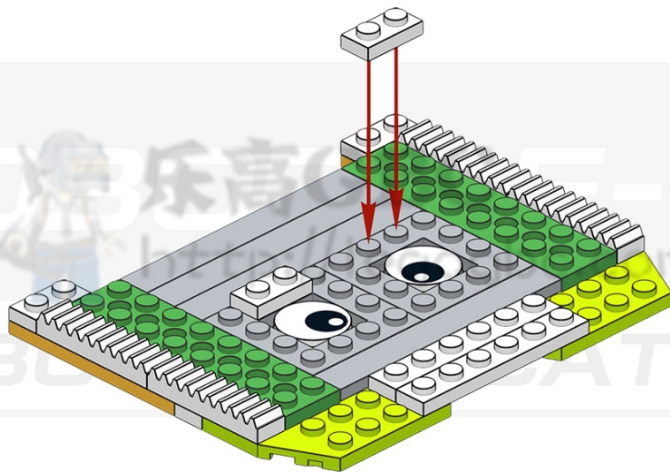

ROBO乐高 ROBO-IT!
ROBO-IT! ROBO-IT!
ROBO-IT! ROBO-IT!
ROBO-IT! ROBO-IT!

43

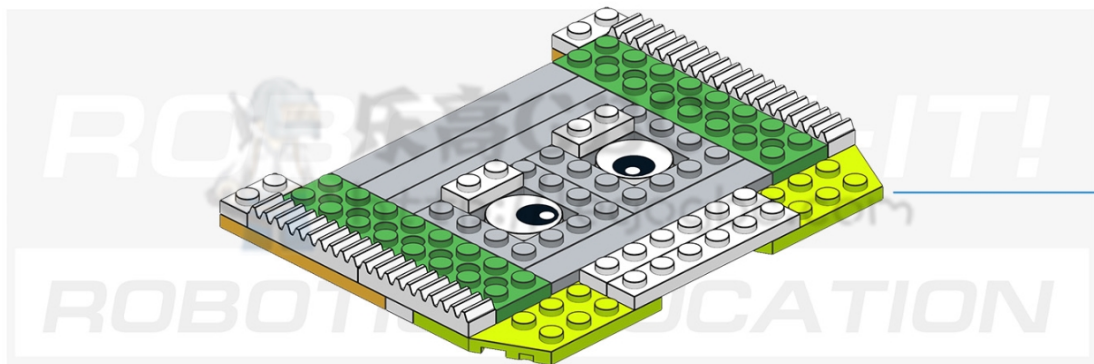

44

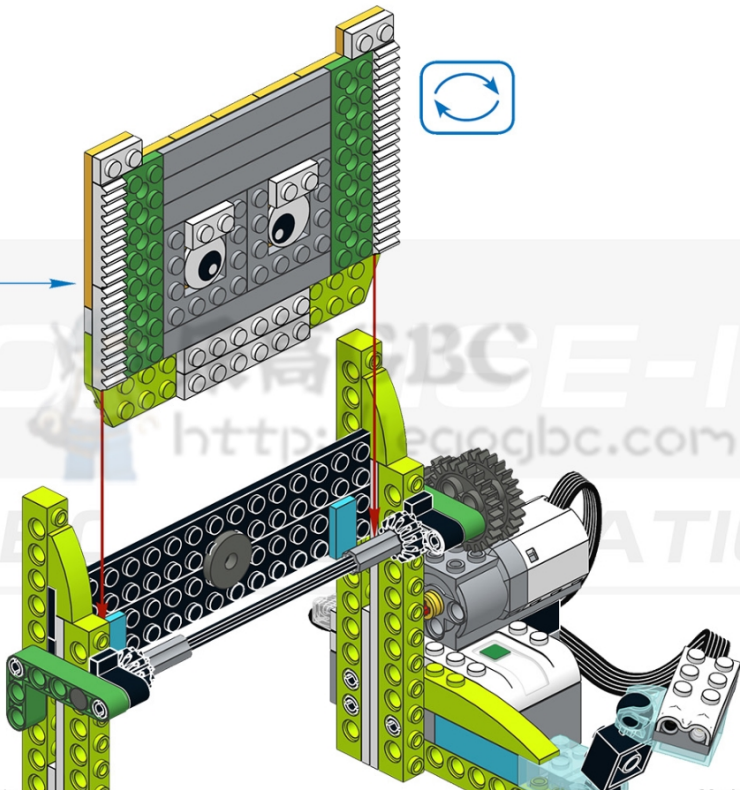

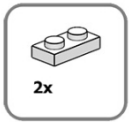

45

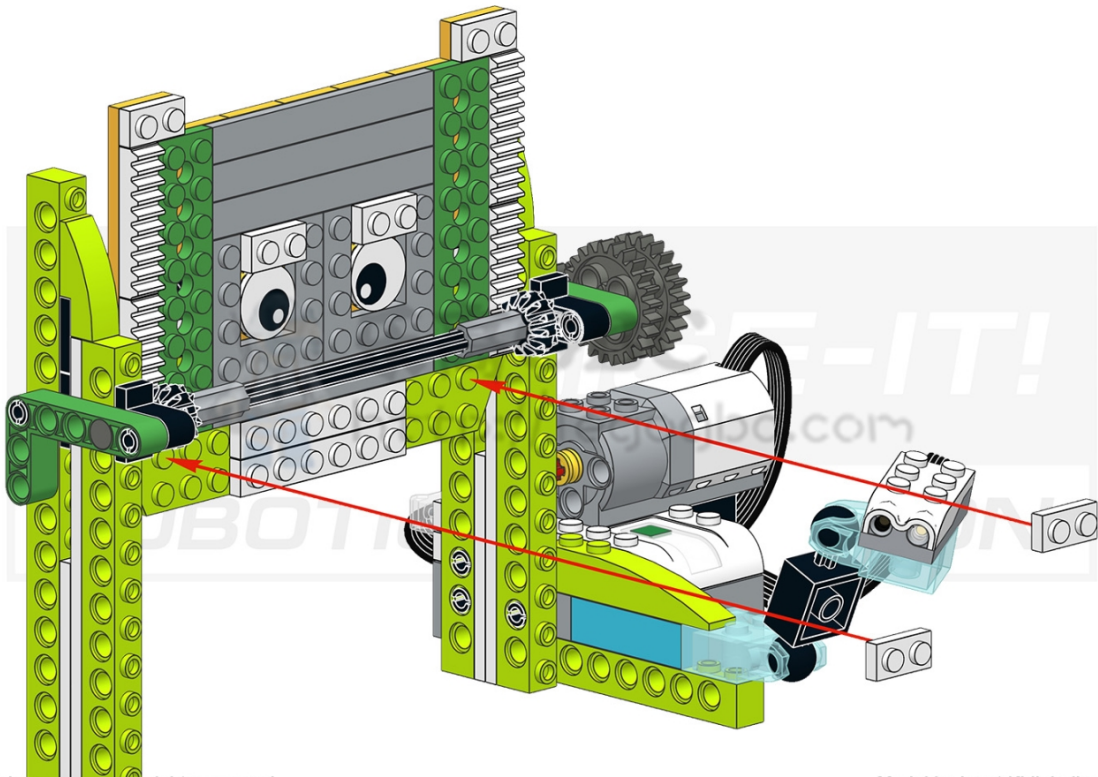

46

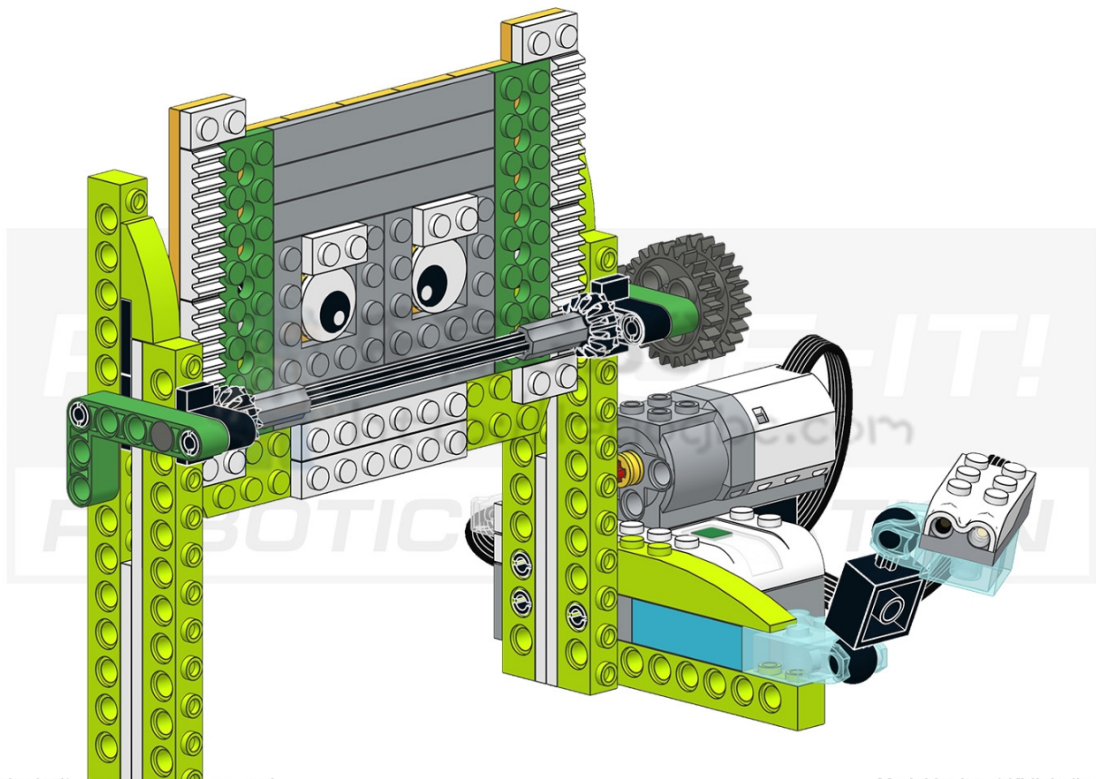



Car *



Finish the car used by the owner of the residence



Go to the first slide of
the instruction

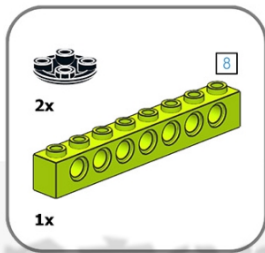
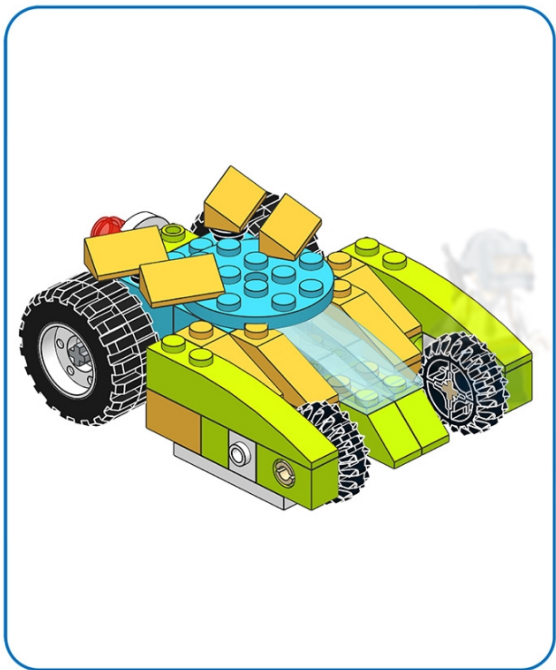

47

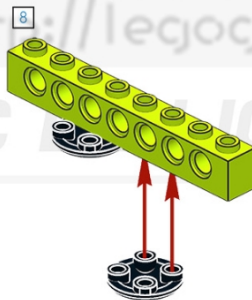

乐高GBC E-IT!
<http://legogbc.com>
TECHNIC INNOVATION

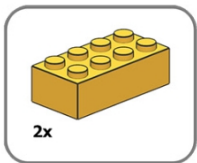

48

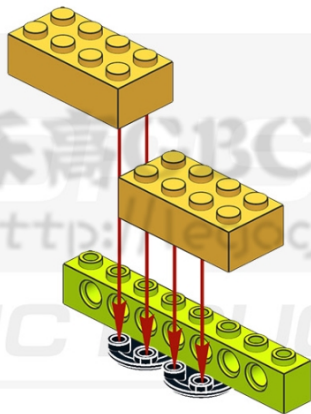

ROBO乐高BCCE-IT!

<http://legobcc.com>

ROBOTIC APPLICATION



49

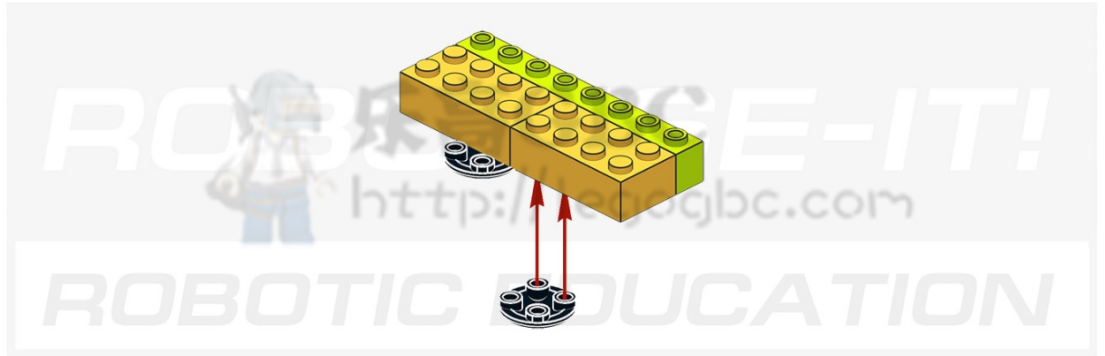

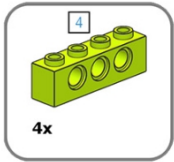

50

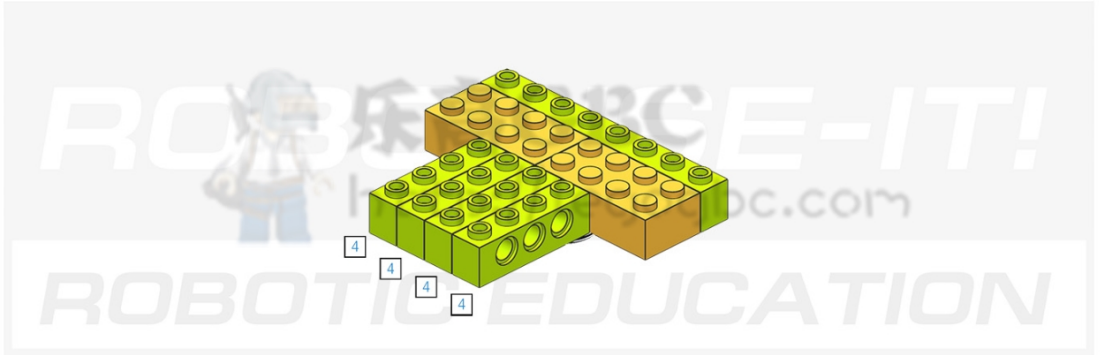

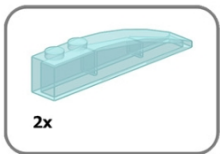

51

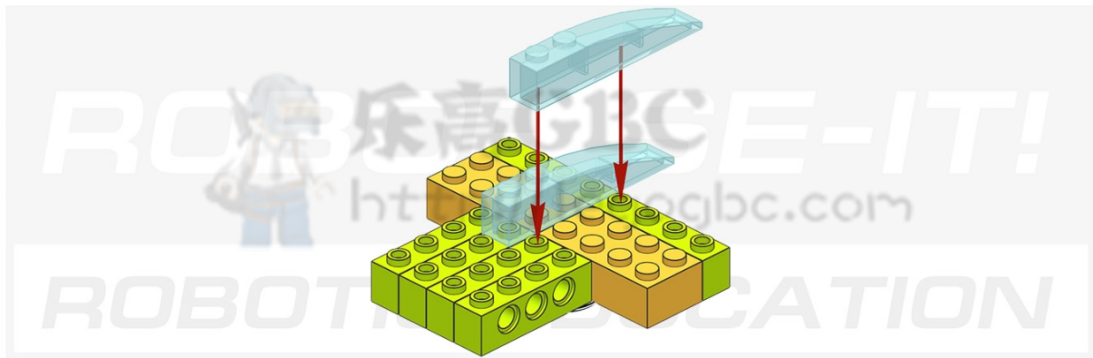

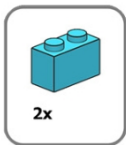

52

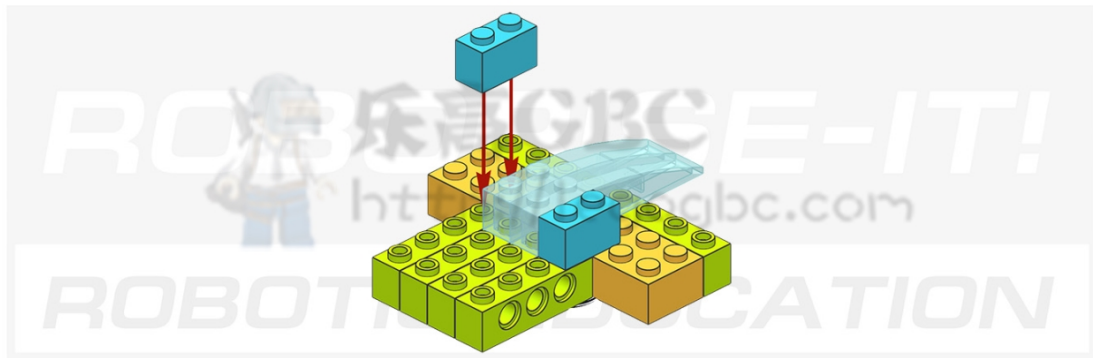



53

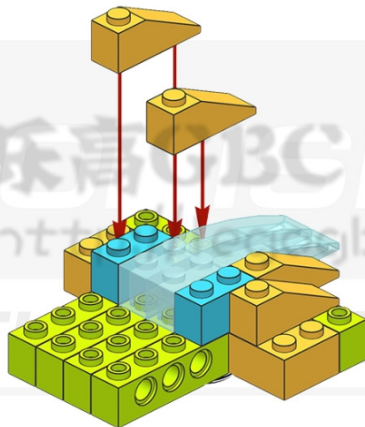

ROBOTSBC E-IT!

<http://www.robotsbc.com>

ROBOTICS EDUCATION

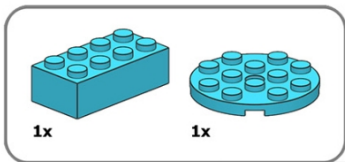

54

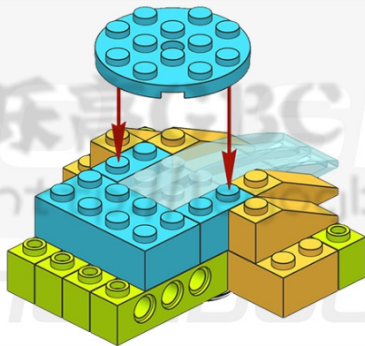

ROBOTICS-IT!

http://www.robotics-education.com

ROBOTIC EDUCATION



55

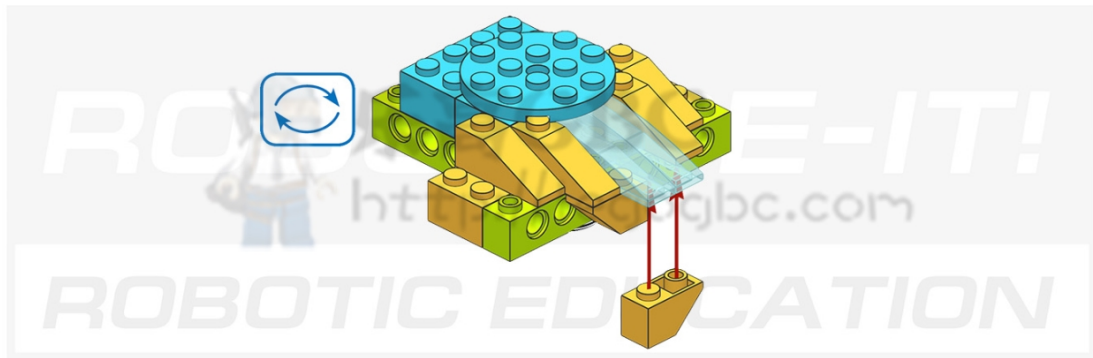



56

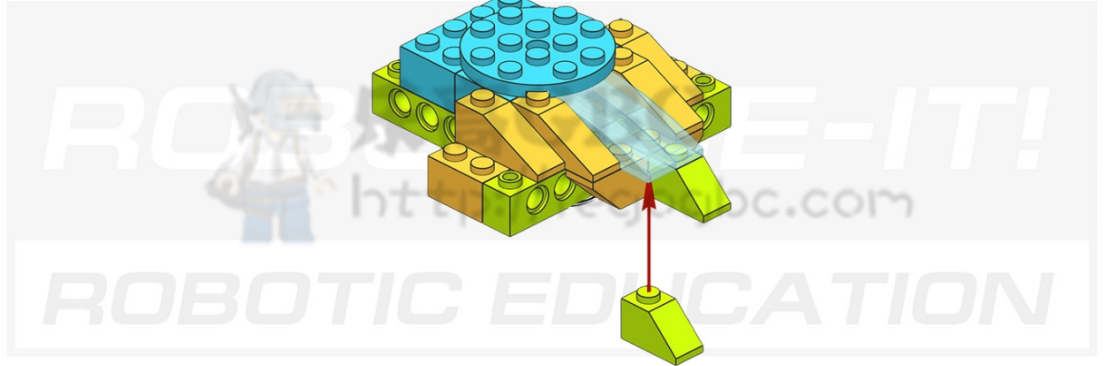



57

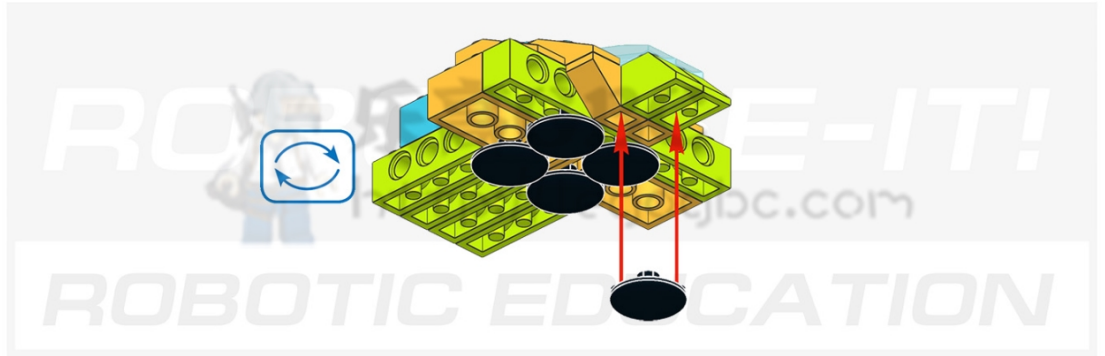

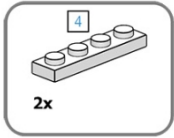

58

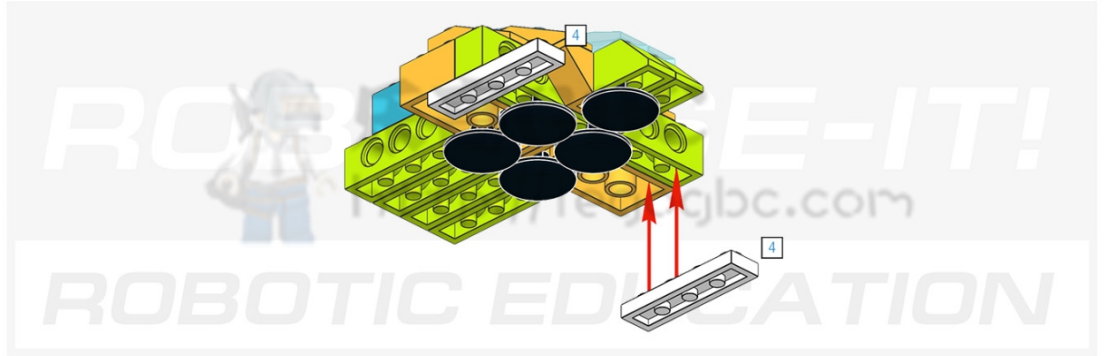

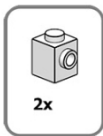

59

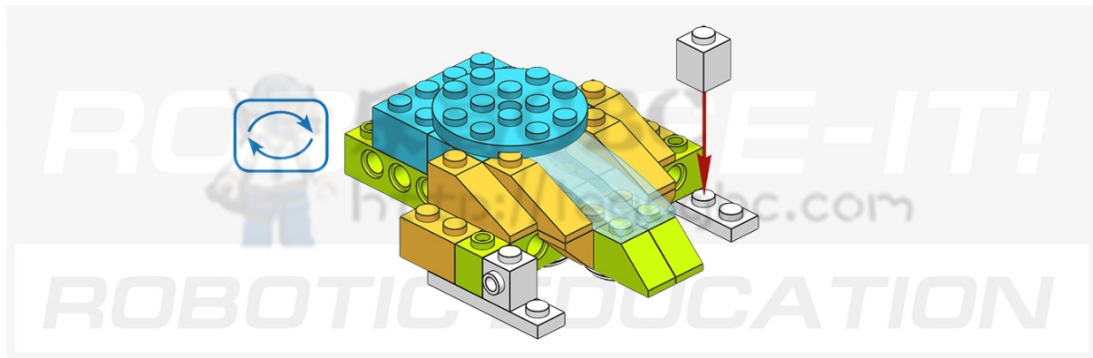



1x



1x



1x

1

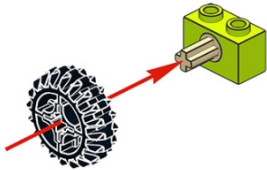

2



2x

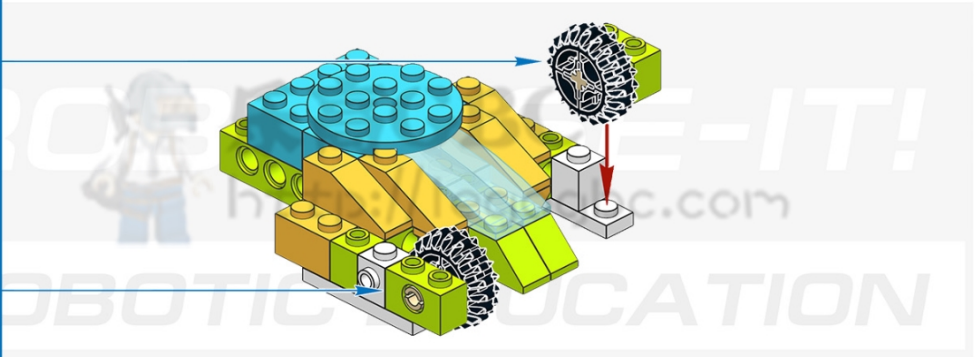
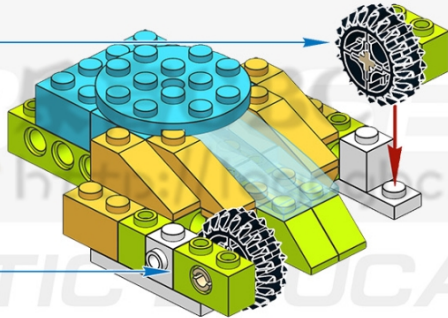

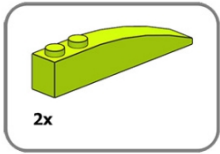

61

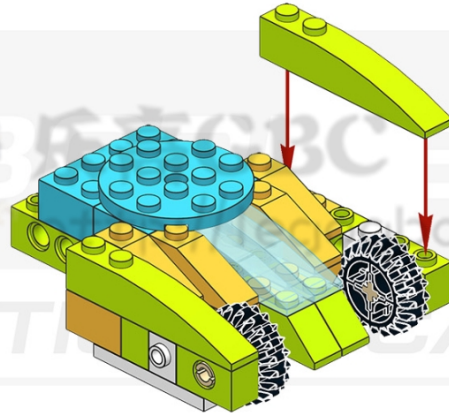

ROBOTICS

robotics.com

ROBOTICS EDUCATION

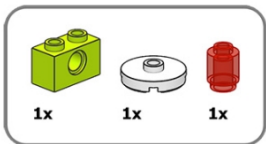

62

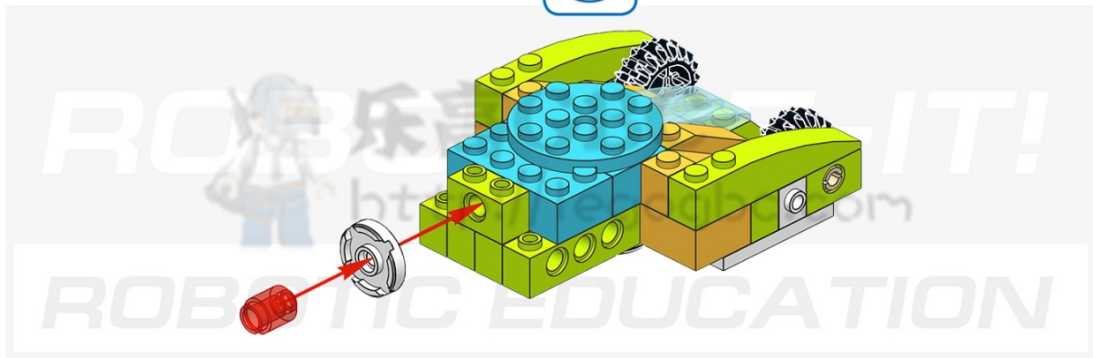

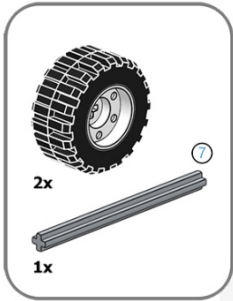

63

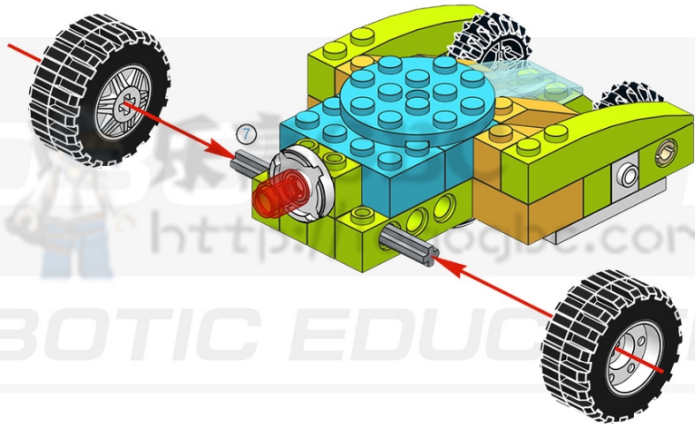

ROBOTIC EDUCATION

ROBOTIC EDUCATION!

<http://www.robotic.com>

ROBOTIC EDUCATION

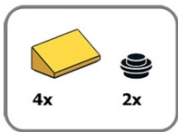

64

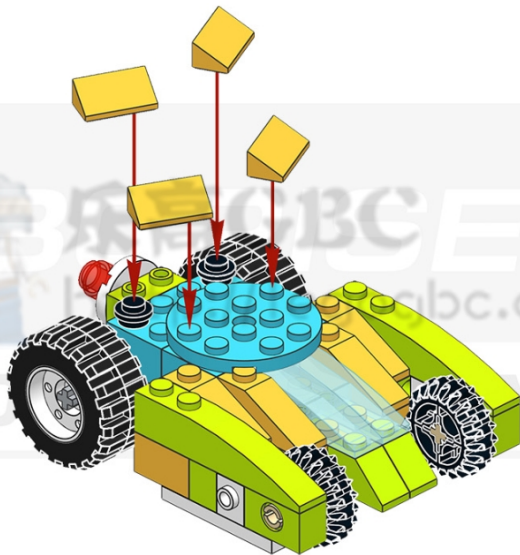

ROBOTECH-IT!

robotech.com

ROBOTICS IN EDUCATION

65

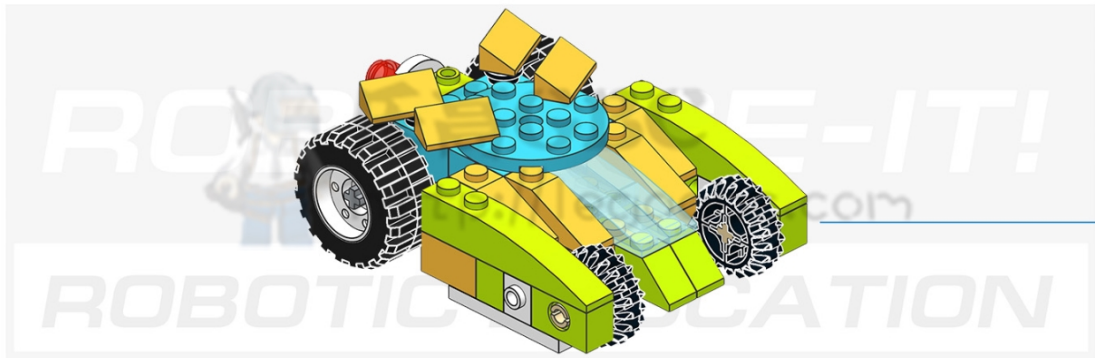

66

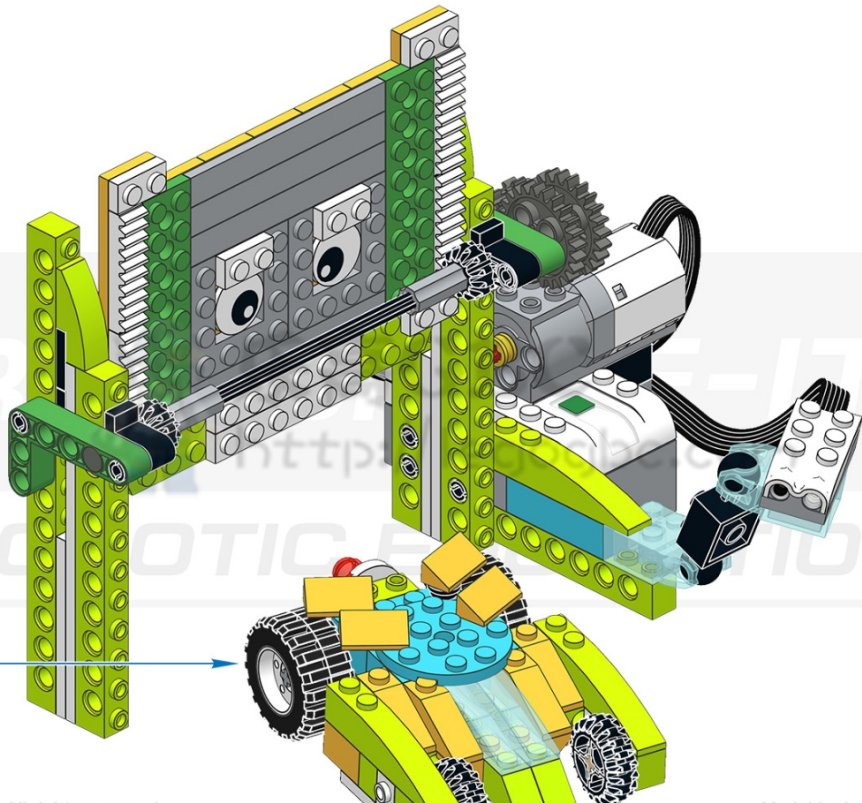

67

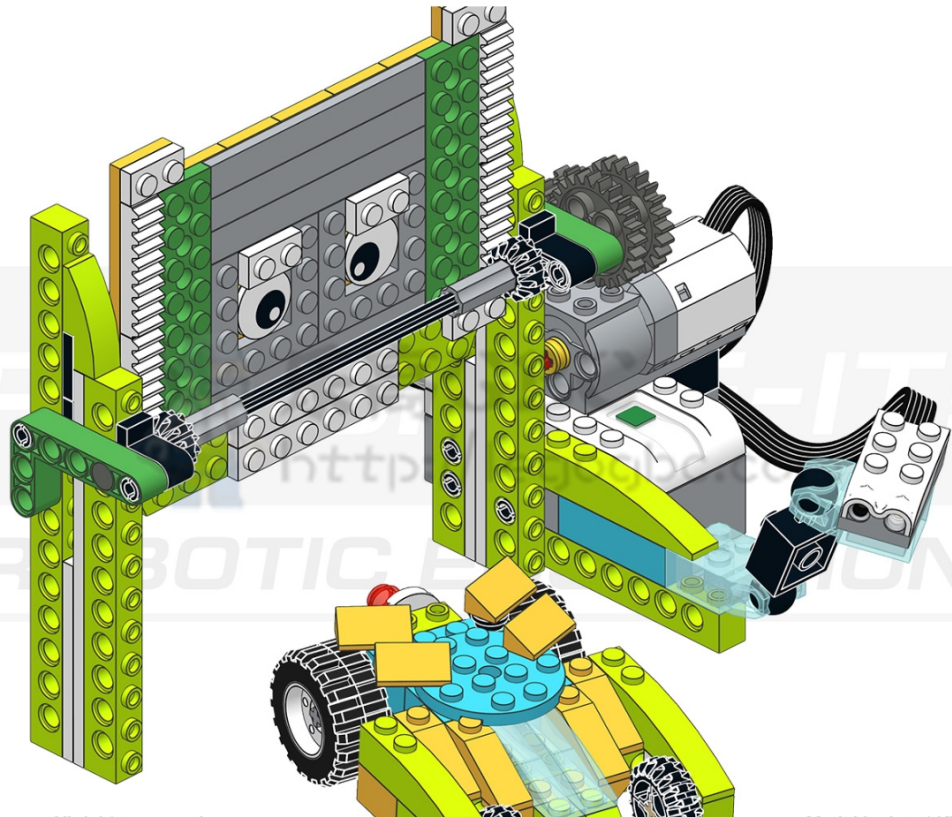



Note!



The cables must not rub while the robot is moving!



乐高GBC
<http://www.lego.com>



Tasks

Place the robot parts in the correct places



乐高GBC
<http://legogbc.com>





Task 1



Check the transmission of the robot. How does the lifting and lowering of the gate work now? How can a motor drive be built?





Discuss!



**How can a transmission be repaired?
What details are needed for this?**



Task 2



One possible solution is to use a belt drive. Install the driven pulley and belt.





Task 3



Program the gate controls using the buttons as on the remote control





Task 3. Program



Scratch



WeDo Software



Program the robot controls using the buttons.

In the Scratch 3.0 programming environment, the program looks like this:

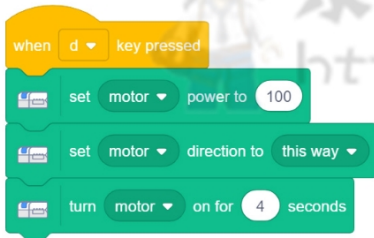

Adjust the duration of the movement so that the cogging of the toothed racks does not occur.

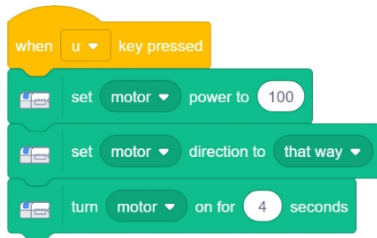



Task 3. Program



Scratch



WeDo Software



Program the robot controls using the buttons.

In WeDo Software, a similar program looks like this:





Task 4 *



The gate is equipped with a motion sensor. Use it to automatically open and close the gate.





Task 4 *. Program



Scratch



WeDo Software



Program automatic gate operation

In the Scratch 3.0 programming environment, the program looks like this:

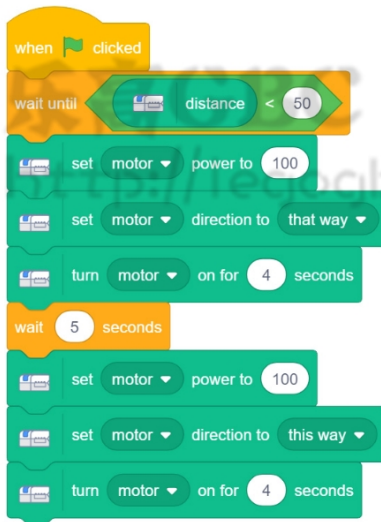



Task 4 *. Program



Scratch



WeDo Software



Program automatic gate operation

In WeDo Software, a similar program looks like this:

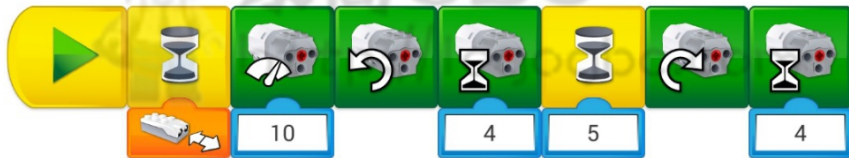



Task 4 *



The detection point of the car will depend on the position of the motion sensor. To adjust the trigger point of the motion sensor, use the hinges on which it is attached.





Question



How should the motion sensor be placed so that it can detect the approach of the car to the gate?

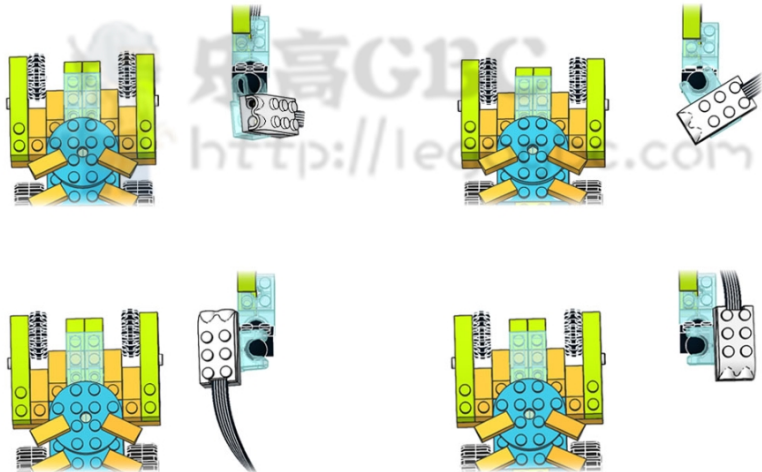



Tasks



At what direction of rotation of the gears will the gate rise?



Check
answer

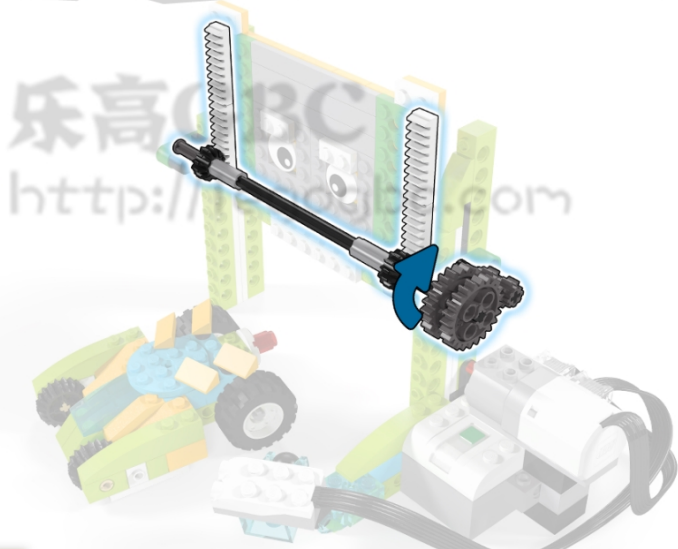



Question



Scratch



WeDo Software



Which of the waiting blocks reacts to the appearance of the car?



```
when clicked
  wait until distance < 50
  set motor power to 100
  set motor direction to that way
  turn motor on for 4 seconds
  wait 5 seconds
  set motor power to 100
  set motor direction to this way
  turn motor on for 4 seconds
```



Question



Scratch



WeDo Software



Which of the waiting blocks reacts to the appearance of the car?

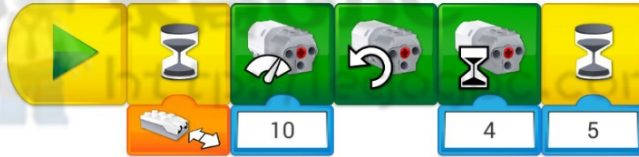



Discuss!

- ▶ What gear did you use to build the robot's transmission?
- ▶ What part prevented the gate from closing in manual mode?
- ▶ What parts have been used so that the motion sensor can be configured to work with different cars?
- ▶ How does the gate rise and fall without distortion?





Your achievements

Total:

0



1



2



3



4

