

1

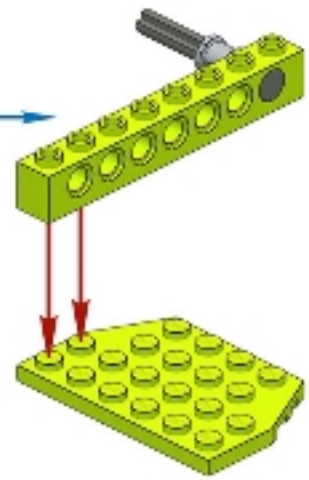

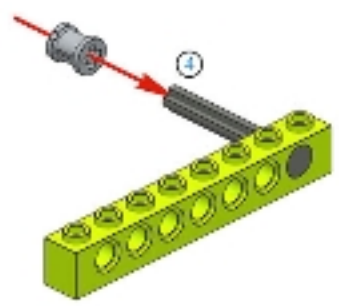

1

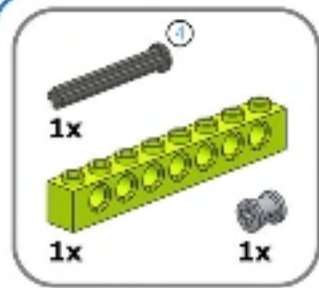
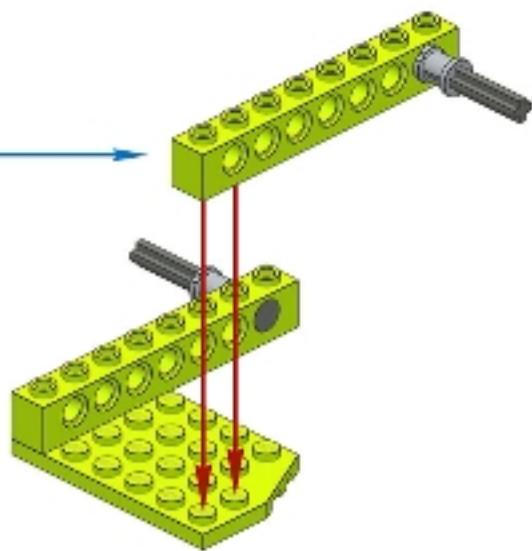
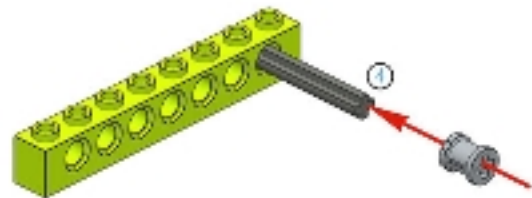

3

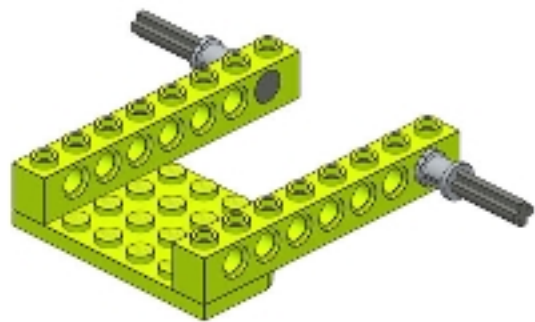

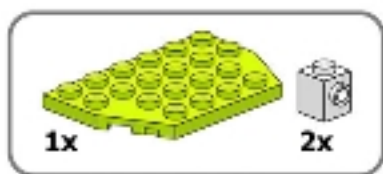

4

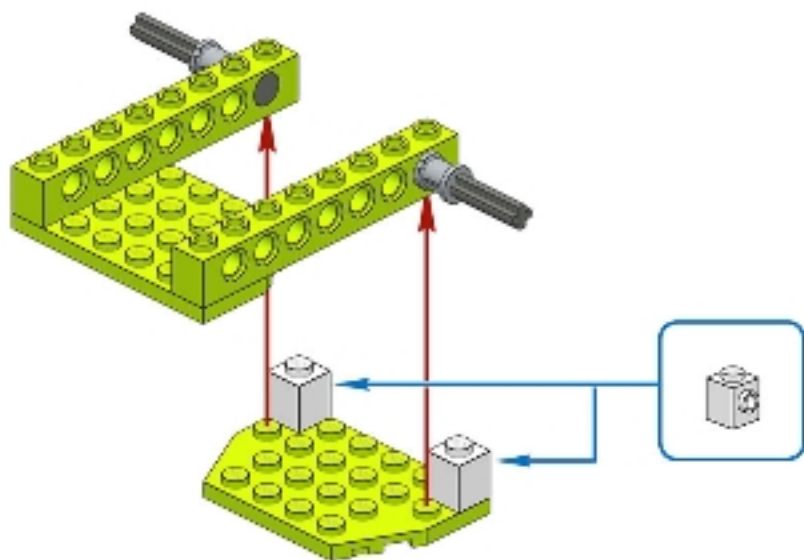

5

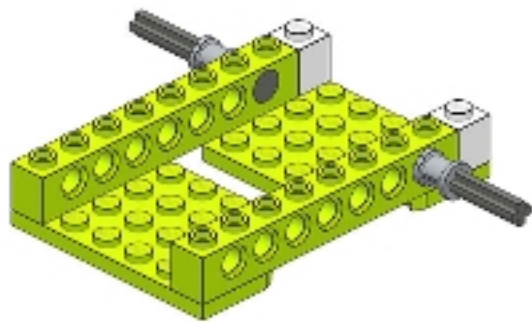



2x

6

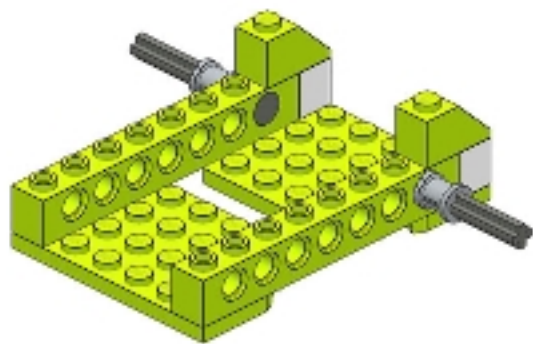

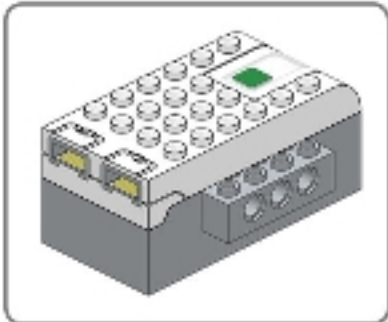

7

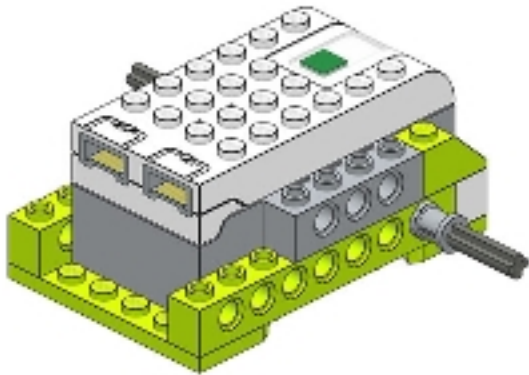

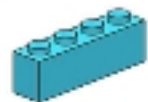

2x

8

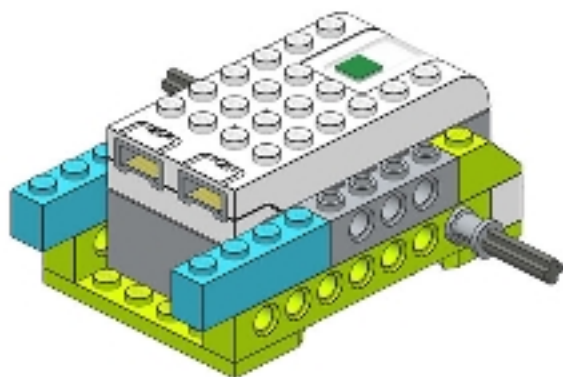

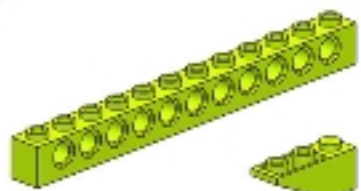

1x

1x

9

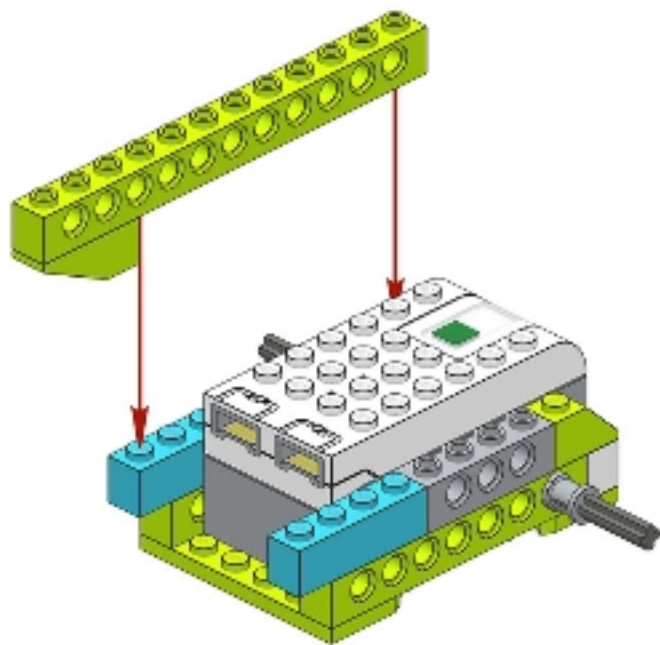

10

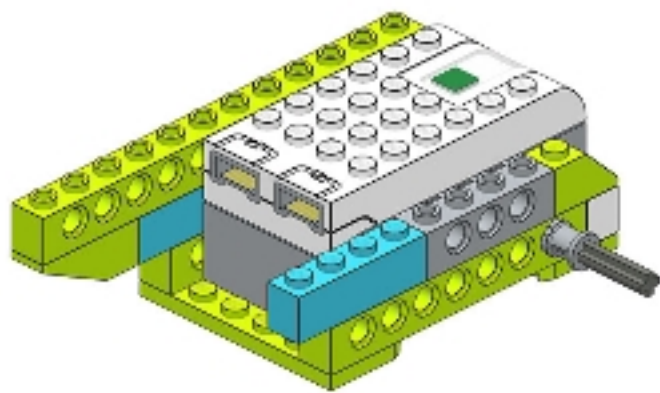



1x
1x

1

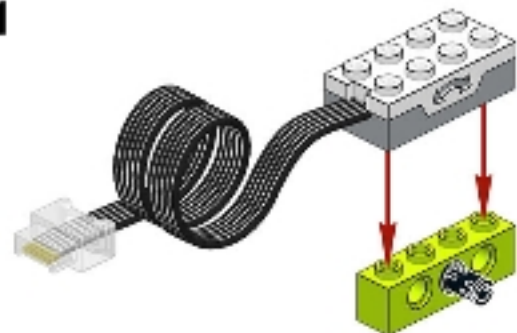

2

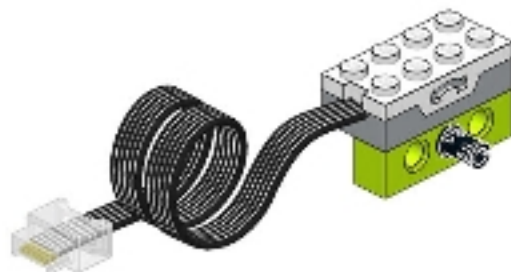

12

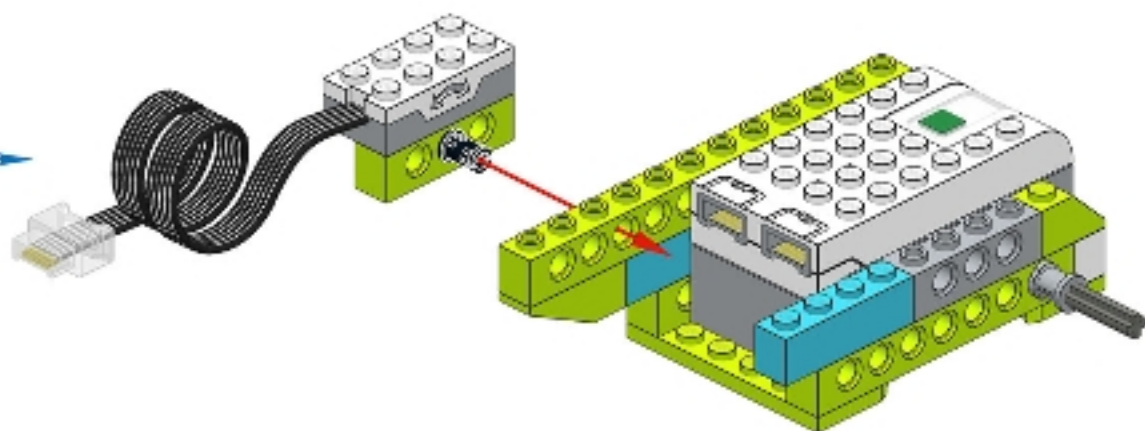

13

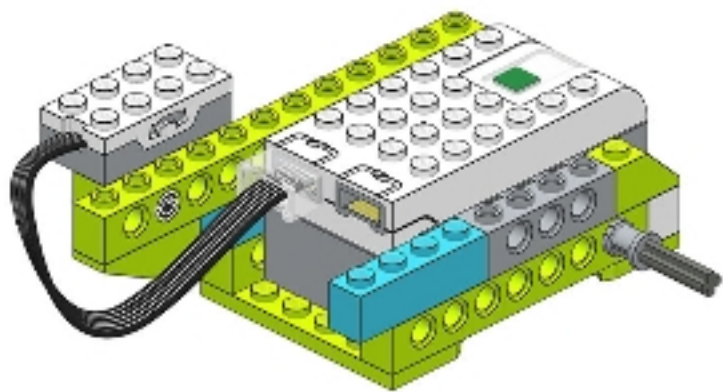

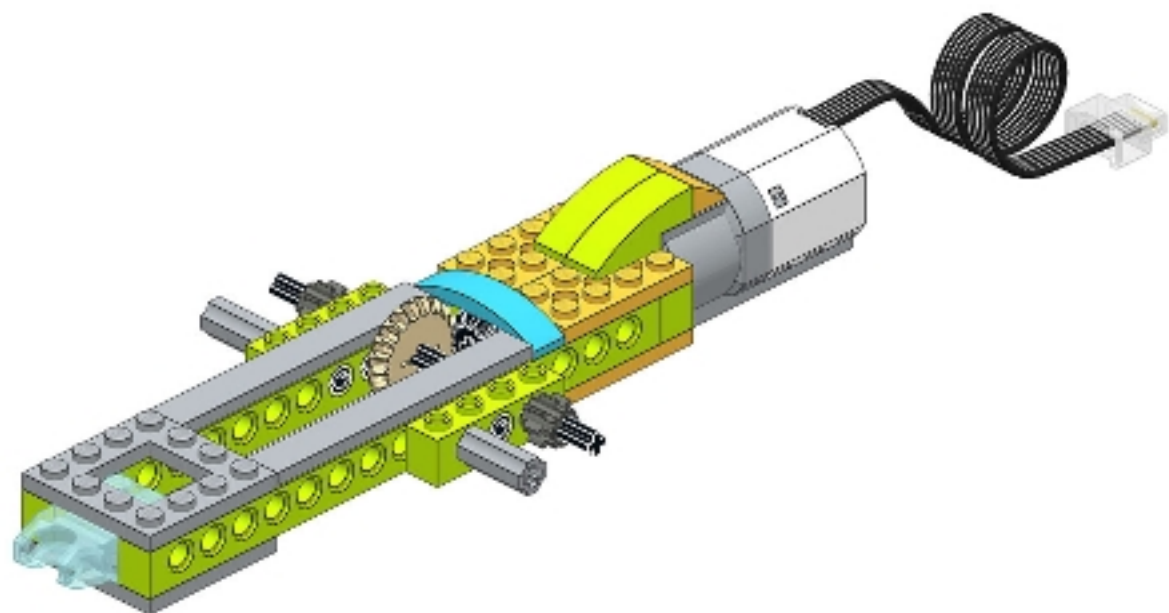



2x



1x



2x

15

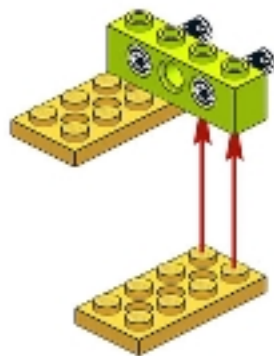



2x

16



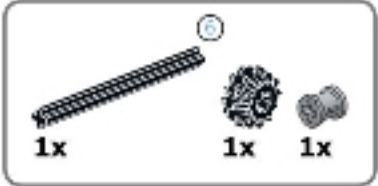

17

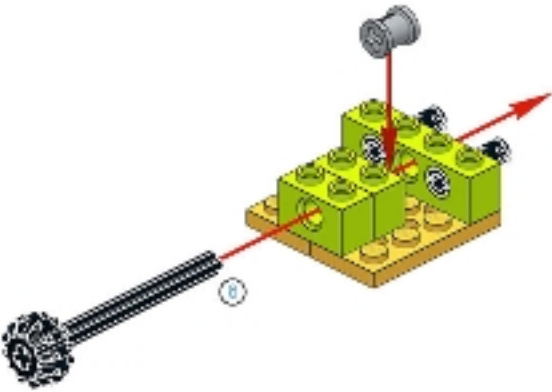

18

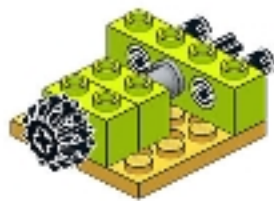

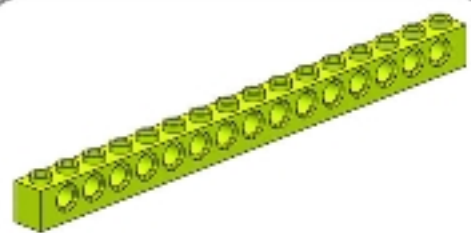

2x

19

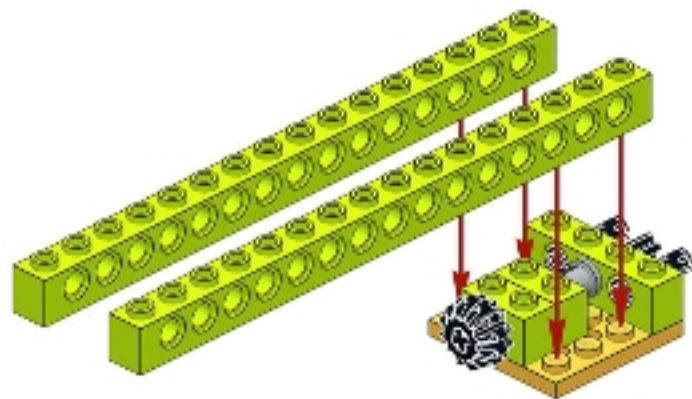

20





1x

21

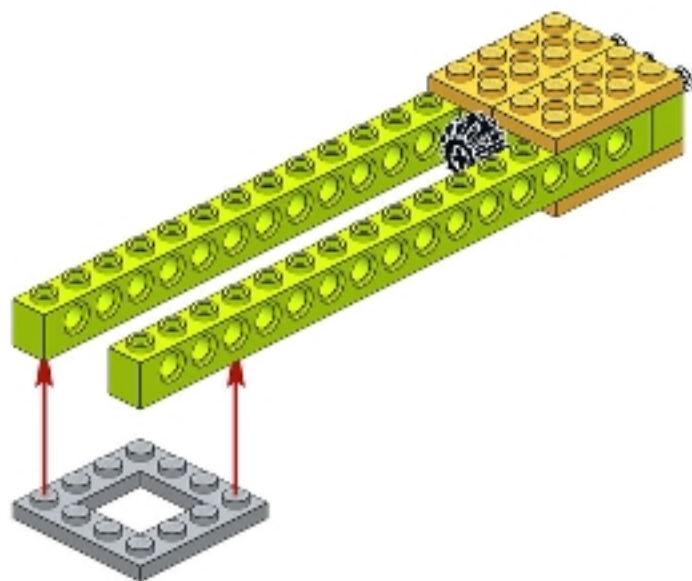

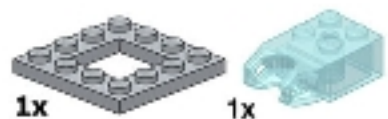

22

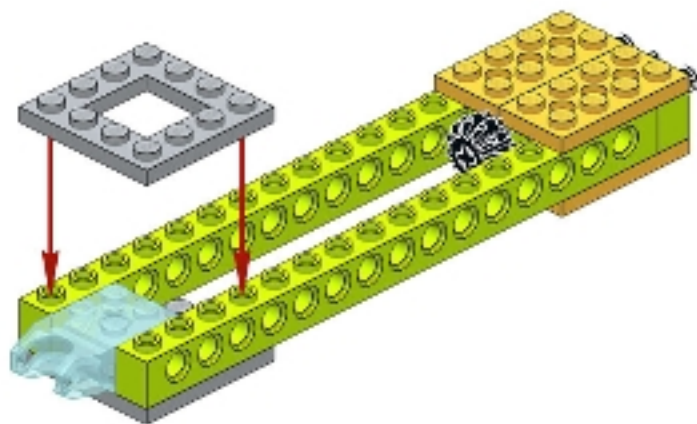

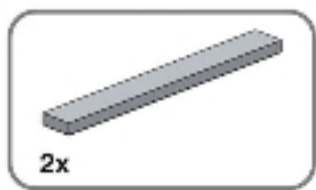

23

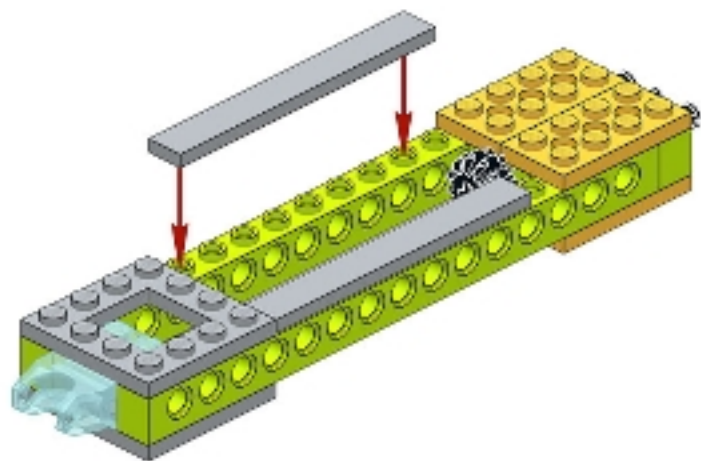

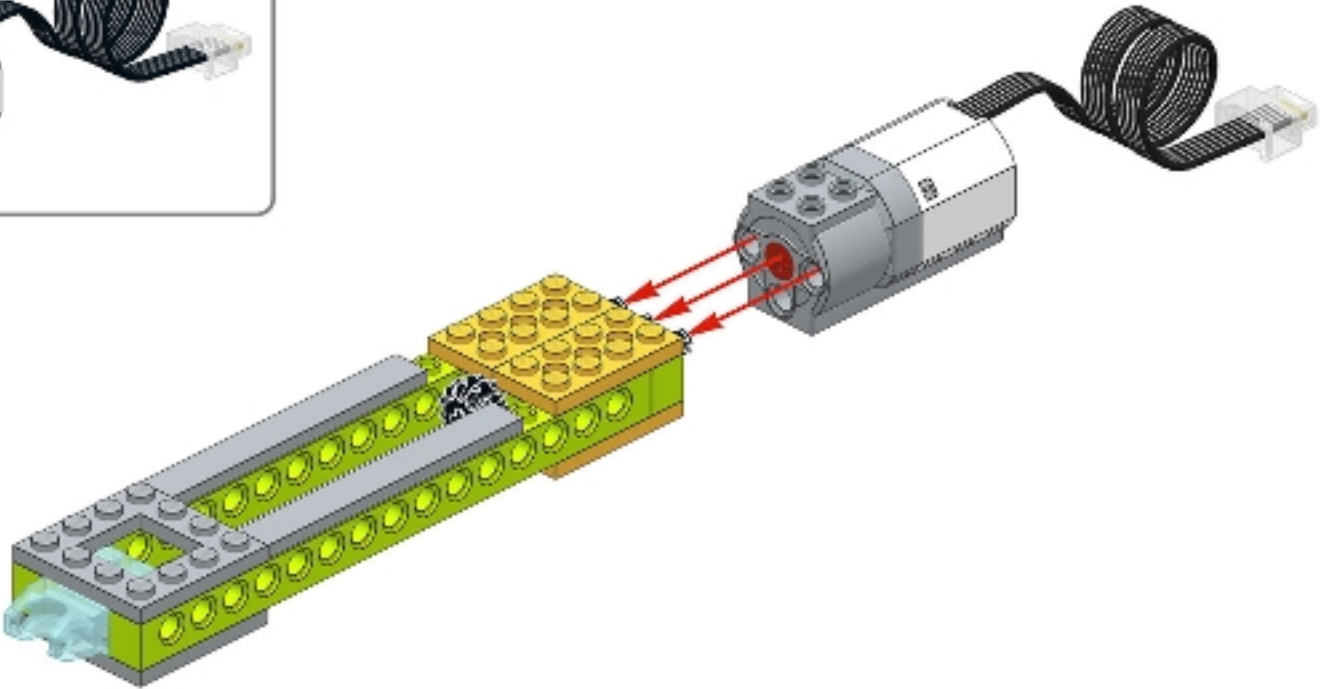
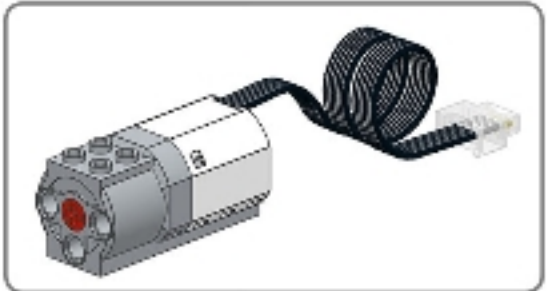

24

25

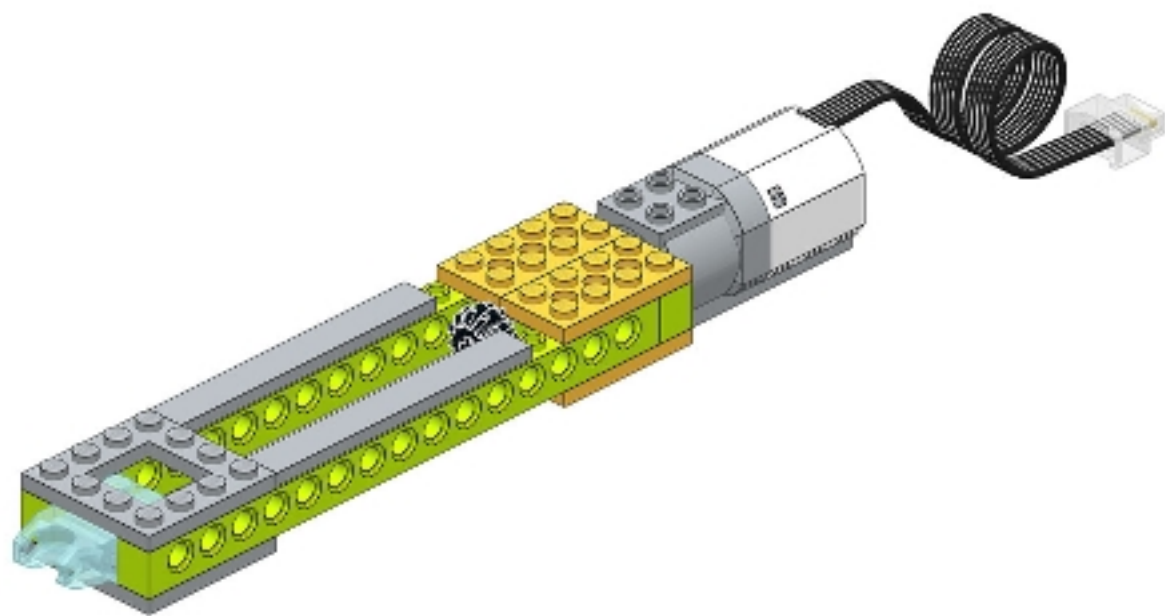



1x



26

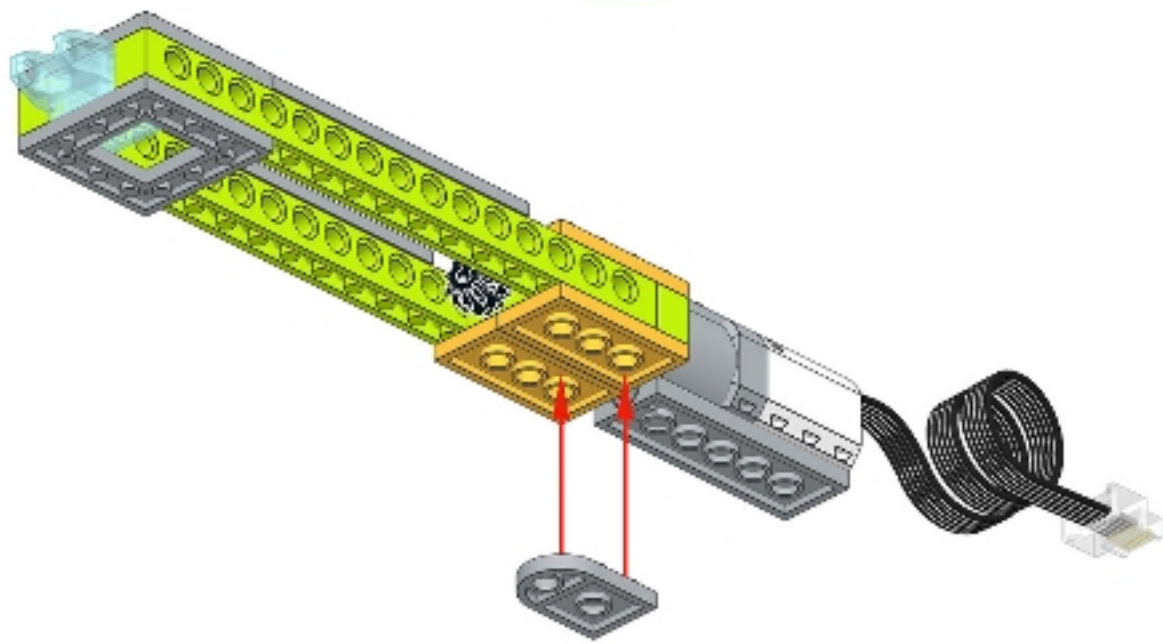



1x

27

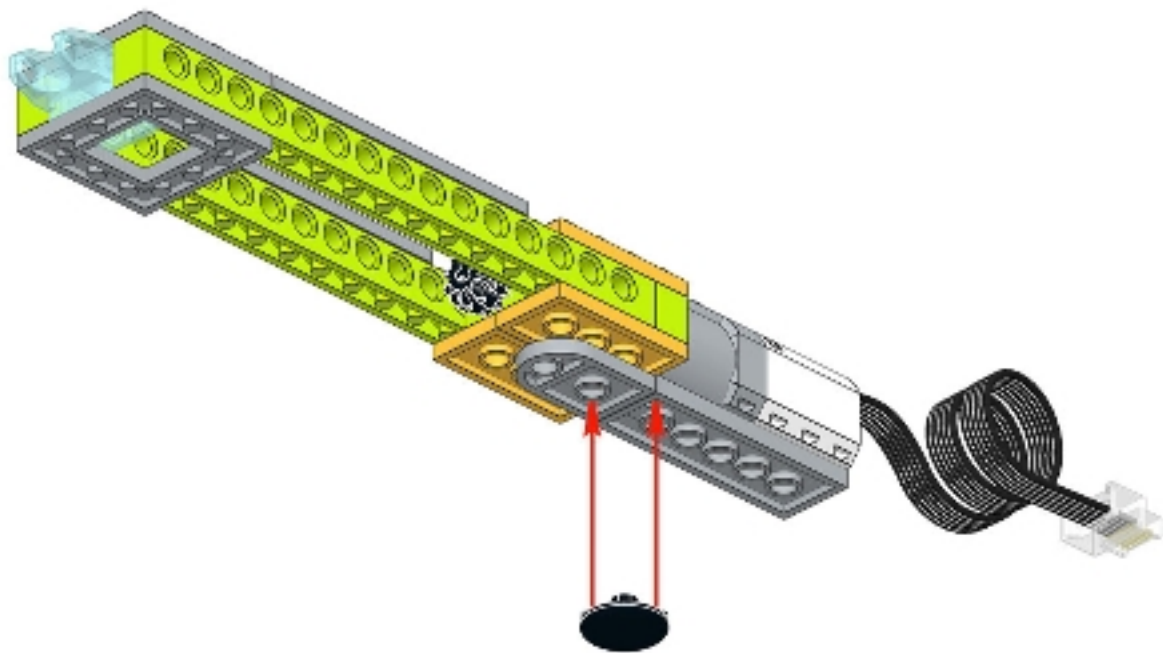



2x



29

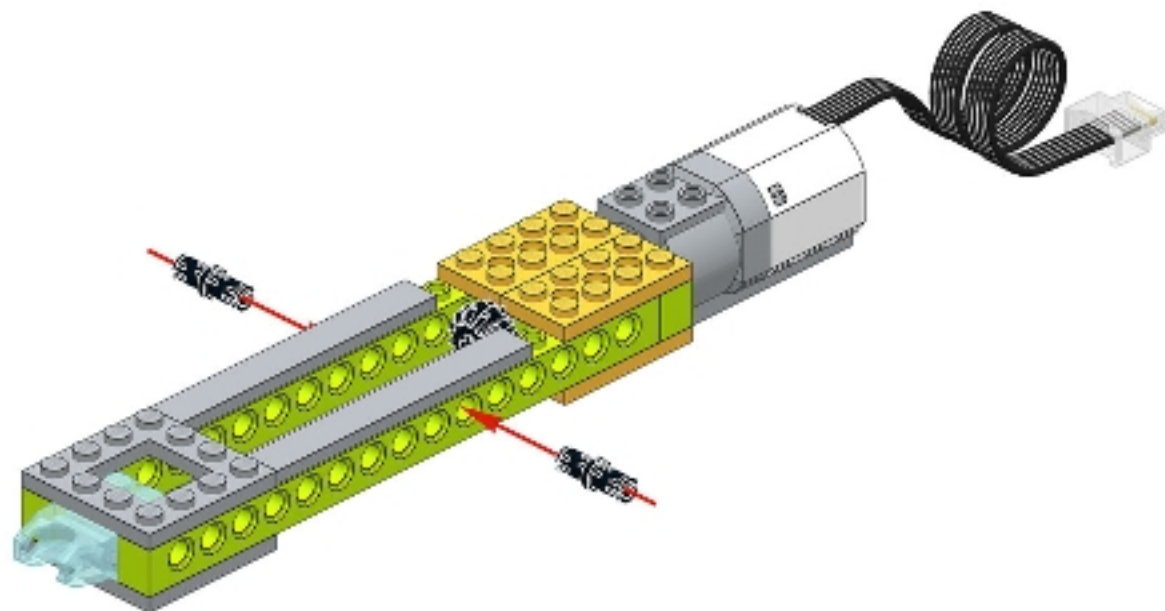



2x

30

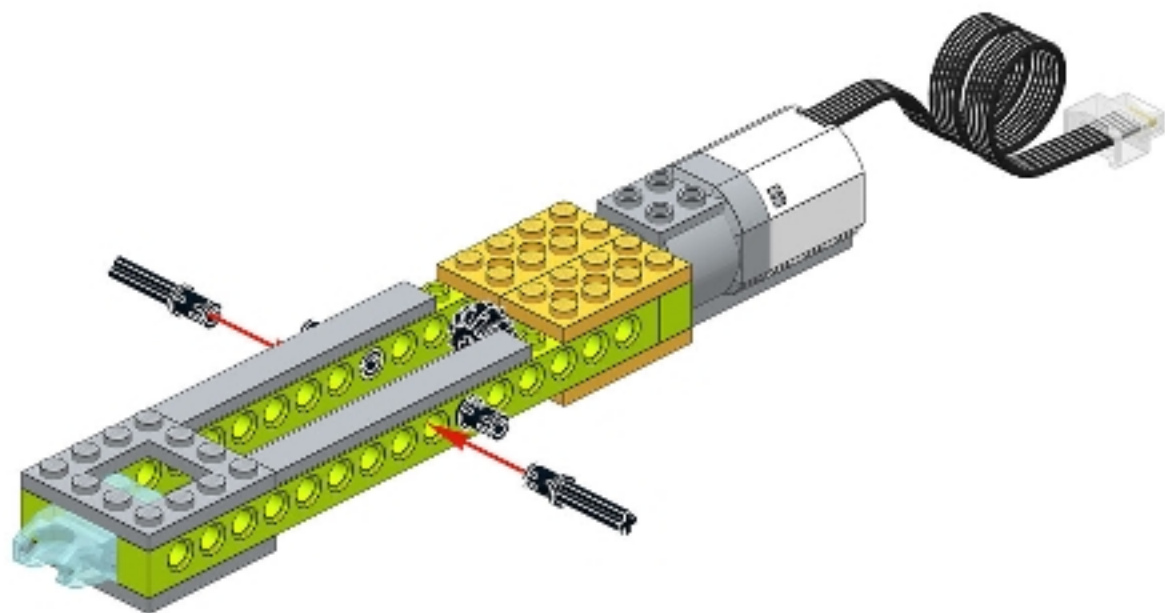



2x

31

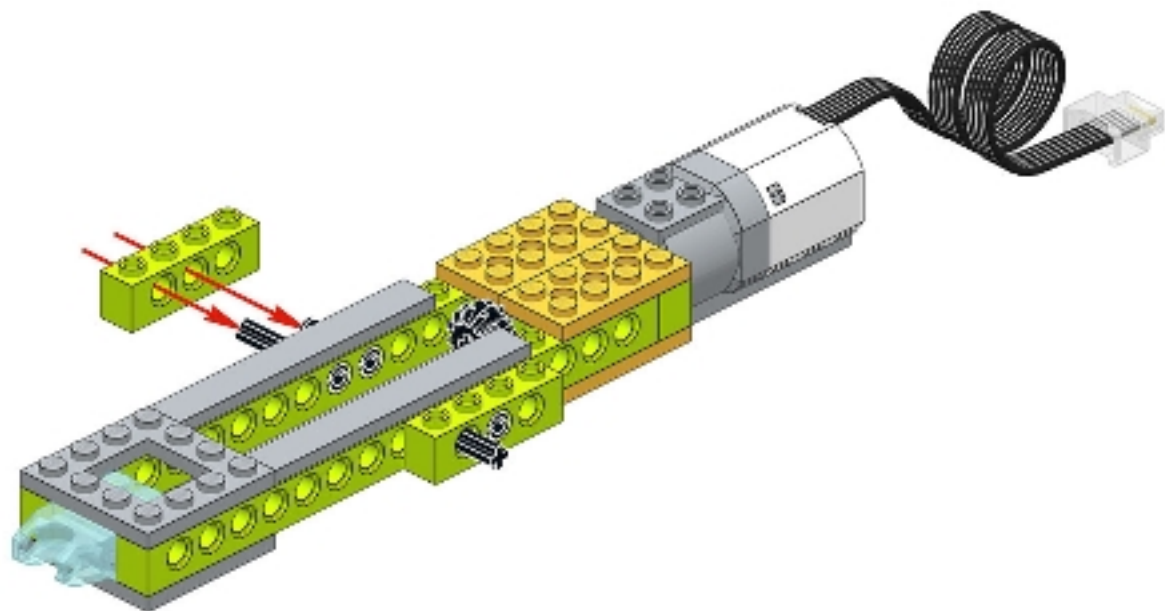

32

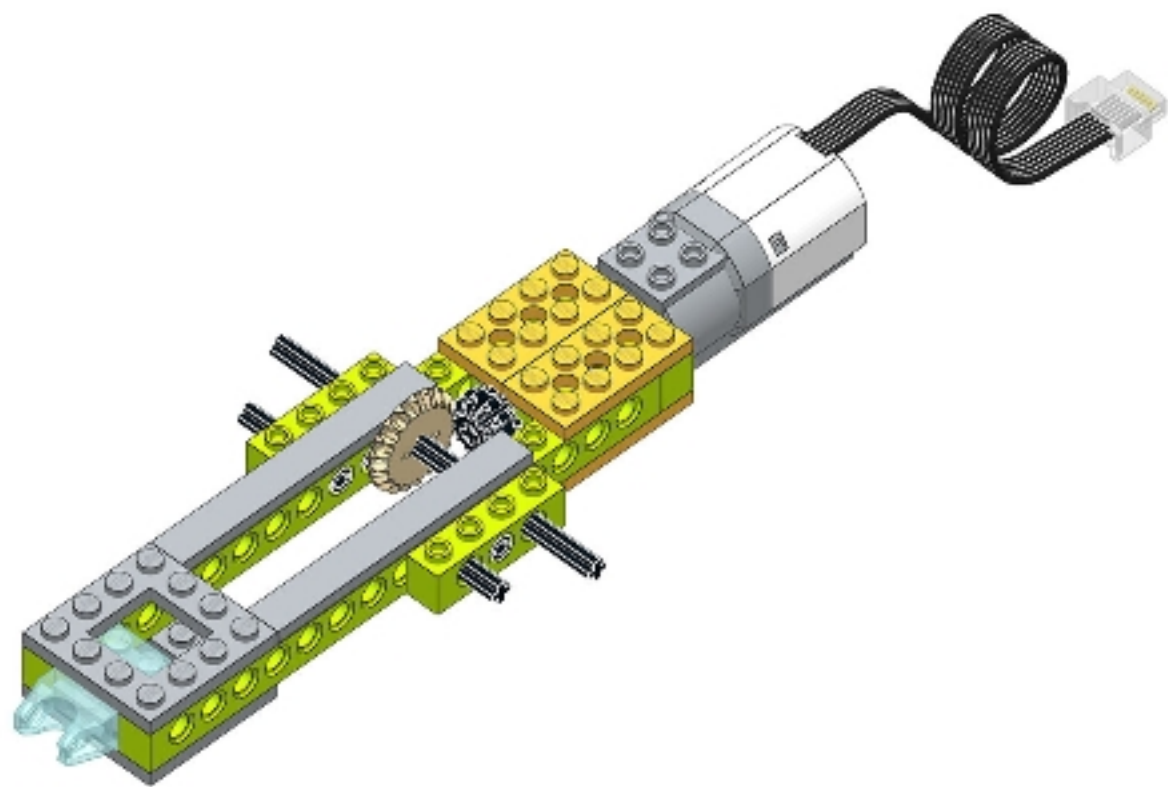

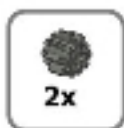

33

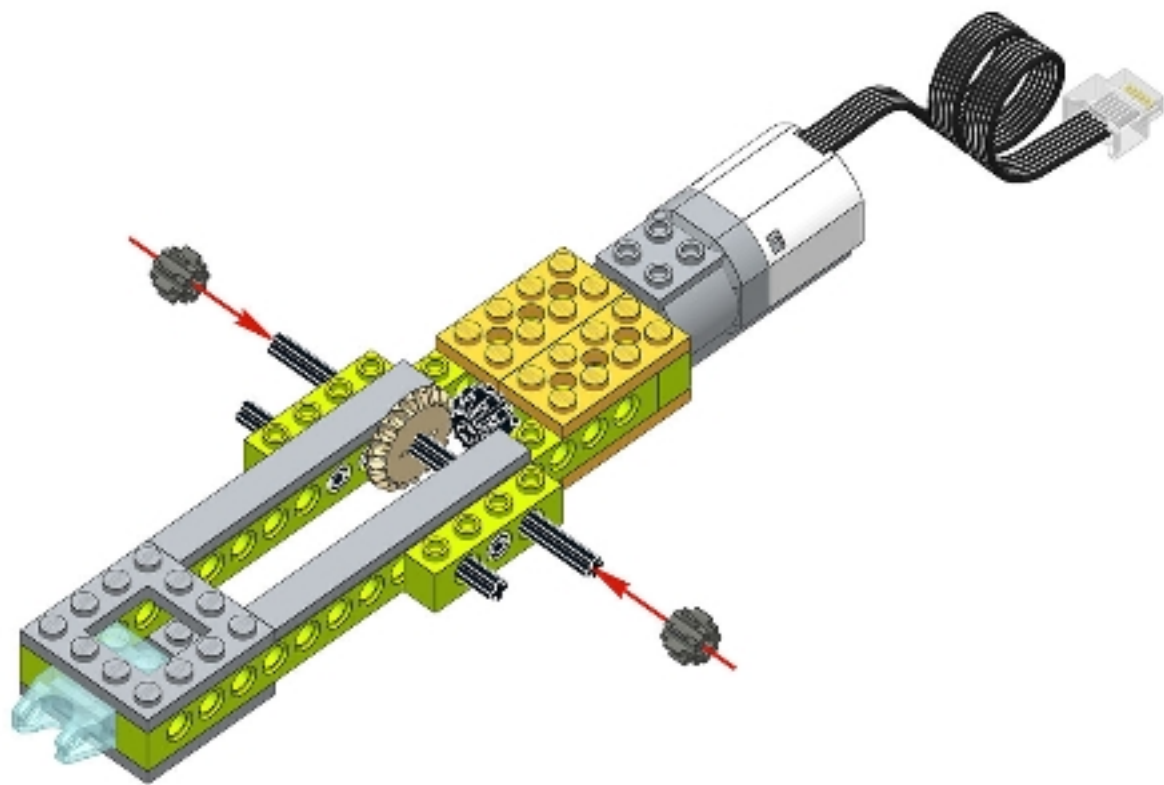



2x

34

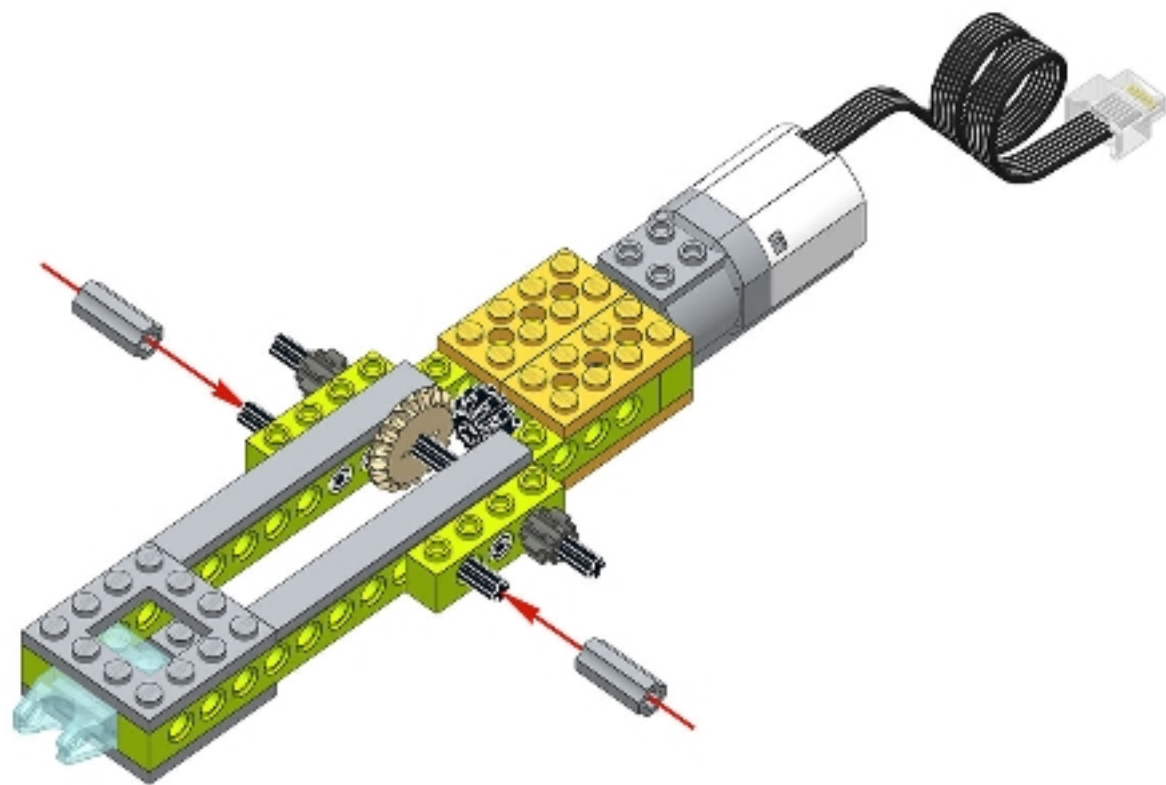



1x

36

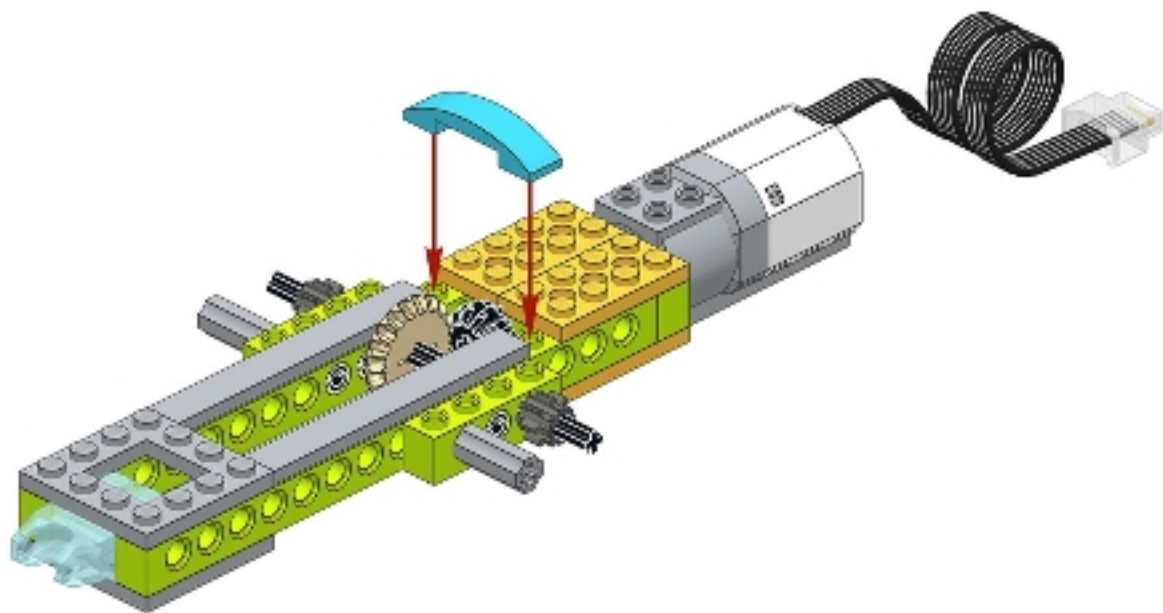

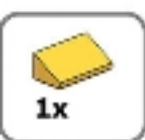

37

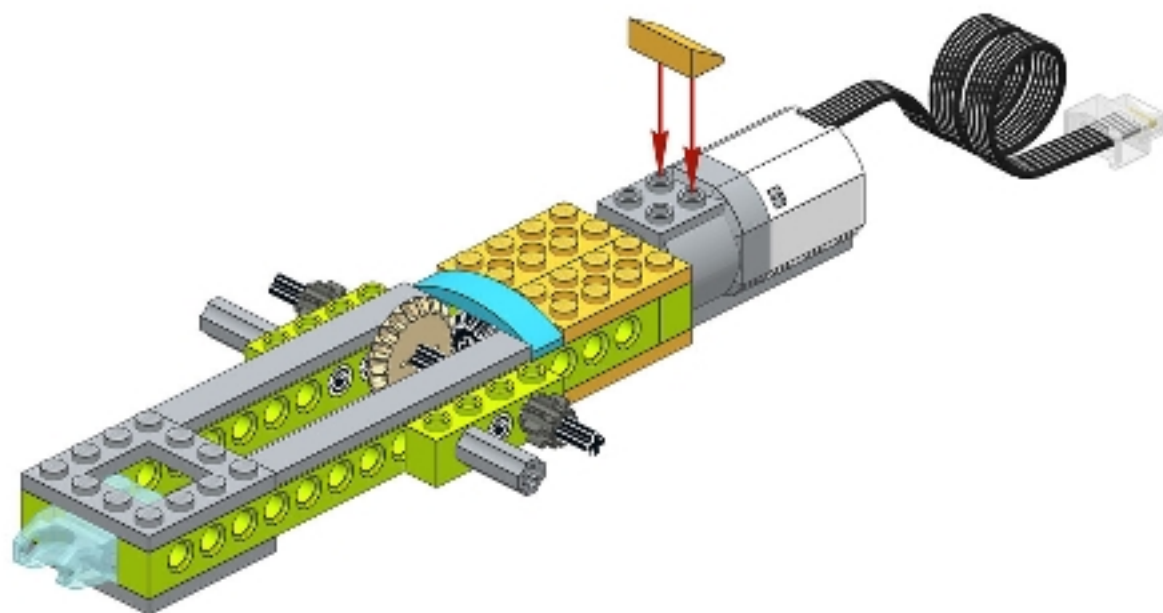

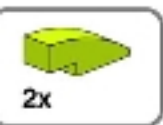

38

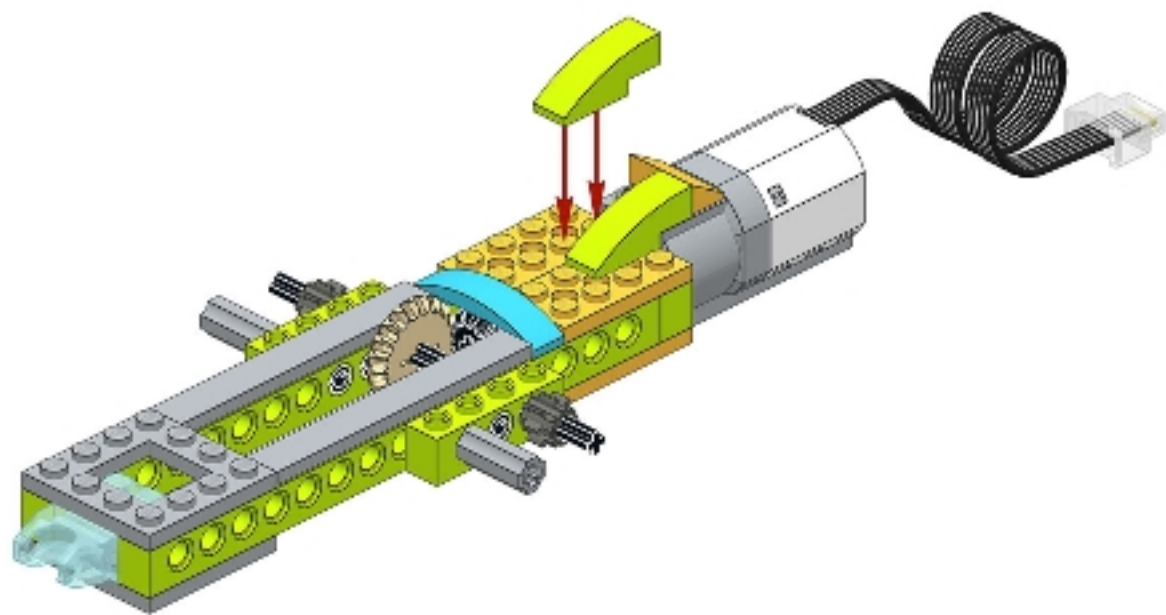

39

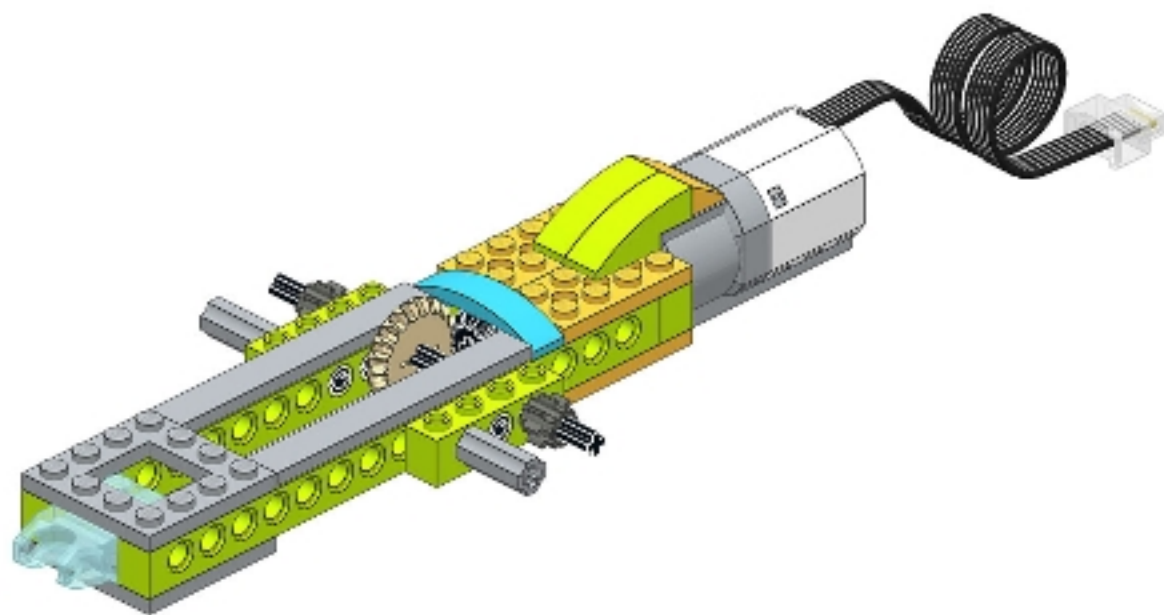



1x

1x

1

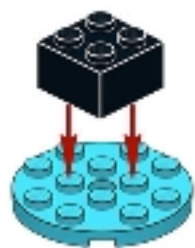

2x

2

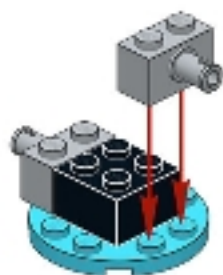

2x

3

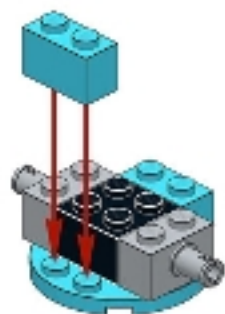



1x

4

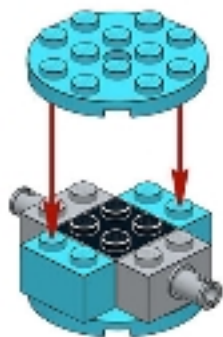

5

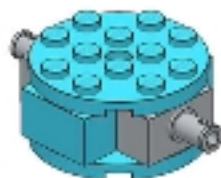

43

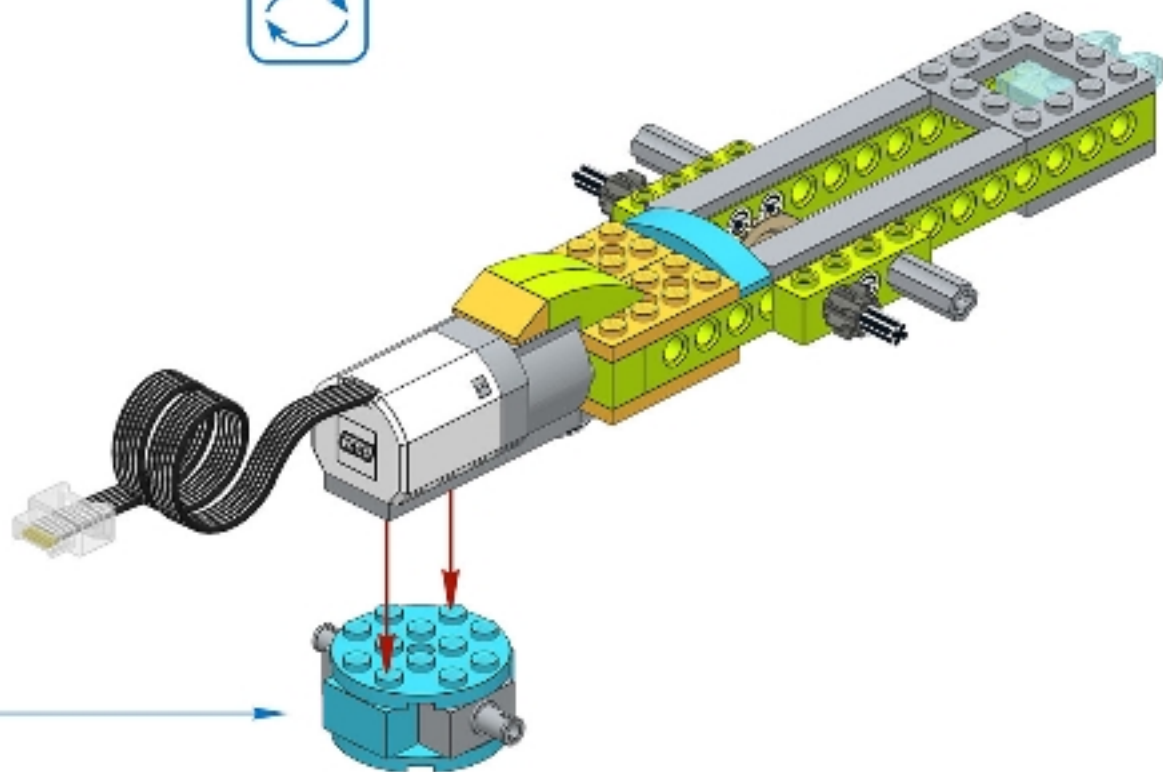

44

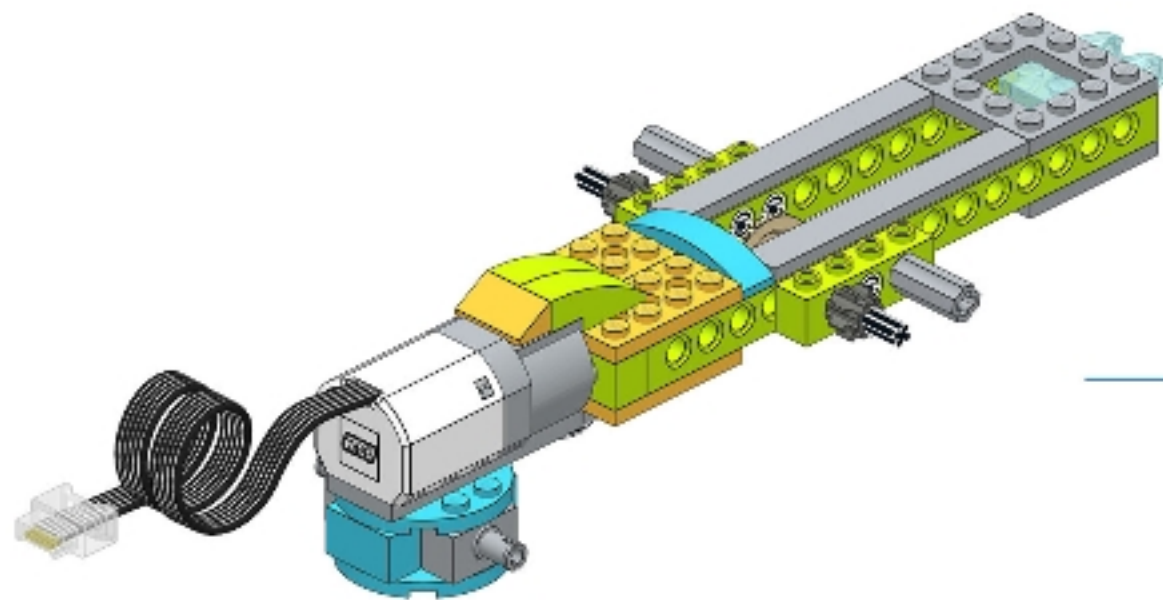

45

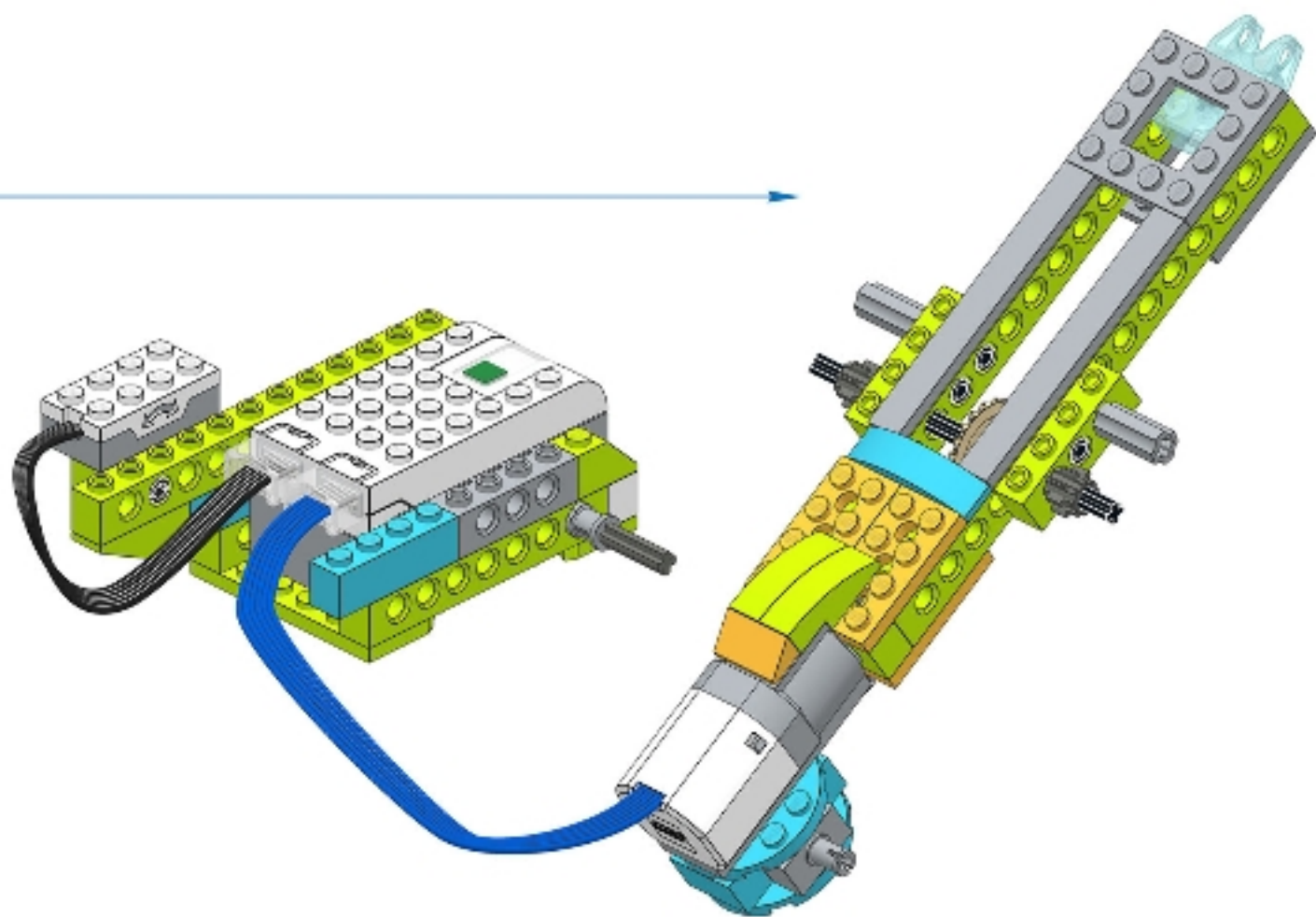

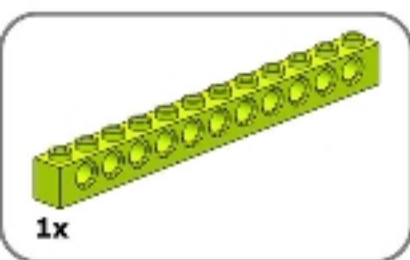

48

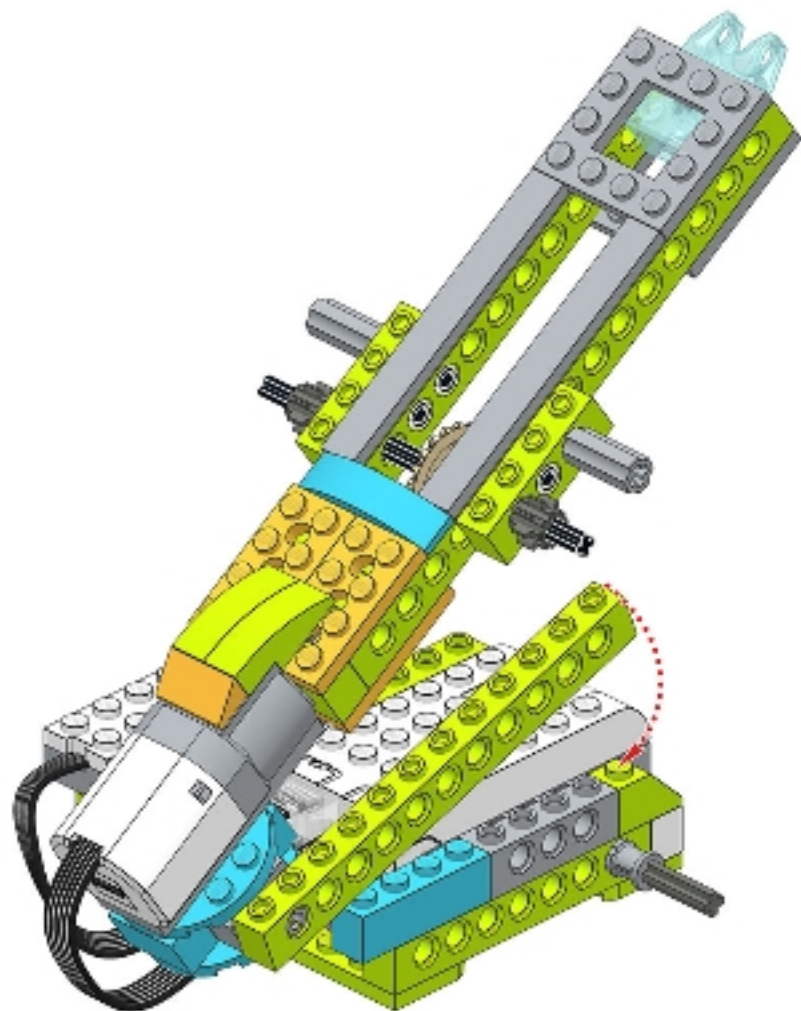

49

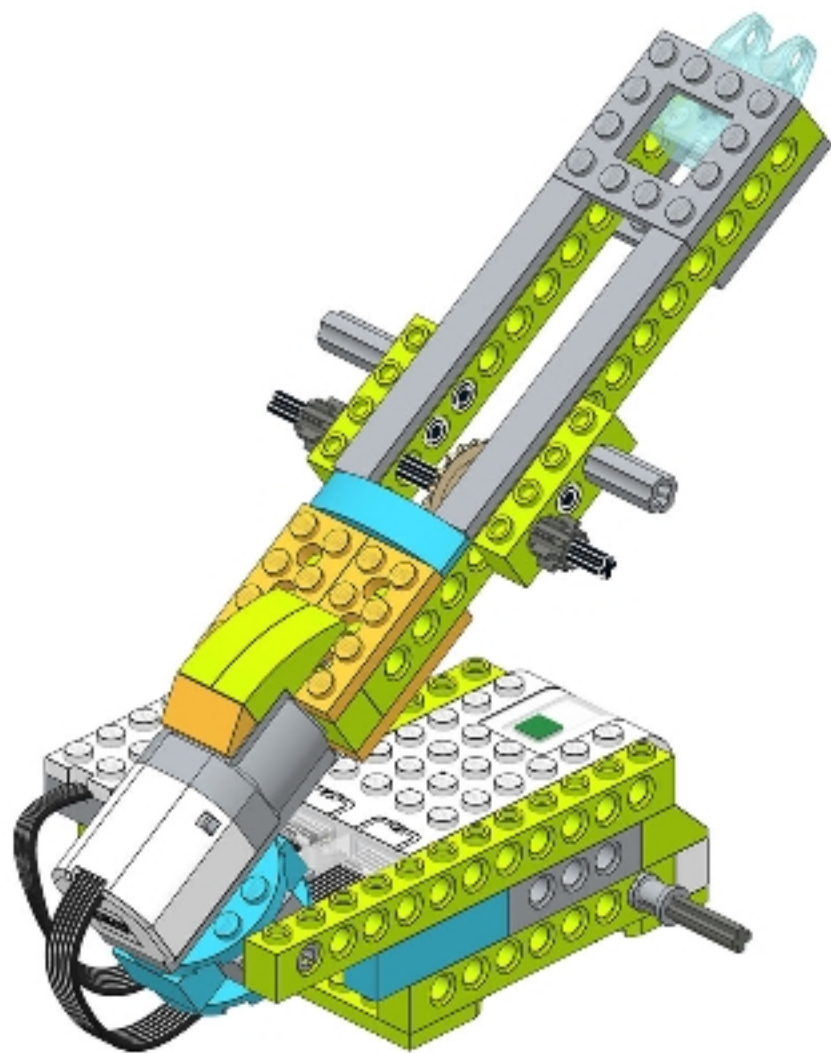

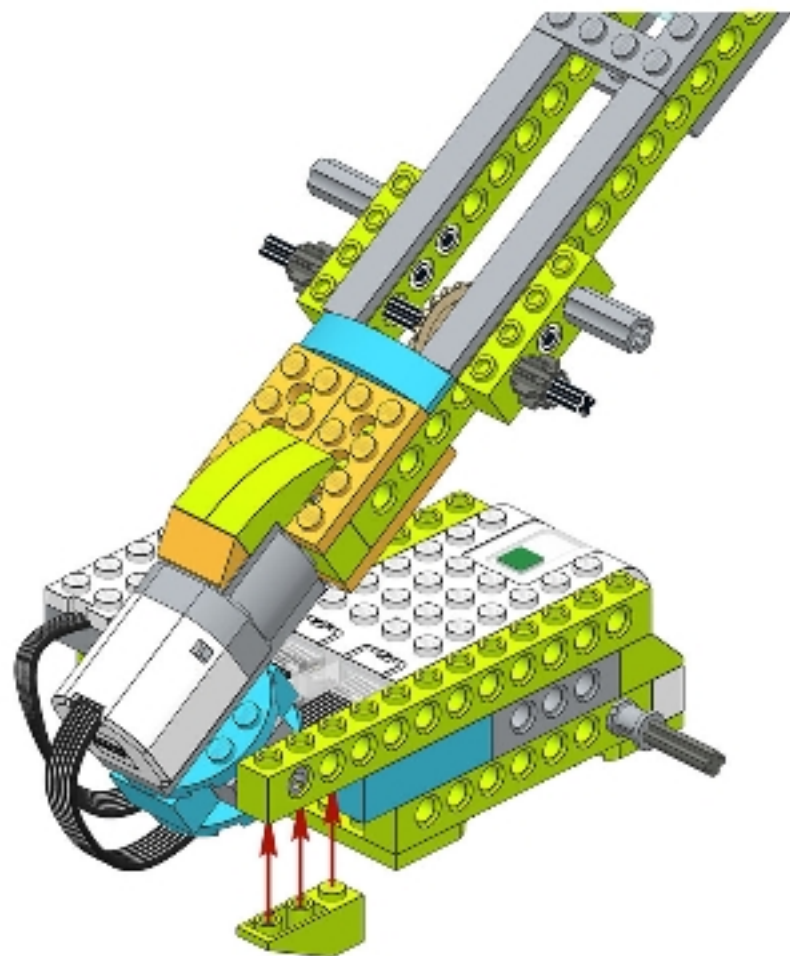

1x

50

51

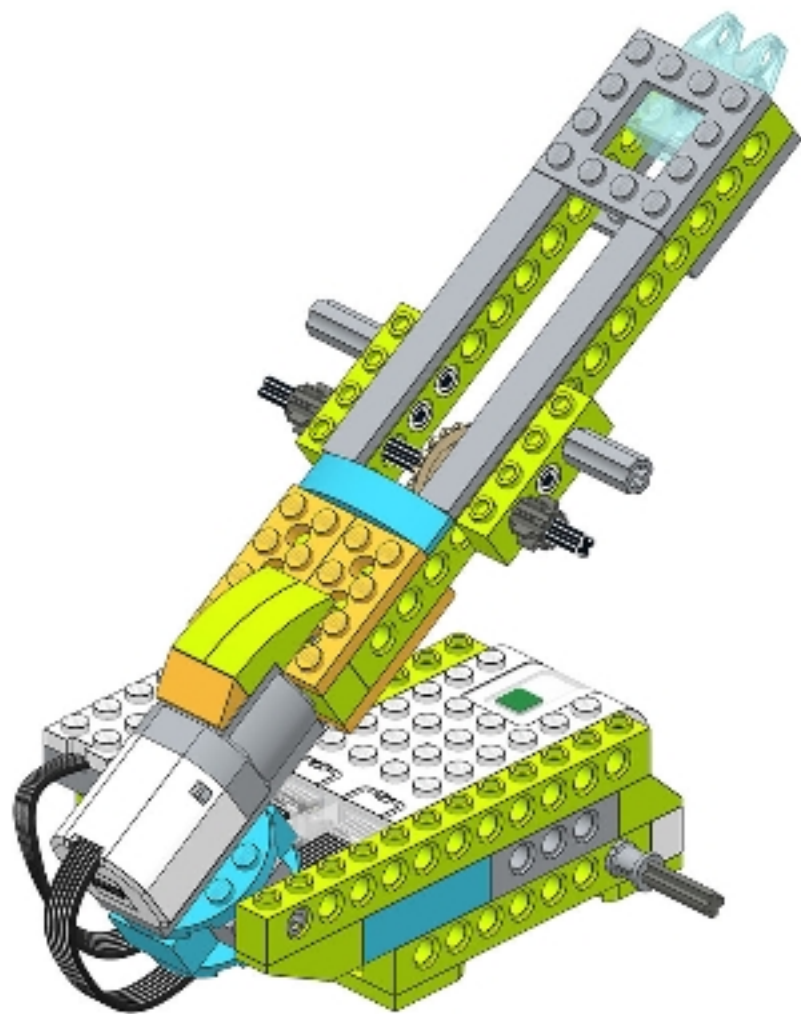



3x



1x

1

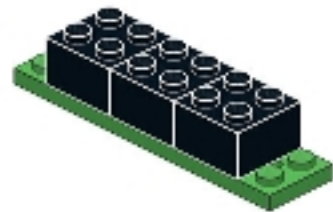

2x

2

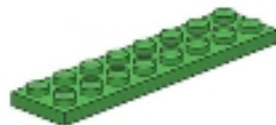
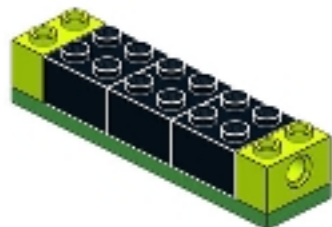

1x

3

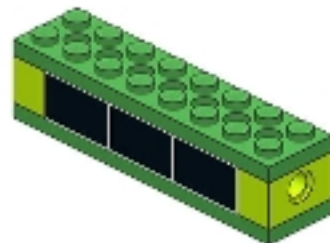

53

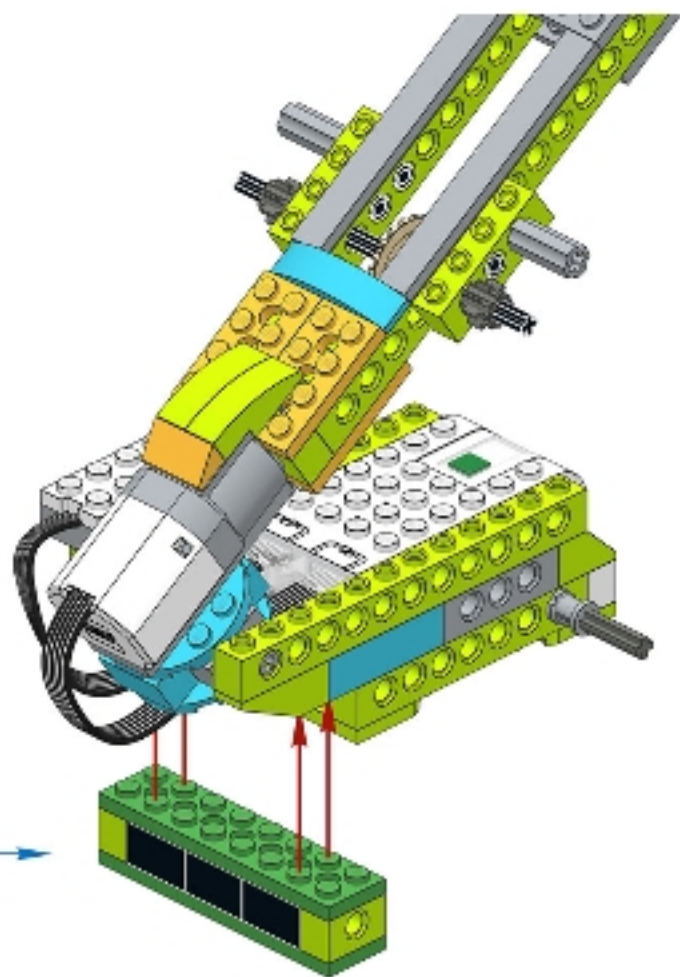

54

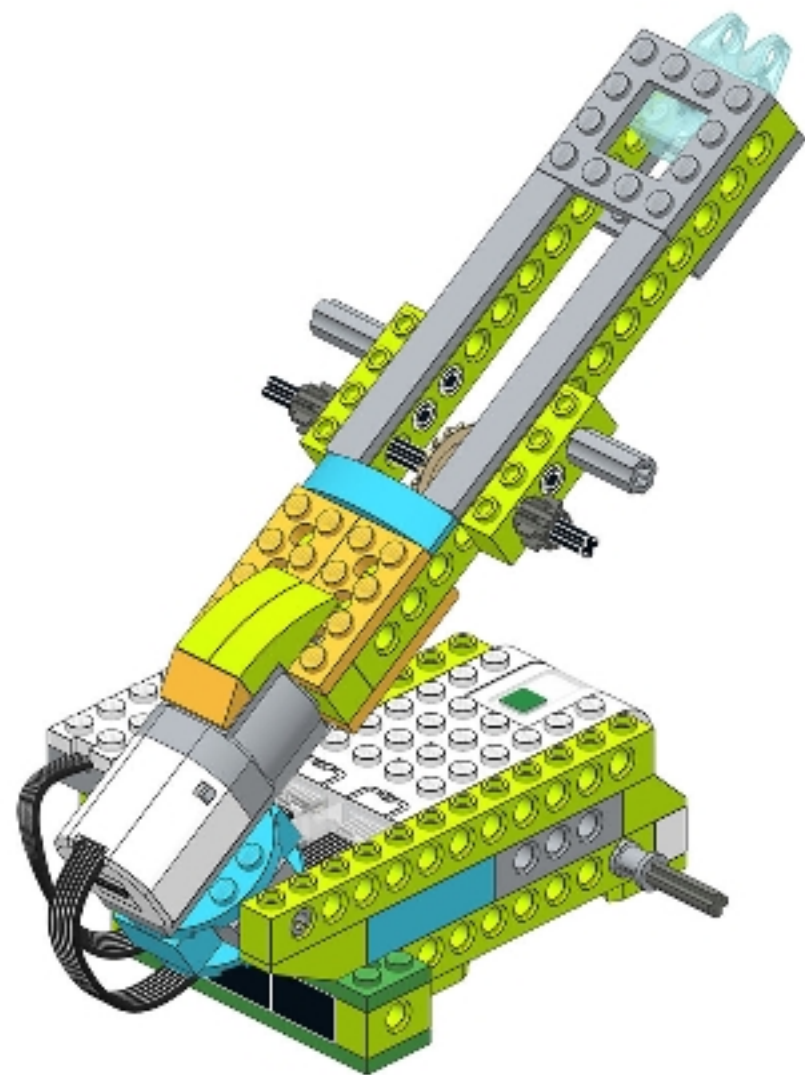

56

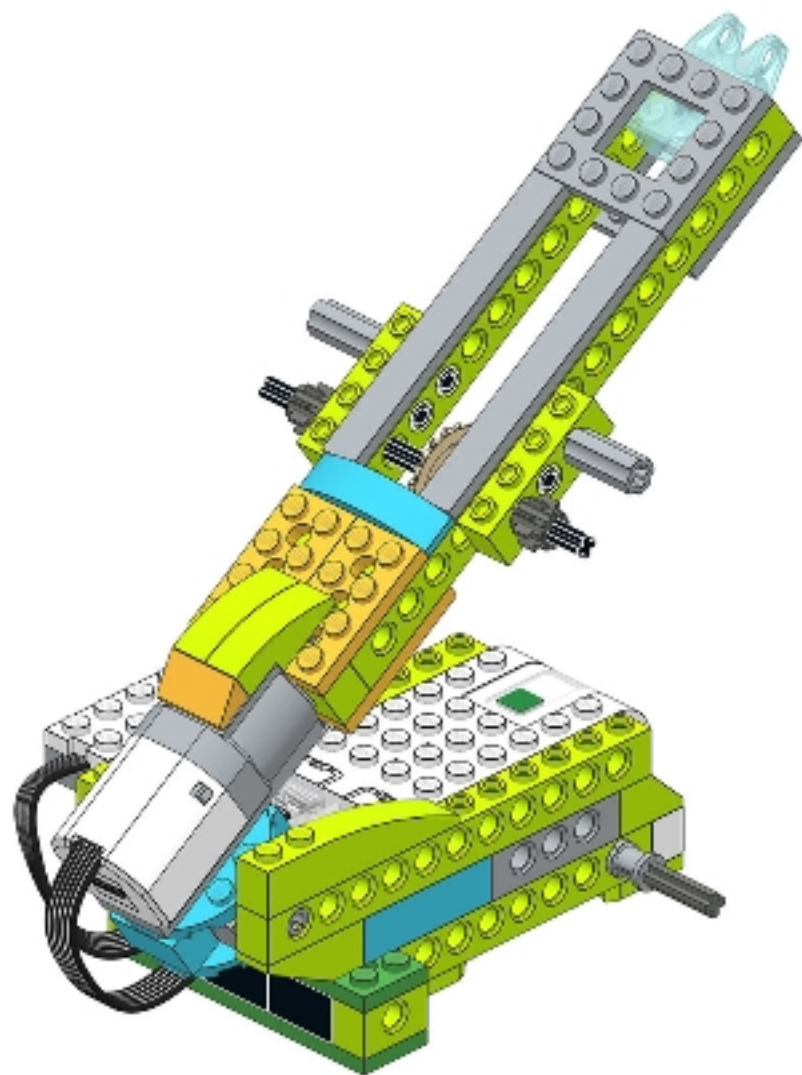

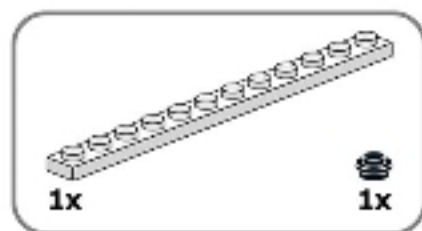
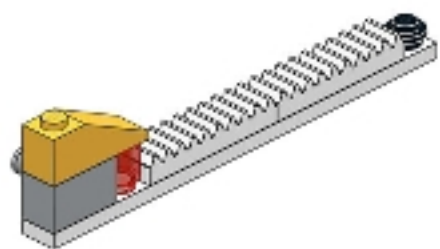

57

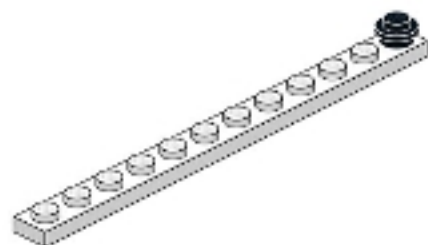

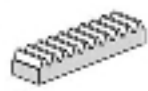

2x

58

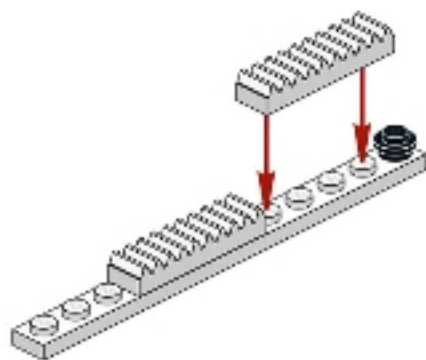



1x



1x

59

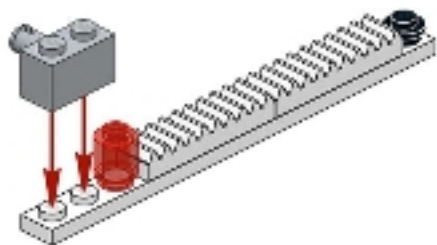



1x

60

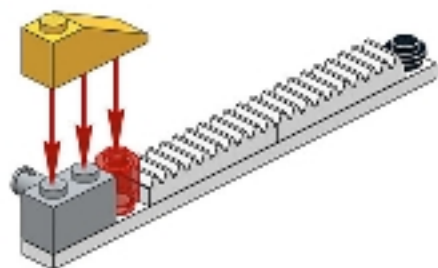

61

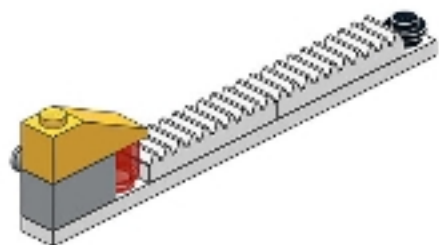

62

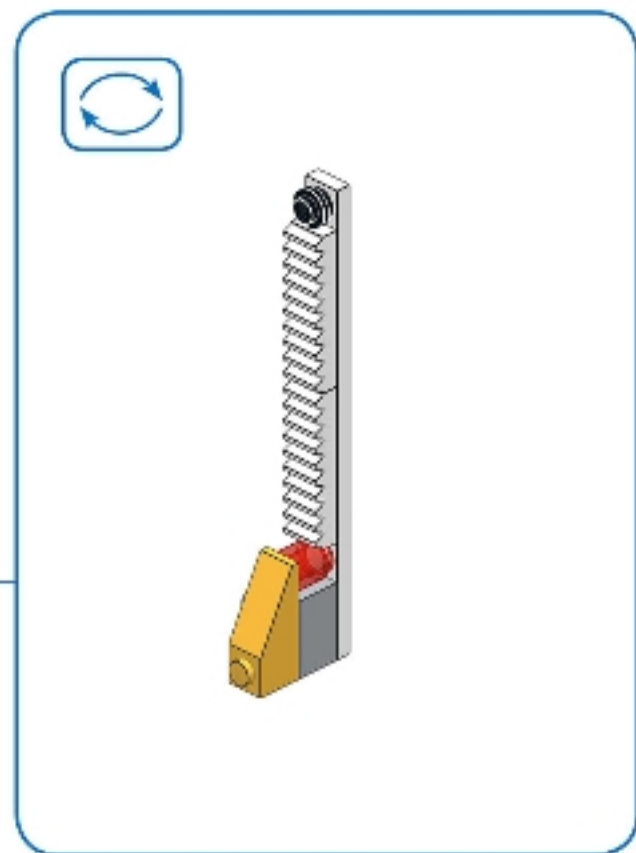
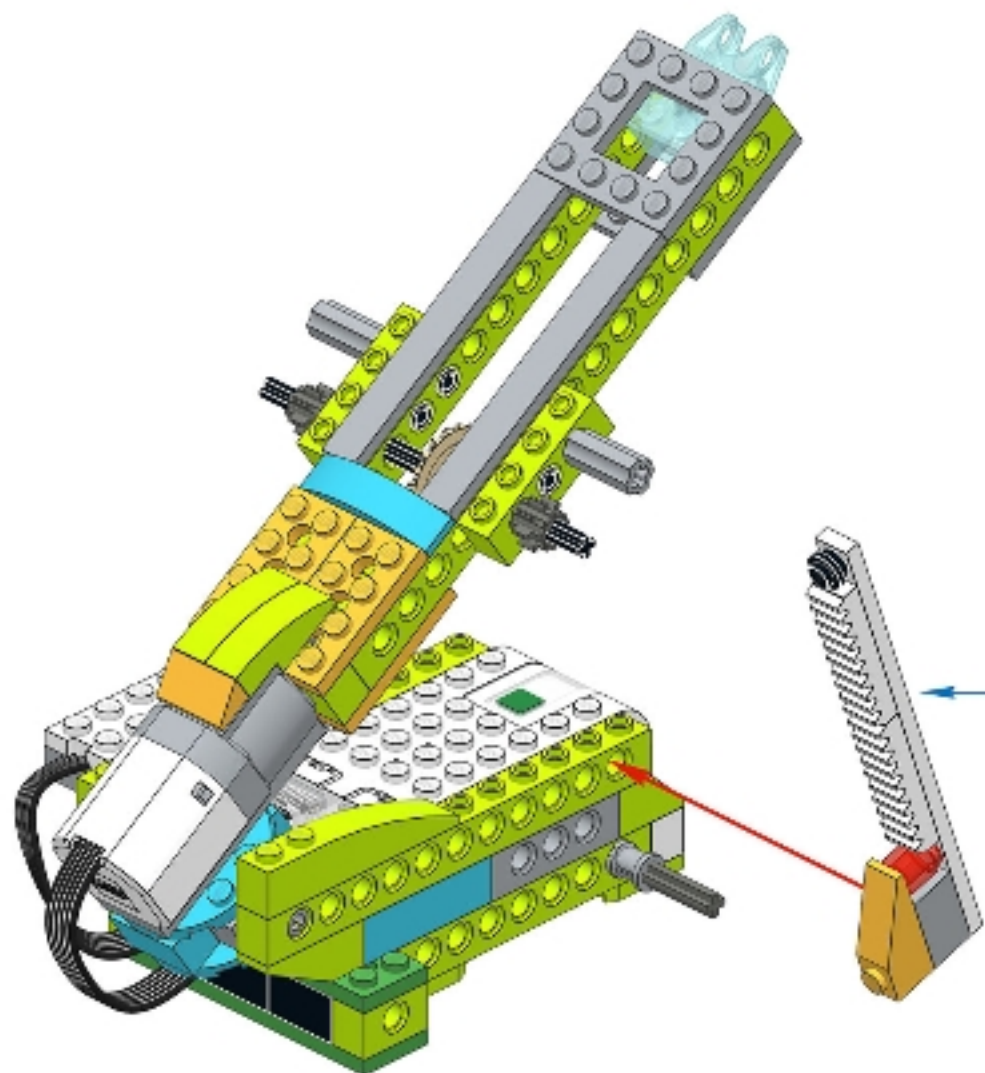

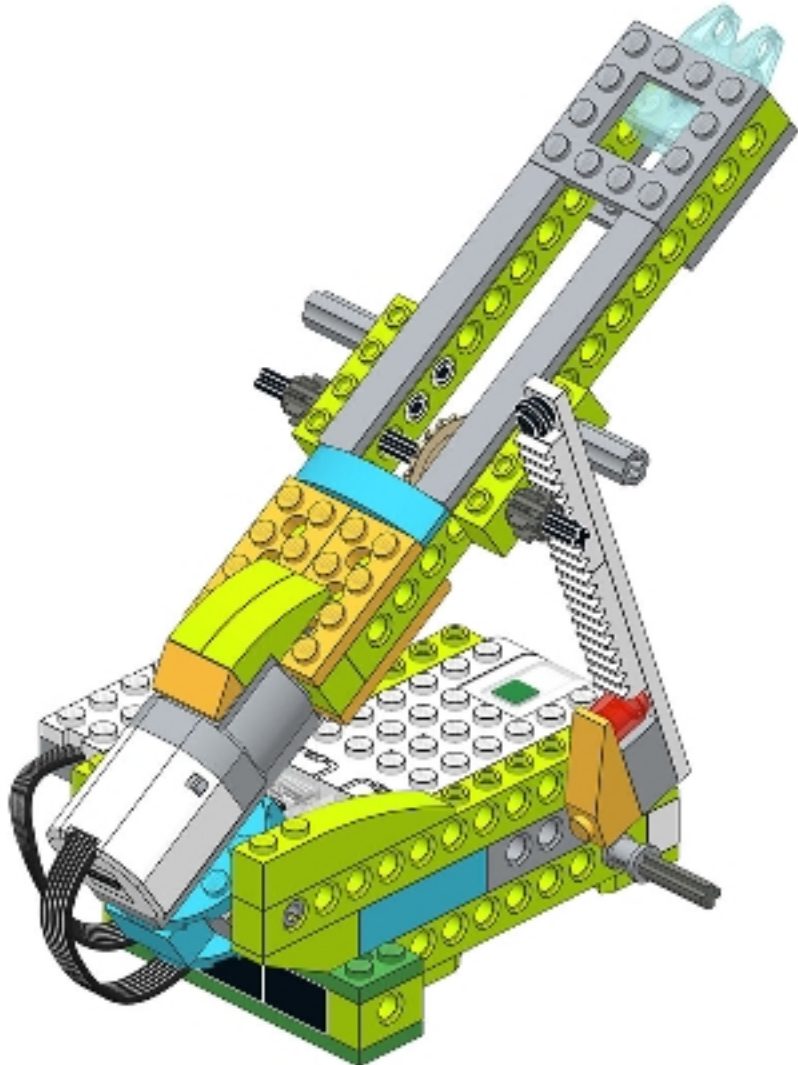

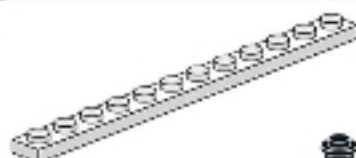
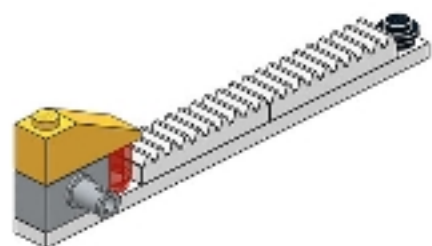

1x



1x

64

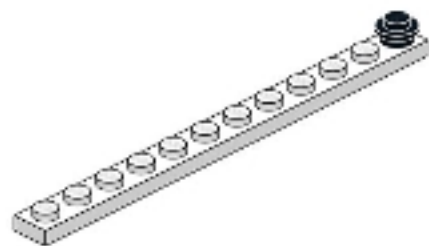

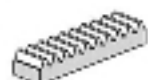

2x

65

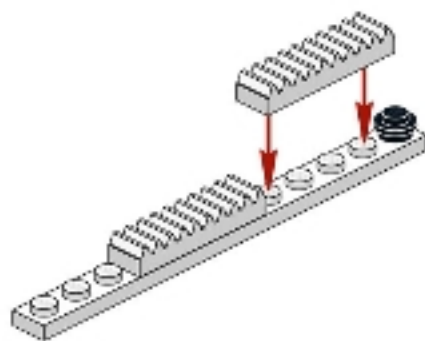

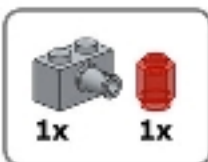

66

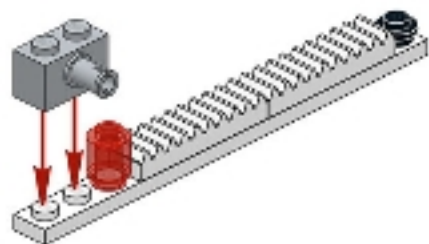



1x

67

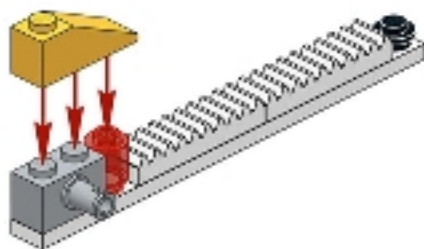

68

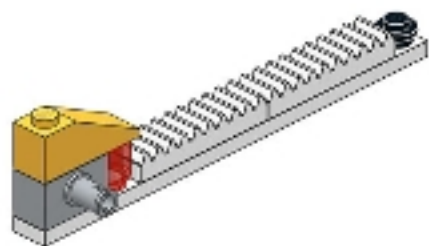

69

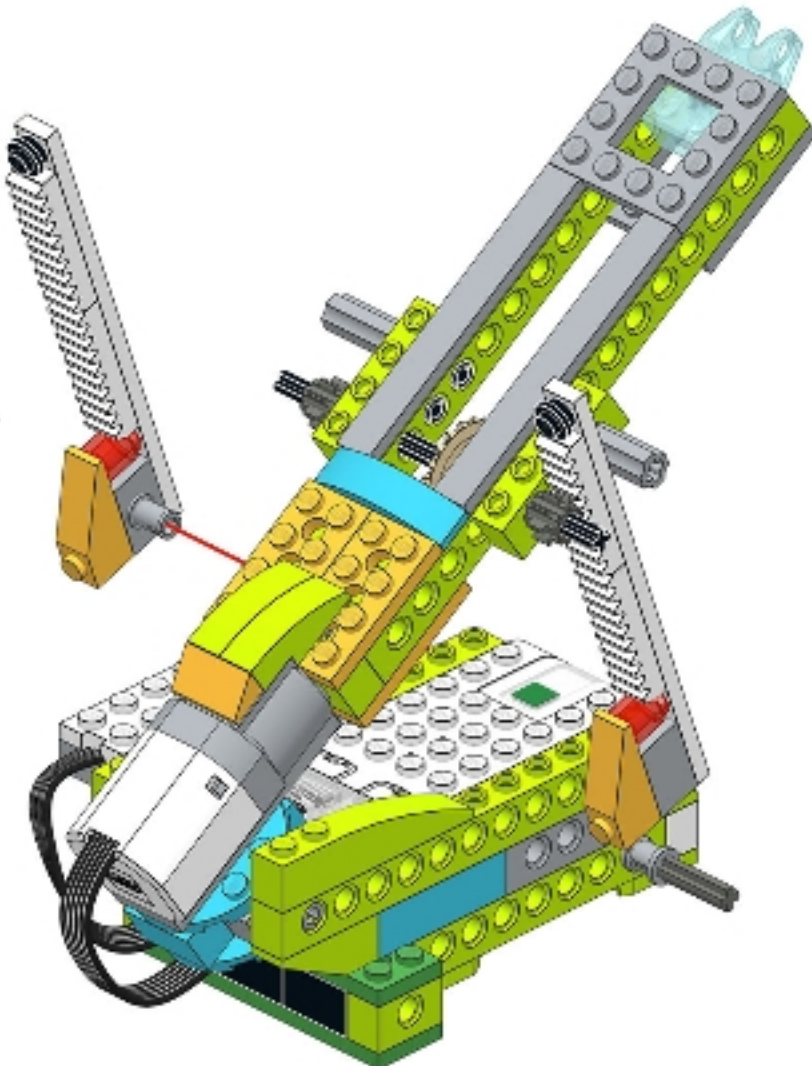

70

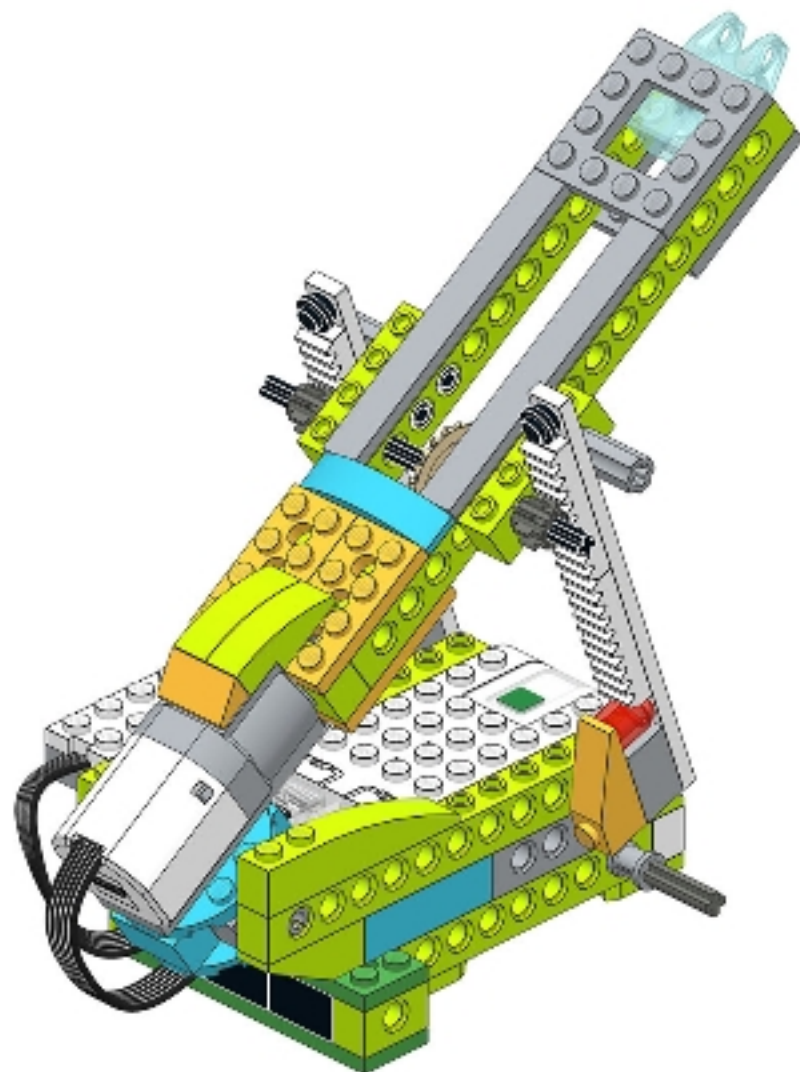



71

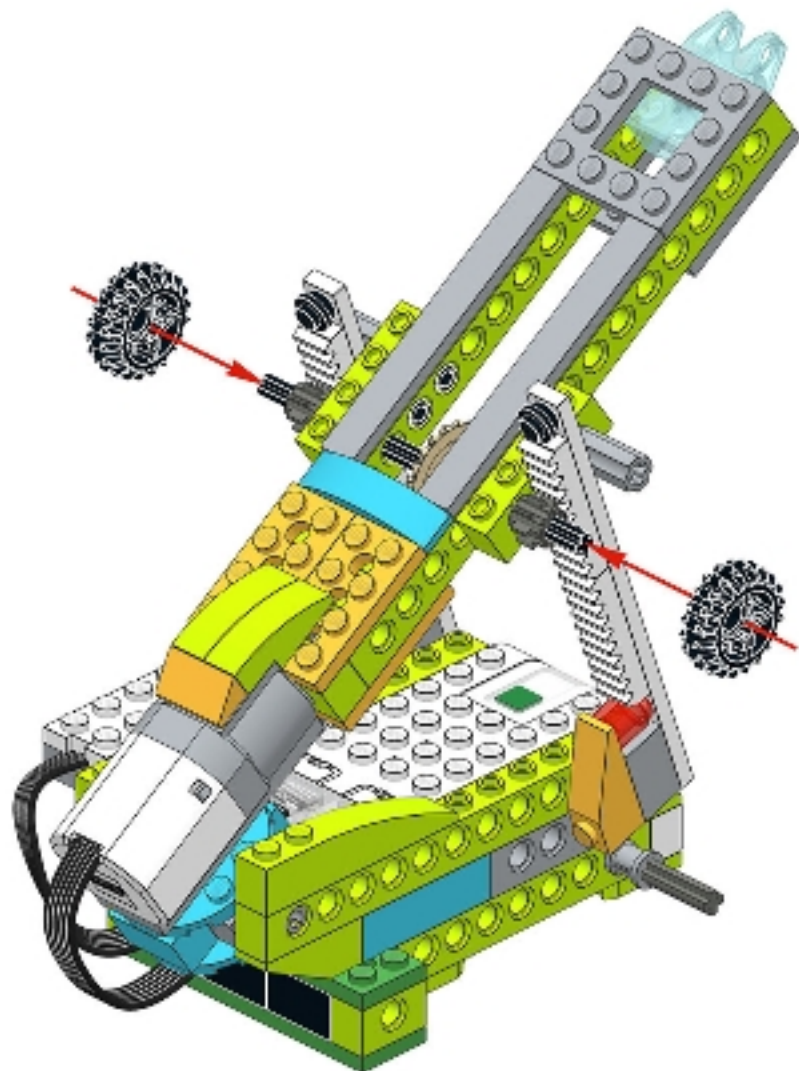

72

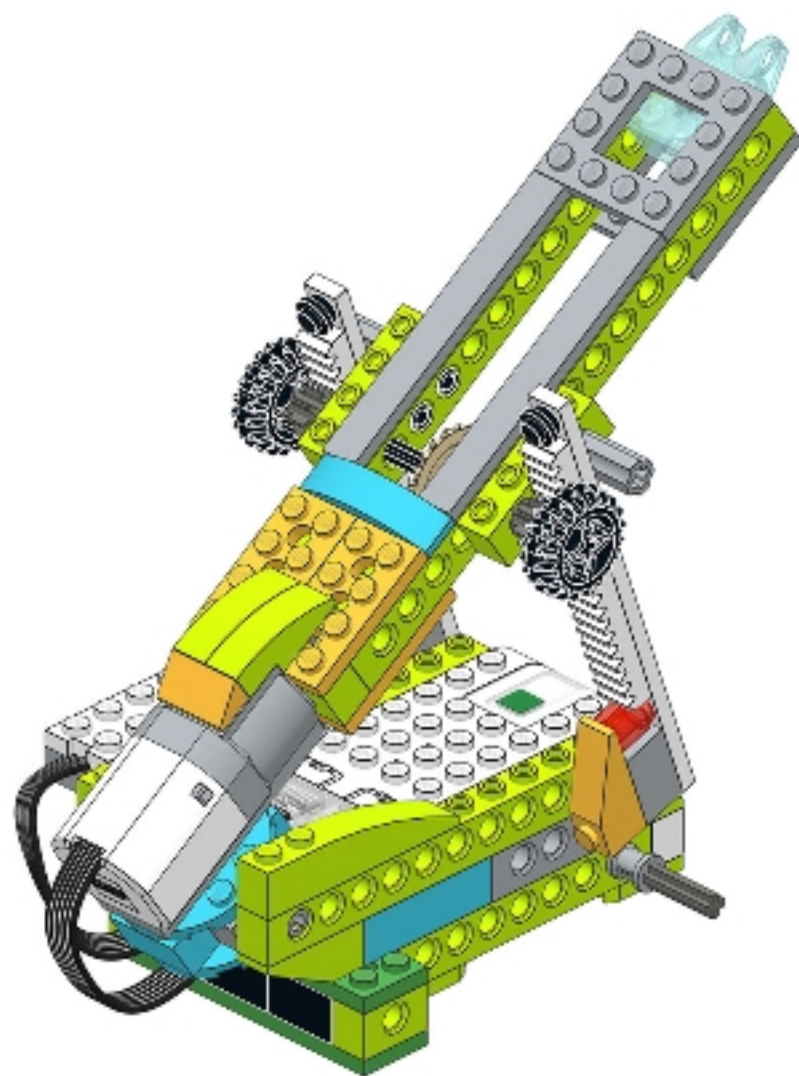

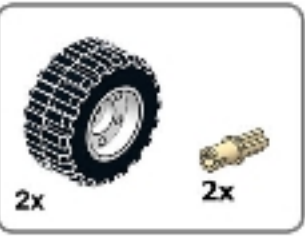

73





2x

75

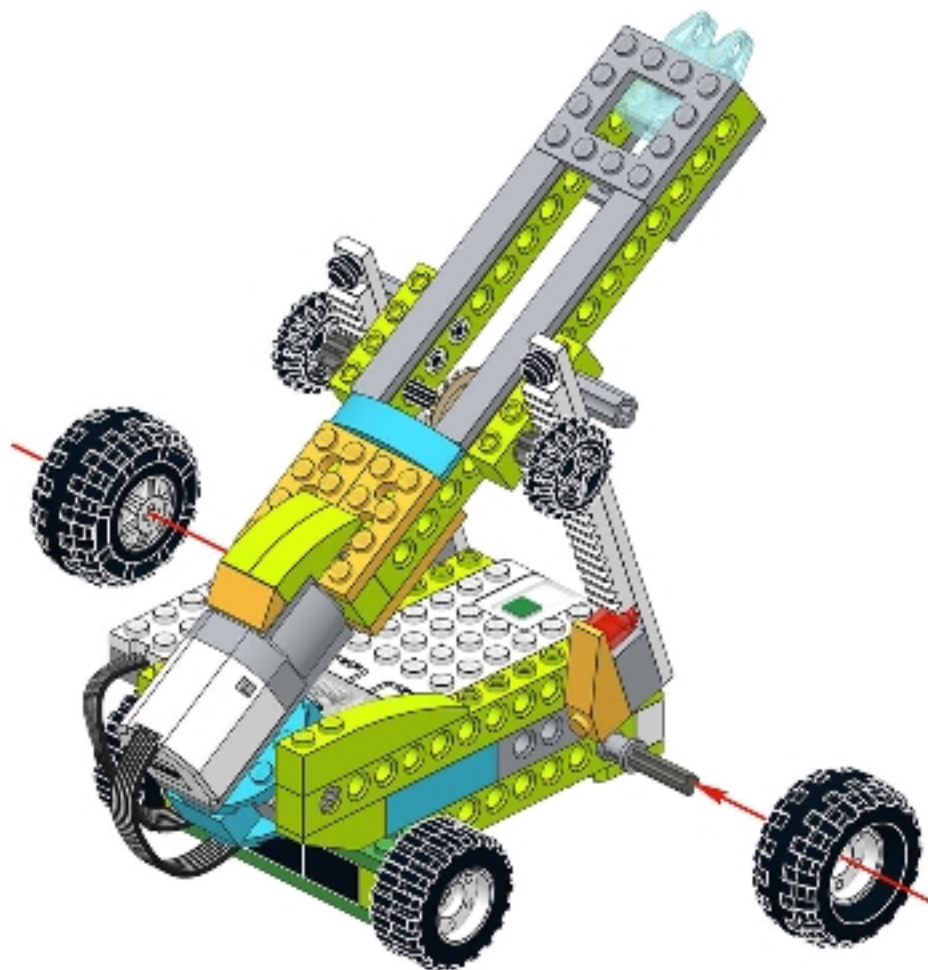

76

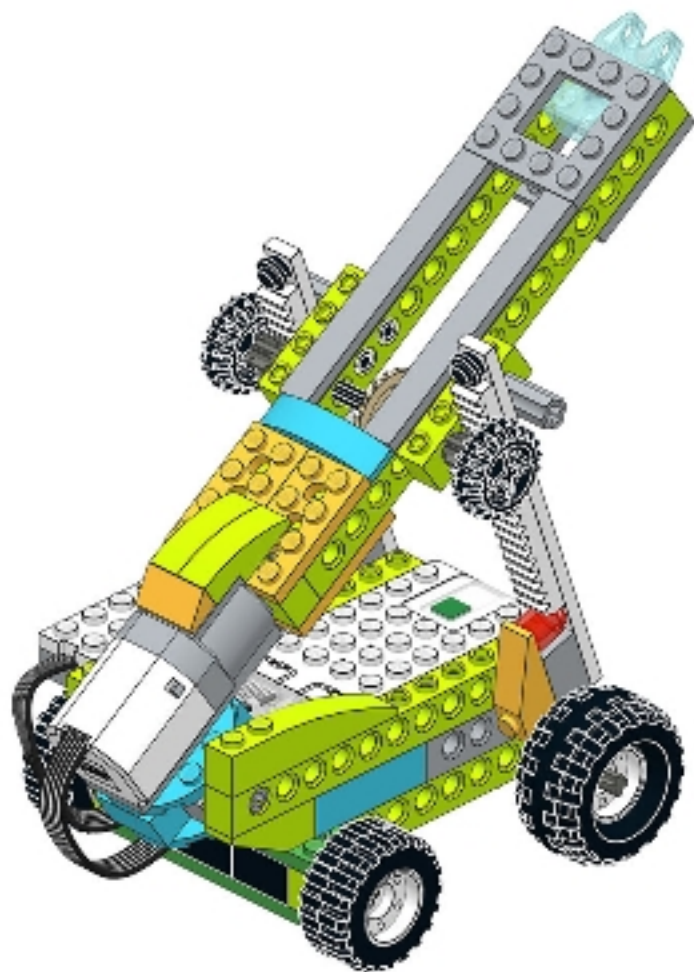

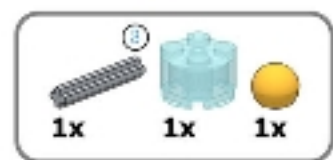

77

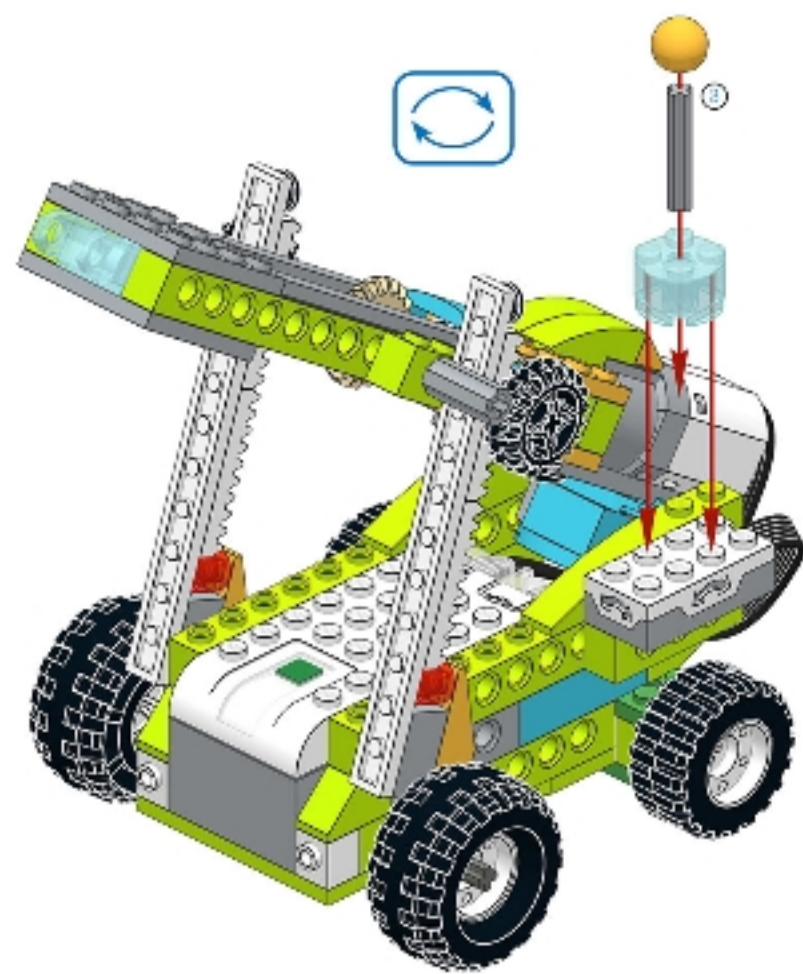

78

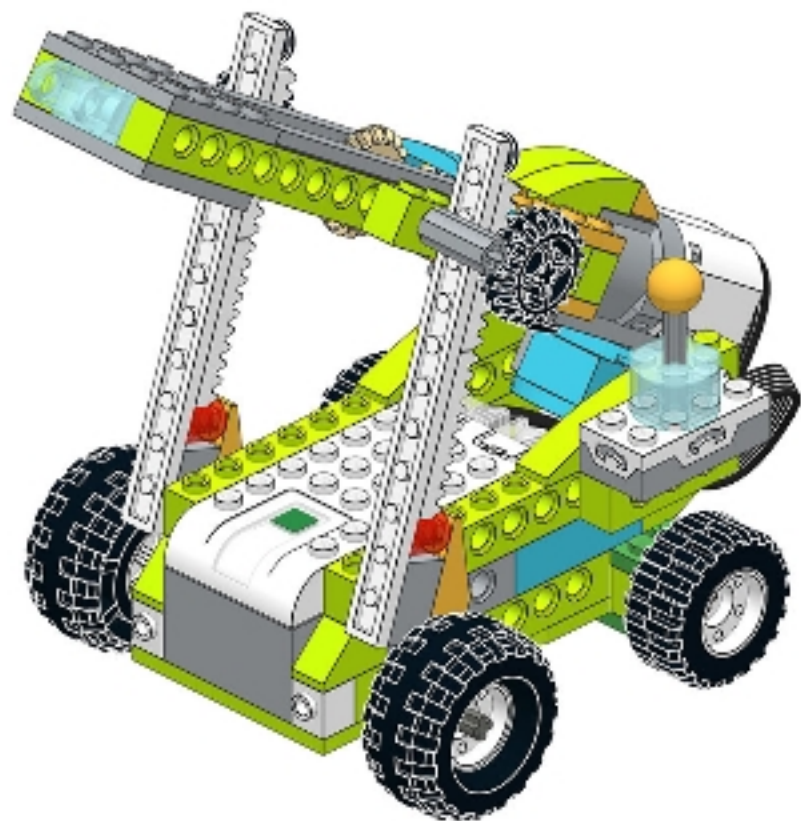

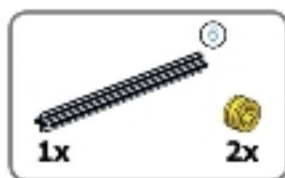

79

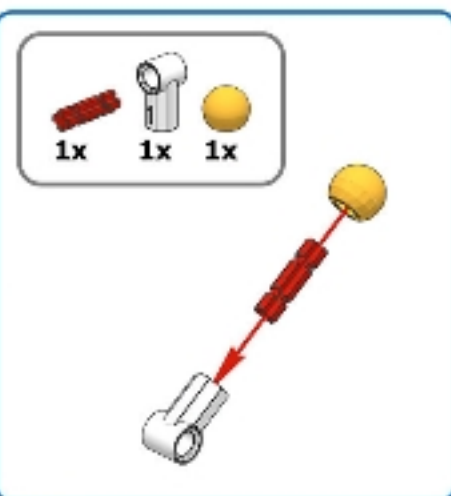
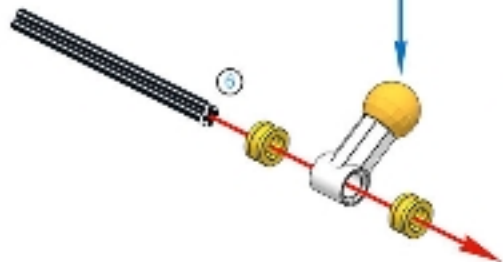

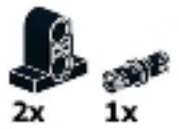

1

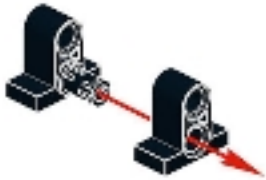

2

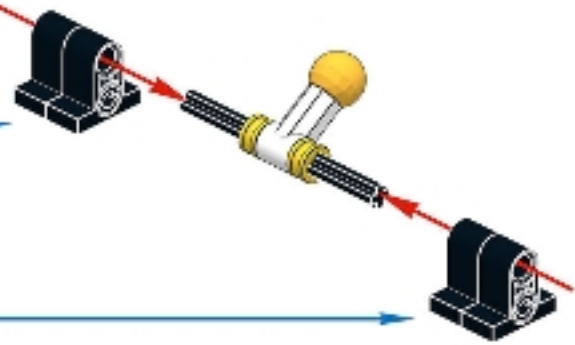



1x

81

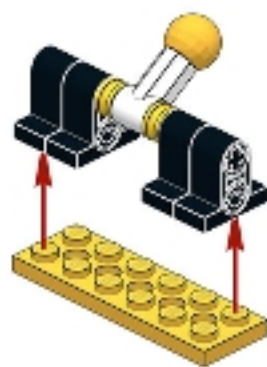



2x

82



83



84

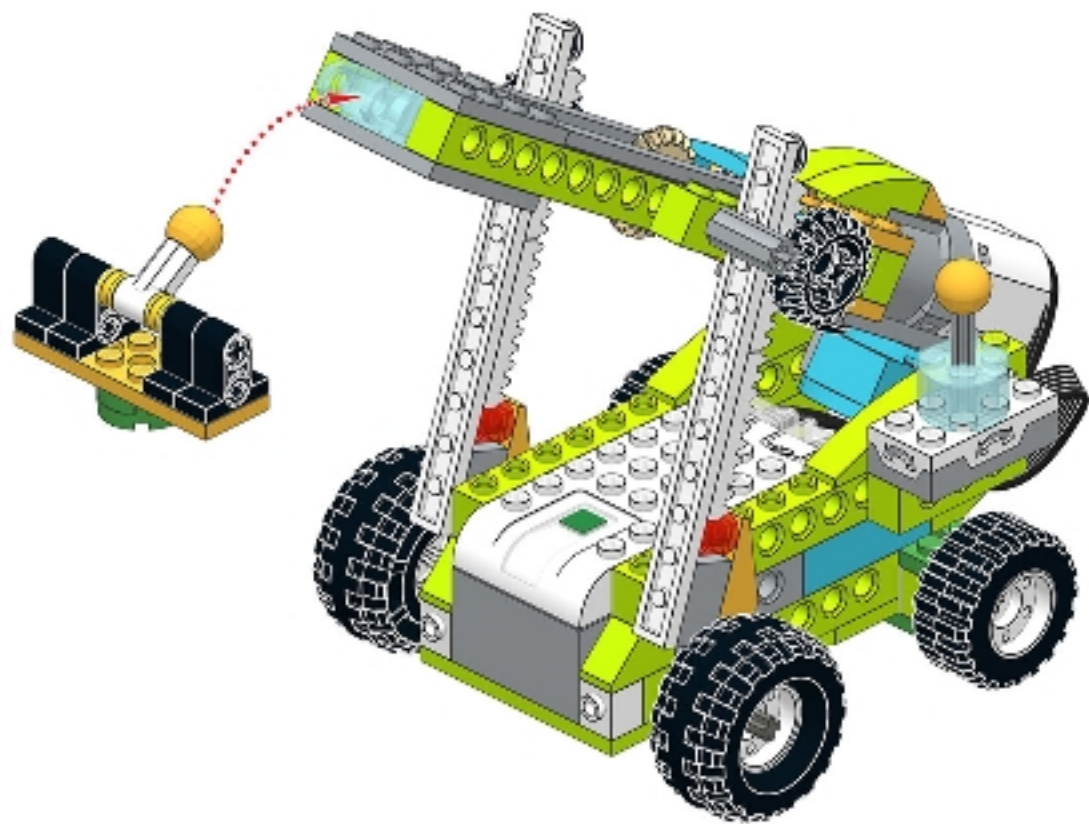

85

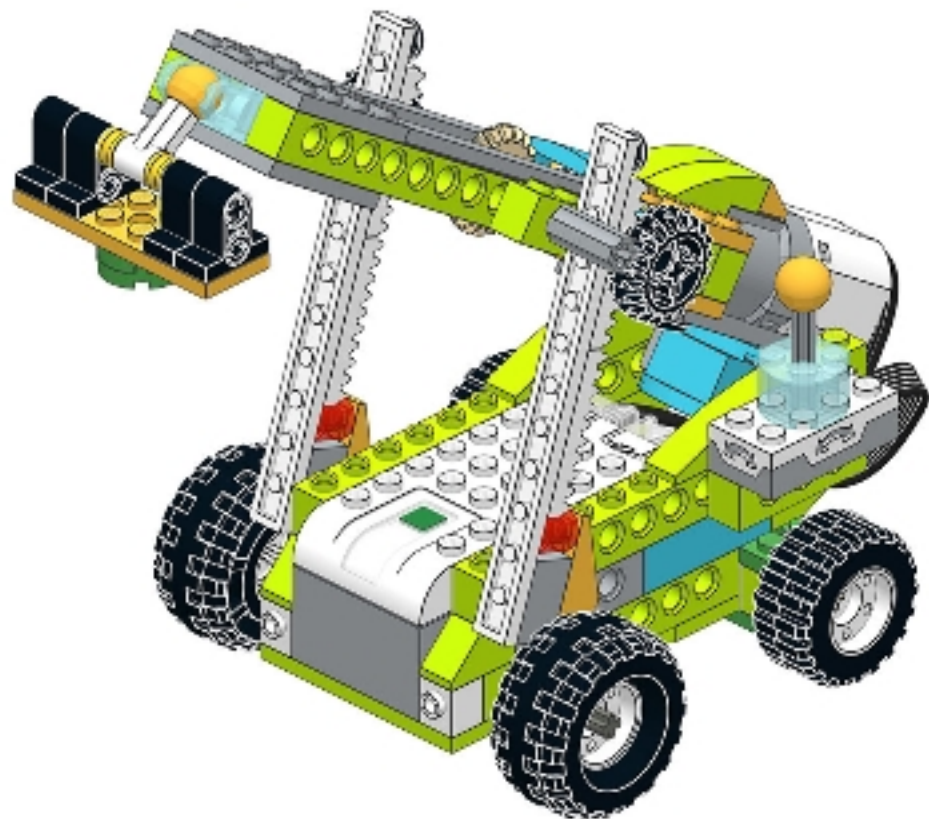



2x

86



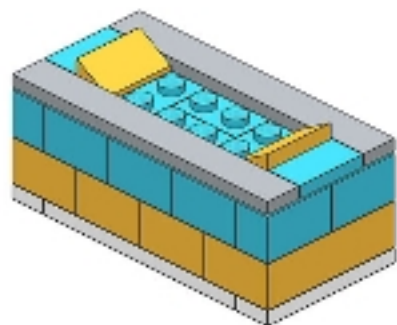

1x

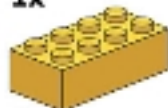

1x

87

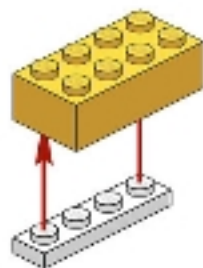



2x

88

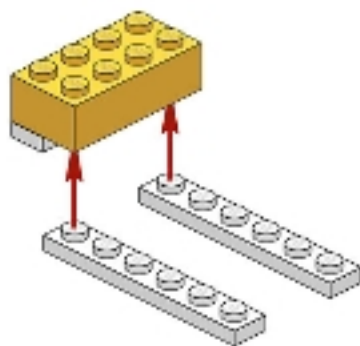



1x

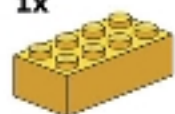

3x

89

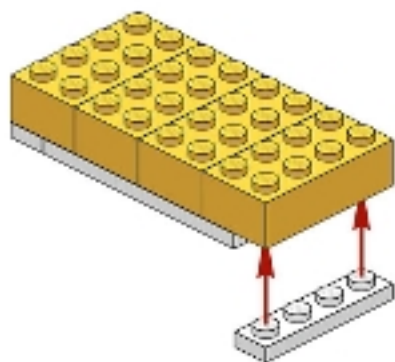



2x

90

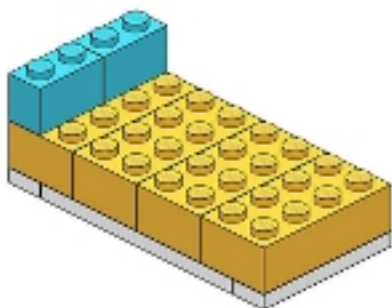

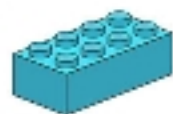

1x

91

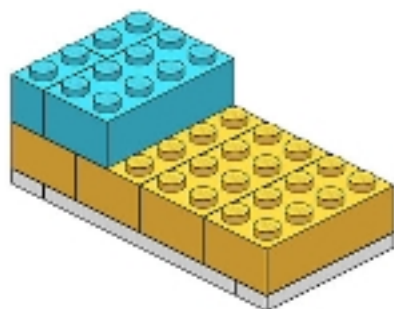



2x

92

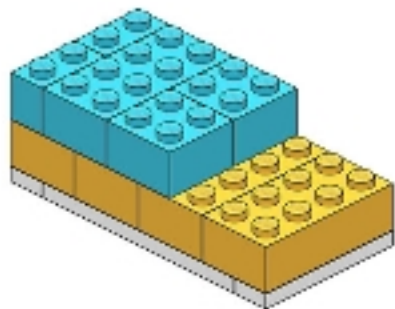

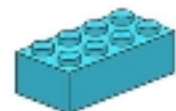

1x

93

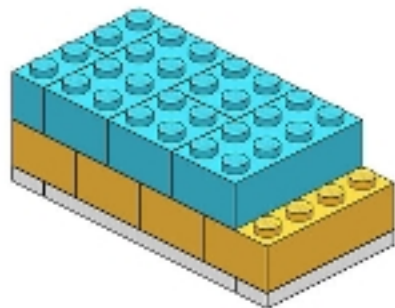



2x

94

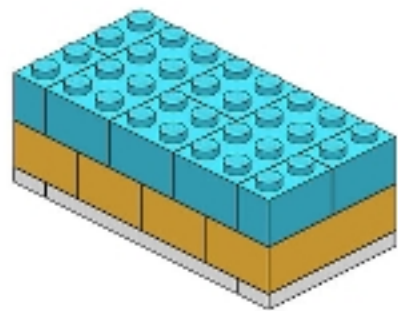



2x

95

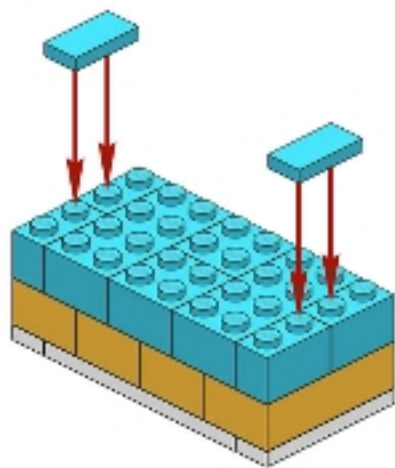



2x

96

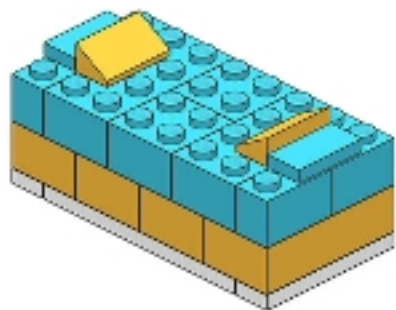

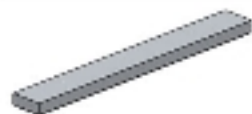

2x

97

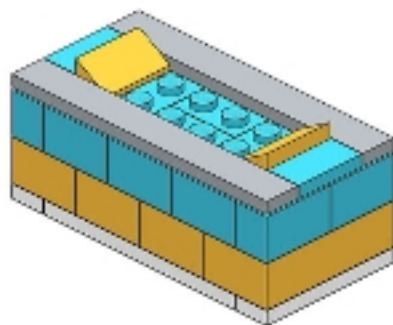

98

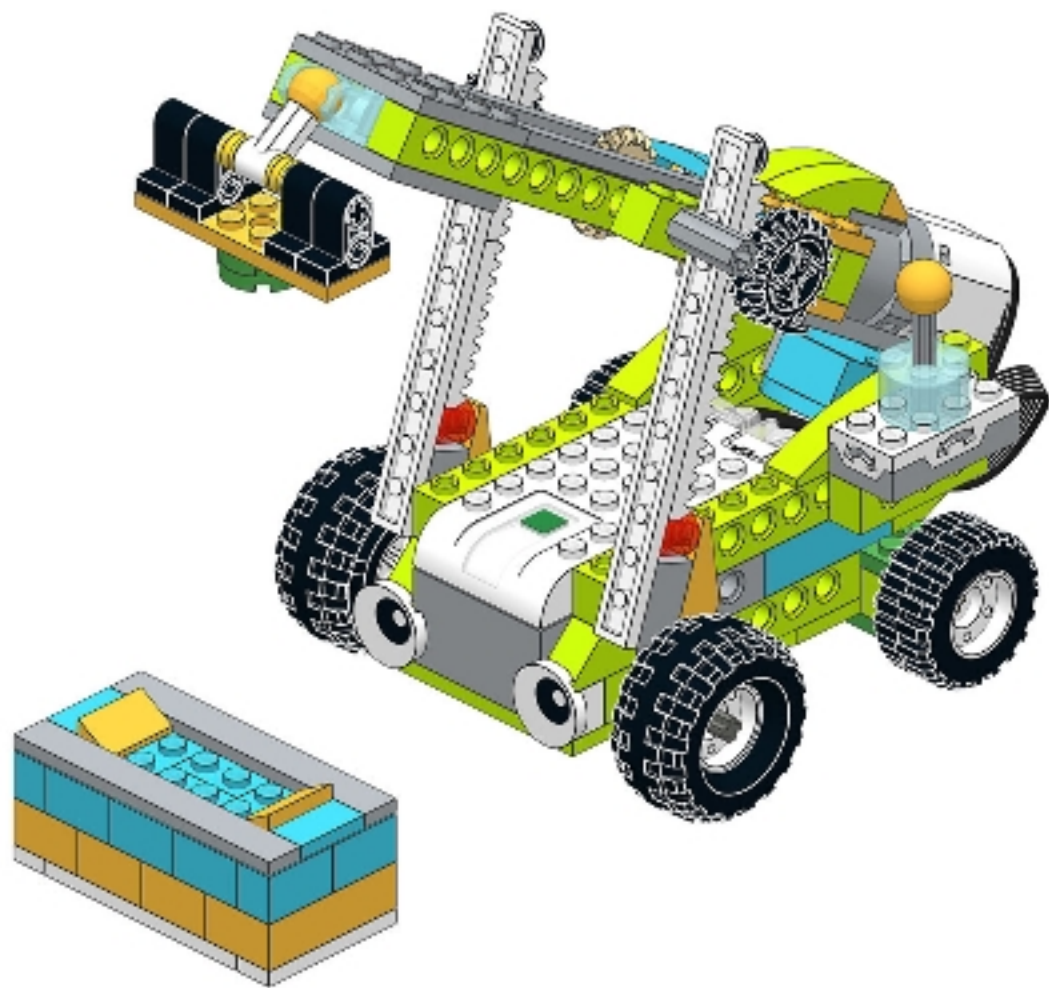



Task 1. Program

Write the program for controlling the manipulator using the example below and test the robot.



In order to control the manipulator more precisely, it is convenient to use a low speed. In our case - "1".



Task 2. Program

Modify your program and test your robot!

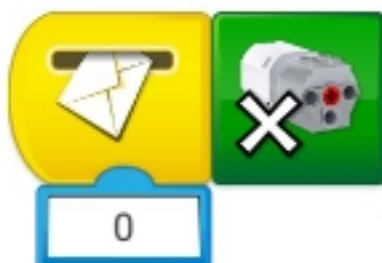

Run the program above will be a program that continuously transmit sensor readings:





Task 2. Questions

Which program block sends sensor data? Click on it.

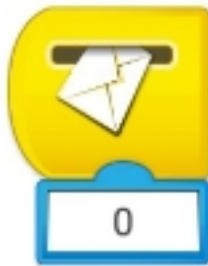
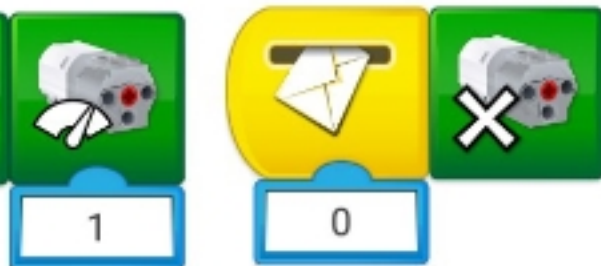



Task 3. Questions

Which program block sets the direction of rotation of the motor axis?

