

Legoati

Anti crash system



Academia creativa de tecnología

Tecnoaprendo

1

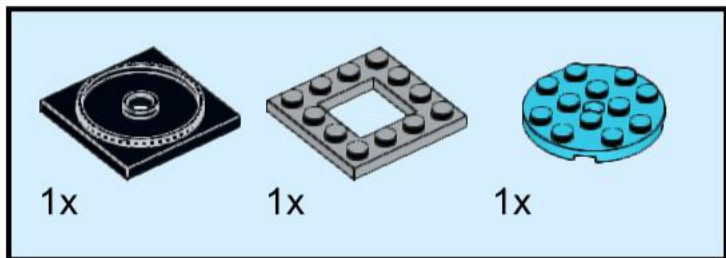

2

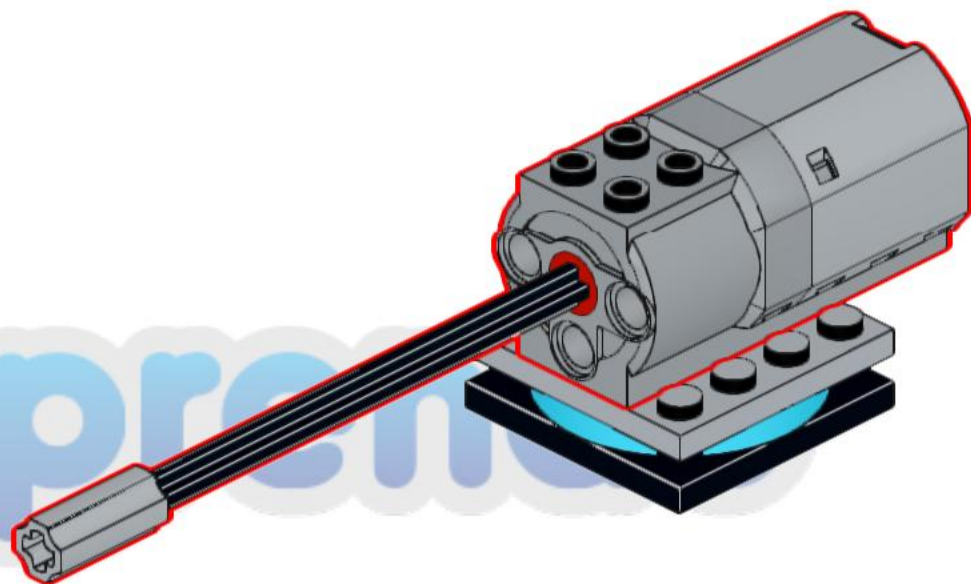
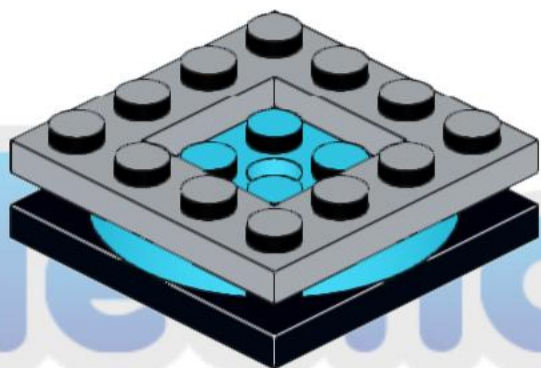
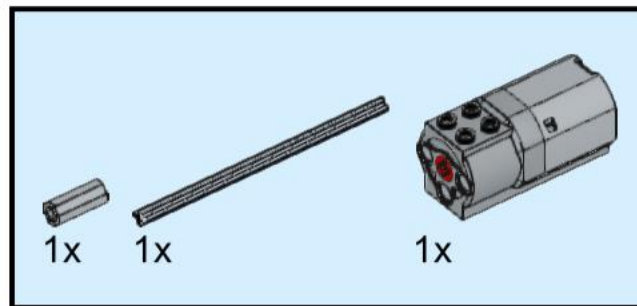

techoaprens

3

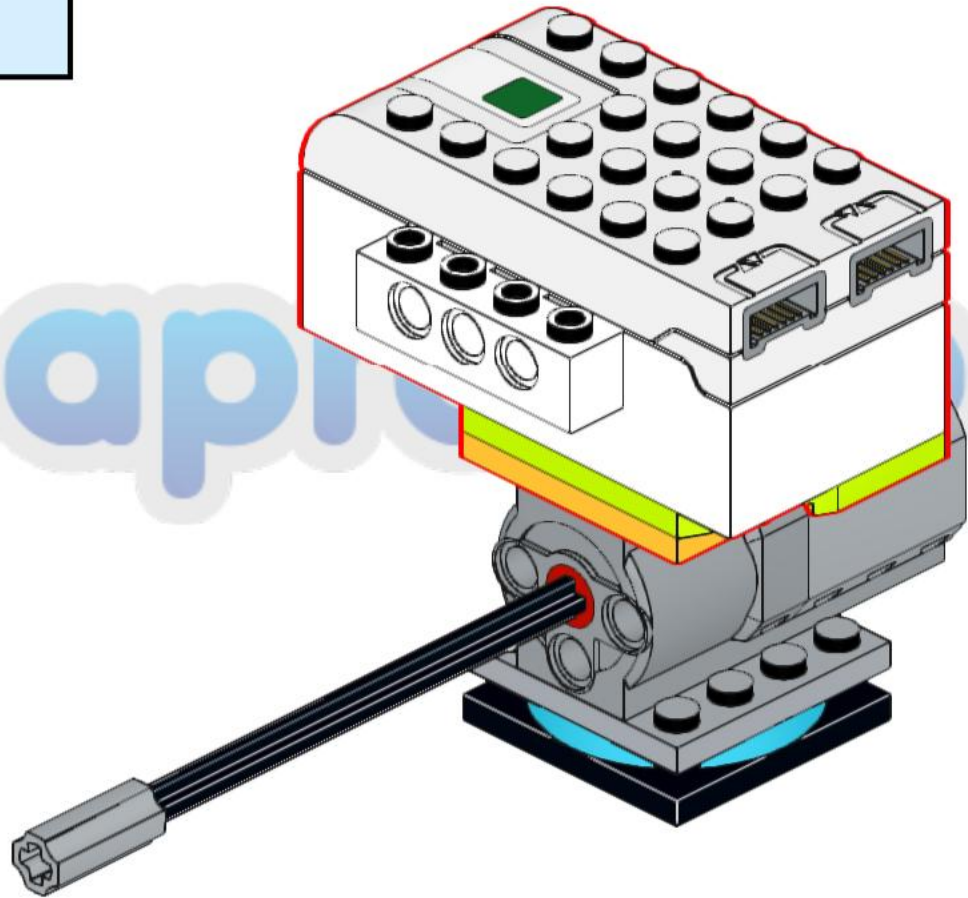
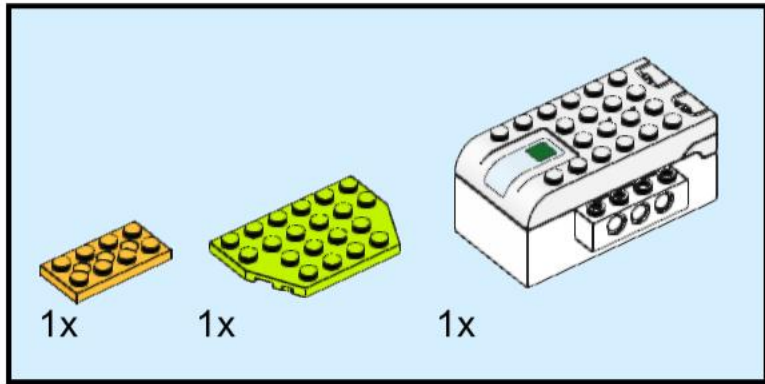

Tecnoap

4

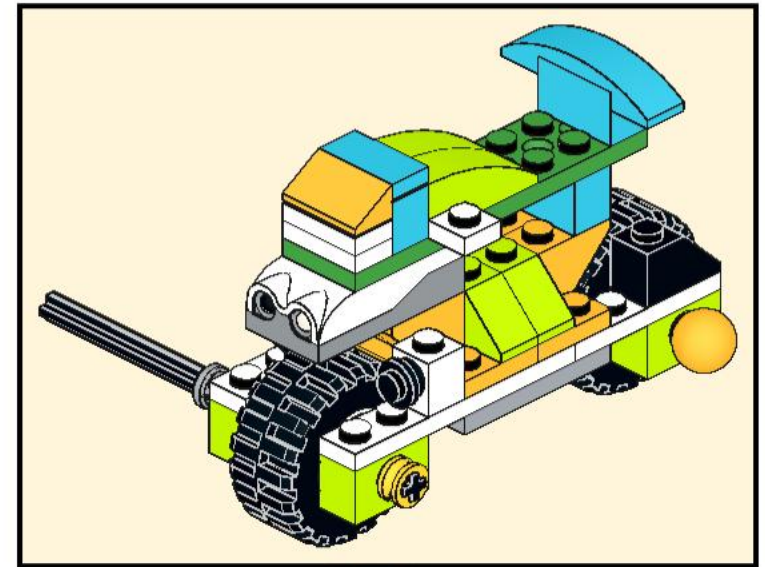
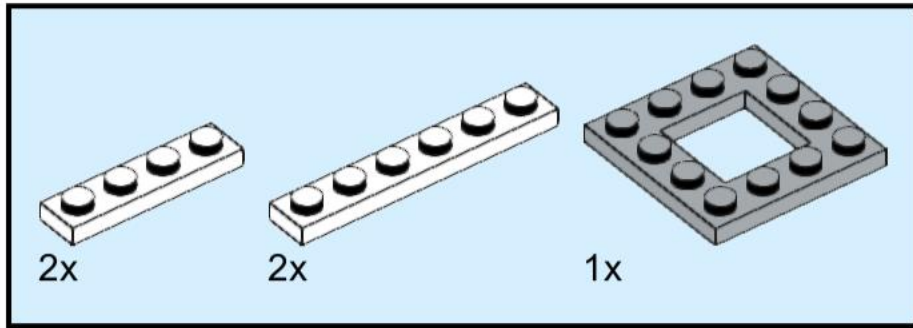

Tecnica aprendo

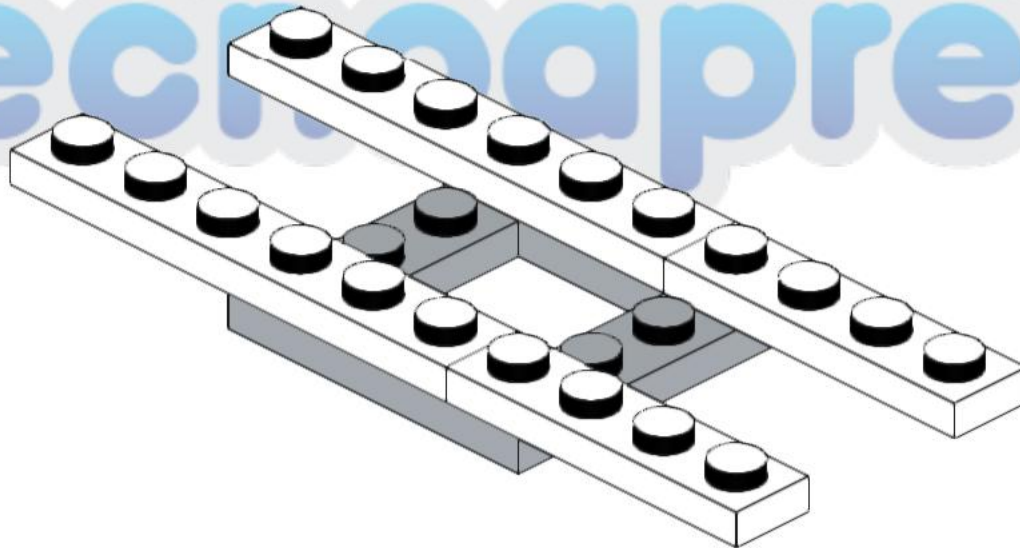

5

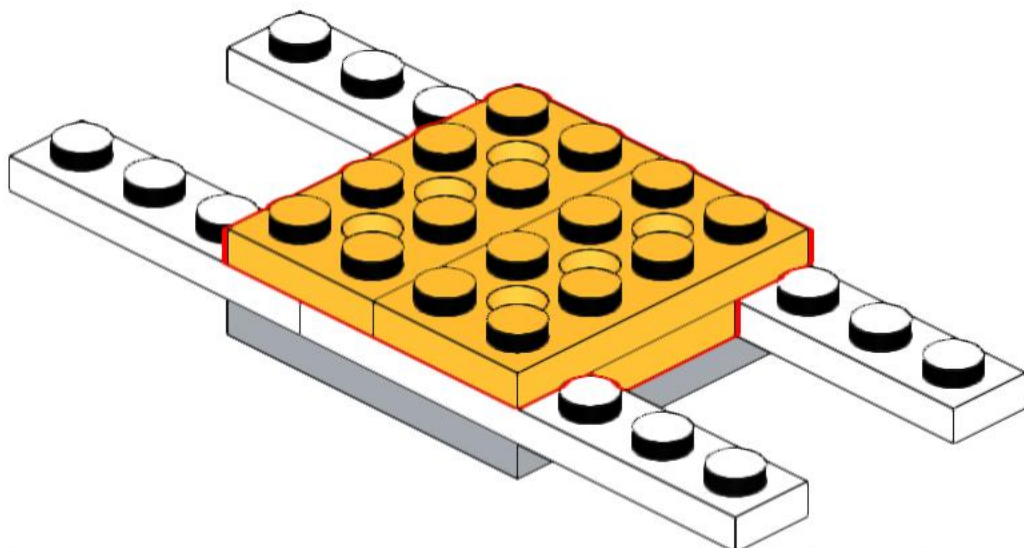
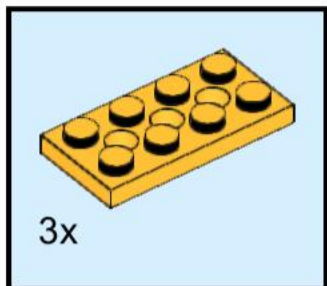

6

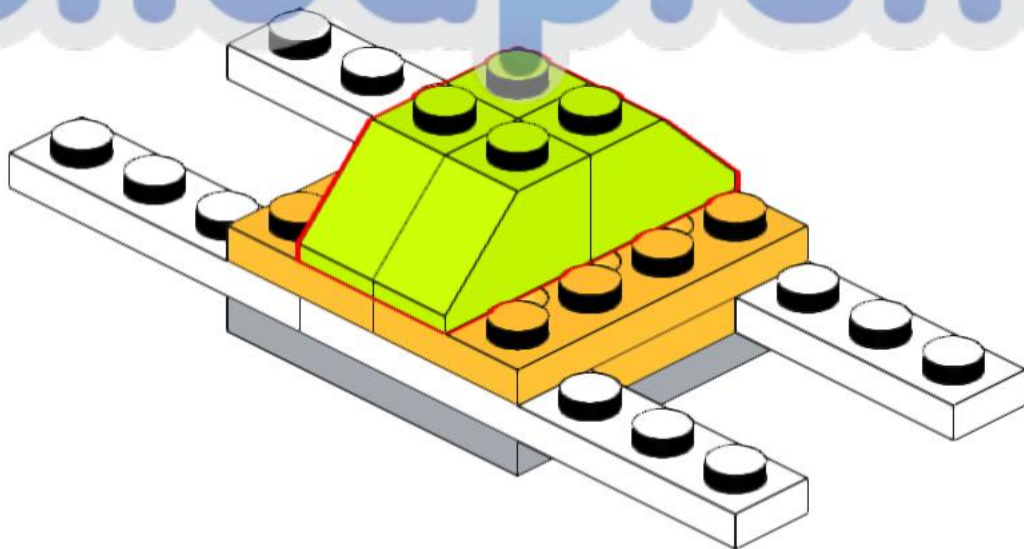
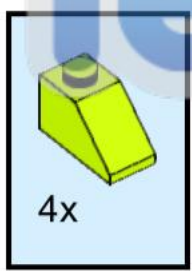

Tecnoaprendo

7

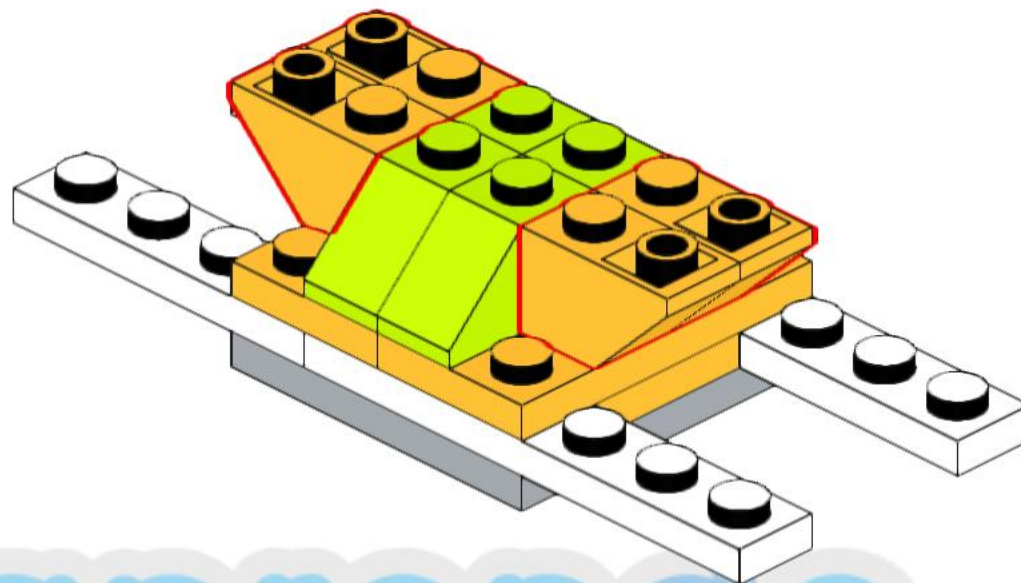
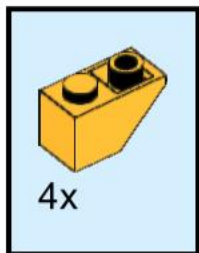

8

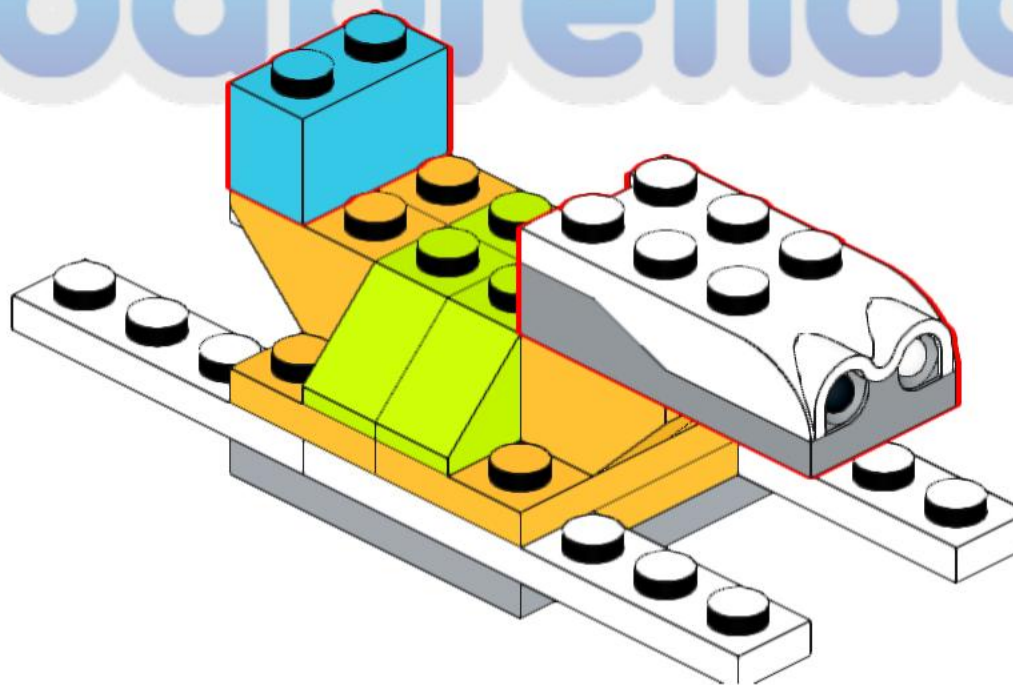
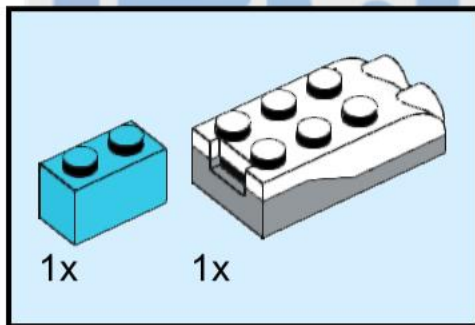

Tecnoprendo

9

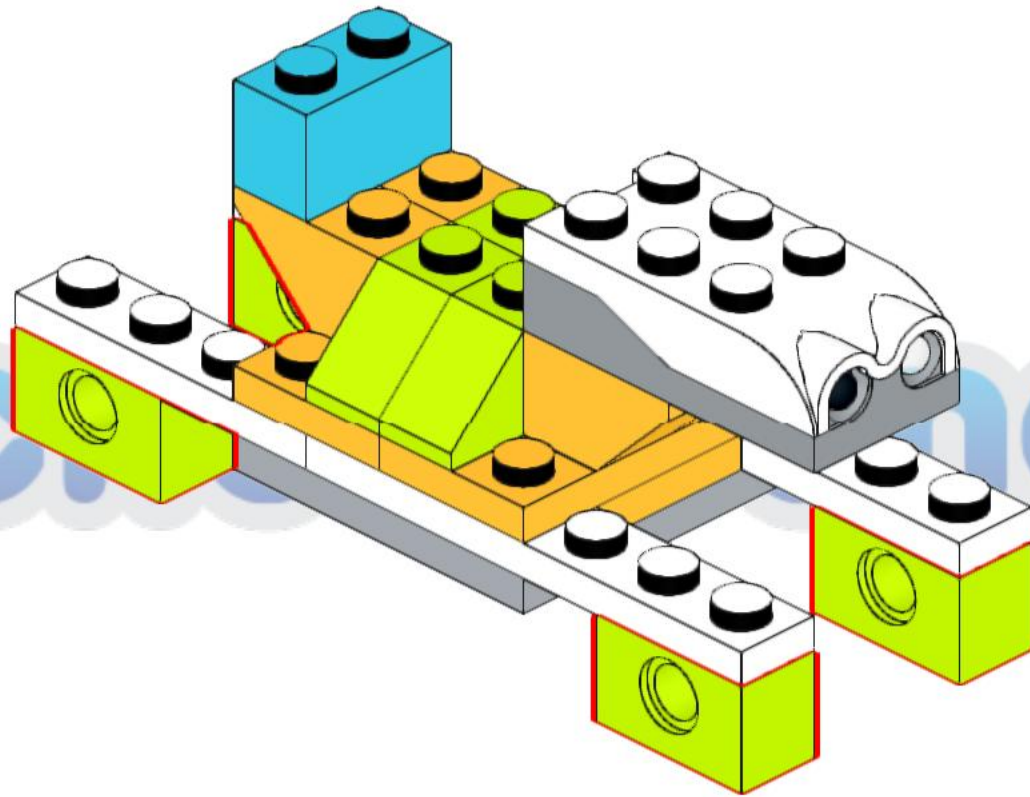
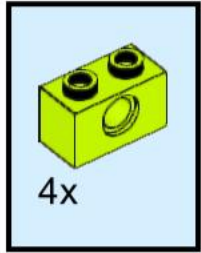

10

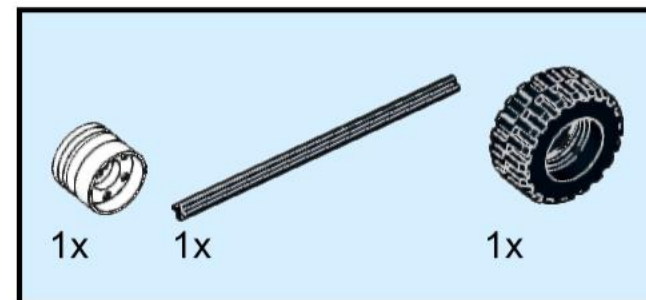
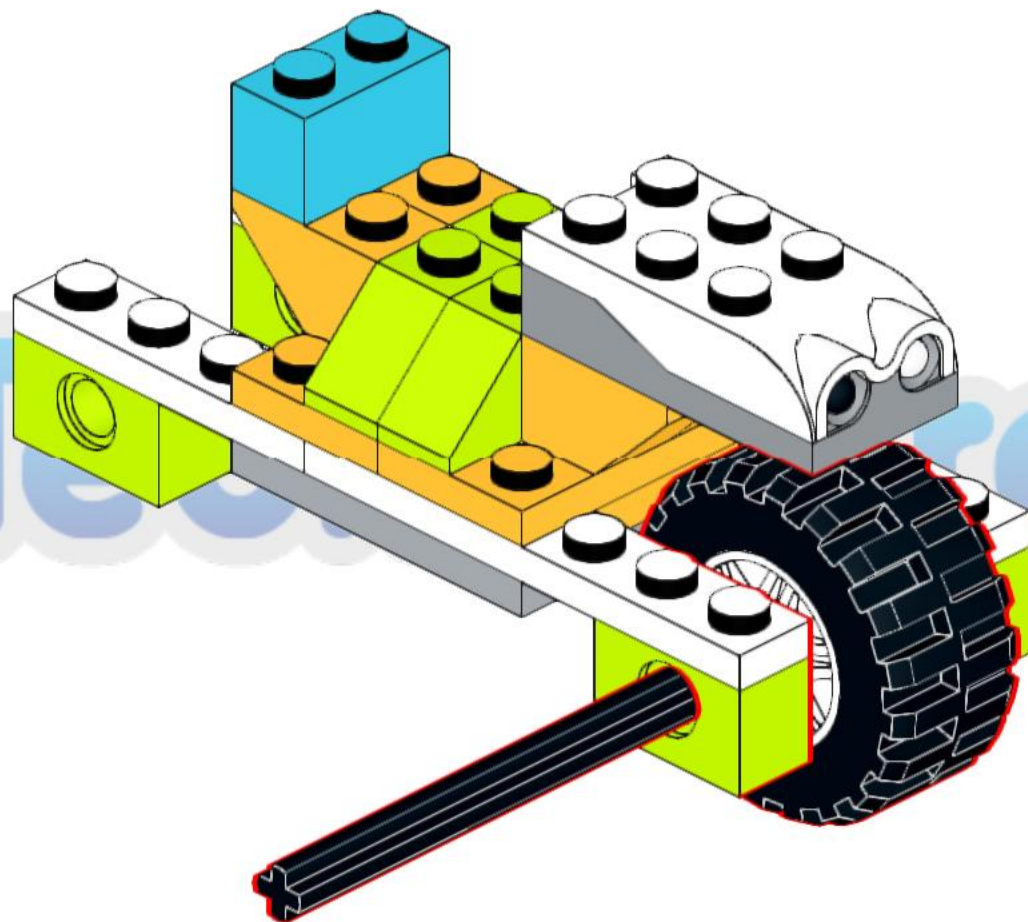

11

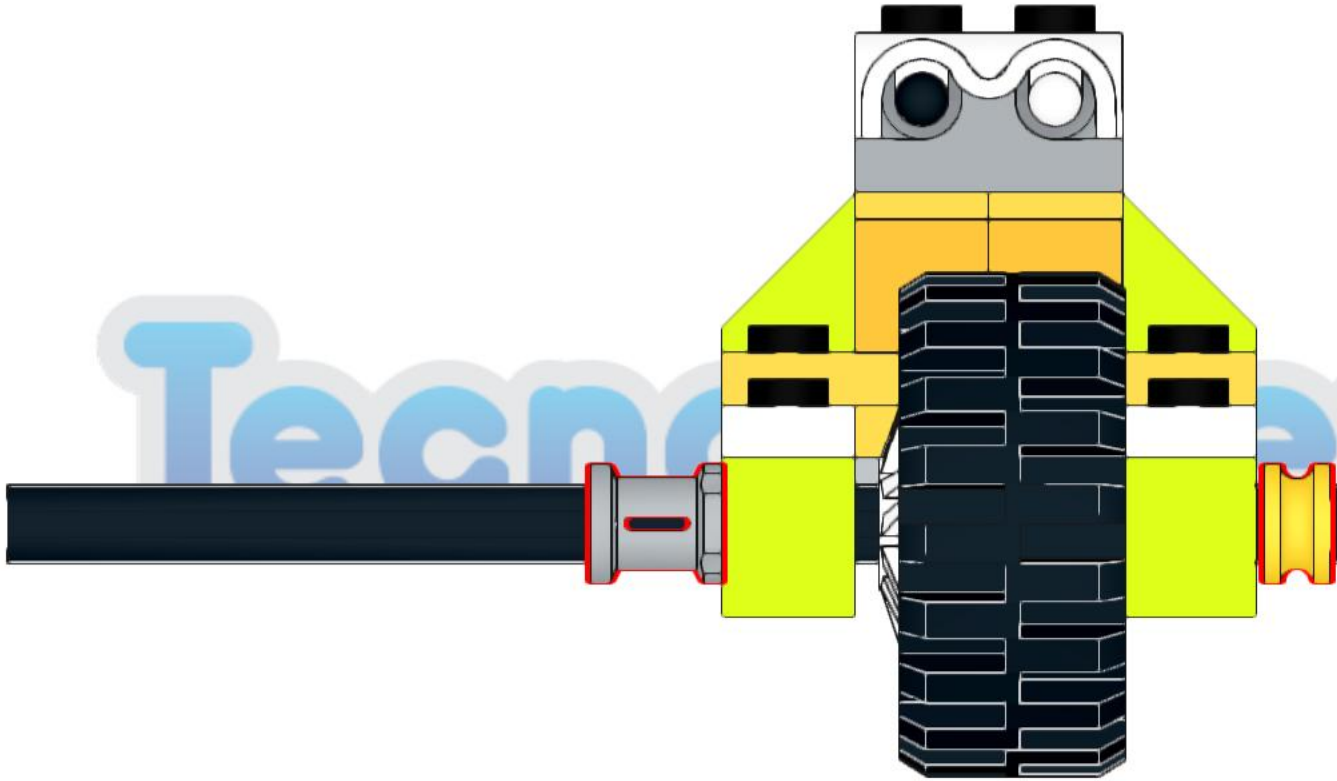
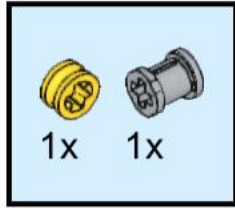

12

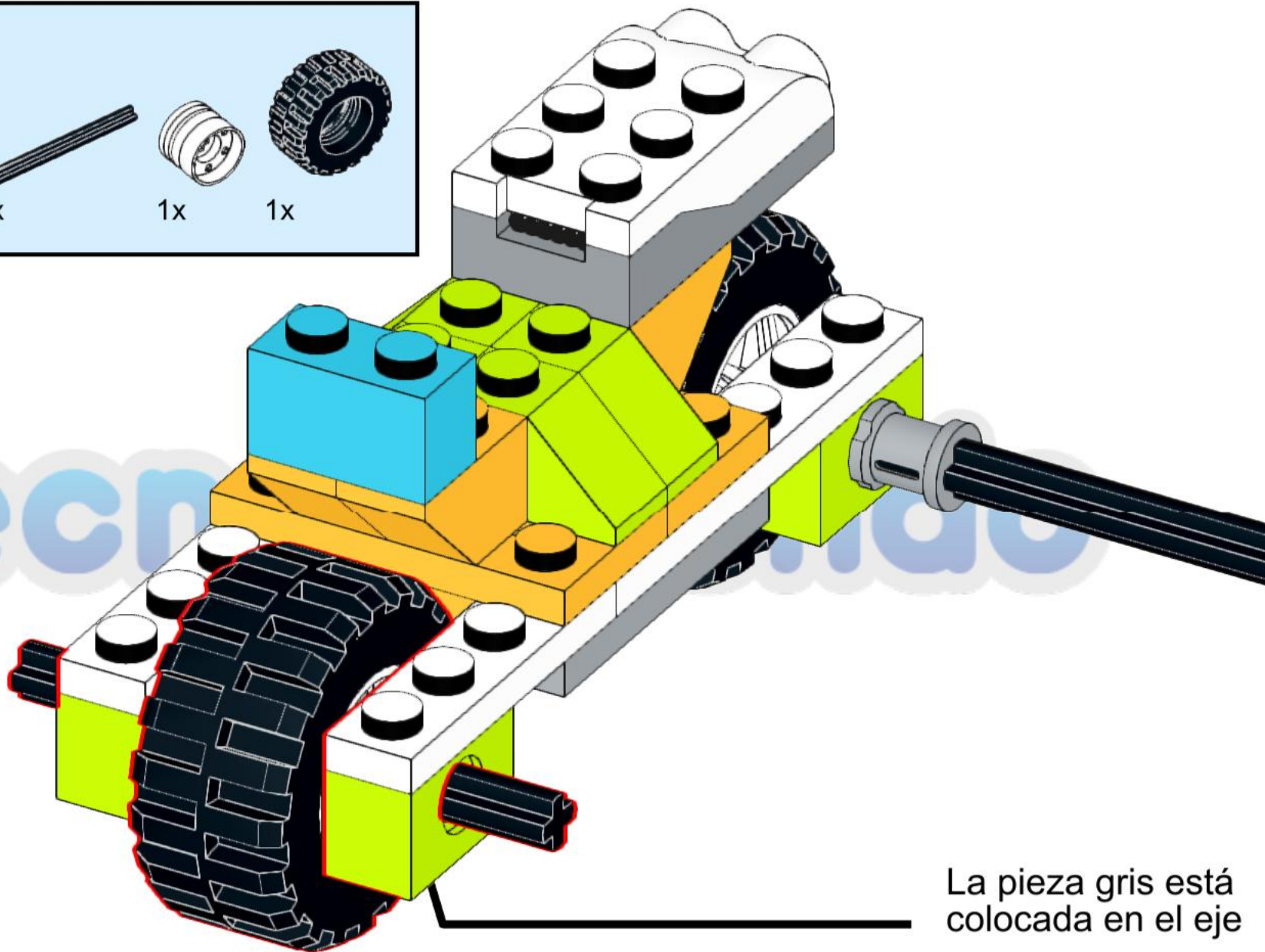
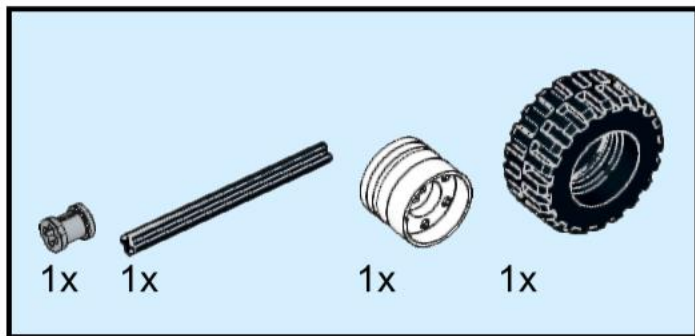

La pieza gris está colocada en el eje

13

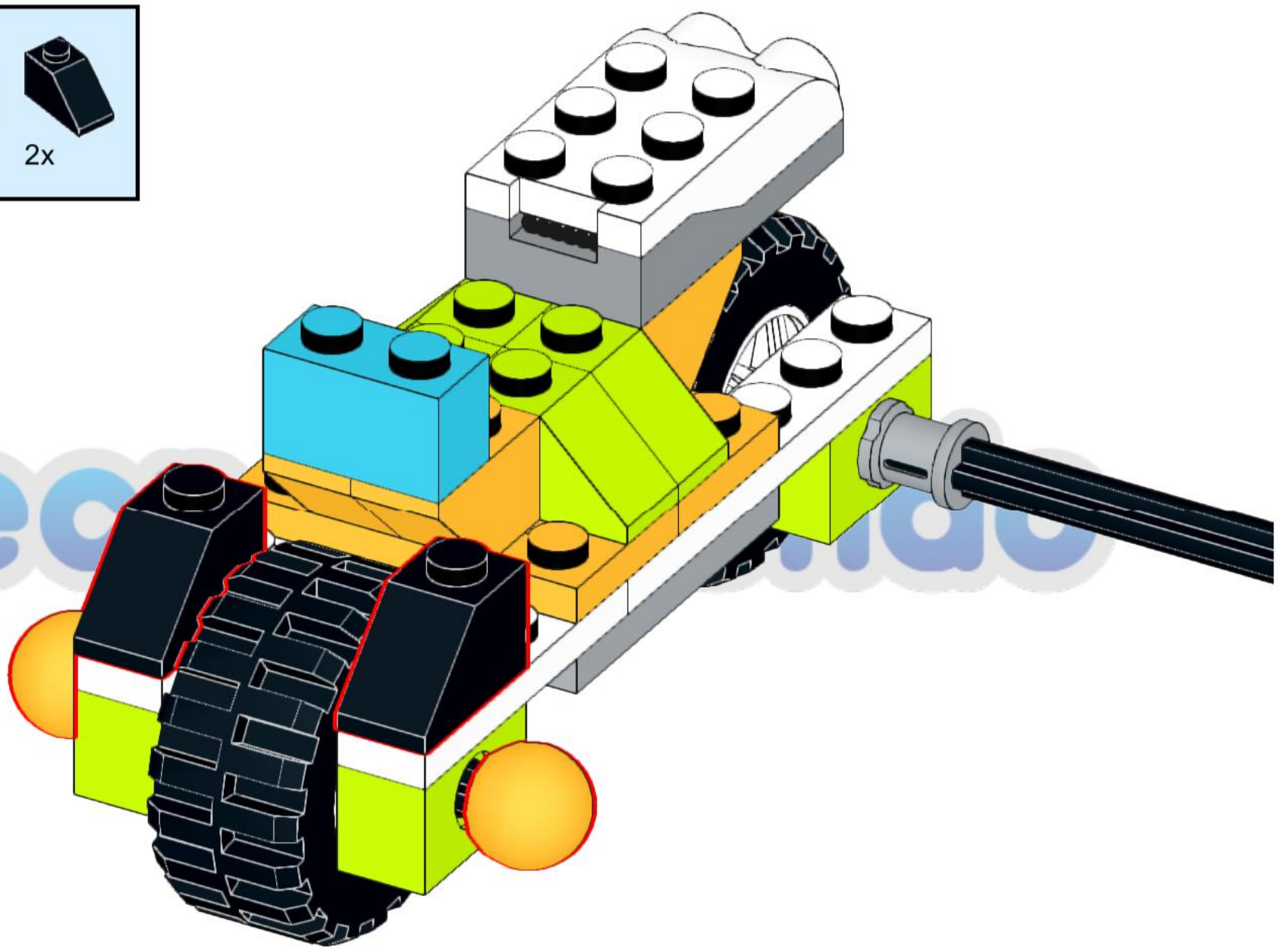
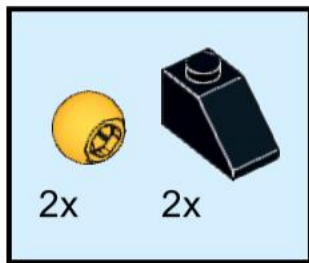

Technic

14

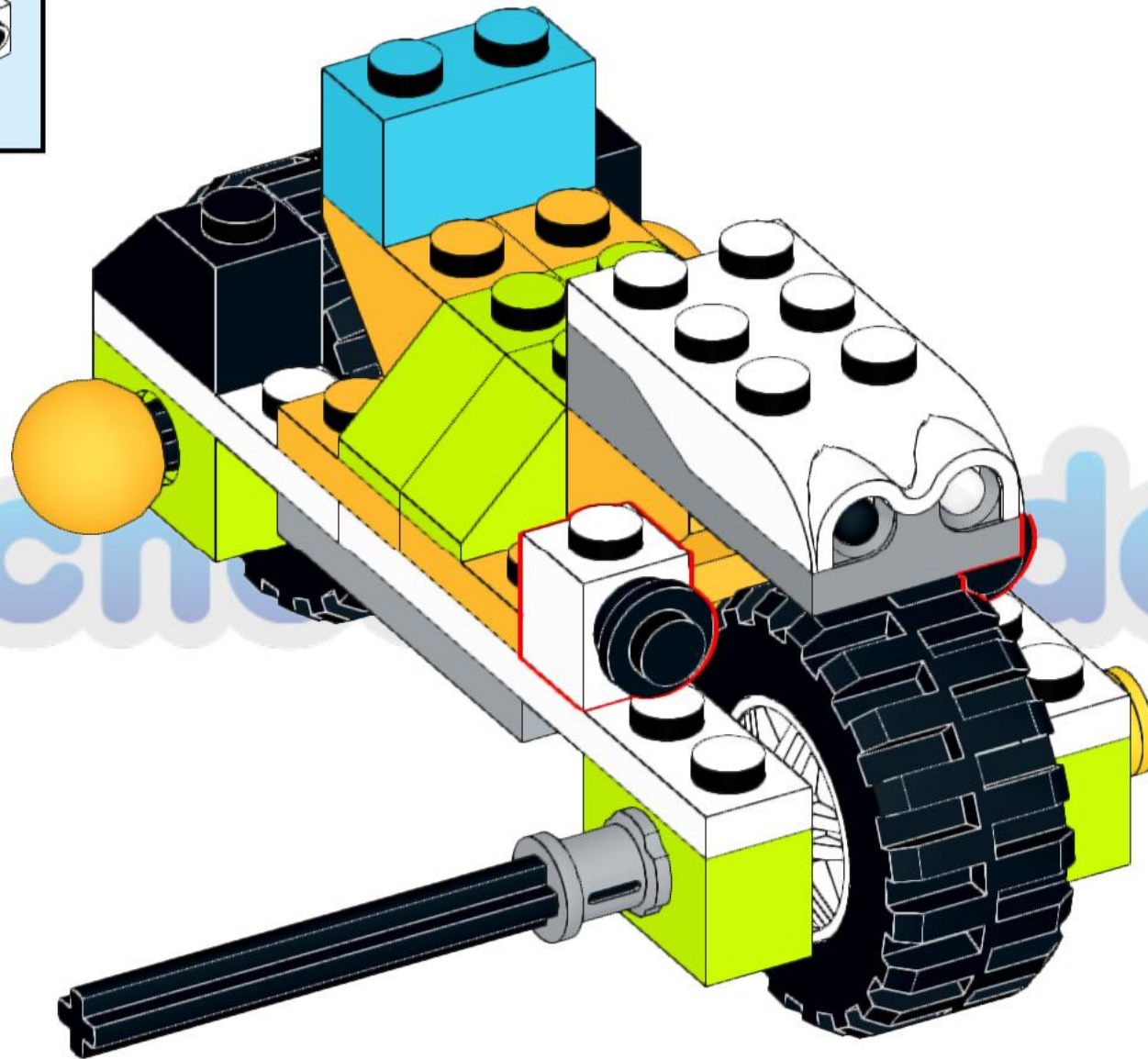
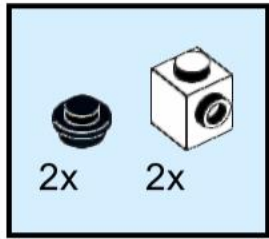

15

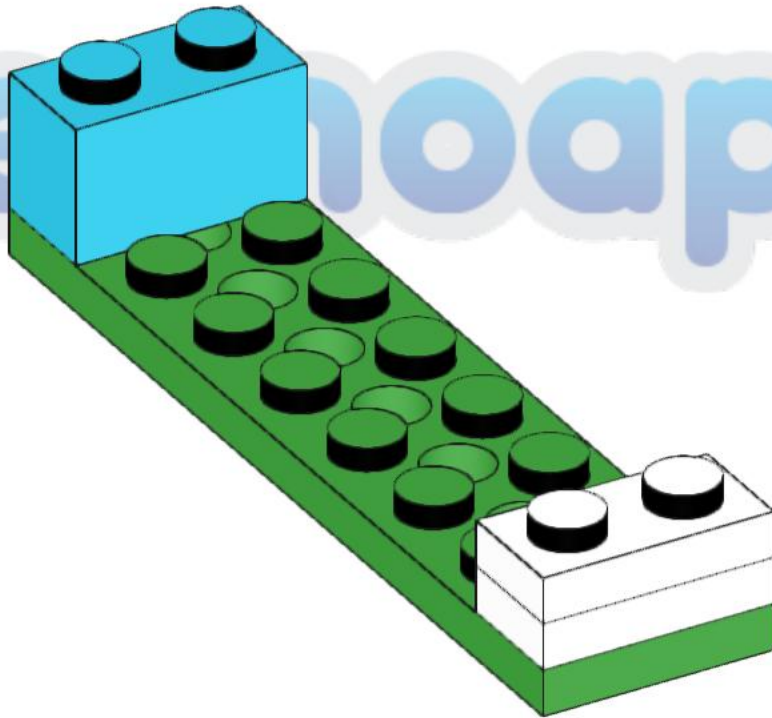
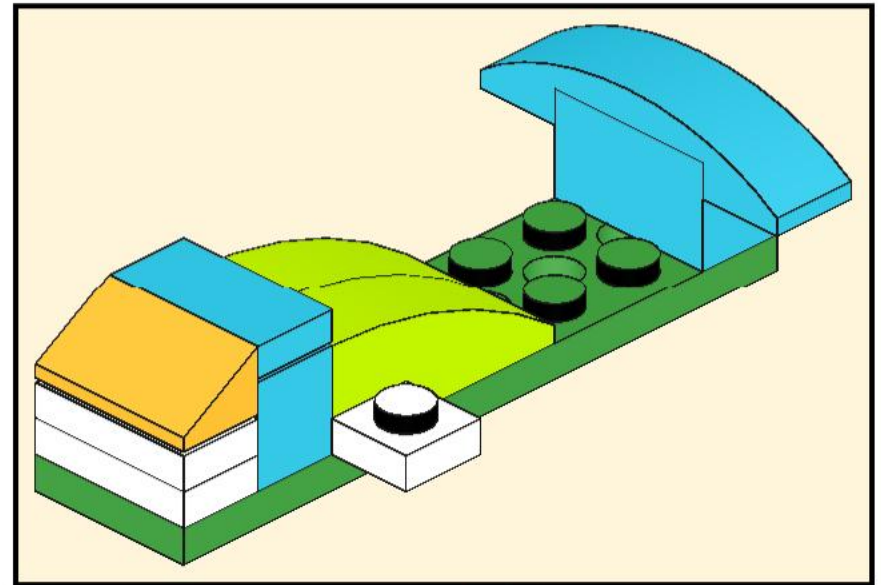
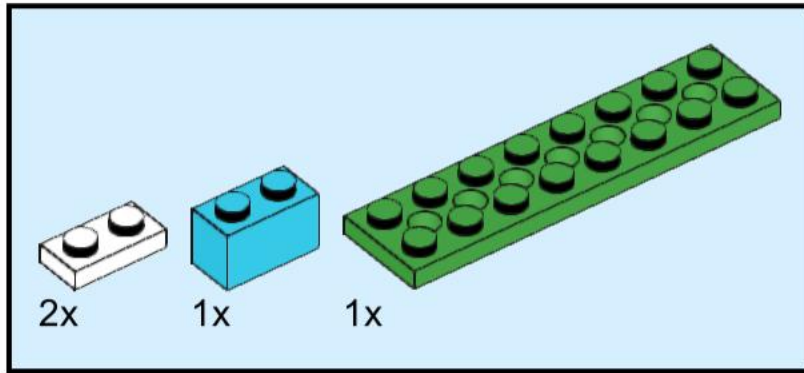

Temoaprendo

16

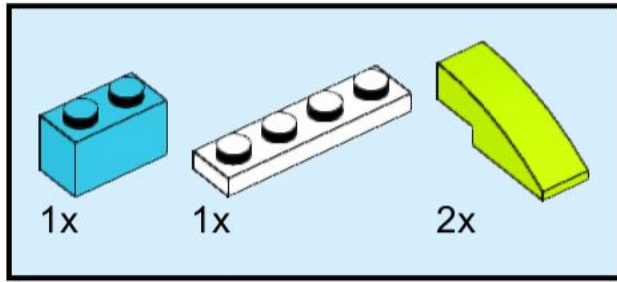

17

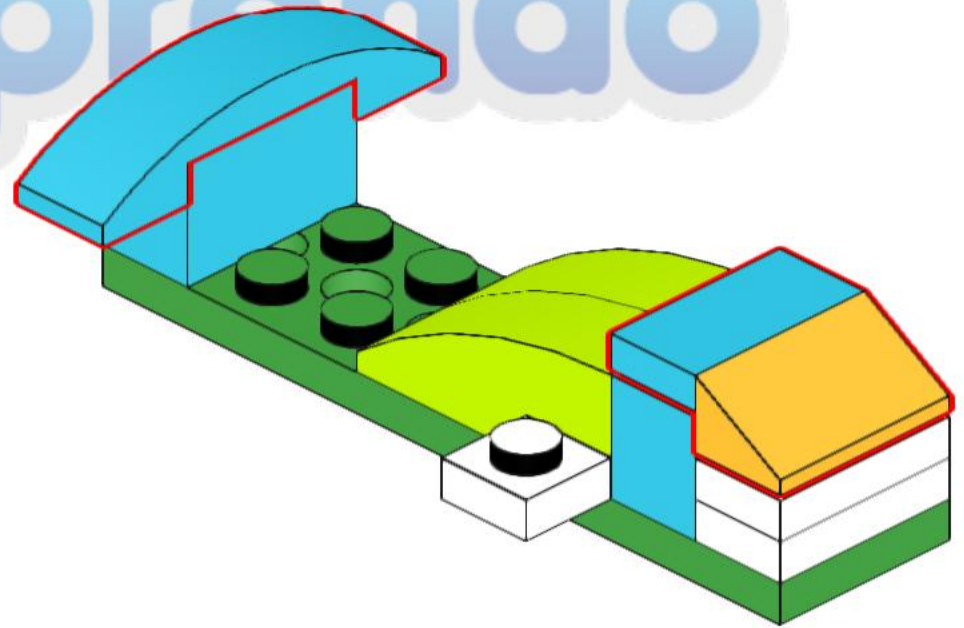
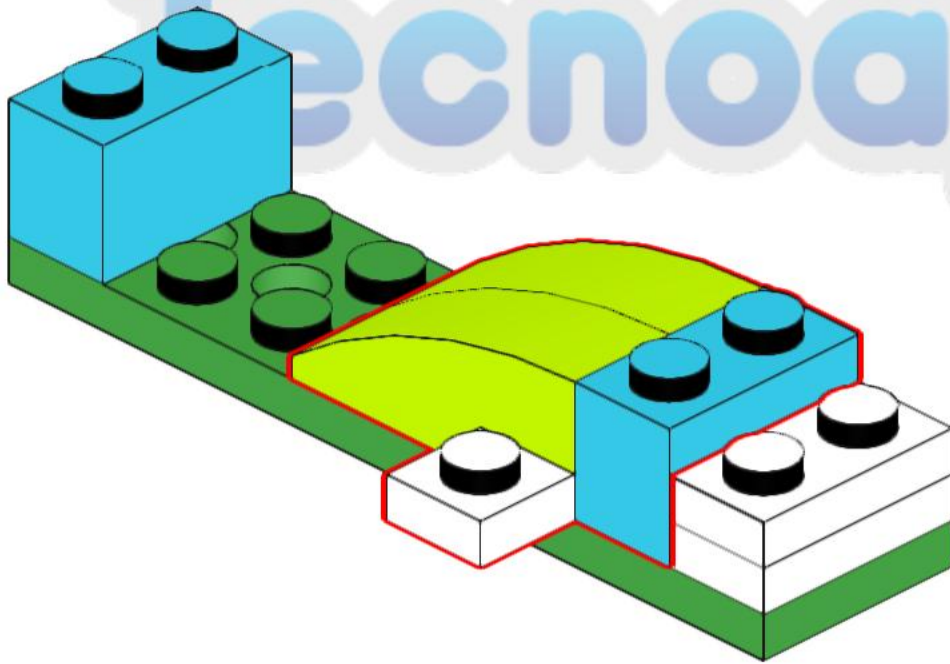
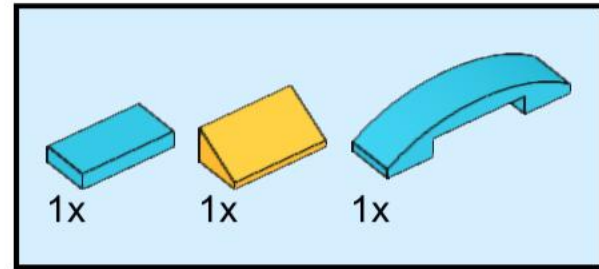

Tecnoaprendo

19

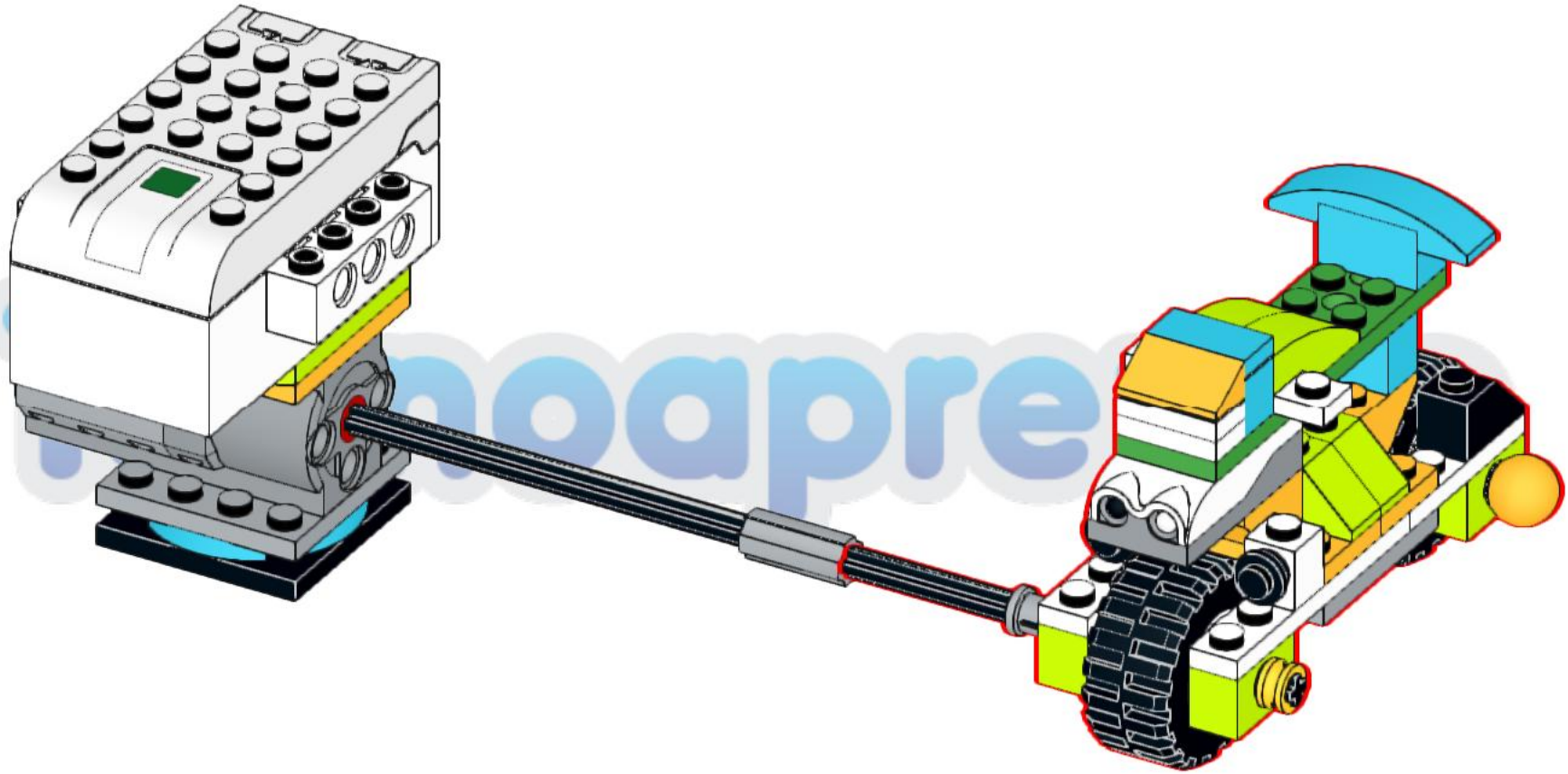

A correr con la moto, pero antes a programar.

1. Intenta poner en marcha la moto, que se pare cuando detecte un obstáculo y que reanude la marcha cuando ya no haya obstáculo delante.

2. La moto debe de detectar a qué distancia está el sensor del obstáculo y acelerar dependiendo de esa distancia.

Ejemplo: si el obstáculo está a distancia 0, el motor se para. Si el obstáculo está a distancia uno, el motor va a velocidad 1, y así sucesivamente.

Tecnoaprendo





1.



2.



2x
4073, 11



2x
3040, 11



2x
92402, 11



1x
61485, 11



1x
3706, 11



2x
3737, 11



2x
3713, 86



1x
6538c, 86

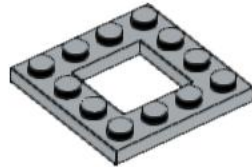

2x
64799, 86

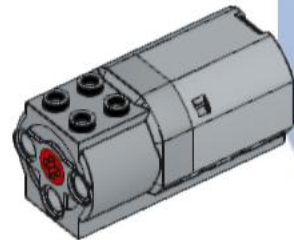

1x
21980, 86



2x
87087, 1



2x
3023, 1



2x
55982, 1

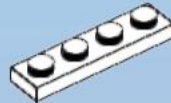

3x
3710, 1



1x
20844, 1

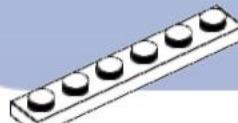

2x
3666, 1

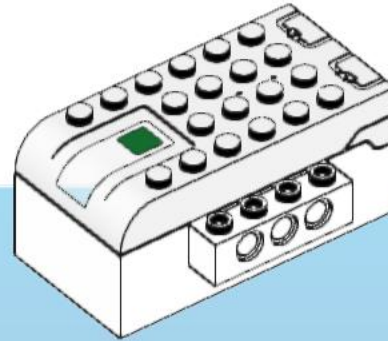

1x
19071c01, 1



2x
32474, 110



1x
85984, 110



4x
3665, 110

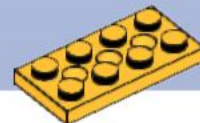

4x
3709b, 110



1x
4265c, 3



4x
3040, 34



4x
3700, 34

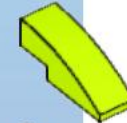

2x
50950, 34

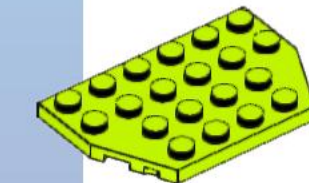

1x
32059, 34

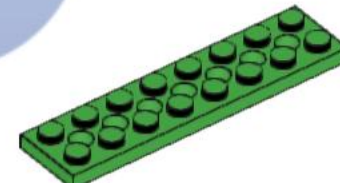

1x
3738, 36

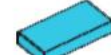

1x
3069b, 156

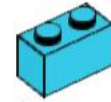

3x
3004, 156

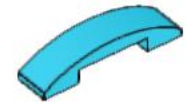

1x
93273, 156



1x
60474, 156