

More buildings from Anger project  
on <https://play.google.com/store/apps/developer?id=AnGer+project>

AnGer  project

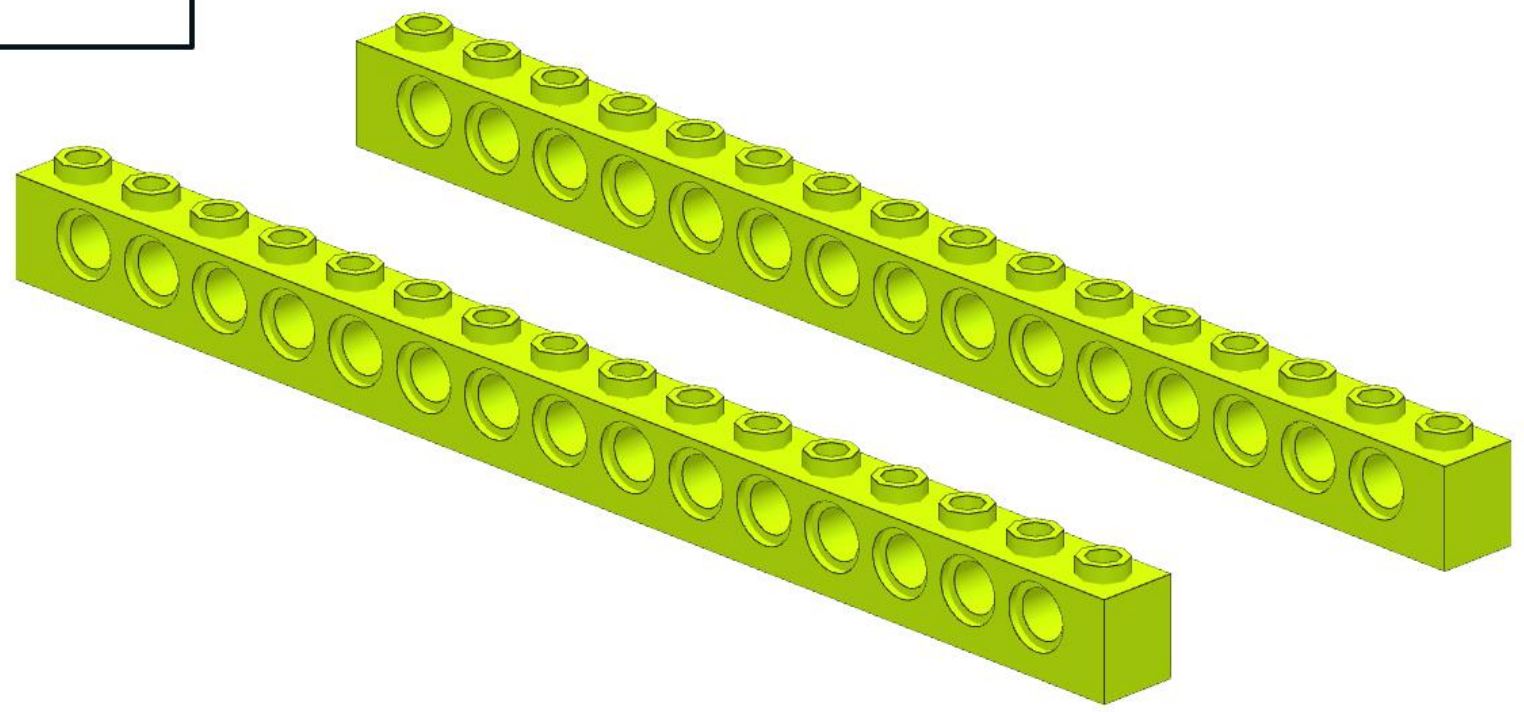

1

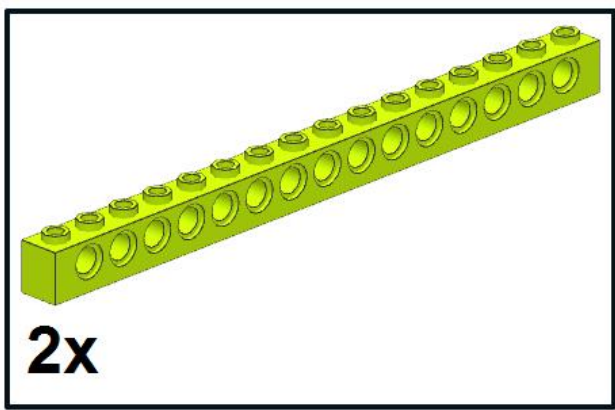

2

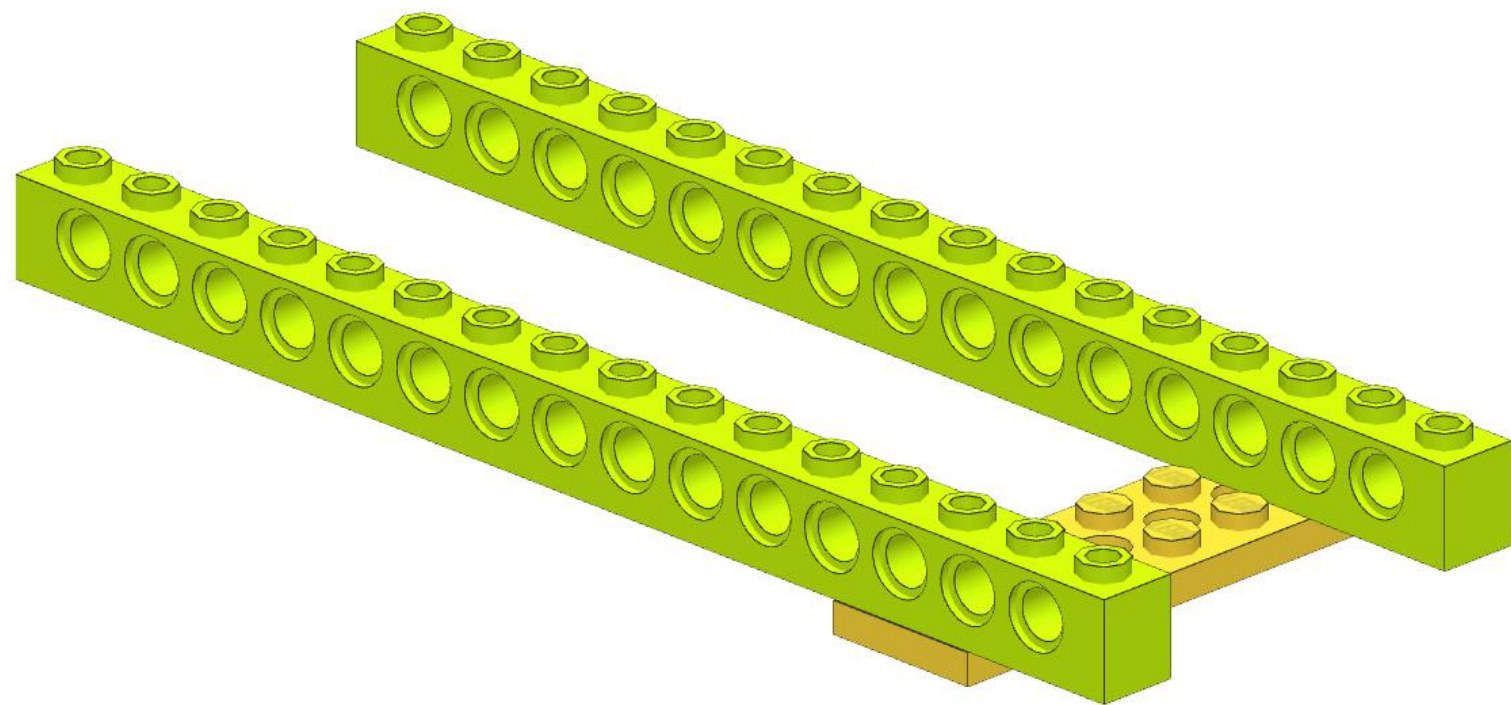
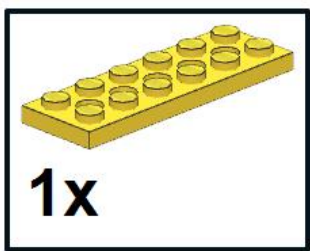

3

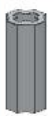

1x 2x4

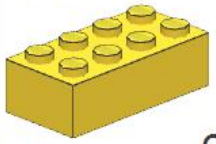

1x

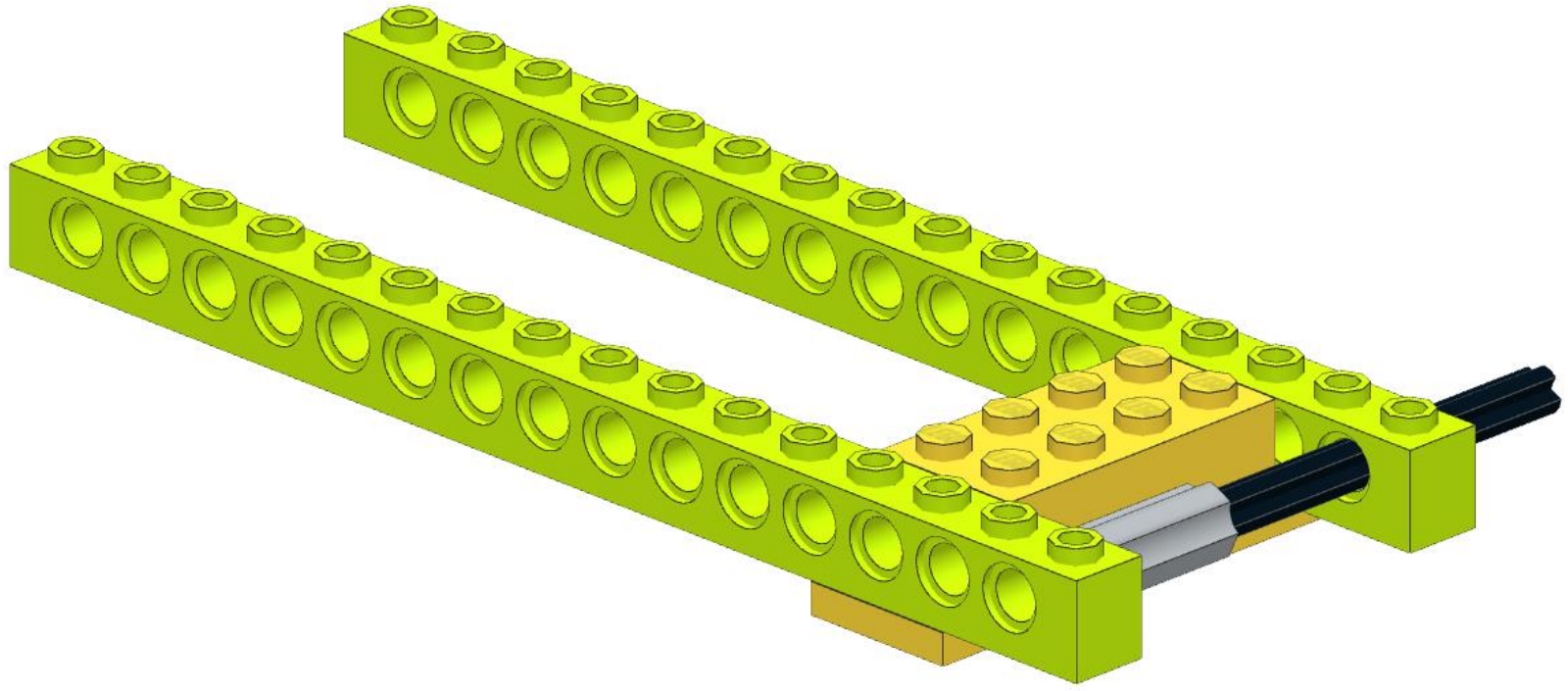

4

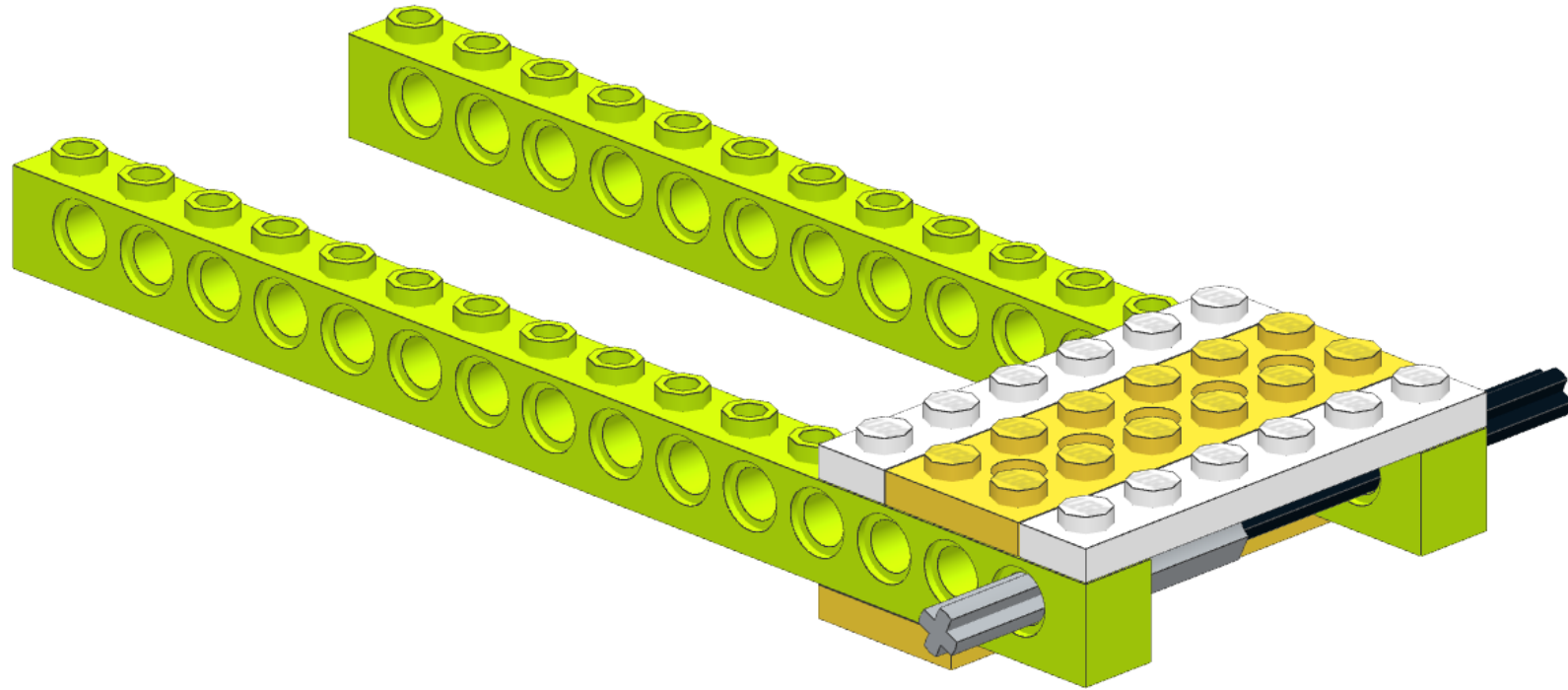
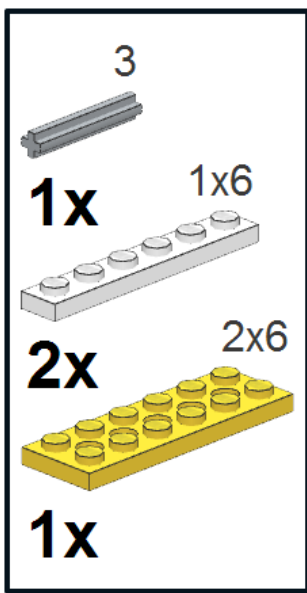

5

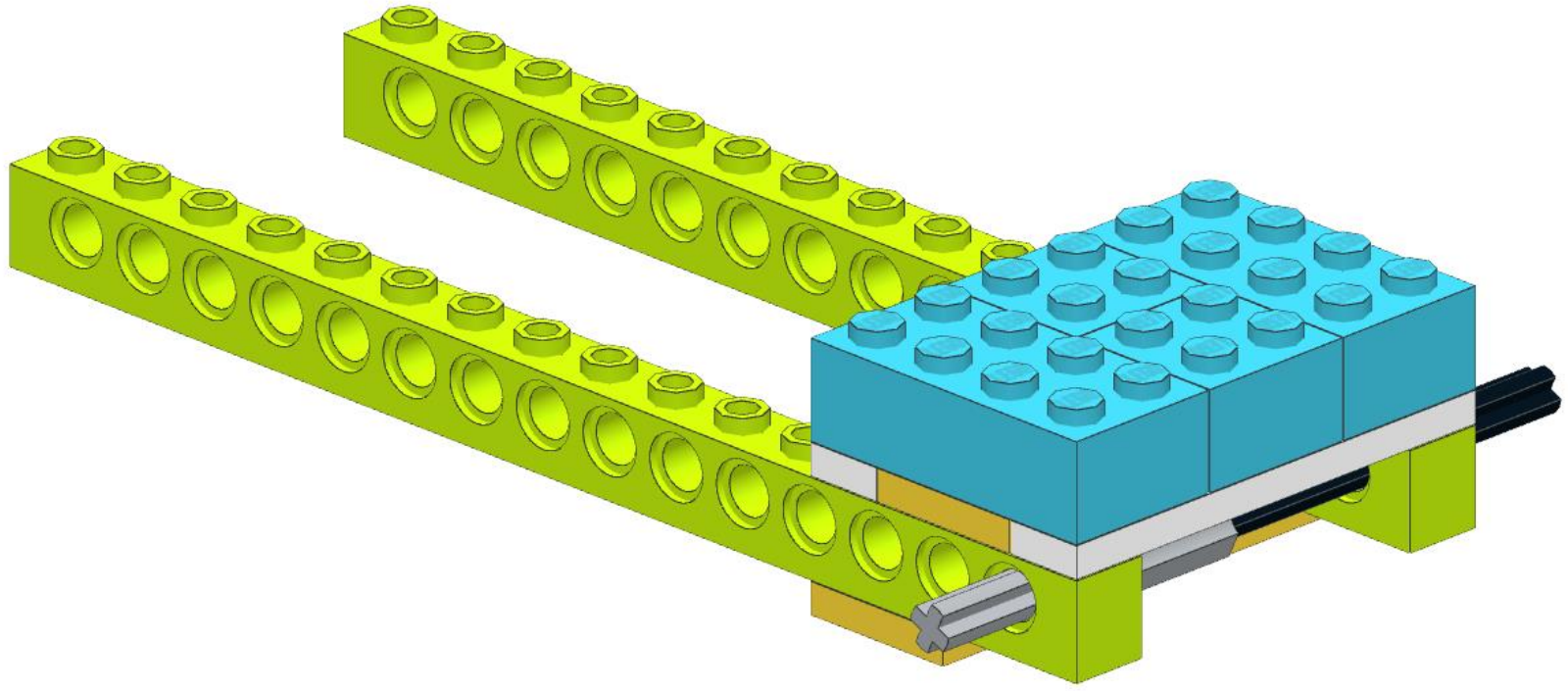
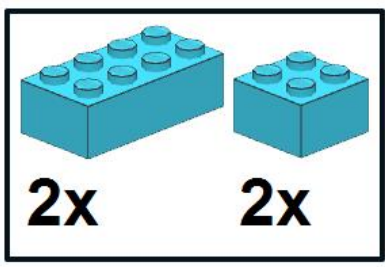

6

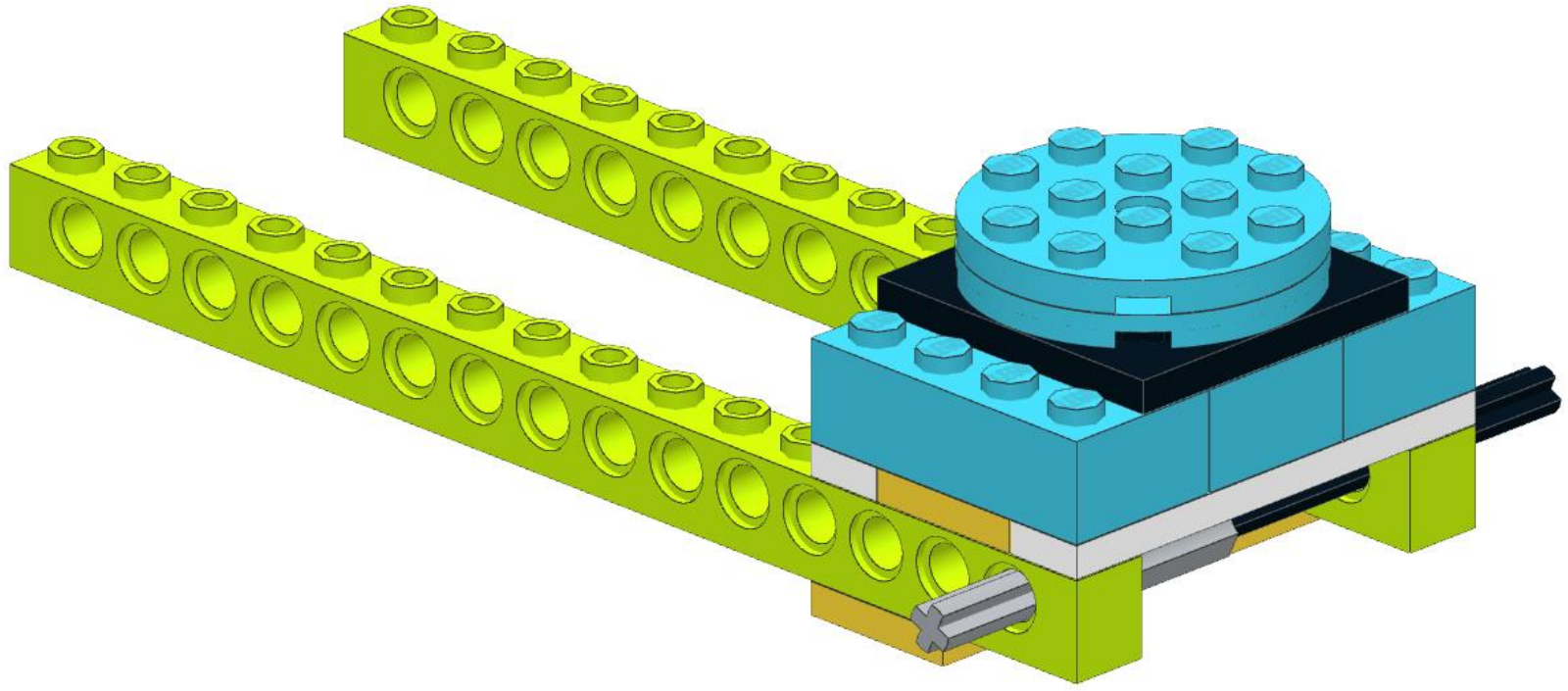
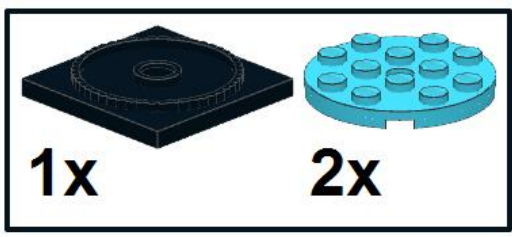

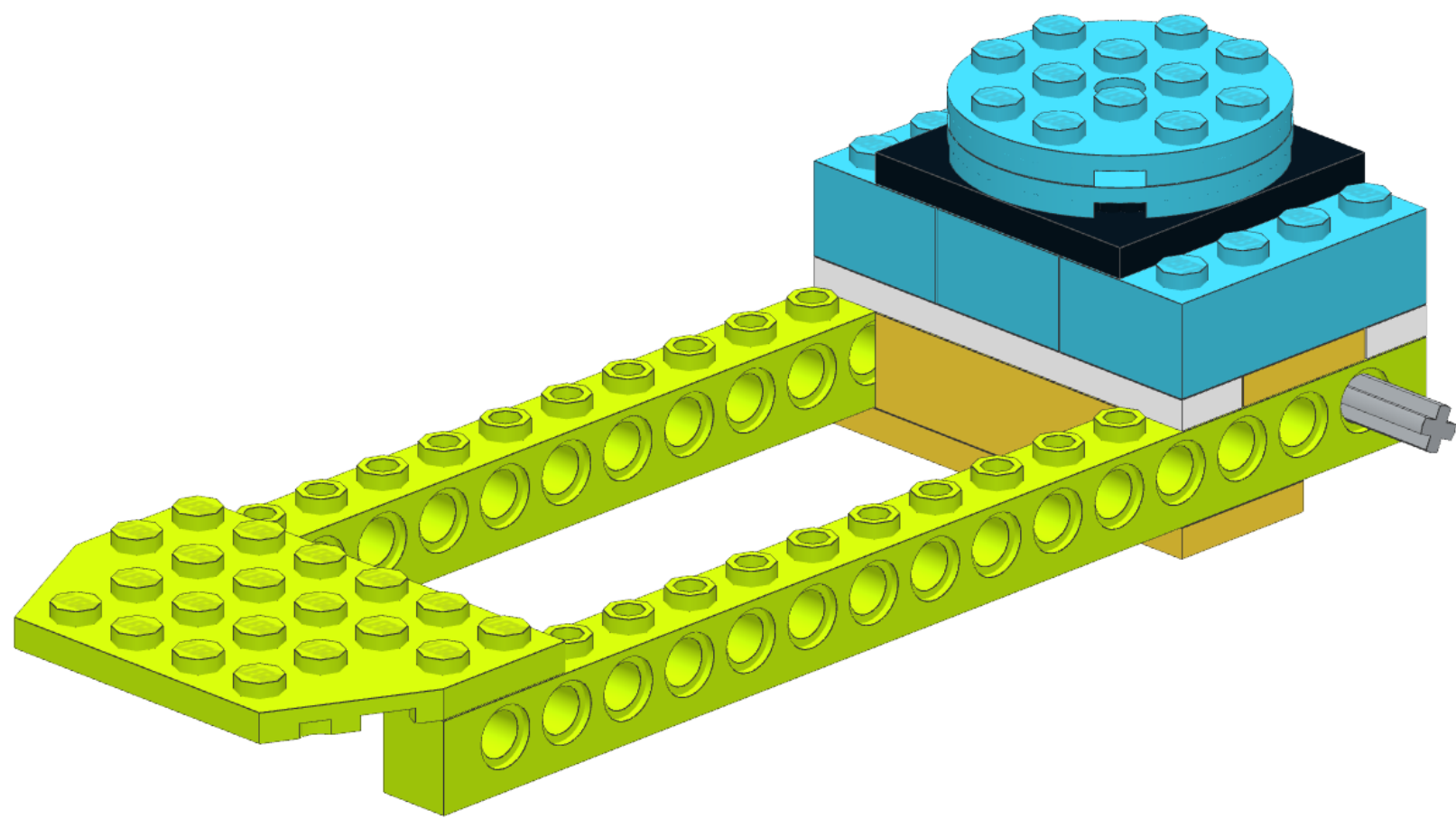
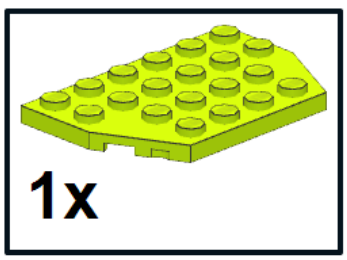

7



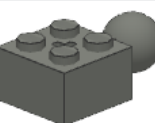
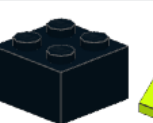

8

		
1x	3x	2x

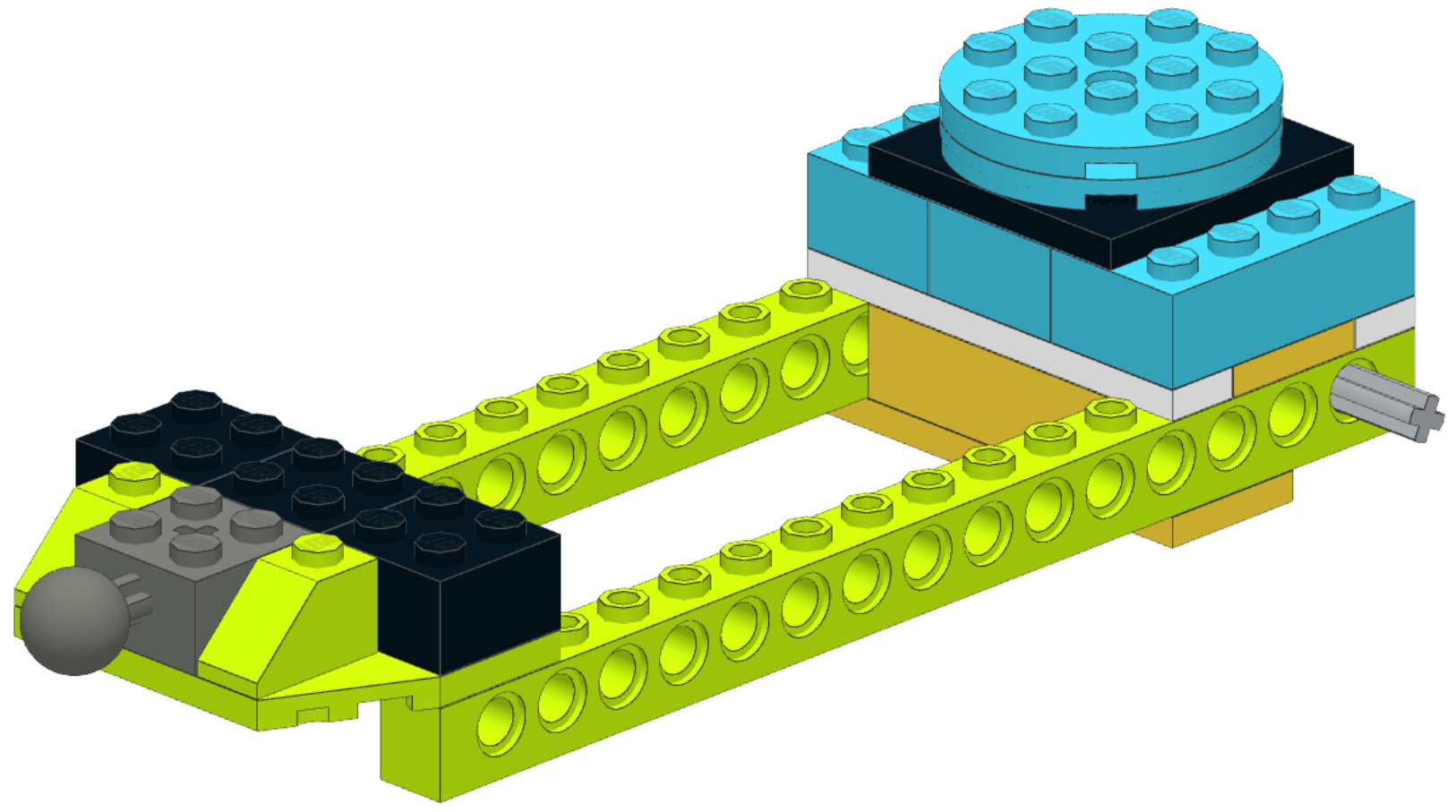

9

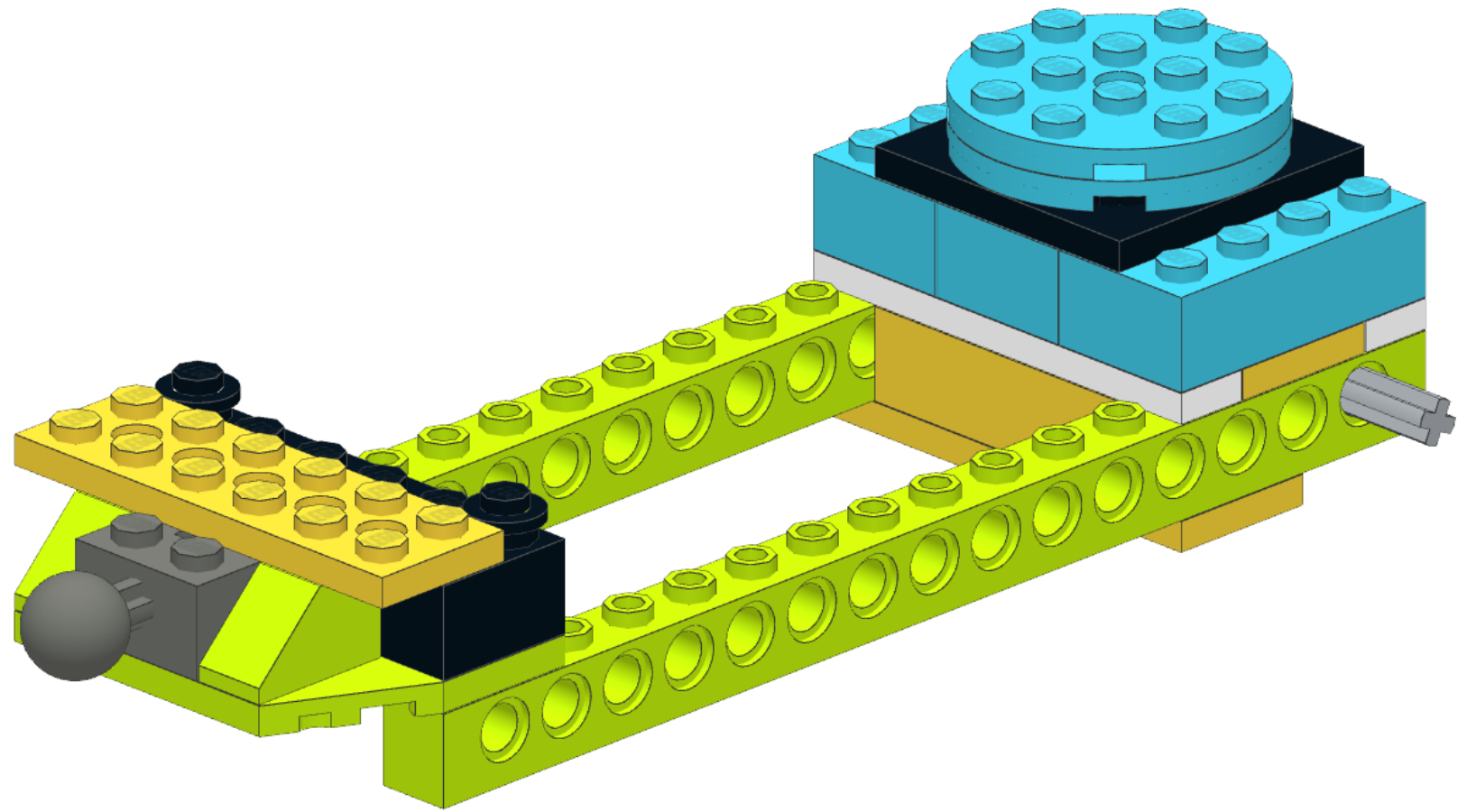
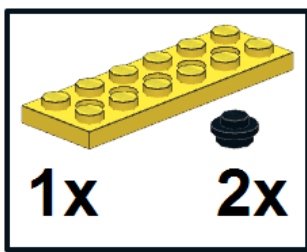

10  2x

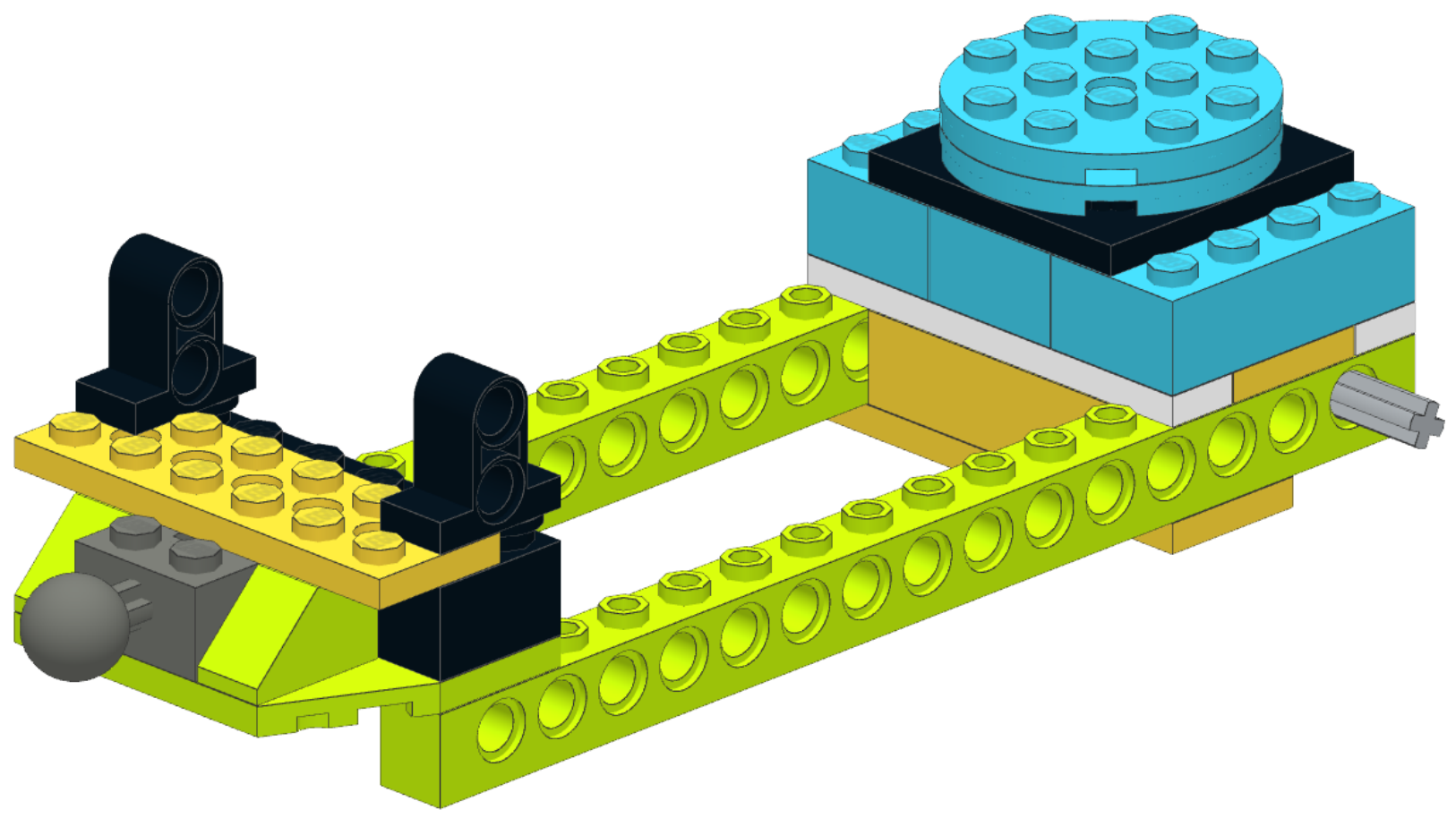

11  4x

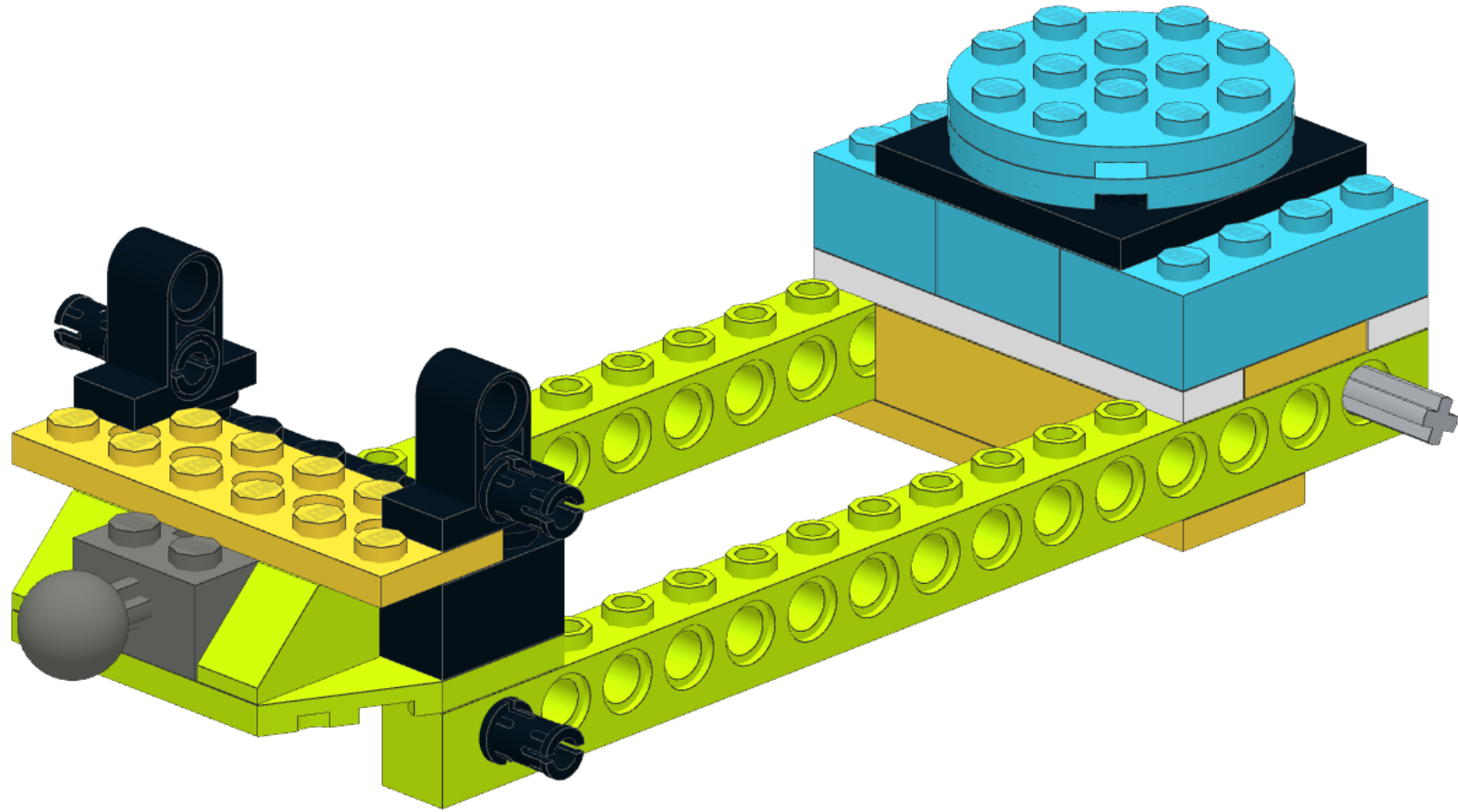

12

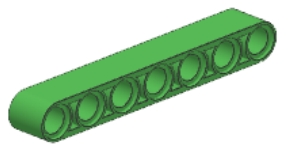

2x

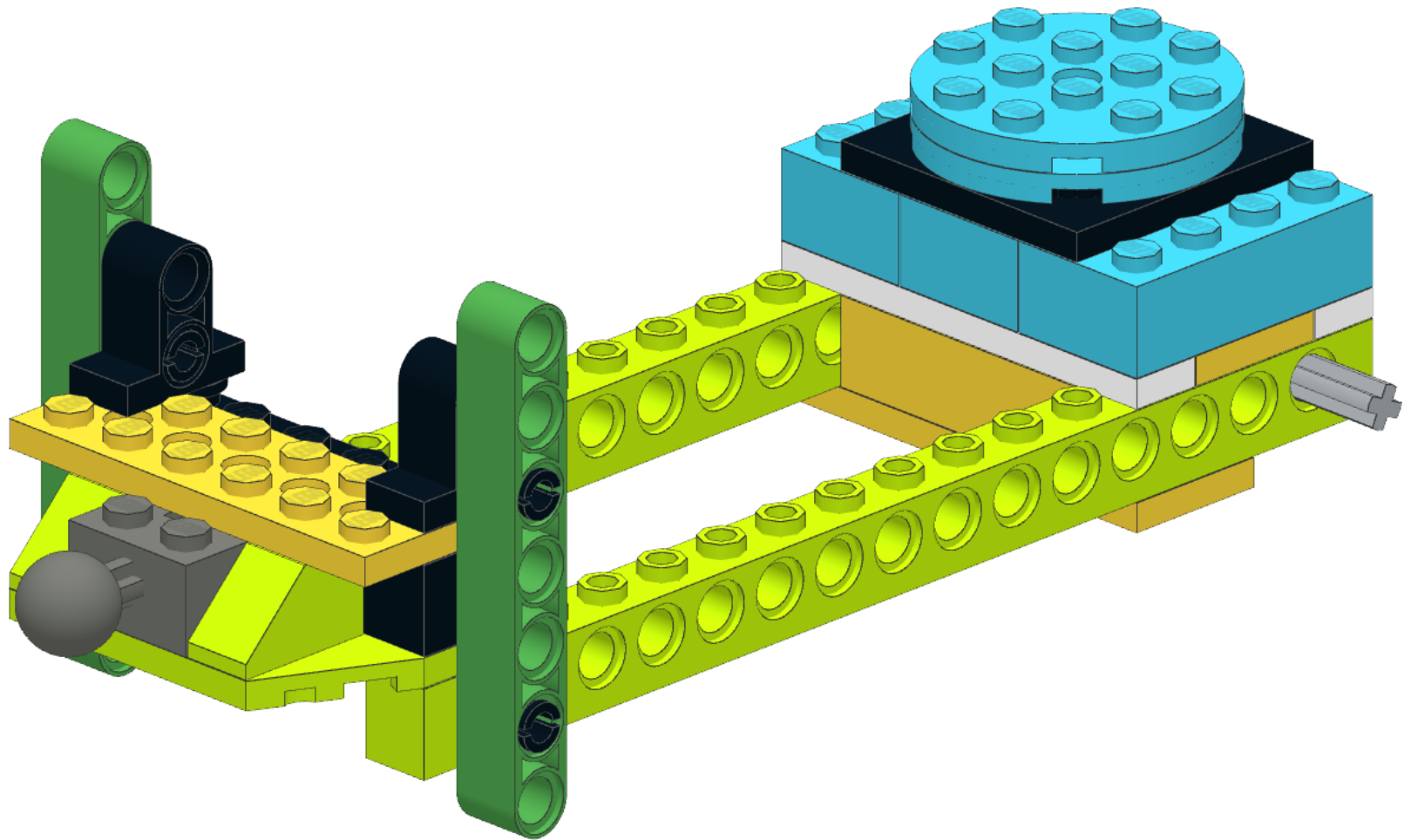

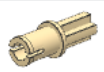
13  2x

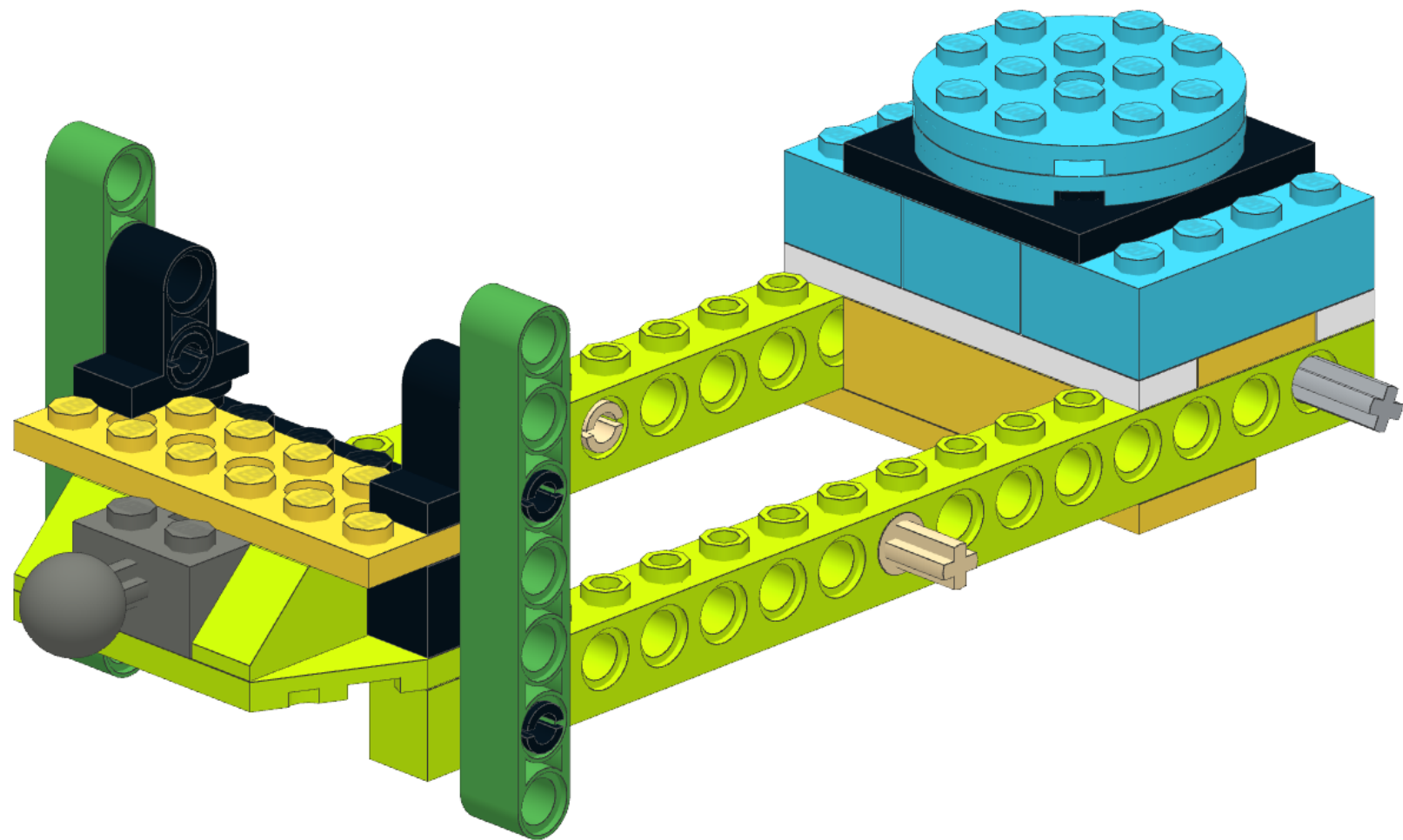

14

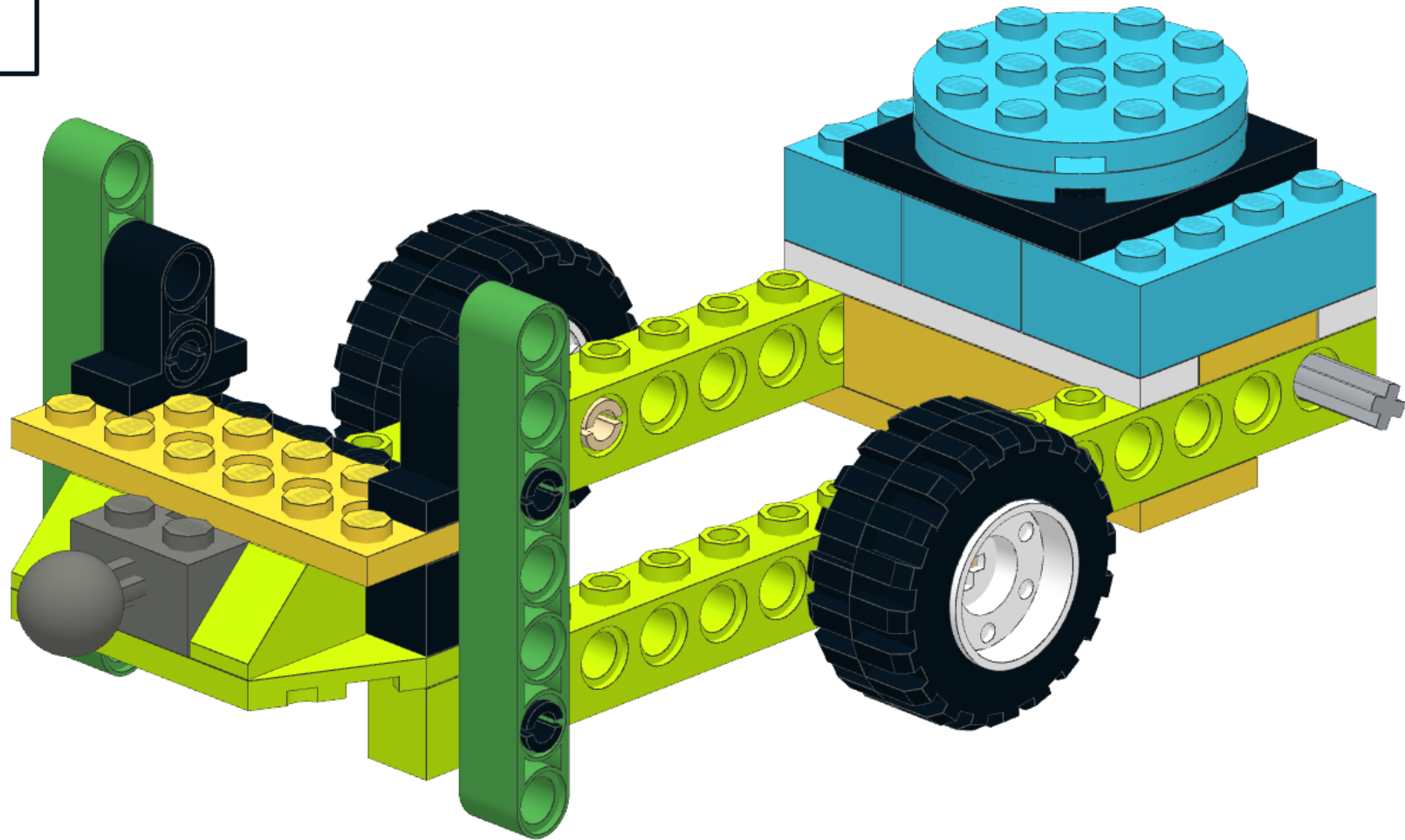
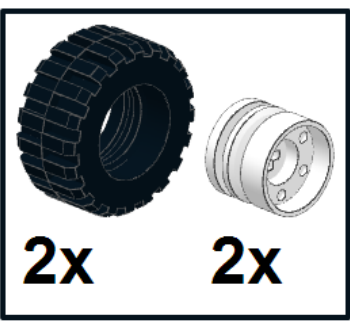

15

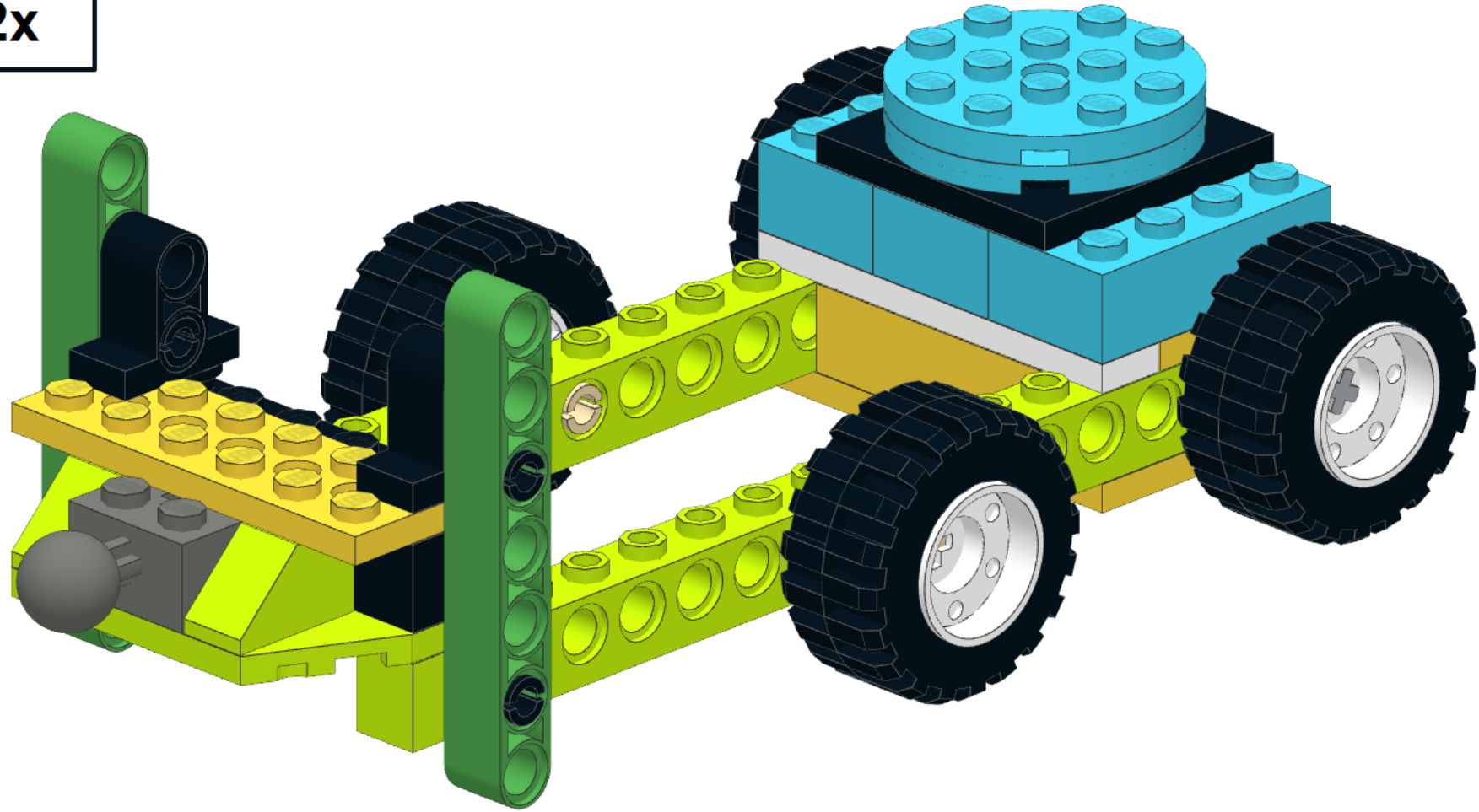
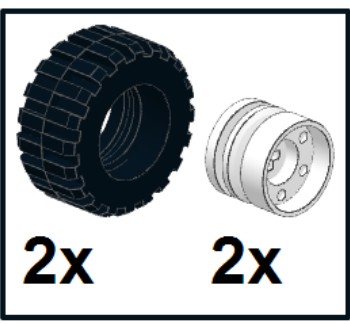



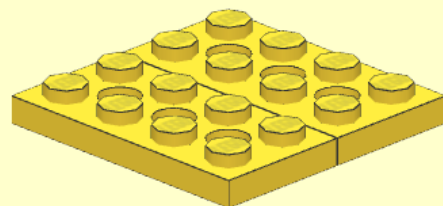
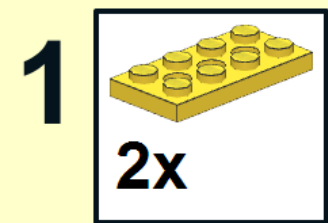

1

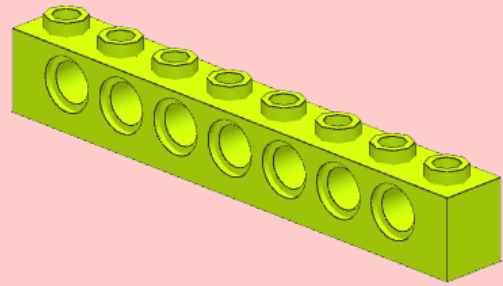
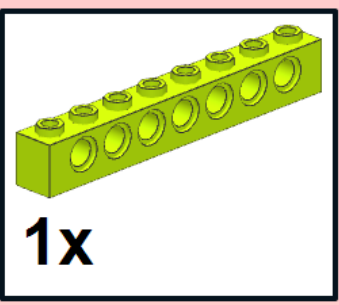

2  3x

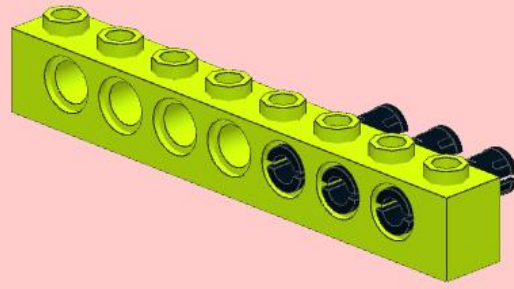

3

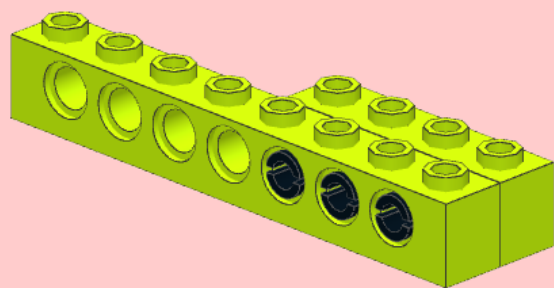
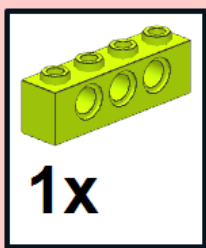

2

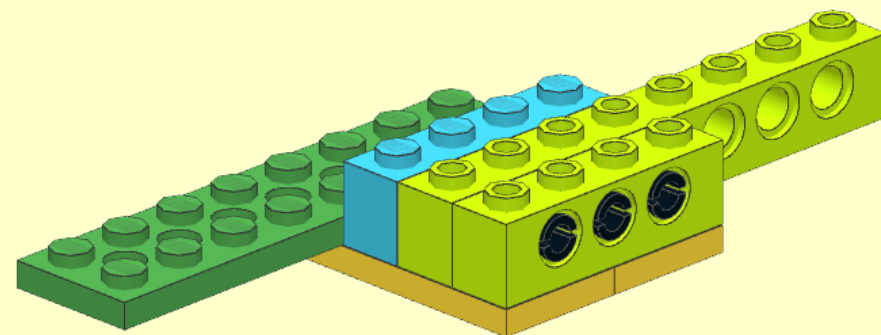
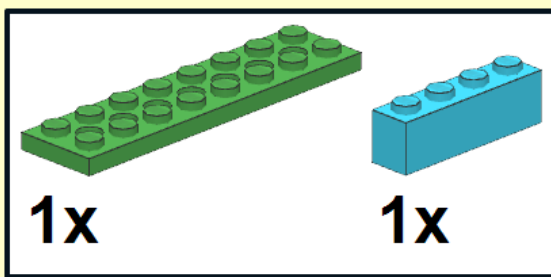

3



1x

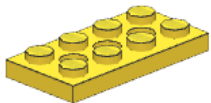

1x

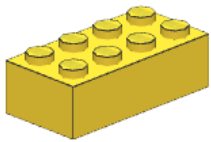

1x

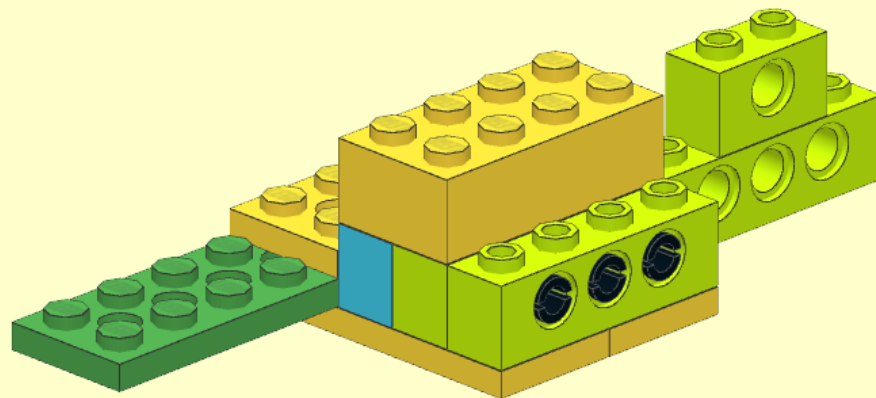

4

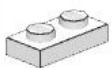

2x



1x

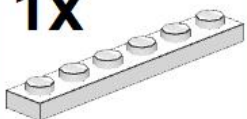

1x

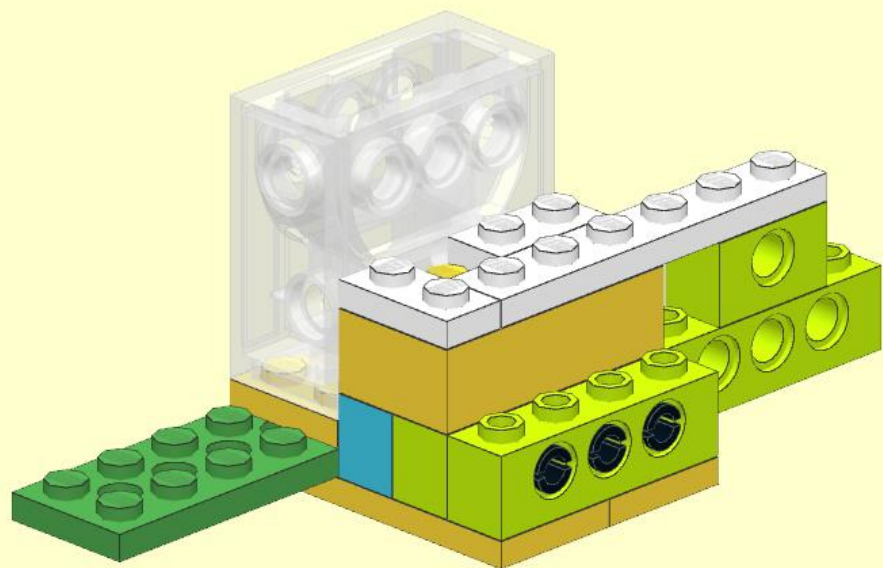

5



1x

6



1x

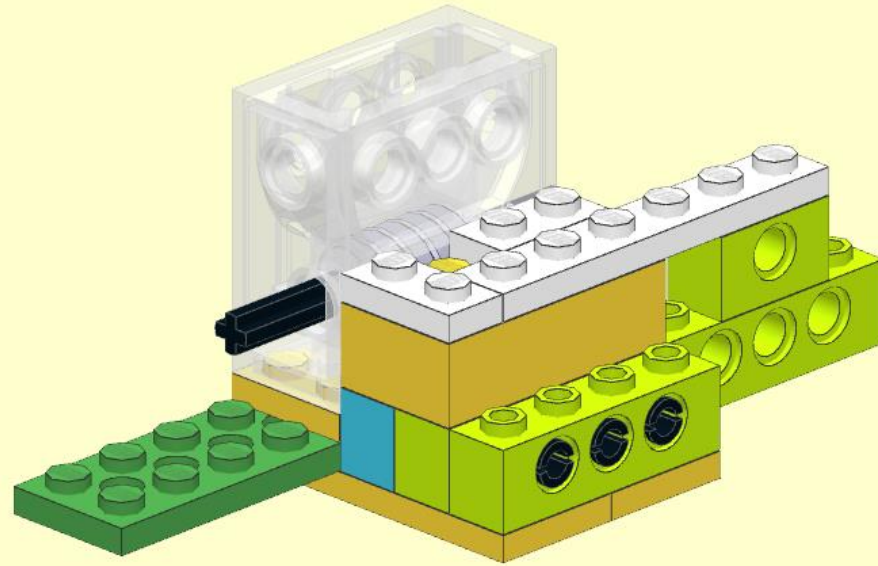



6

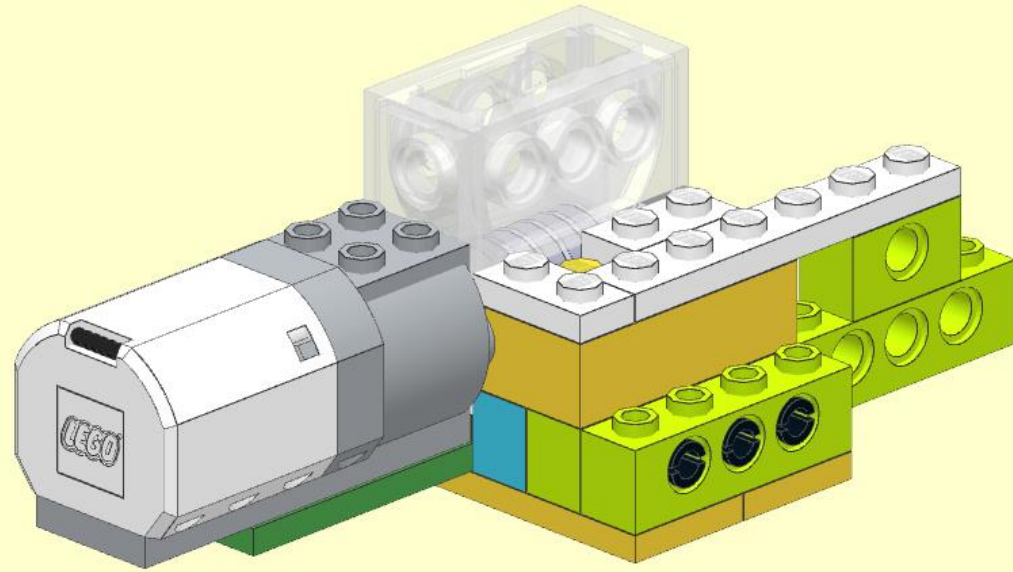

7

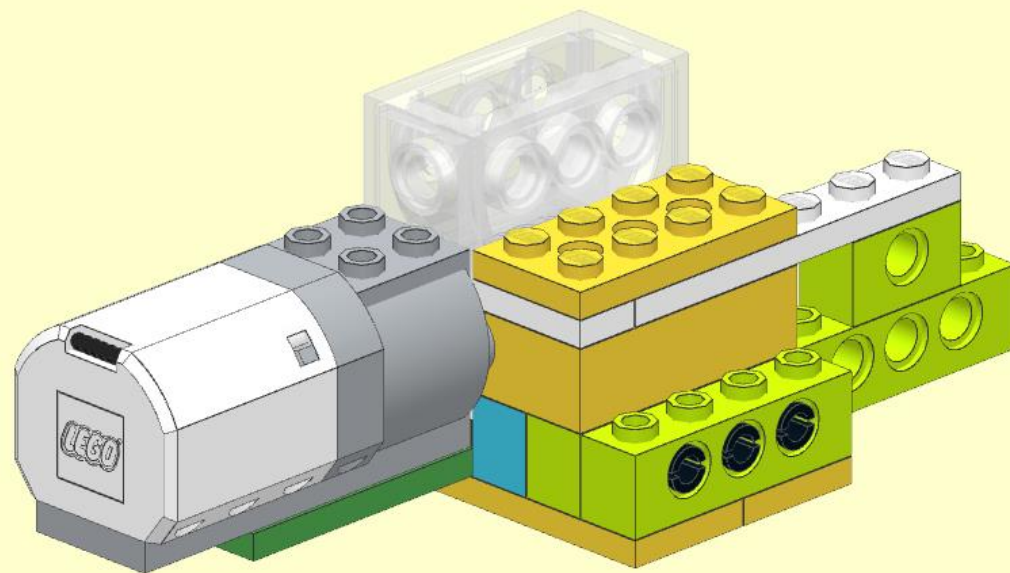
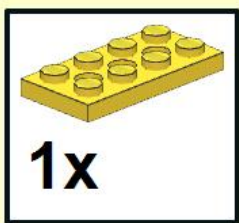

8

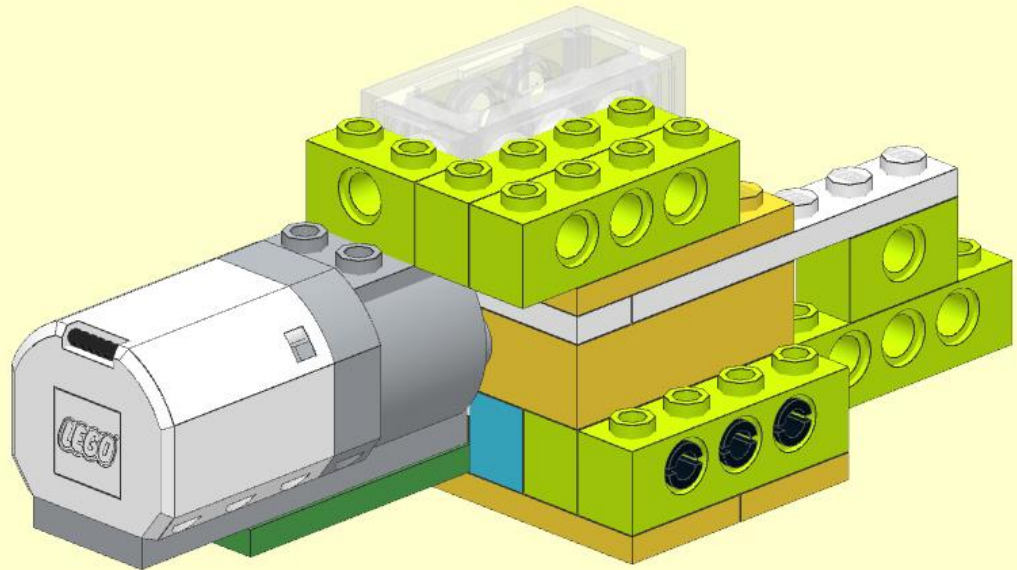
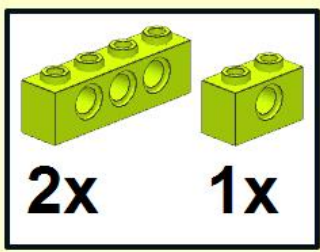

9

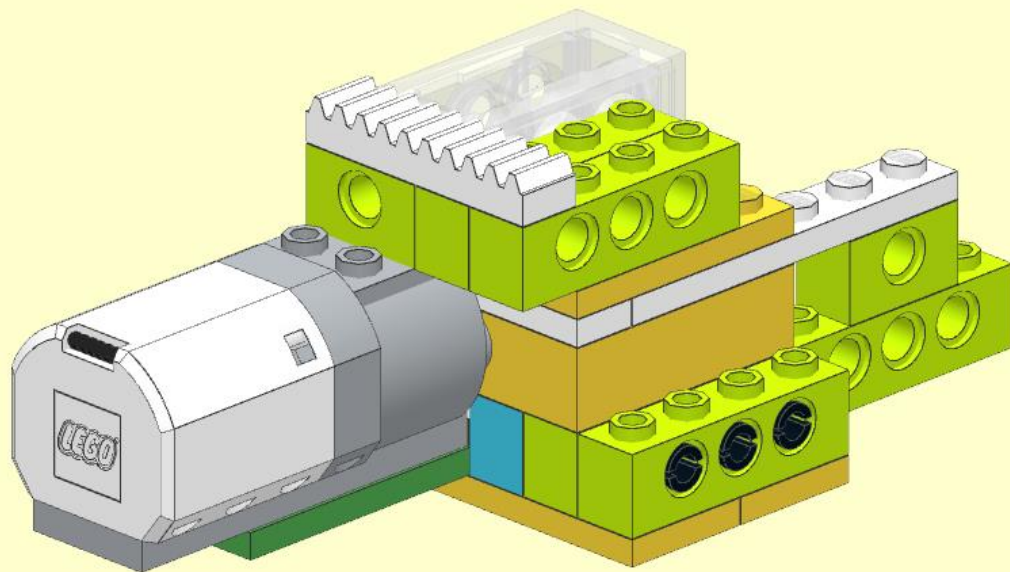
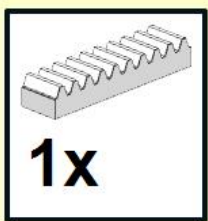

10



1x

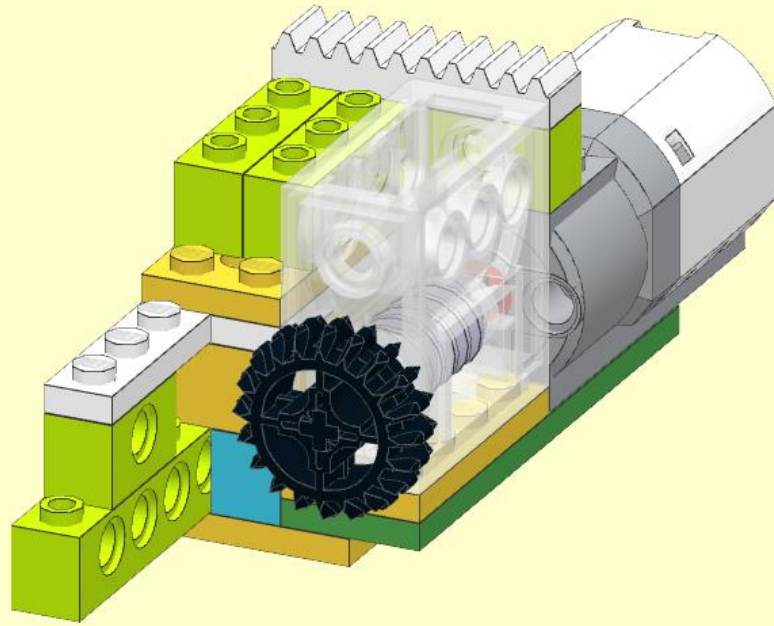

# 11

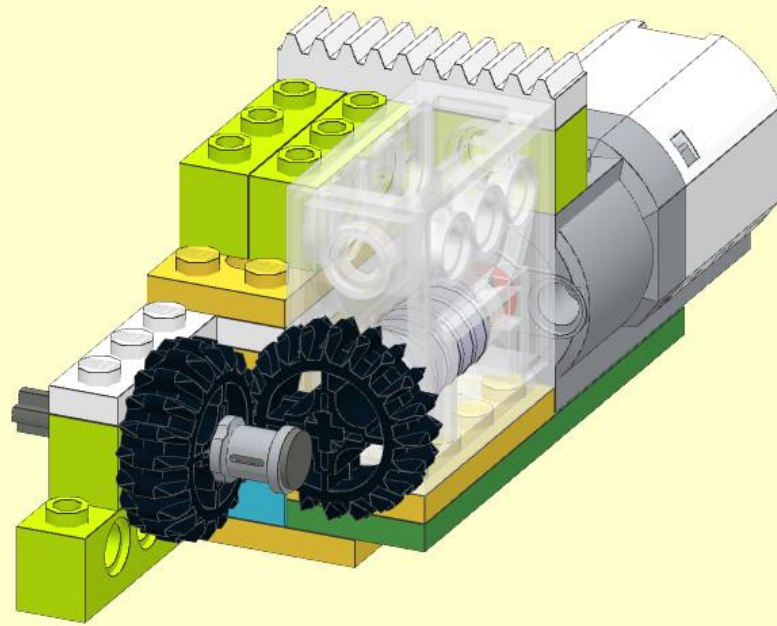
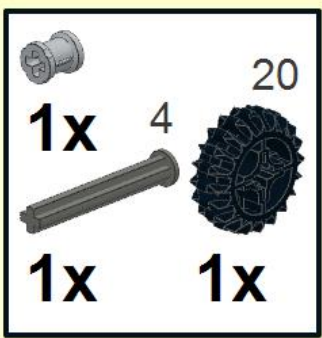

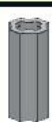
12  1x

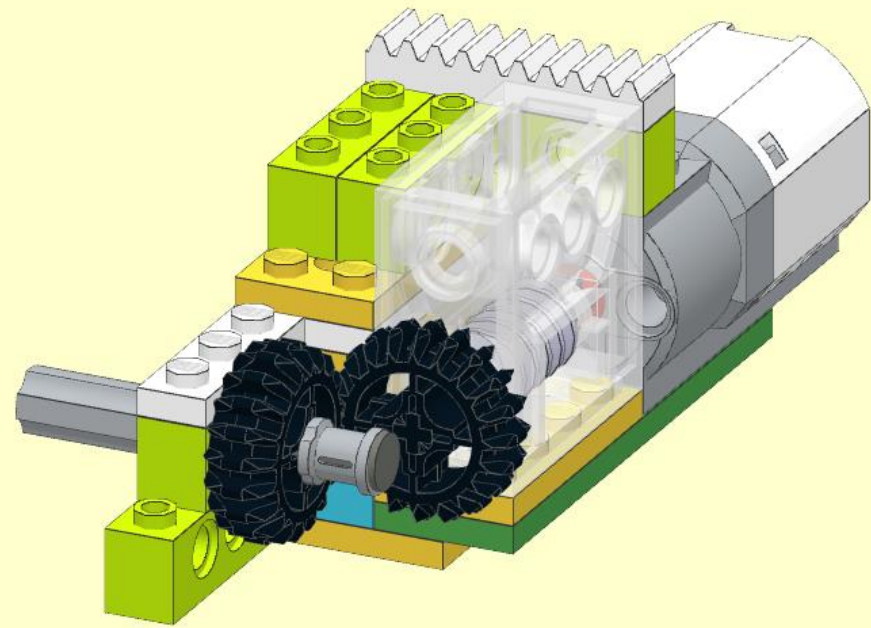

# 13

-  1x
-  1x
-  1x 4
-  1x

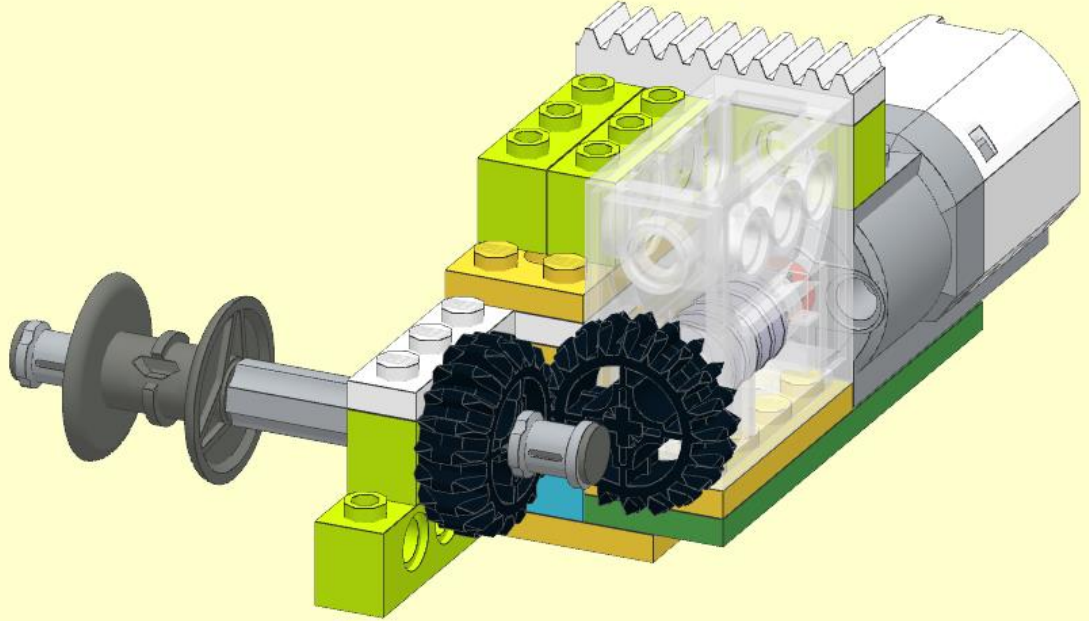



# 14

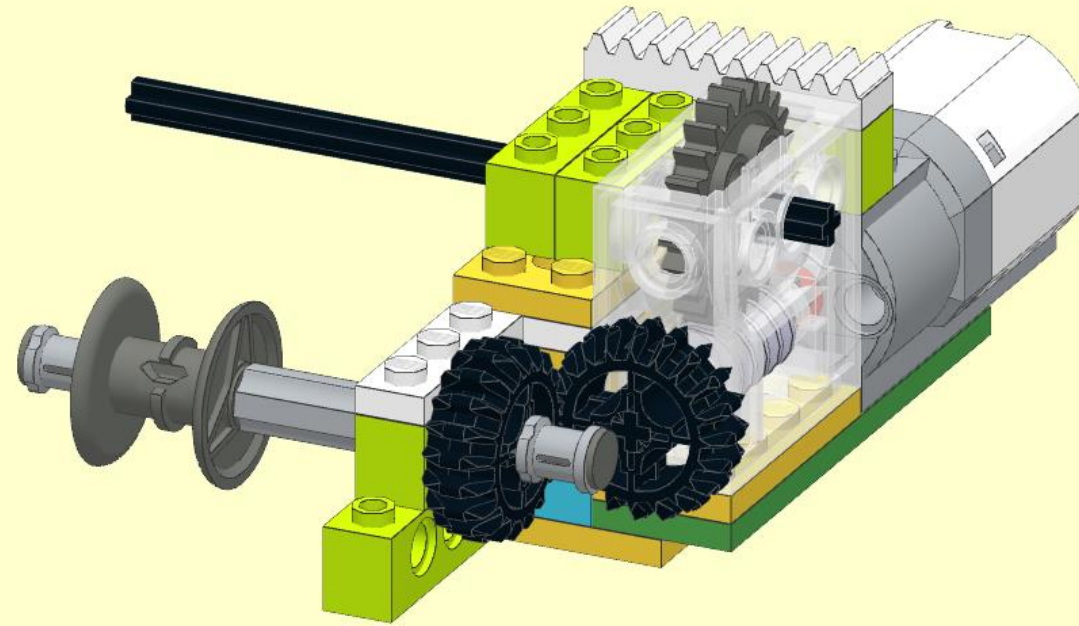
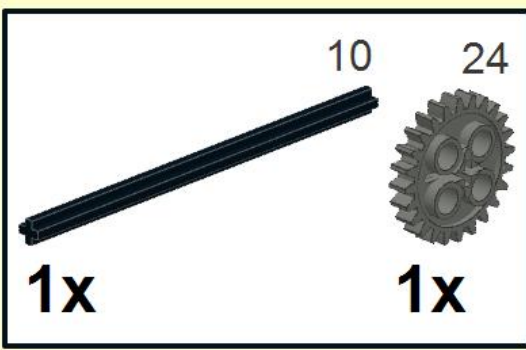

15

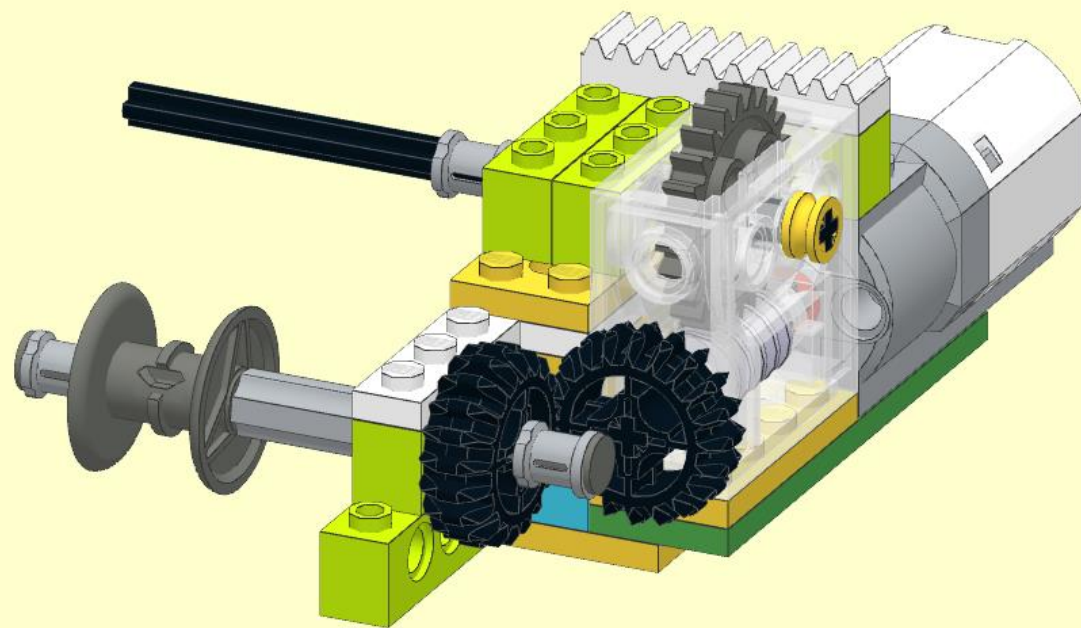
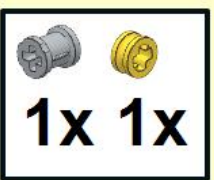

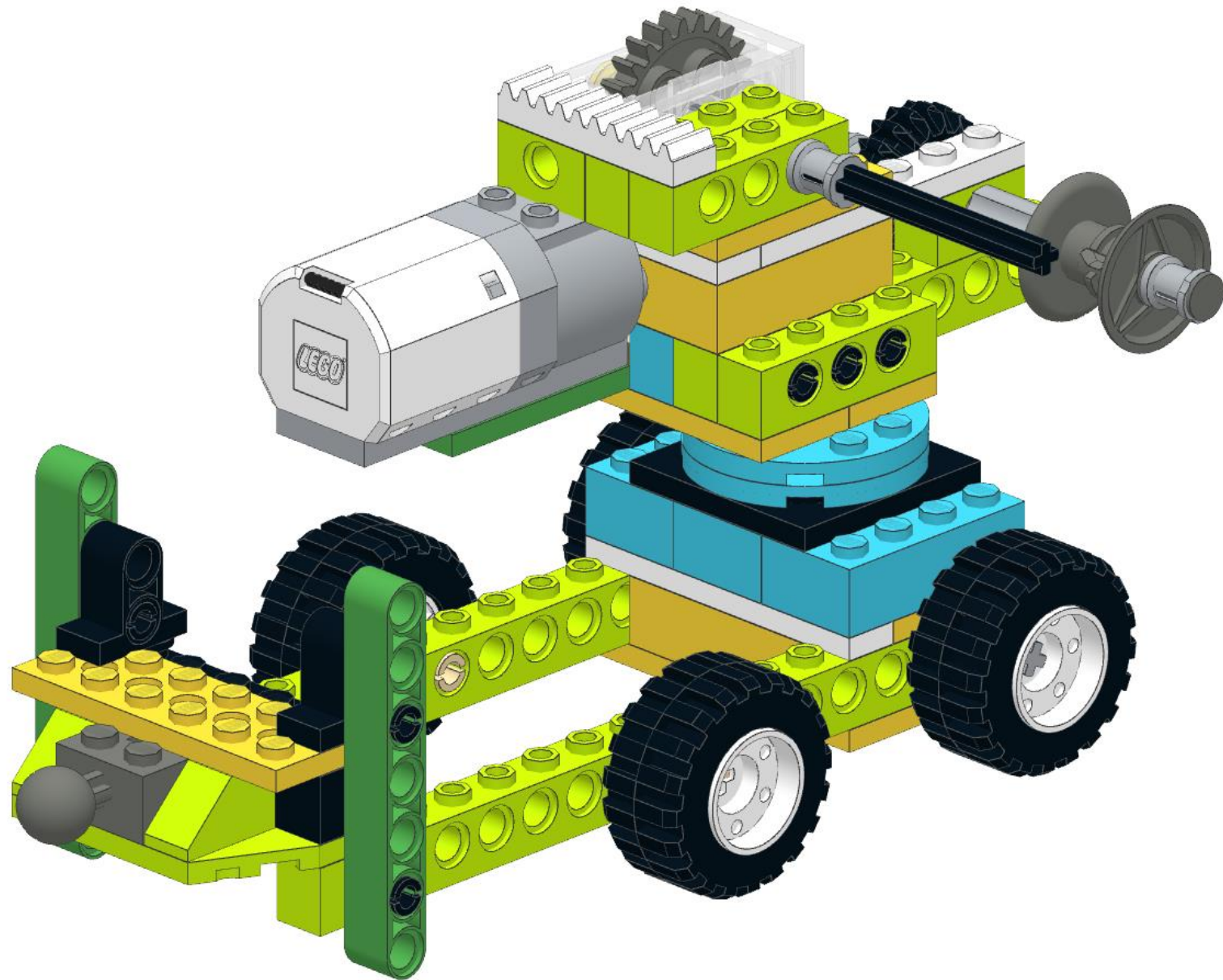

1

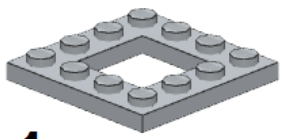

1x

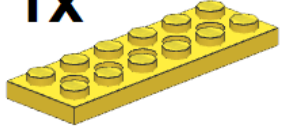

1x

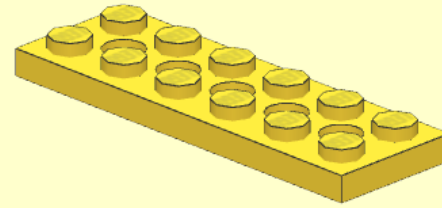
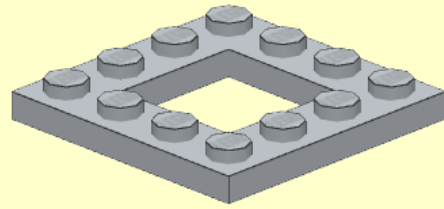

2

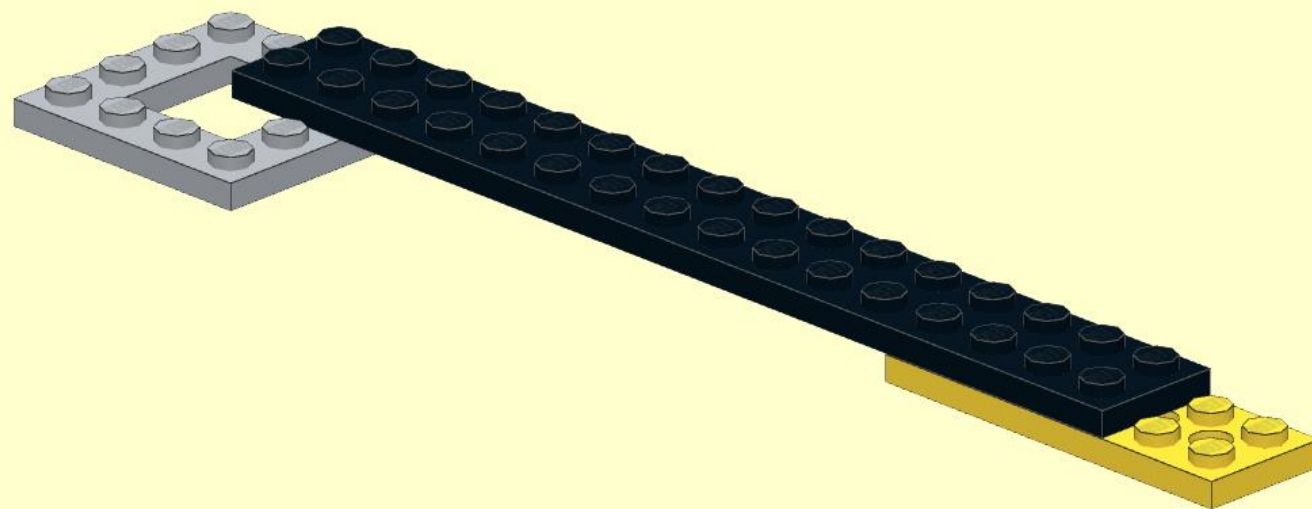
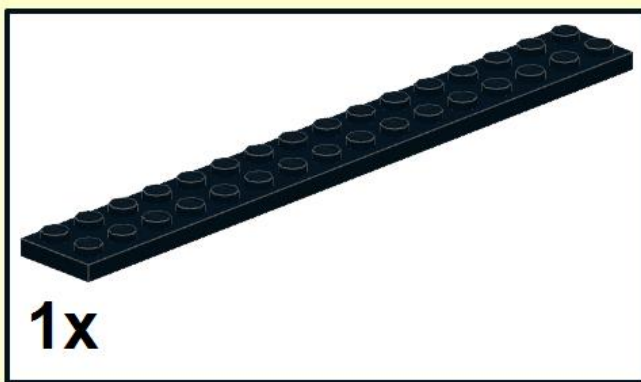

3

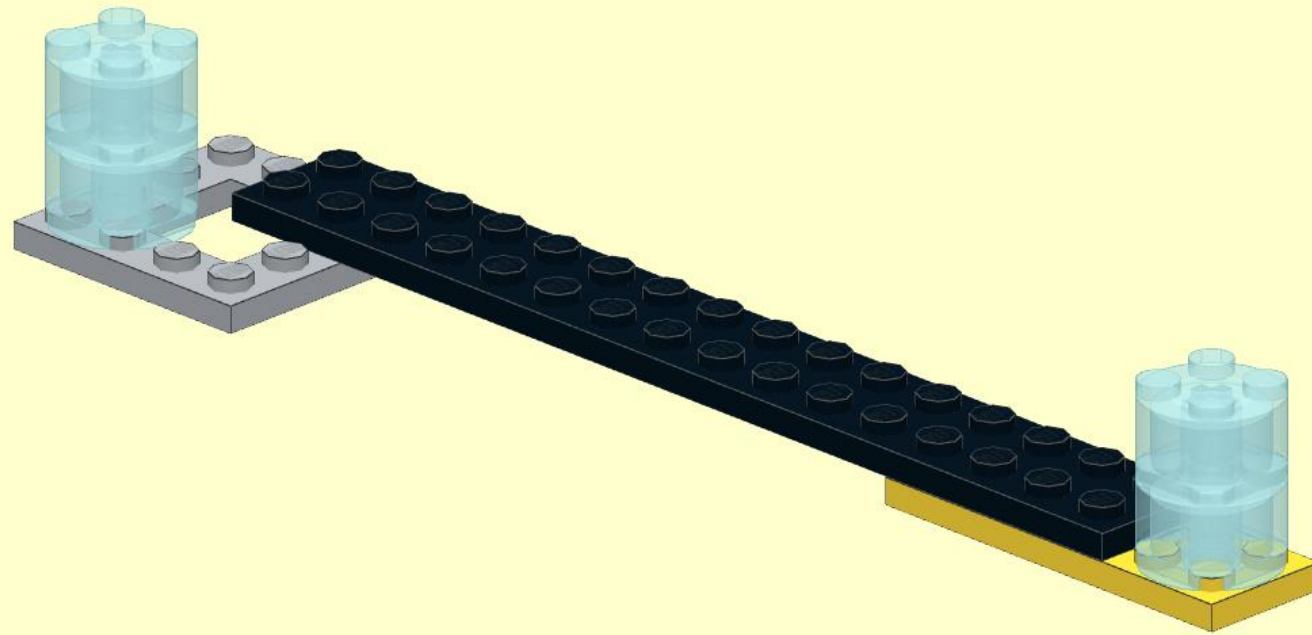

1

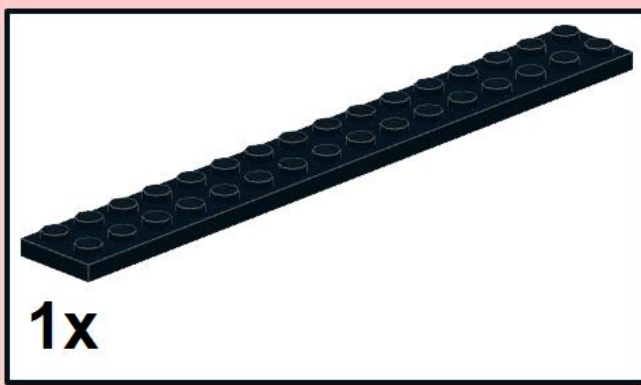

2

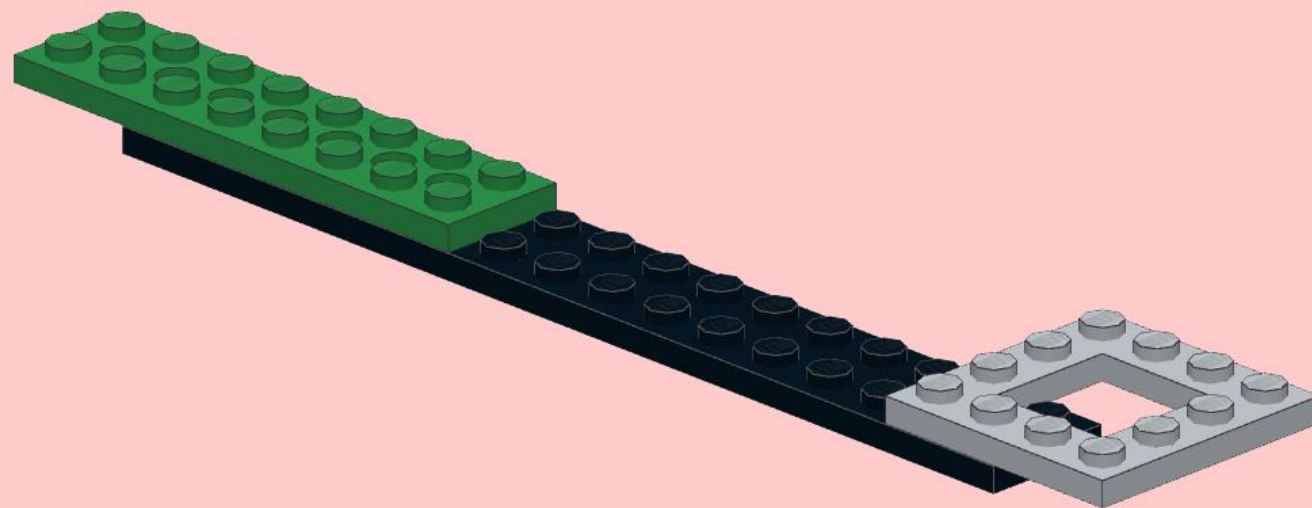
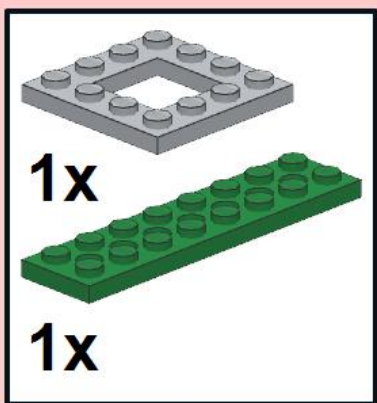



4

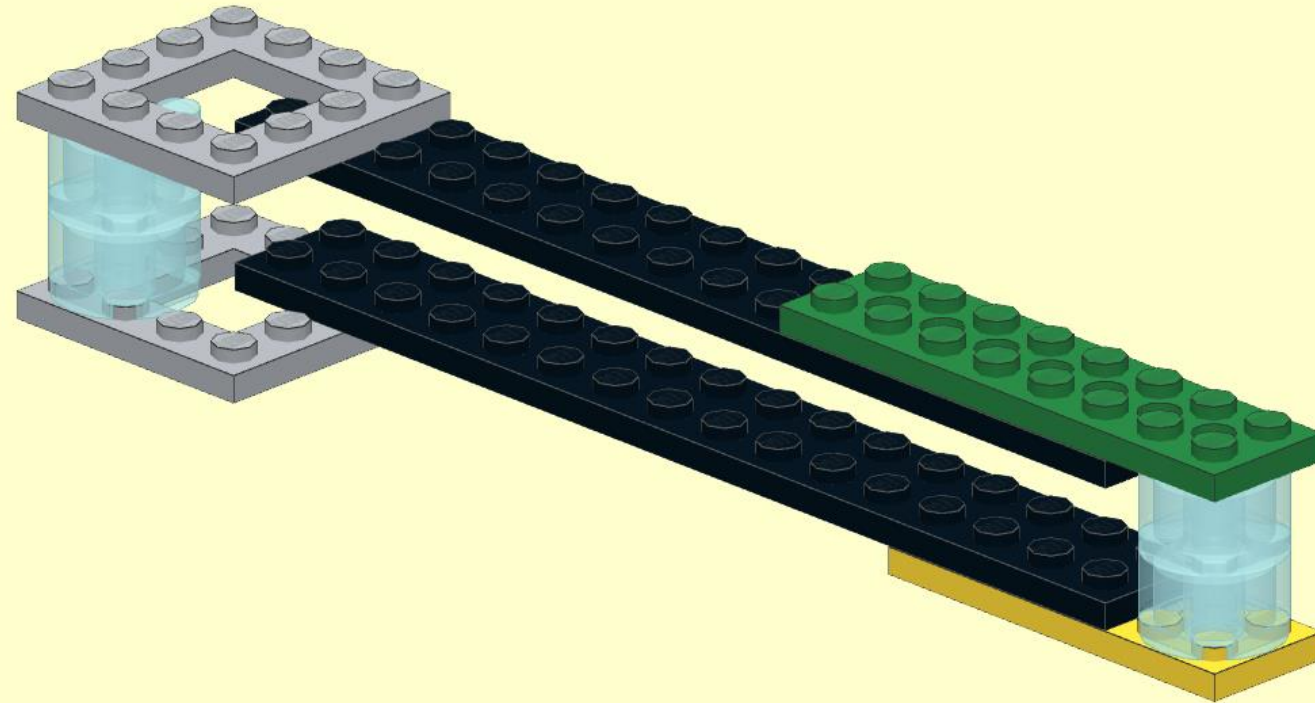

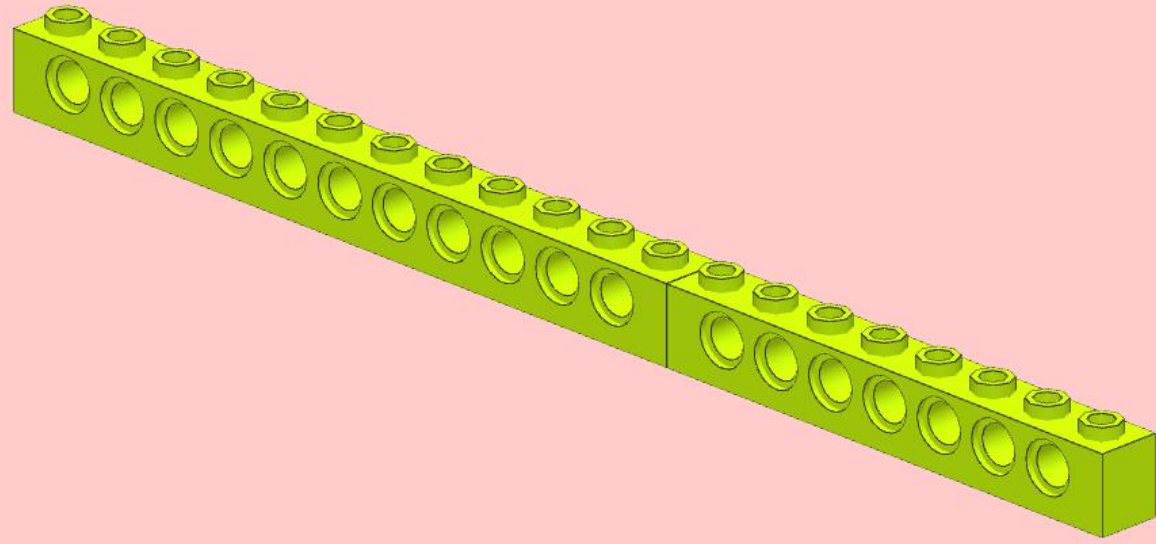
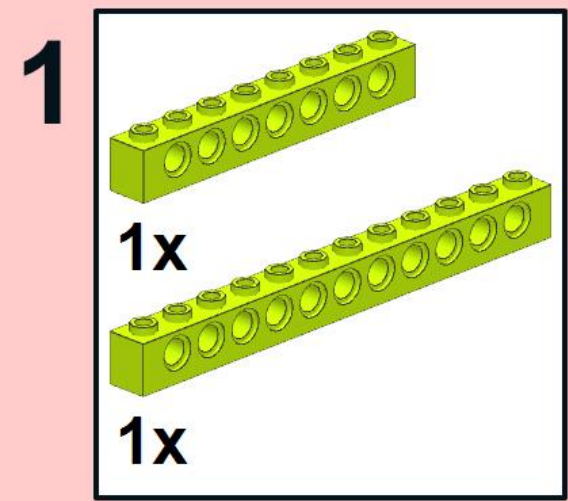

2

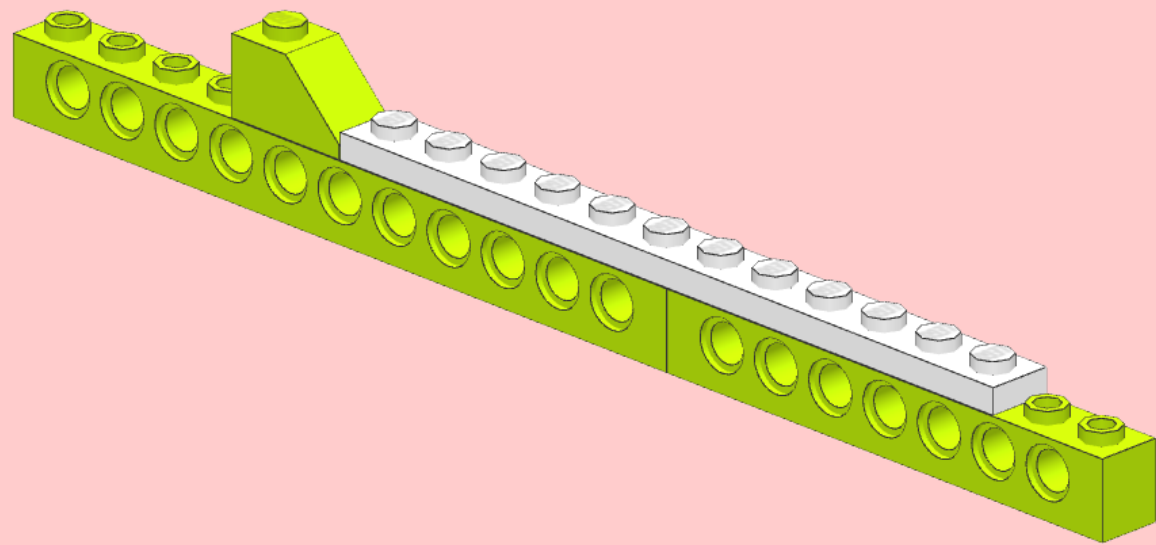
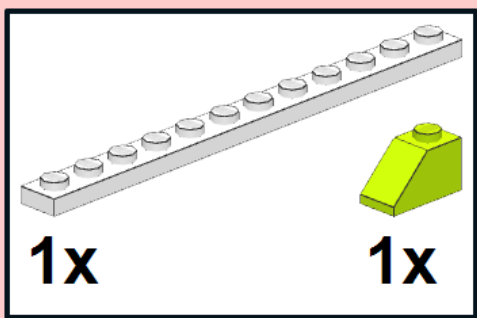

3

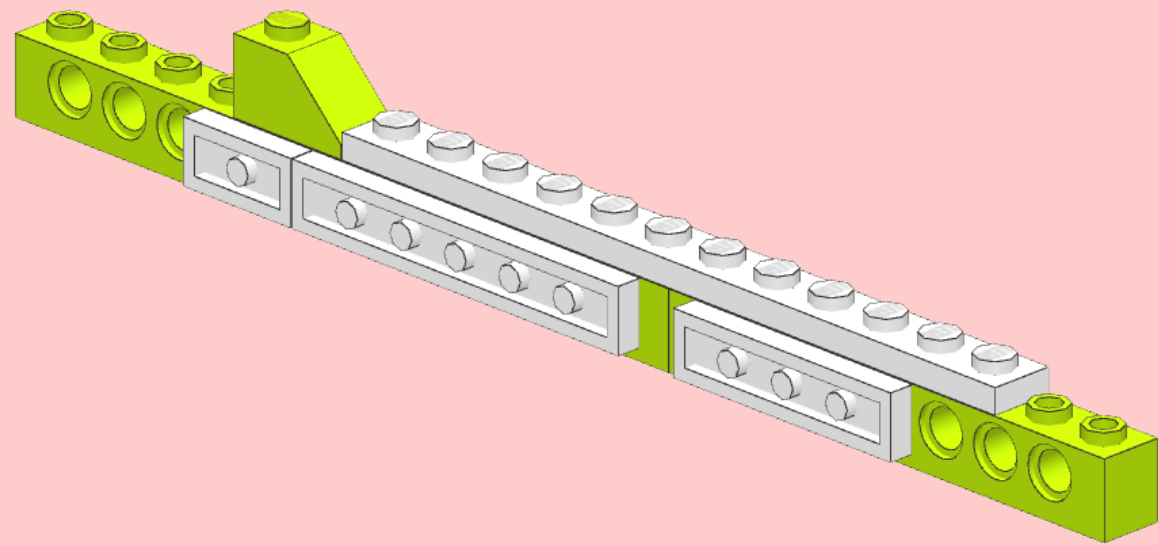
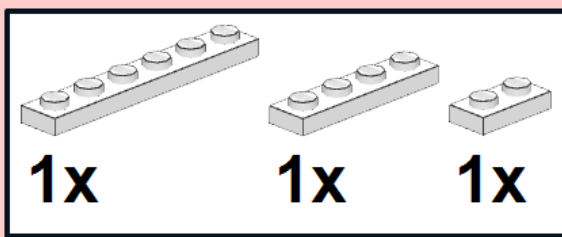

4

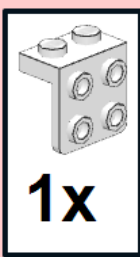

1x

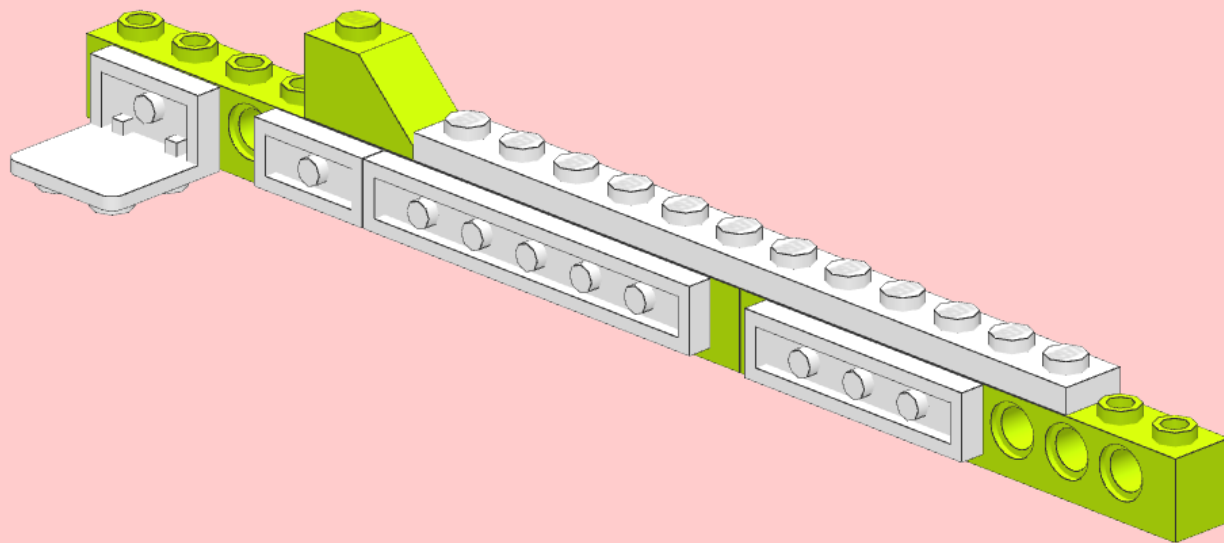

5

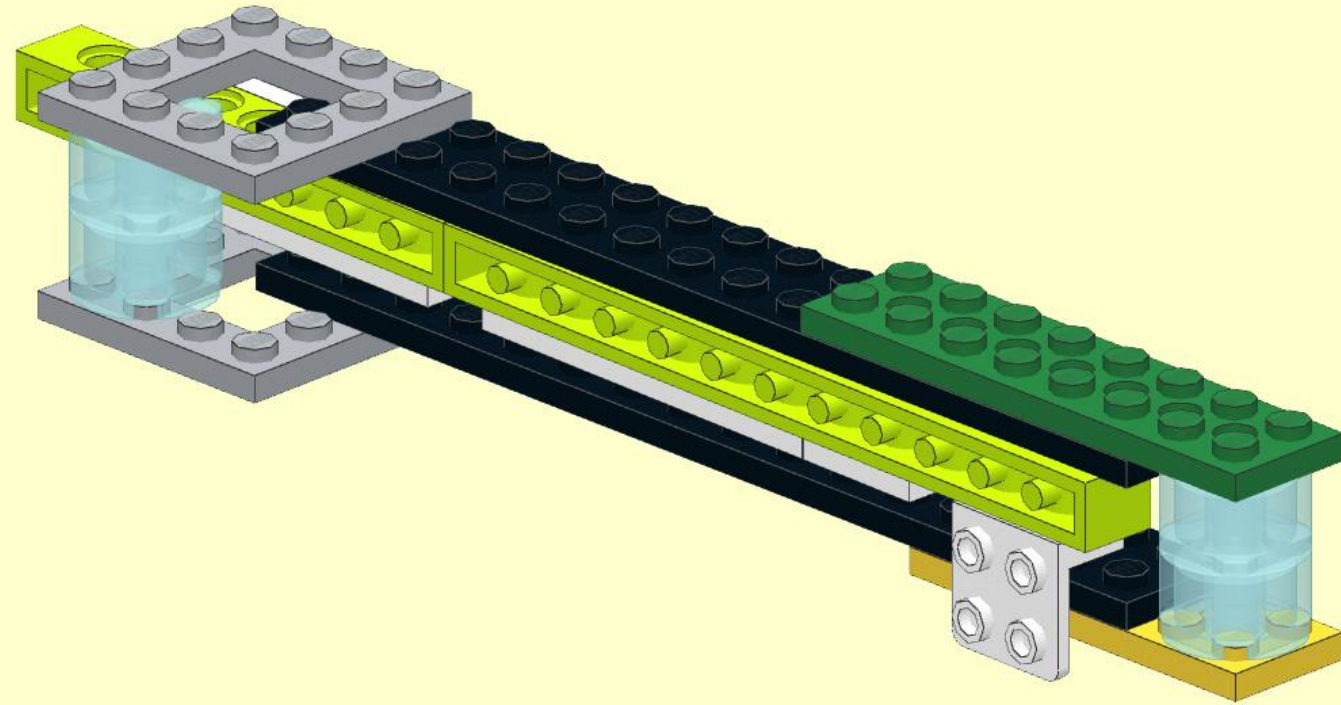

1

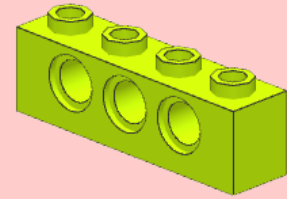
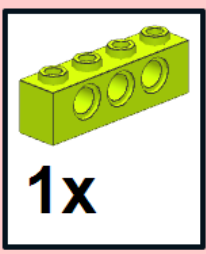

2

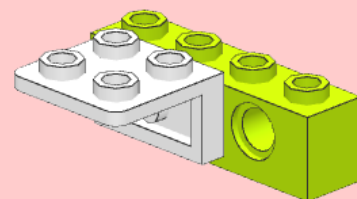
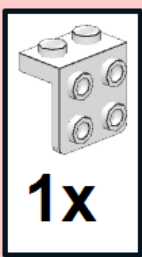



6

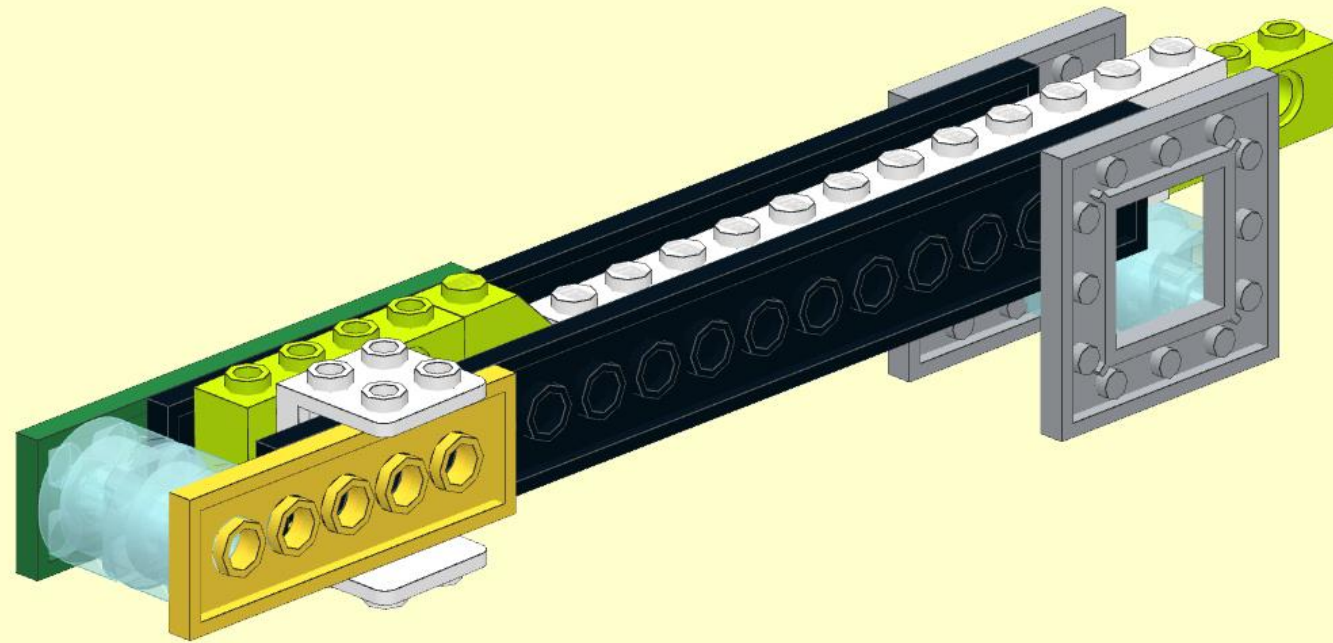

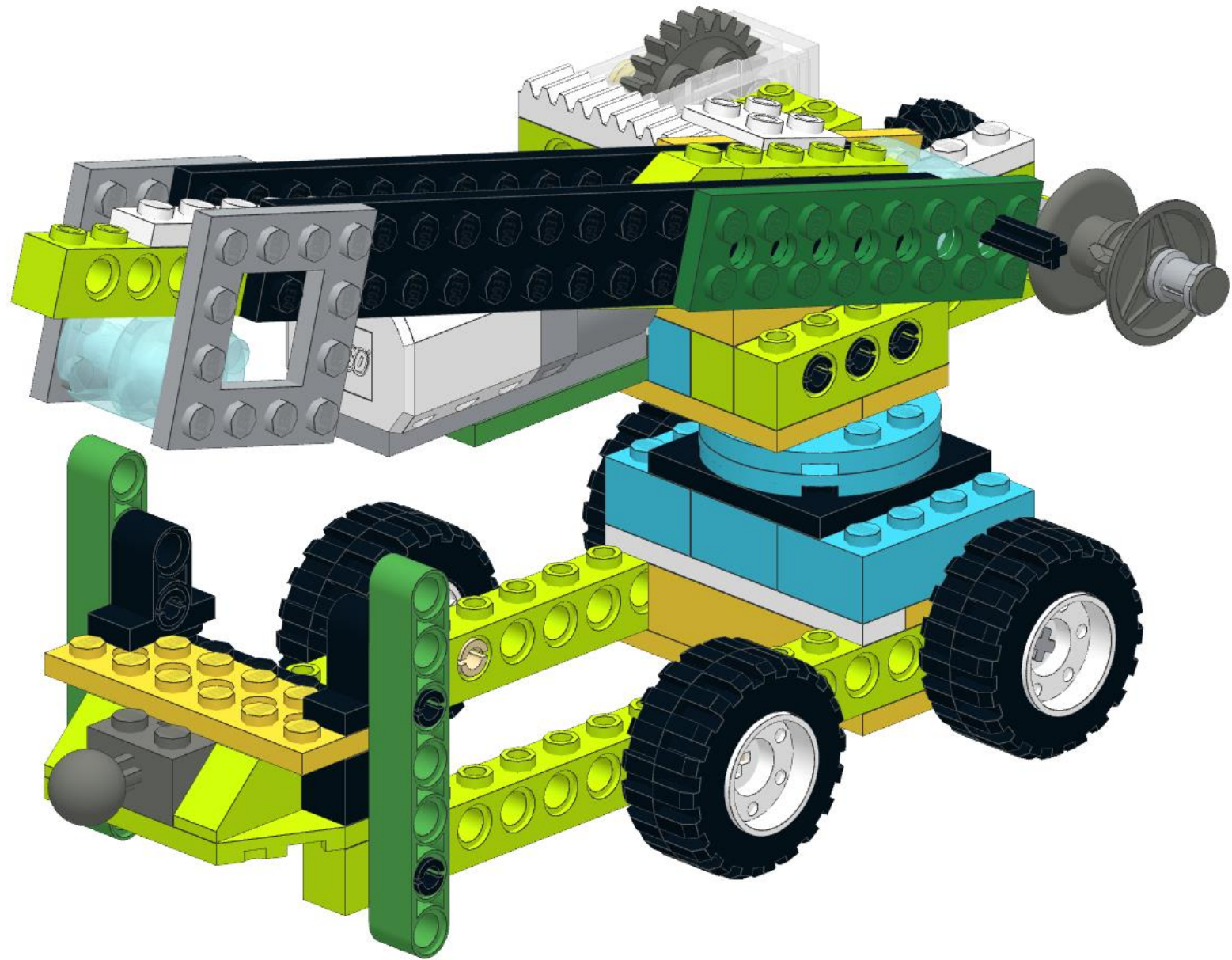

18  1x

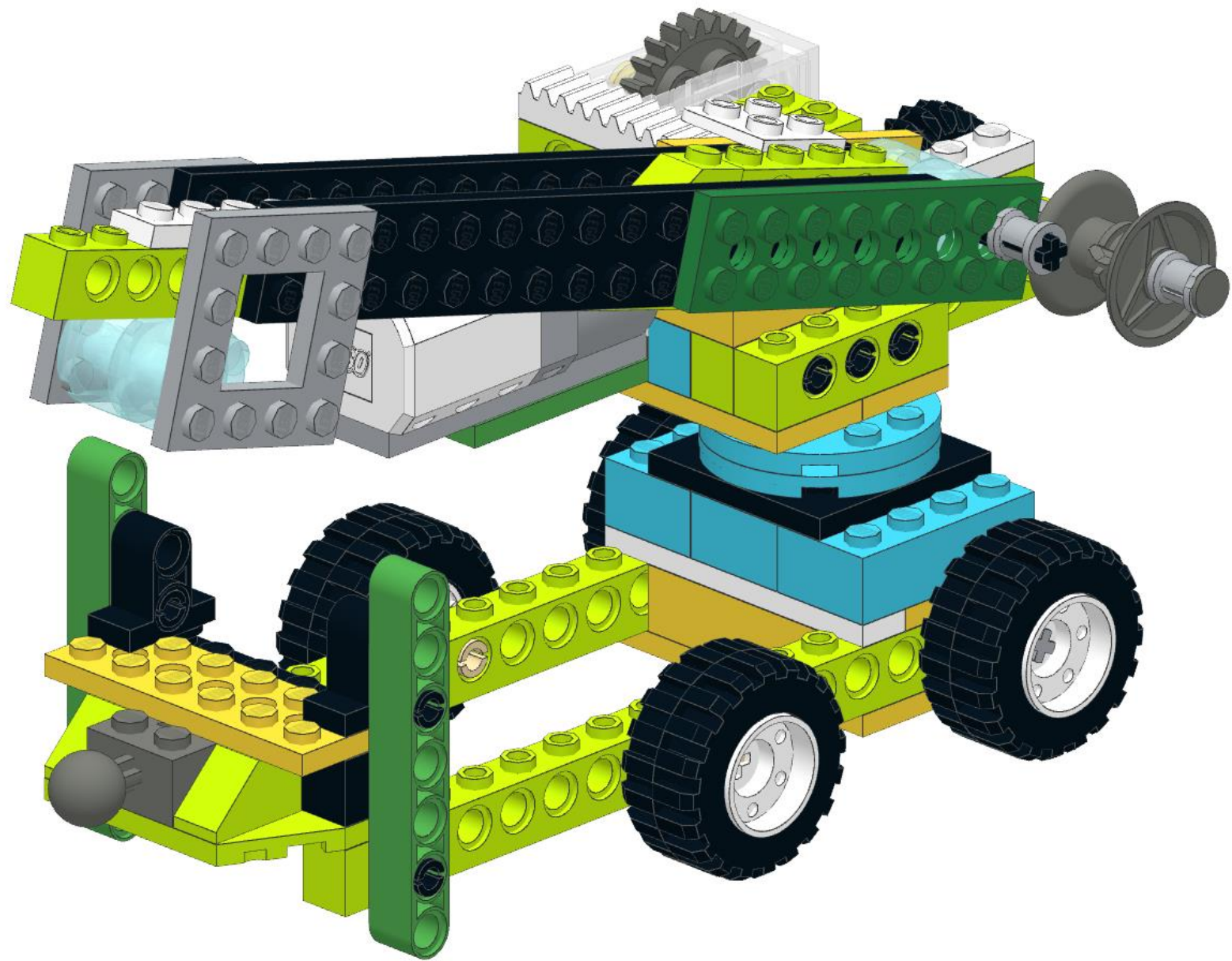

1

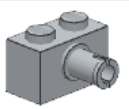

2x

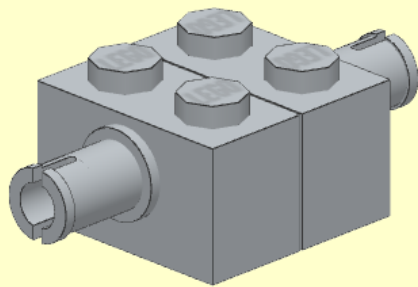

2

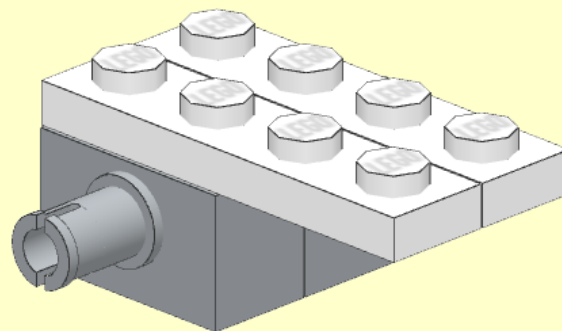
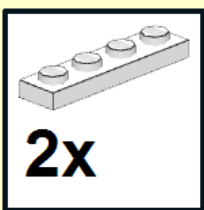

3  
2x

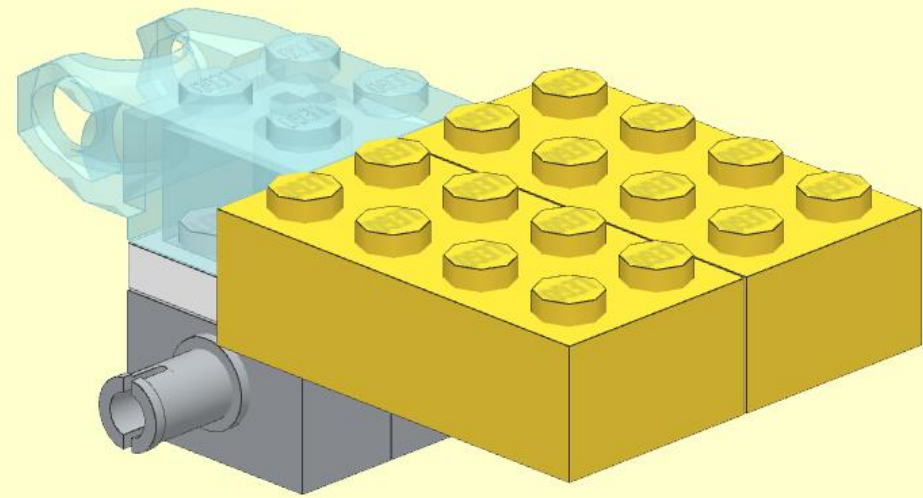

4

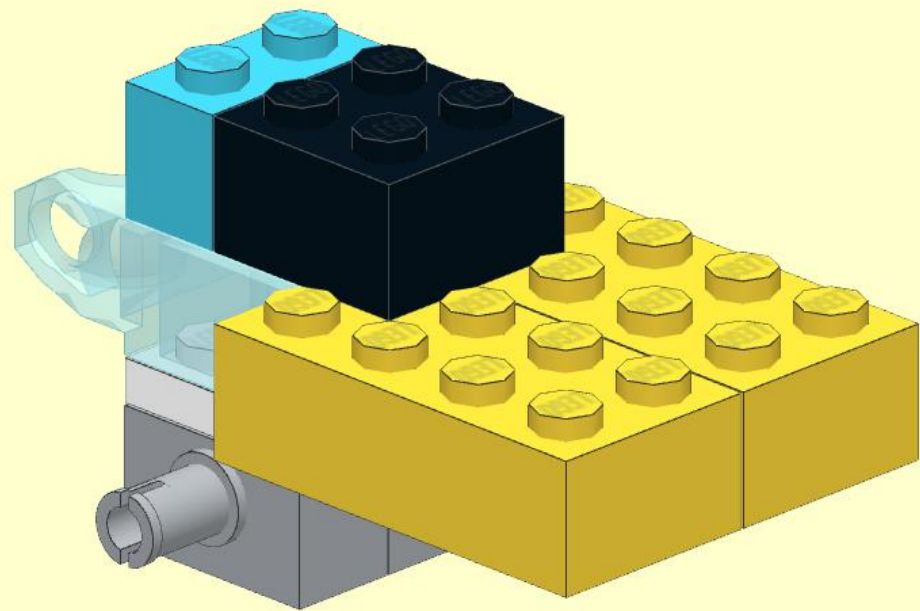
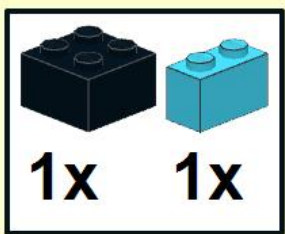

5  
2x

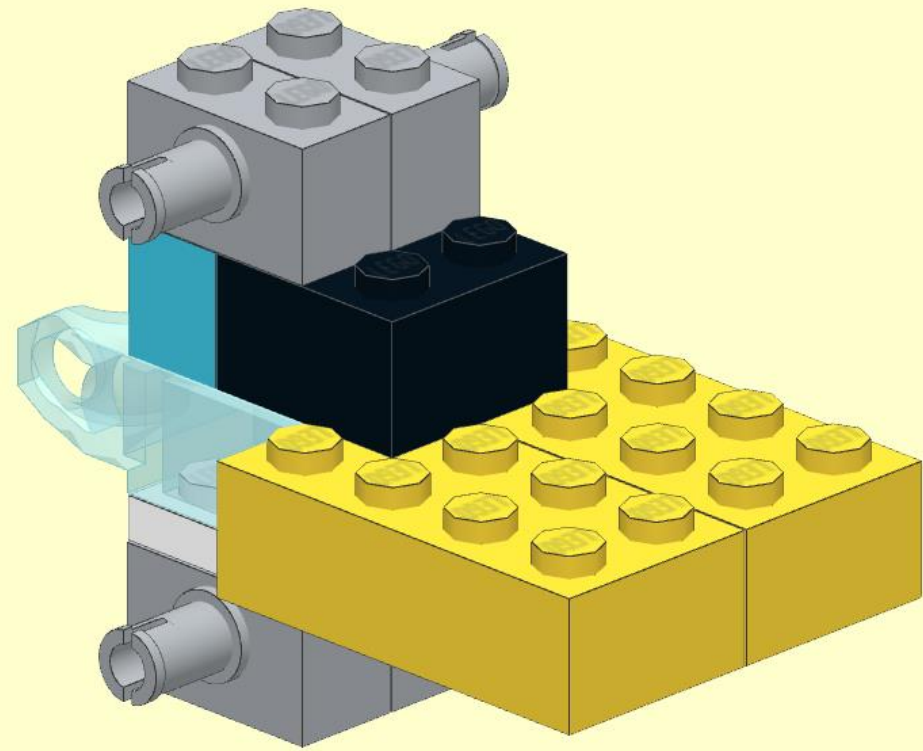



6

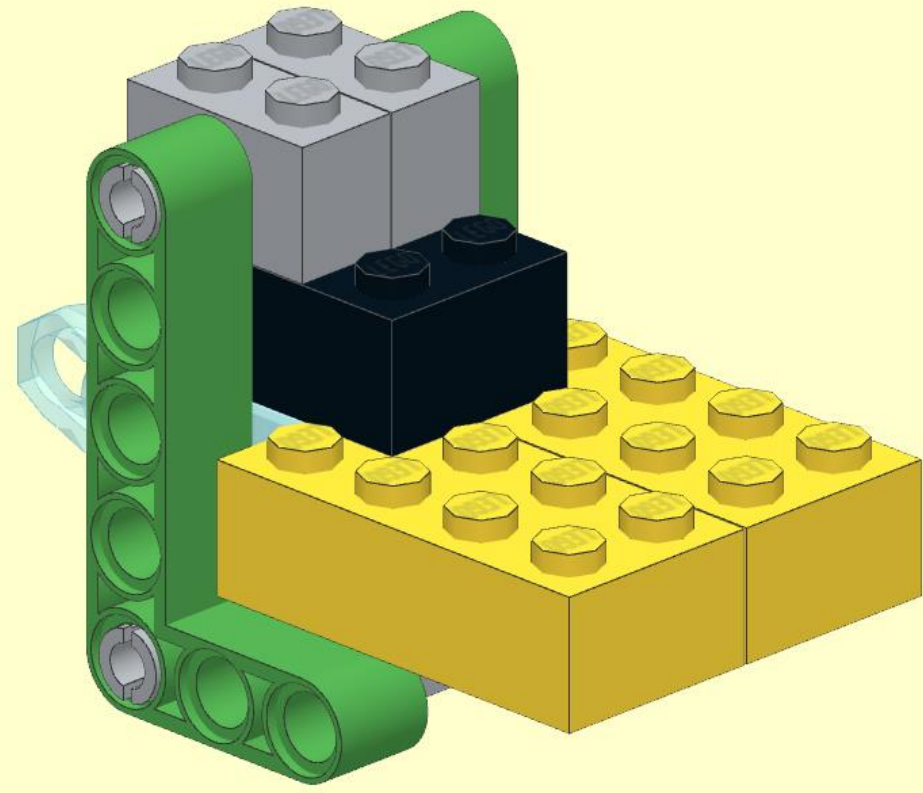
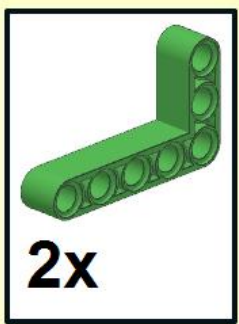

7

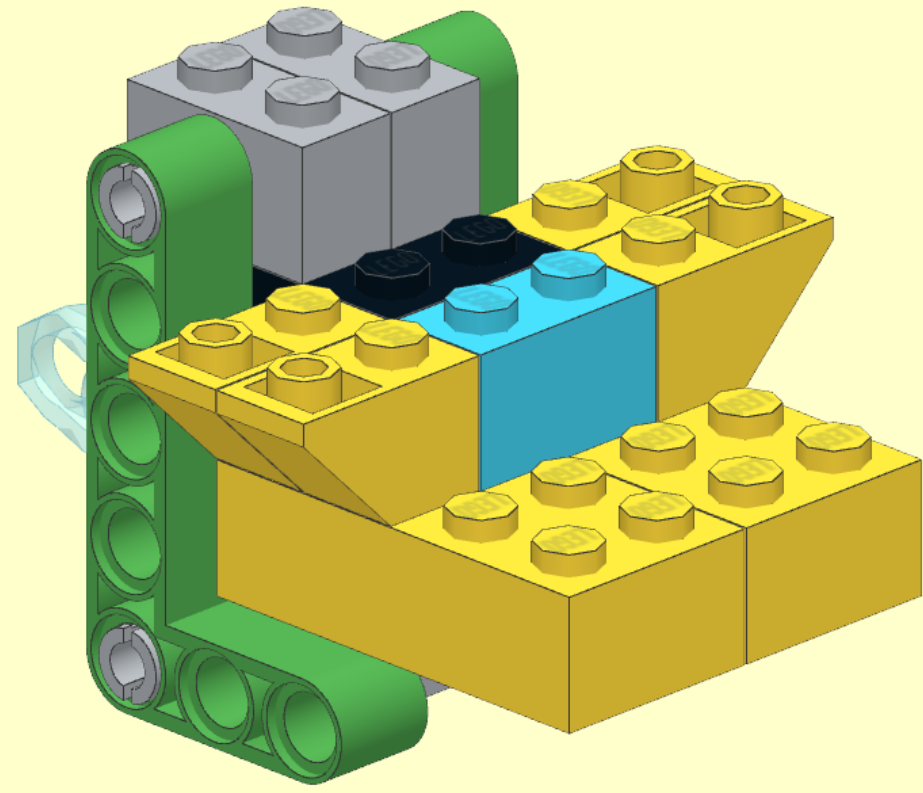
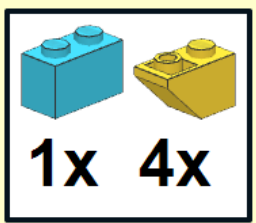

8

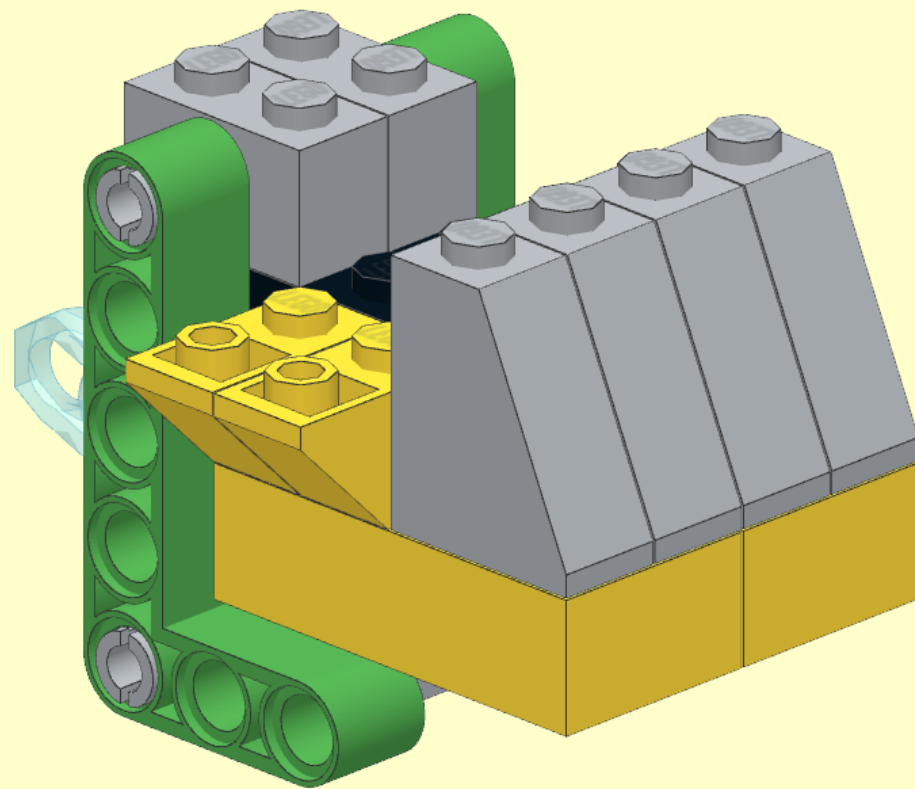

9

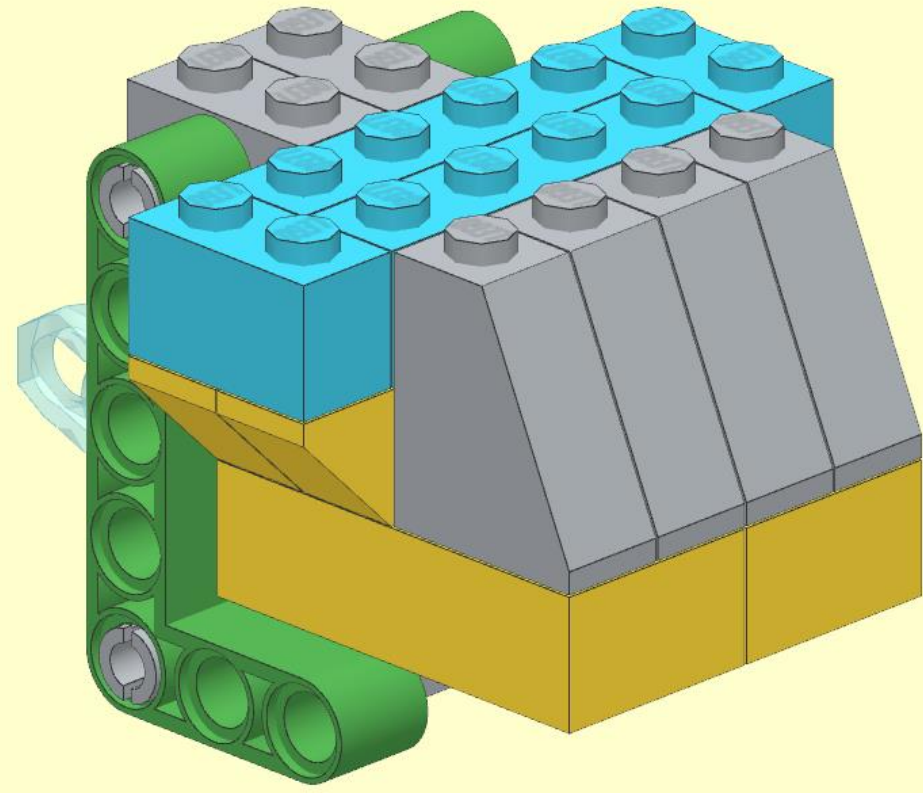
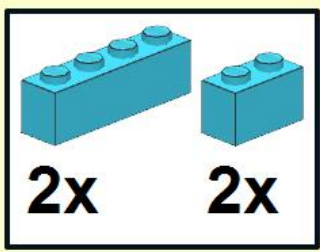

# 10

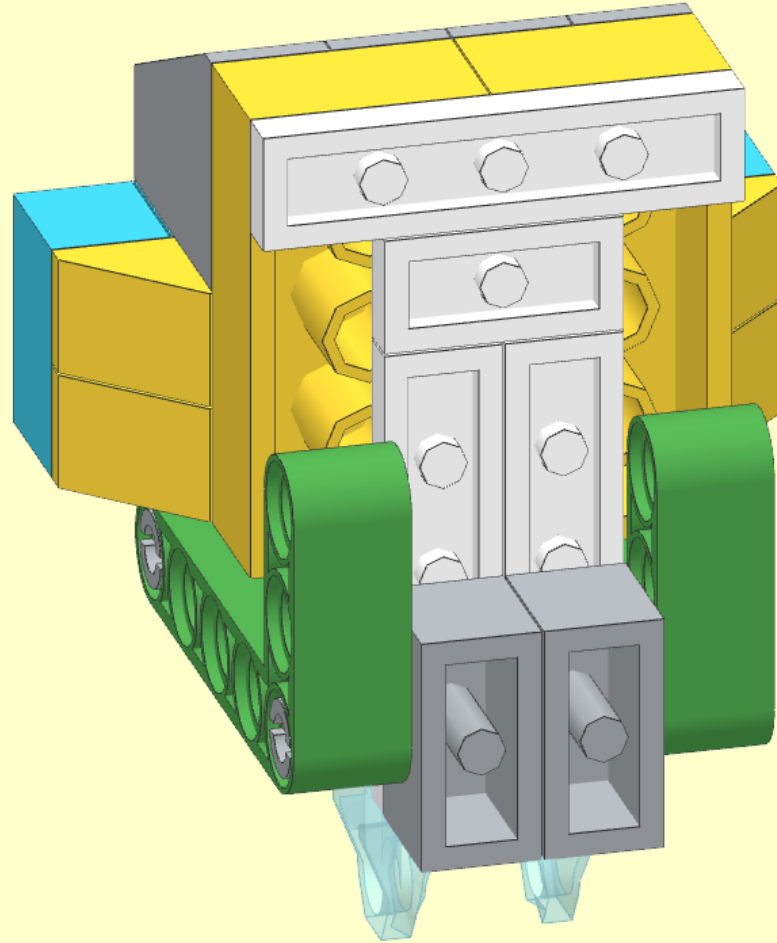
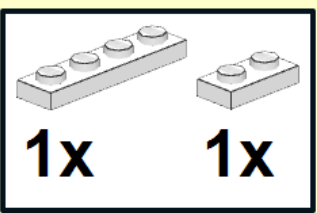

11

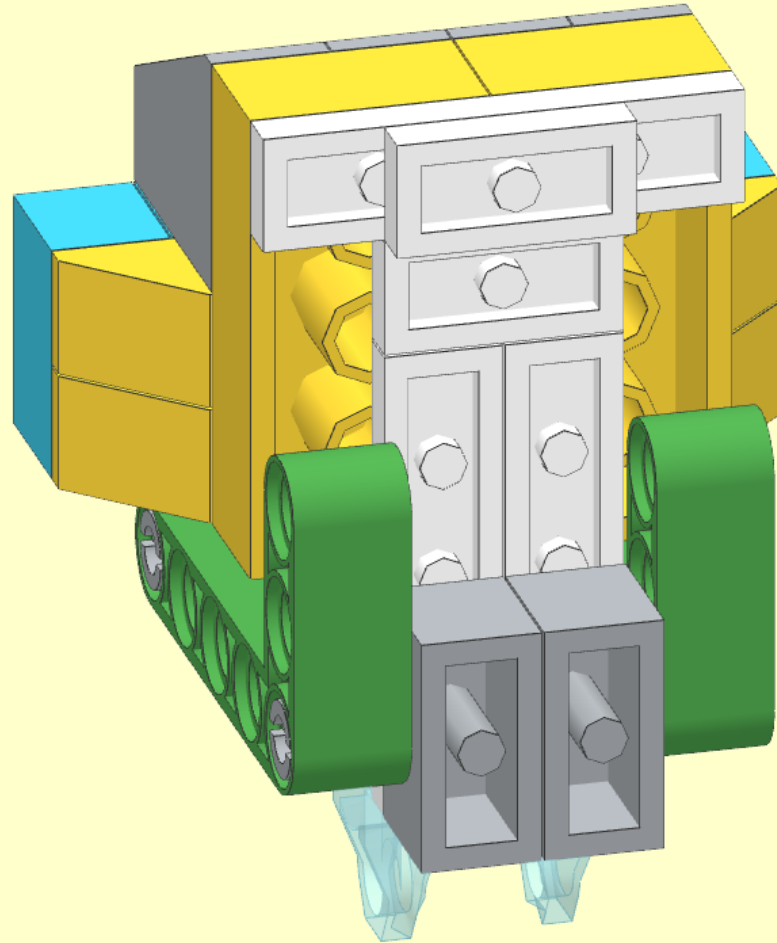
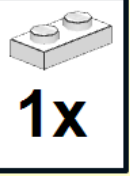

12

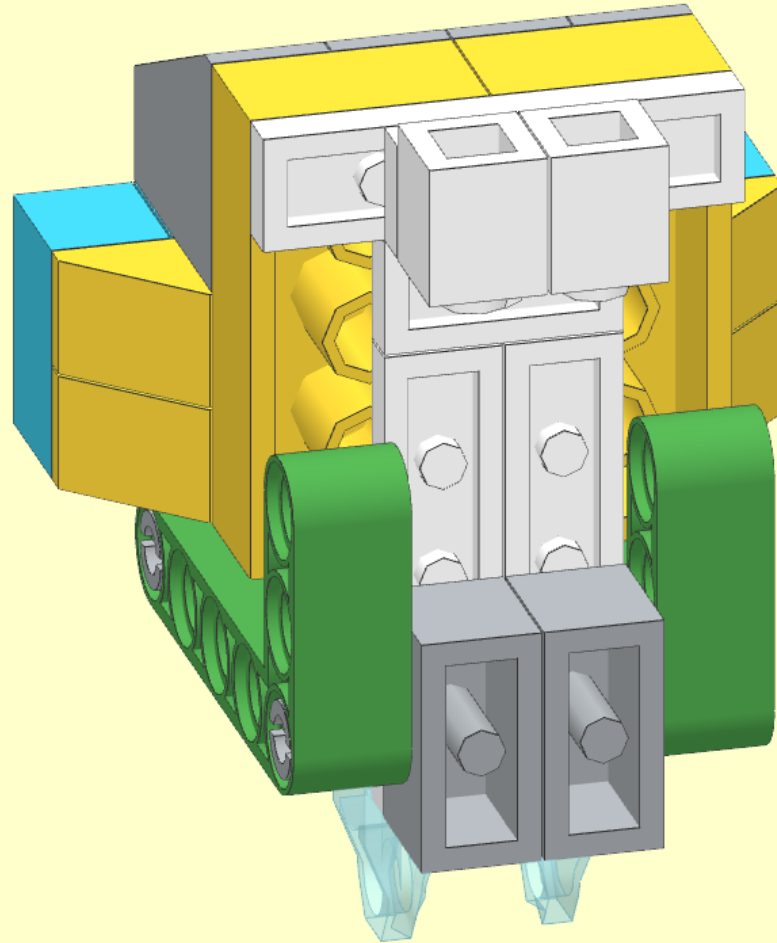
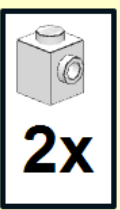

13

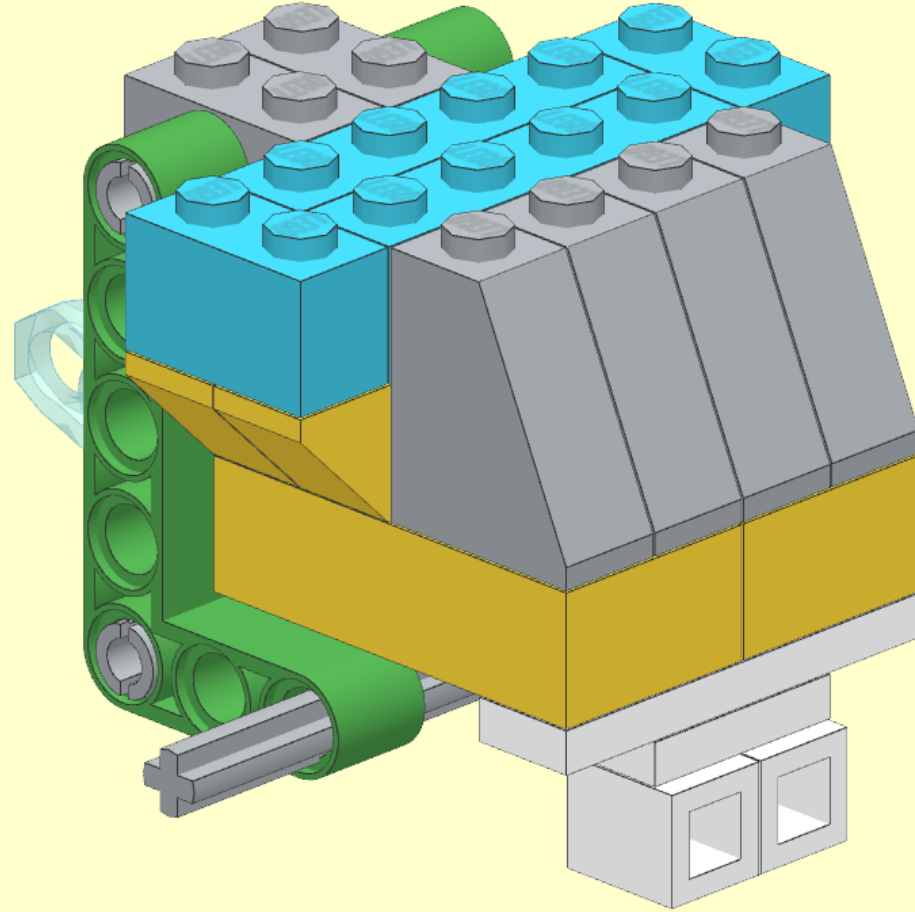
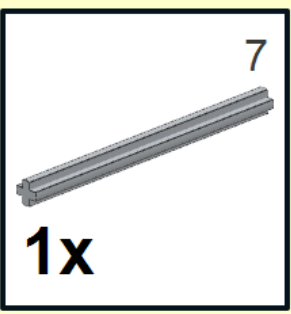



14

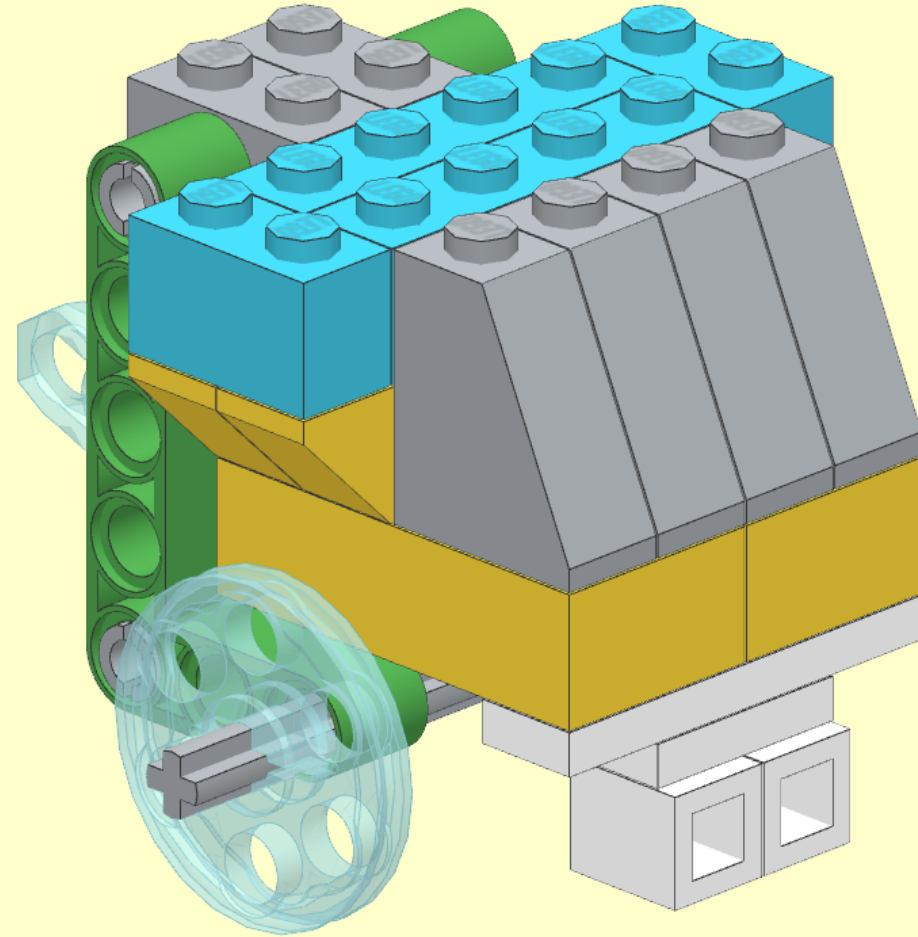

15

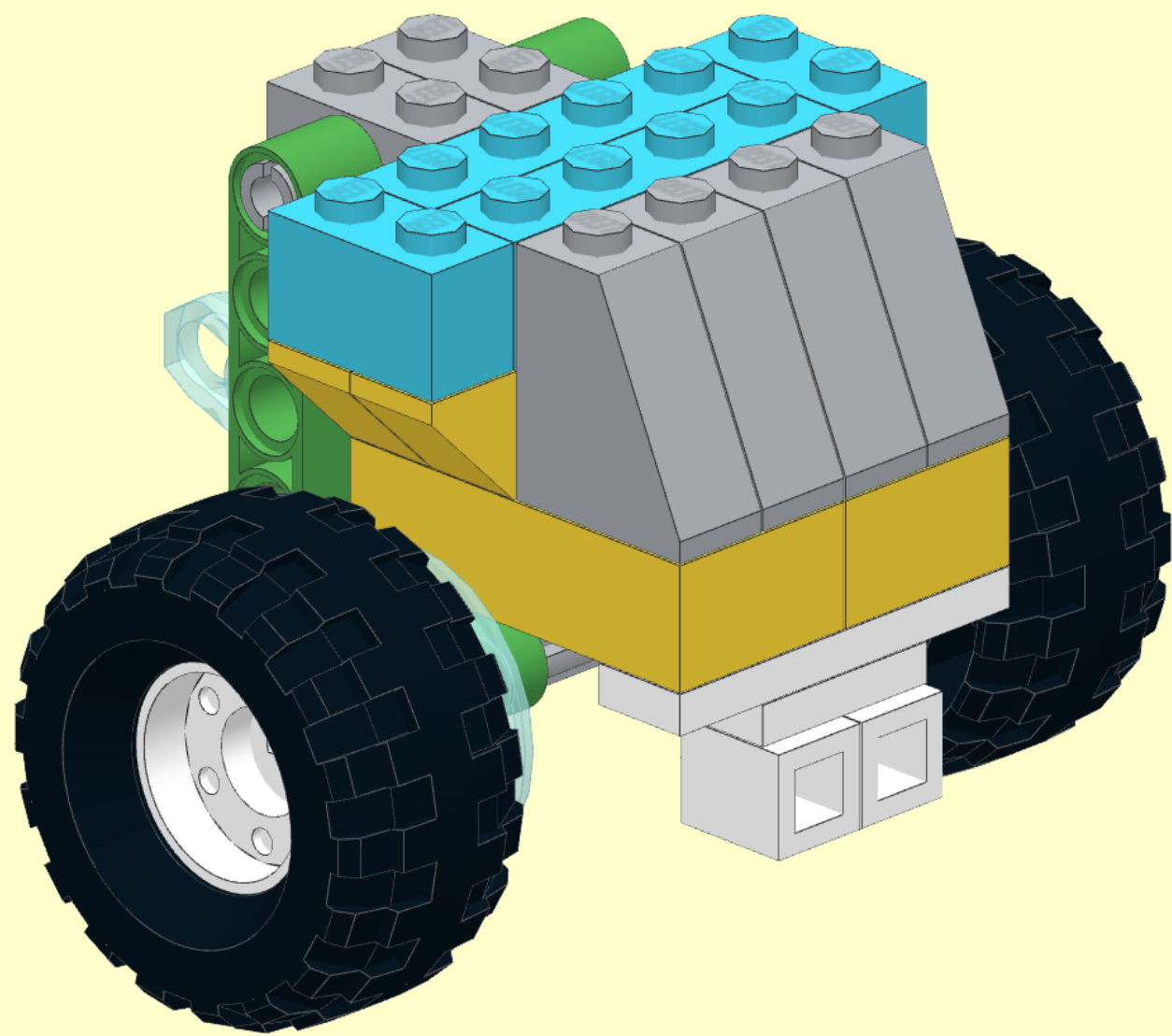
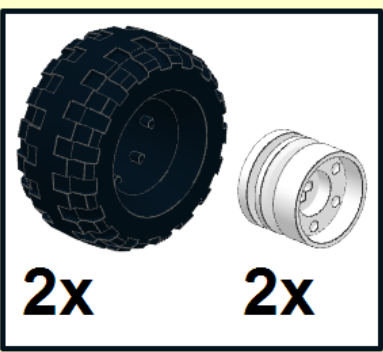

16

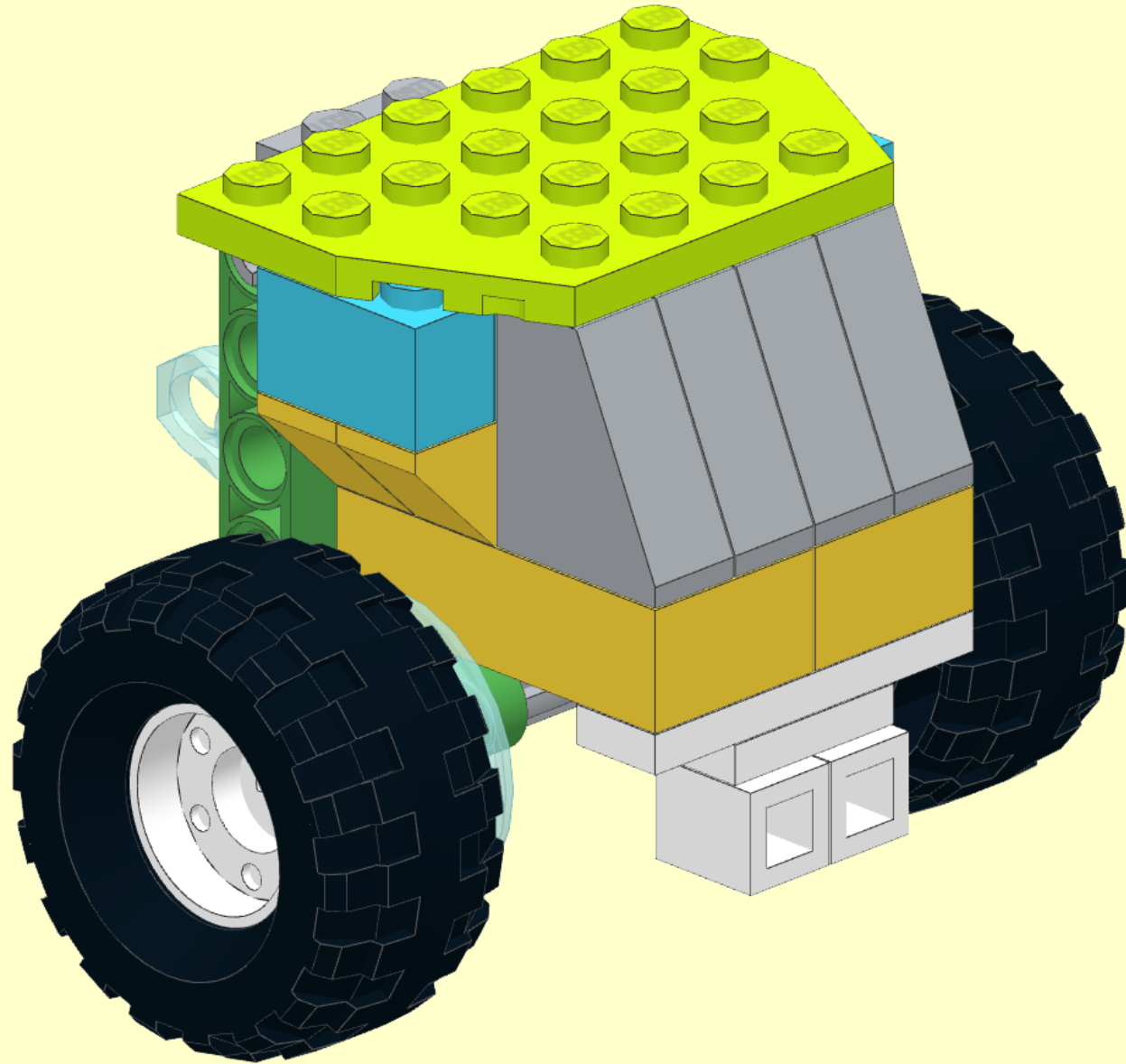
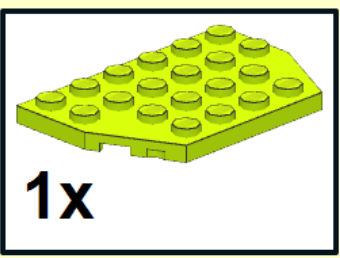

17

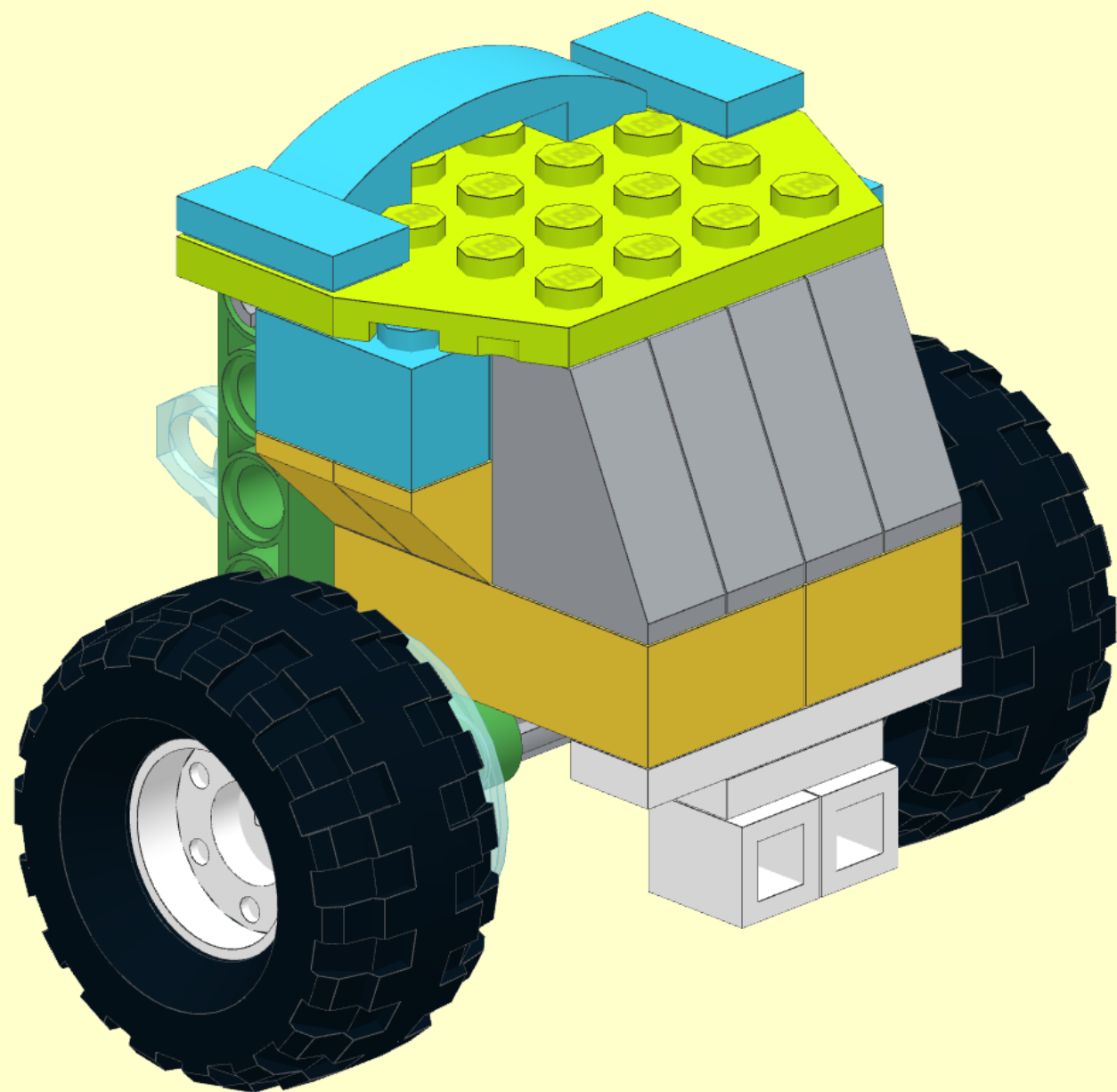
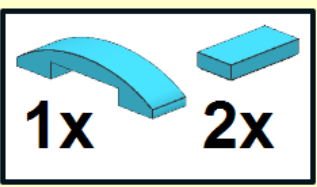





1. And now we will write a program for running the winch in one direction, the other and, which is VERY IMPORTANT - stops.





2. In order to remotely control our crane, we need a distance sensor. Write a program that turns on the hoist when the sensor shows an approximation. Includes the winch for lowering when the sensor shows a distance.



3. Now independently write the program that controls the winch like the previous one, but with the help of the tilt sensor.

Find the error.

The programmer wrote a program for the robot, which should include a motor for 9 seconds, but the engine somehow works longer.



Explain what this program does.



More buildings from Anger project on  
<https://play.google.com/store/apps/developer?id=AnGer+project>

AnGer  project