

1

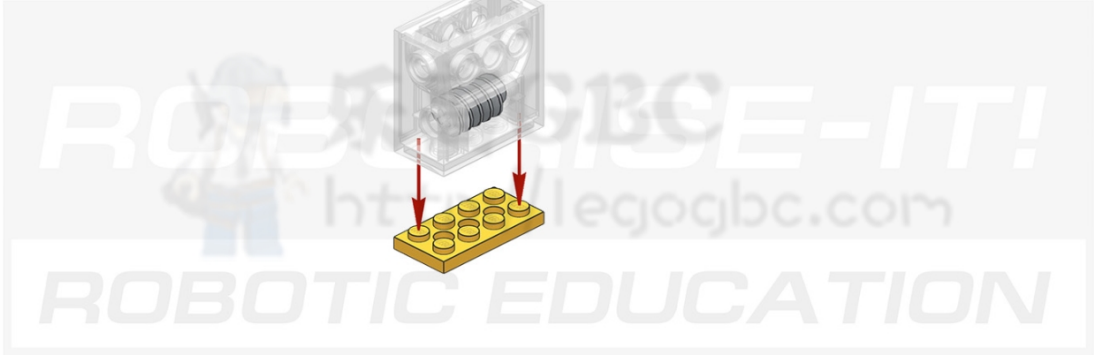

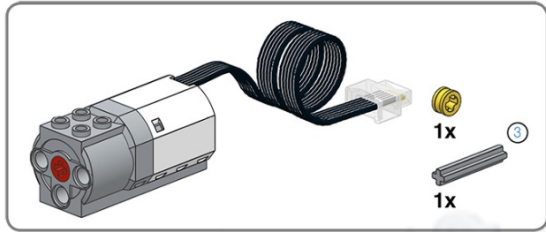

2

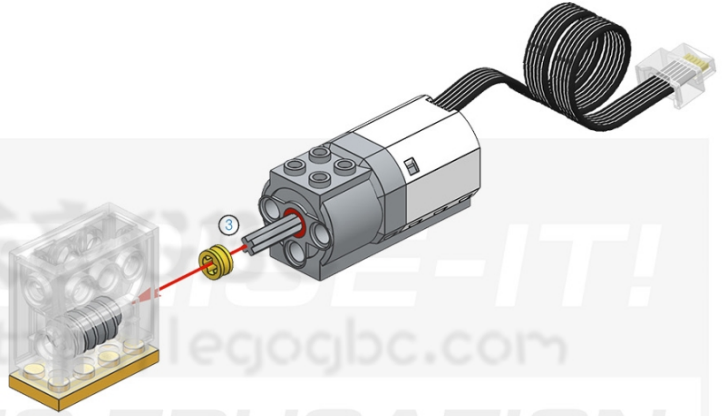

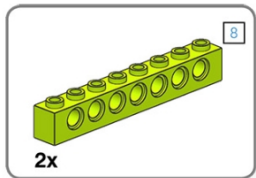

3

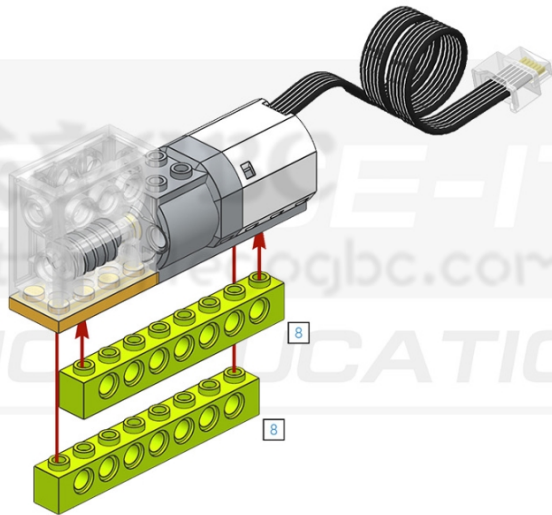

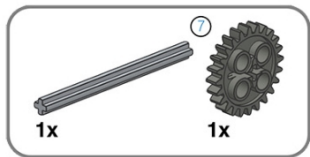

4

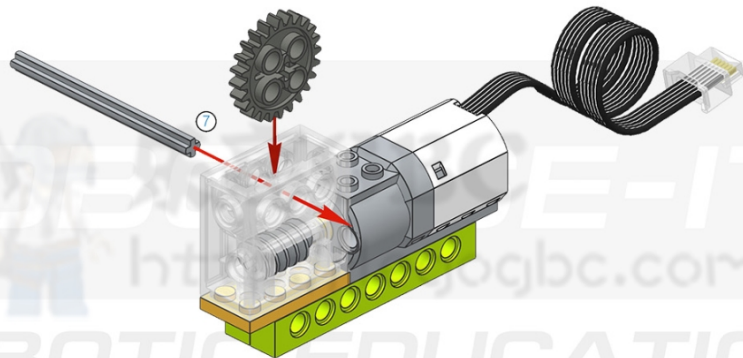



5

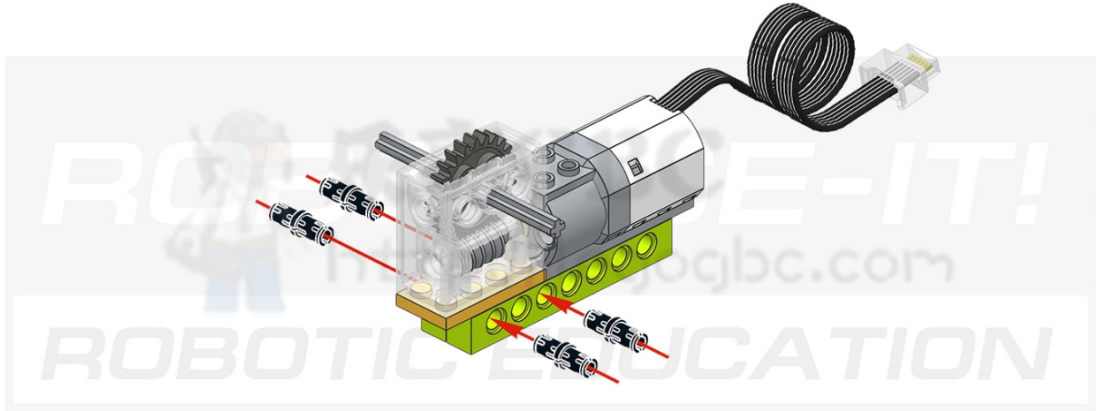

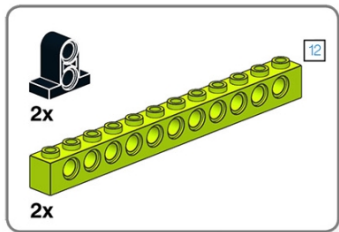

6

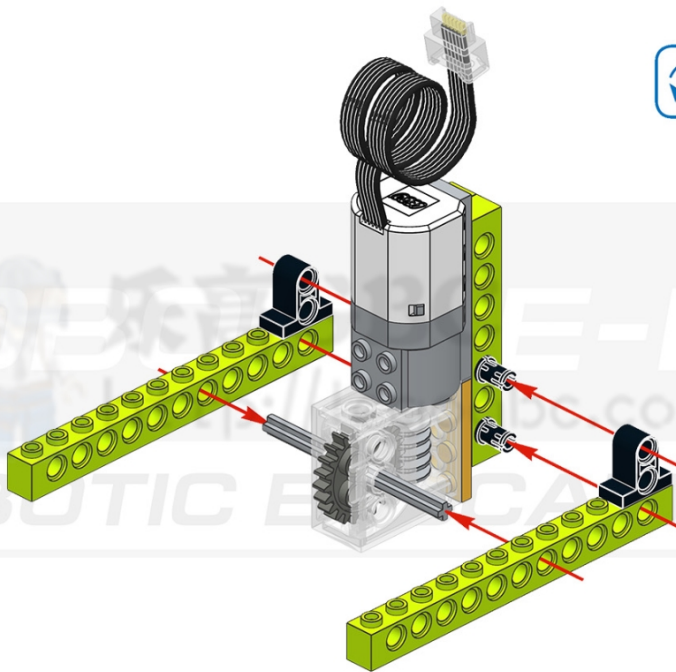

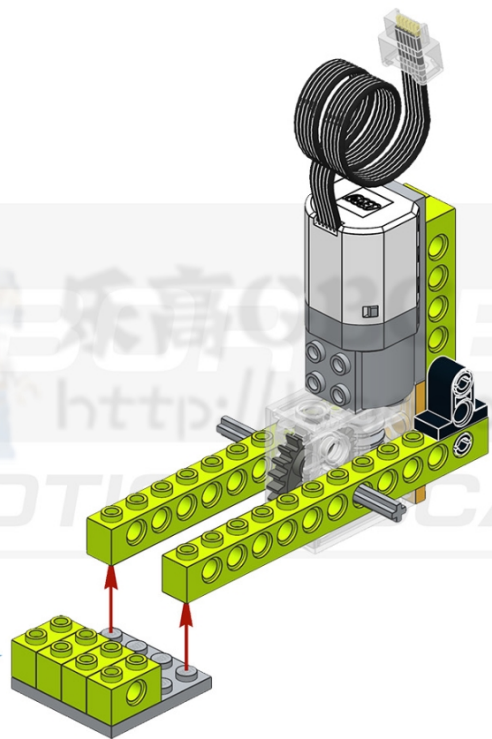
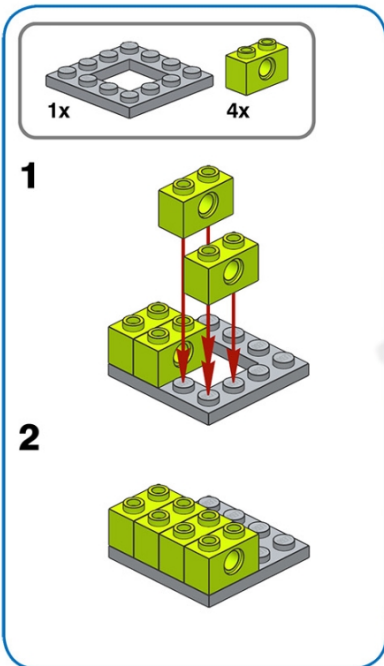

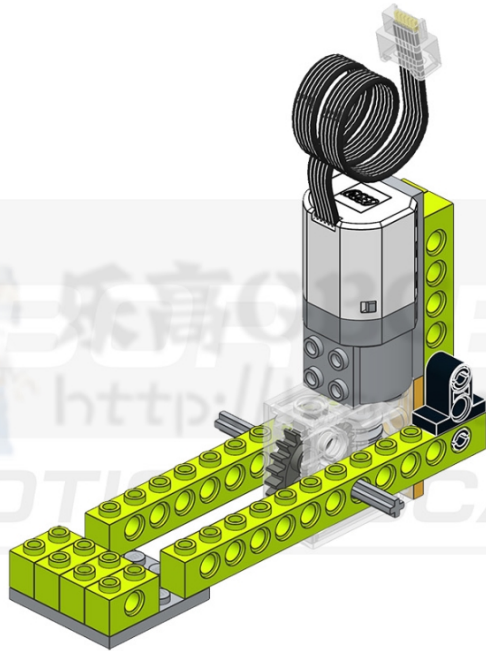

ROBO高 E-IT!
<http://reborc.com>
ROBOTICS EDUCATION

3

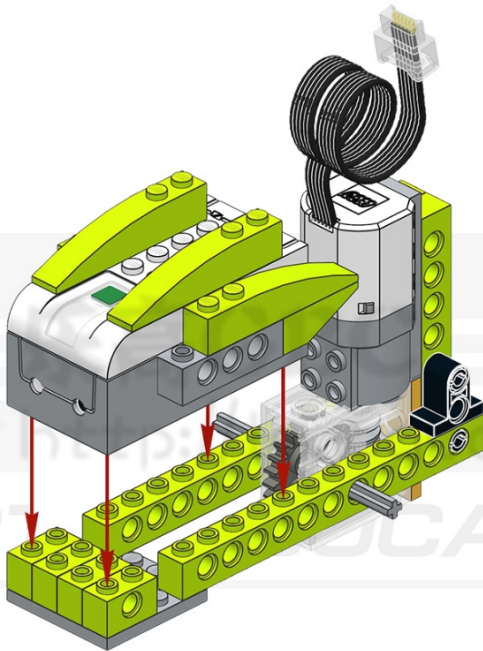
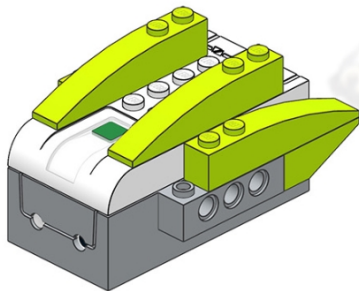

11

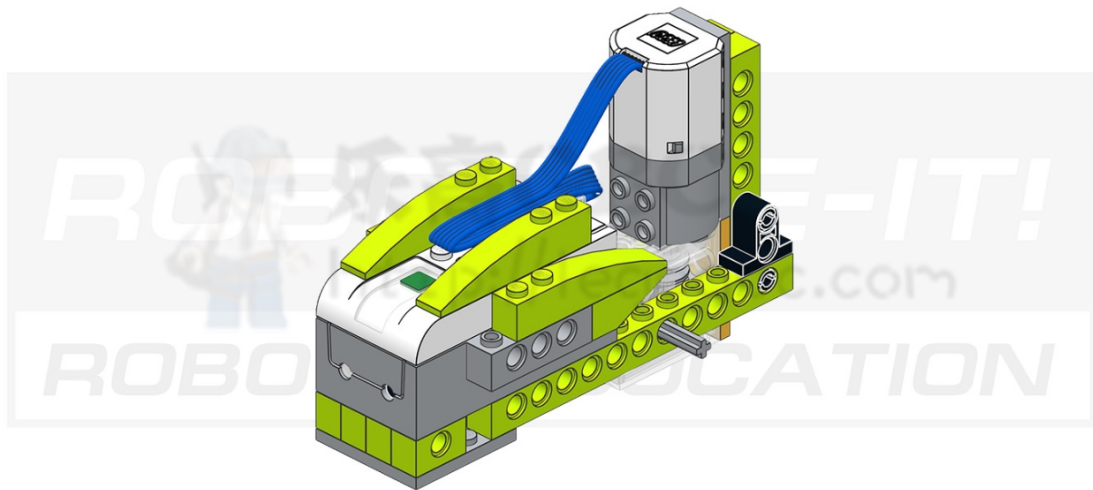

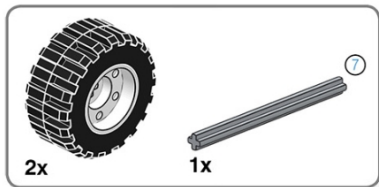

12

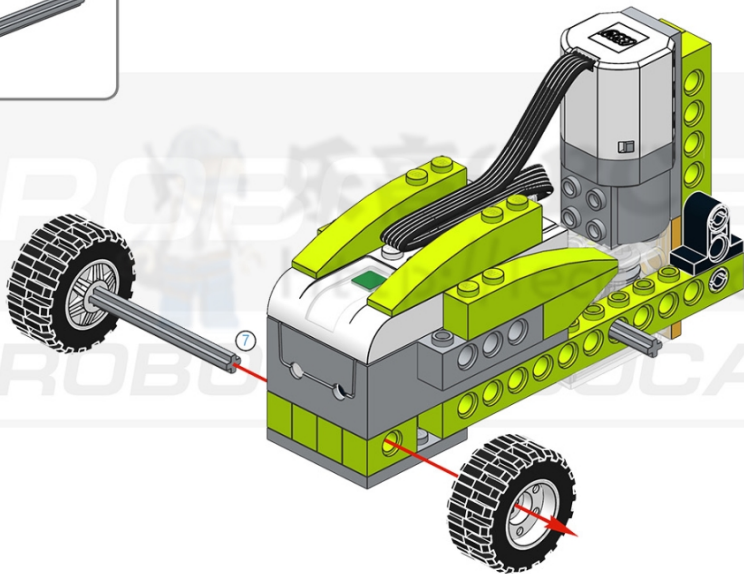



13

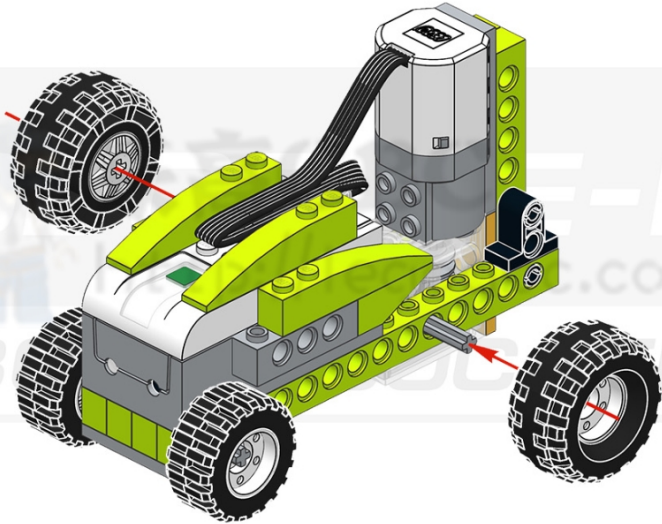

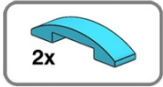

14

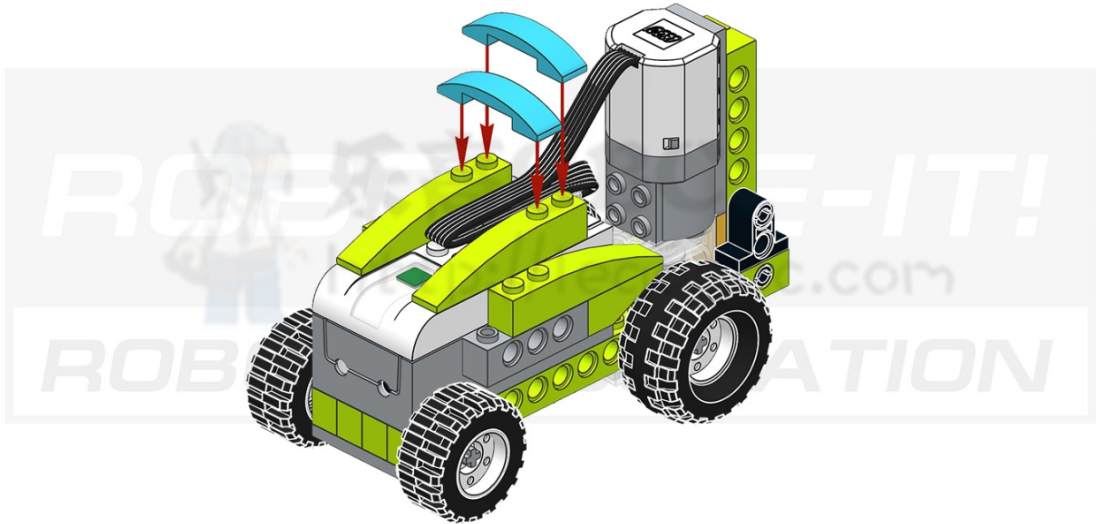

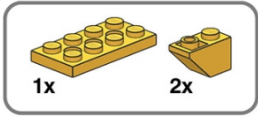

1

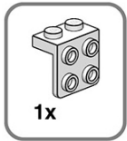
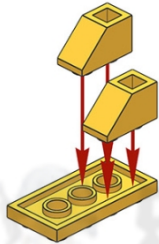

2

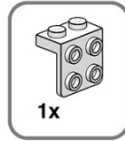
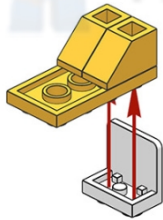

3

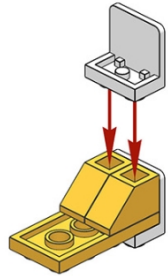

4

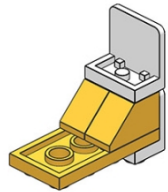

16

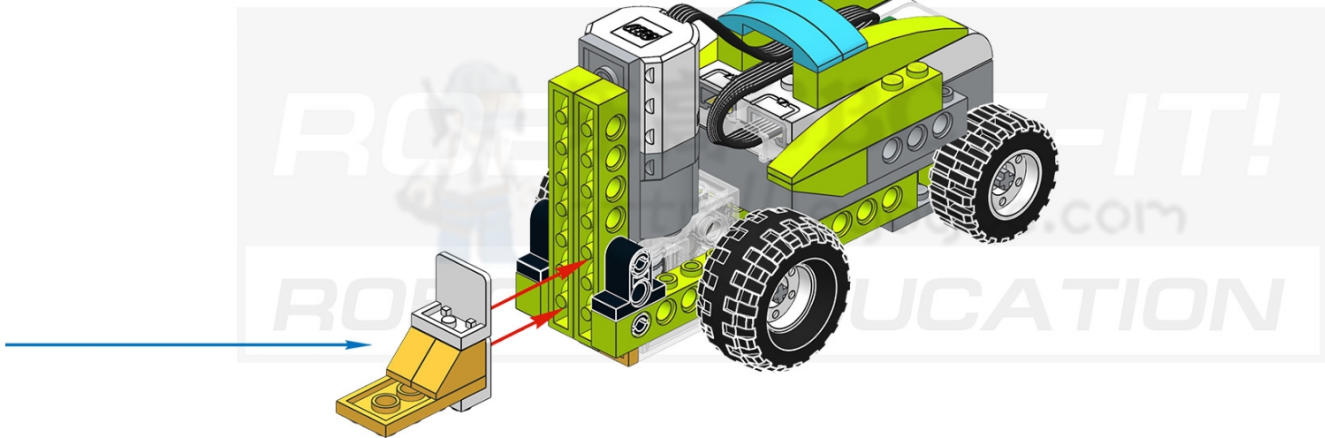

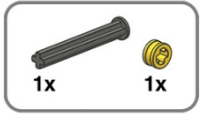

17

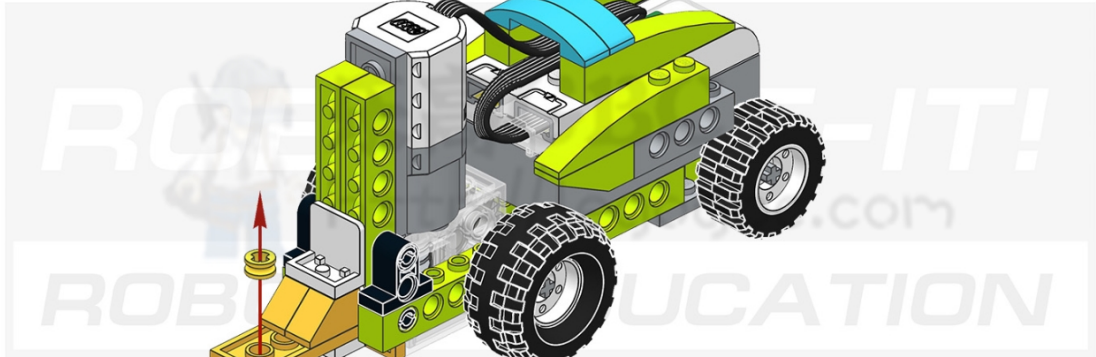

18

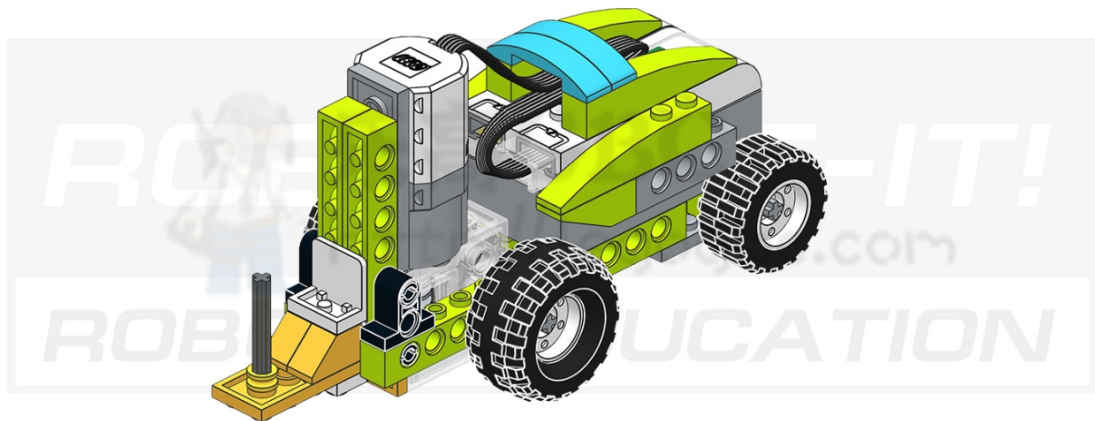



Trailer



Build a trailer



Go to the first slide of
the instruction

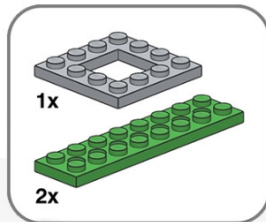
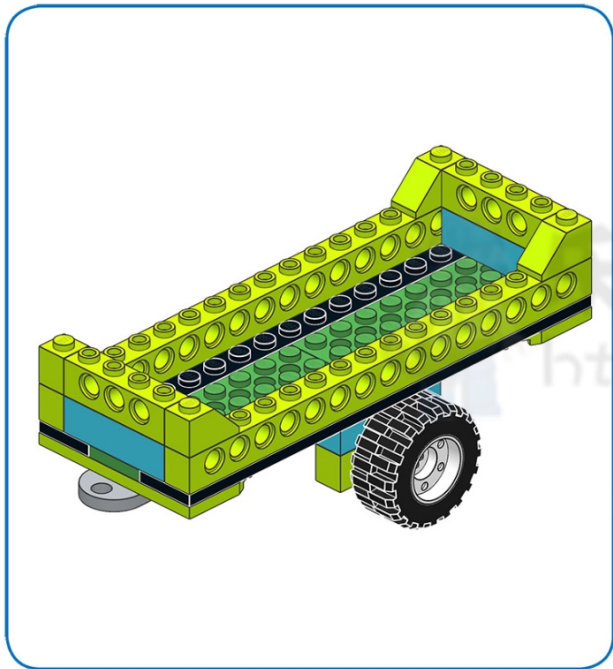

19

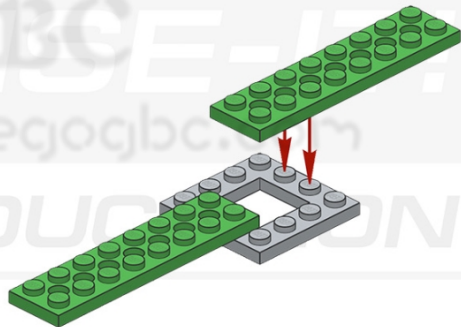

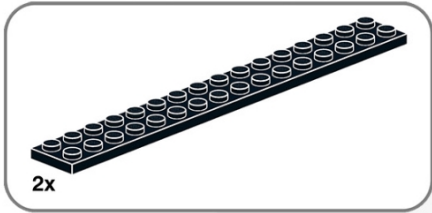

20

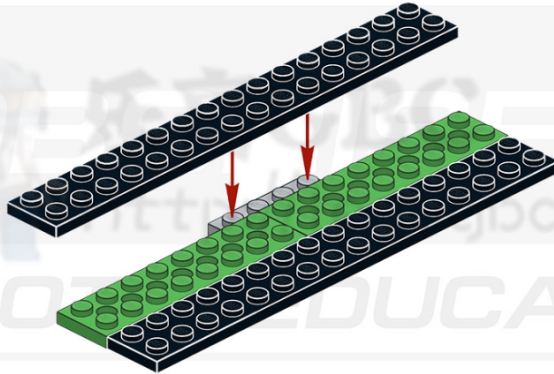

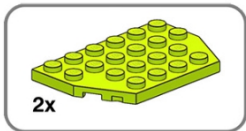

21

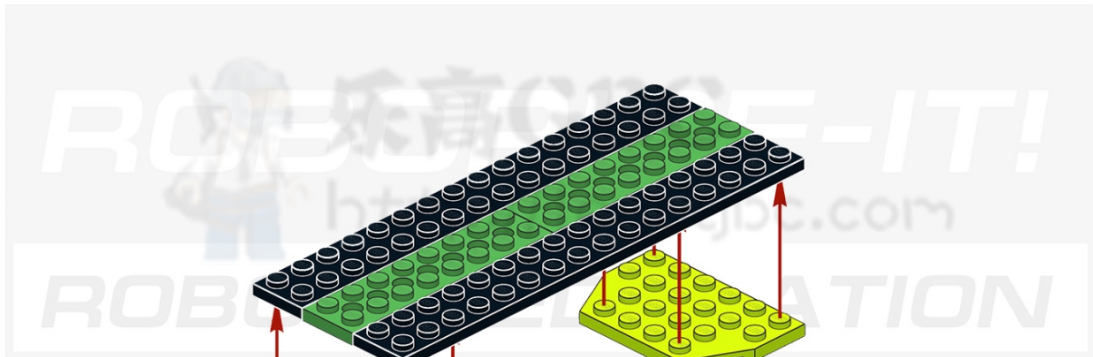

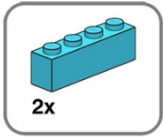

22

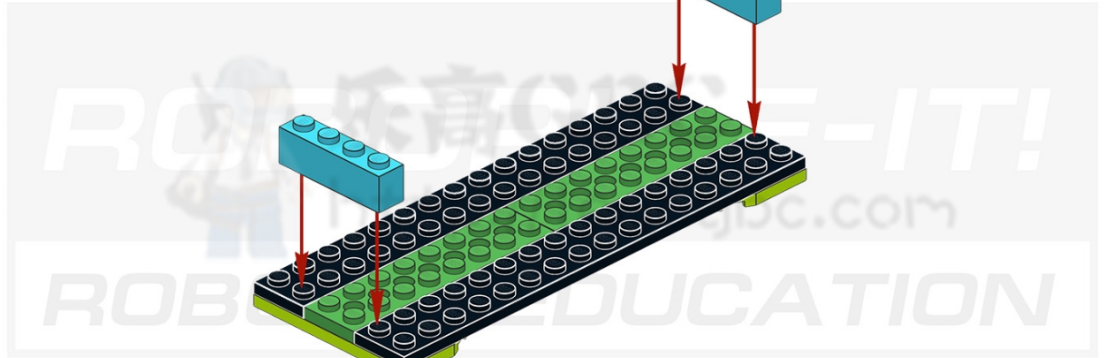

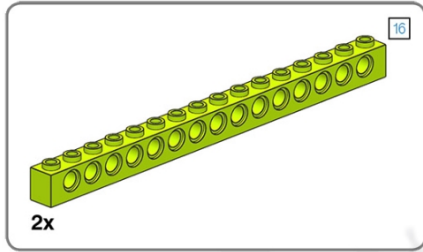

23

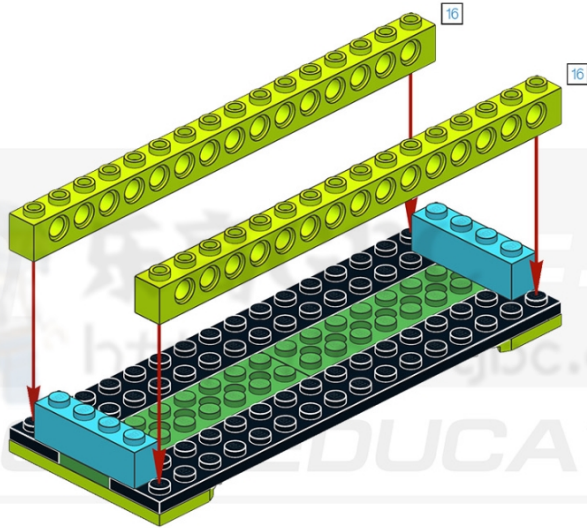

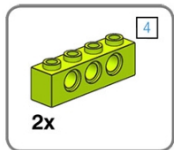

24

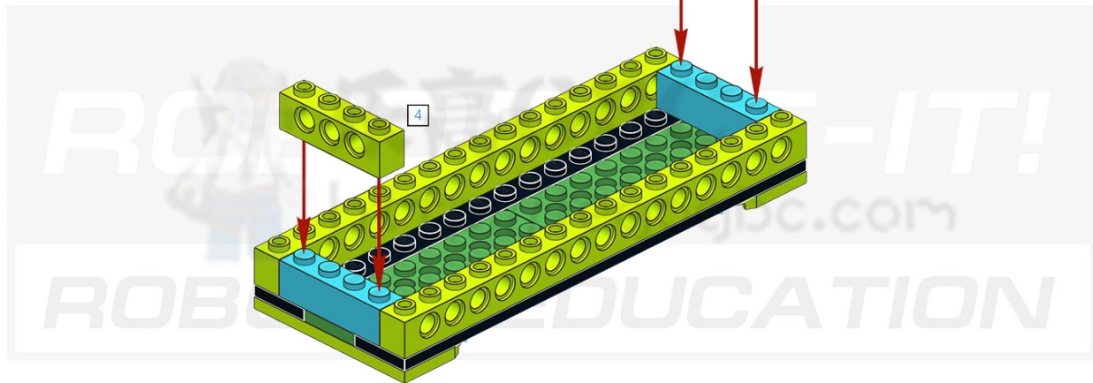



25

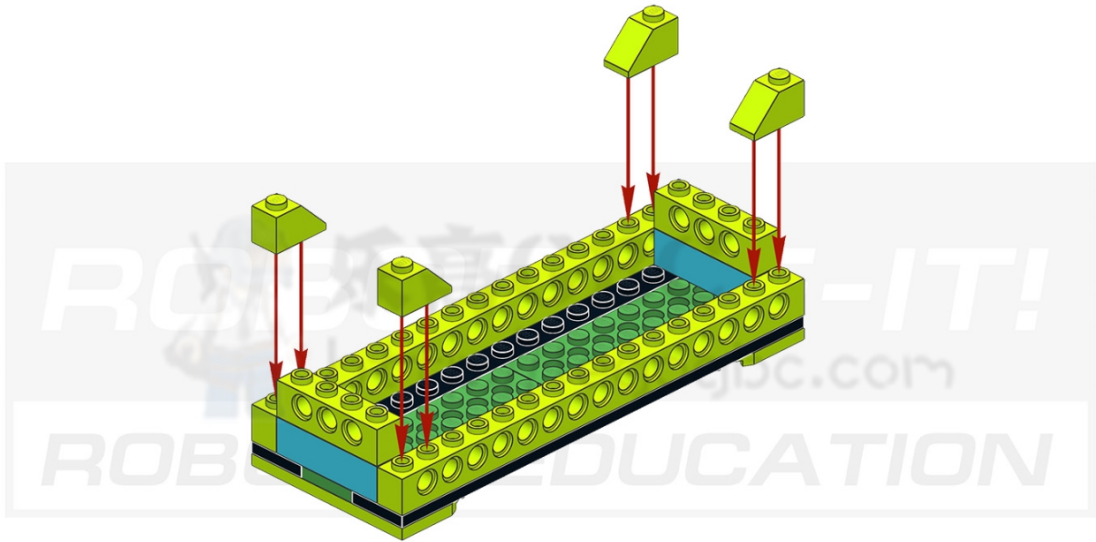

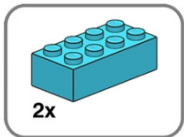

26

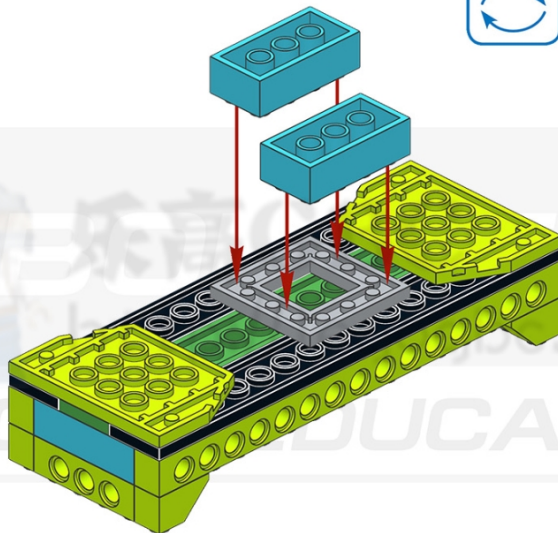

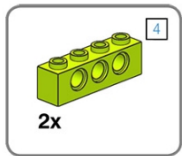

27

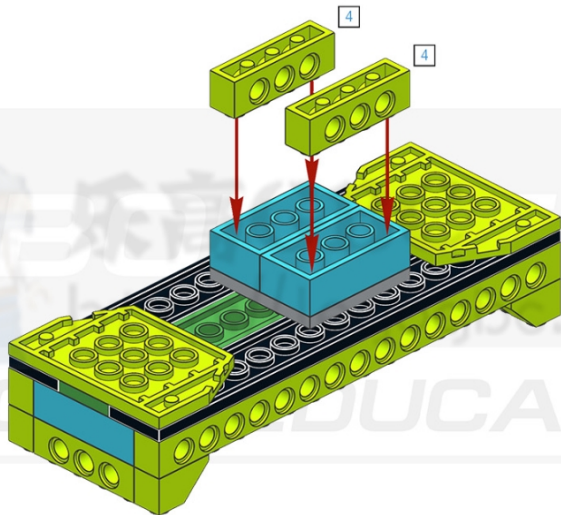

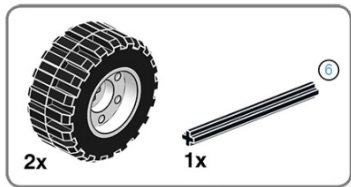

28

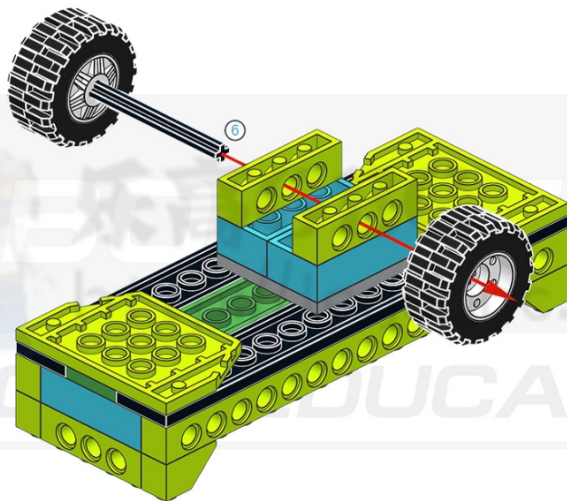

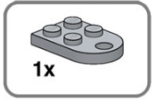

29

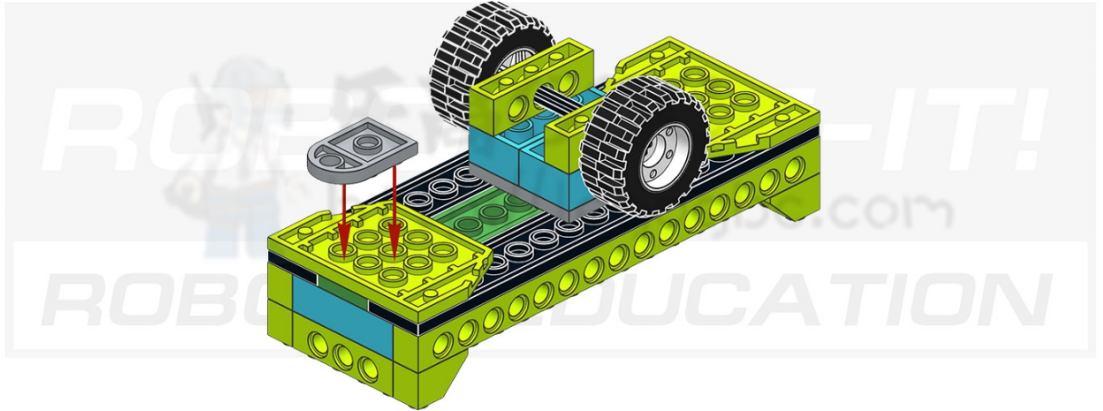

30

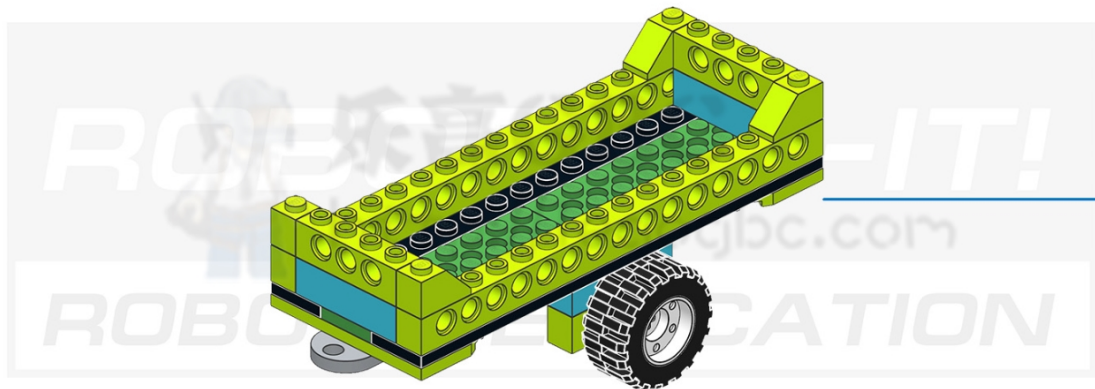

31

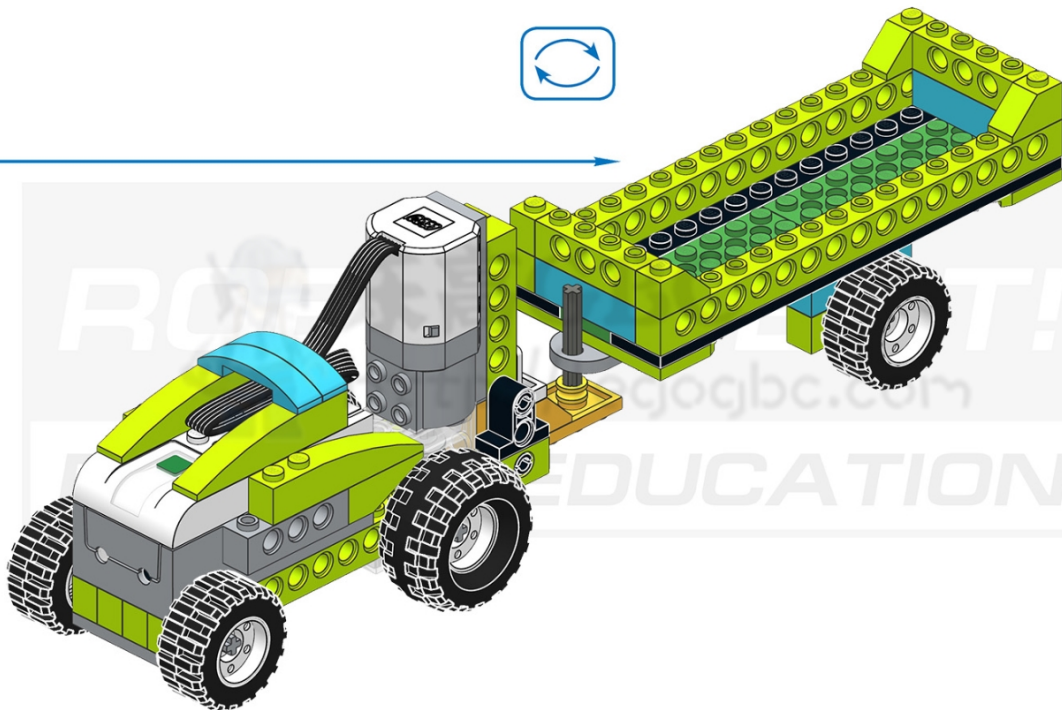

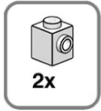

32

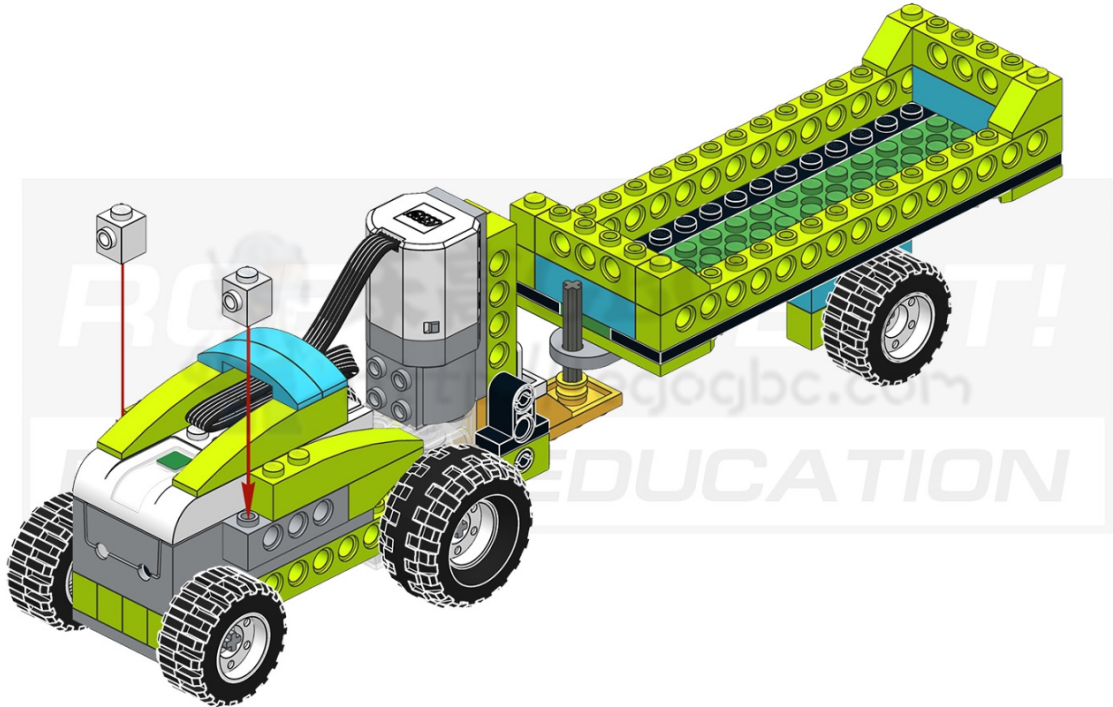



33

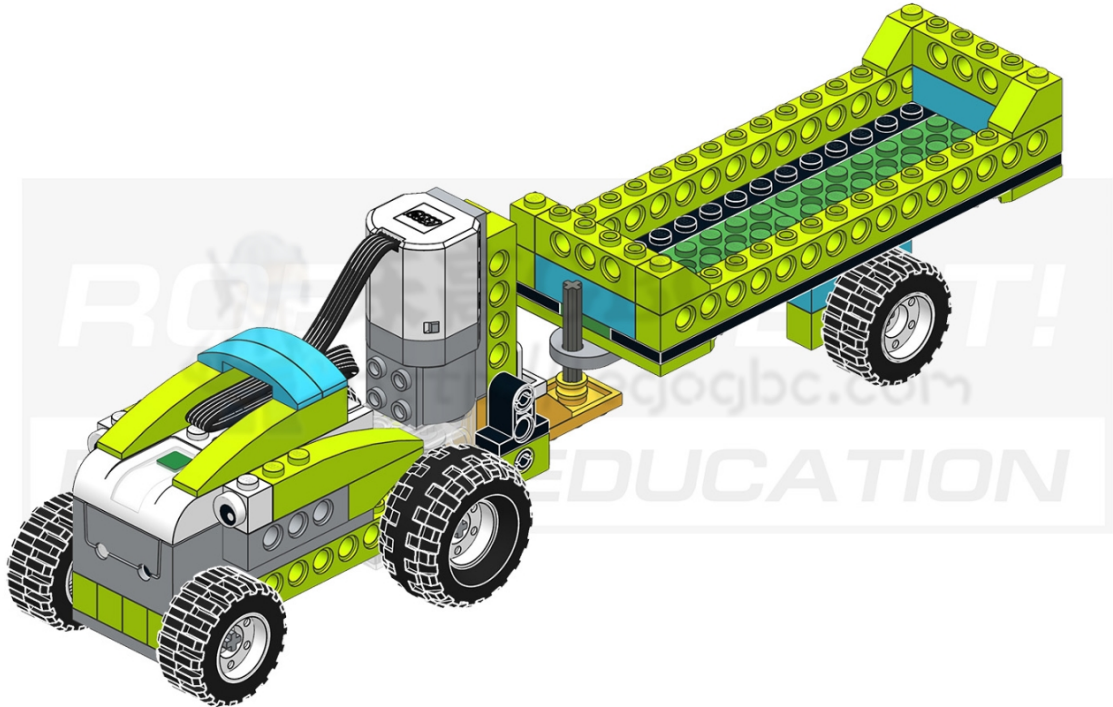



Note!



The cables must not rub while the robot is moving!





Tasks

Place the robot parts in the correct places





Task 1



Program the robot to move forward and test the transmission.





Task 1. Program



Scratch



WeDo Software



To check the movement of the robot, you can use the following program:
In the Scratch 3.0 programming environment, the program looks like this:





Task 1. Program



Scratch



WeDo Software



To check the movement of the robot, you can use the following program:

In WeDo Software, a similar program looks like this:

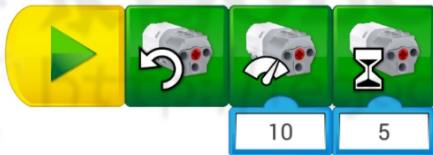



Discuss!



乐高ABC

<http://legogbc.com>

Which sensor can be used to detect obstacles in front of the robot?
Where do you need to install it to complete the task?



Task 2



Attach the motion sensor to the front of the robot.





Task 3



Program the movement of the robot to detect an obstacle.





Task 3. Program



Scratch



WeDo Software



Program the robot to move before detecting an obstacle.

In the Scratch 3.0 programming environment, the program looks like this:

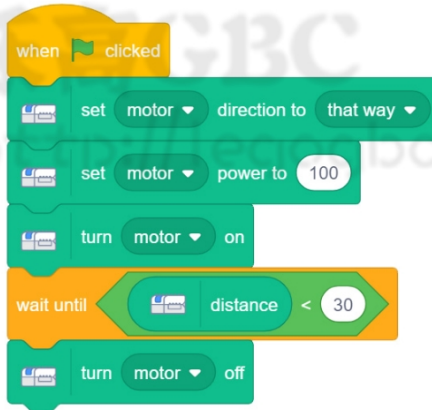



Task 3. Program



Scratch



WeDo Software



Program the robot to move before detecting an obstacle.

In WeDo Software, a similar program looks like this:

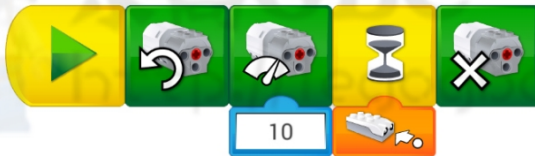



Task 4



Program the start of the robot after the command given to the motion sensor by successive zooming in and out.





Task 4. Program



Scratch



WeDo Software



Write the following program:

In the Scratch 3.0 programming environment, the program looks like this:

```
when green flag clicked
  set motor direction to that way
  set motor power to 100
  wait until distance < 30
  wait until distance > 50
  turn motor on
  wait until distance < 30
  turn motor off
```



Task 4. Program



Scratch



WeDo Software



Write the following program:

In WeDo Software, a similar program looks like this:





Task 5 *



Use the illumination of the SmartHub button to indicate the mode of operation of the robot: green for forward movement and red for stopping.





Question



Which wheel of the images below creates less pressure on the surface?





Question



How many times has the power increased when using such a worm gear?

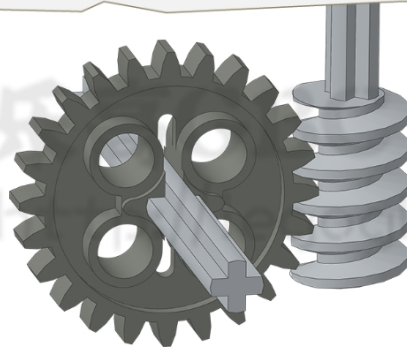

2

4

24



Question



Scratch



WeDo Software



Which of the waiting blocks shown will skip program execution when the motion sensor data is increased?



```
when clicked
  set motor direction to that way
  set motor power to 100
  wait until distance < 30
  wait until distance > 50
  turn motor on
  wait until distance < 30
  turn motor off
```



Question



Scratch



WeDo Software



Which of the waiting blocks shown will skip program execution when the motion sensor data is increased?





Discuss!

- Why are tractors called universal machines?
- How can tractors move on soft surfaces?
- What kind of robot design update did you make?
- What additional functions of the robot have you programmed?
- How can a tractor carry huge loads when equipped with a small motor?





Your achievements

Total:

0



1



2



3



4

