

1

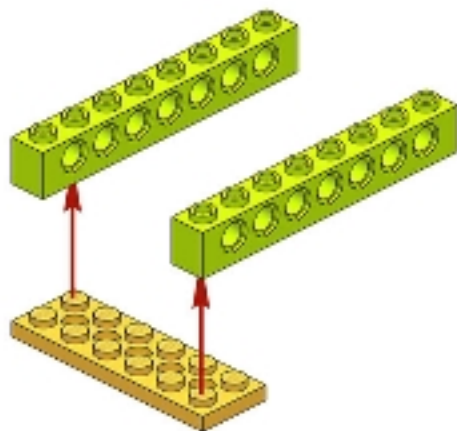

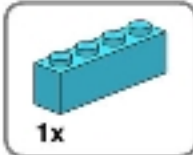

2

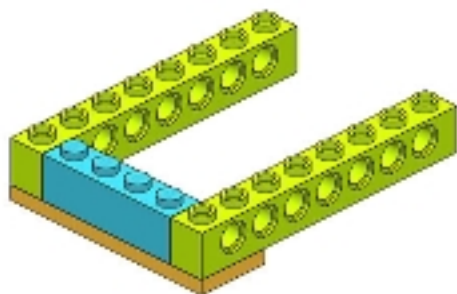



1x

2x

3

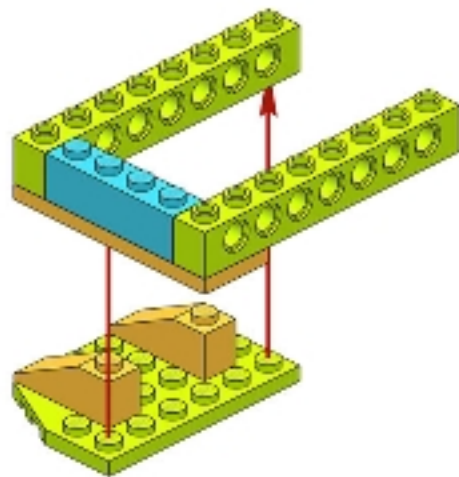

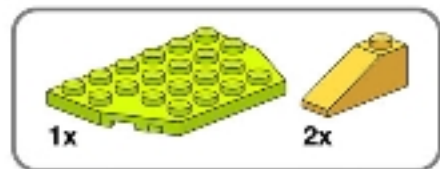

4

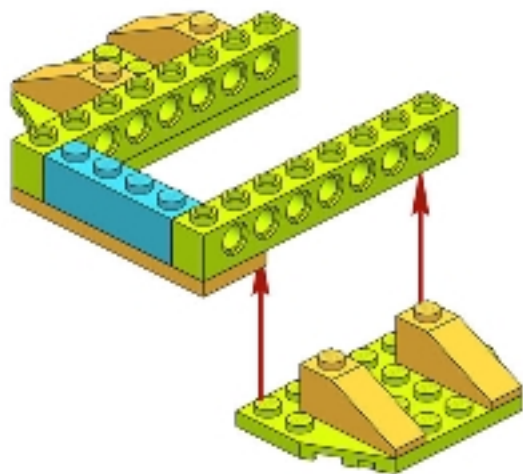

5

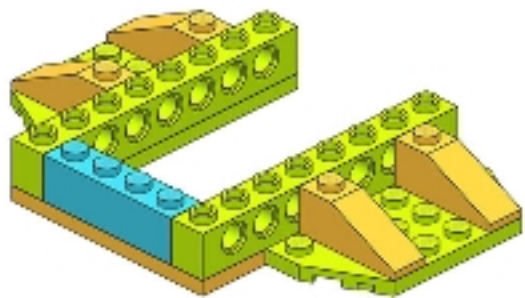



2x

6

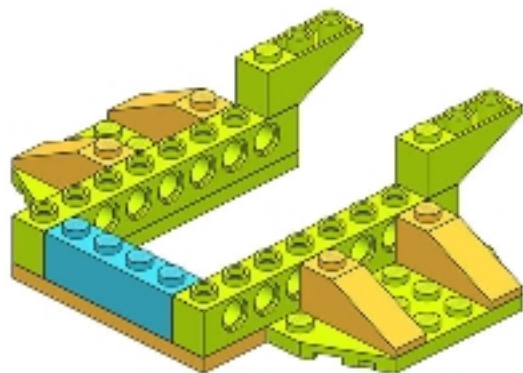

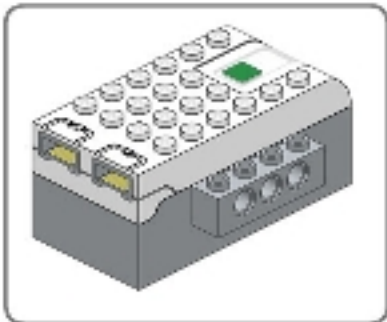

7

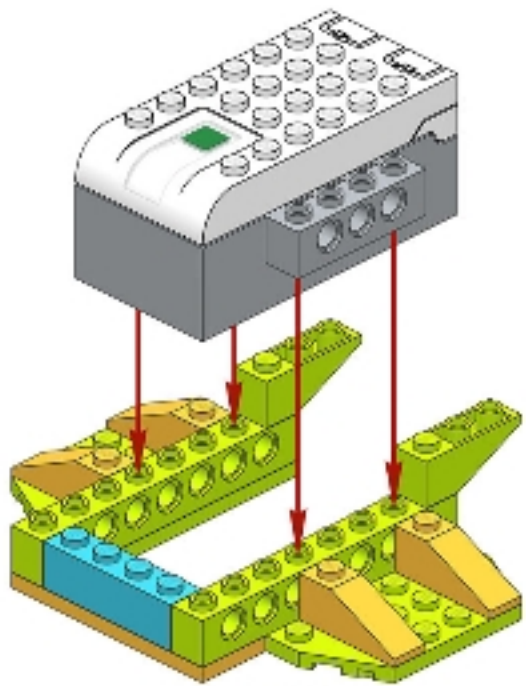

8

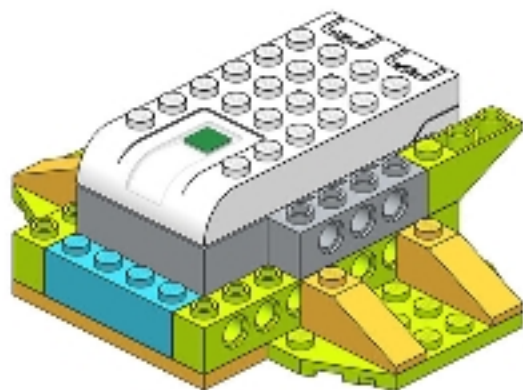



1x



1x

9

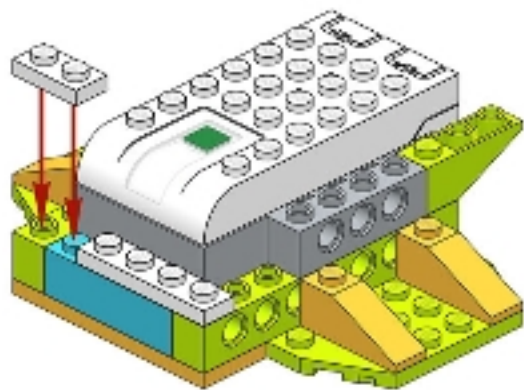



2x

10

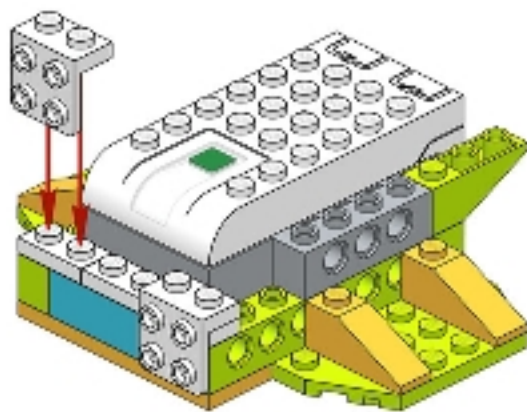

11

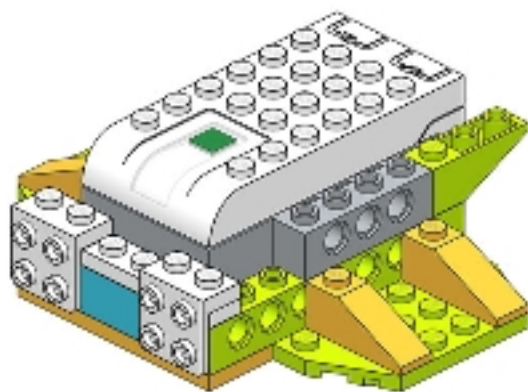



2x

12

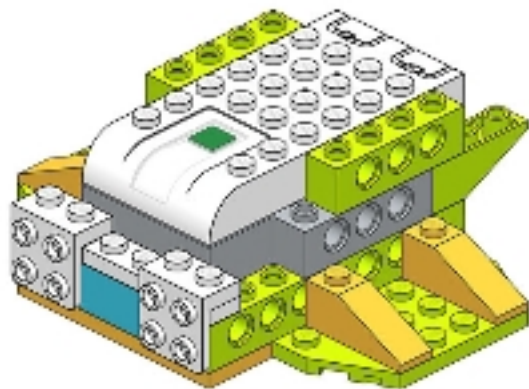



2x

13

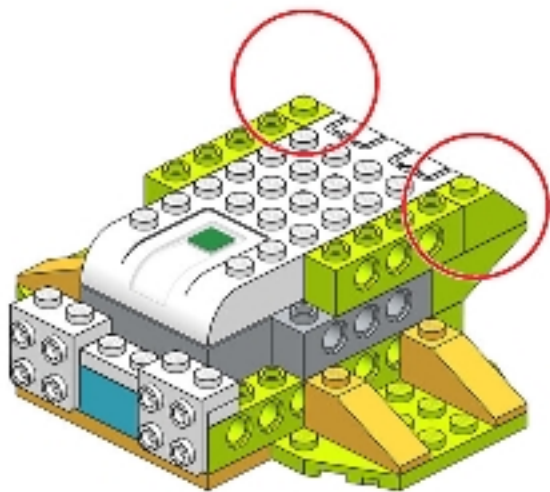



2x



1x

14

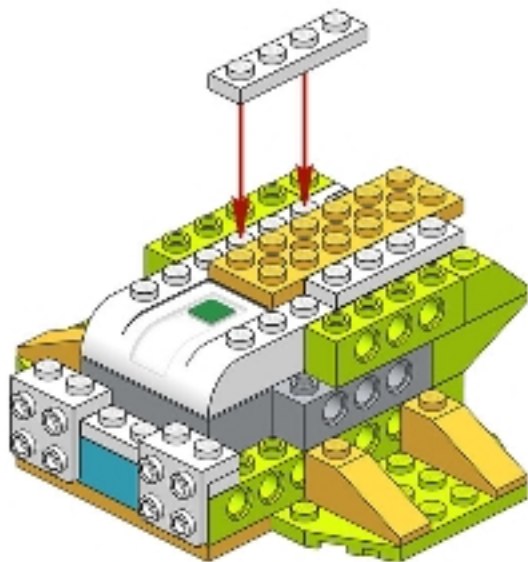



1x



1x

15

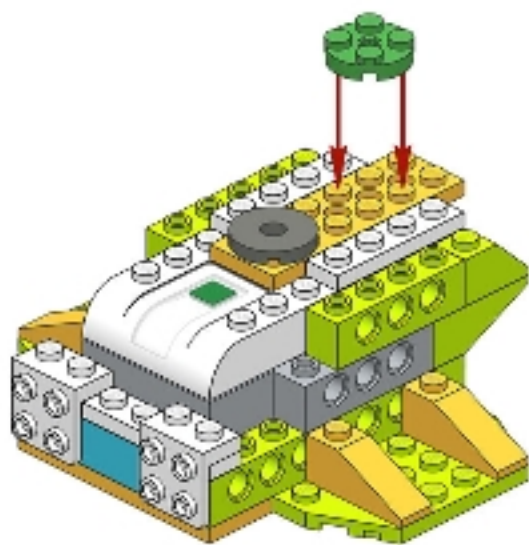

16

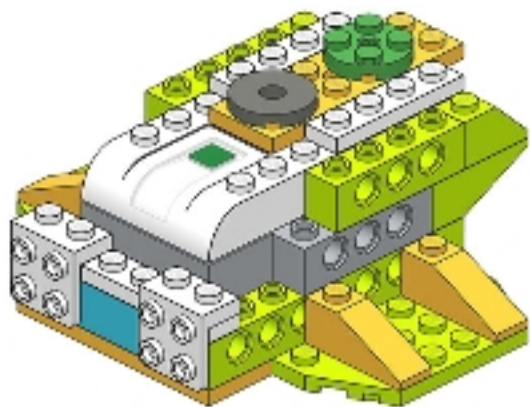

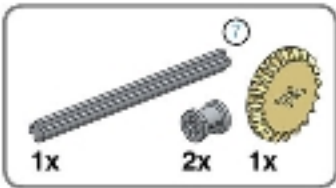

18

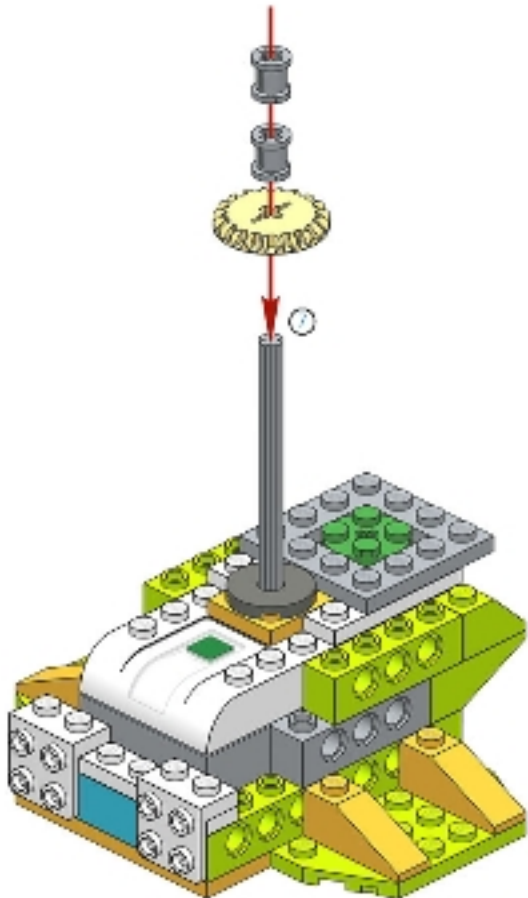

19

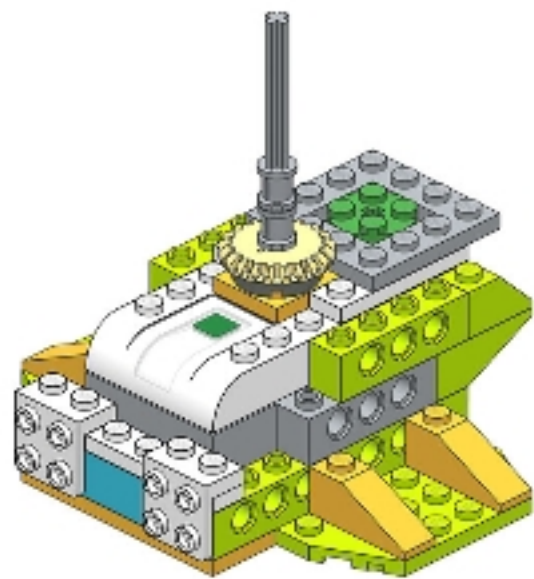

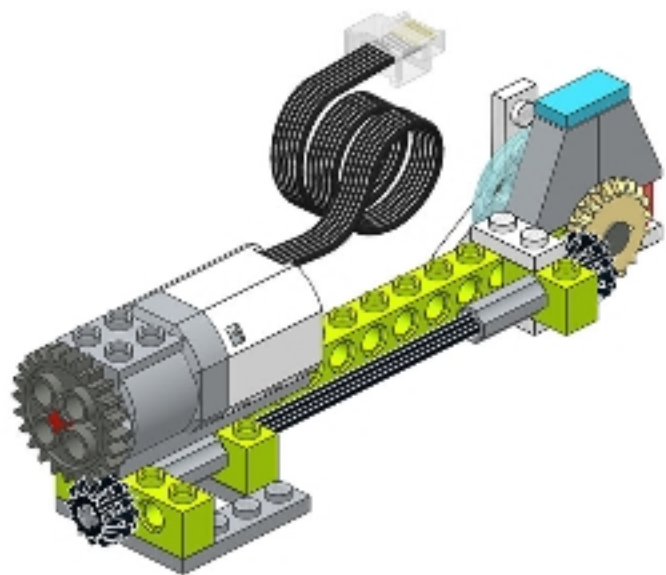

1x



1x

20

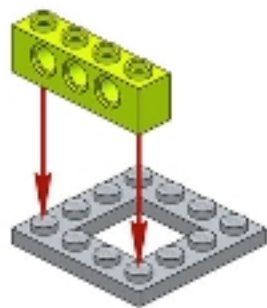

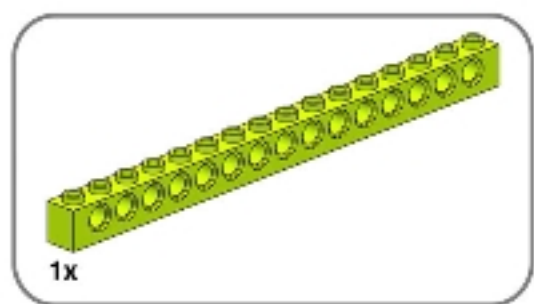

21

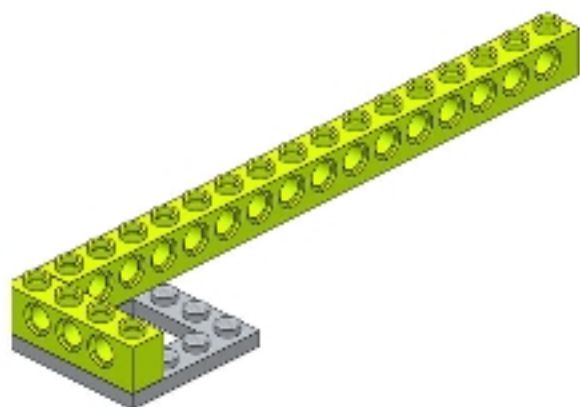



1x



1x

22

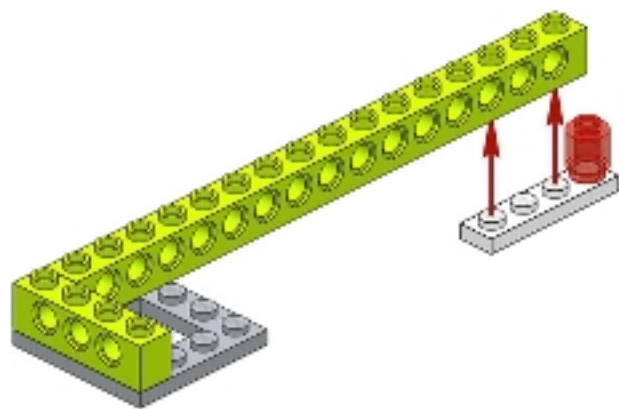



1x

23

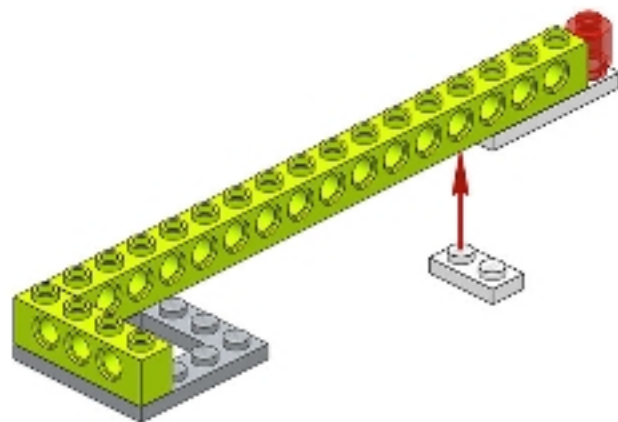

24

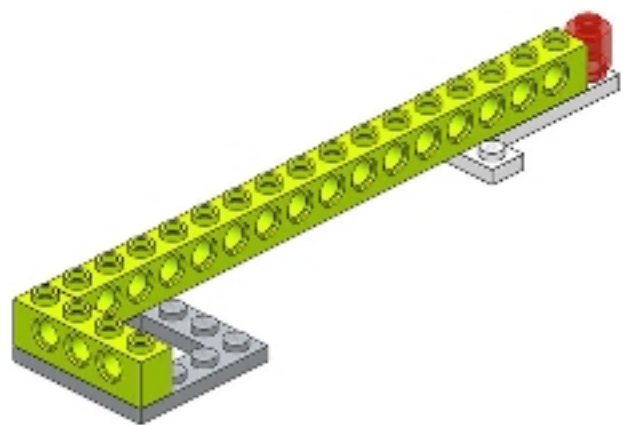



1x



1x

25

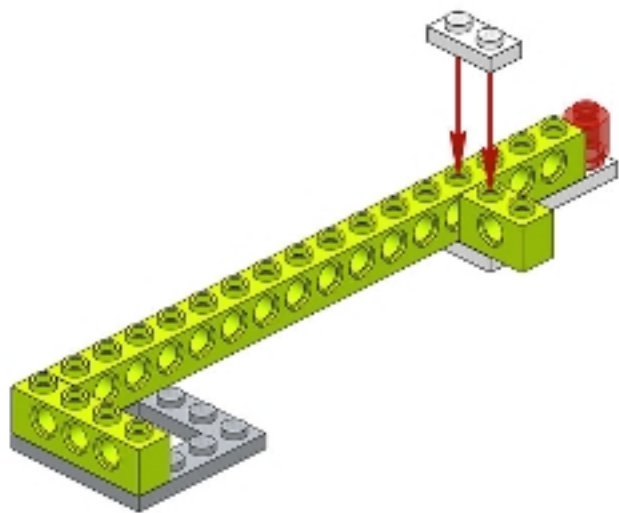

26

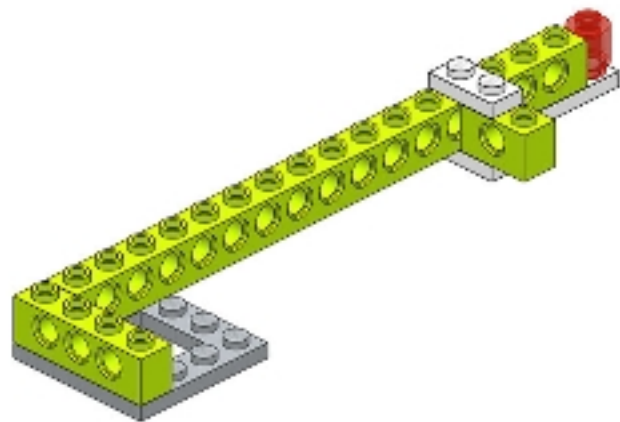

28

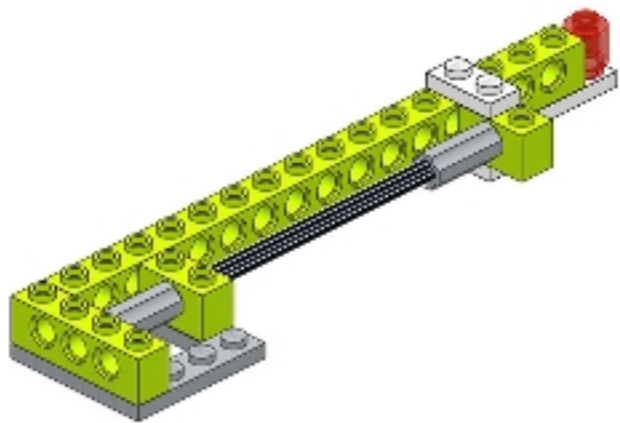

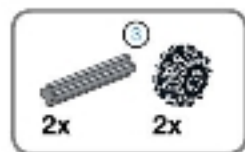

29

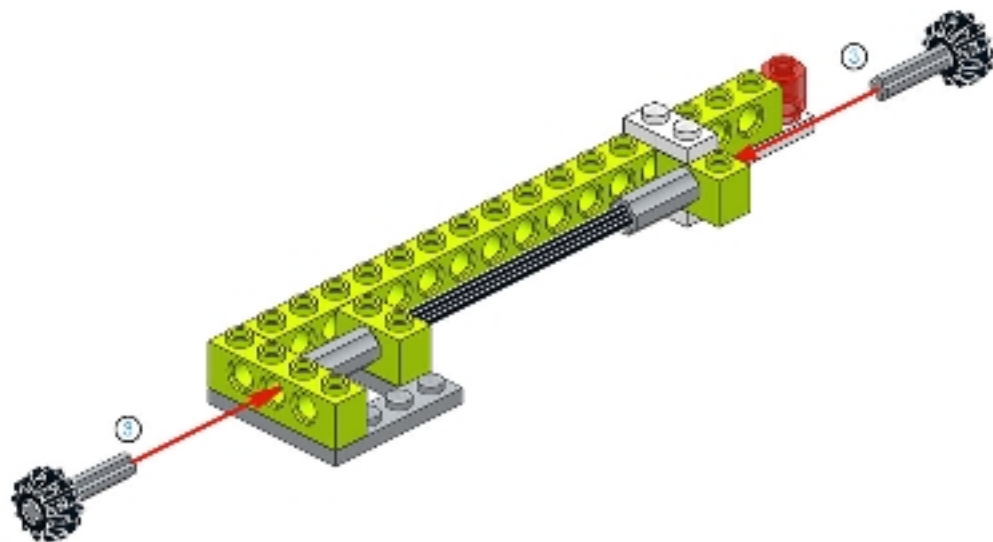

30

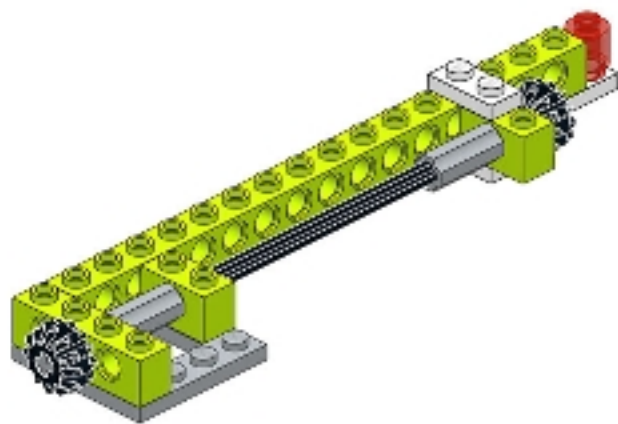

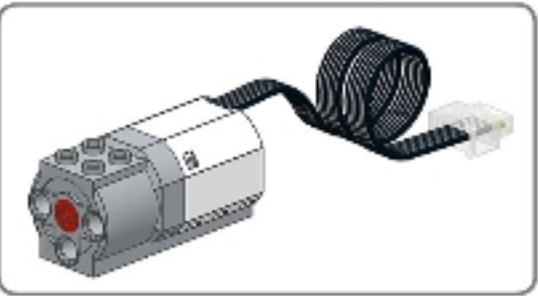

31

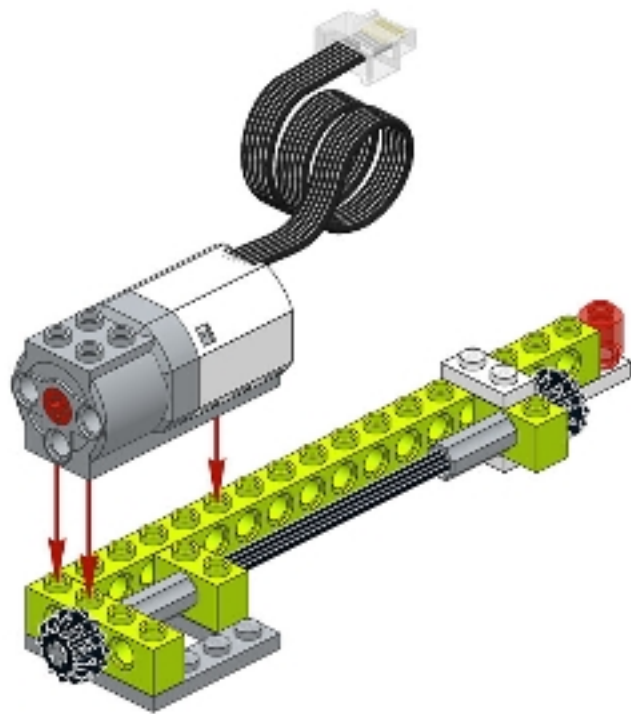

32

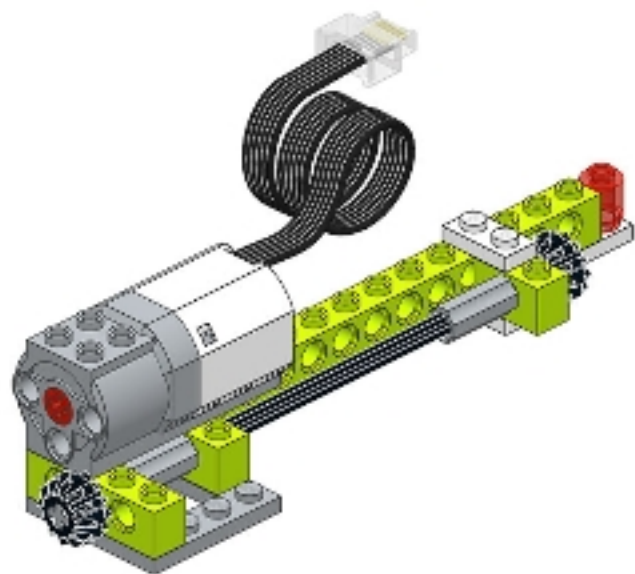

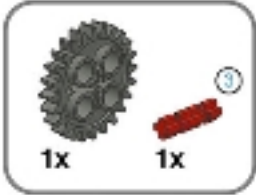

33

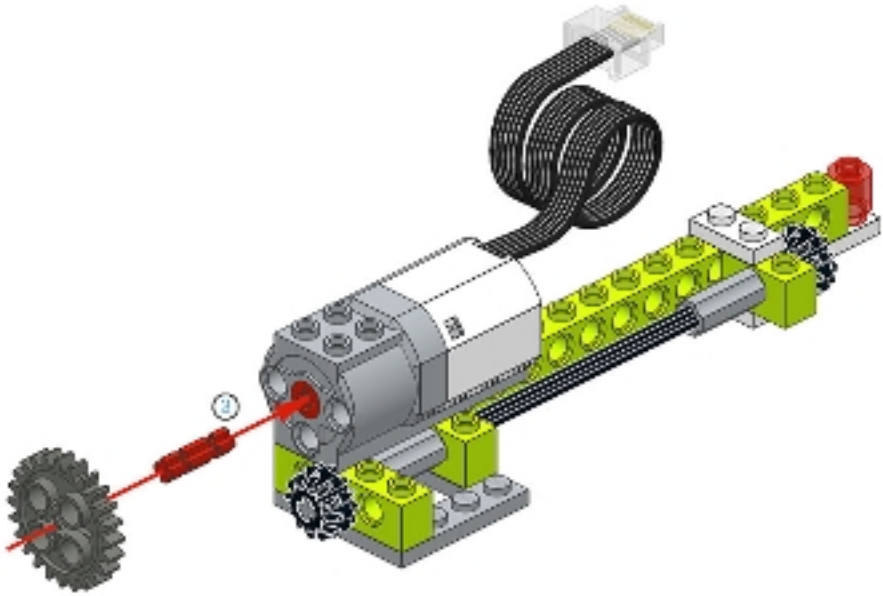

34

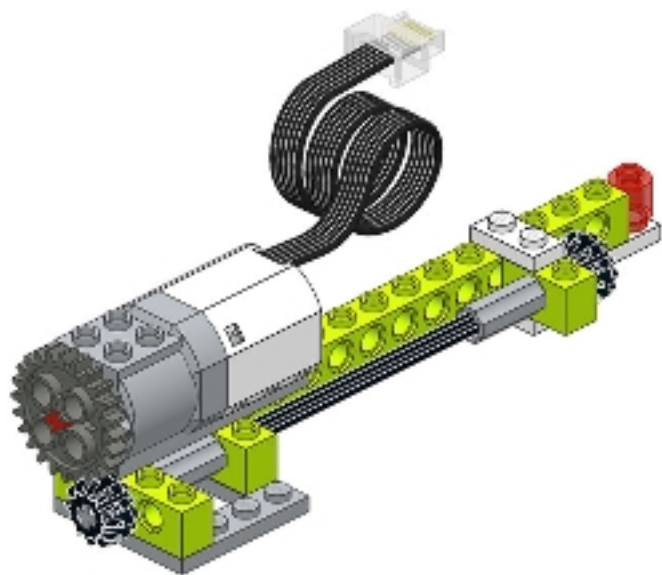

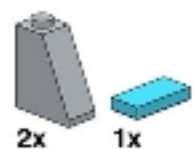

35

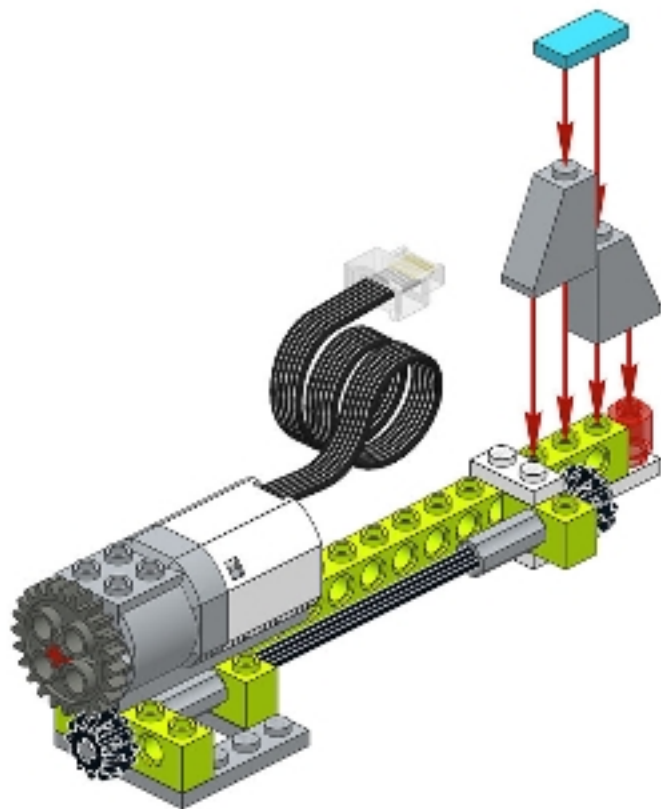

36

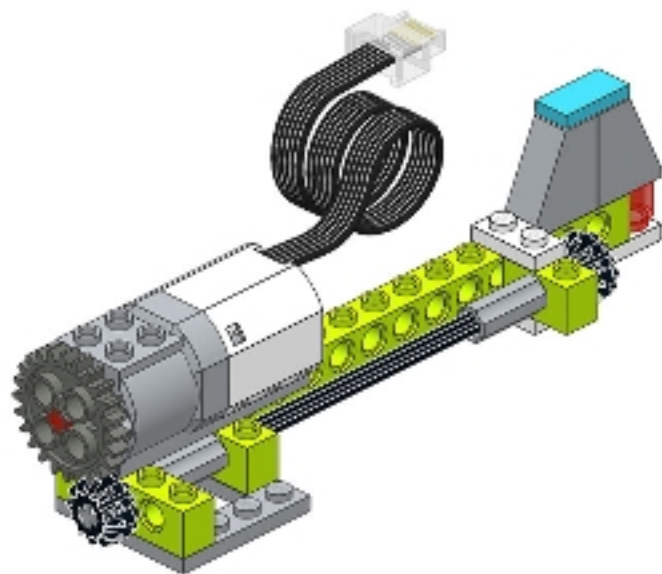

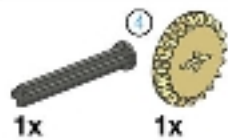

37

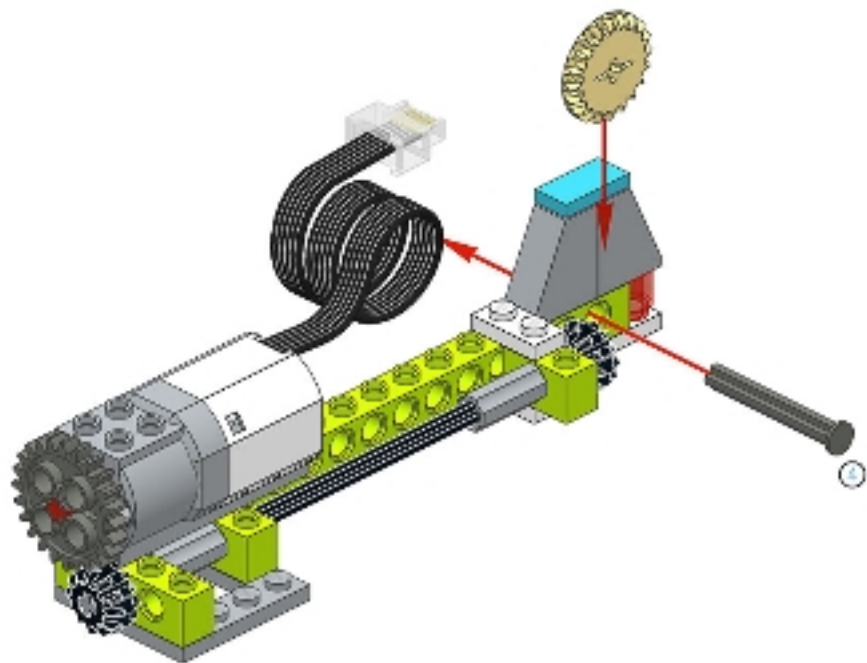

38

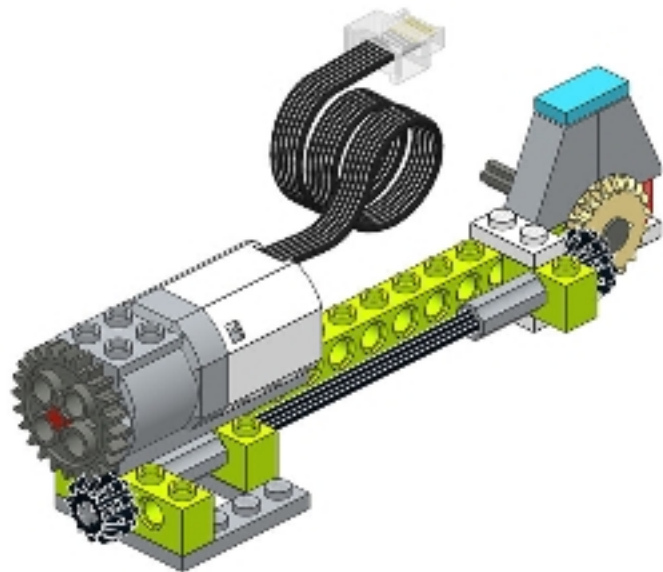



1x



39

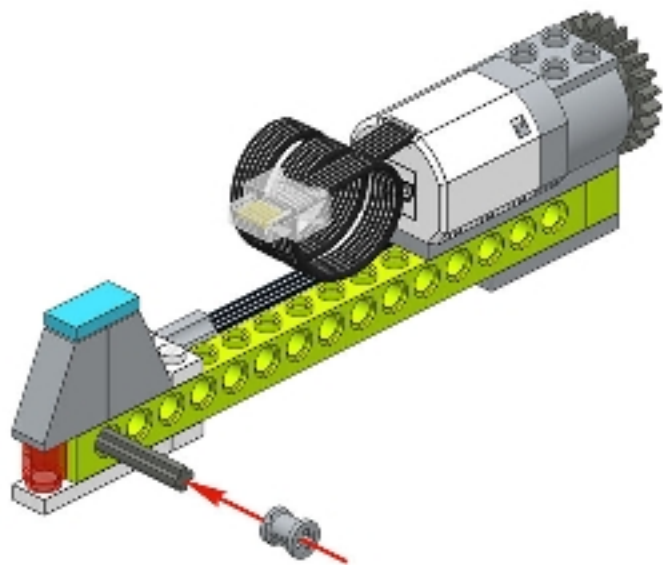

42

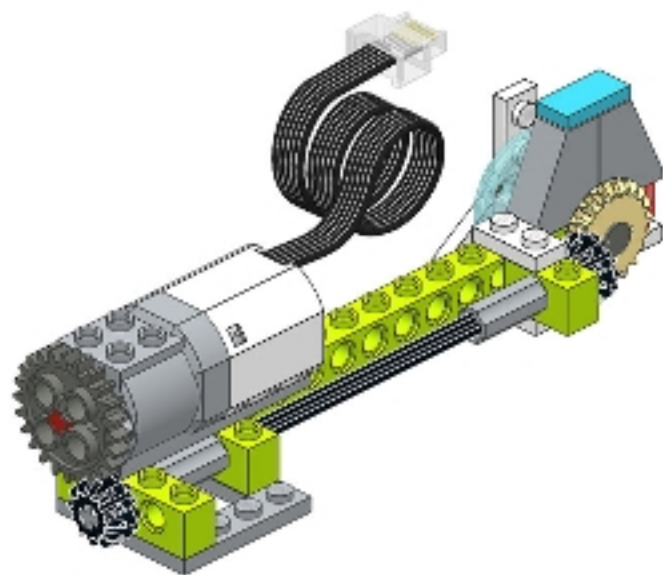

43

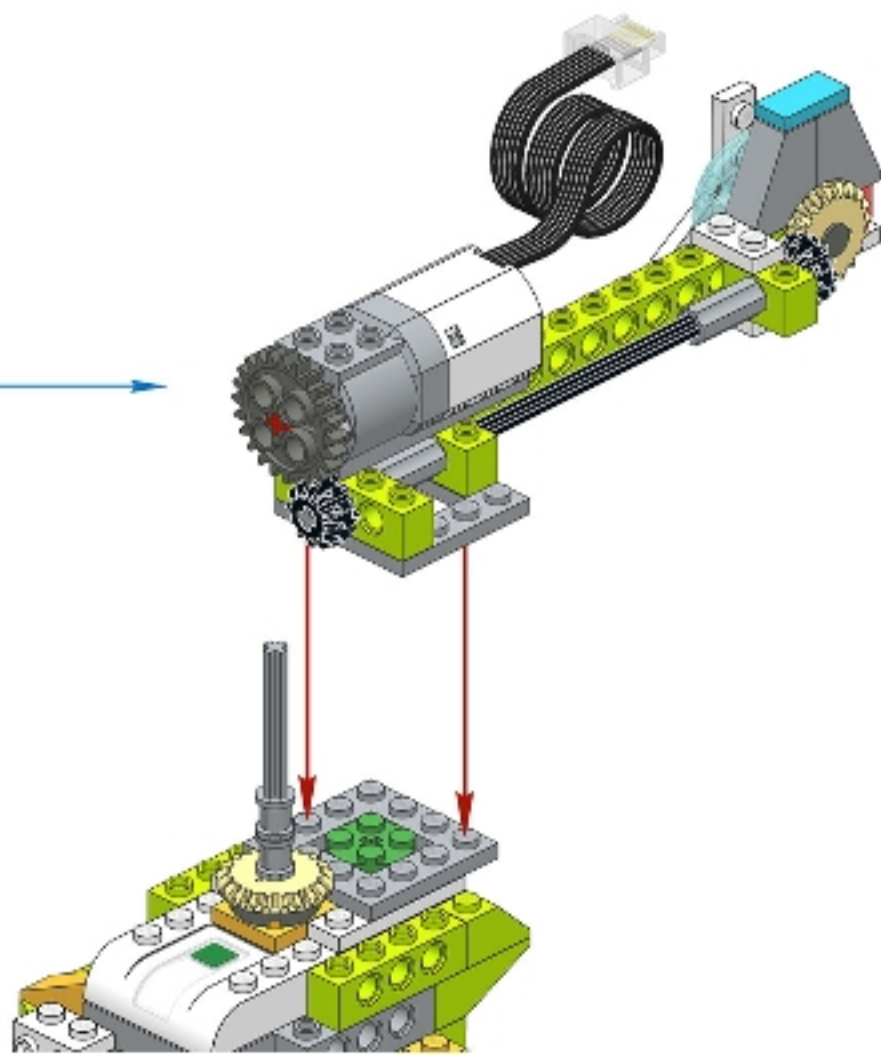

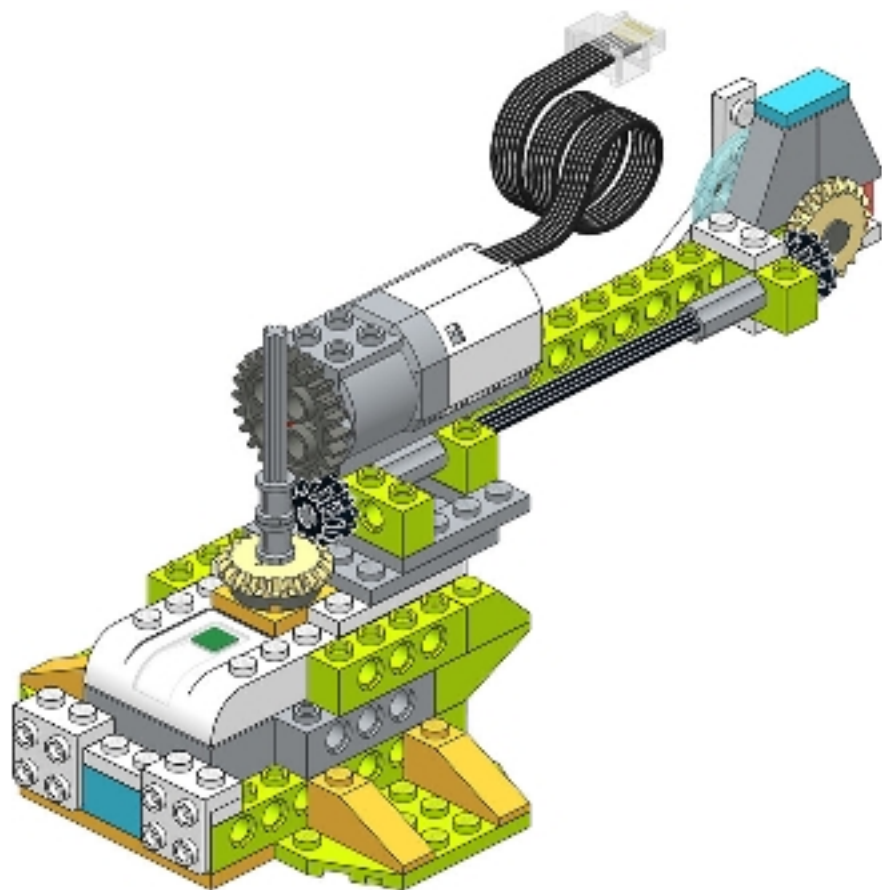

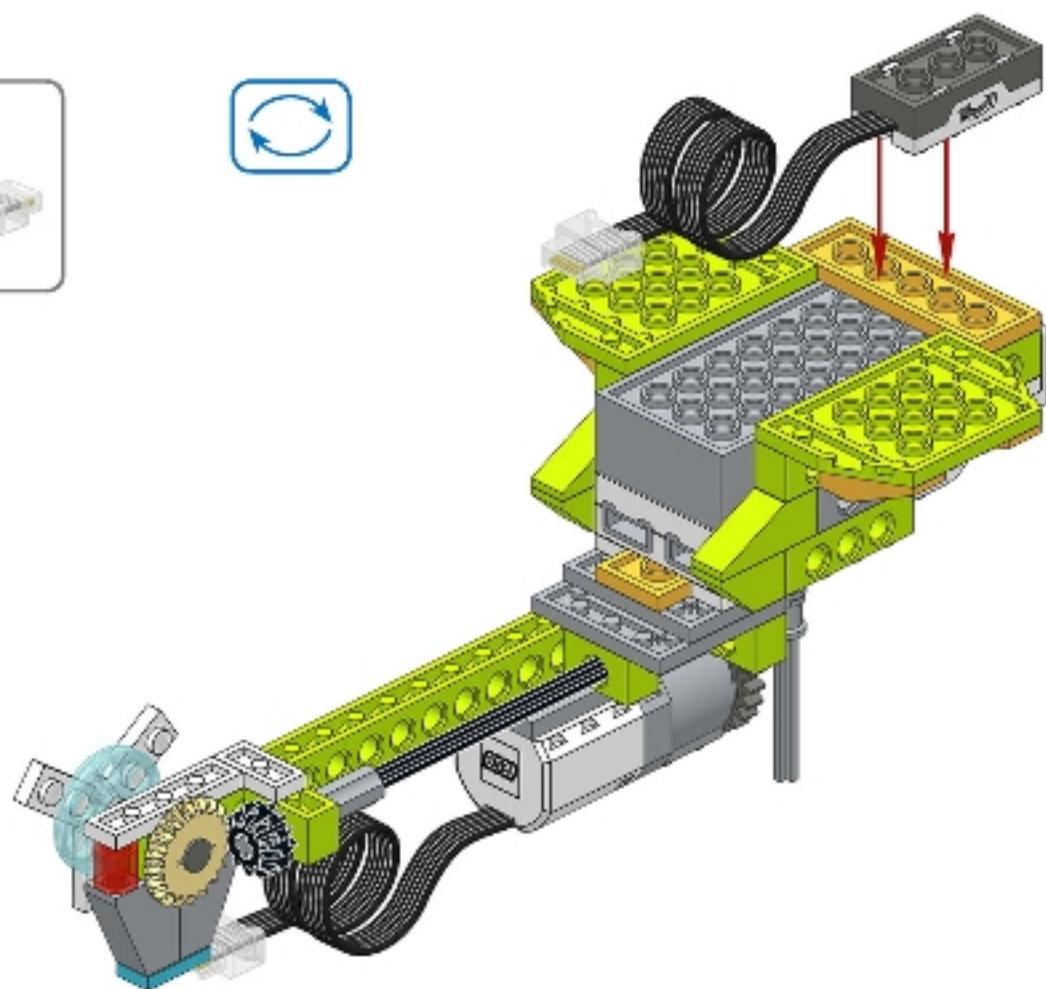
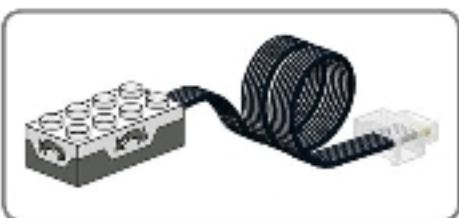

45

46

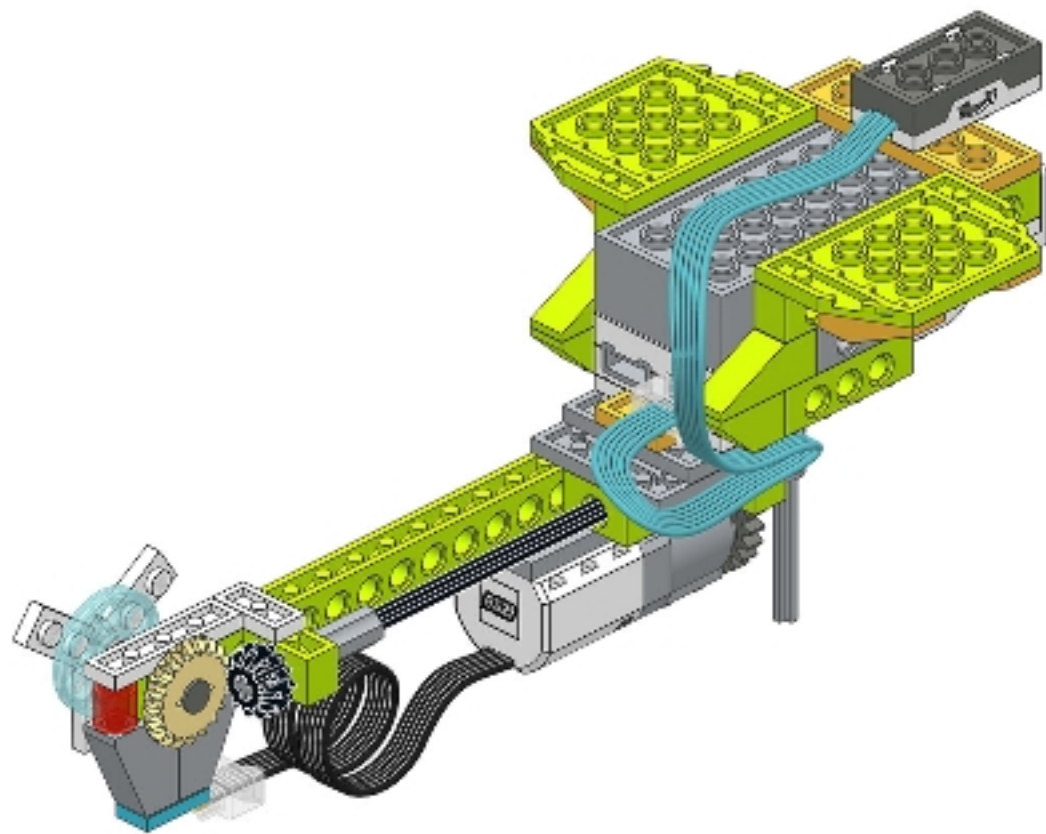

47

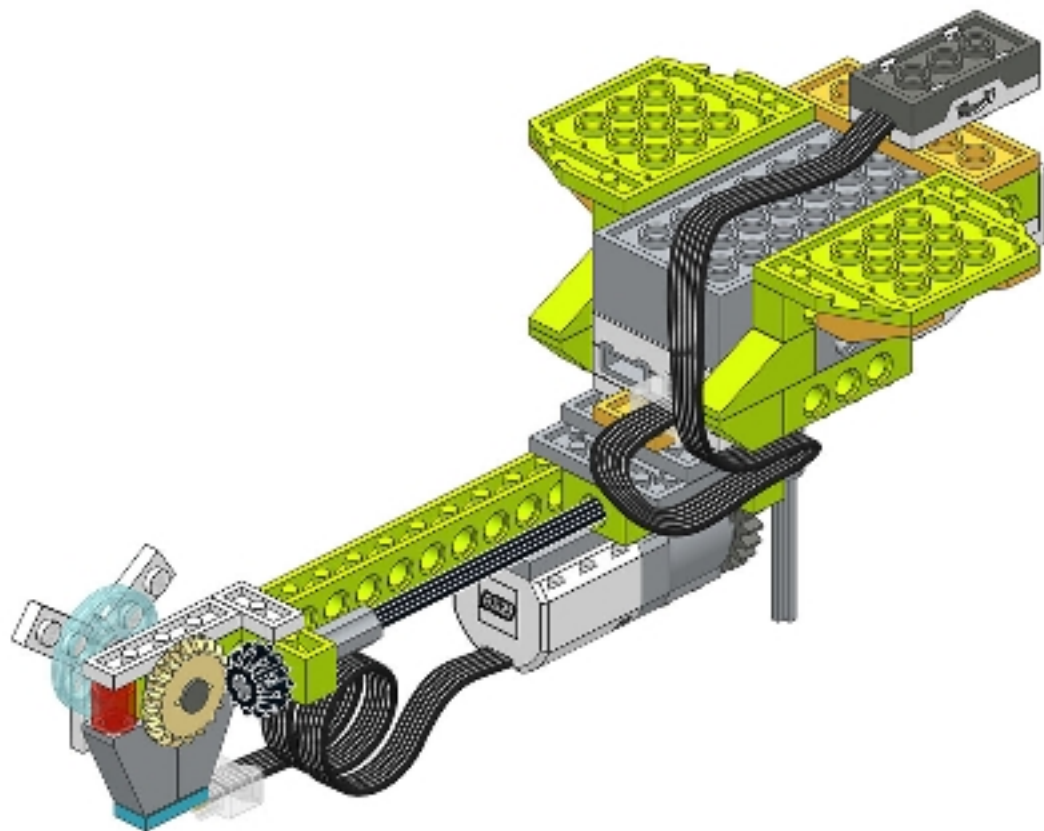

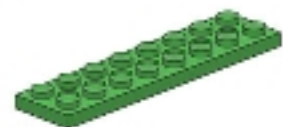

2x

48

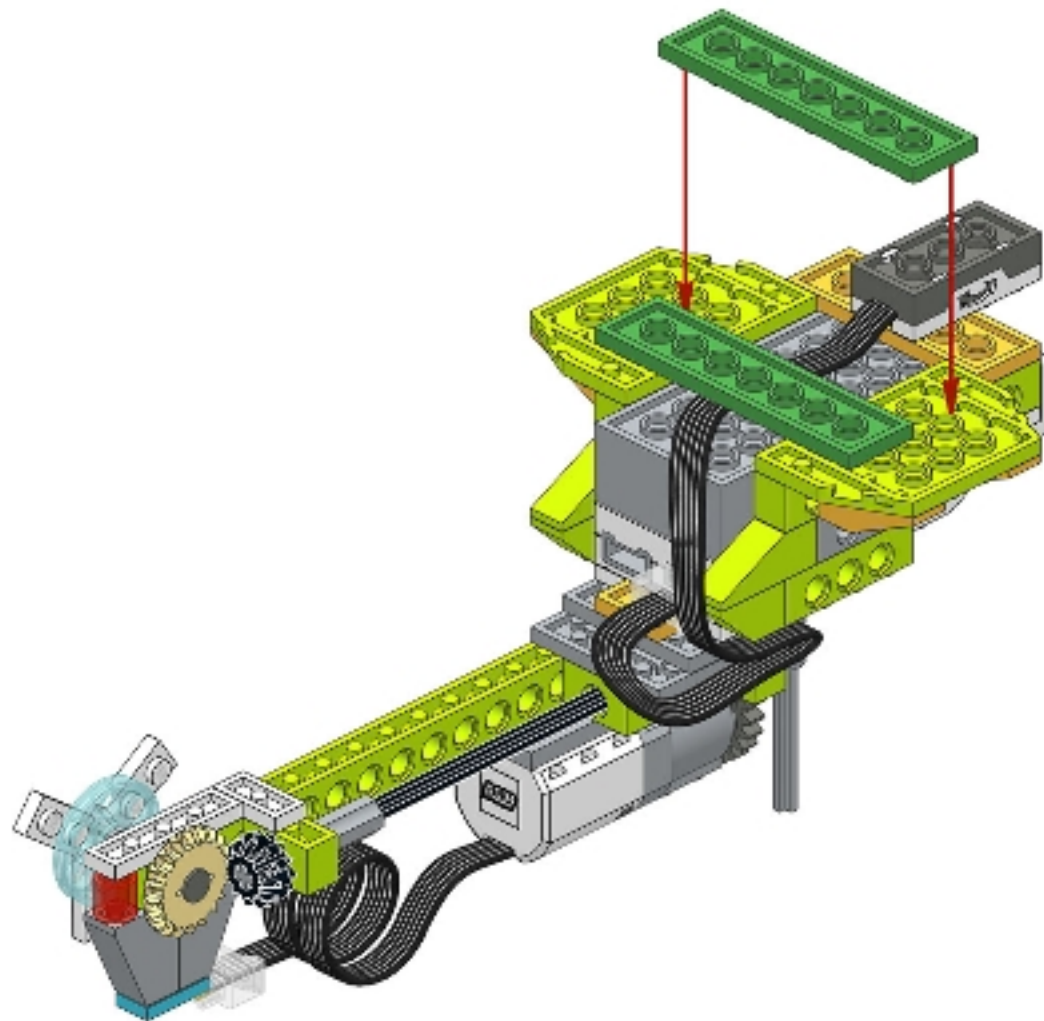

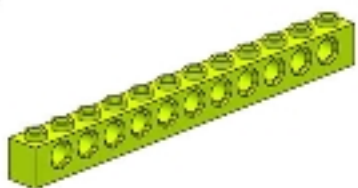

2x

49

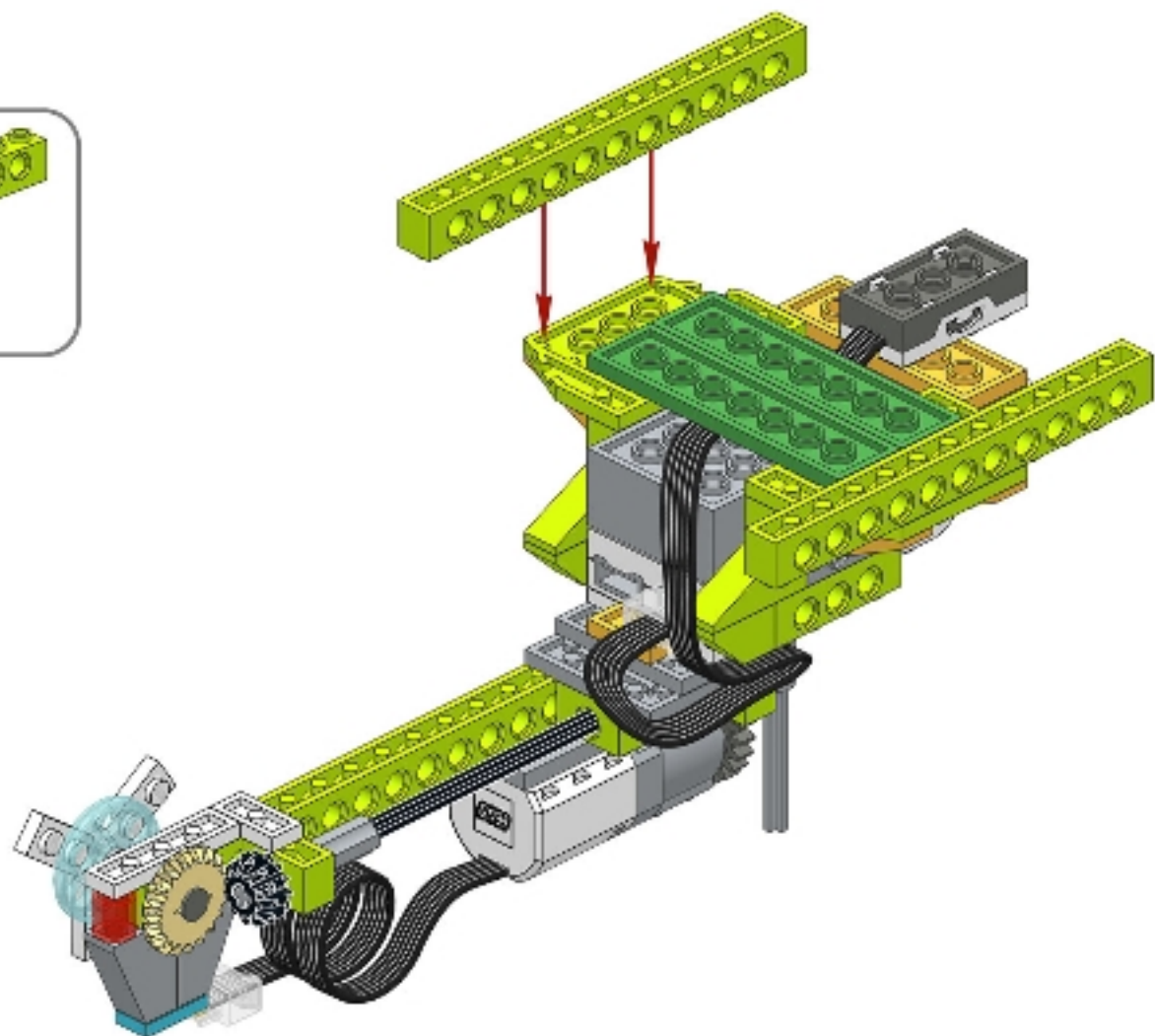

50

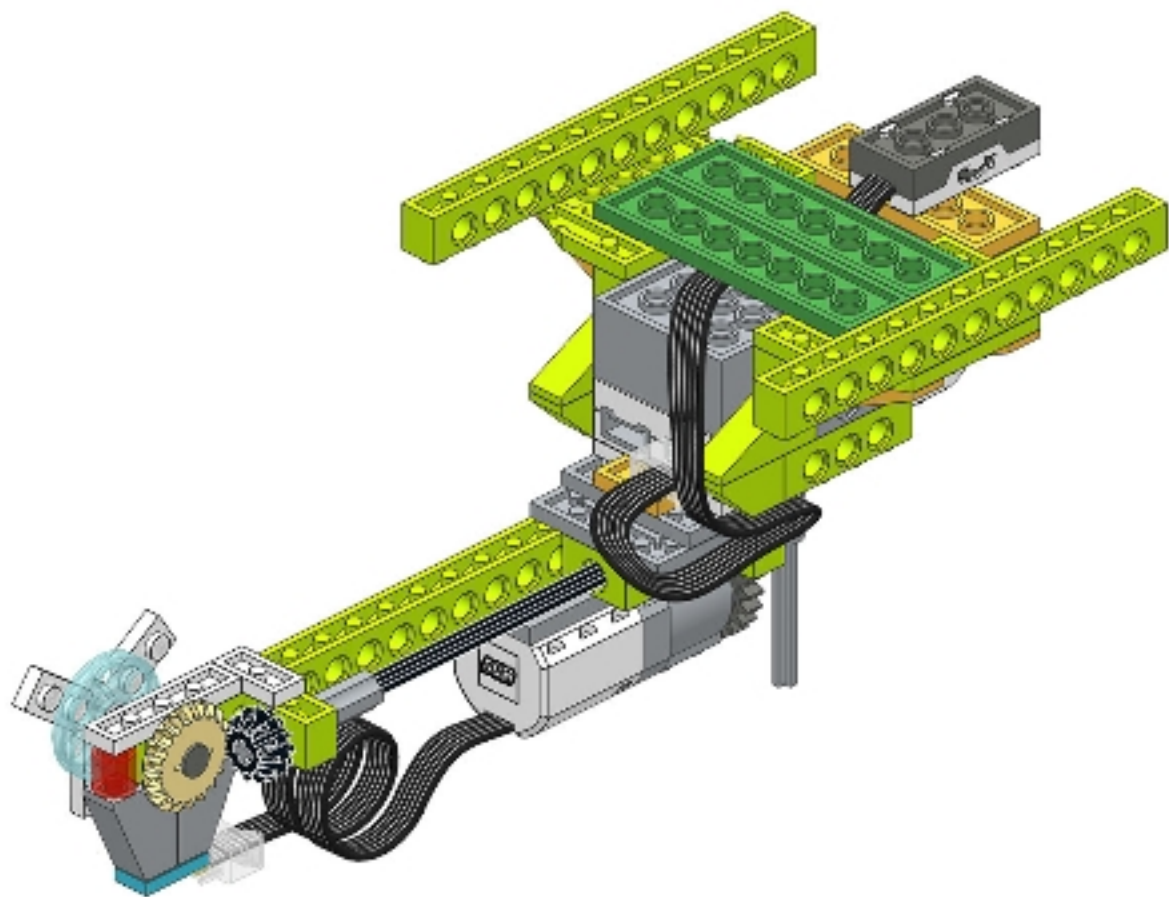

51

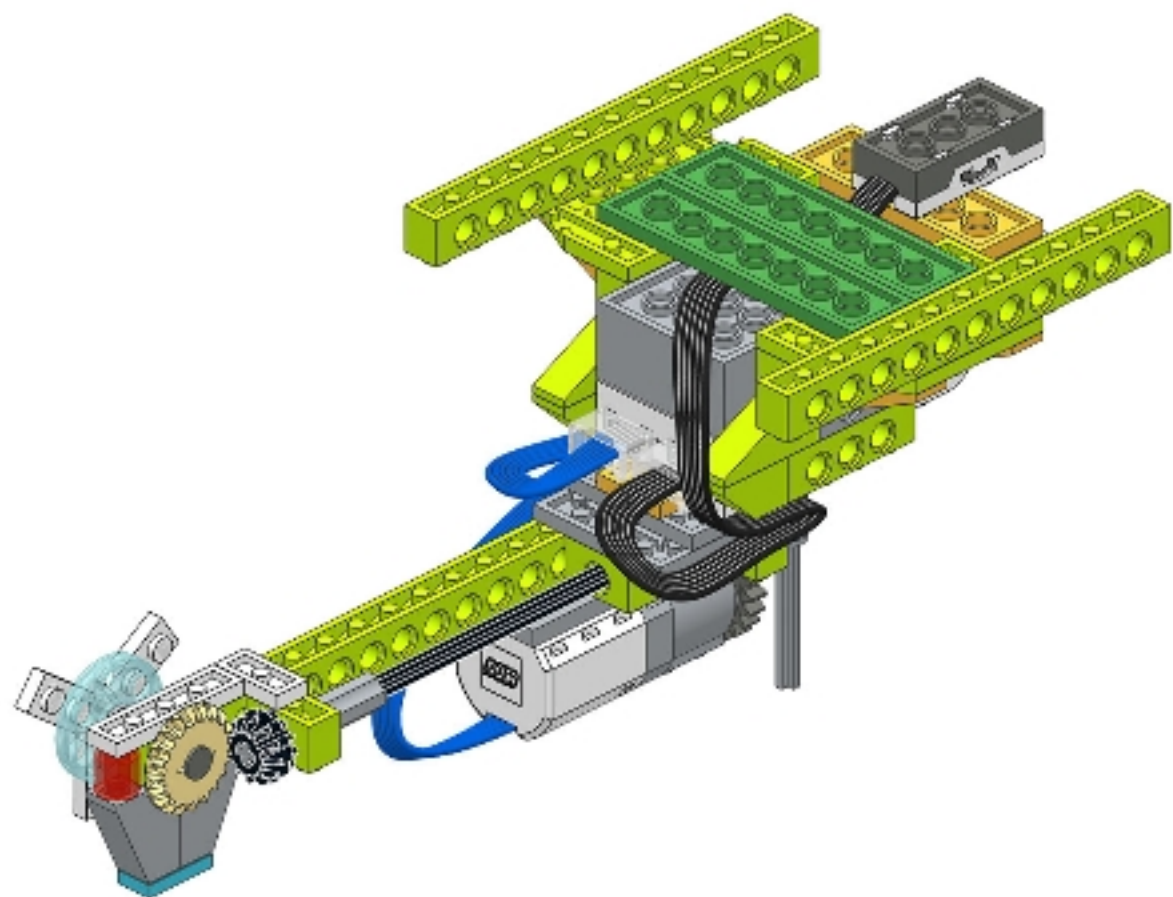

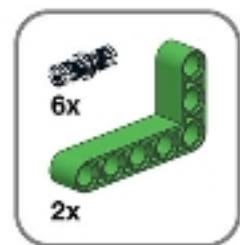

53

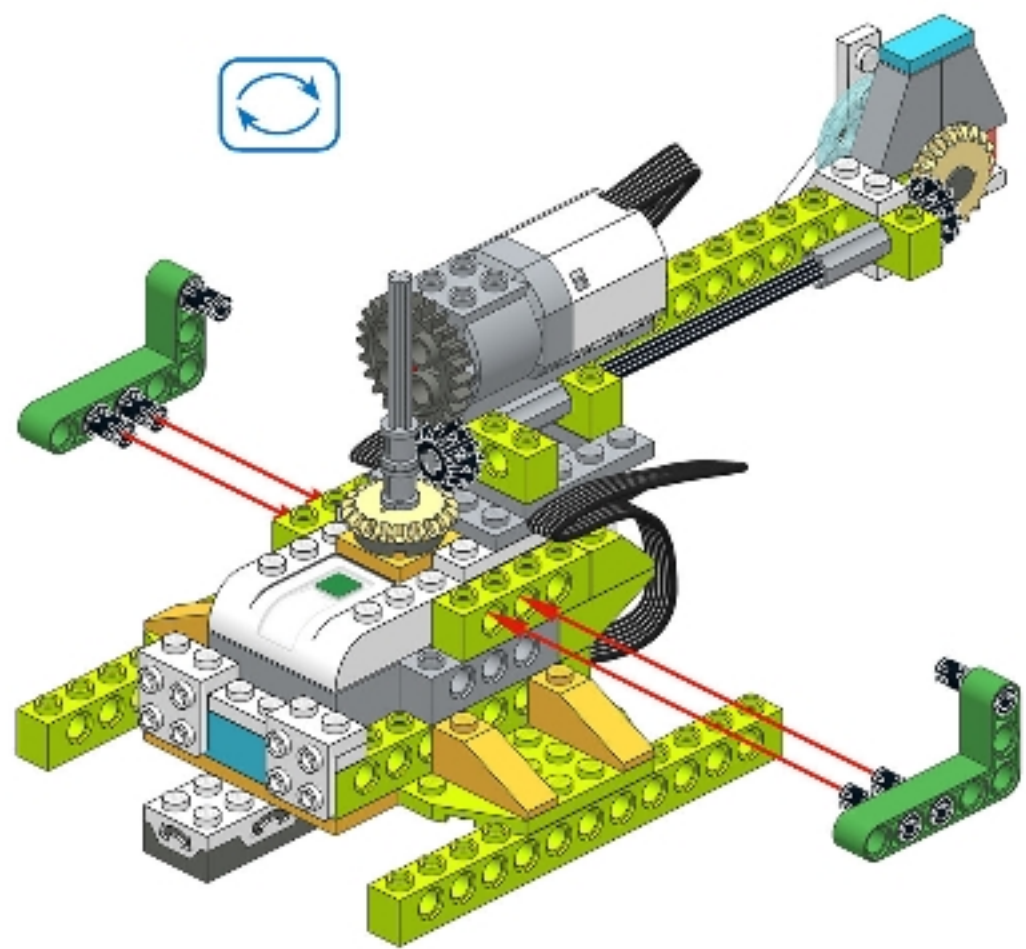

54

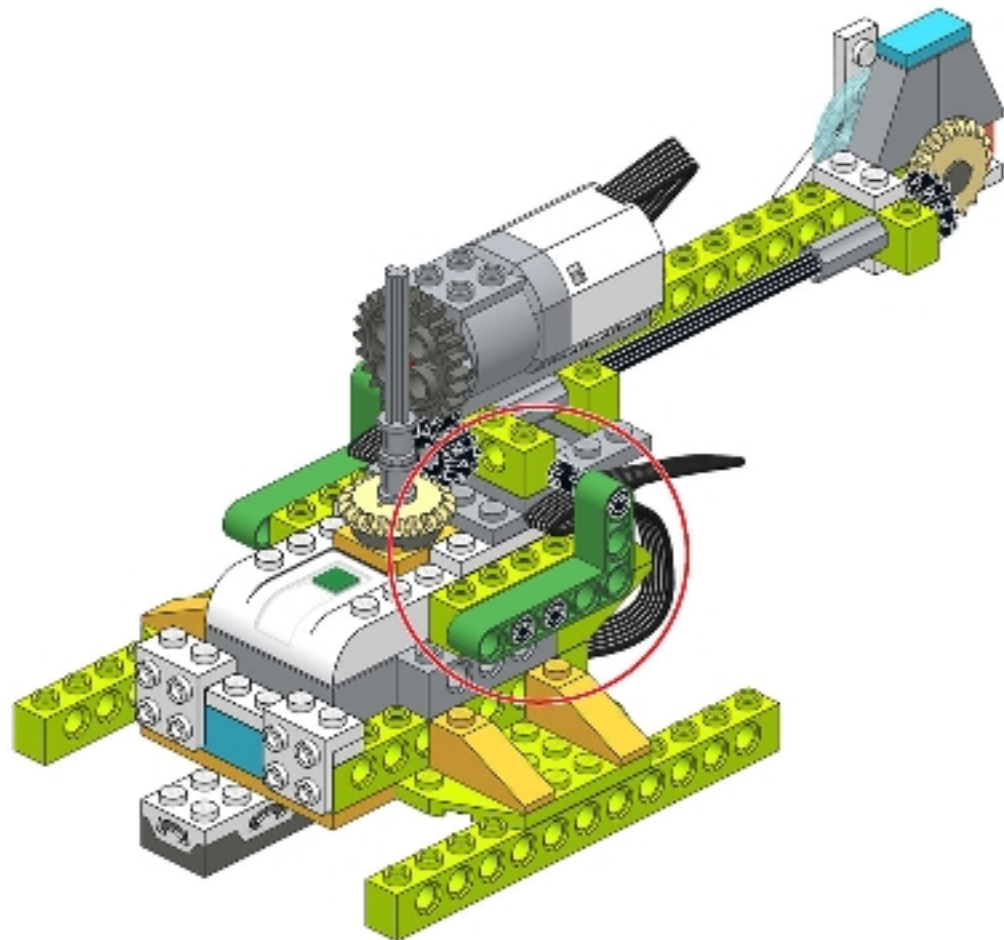

55

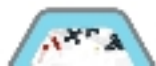
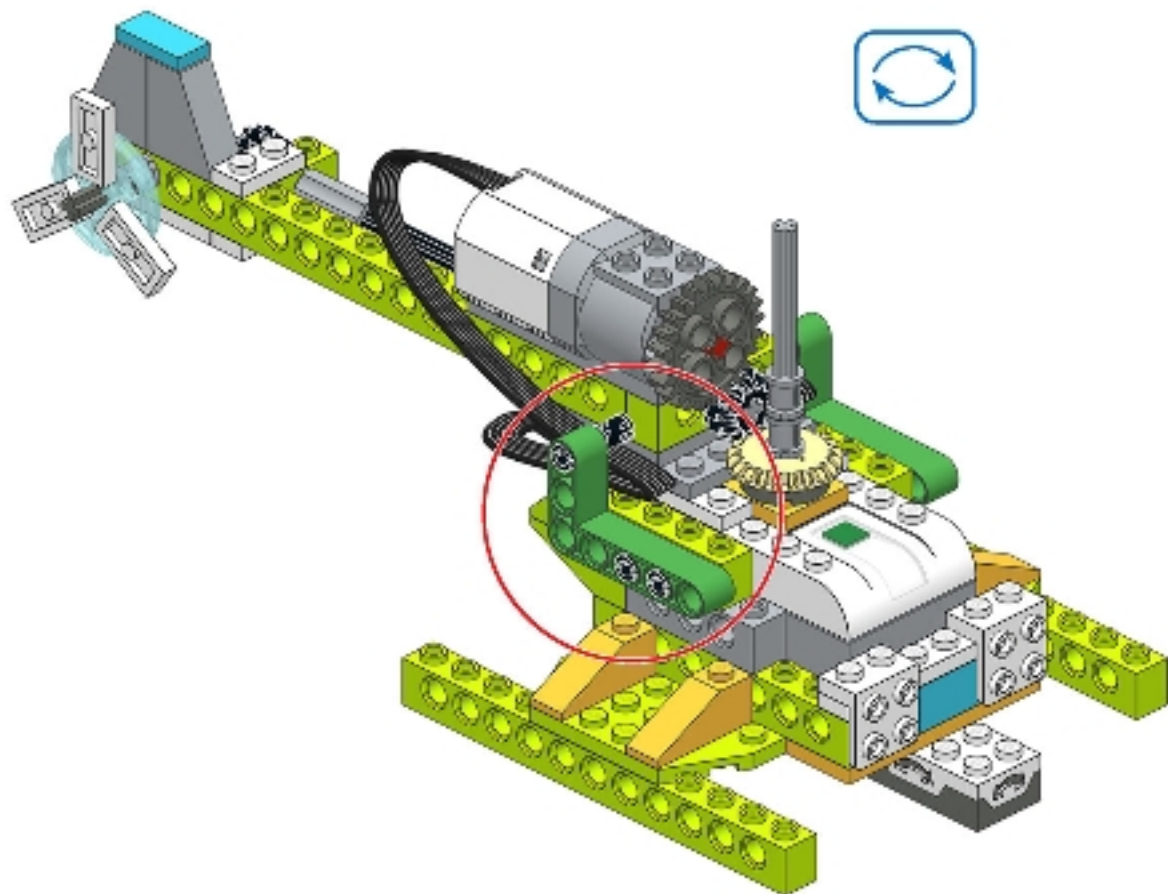

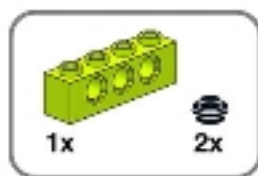
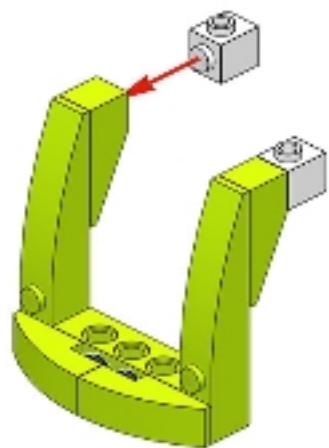

56





2x

57

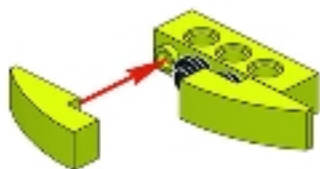

58





2x

59

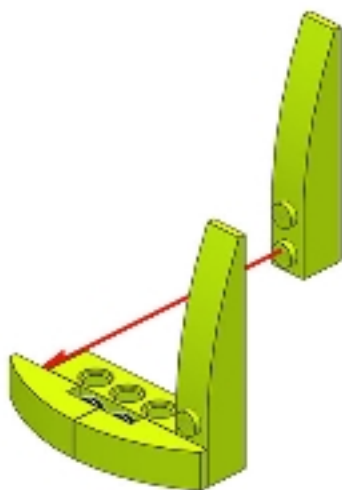

60

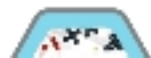
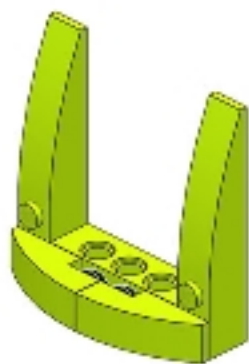



2x

61

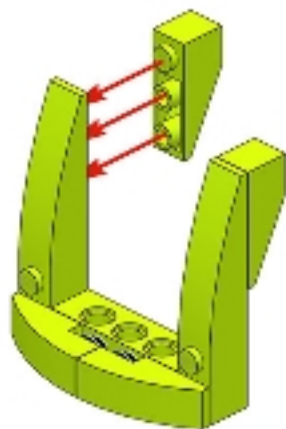



2x

62

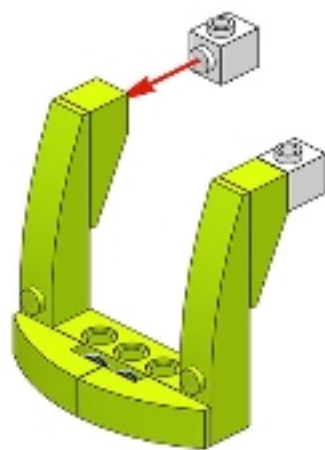

63

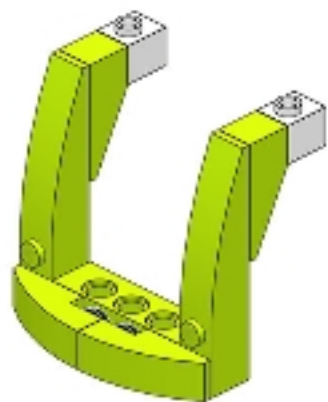

64

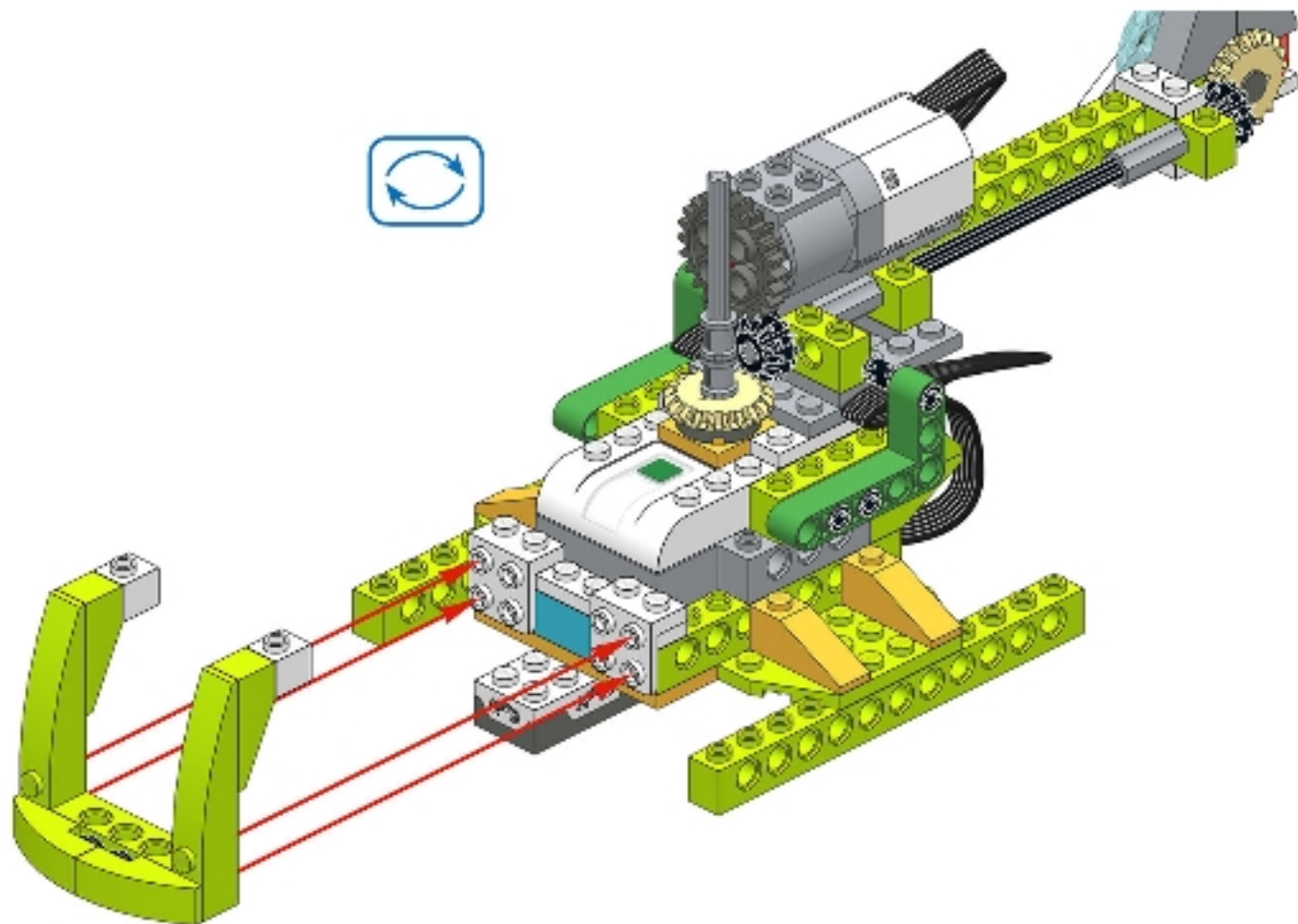

65

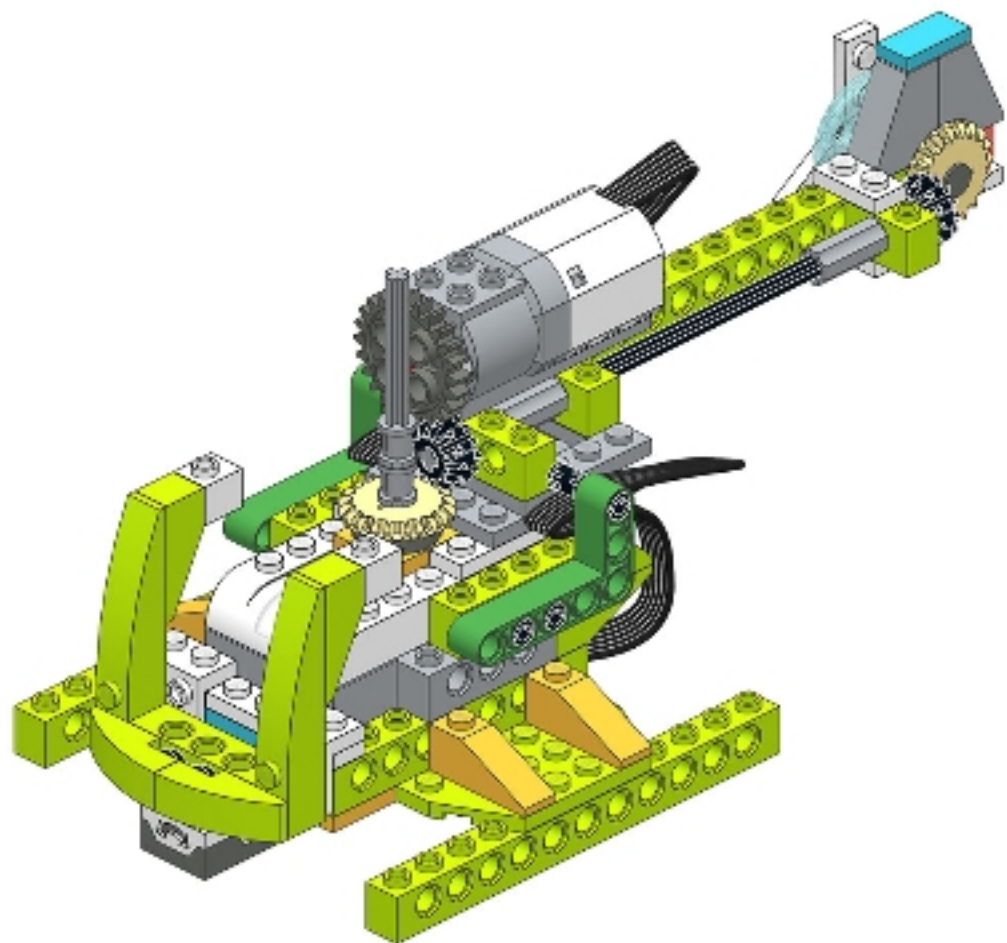



1

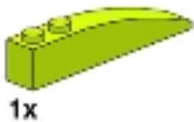
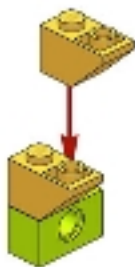

2

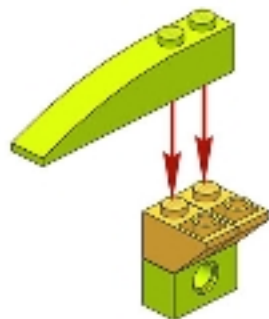

3

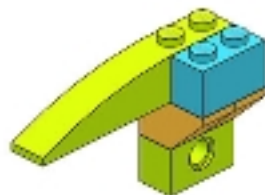

67

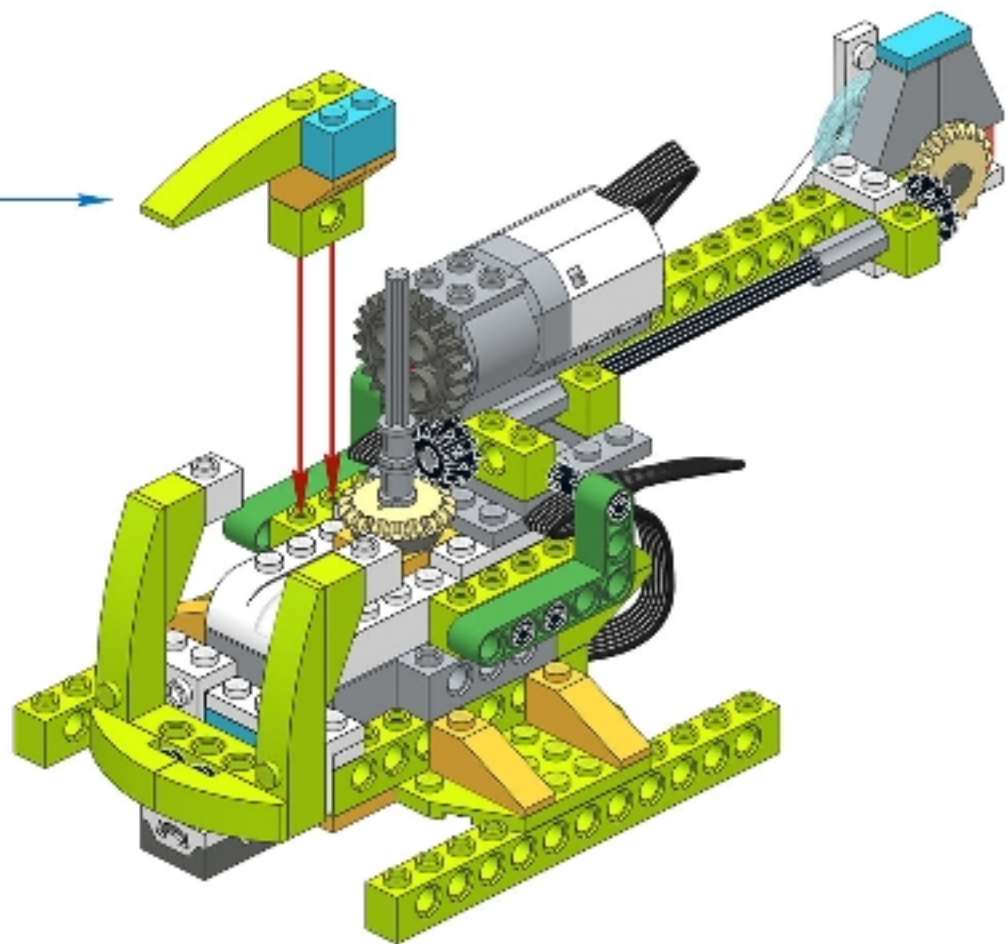

68

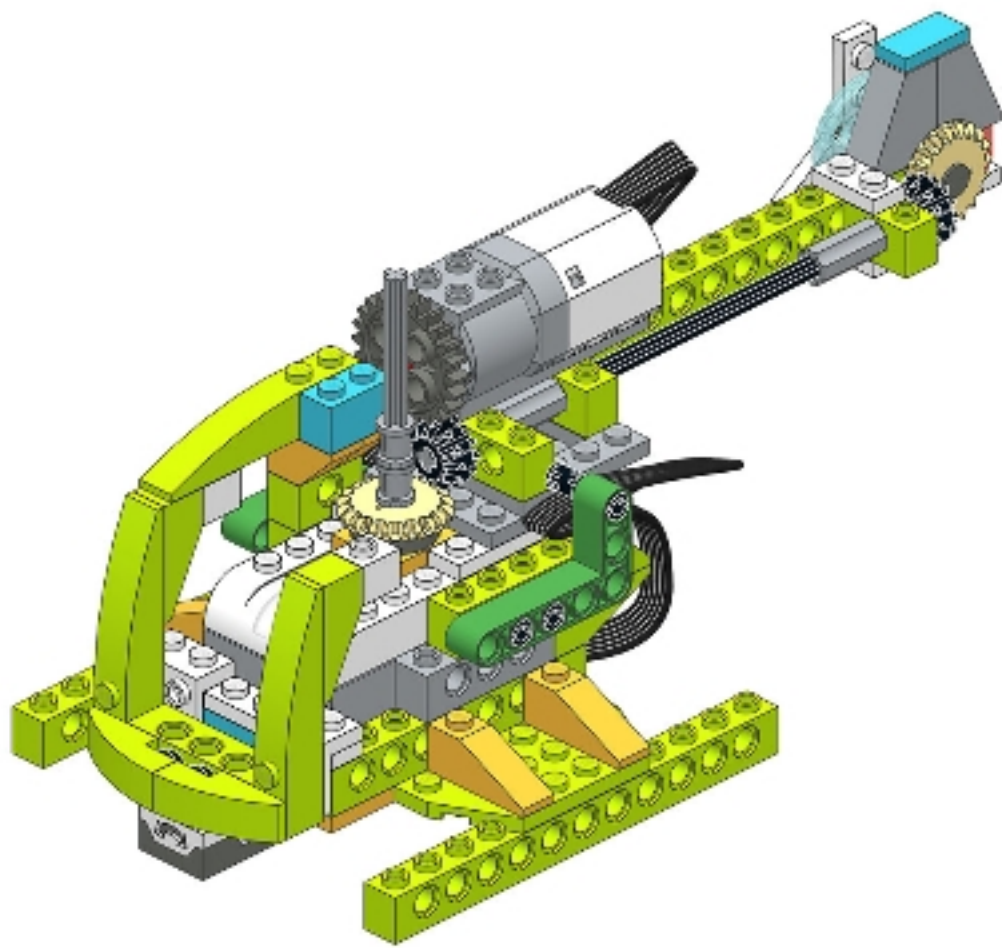

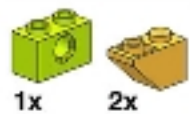

1

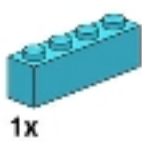
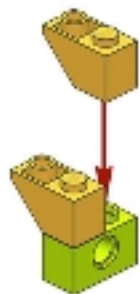

2

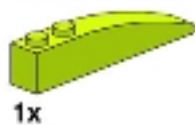
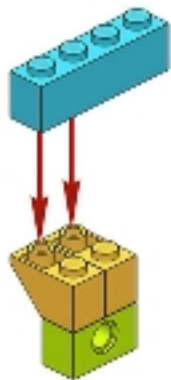

3

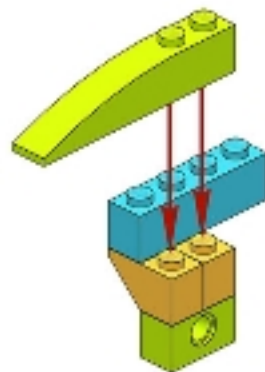

4

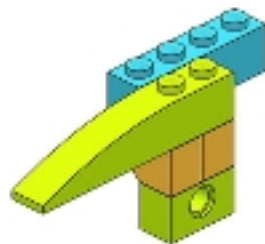

70

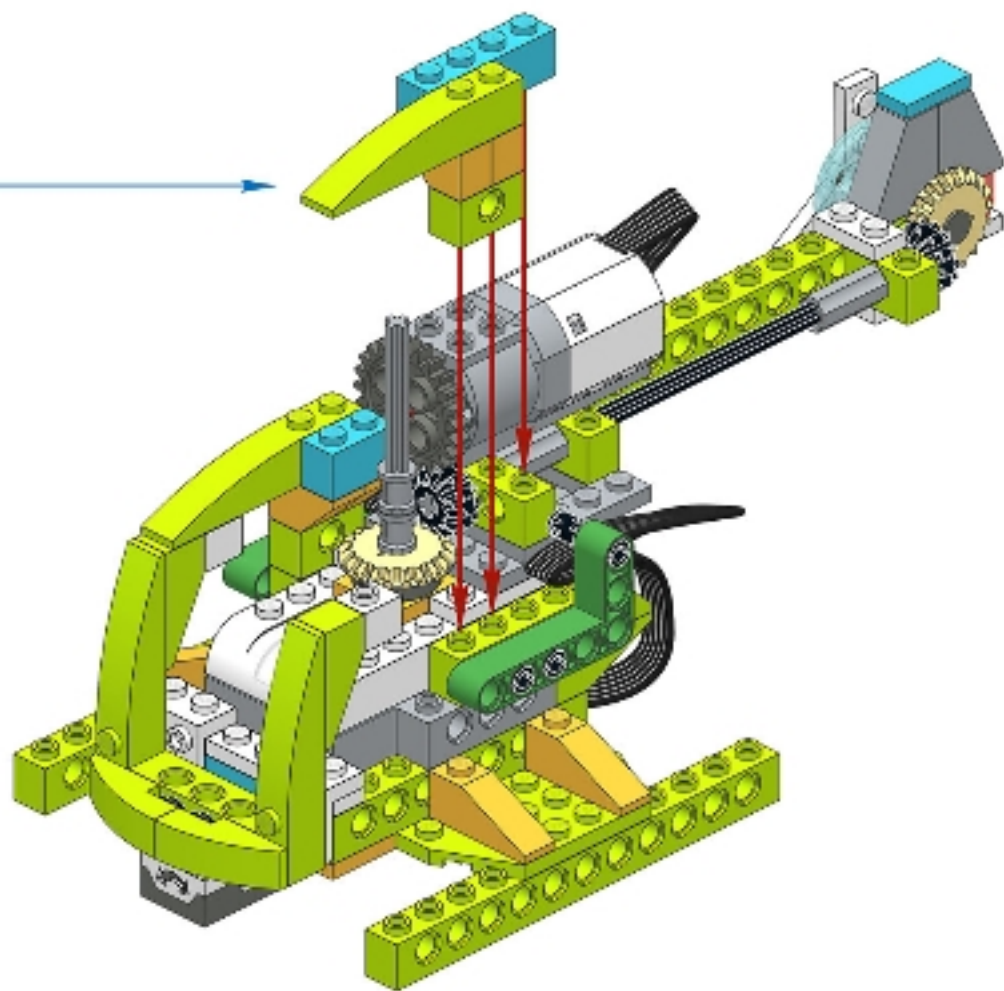

71

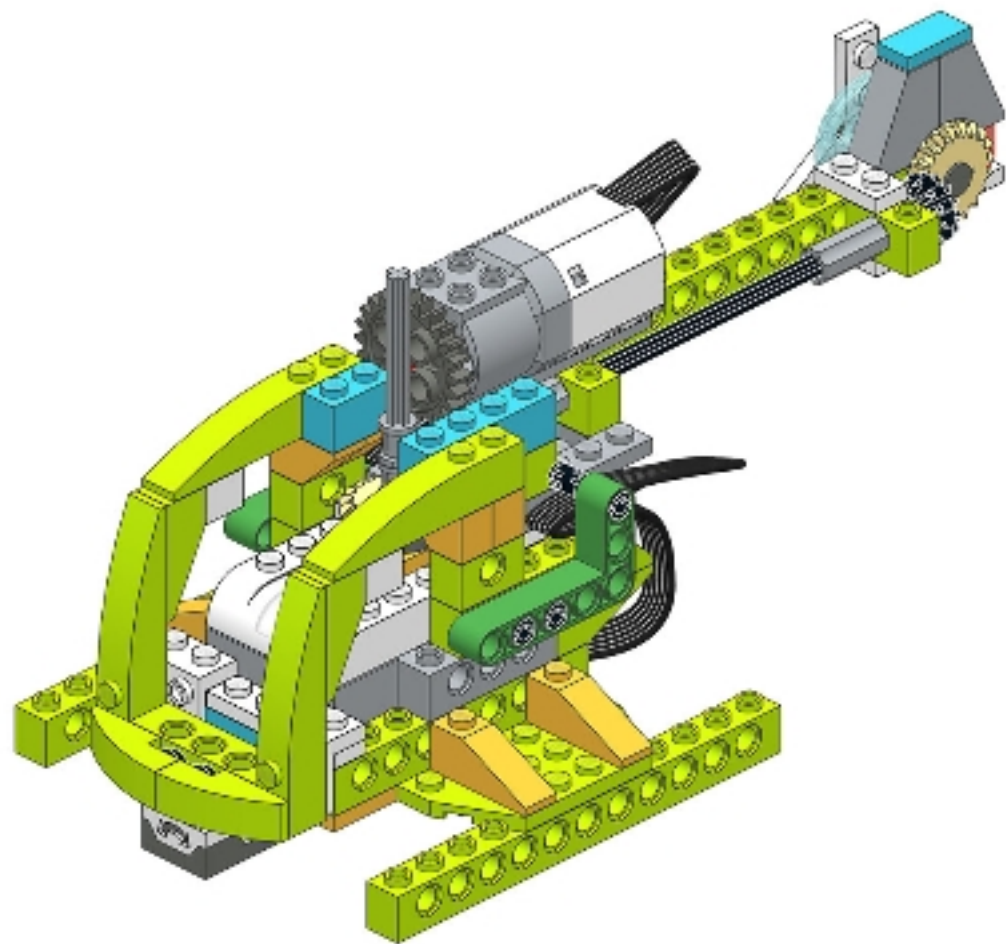

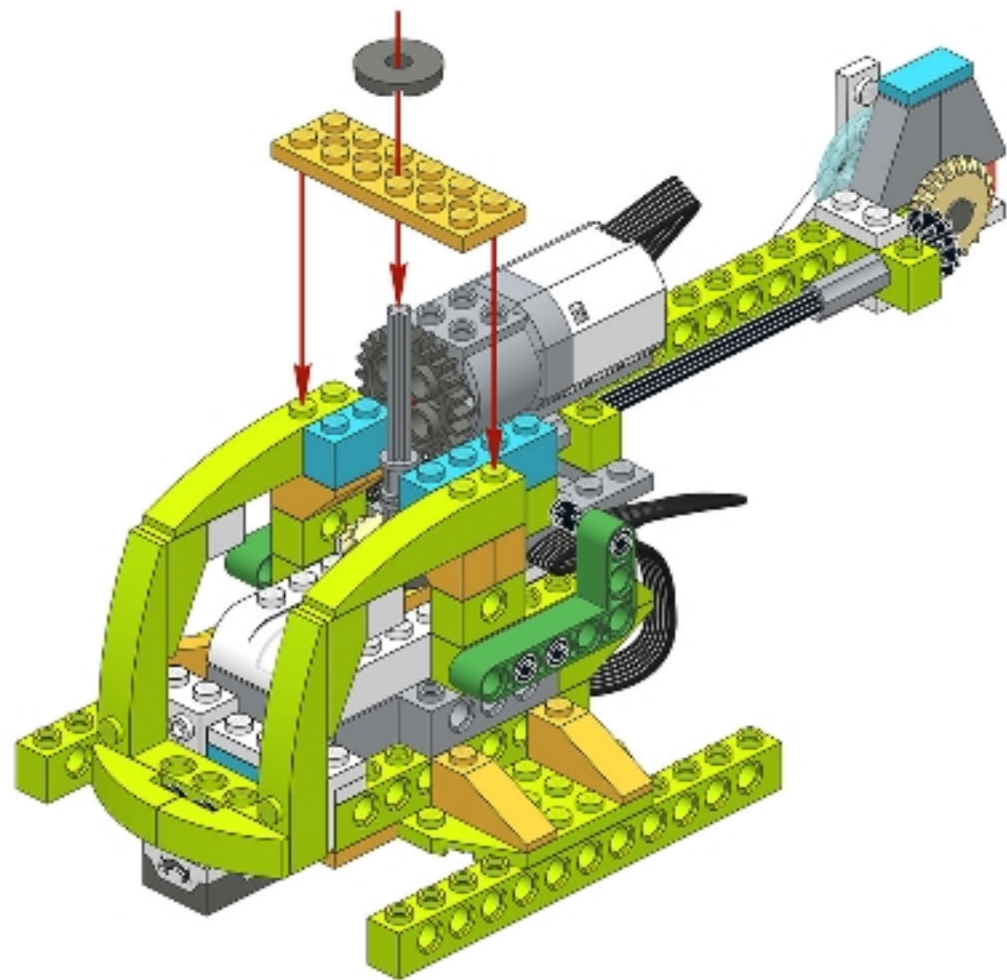

1x



1x

72



73

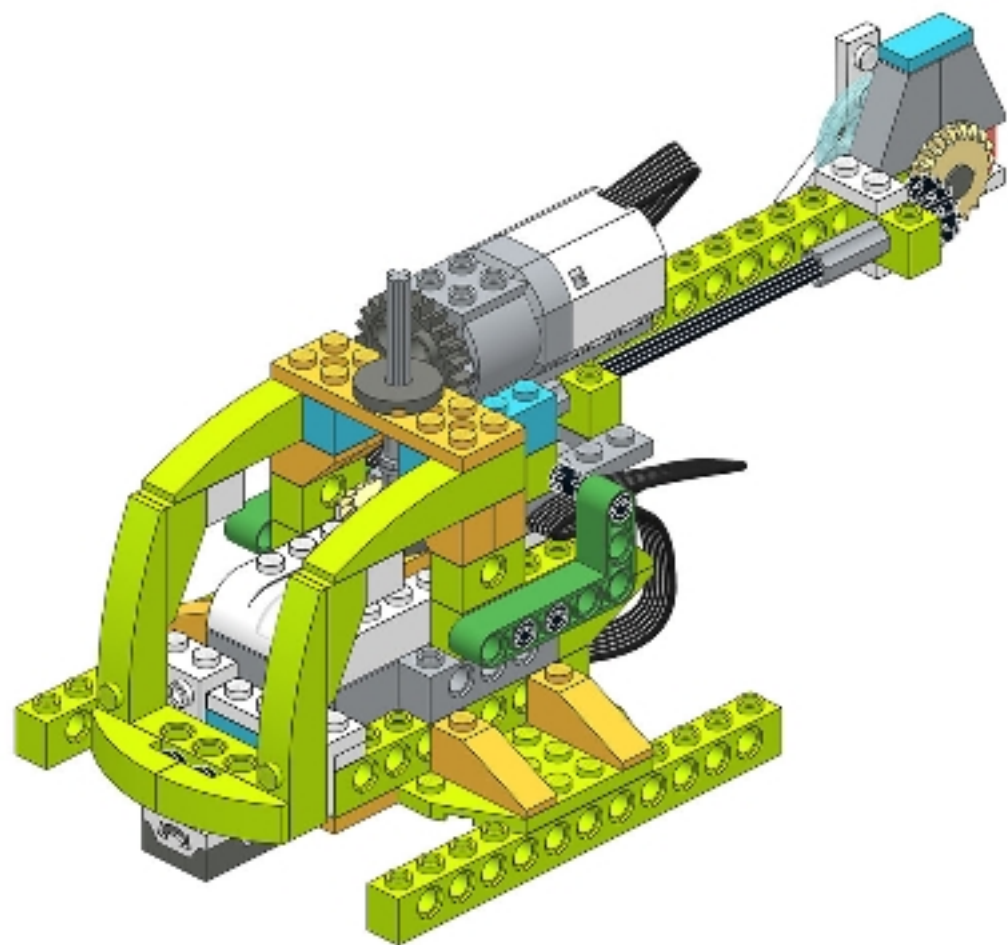

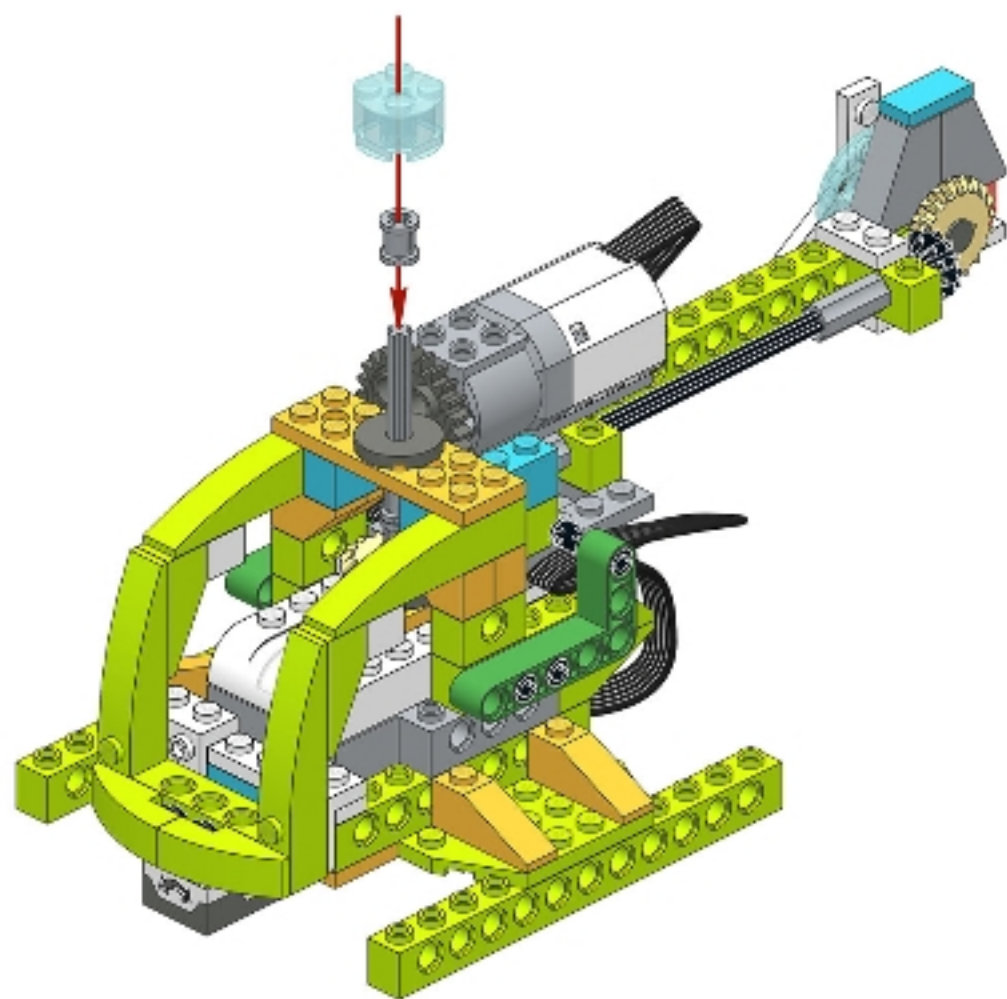

1x



1x

74



75

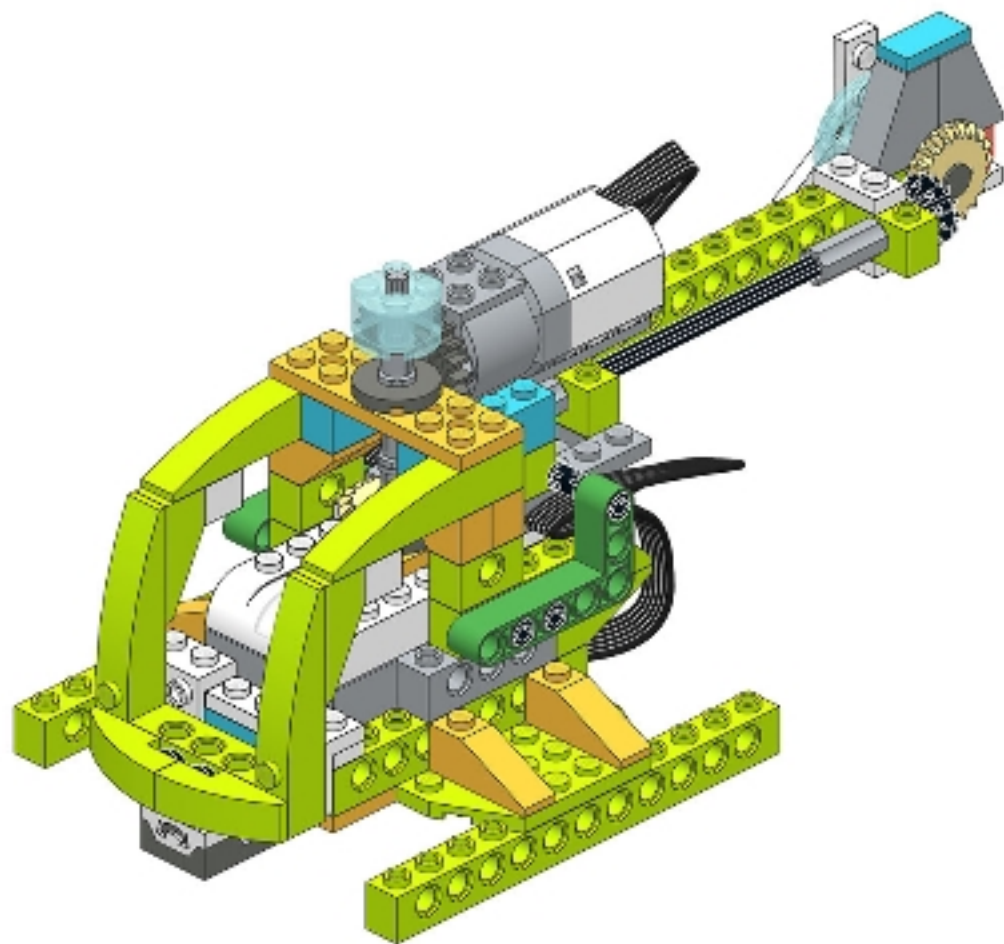

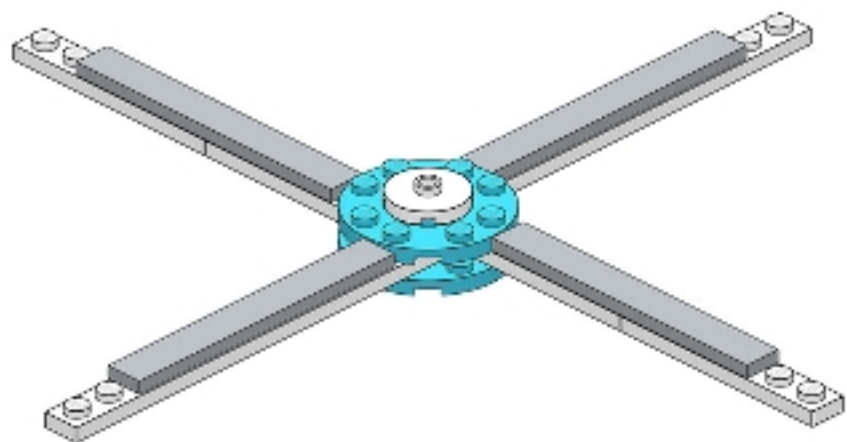

1x

2x

76

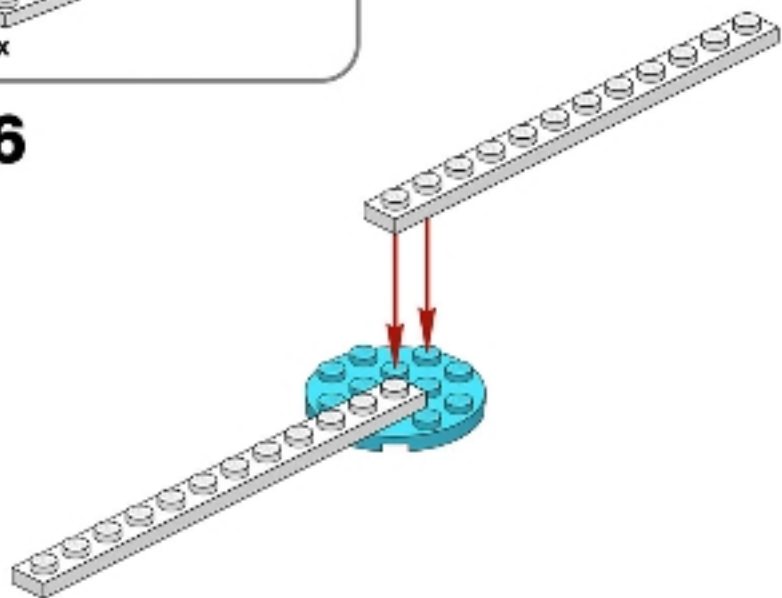



1x

77

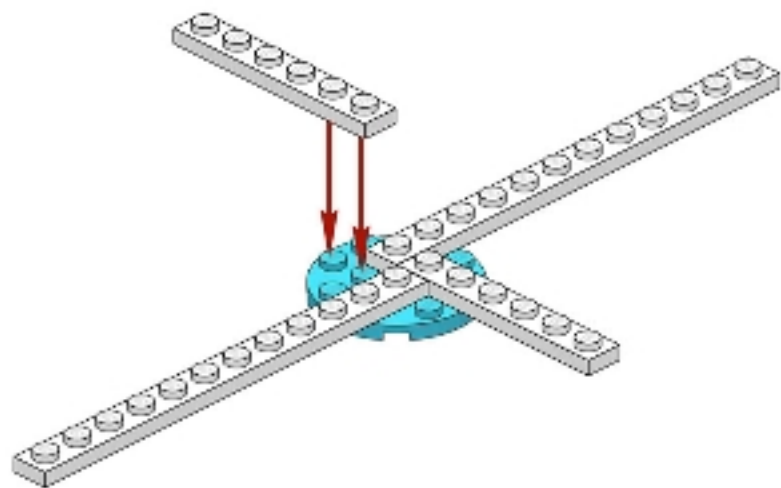



1x

1x

78

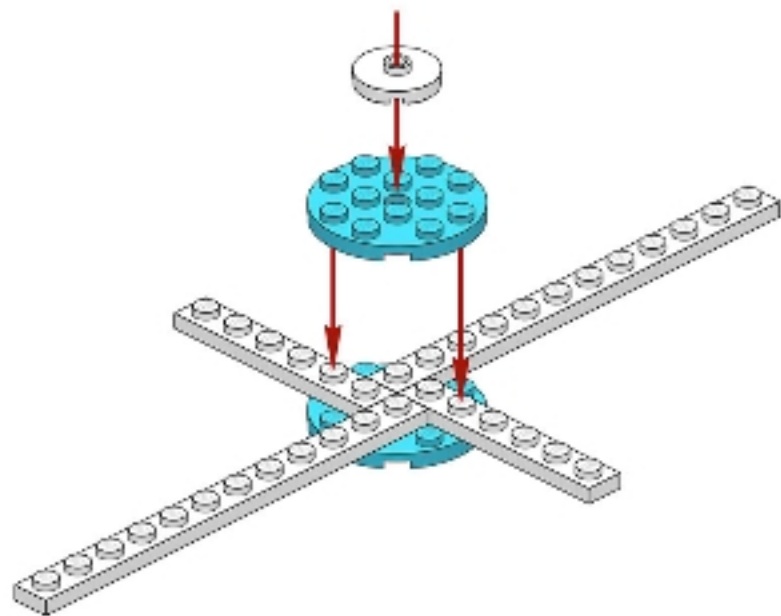

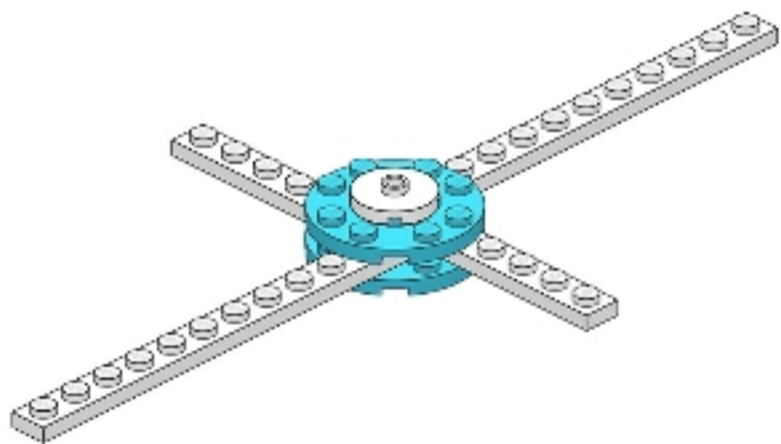

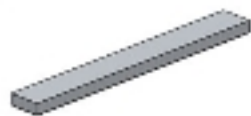

4x

80

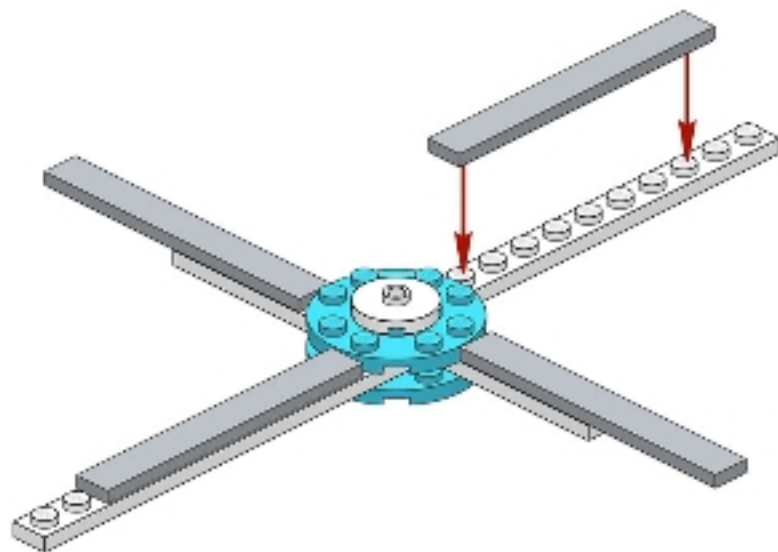

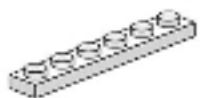

2x

81

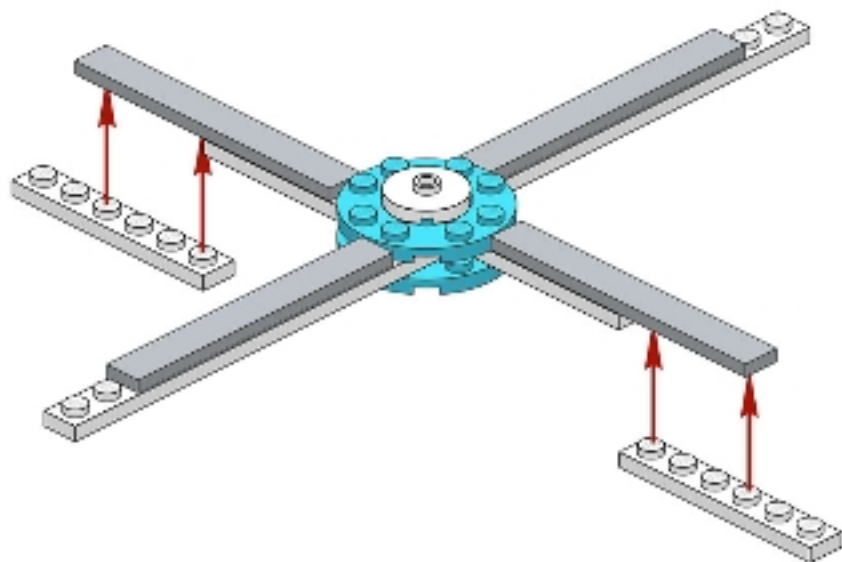

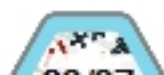
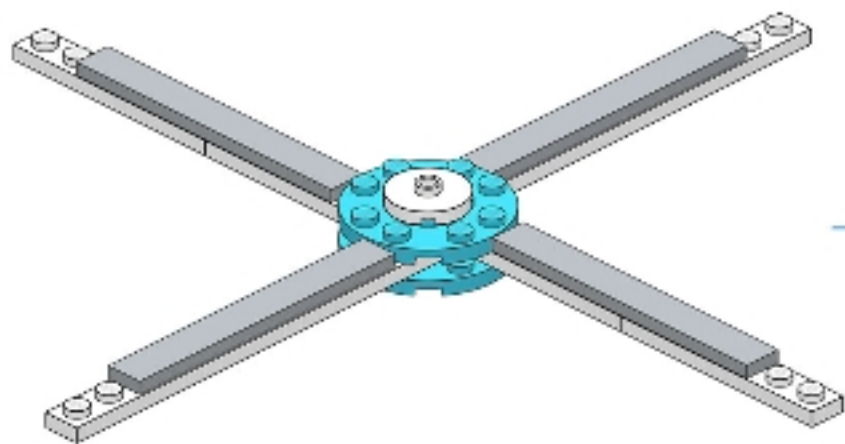

83

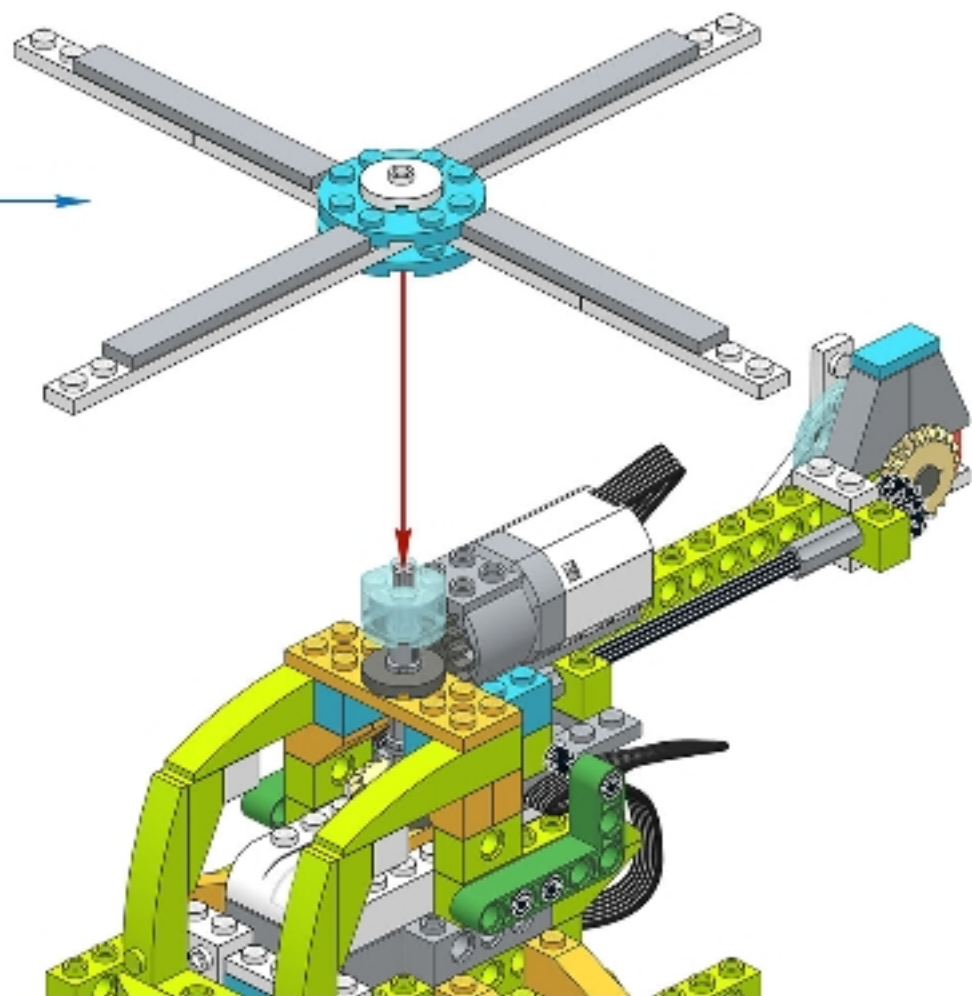

84

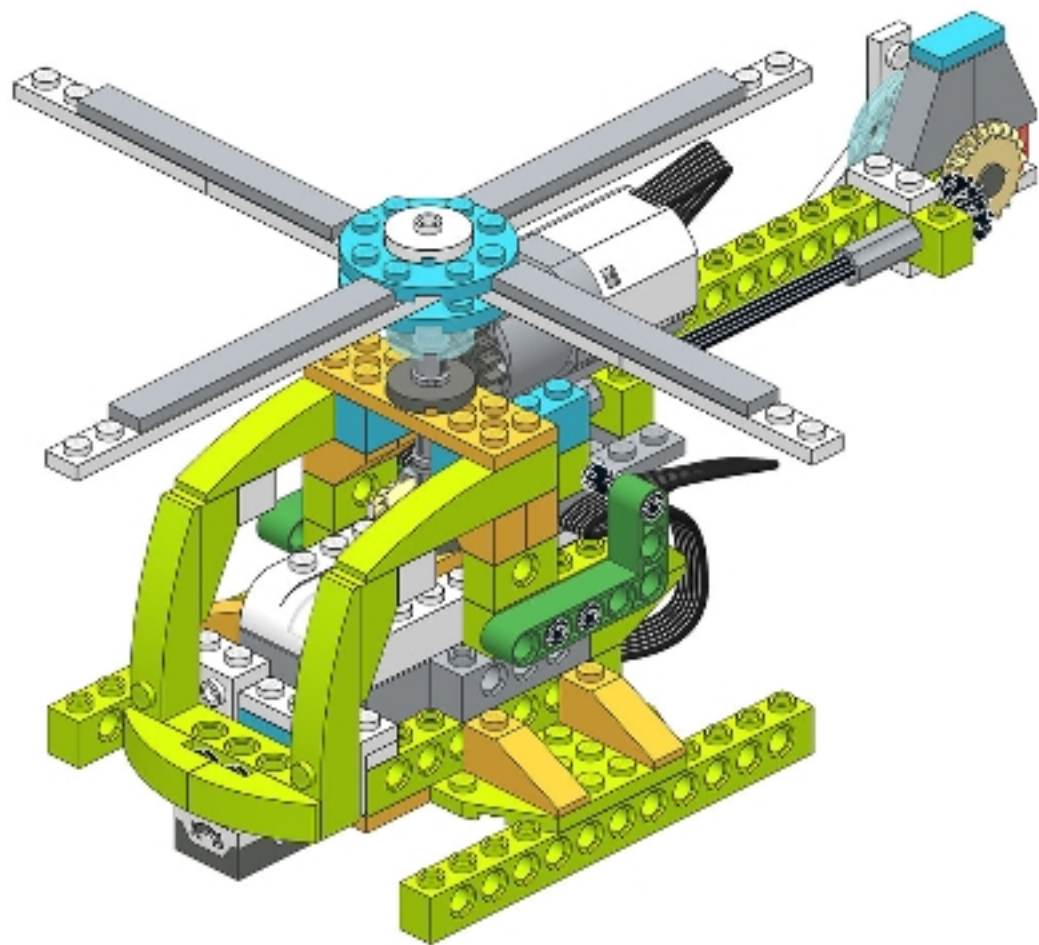



2x

85

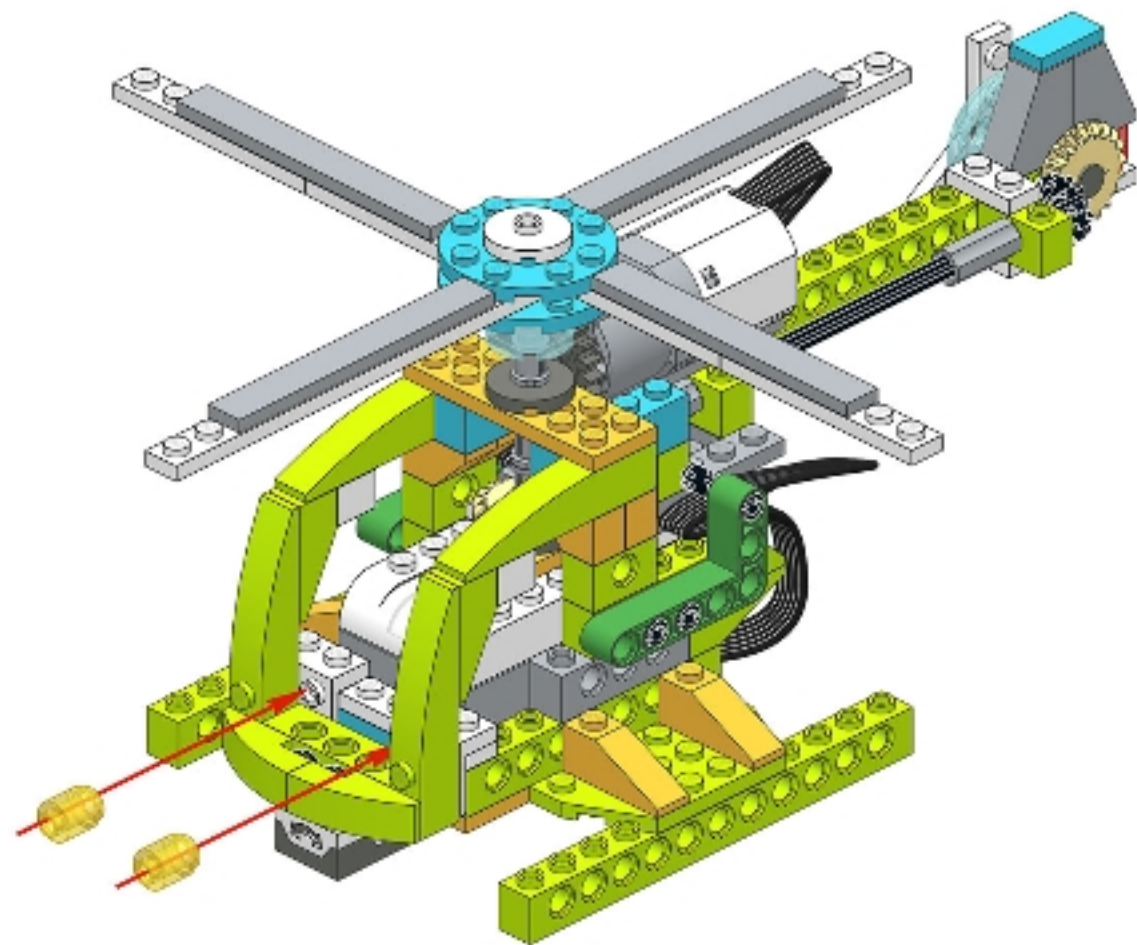

86

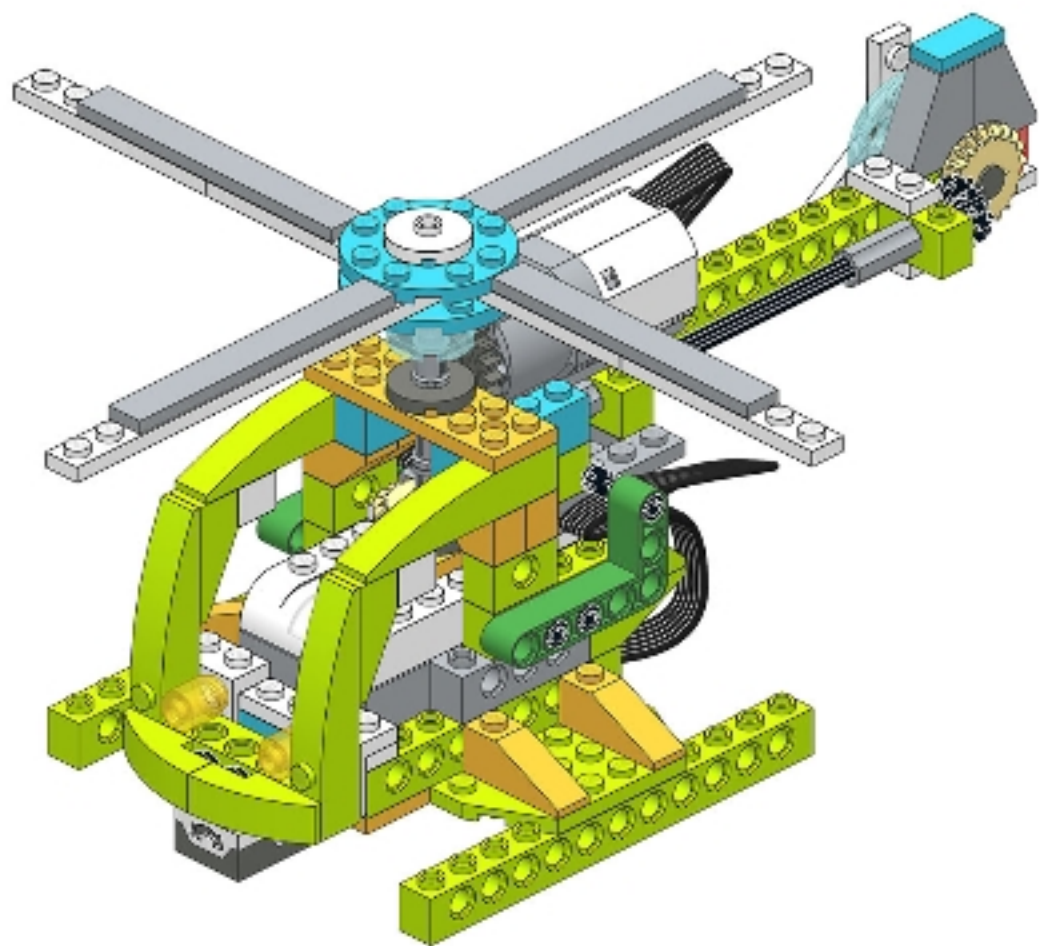



2x

87

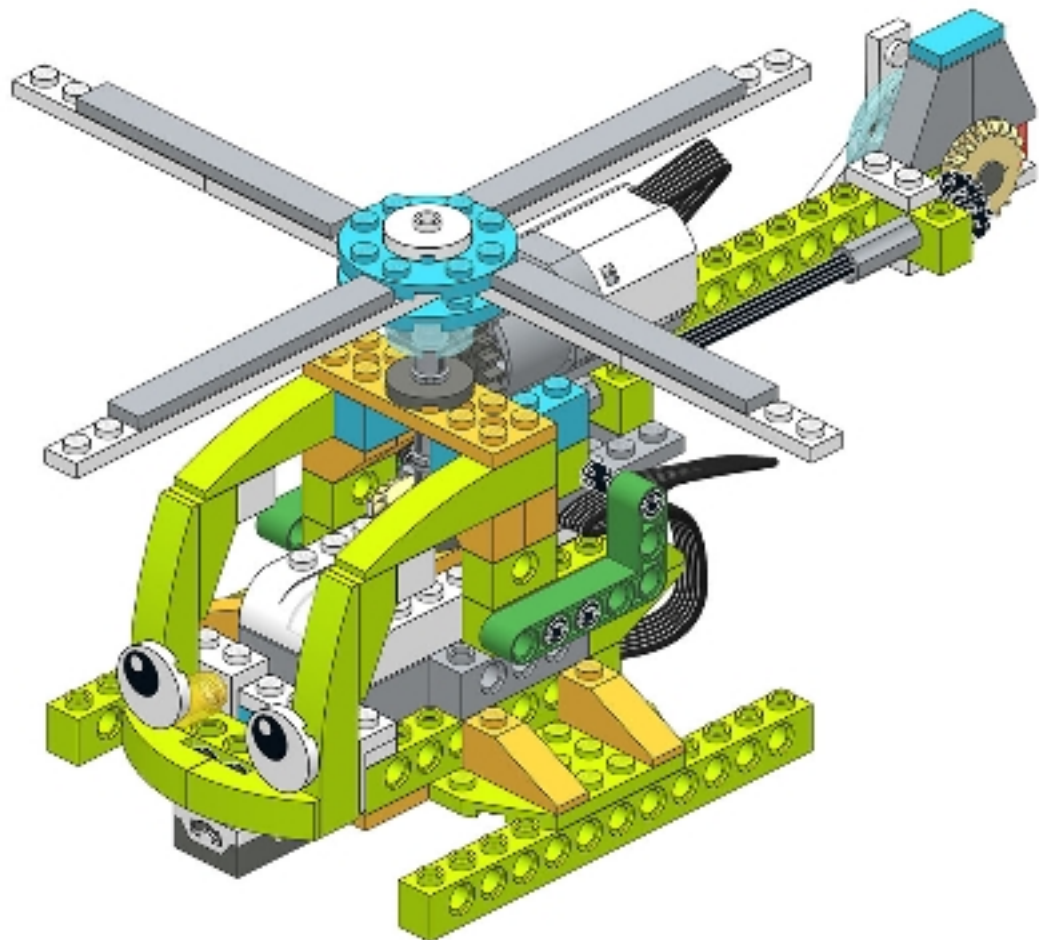

87/87

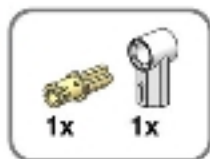

88

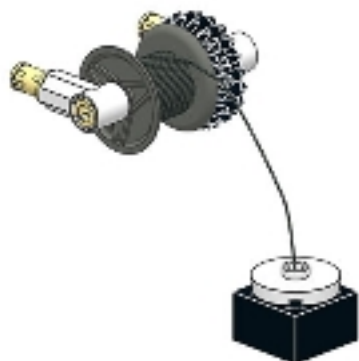



1x



1x

89

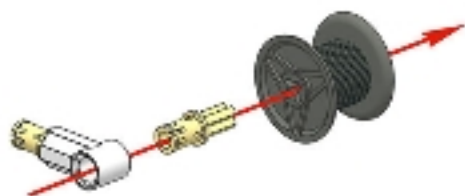



1x



1x

90







92

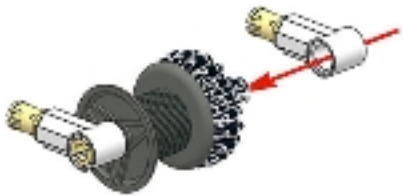





1x



1x

94



95

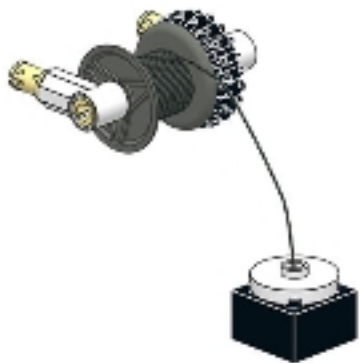

96

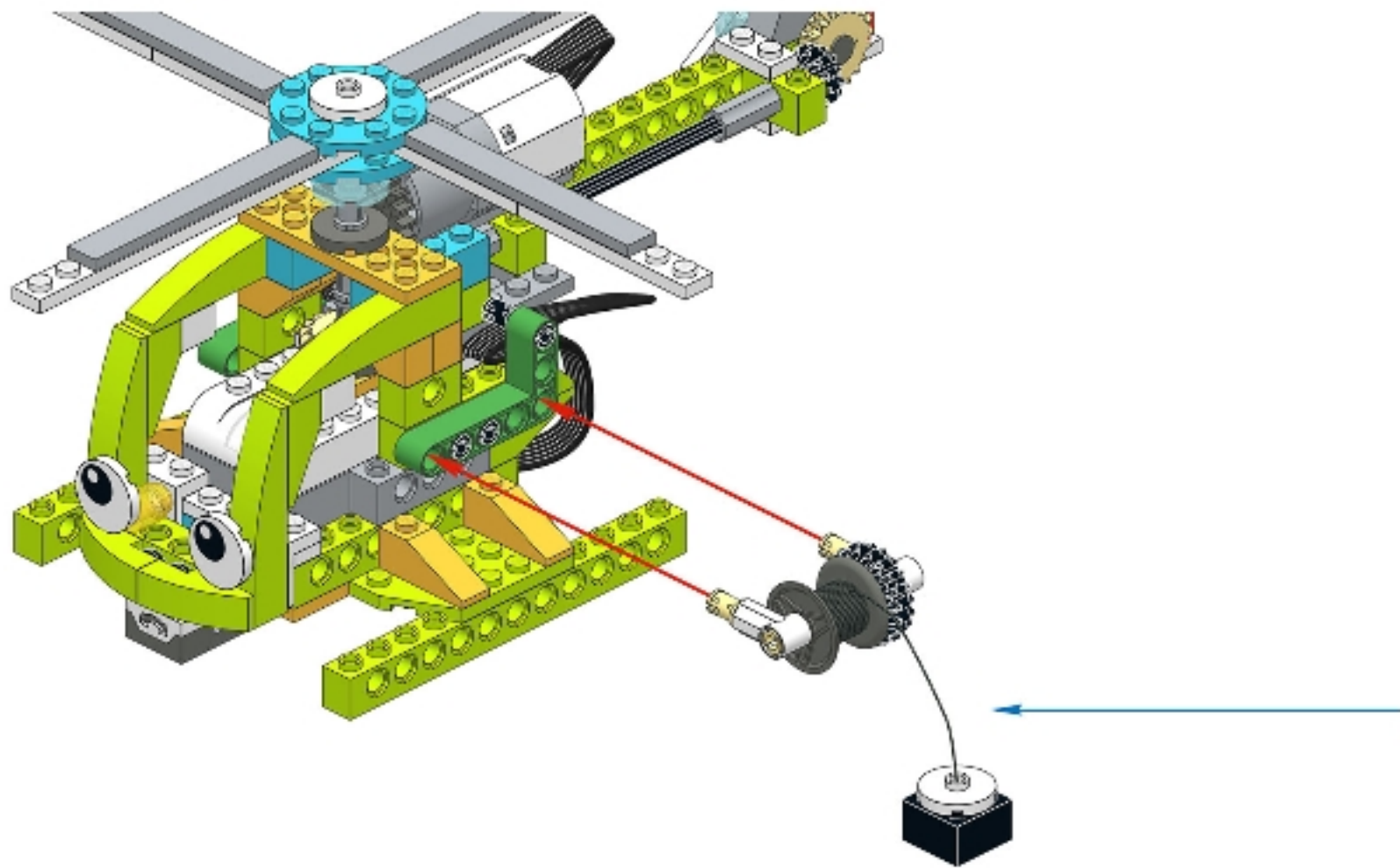

97

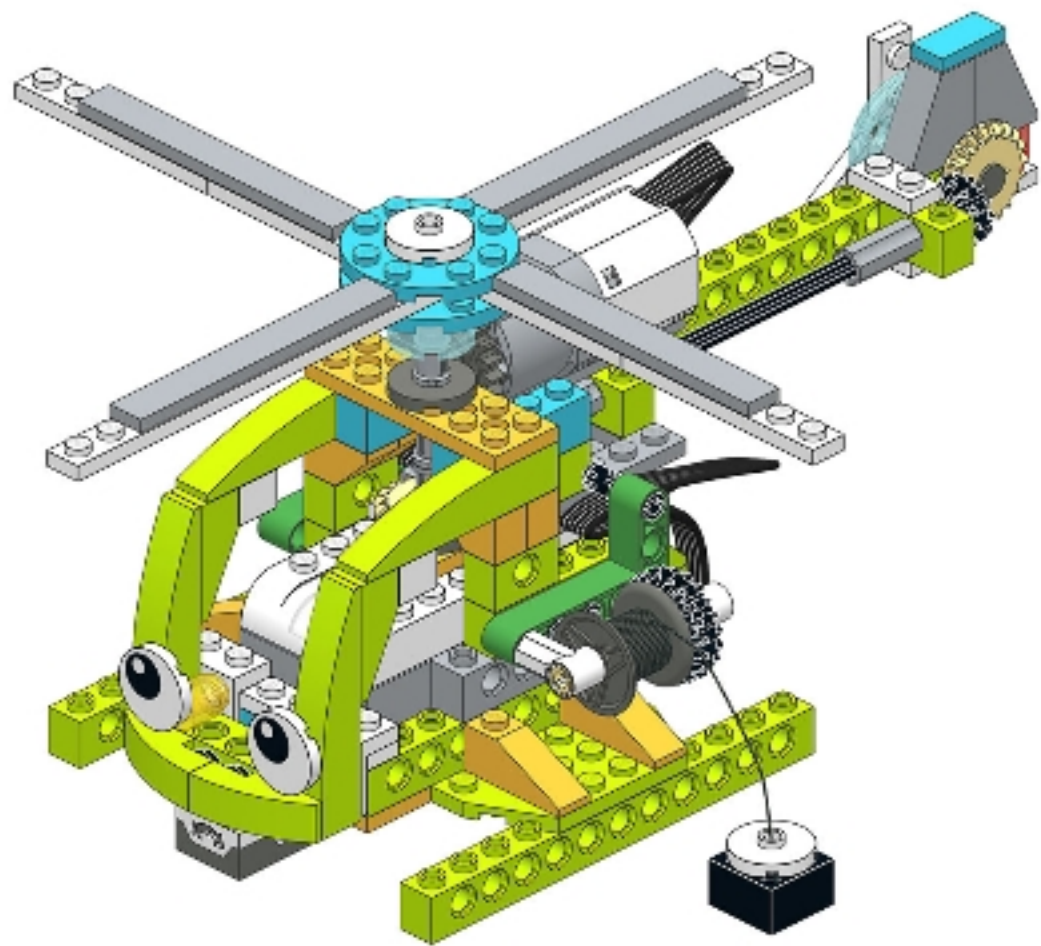

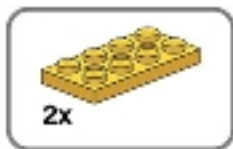

2x

98

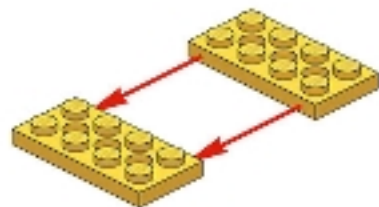



3x

99



12/24



1x

100

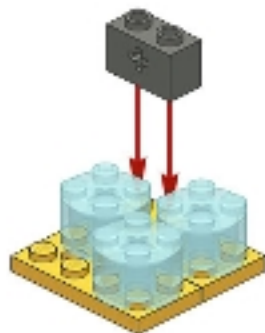

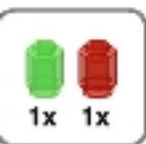

101



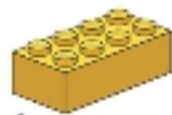

2x

102

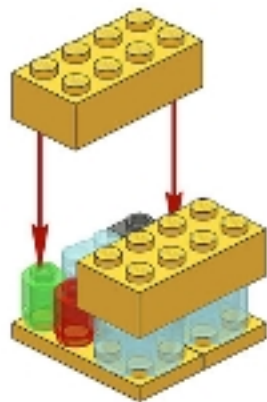



1x

103

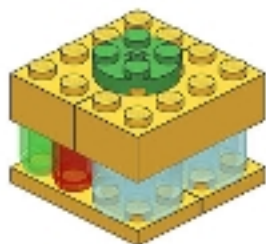



104



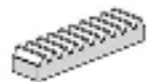

2x

105



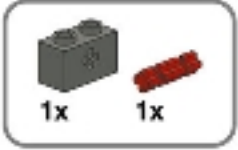

106

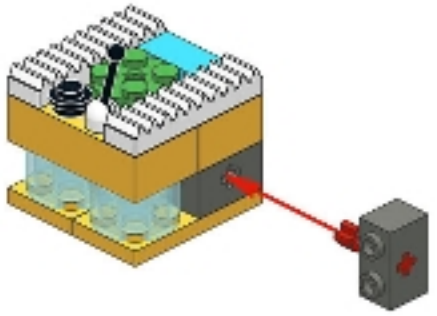



2x

107





1x

1x

108

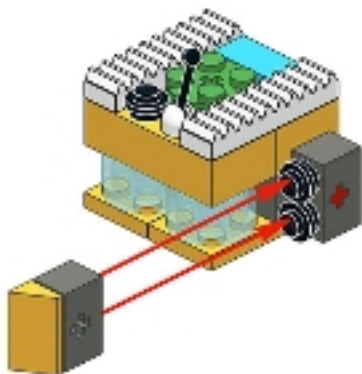

109



111

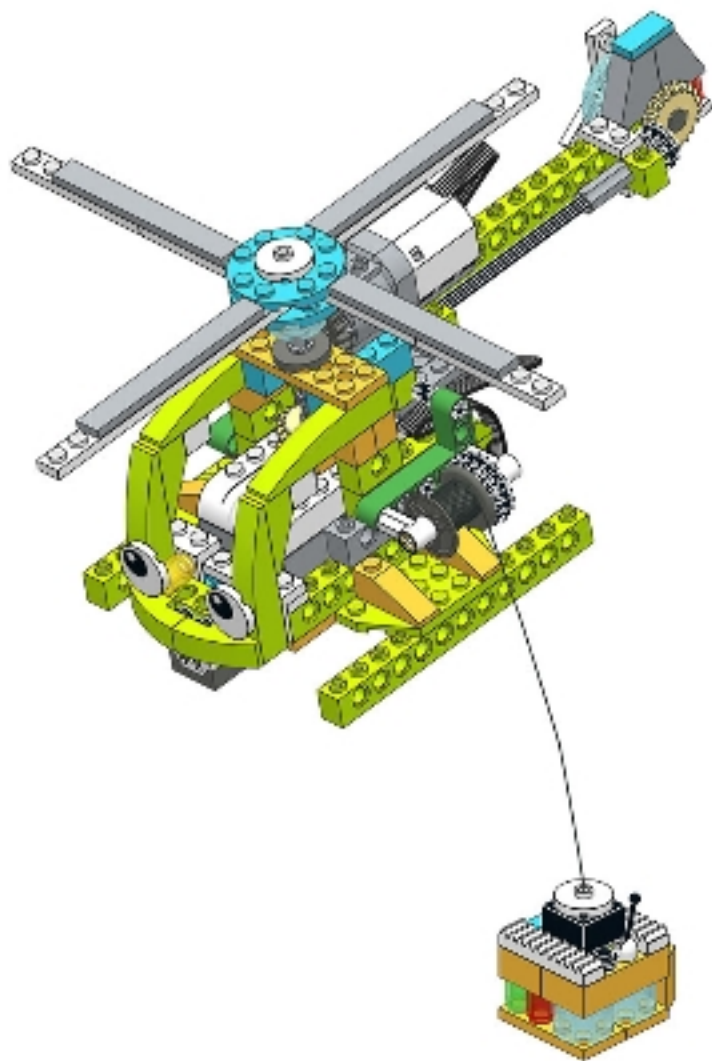



Task 2. Program

Modify the program with the following example:





Task 4. Program

Modify the program you wrote as follows:



In the horizontal position sensor displays a "0". Therefore, the rotors did not turn. If you add a small number to the sensor, for example, 2, the rotors will not stop, and at different positions of the robot, the rotors will have different speeds.