

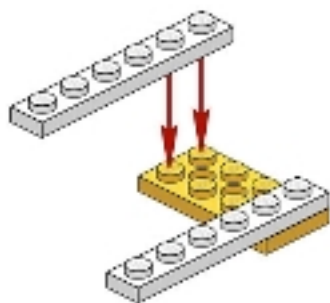

1x



2x



1



1x



1x

2

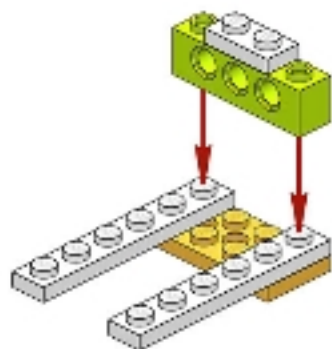



2x

3

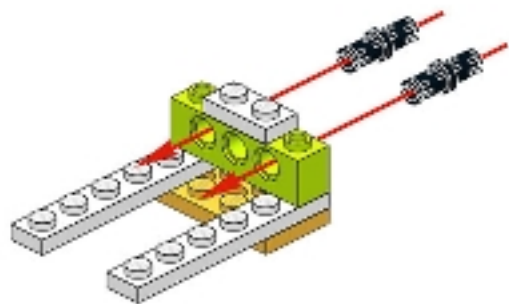

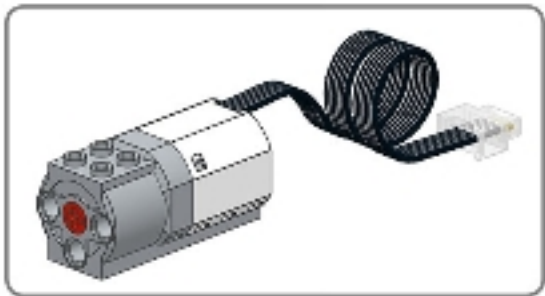

4

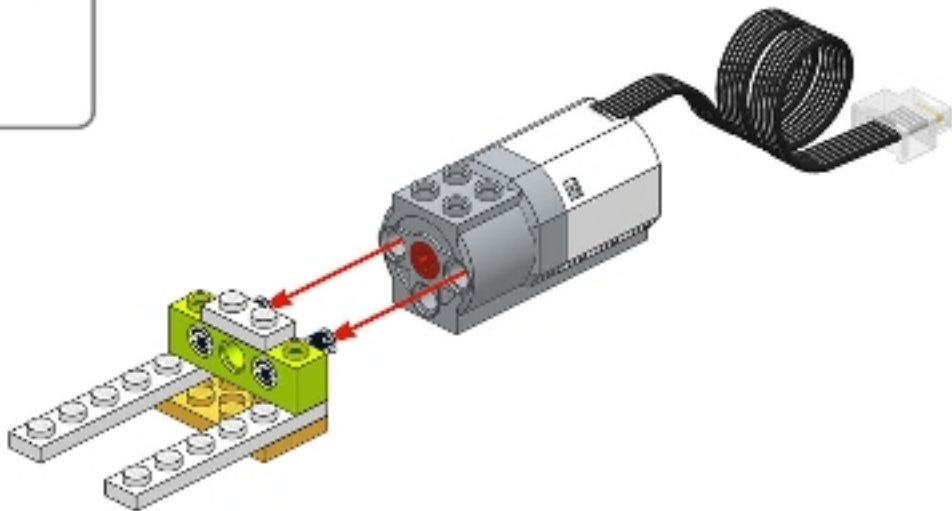

5

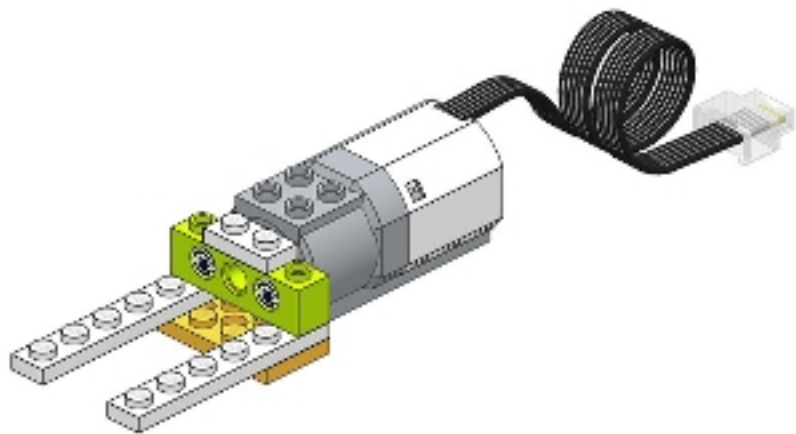



1x



6

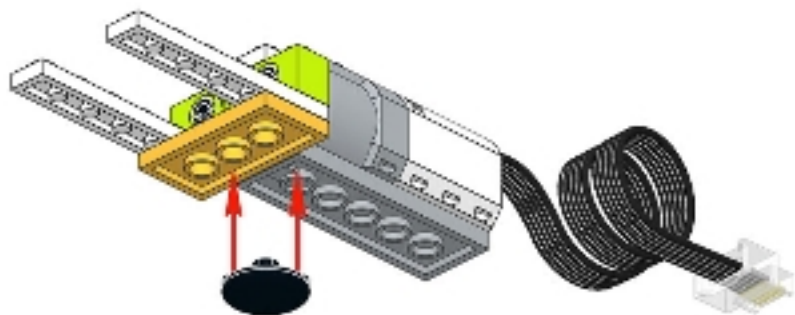

7

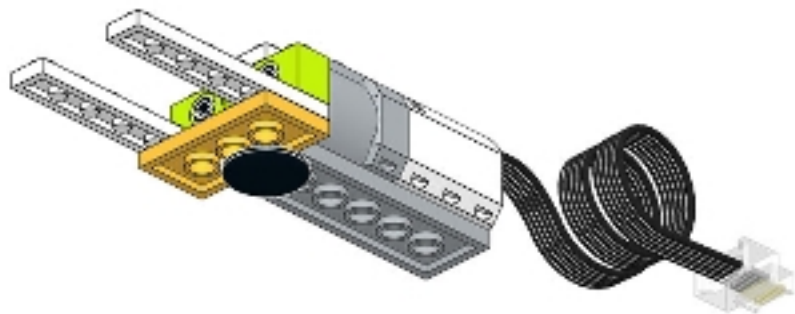

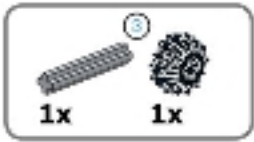

8

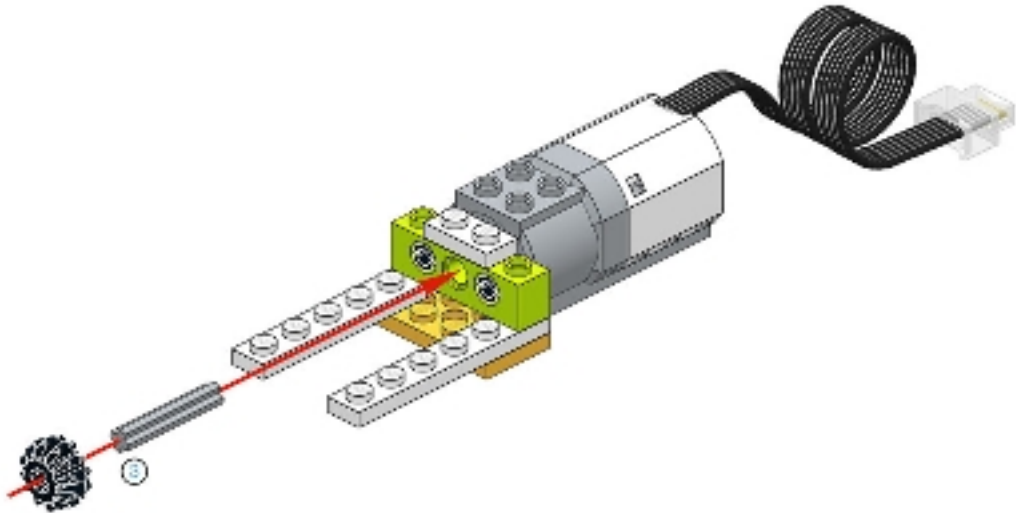

9

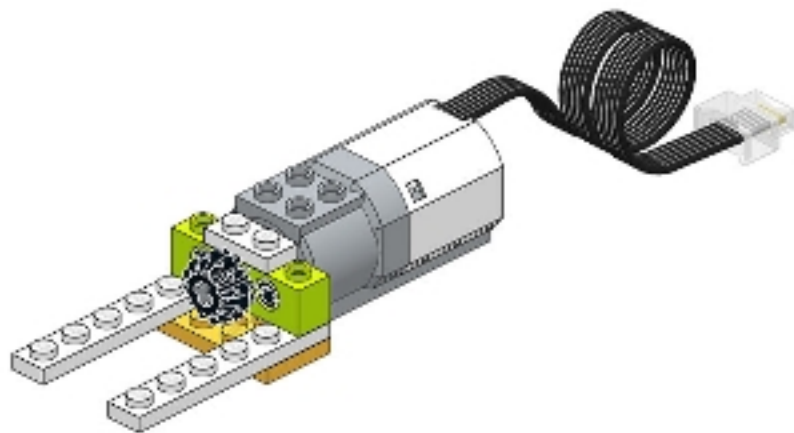



1x

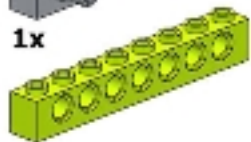

1x

10

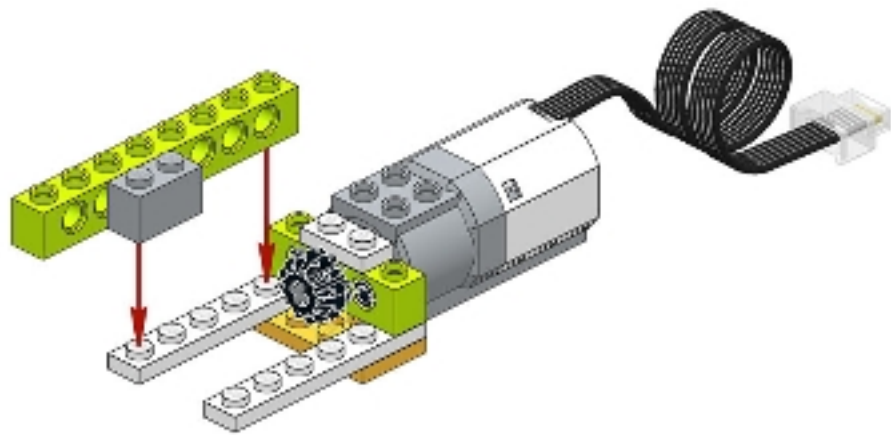



1x

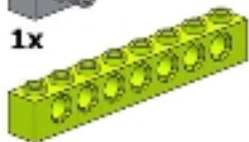

1x

11

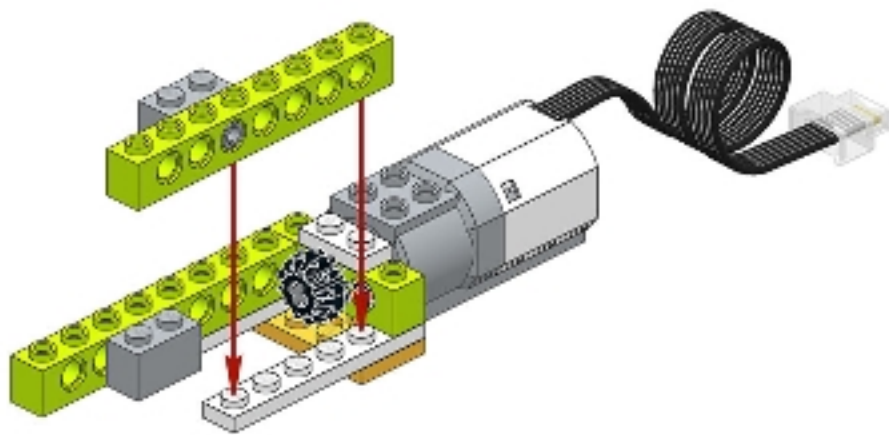

12

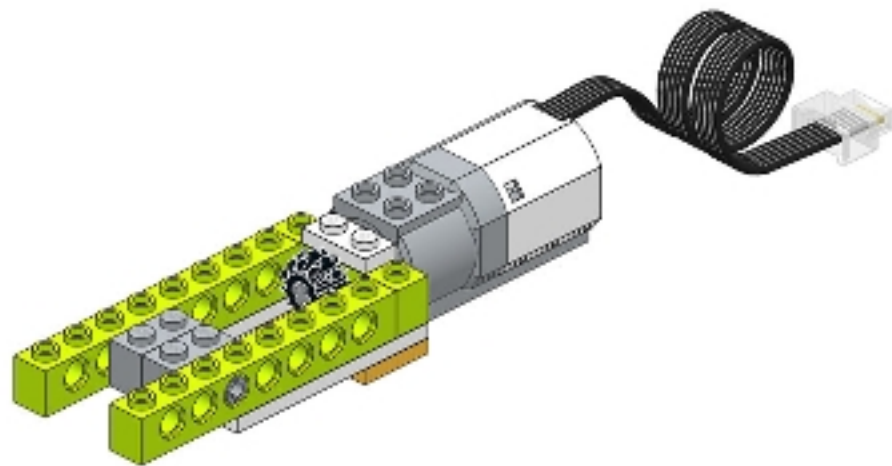



1x

13

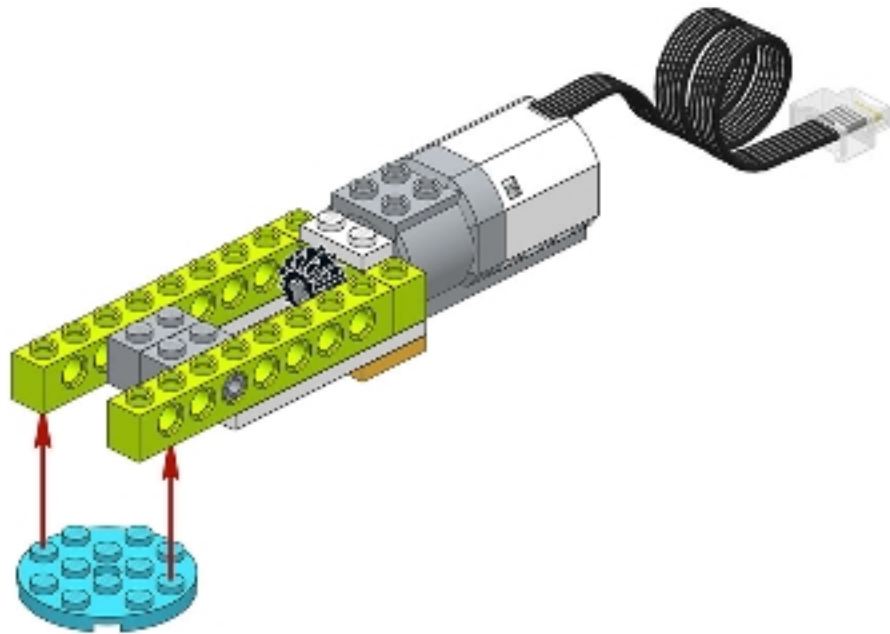

14

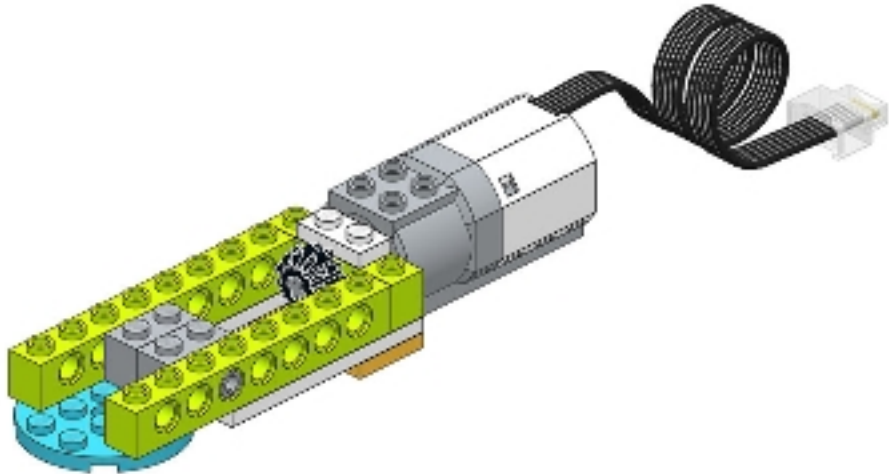

1x

1x

15

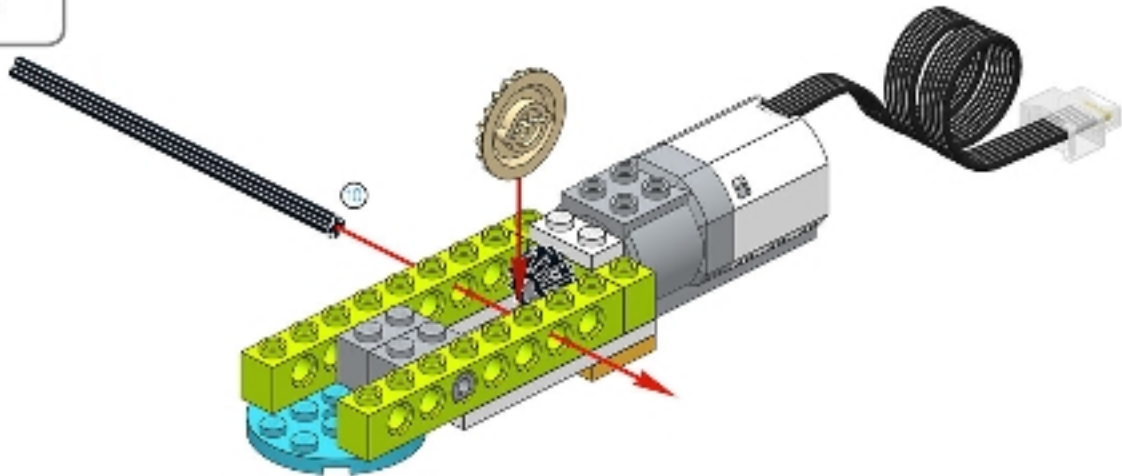

16

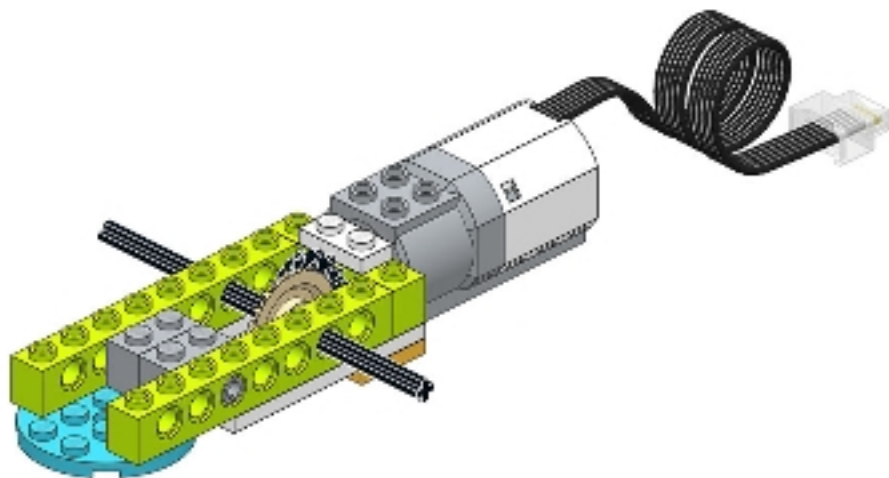



2x

17

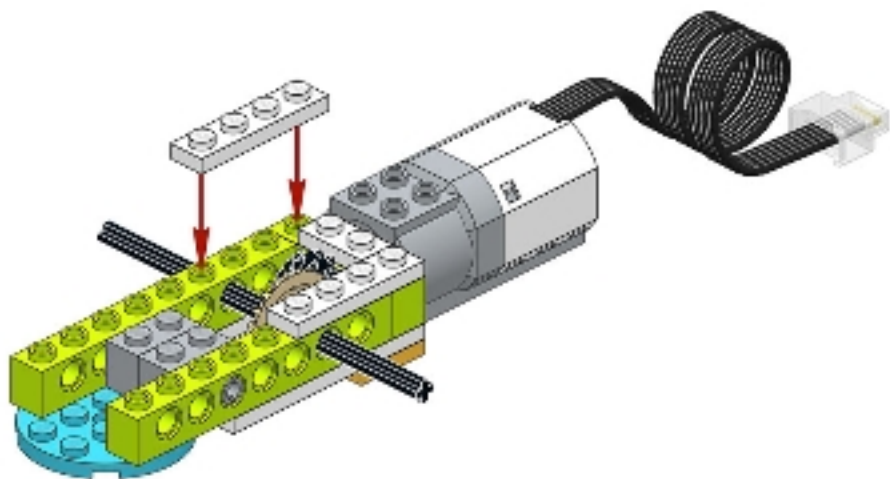



1x

18

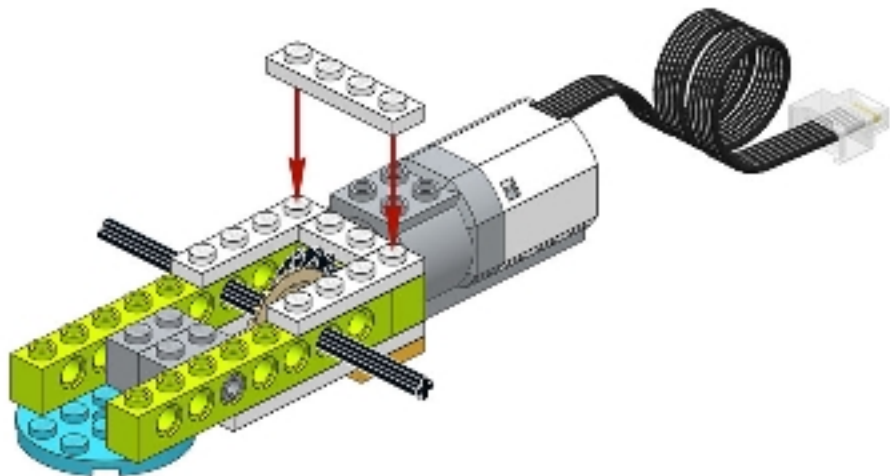

20

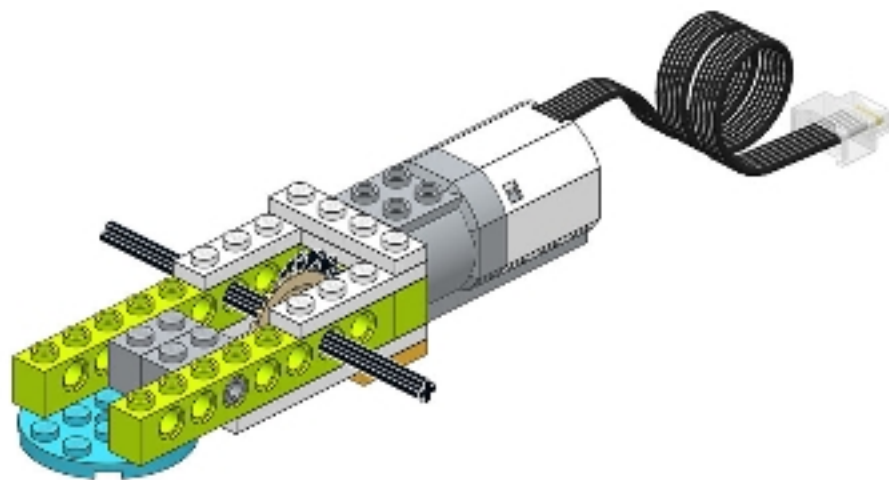

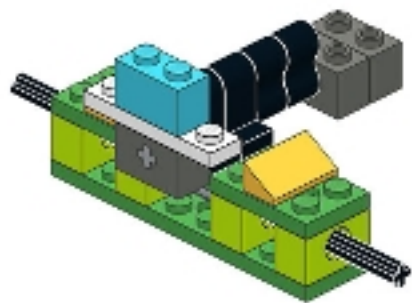

4x



1x

21

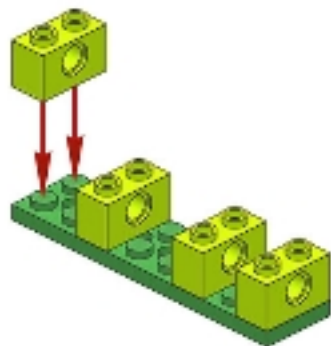

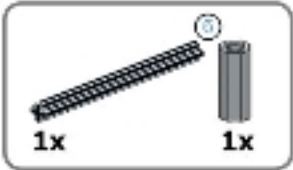

22

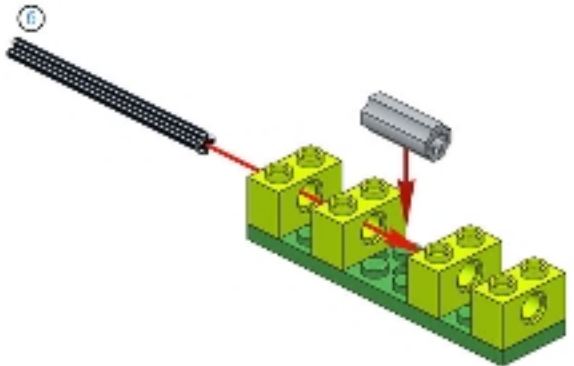

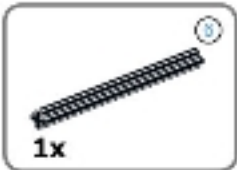

23

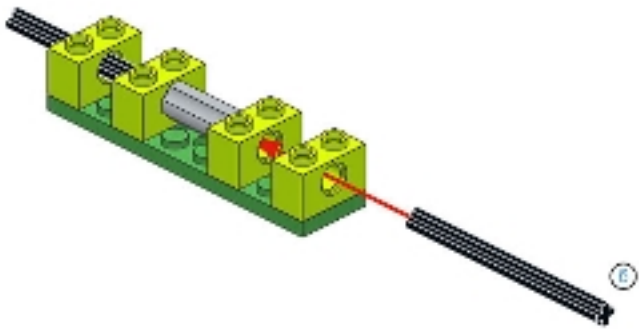

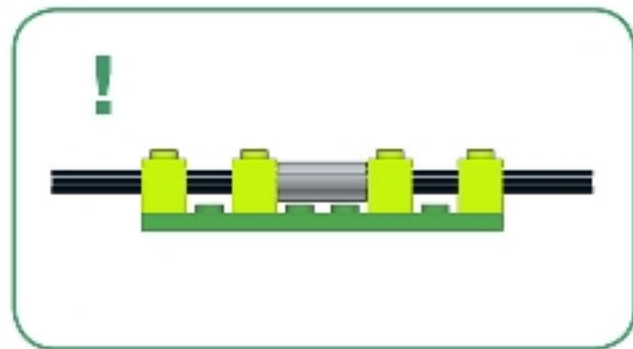
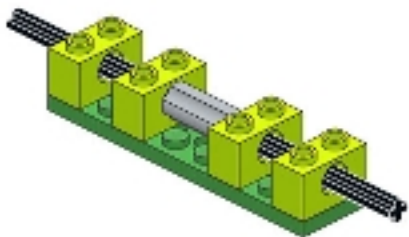

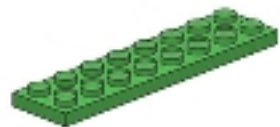

1x

25

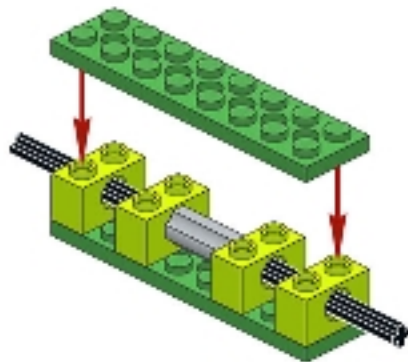

26

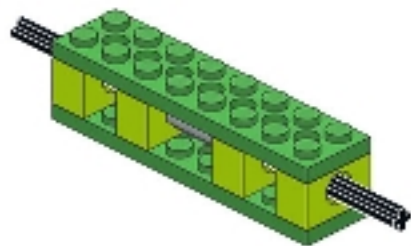



2x

26

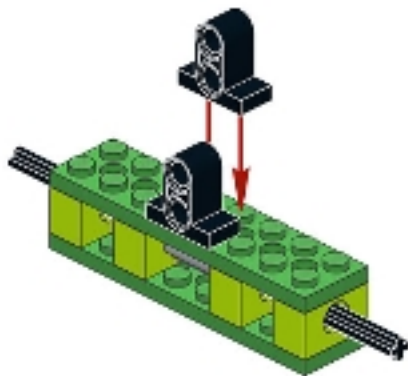



2x

27

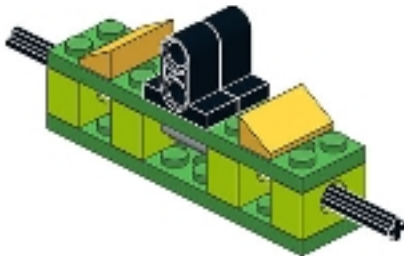

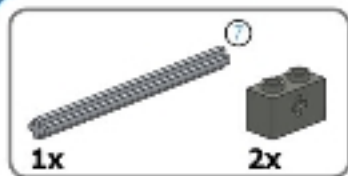

1

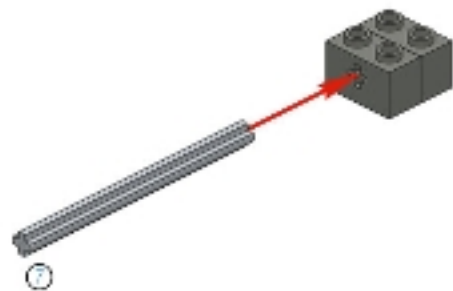

2

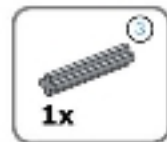

3

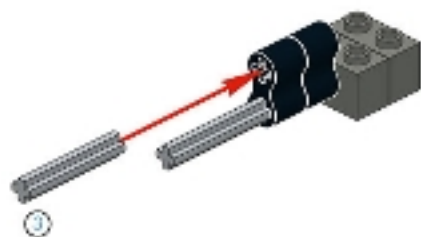

4

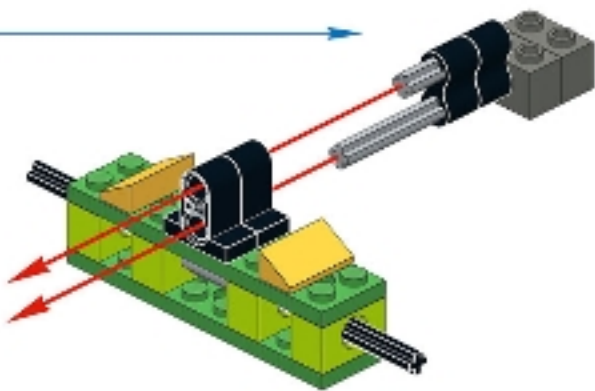

30

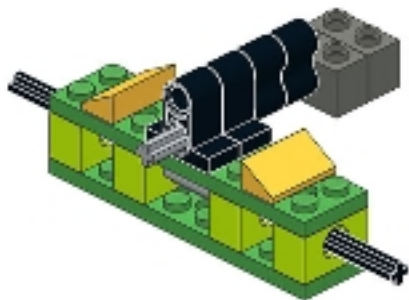



1x



1x

1

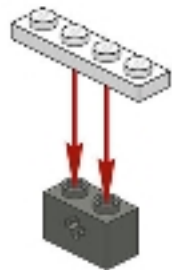

1x

2

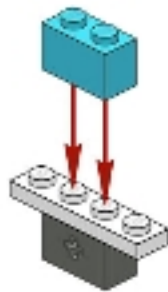

3

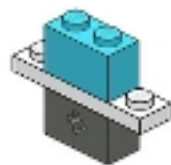

32

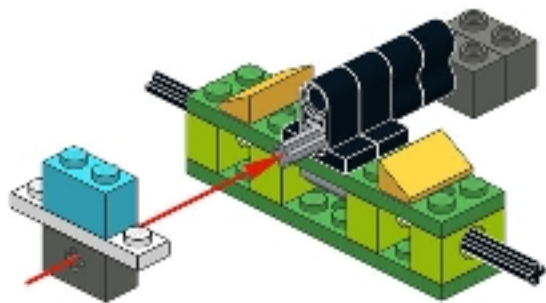

33

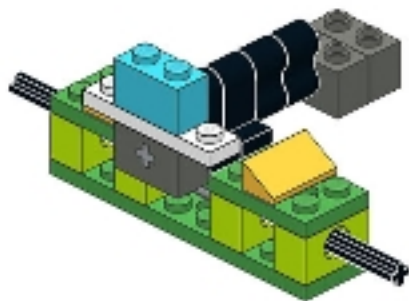

34

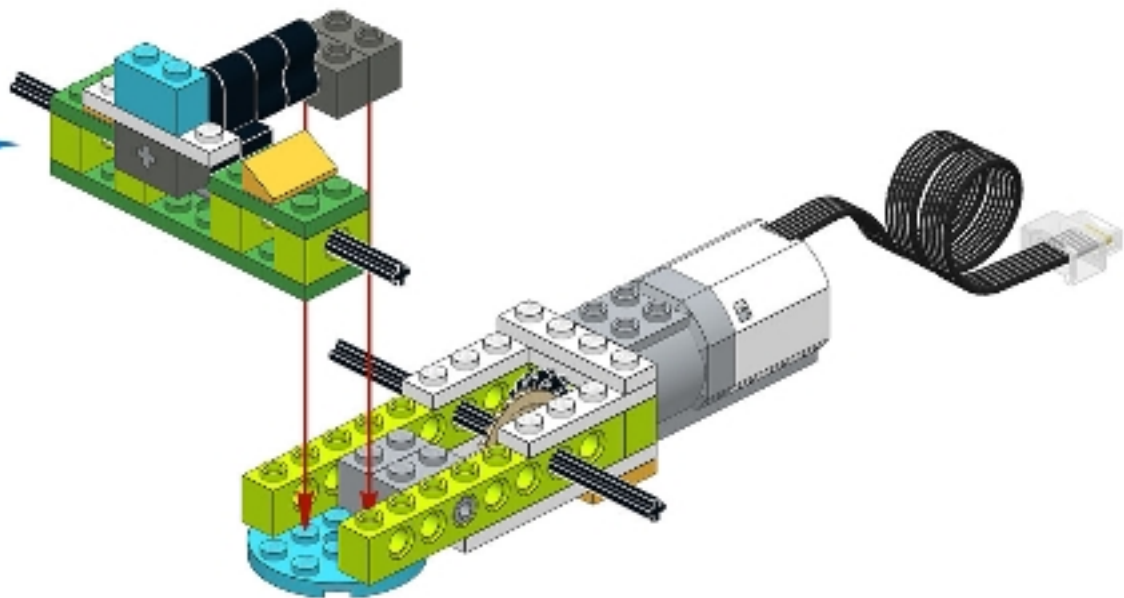

35

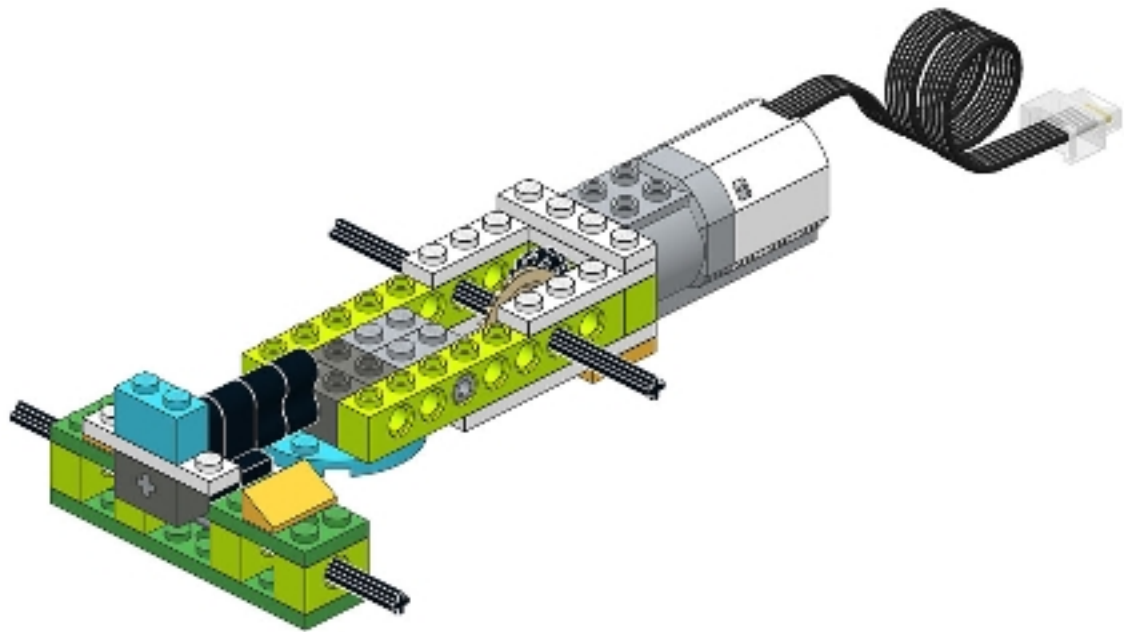



1x

36

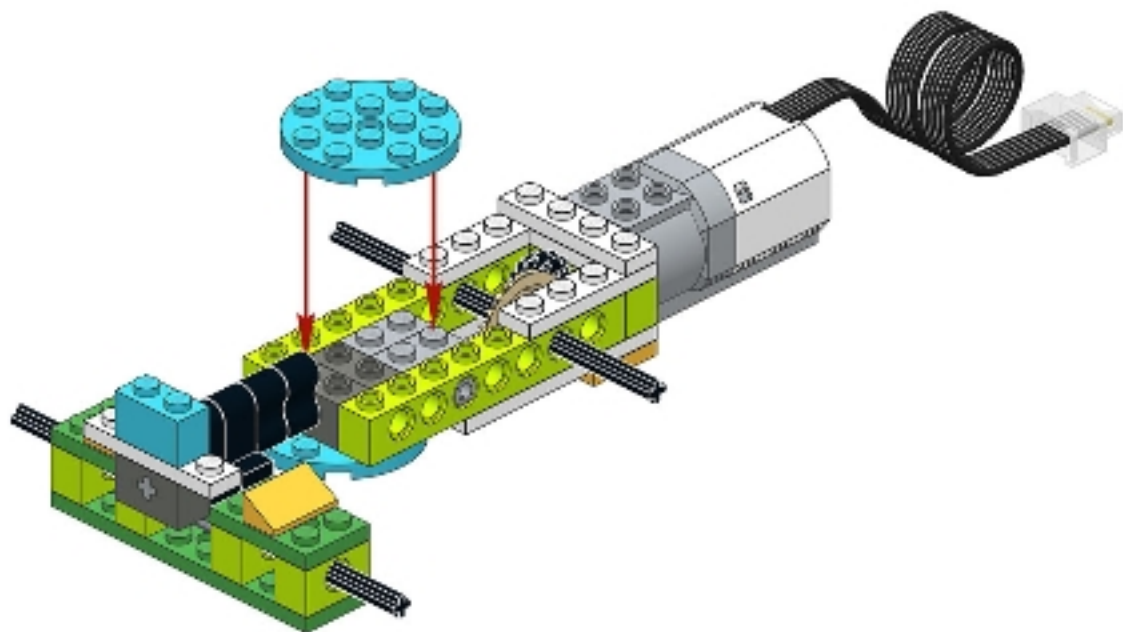

37

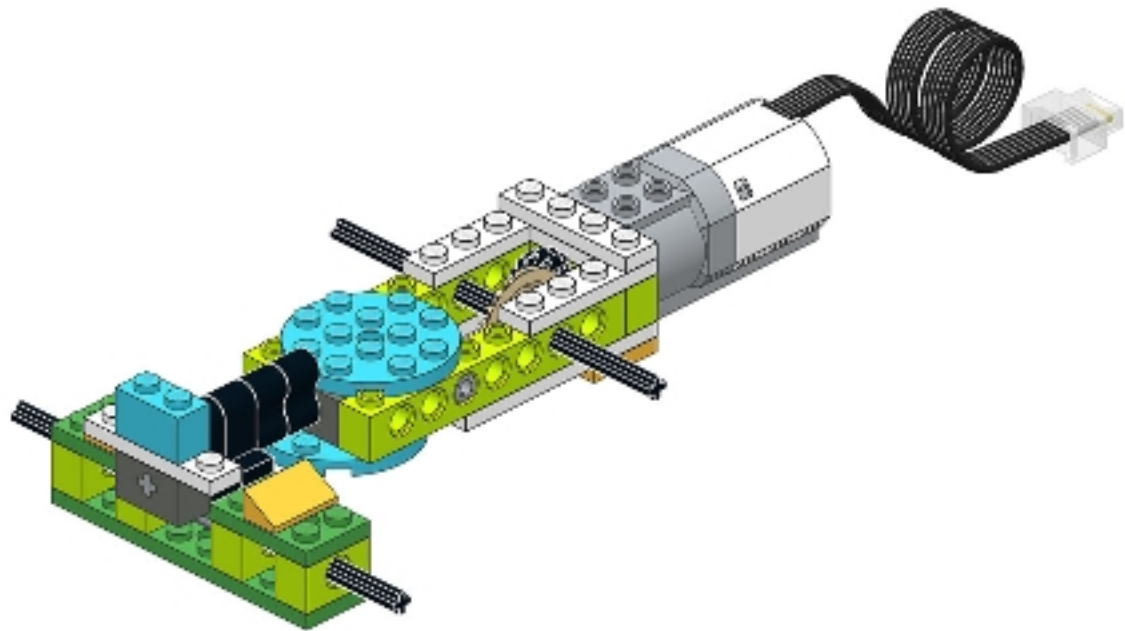

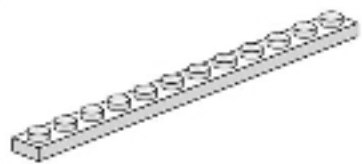

2x

38

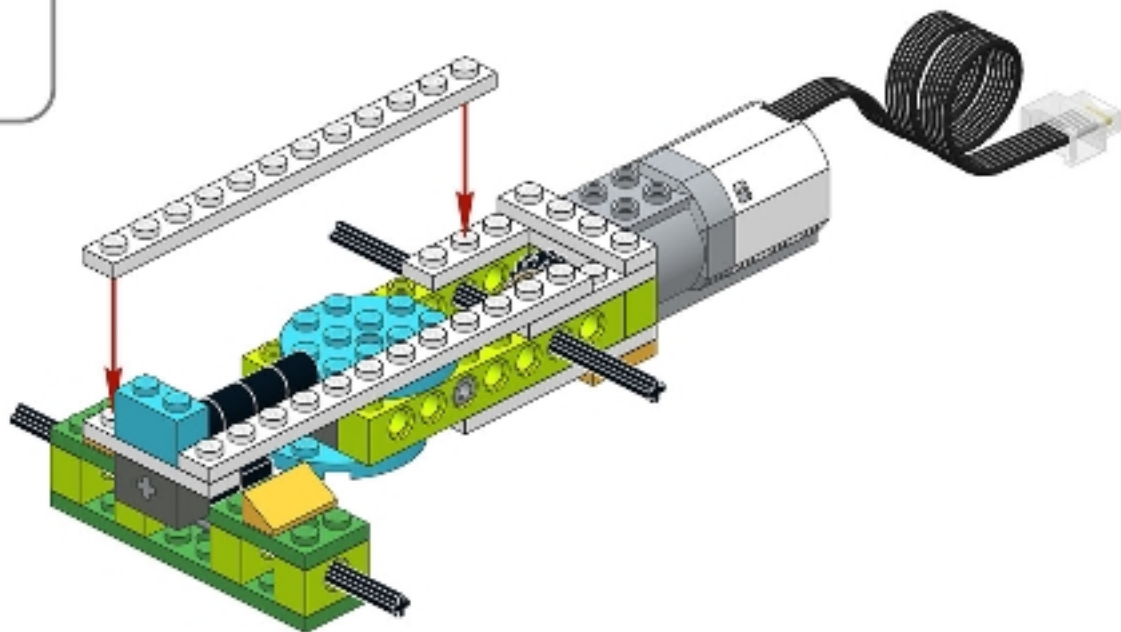

39

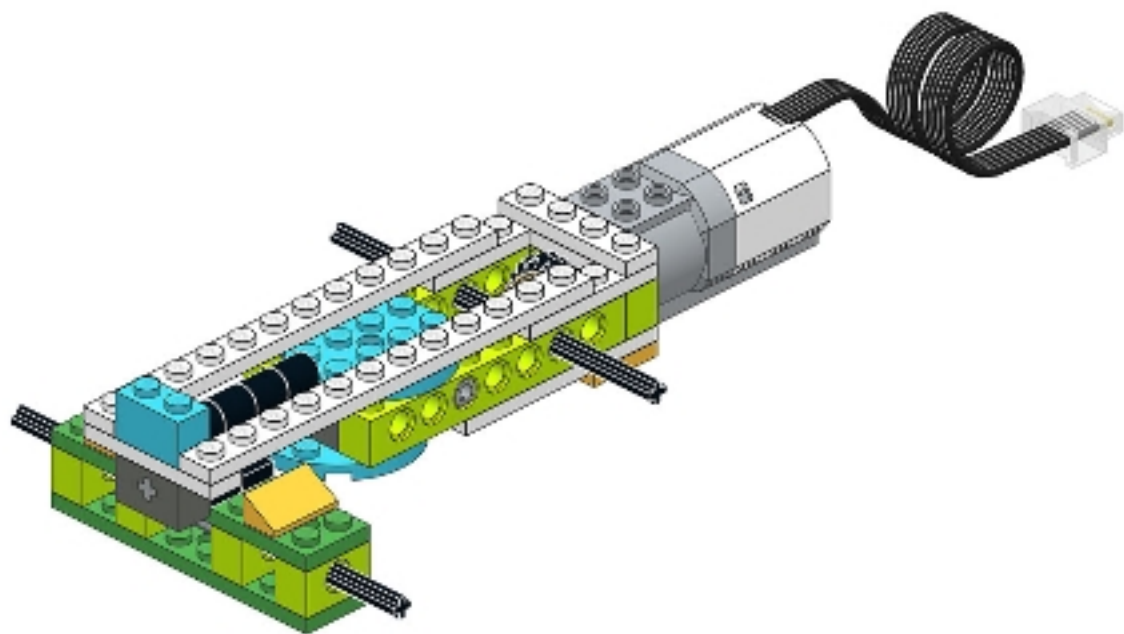



2x

40

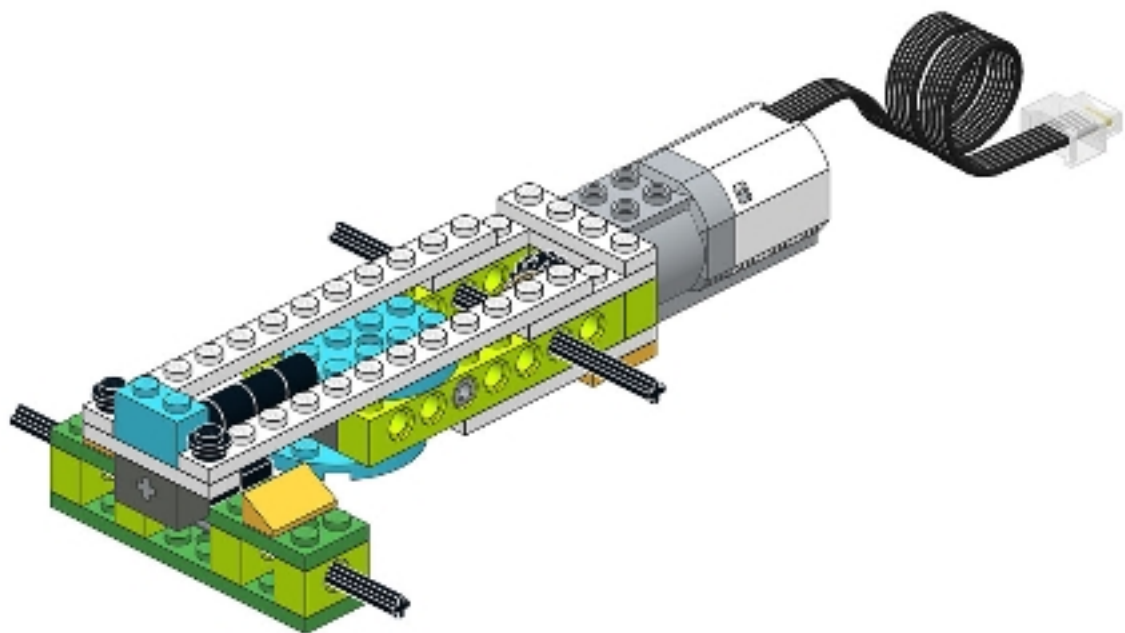



2x

41

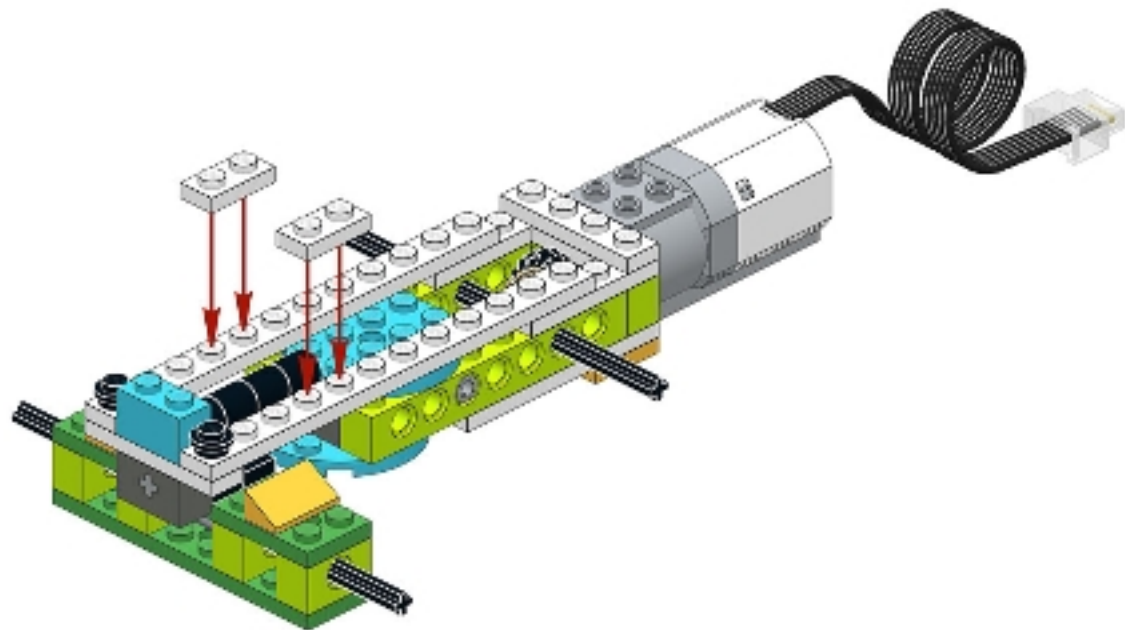

42

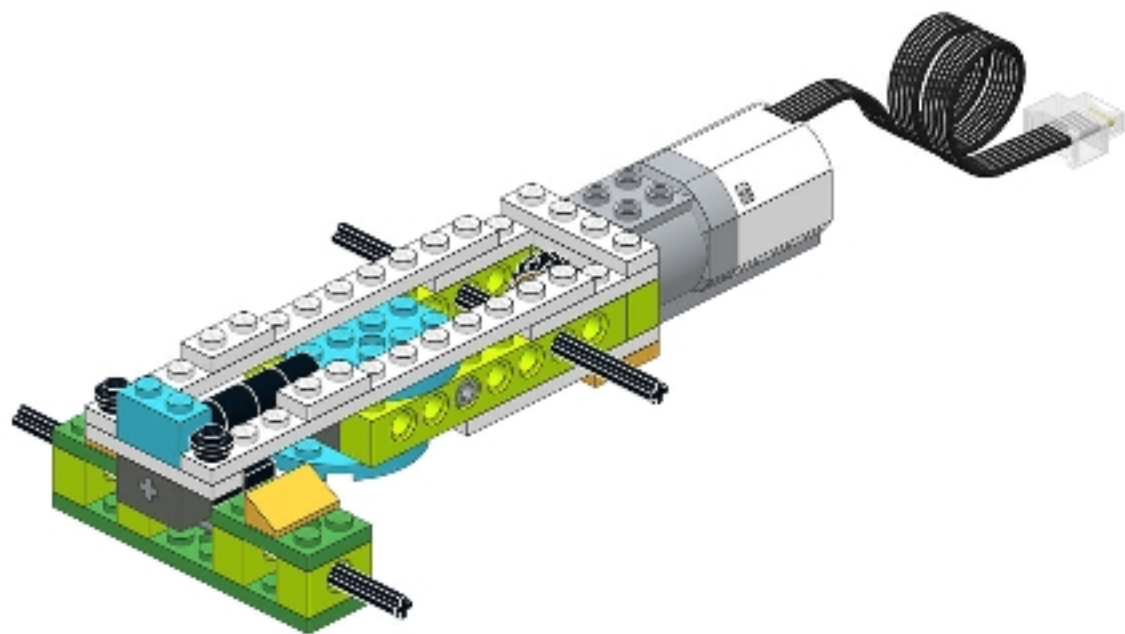



1x

43

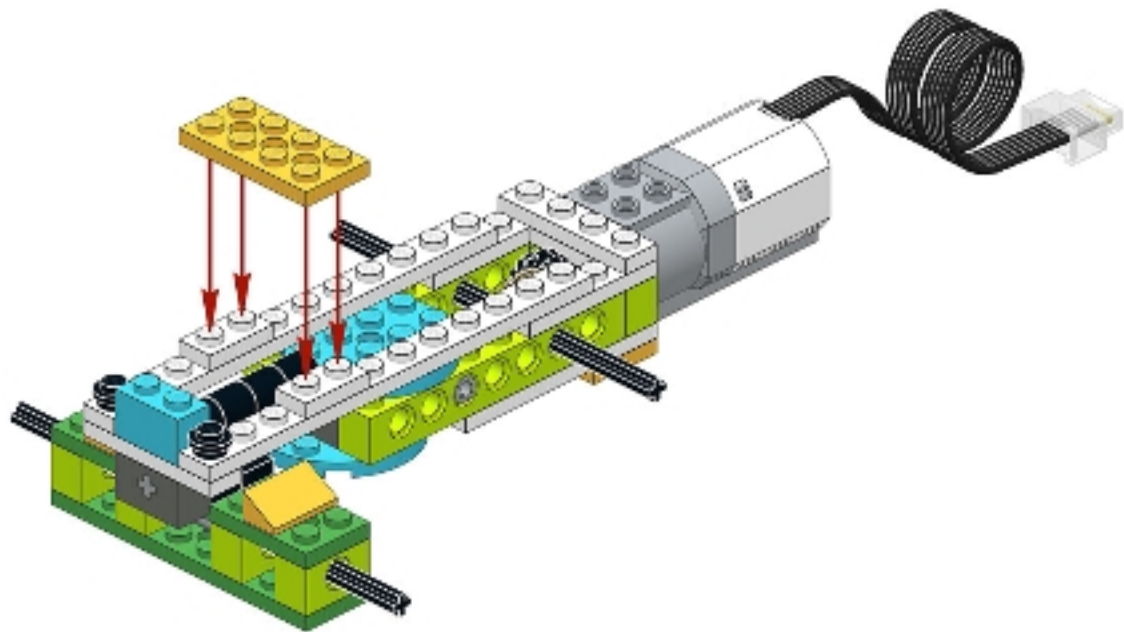

44

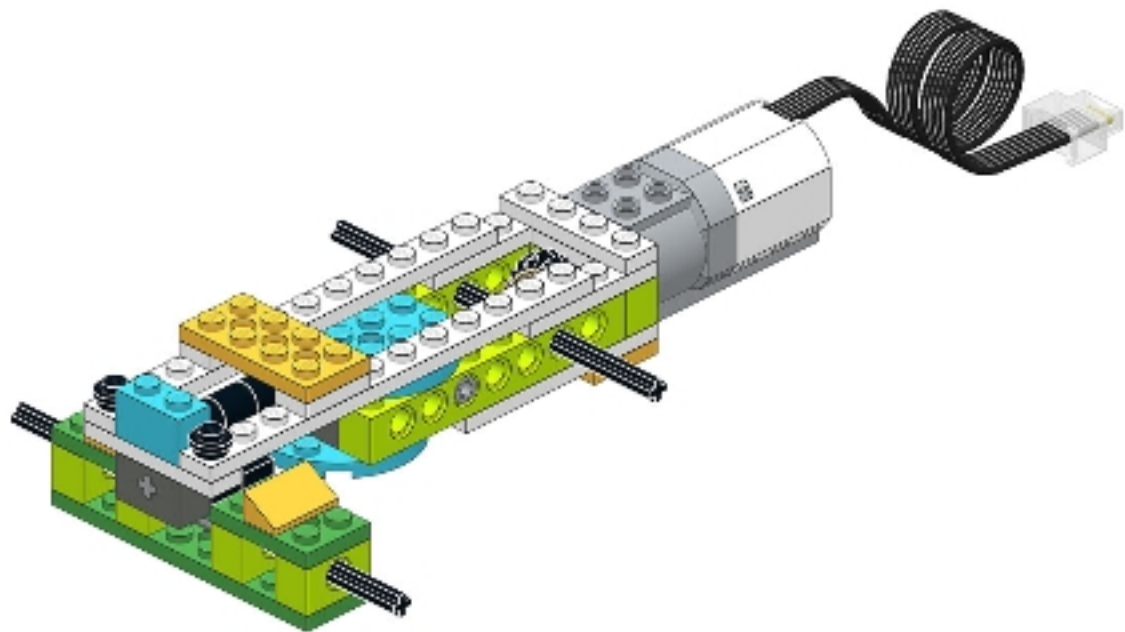



2x

45

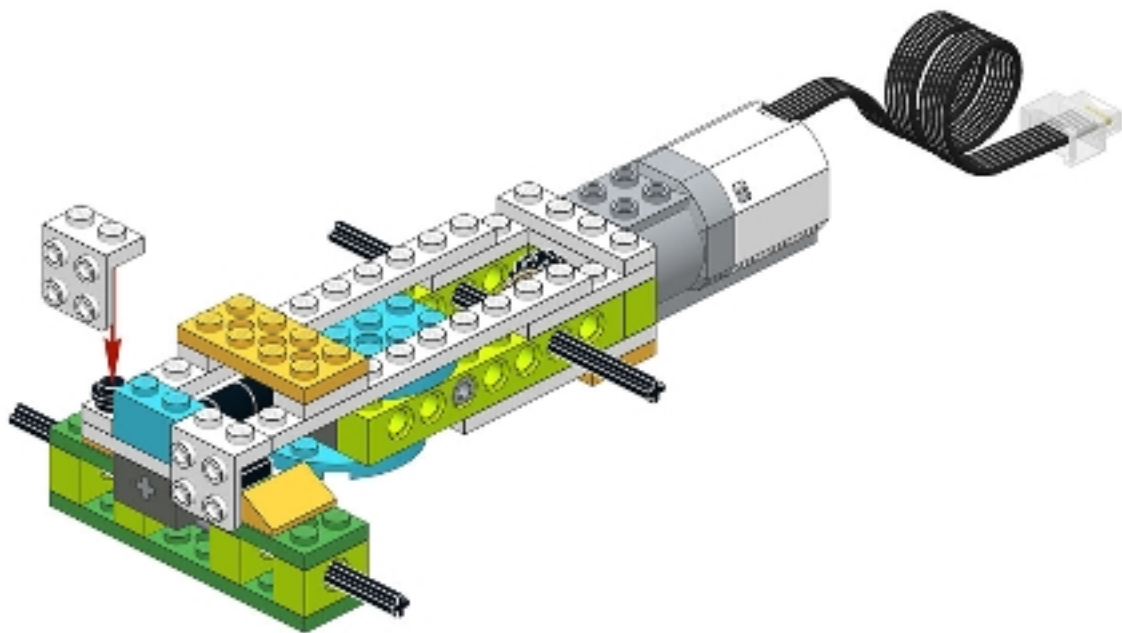

46

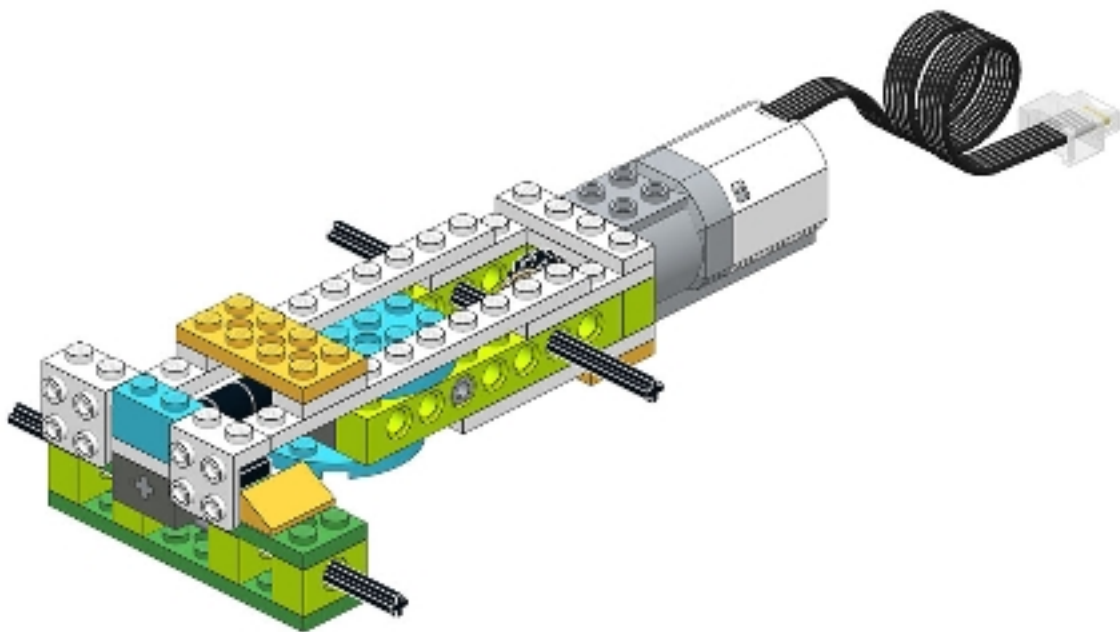

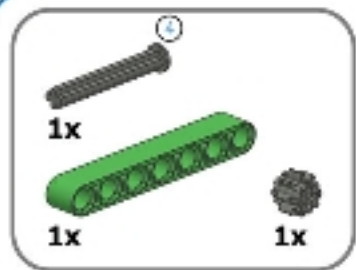

1

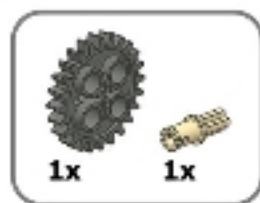
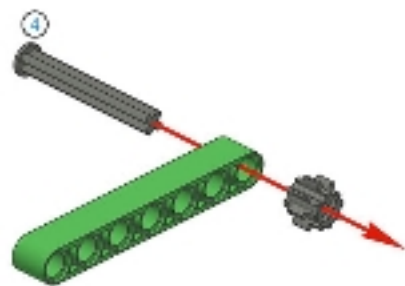

2

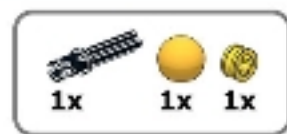
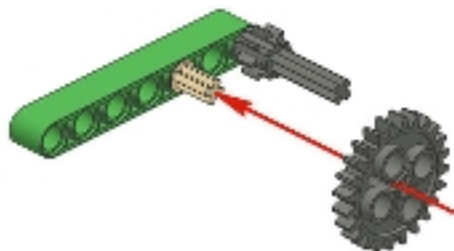

3

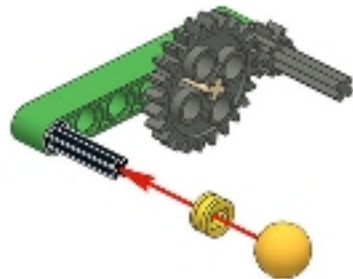



4

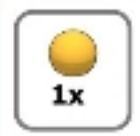
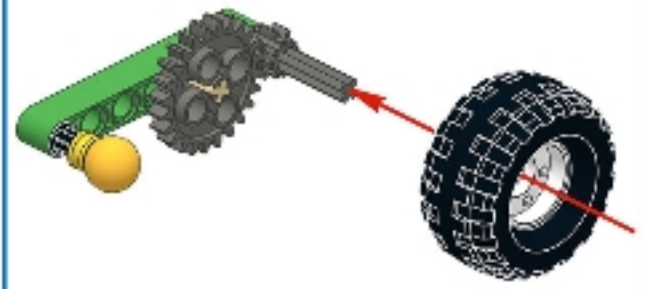

5



6



2x

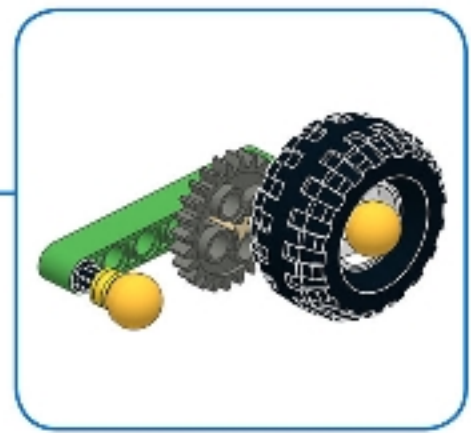
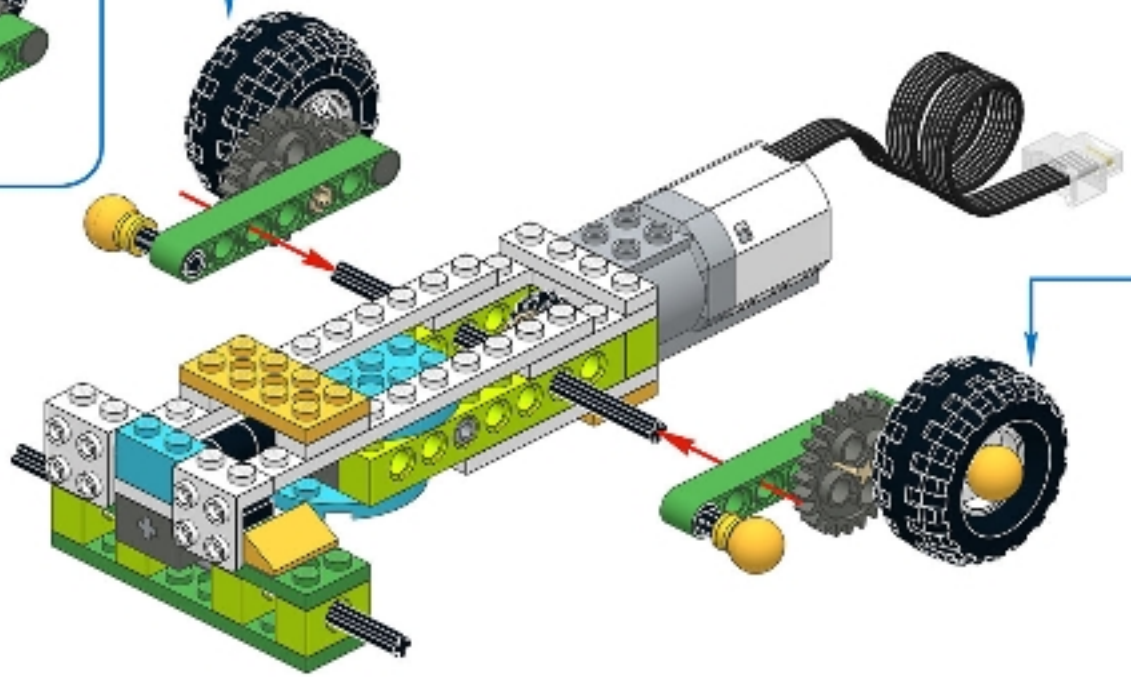
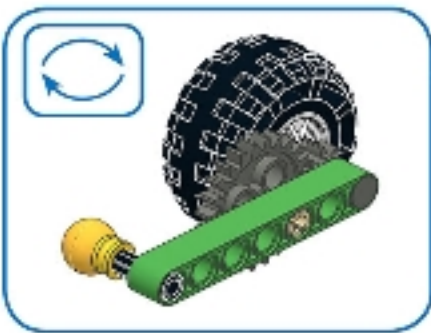

50

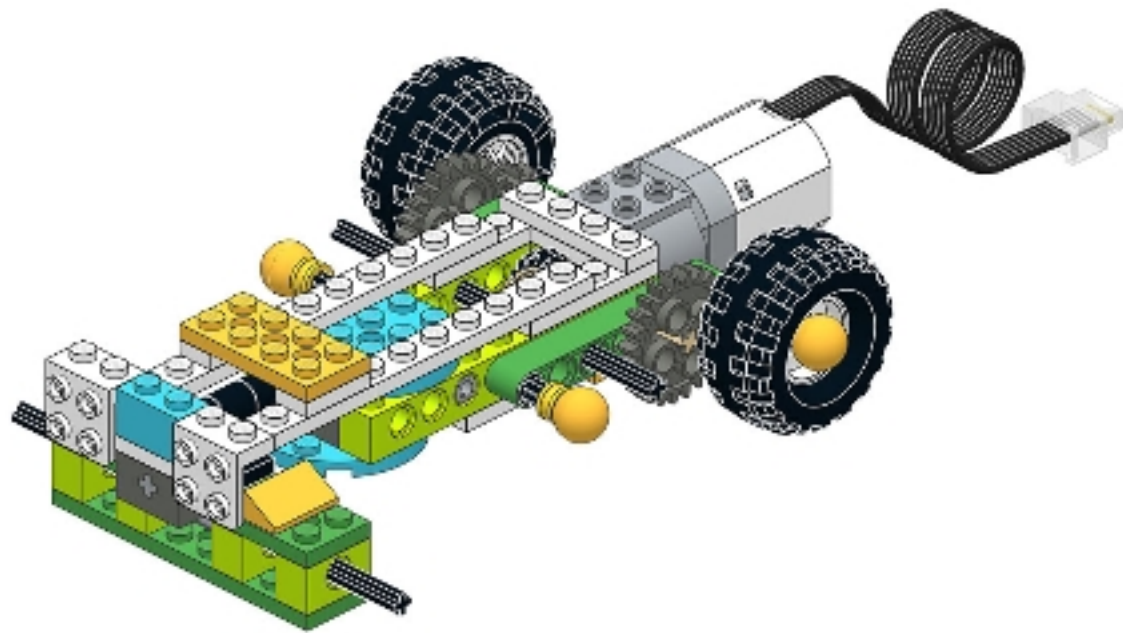

2x 2x

51

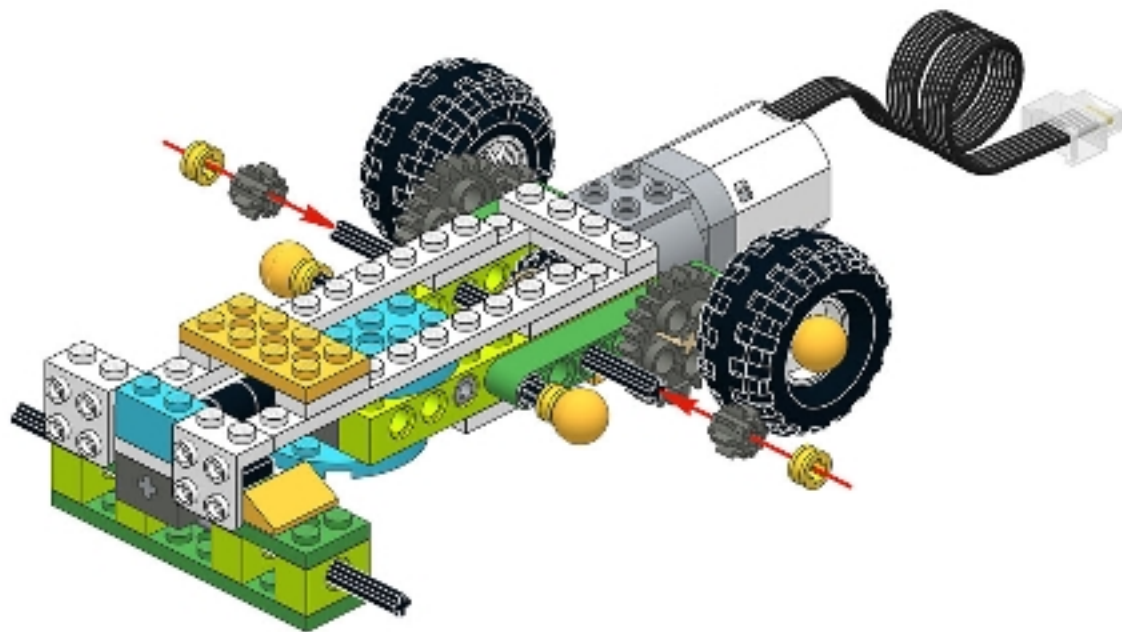

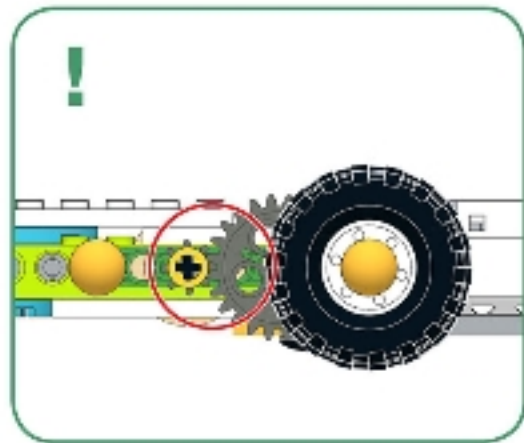
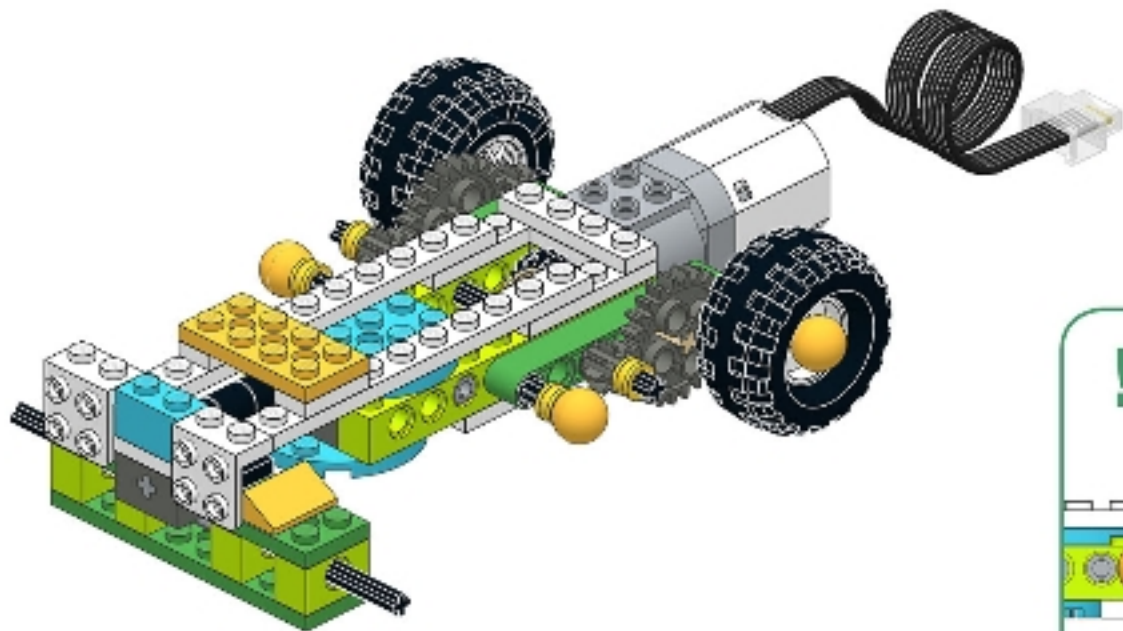



2x

53

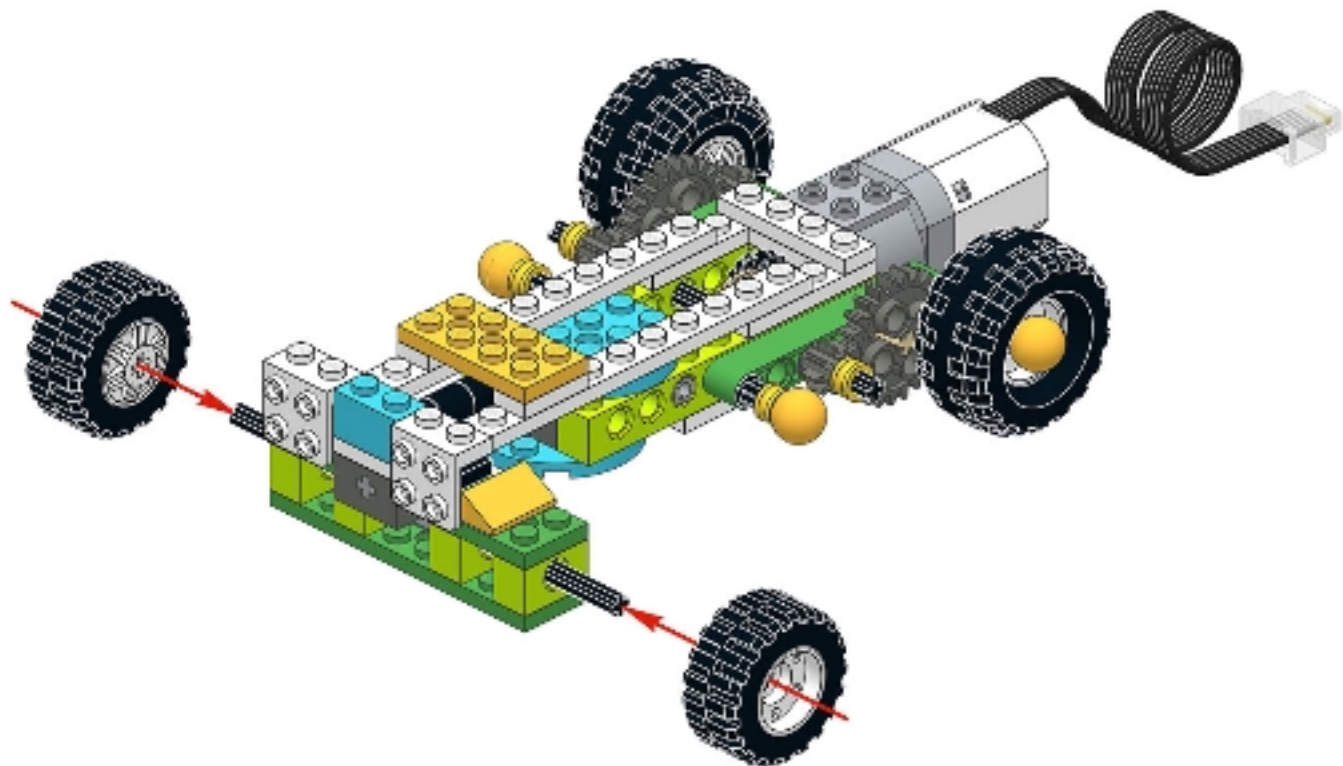



2x

54

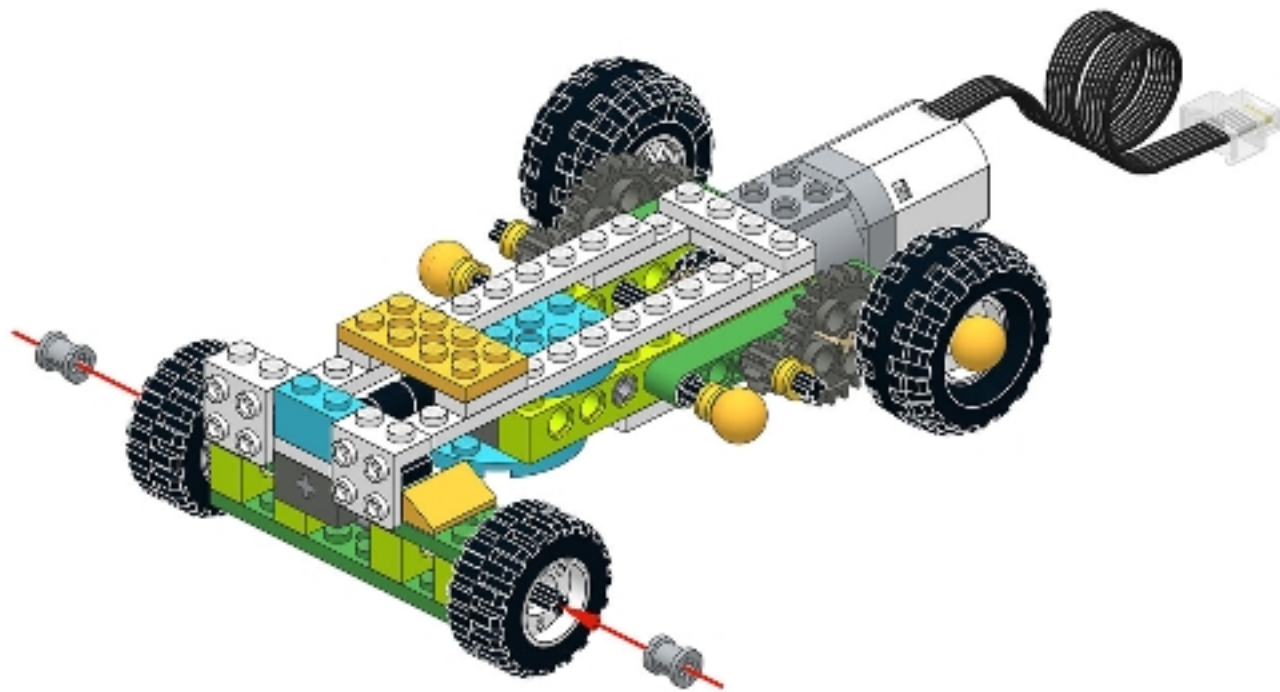

55

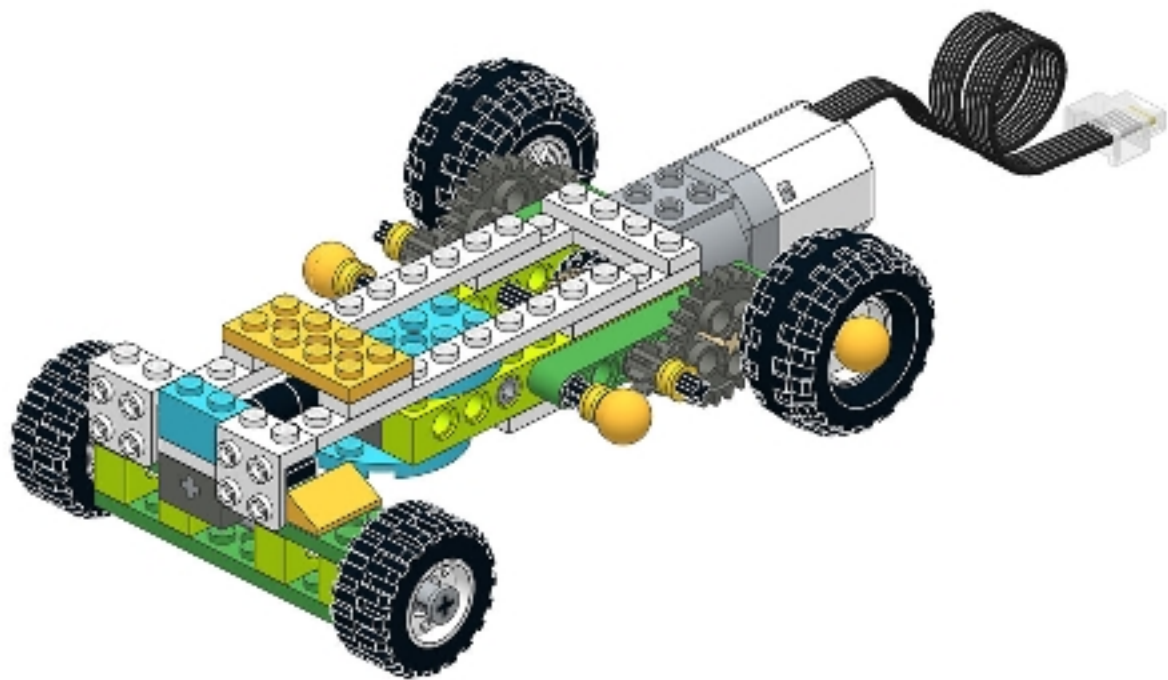

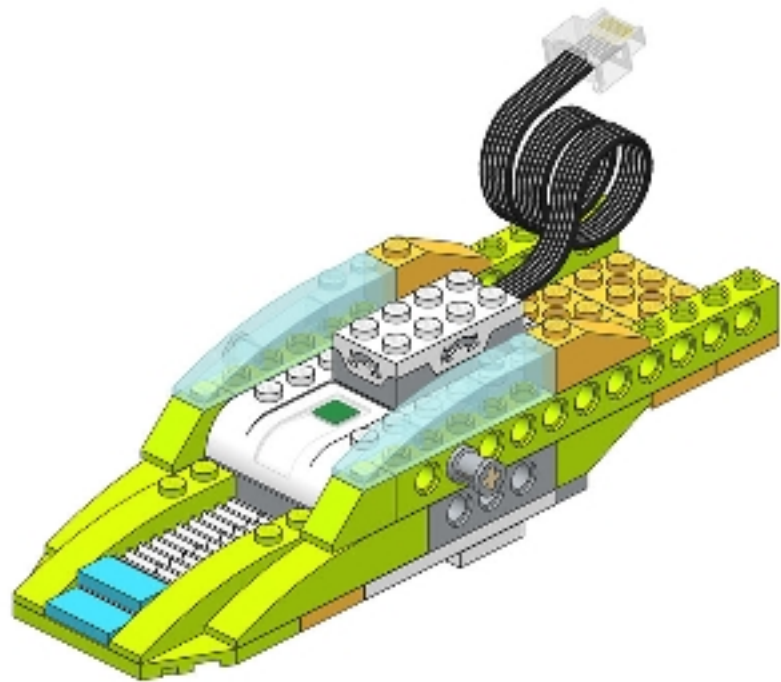

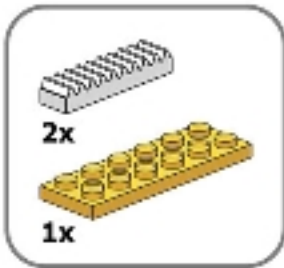

57

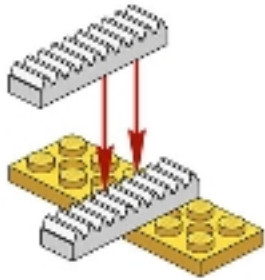



1x

58

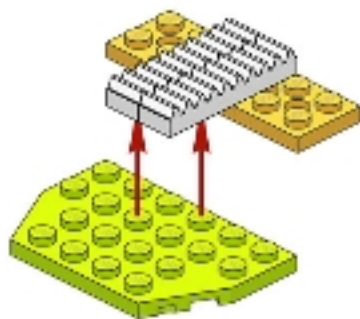



1x

59

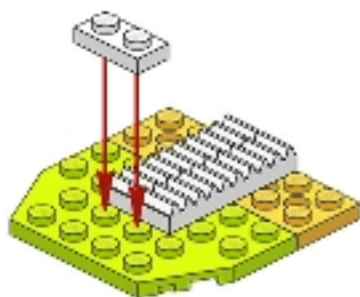



2x

60

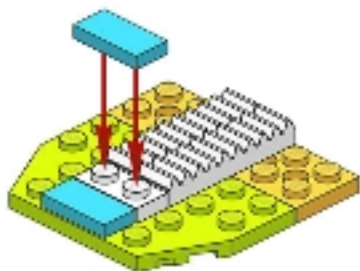

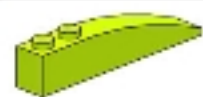

2x

61

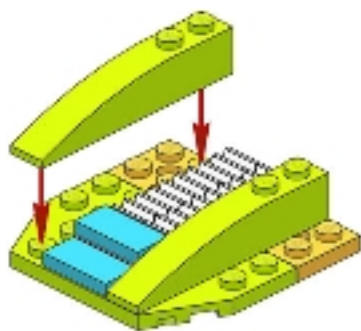



2x

62

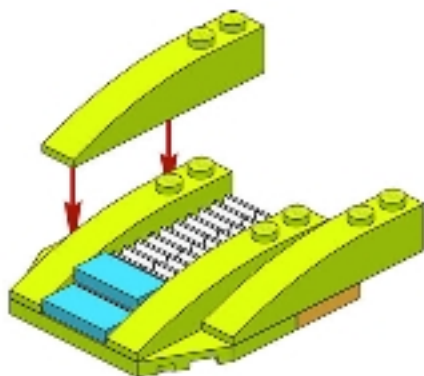

63

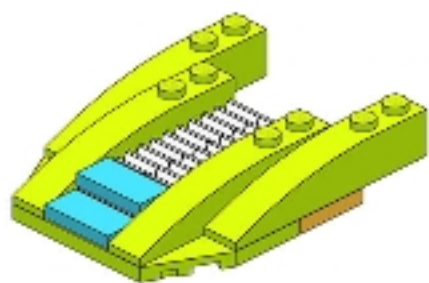

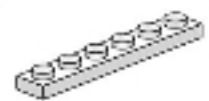

2x

64

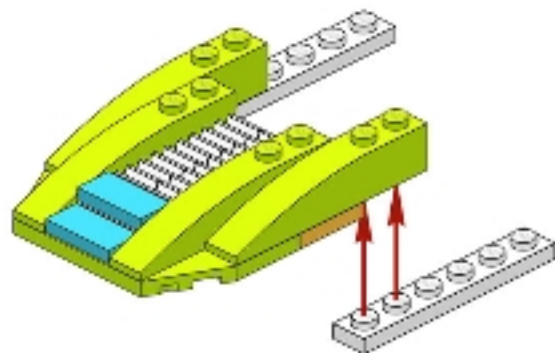



2x

65

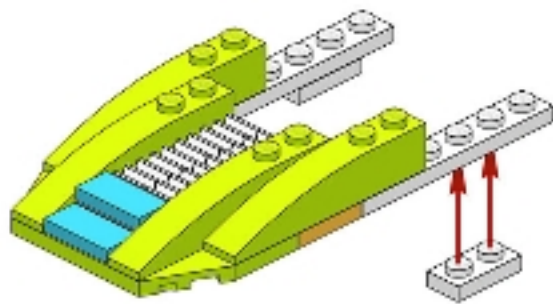

66

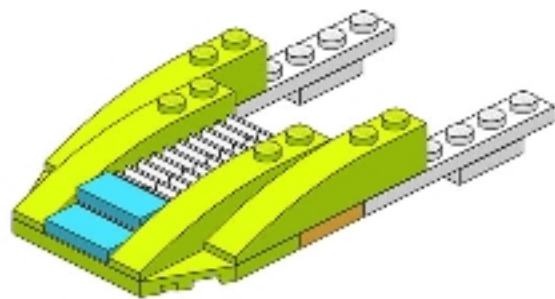

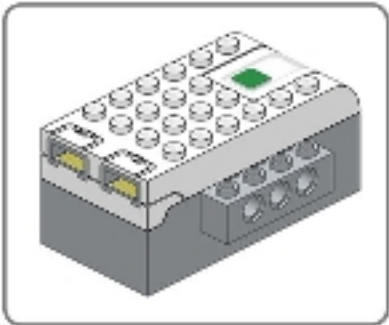

67

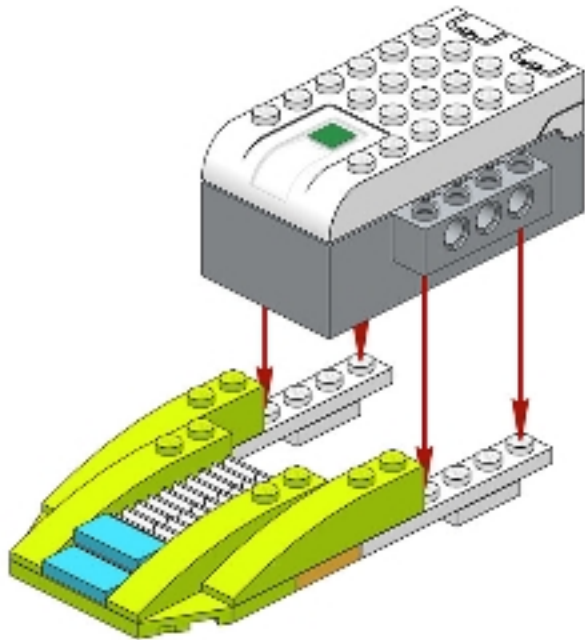

68

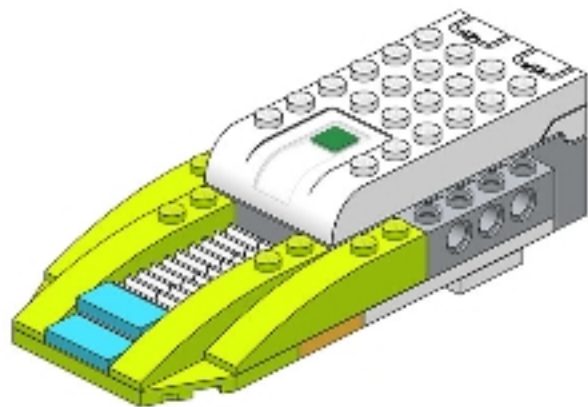

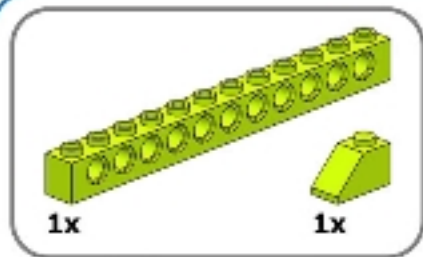

1

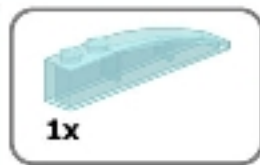
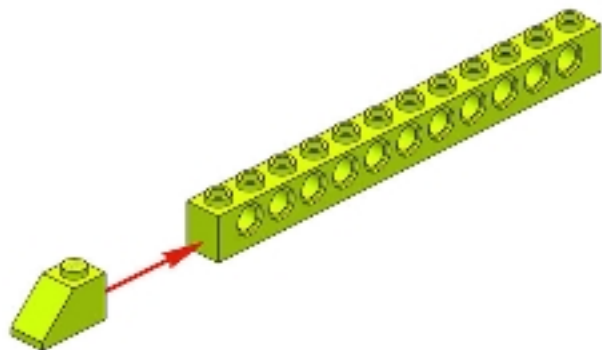

2

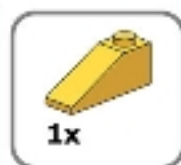
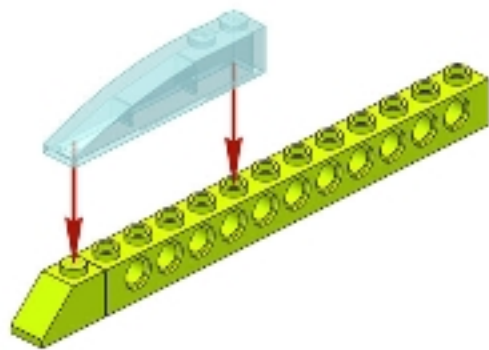

3

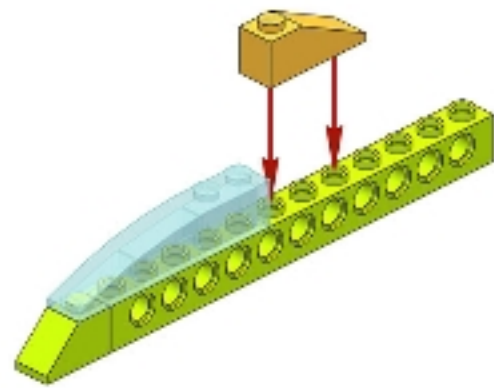

4

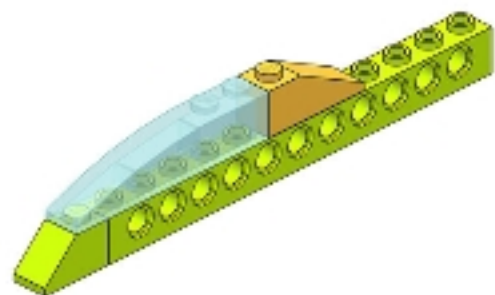

2x



2x

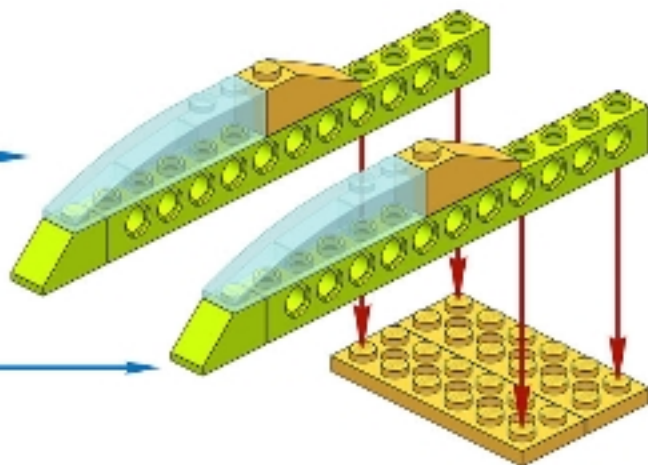

71

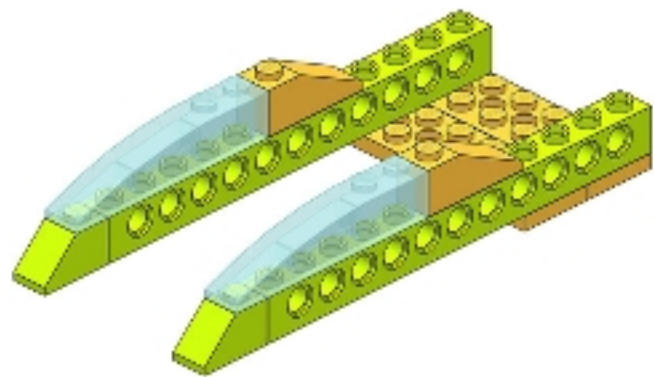



2x

72

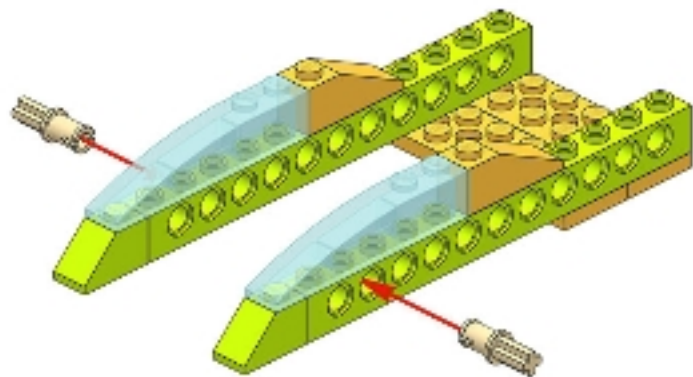



2x

73

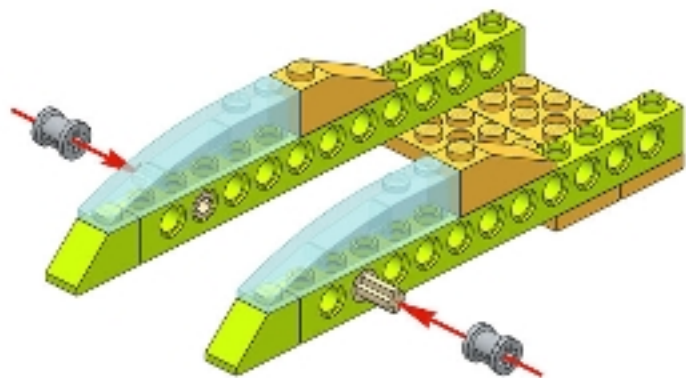



2x

74

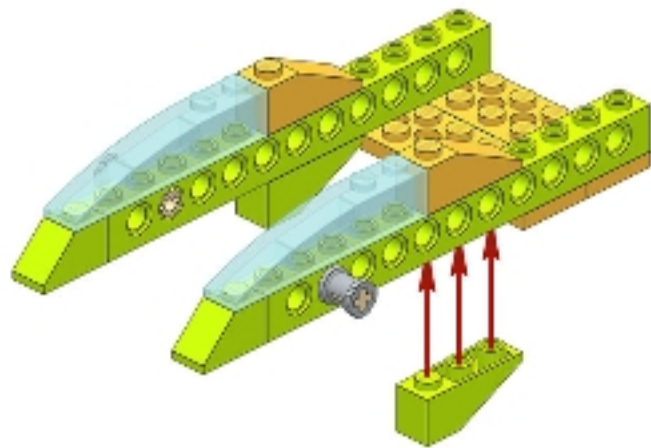

75

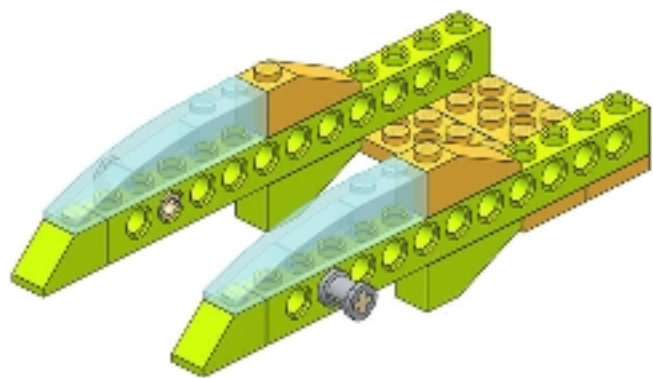

76

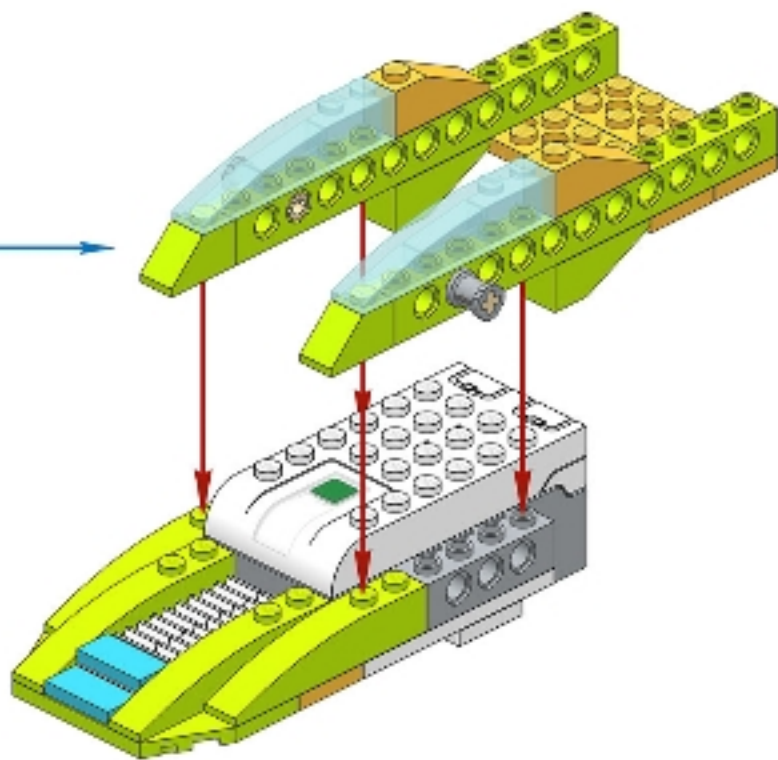

77

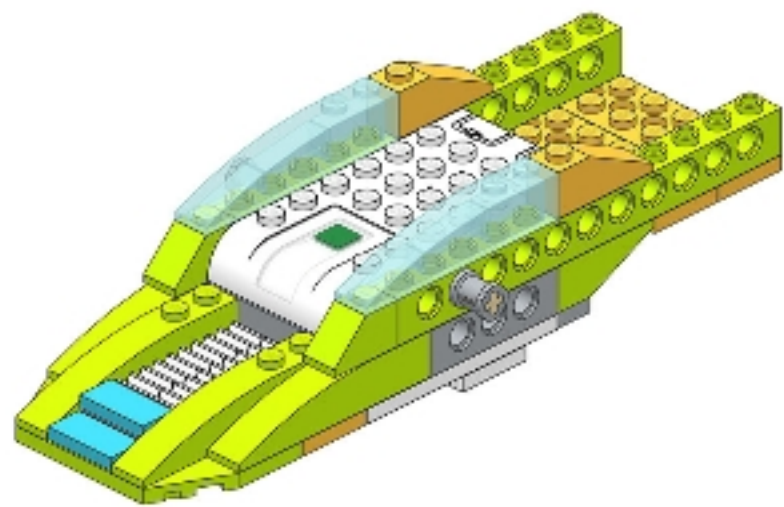

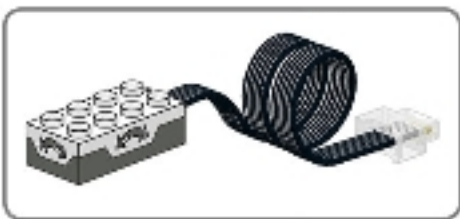

78

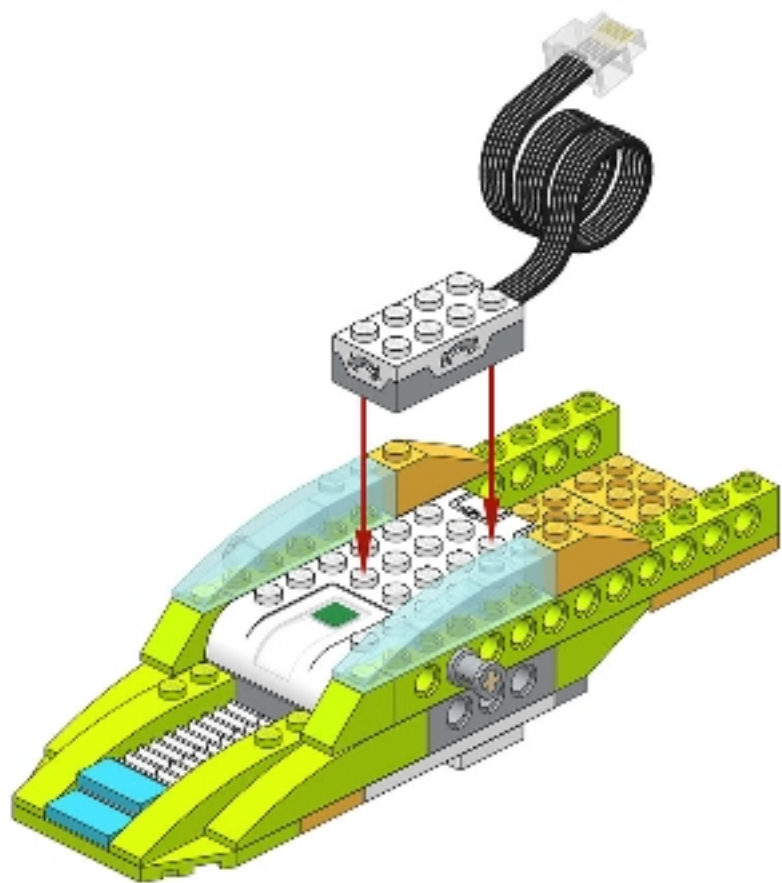

79

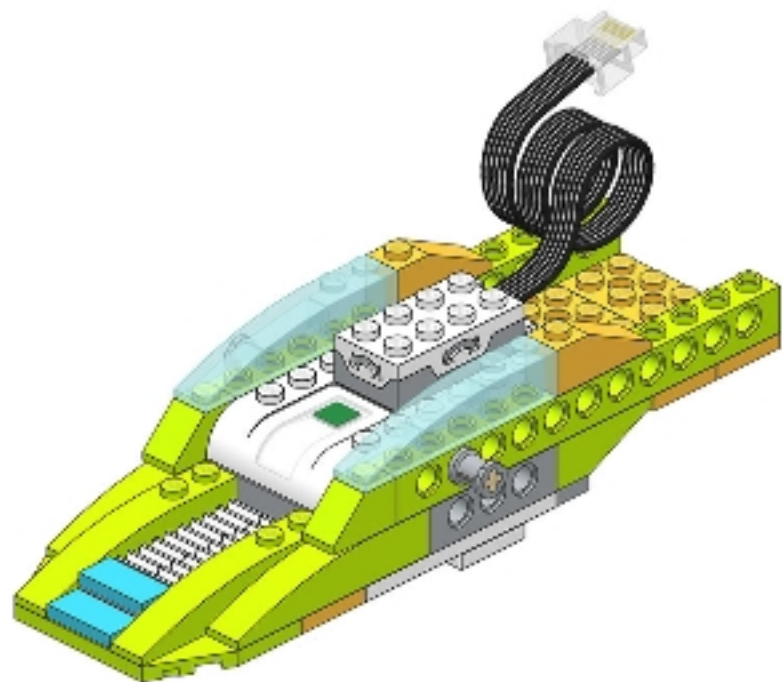

80

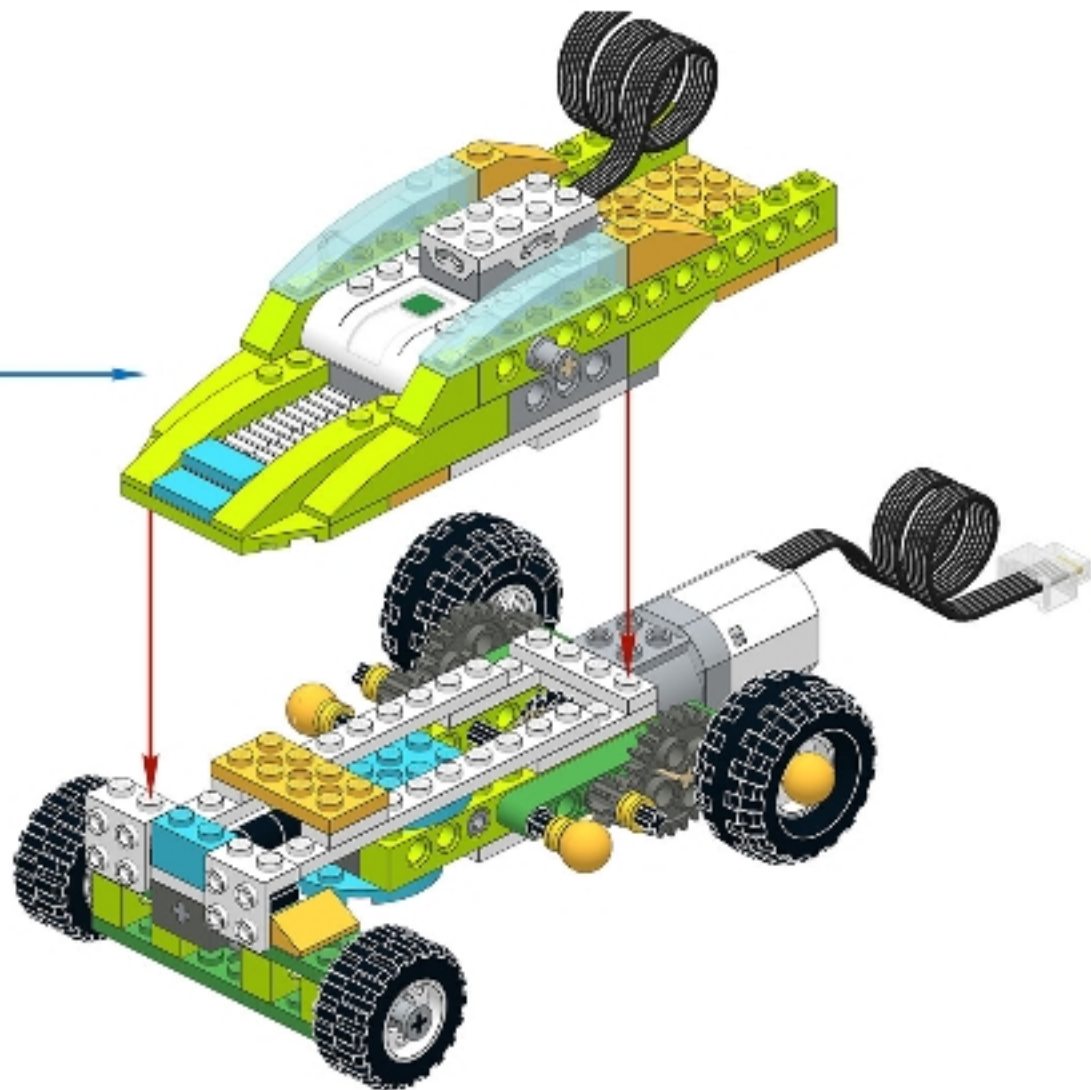

81

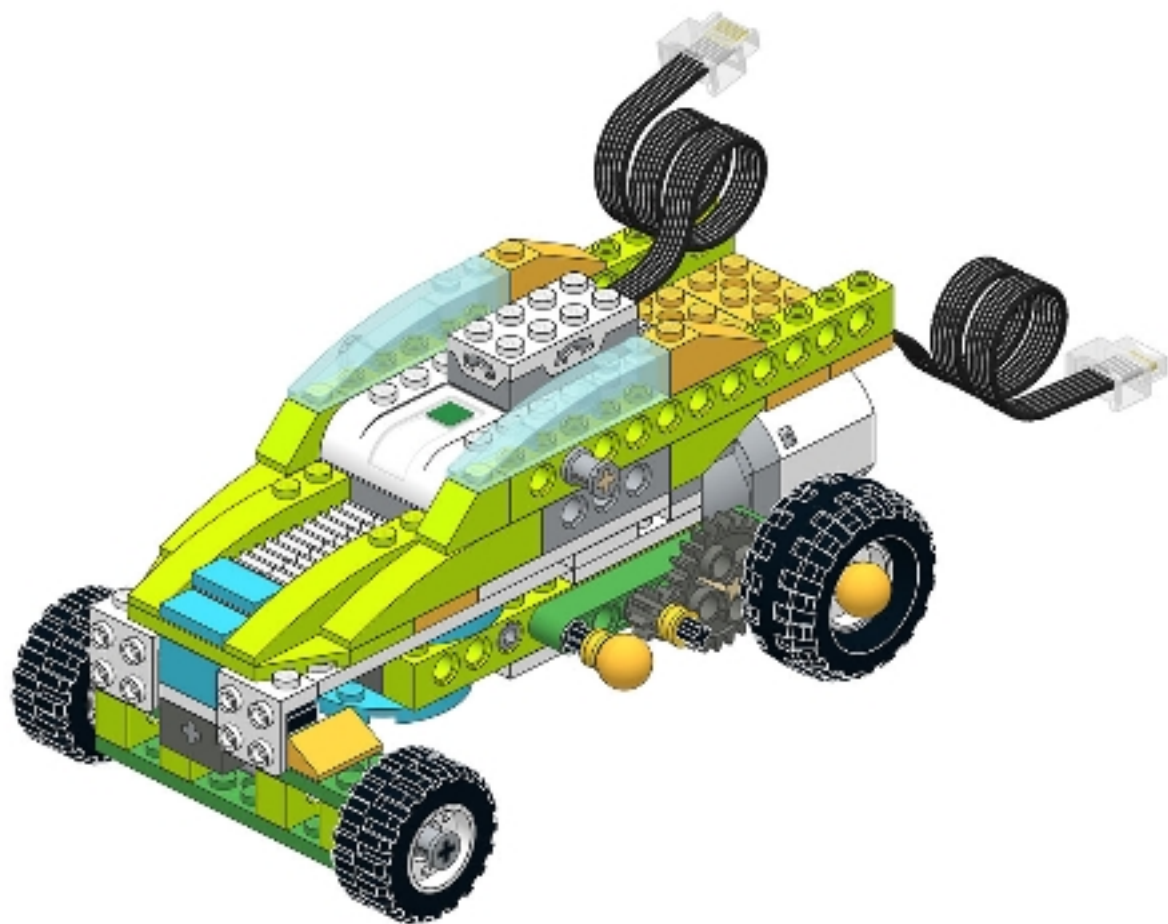

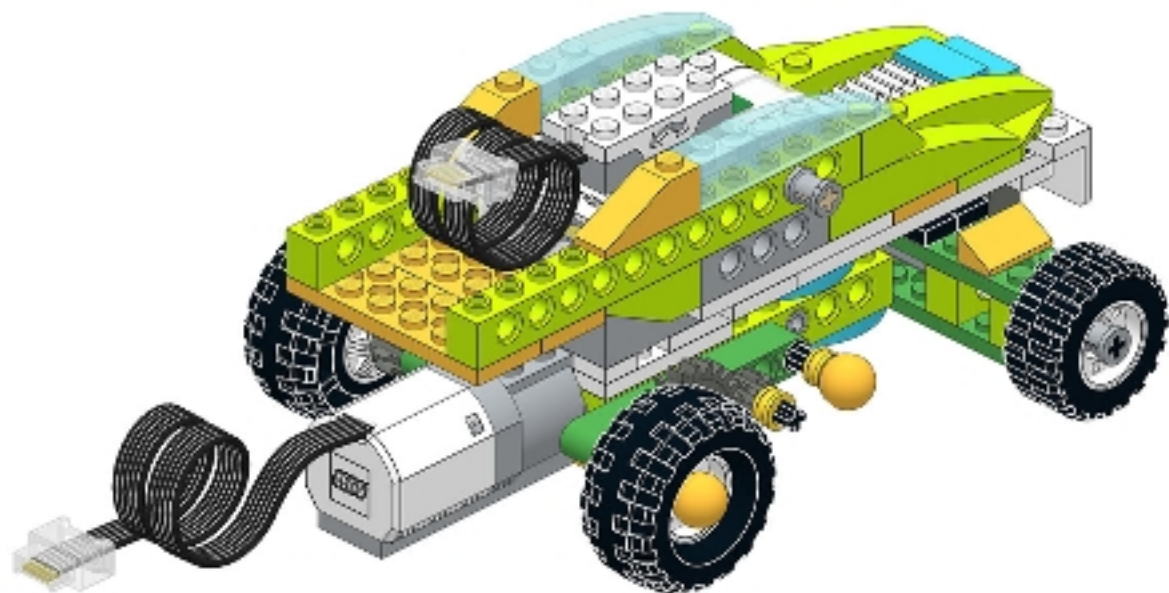

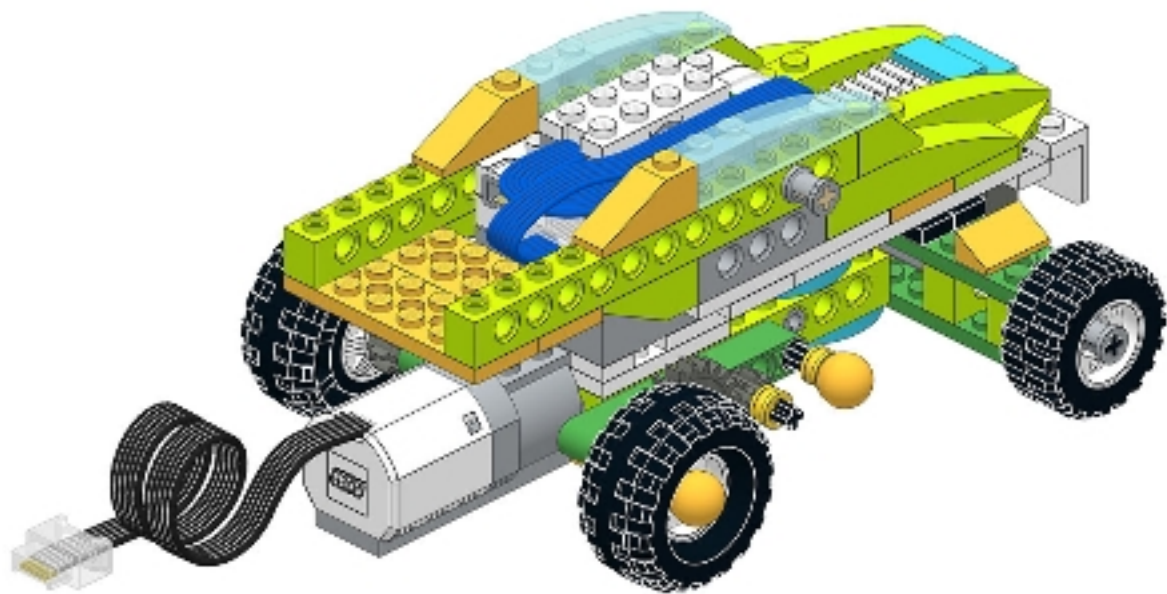

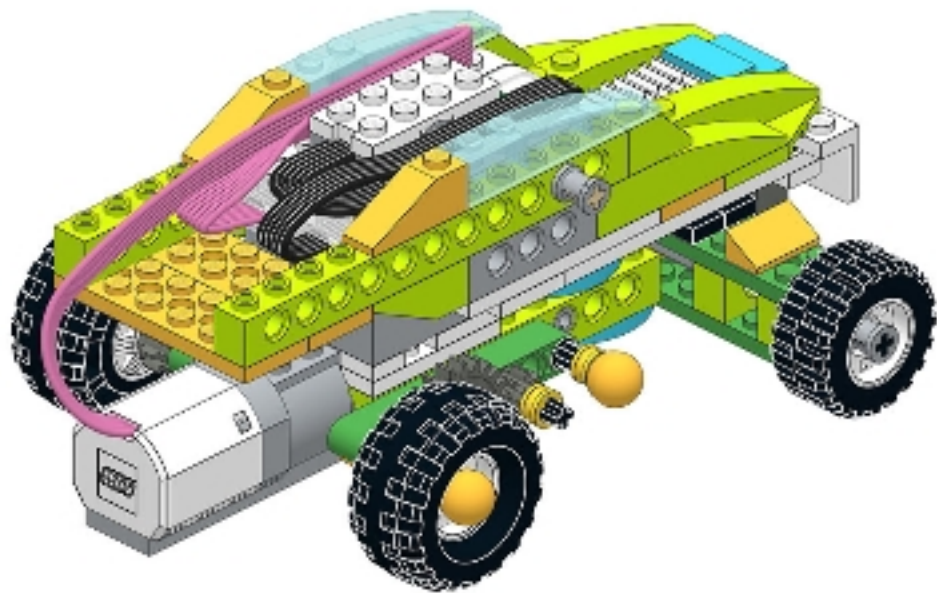



1x

85

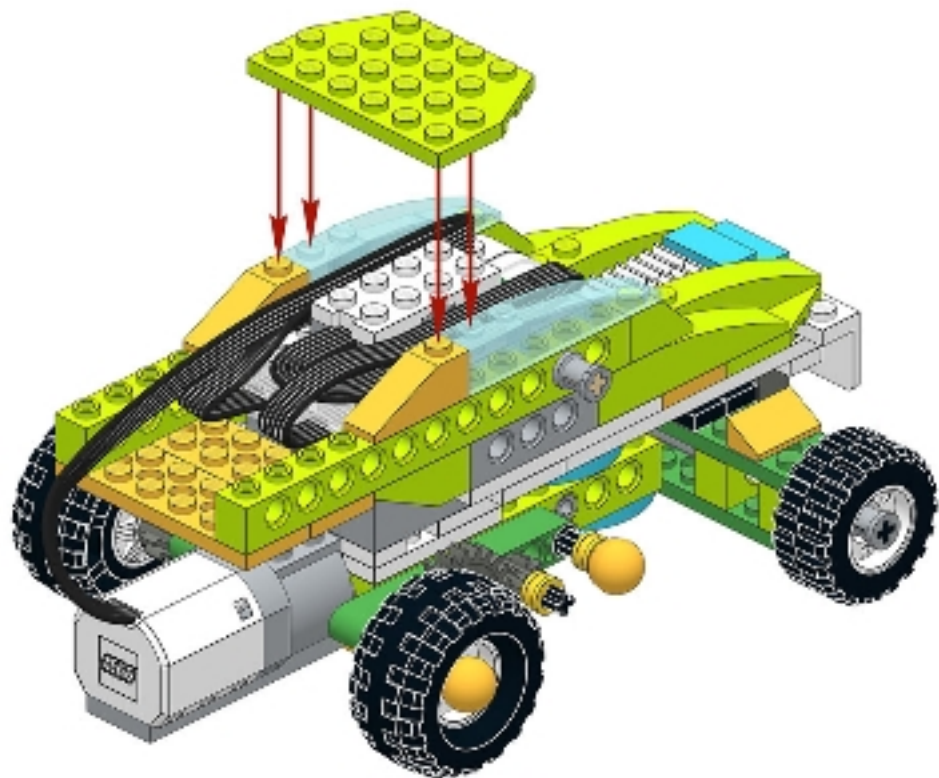

86

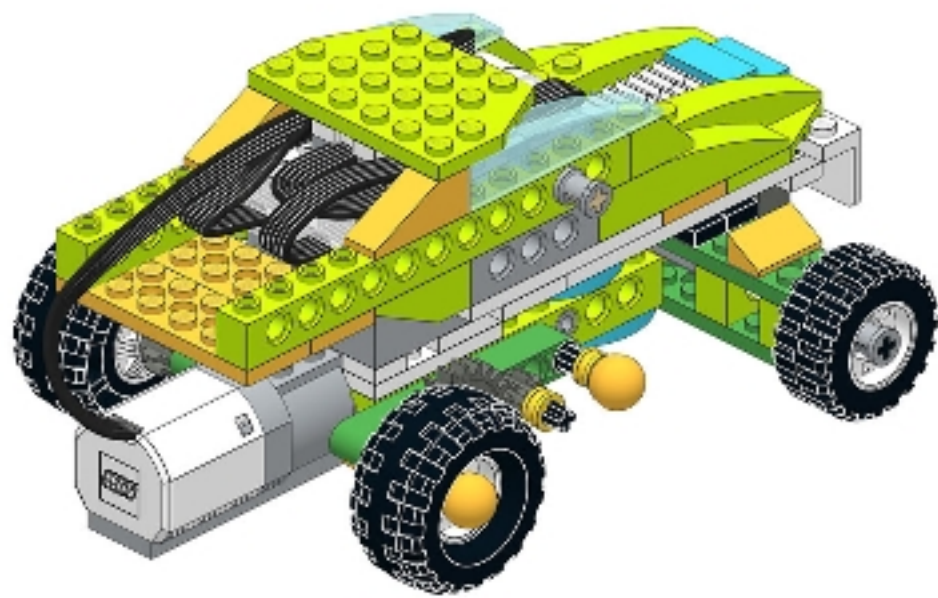



2x

87

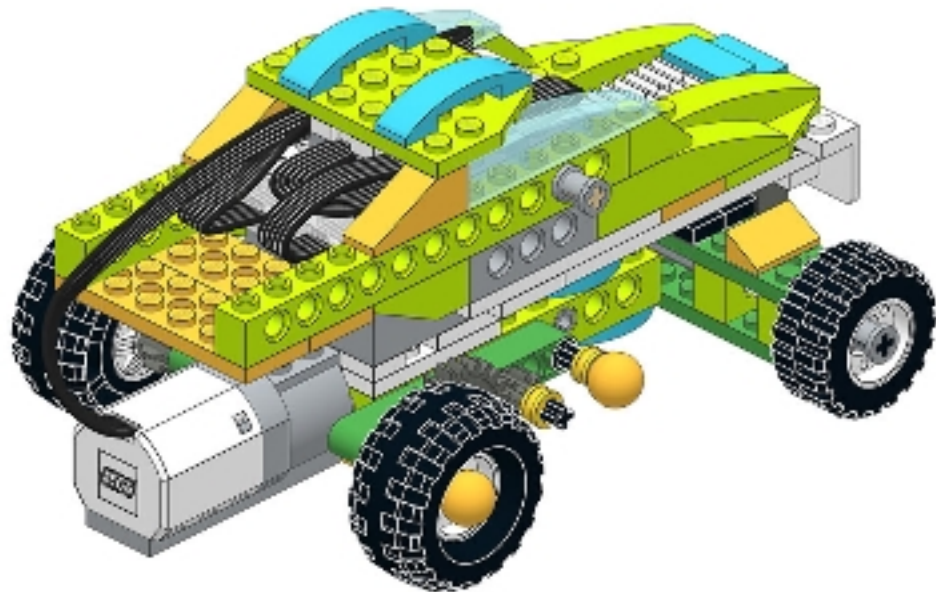



88

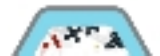
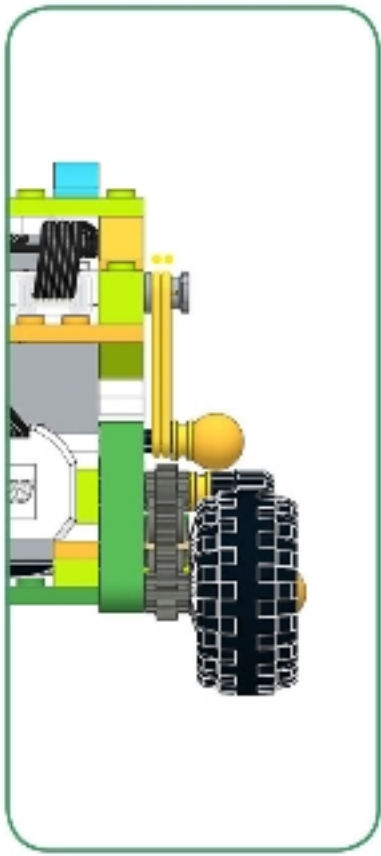
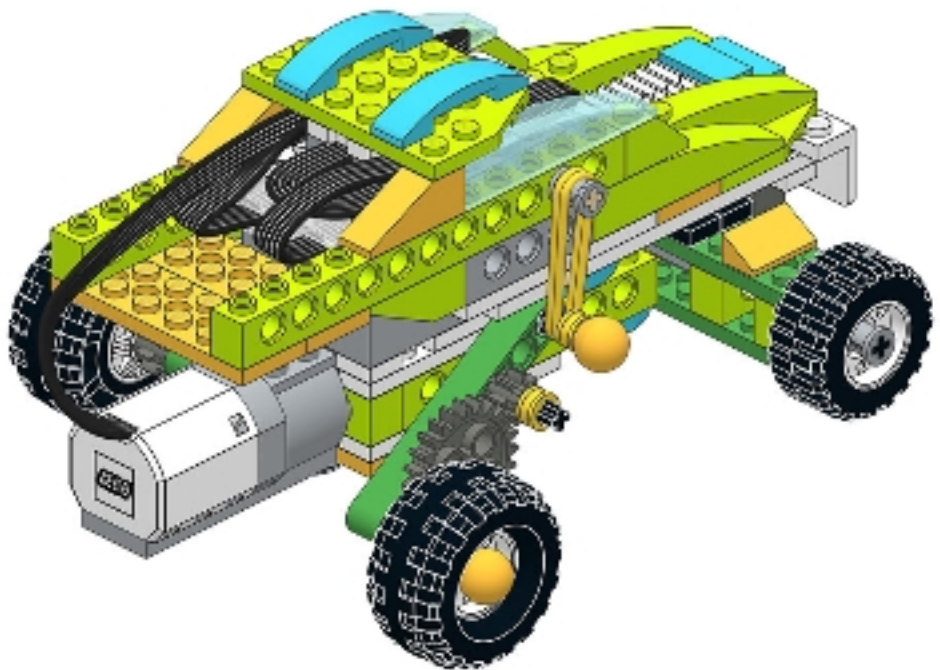

!

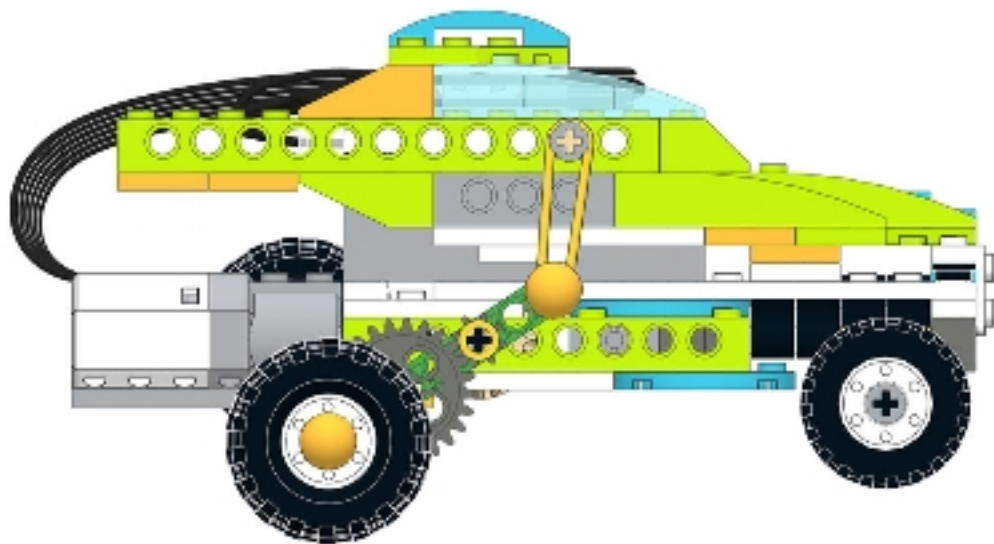



90

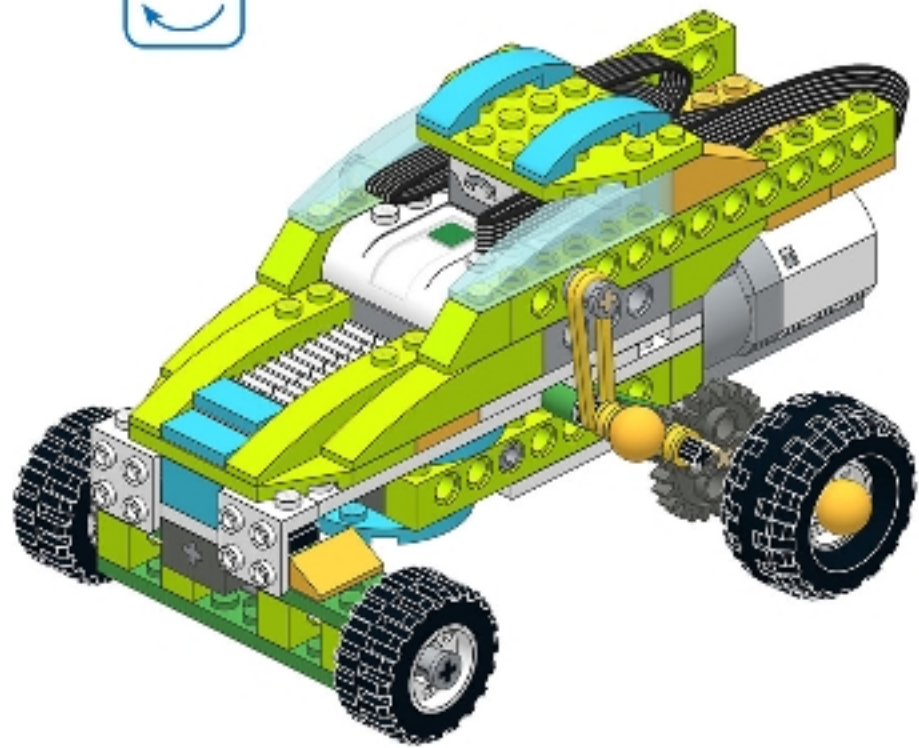

!

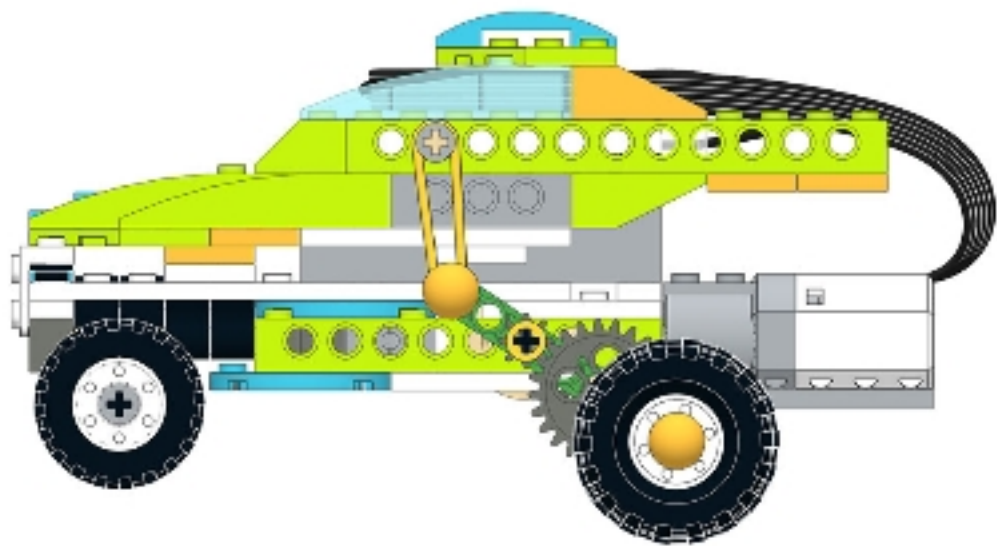



2x

92

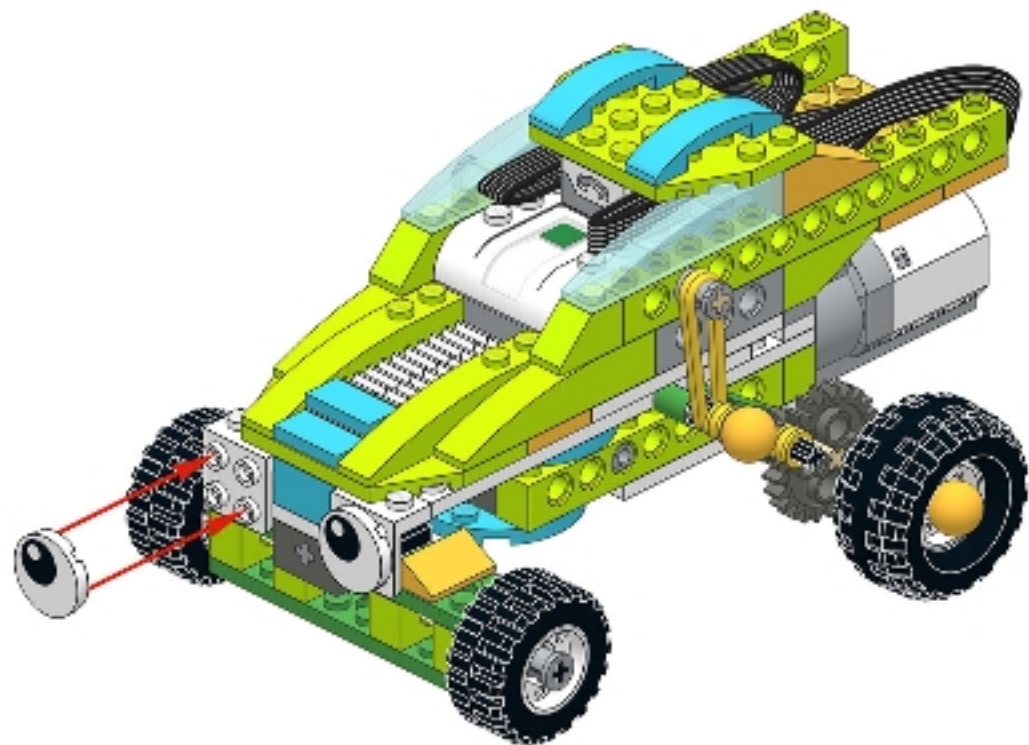

92/93

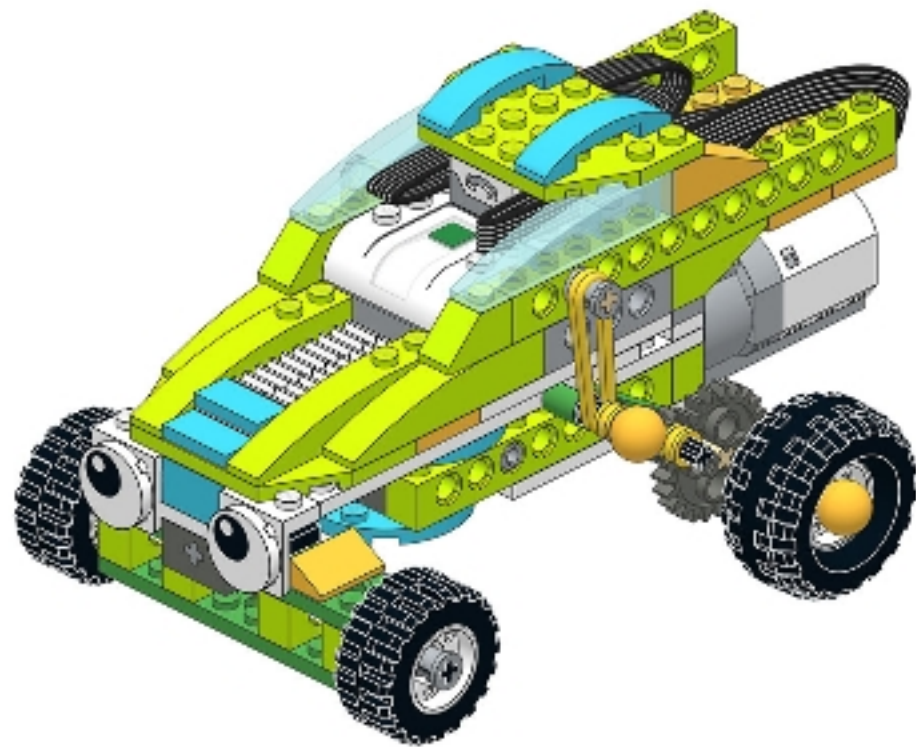



Task 1

Program the robot's stop when any change of sensor value is detected.

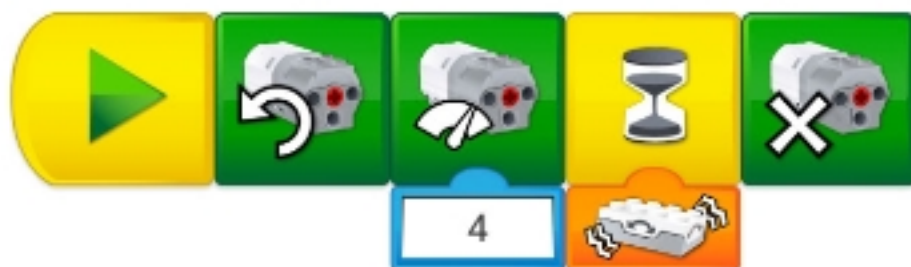



Task 2. Program

Write a robot program for the example below.



This program constantly sends tilt sensor data

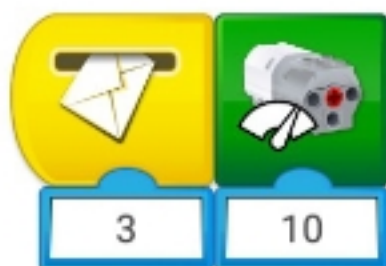
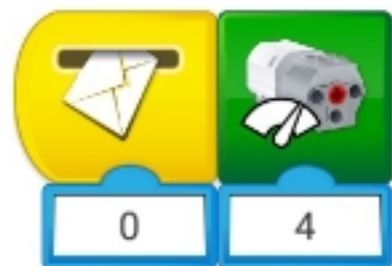

And these three programs receive messages. It works out whose name coincided with the message.



Task 3. Program

Add the programs shown below:



The sound signal pays attention to the fact that there is a danger of the robot's rollover.



Task 3. Questions

What program block repeats to send the datas of tilt sensor?

