

PURCHASED 2018

DAN
CUST SERV. 1-877-356-6663

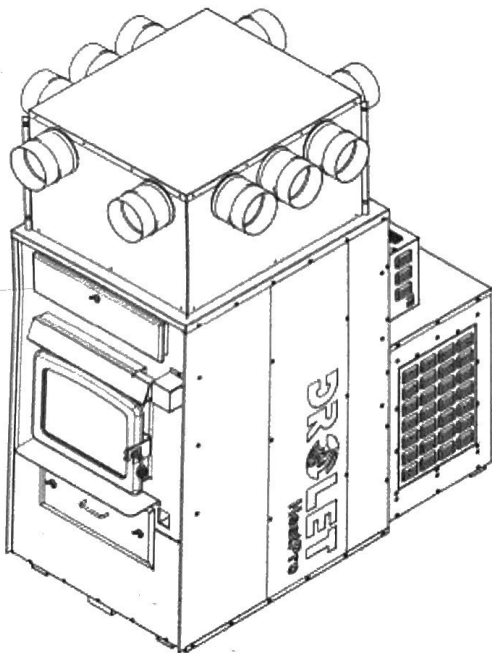

Installation and operating instructions for the **HEATPRO WOOD FURNACE** (DF03000 model)



Verified and tested for Canada
and the United States
by an accredited laboratory

Stove Builder International Inc.
250, rue de Copenhague,
St-Augustin-de-Desmaures (Quebec)
Canada G3A 2H3
After-sale service: 418-908-8002
E-mail: tech@sbi-international.com



This manual is available for free download on the manufacturer's web site. It is a copyrighted document. Re-sale is strictly prohibited. The manufacturer may update this manual from time to time and cannot be responsible for problems, injuries, or damages arising out of the use of information contained in any manual obtained from unauthorized sources.

Please keep this document!

**READ THESE INSTRUCTIONS CAREFULLY BEFORE INSTALLING AND
OPERATING YOUR FURNACE.**

PLEASE KEEP THIS MANUAL FOR REFERENCE

Table of contents

PART 1 – INSTALLATION	6
INTRODUCTION	6
1 Regulations and safety warnings covering installation	7
1.1 Regulations covering furnace installation.....	7
1.2 Cautions and warnings covering installation	7
2 Authorized and non-authorized configuration	8
2.1 Authorized configurations in Canada and United States	8
2.2 Authorized configurations in United States only.....	8
2.3 Non-authorized configuration, Canada and United States	9
3 Setting up the unit and clearances	9
3.1 Unit location	9
3.2 Certification label	9
3.3 Clearances to combustible material	10
3.3.1 Clearances with single and double wall pipe	11
3.3.2 Cold air return ductwork Clearances.....	11
3.3.3 Floor protection.....	12
4 The venting system	13
4.1 The chimney	13
4.1.1 Factory-built metal chimneys	13
4.1.2 Masonry chimneys.....	14
4.1.3 Minimum chimney height	15
4.2 The connector pipe	15
4.2.1 Best practices and requisites of the installation code	15
5 Hot air distribution and air return system	17
5.1 Hot air distribution plenum height according to ceiling height	18
5.1.1 Plenum's minimum height; (only plenum (B) must be used).....	18
5.1.2 Adjustable height of the plenum; (with the plenum extension cut off (A)).	19
5.1.3 Adjustable height of the plenum (A and B); (without cutting) 79" (200 cm) to 88" (224 cm).	19
5.2 Assembling the hot air distribution plenum (A and B).	20
5.2.1 Assembling the plenum extension (A) by means of 12 screws and corner reinforcements	20
5.2.2 Assembling the plenum (B).....	21
5.2.3 Assembling the plenum extension (A) to the plenum (B).....	23
5.3 Installation of the assembled plenum on the furnace	24
5.4 Configuration and restrictions of hot air distribution system	25

5.4.1	Start-off plenum	25
5.4.2	Installing the start-off adapters	26
5.4.3	Minimum amount of outlets and maximum lengths of ducts	26
5.5	Air return system and filter	28
6	Combustion air	29
7	Electrical connection, adjustment of components and calibration of the draw	29
7.1	Raccordement électrique	29
7.2	Installation and connection of the "RTD" thermal probe	31
7.3	Blower technical Data	33
7.4	Draw Calibration	33
7.4.1	The use of a thermometer	34
	Appendix 1: Optional thermostat installation.....	35
	Appendix 2: Optional air filters (AC01390, AC01391)	38
	Appendix 3: Optional Fresh air return adapter (AC01392)	39
	PART 2 –OPERATION, MAINTENANCE AND TROUBLESHOOTING	40
7.5	How to prepare or buy good firewood	40
7.5.1	What is good firewood?	40
7.5.2	Tree species	40
7.5.3	Log length	41
7.5.4	Piece size	41
7.5.5	How to dry firewood	42
7.5.6	Judging firewood moisture content	42
8	Operating your furnace.....	42
8.1	Your first fires.....	43
8.2	Lighting fires.....	43
8.2.1	Conventional fire starting	43
8.2.2	The top down fire	44
8.2.3	Two parallel logs.....	44
8.2.4	Using fire starters.....	44
8.3	Maintaining wood fires	44
8.3.1	General advice.....	45
8.3.2	Raking charcoal.....	45
8.3.3	Firing each new hot load.....	46
8.3.4	Control of the air supply.....	47
8.3.5	Building different fires for different needs	48
8.3.6	Control of the air inlet damper.....	48
8.4	Additional fresh air supply	48

8.5	Manual or thermostat control	49
8.6	Ash drawer.....	50
8.7	Prolonged power outage	50
9	Maintaining your wood heating system.....	51
9.1	Furnace maintenance	51
9.1.1	Ash removal.....	51
9.1.2	Cleaning door glass	51
9.1.3	Door adjustment	52
9.1.4	Replacement of the glass and gaskets	53
9.1.5	Cleaning and painting the furnace	54
9.1.6	Heat exchangers care.....	55
9.2	Chimney and chimney connector maintenance	58
9.2.1	Why chimney cleaning is necessary	58
9.2.2	How often should you clean the chimney?	58
9.2.3	Cleaning the chimney	59
9.3	Smoke pipe inspection.....	59
9.4	Blower motor maintenance	59
10	Troubleshooting	60
10.1	Installation of secondary air tubes and baffle	61
11	Exploded diagram and parts list	63
PART 3 – FEATURES AND SAFETY		66
12	General information on HeatPro (DF03000)	67
12.1	Appliance performance ⁽¹⁾	67
12.2	General Features	68
12.2.1	Technical data HeatPro	69
12.3	The benefits of low emissions and high efficiency	71
12.4	The SBI commitment to you and the environment	71
12.4.1	What is your new furnace made of?	71
13	Safety information.....	72
13.1	Cautions and warnings	72
13.2	Smoke detector.....	74
13.3	Chimney fire.....	74
DROLET LIMITED LIFETIME WARRANTY.....		75

PART 1 – INSTALLATION

Please see **Part 2** for operation, maintenance and troubleshooting instructions.

Please see **Part 3** for features and safety instructions.

INTRODUCTION

This furnace uses the same wood burning technology as a high efficiency certified CSA B415.1. This model meets the emissions limits of CSA B415.1 Standard.

- We recommend that our woodburning hearth products be installed and serviced by professionals who are certified in the United States by NFI (National Fireplace Institute®) or in Canada by WETT (Wood Energy Technical Training) or in Quebec by APC (Association des Professionnels du Chauffage).

BEFORE STARTING THE INSTALLATION, READ ALL THE INSTRUCTIONS BELOW AND MAKE SURE YOU UNDERSTAND THEM. (IF IN DOUBT, CONTACT OUR CUSTOMER SERVICE AT TECH@SBI-INTERNATIONAL.COM). FAILURE TO COMPLY WITH THESE INSTRUCTIONS MAY RESULT IN HAZARD TO YOUR SAFETY AND WILL AUTOMATICALLY VOID THE WARRANTY.

Inspect the furnace to make sure that nothing has been damaged in the shipping. Pull out the tools from the flue pipe and/or exchangers and firebox of the furnace.

IMPORTANT NOTE

FOR, INSTALLATION OF A CENTRAL HEATING VENTILATION SYSTEM, IT IS HIGHLY RECOMMENDED TO CONSULT A HEATING SYSTEM VENTILATION SPECIALIST.

N.B.: STOVE BUILDER INTERNATIONAL INC. IS NOT RESPONSIBLE FOR POOR APPLIANCE PERFORMANCES, DUE TO IMPROPER INSTALLATION OF EXHAUST SYSTEM OR DUCTING.

1 Regulations and safety warnings covering installation

1.1 Regulations covering furnace installation

CAUTION
FOLLOW LOCAL CODES (IF IN DOUBT, CONTACT YOUR LOCAL HEATING APPLIANCE RETAILER, YOUR MUNICIPALITY OR YOUR FIRE DEPARTMENT)

Installation must be made in accordance with the following standards;

Canada: CSA-B365 - Installation code for solid-fuel-burning appliances and equipment.
CSA C22.1 - Canadian electrical code.

United-States: NFPA 90B - Standard for the installation of warm air heating and air-conditioning systems. NFPA 70 - National Electrical Code.

1.2 Cautions and warnings covering installation

- THE INFORMATION GIVEN ON THE CERTIFICATION LABEL AFFIXED TO THE APPLIANCE ALWAYS OVERRIDES THE INFORMATION PUBLISHED, IN ANY OTHER MEDIA (OWNER'S MANUAL, CATALOGUES, FLYERS, MAGAZINES AND/OR WEB SITES).
- AIR DUCTS SERVING A GARAGE SHOULD NOT BE CONNECTED TO OTHER PARTS OF A HOUSE AND THE DUCTING SERVING A HOUSE SHOULD NOT BE CONNECTED TO A GARAGE.
- MIXING OF CHIMNEY COMPONENTS FROM DIFFERENT SOURCES OR MODIFYING FURNACE COMPONENTS MAY RESULT IN HAZARDOUS CONDITIONS. WHERE ANY SUCH CHANGES ARE PLANNED, FURNACE BUILDER INTERNATIONAL INC. SHOULD BE CONTACTED IN ADVANCE.
- ANY MODIFICATION OF THE APPLIANCE THAT HAS NOT BEEN APPROVED IN WRITING BY THE TESTING AUTHORITY VIOLATES CSA B365 (CANADA), AND NFPA 90B (USA).
- CONNECT THIS FURNACE ONLY TO A LISTED UL 103 HT OR ULC S629 FACTORY-BUILT CHIMNEY FOR USE WITH SOLID FUEL OR TO A LINED MASONRY CHIMNEY CONFORMING TO NATIONAL AND LOCAL BUILDING CODES.
- IF REQUIRED, A SUPPLY OF COMBUSTION AIR SHALL BE PROVIDED TO THE ROOM OR SPACE.
- DO NOT STORE NEAR WOOD FURNACE. RESPECT THE PRESCRIBED CLEARANCE BETWEEN COMBUSTIBLES AND HEAT.
- DO NOT CONNECT THIS UNIT TO A CHIMNEY FLUE SERVING ANOTHER APPLIANCE.
- DO NOT INSTALL IN A MOBILE HOME
- DO NOT INSTALL IN ALCOVE

2 Authorized and non-authorized configuration

2.1 Authorized configurations in Canada and United States

The wood furnace is the only appliance connected to the hot air distribution duct system and air return duct system.

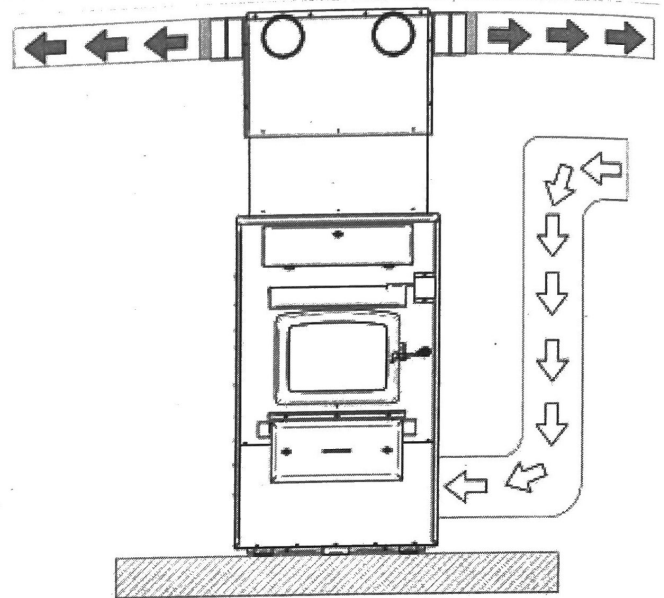

2.2 Authorized configurations in United States only

Parallel installation :

- (A) represents the wood furnace.
- (B) represents the gas, oil or electric existing furnace.
- Power input (B) should be equal to or greater than (A).
- Each furnace must have its own air return duct system.
- The highest clearances of (A and B) and hot air distribution and air return ducts of must be respected.
- Static pressure of (A) must be adjusted to 0.20 in. W.C. (50 Pa).

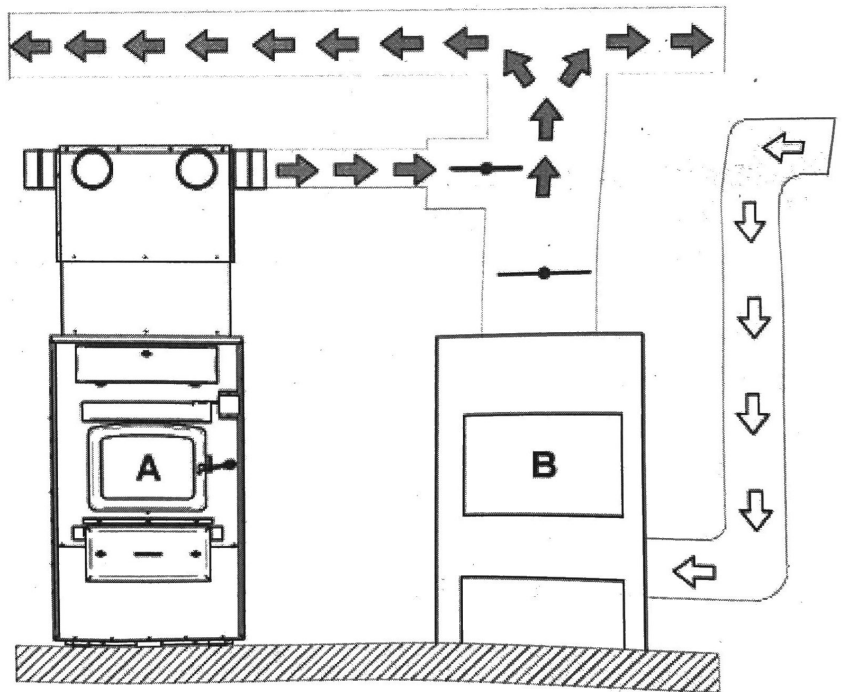

2.3 Non-authorized configuration, Canada and United States

- The hot air duct (A) must not be installed in the air return of (B).
- The hot air duct (B) must not be installed in the air return of (A).

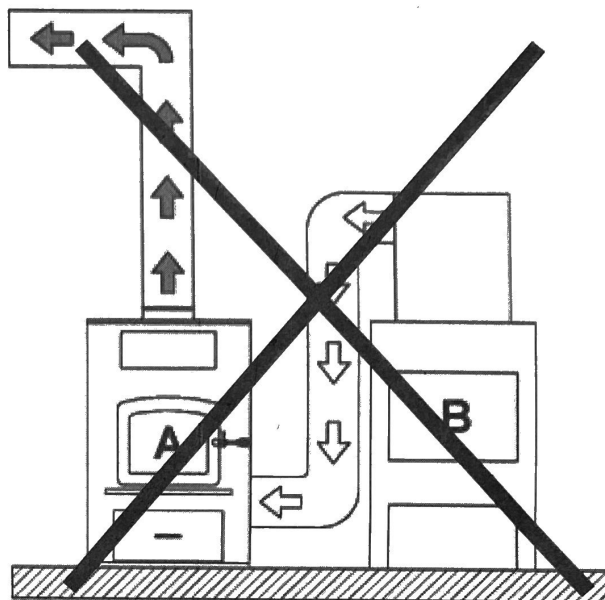

3 Setting up the unit and clearances

To reduce the risk of vibration, the furnace must be leveled in both directions and supported evenly to ensure stability.

3.1 Unit location

The furnace must be installed in a location:

- Where outside air supply will be sufficient for proper combustion.
- Where connector is as short as possible in order to minimize the use of 90° elbows and horizontal lengths;
- That ensure a proper installation and safe operation of the appliance;
- Where the owner can ensure cleanliness of the room in the event of negative pressure or temporarily negative.
- Where room to perform maintenance is sufficient and safe.

3.2 Certification label

N.B.: THIS APPLIANCE MUST BE INSTALLED IN ACCORDANCE WITH THE INSTRUCTIONS ON THE CERTIFICATION LABEL APPLIED ON THE UNIT.

Location: You will find the certification label on the back of the appliance.

Information found on the certification label always overrides the information published in any other publication.

Content of certification label: Model number, serial number, certification agency, Standards, clearances to combustible material, as well as the main safety cautions.

3.3 Clearances to combustible material

The clearances shown in this section have been determined by safety tests under normal and even abnormal operating conditions according to procedures set out in standards CSA B366.1 (Canada) and UL 391 (U.S.A.). Respecting the minimum clearances is mandatory to prevent risk of fire.

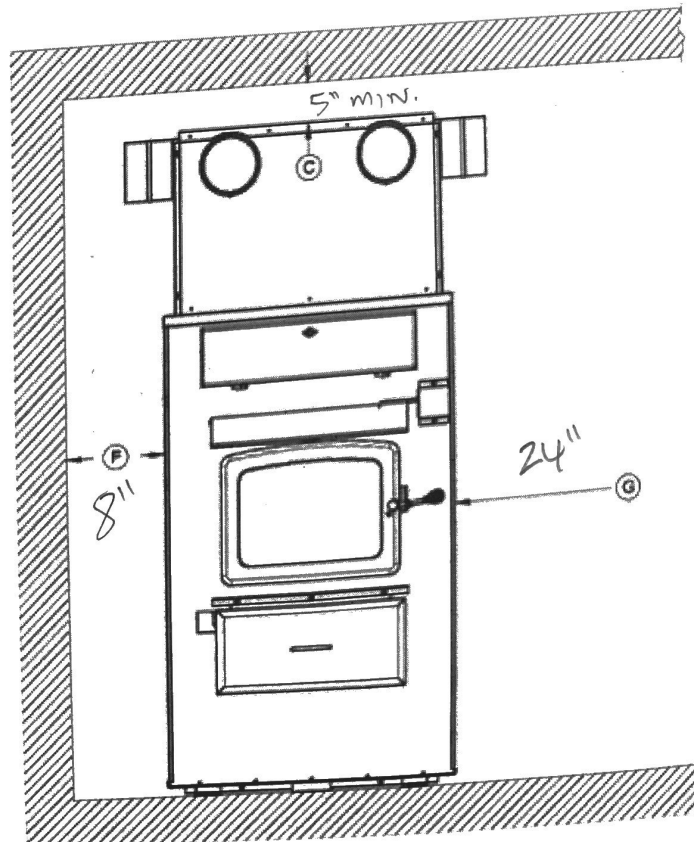
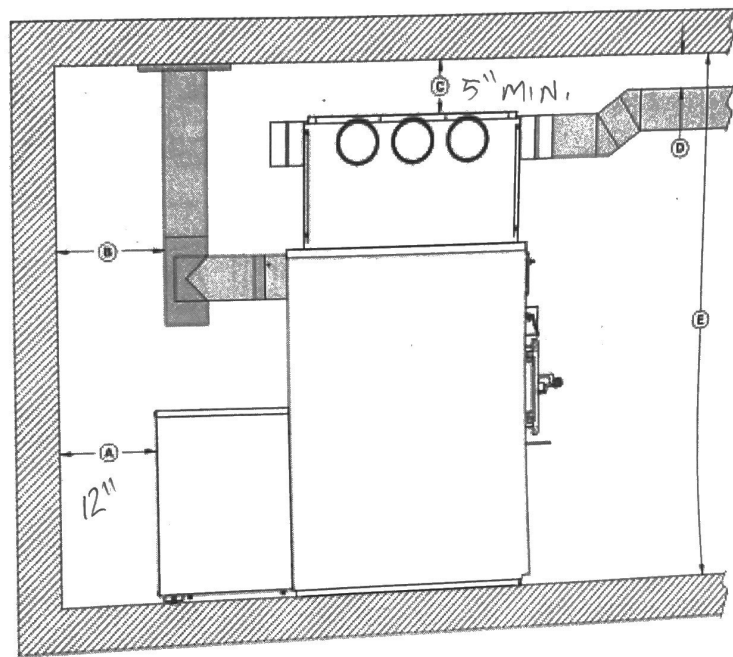

3.3.1 Clearances with single and double wall pipe

	CANADA	USA
A	12" (305 mm)	12" (305 mm)
B	18" (457 mm)	18" (457 mm)
C	5" (127 mm)	5" (127 mm)
D	1" (25 mm)	1" (25 mm)
E	72" (183 cm) minimum	72" (183 cm) minimum
F	8" (203 mm)	8" (203 mm)
G*	24" (610 mm)	24" (610 mm)

*Required for maintenance or replacement of components, however a 30" (762 mm) clearance is suggested.

3.3.2 Cold air return ductwork Clearances

The cold air return system can be connected to a new or to an existing cold air return ductwork. In both cases, the minimum clearance to combustible material is 0" (0 mm).

WE DO NOT HAVE THIS CURRENTLY, IT WOULD BE BEST IF WE DREW COLD AIR FROM 2ND OR THIRD FLOOR.

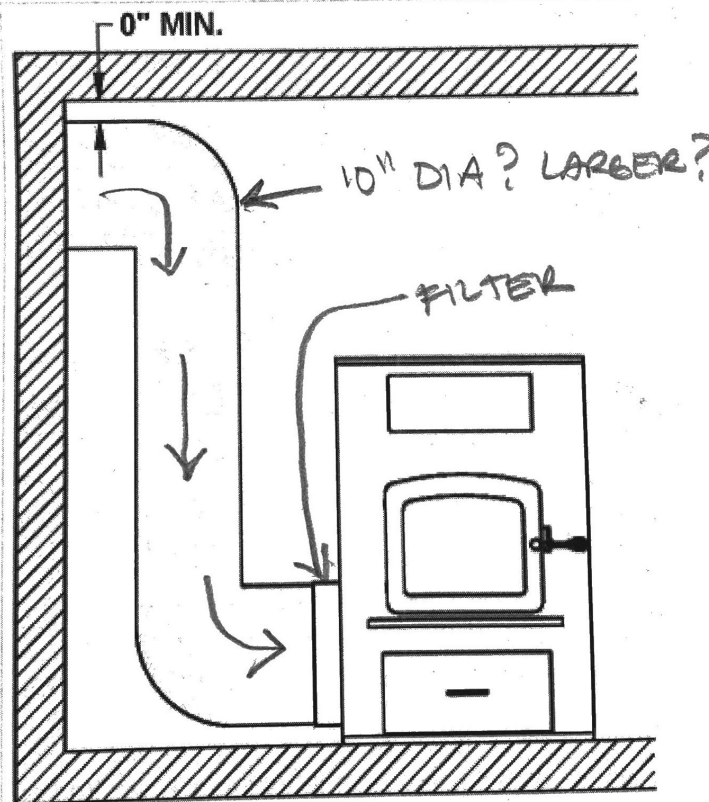

3.3.3 Floor protection

- If the floor is made of non combustible material, no floor protector is required.
- If the floor is made of combustible material, a floor protector is required (see table below).

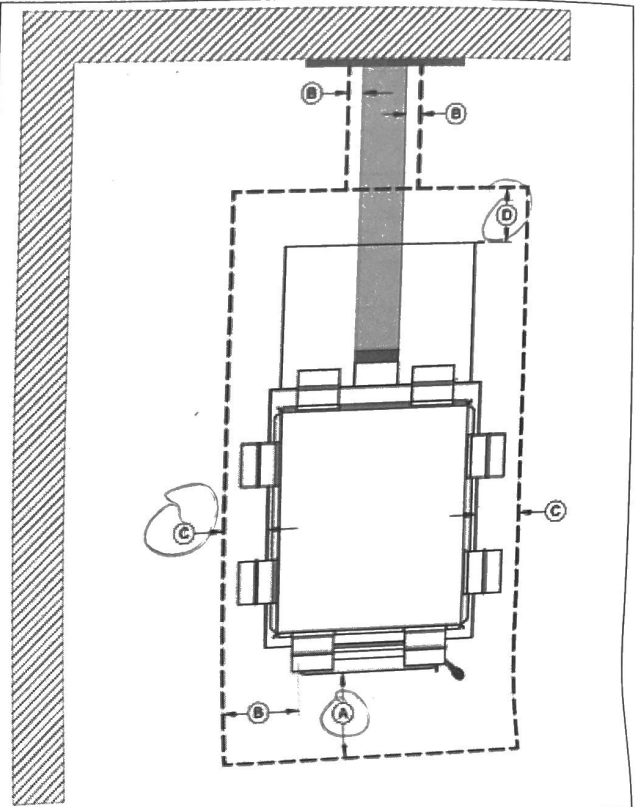

FLOOR PROTECTION*		
	CANADA	USA
A	18" (457 mm) From door opening	16" (406 mm) From door opening
B	N/A (É-U. seulement)	8" (203 mm) From door opening
C	8" (203 mm)	N/A (Canada only)
D	8" (203 mm) – Note 1	N/A (Canada only)
E	N/A (É-U. only)	Note 2

*Steel with a minimum thickness of 0.015" (0.38 mm) or ceramic tiles sealed together with grout. No protection is required if the unit is installed on a non-combustible floor (ex: concrete).

Note 1: The floor protection at the back of the furnace is limited to the furnace's required clearance (A) if such clearance is smaller than 8" (203 mm).

Note 2: Only required under the horizontal section of the connector. Must exceed each side of the connector pipe by at least 2" (51 mm).

4 The venting system

WARNING:
DO NOT INSTALL A MANUAL DAMPER ON THIS FURNACE.

CAUTION: BEFORE THE CONNECTOR PIPES ARE INSTALLED, MAKE SURE THAT THE EXHAUST PIPE AND / OR THE EXCHANGERS OF THE FURNACE ARE FREE OF ALL ITEMS.

4.1 The chimney

- The furnace must be connected to a factory-built metal chimney that complies with UL 103 HT (USA) or ULC S629 (Canada).
 - o Strongly recommended inner diameter: 6" (152 mm).
 - o A chimney having a diameter of more than 7" (178 mm) is permitted, if it allows the proper venting of combustion gases and that such application is verified and authorized by a qualified installer. Otherwise, the diameter of the flue must be reduced to 6" (152 mm) by the use of a stainless steel liner made for this purpose.

4.1.1 Factory-built metal chimneys

To be suitable, a factory-built metal chimney also called "high temp" chimney, must comply with UL 103 HT (U.S.A.) or ULC S629 (Canada).

- Use only components intended for the brand and model of chimney you are using.
- Never substitute parts from other chimney brands.
- Never fabricate your own components.
- The chimney must be a type suitable for solid fuel.
- To be safe and effective, the chimney must be installed exactly in accordance with the manufacturer's instructions.

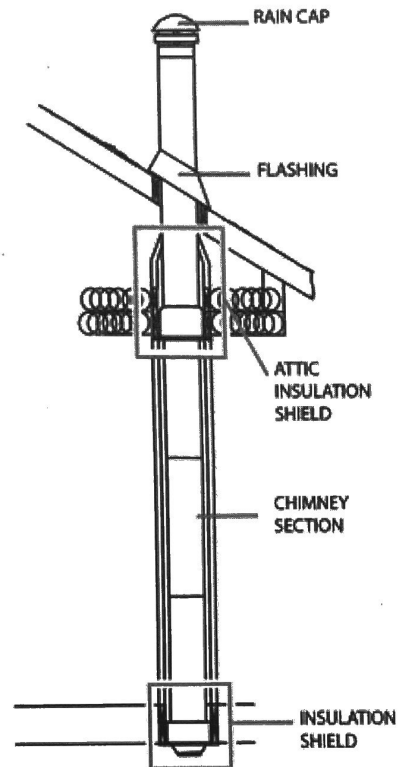



Good system design

Inside chimneys are preferred because even when no fire is burning, there is normally upward flow in the system.

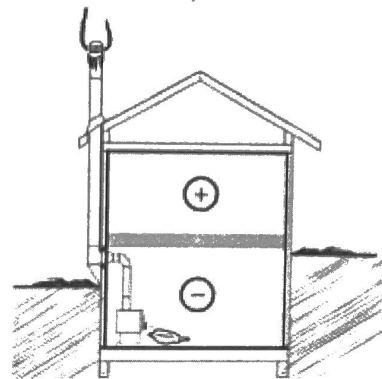

Inferior system design

Outside chimneys are a problem because when no fire burns they will go into cold backdraft if the furnace is installed low in the house.

4.1.2 Masonry chimneys

The furnace may also be connected to a masonry chimney, provided the chimney complies with the construction rules found in the building code enforced locally.

- The chimney must have a clay liner.
- If the masonry chimney has a square or rectangular liner that is larger in cross sectional area than a round 6" (152 mm) flue, it should be relined with a suitably listed 6" (152 mm) stainless steel liner.
- When passing through a combustible wall, the use of an insulated listed thimble is required.
- If a stainless steel jacket (liner) is to be installed, it must extend 12" (305 mm) to 18" (457 mm) above the top of the masonry chimney to favor the draw.

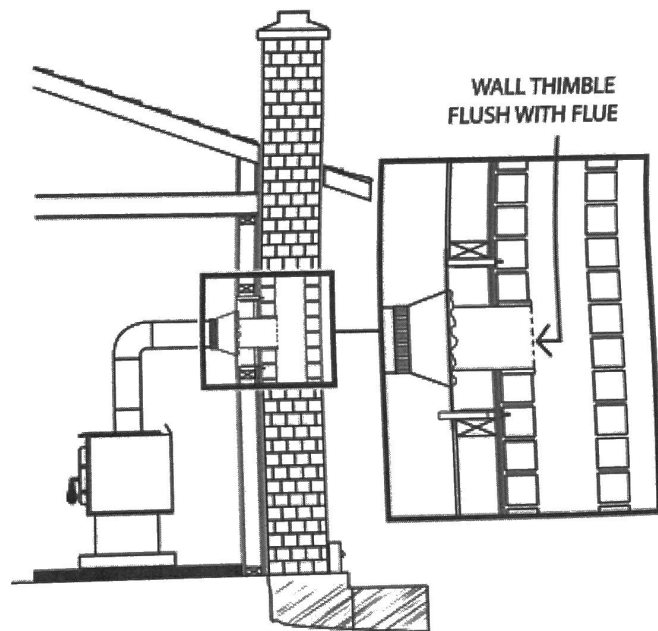

4.1.3 Minimum chimney height

The top of the chimney should be tall enough to be above the air turbulence caused when wind blows against the house and its roof.

- The chimney must extend at least 3 ft. (1 m) above the highest point of contact with the roof.
- Extend at least 2 ft. (61 cm) higher than any roof line or obstacle within a horizontal distance of 10 ft. (3 m).

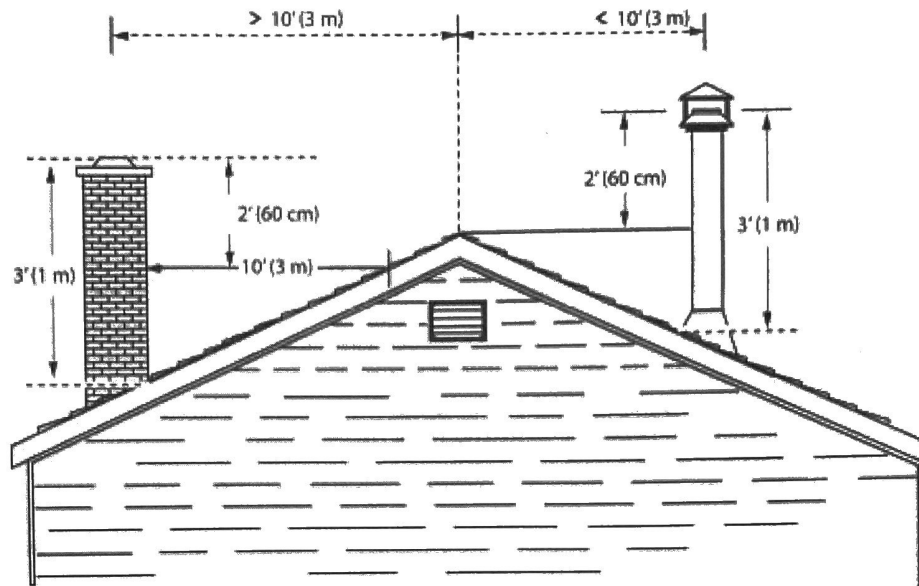

4.2 The connector pipe

- o Recommended inner diameter: 6" (152 mm)
- If an increaser/reducer must be used (max 6" (152 mm) to 7" (178 mm)), it must be installed as close as possible to the chimney.

4.2.1 Best practices and requisites of the installation code

- o Where passage through a wall or partition of combustible construction is desired, the installation shall conform to CAN/CSA-B365, Installation Code for Solid-Fuel-Burning Appliances and Equipment;
- o A flue pipe must never pass through a combustible floor or ceiling or through an attic, roof space, closet or concealed space.
- o Minimum upward slope towards the chimney: 1/4 in/ft. (20 mm/m);
- o The maximum horizontal run is 10' (3 m). Do not count the starting elbow;

- All flue pipe joints must be secured with three screws. Failure to secure them to each other may cause a fire;

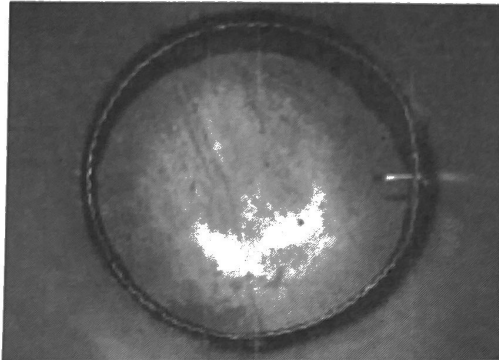

Proper installation

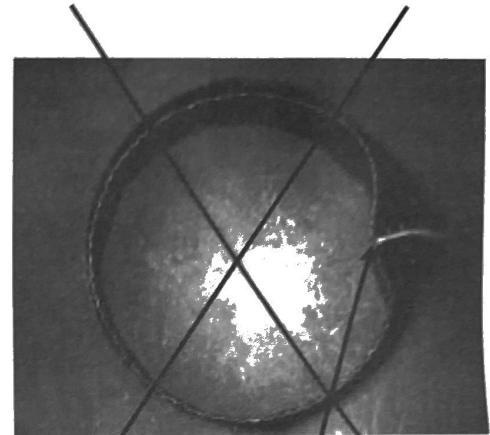

**CAUSES
RESTRICTION**

improper installation

- Maximum unsupported horizontal length: 3 feet (1 m);
- Galvanized flue pipes must not be used because the coatings vaporize at high temperatures and release dangerous gases;
- Flue pipes must be at least 24 gauge in thickness;
- The chimney connector must be in good condition;
- Flue pipe joints should overlap 1 1/4". (30 mm);
- Straight up installations needs to have either a connector where one end has no fastener or a telescopic length;
- Removal of the assembly for cleaning should not require that the furnace be moved;
- The male ends of the sections must be oriented towards the appliance so that falling dust and condensation stay inside the pipe;
- A straight flue pipe assembly offers the least restriction to gas flow and results in stronger draft. Straight assemblies also need less maintenance because there are no corners to collect creosote;
- The use of 45° elbows is strongly recommended;
- A 90° elbow = 5' (152 cm), a 45° elbow = 2.5' (76 cm);
- Never use more than two 90° elbows;

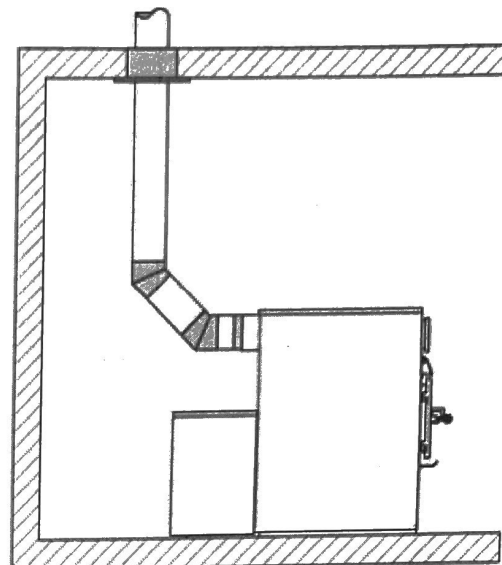
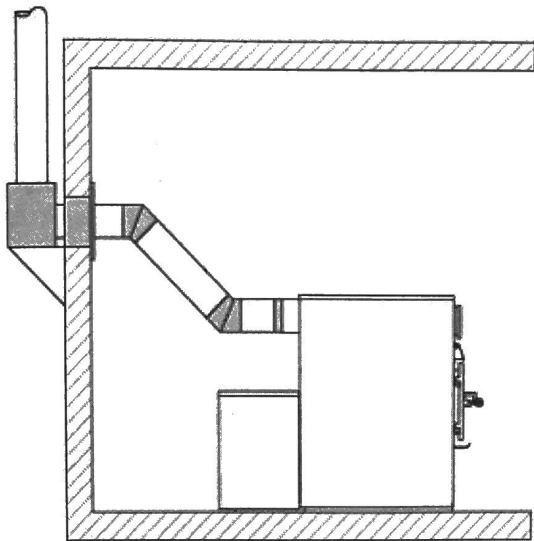

Use 45° elbows where possible, rather than 90° elbows.

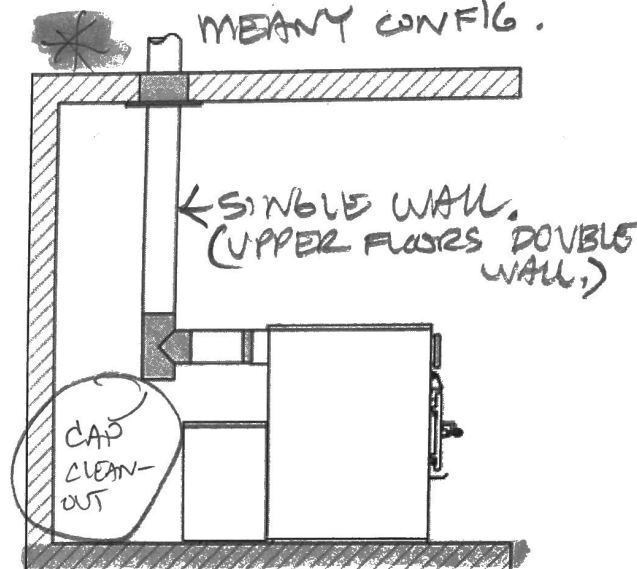
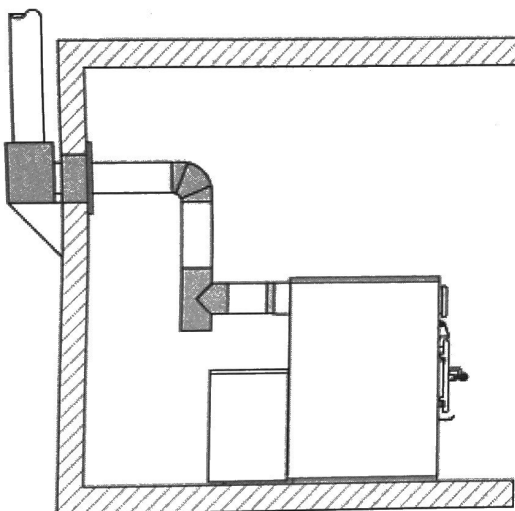

* NON CLOSING
6 MIN. DUCTS Alternative installations with 90° elbow or tee.



5 Hot air distribution and air return system

The Drolet furnace is designed and equipped with a hot air distribution plenum that may receive 6 to 10, 6" (152 mm) diameter round ducts.

The installer is responsible of the performance of the distribution ducts and the air return system. It will have a direct effect on the ability of the blower to distribute heat efficiently throughout the house. The number, size and length of the ducts of the distribution system and return air will vary depending on the configuration and characteristics of each house.

N.B.: The furnace air jacket is not totally air tight. It is normal to detect some air leaks at the jacket's joints.

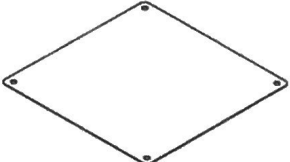
Components provided with the furnace:

			
<p>10 hot air start-off adapter (A)</p>	<p>4 lids (B)</p>	<p>Type A #10 black screws (C)</p>	<p>#10 self-taping black screws (D)</p>

5.1 Hot air distribution plenum height according to ceiling height

Remember to take into account the 5" (127 mm) clearance to combustibles above the plenum.

5.1.1 Plenum's minimum height; (only plenum (B) must be used)

For a minimum ceiling height of 72" (183 cm).

MEANY CONFIGURATION

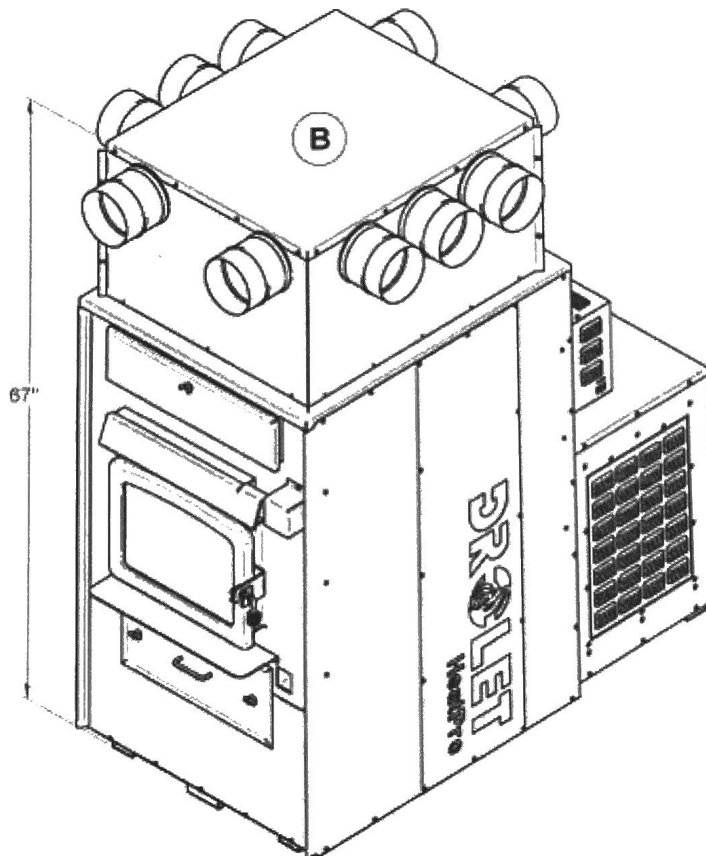

5.1.2 Adjustable height of the plenum; (with the plenum extension cut off (A)).

When the ceiling height, measured from the floor is greater than 72" (183 cm), but less than 84" (213 cm), it will be possible to cut the plenum extension (A) of at most 10" (254 mm). The plenum extension (A) must therefore have a minimum height of 14" (356 mm).

Warning: The plenum extension (A) should not obstruct the openings for the hot air distribution of the plenum (B). The shaded area represents the **maximum** cutting of plenum extension (A).

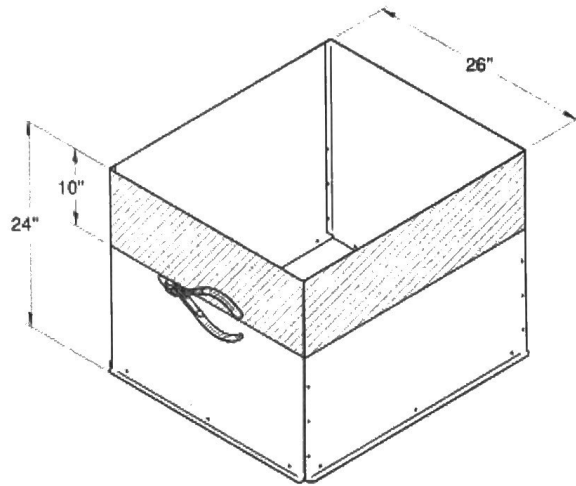

5.1.3 Adjustable height of the plenum (A and B); (without cutting) 79" (200 cm) to 88" (224 cm).

For ceiling height greater than 84" (213 cm).

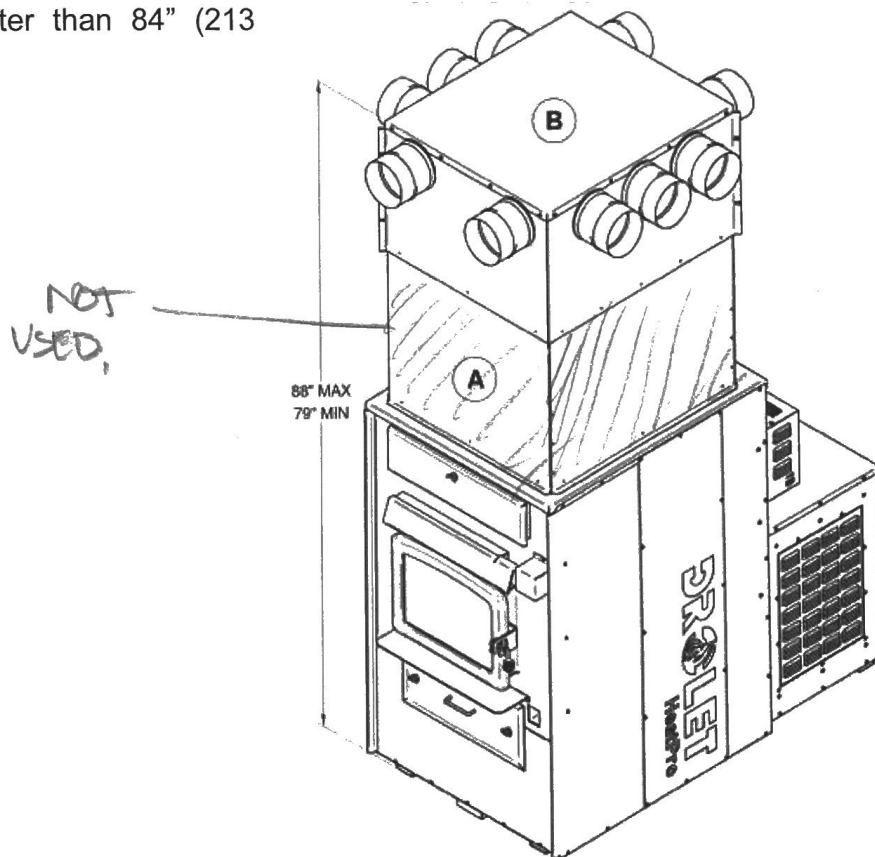

5.2 Assembling the hot air distribution plenum (A and B).

5.2.1 Assembling the plenum extension (A) by means of 12 screws and corner reinforcements

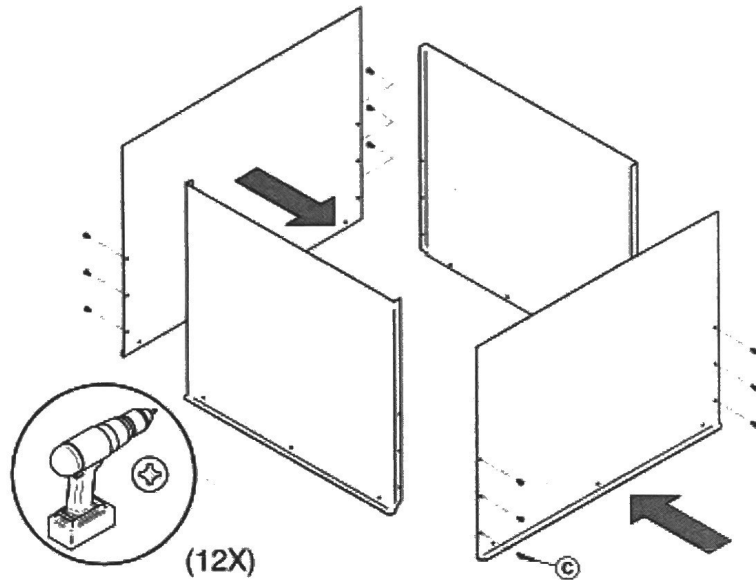

EXTENDER BOX.
NOT USED.

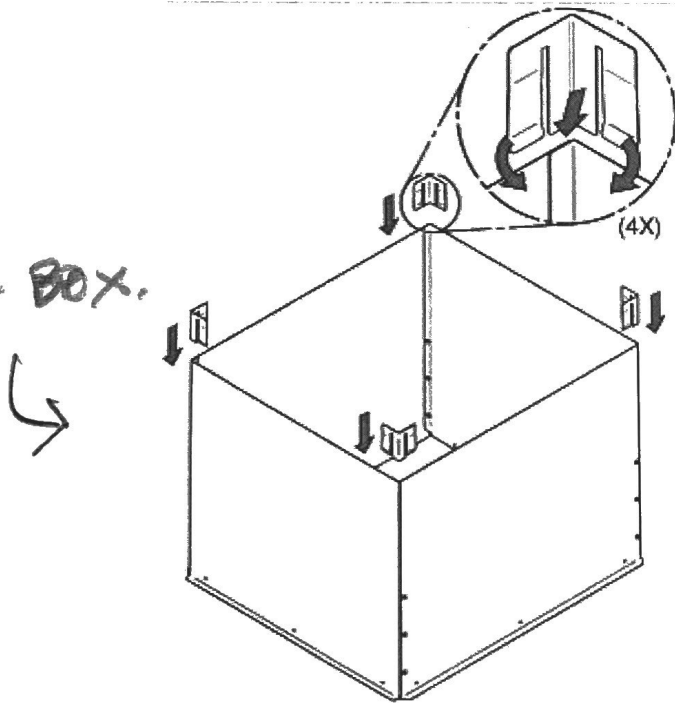

5.2.2 Assembling the plenum (B)

Insert the male end of each panel in the female part of the adjacent panel.

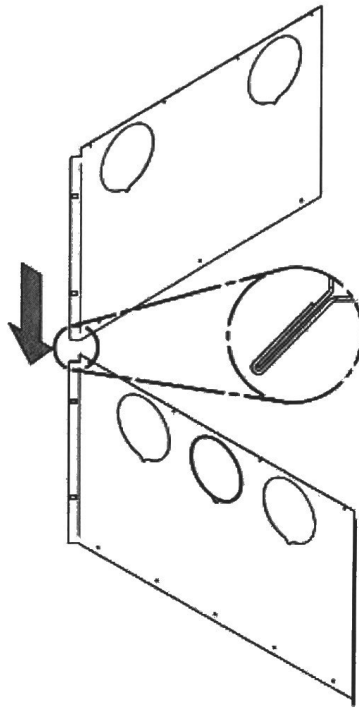

Secure the assembly by bending the two metal tabs in the center of each corner.

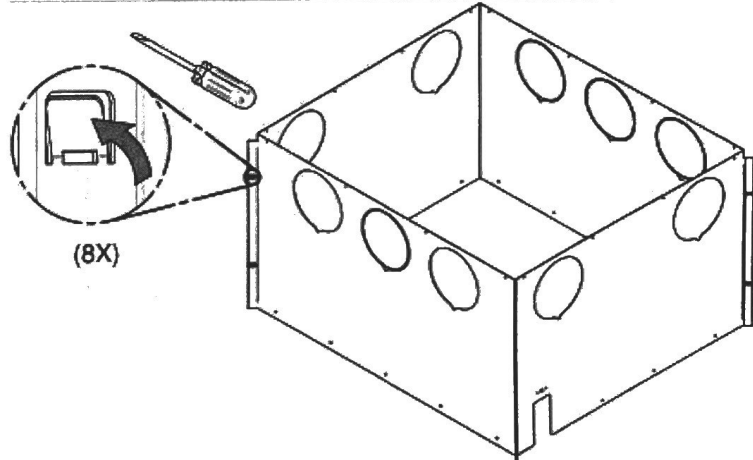

Install the cover on the part (B) of the assembly and secure it with 16 screws.

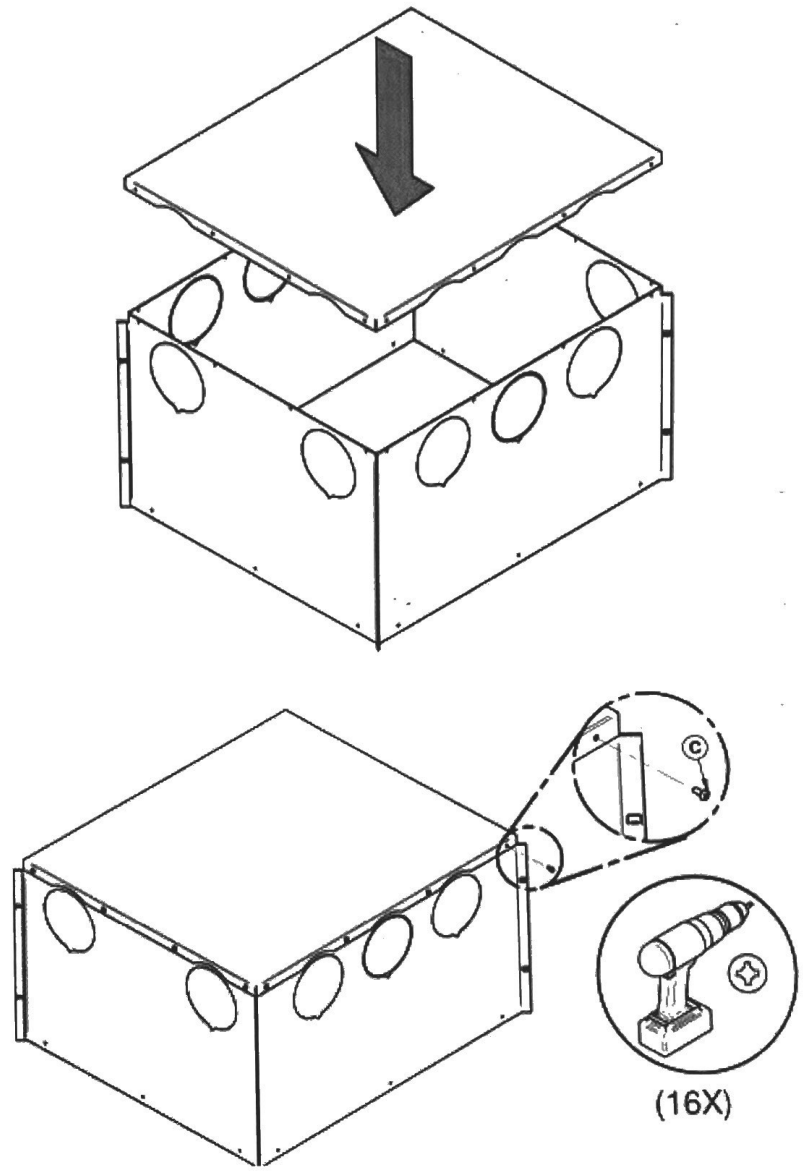

WE DO NOT USE THIS EXTENDER.

5.2.3 Assembling the plenum extension (A) to the plenum (B)

Slide plenum (B) over the plenum extension (A) to the extent determined in Section 11.1.

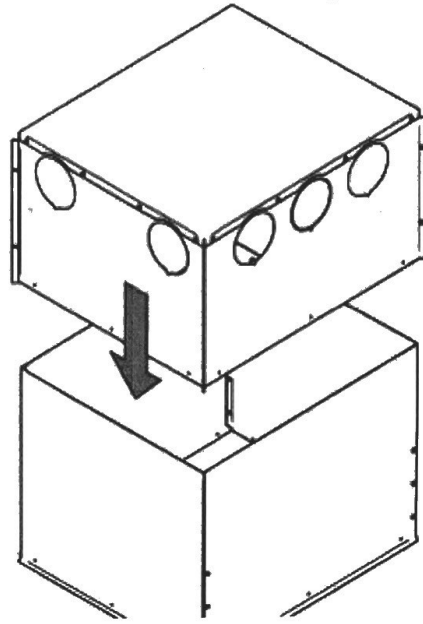

Using 12 self-drilling screws, secure the plenum (B) to the plenum extension (A).

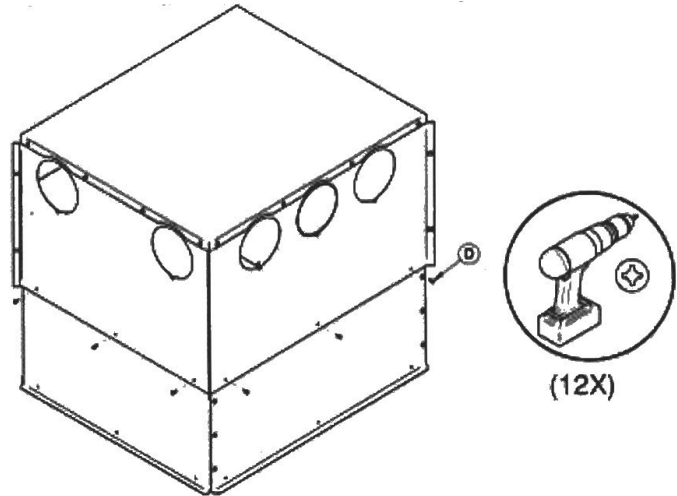

5.3 Installation of the assembled plenum on the furnace

Identify the rear side of the plenum, it is provided with holes for the installation of the "RTD" thermal probe.

Also, four holes are aligned with the fold of the top of the furnace at the rear side and three holes on the front side. This allows you to secure the plenum properly.

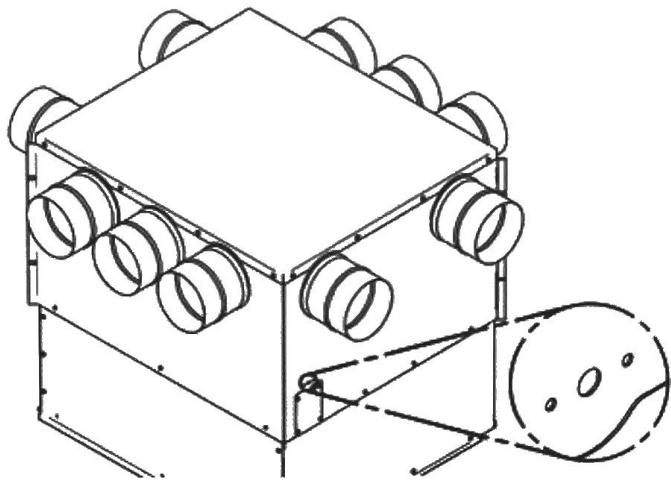

Install the assembly on the furnace, taking care to insert the 4 fold on top of the furnace **inside** the plenum.

*WE DO NOT
USE THIS EXTENDER
PIECE.*

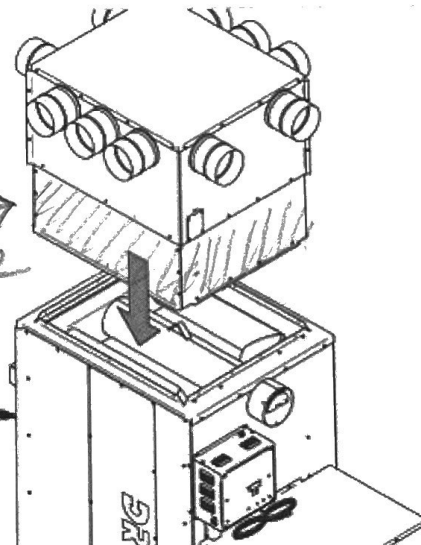

Using 13 screws, secure the plenum to the furnace.

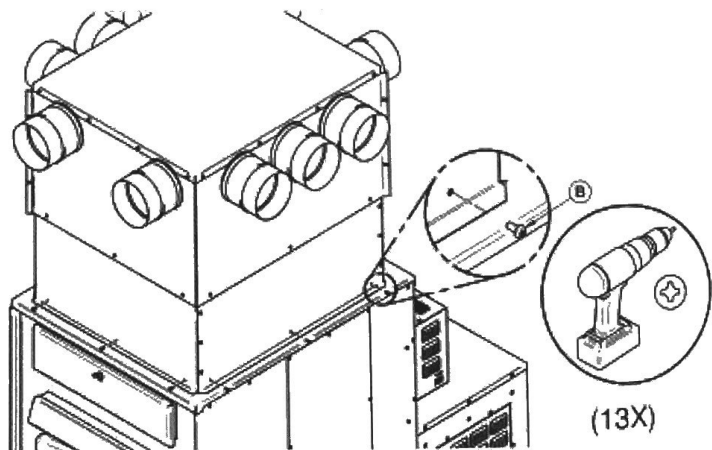

5.4 Configuration and restrictions of hot air distribution system

5.4.1 Start-off plenum

- The plenum can be adjusted from 67" (170 cm) to 88" (224 cm) depending on ceiling height. See **Section 11.1: Hot air distribution plenum height according to ceiling height.**
- The start-off plenum must have a minimum height of 18" (457 mm) from the top of the furnace (**X**). In this case, use only the upper section of the plenum (the one with the 10 openings).
- The minimum clearance (**C**) between the top of the plenum and the ceiling is 5" (127 mm).
- The ducts minimum clearance (**D**) to combustible materials is 1" (25 mm).
- The ducts may pass through a combustible wall maintaining a clearance of 1" (25 mm) around ducts.

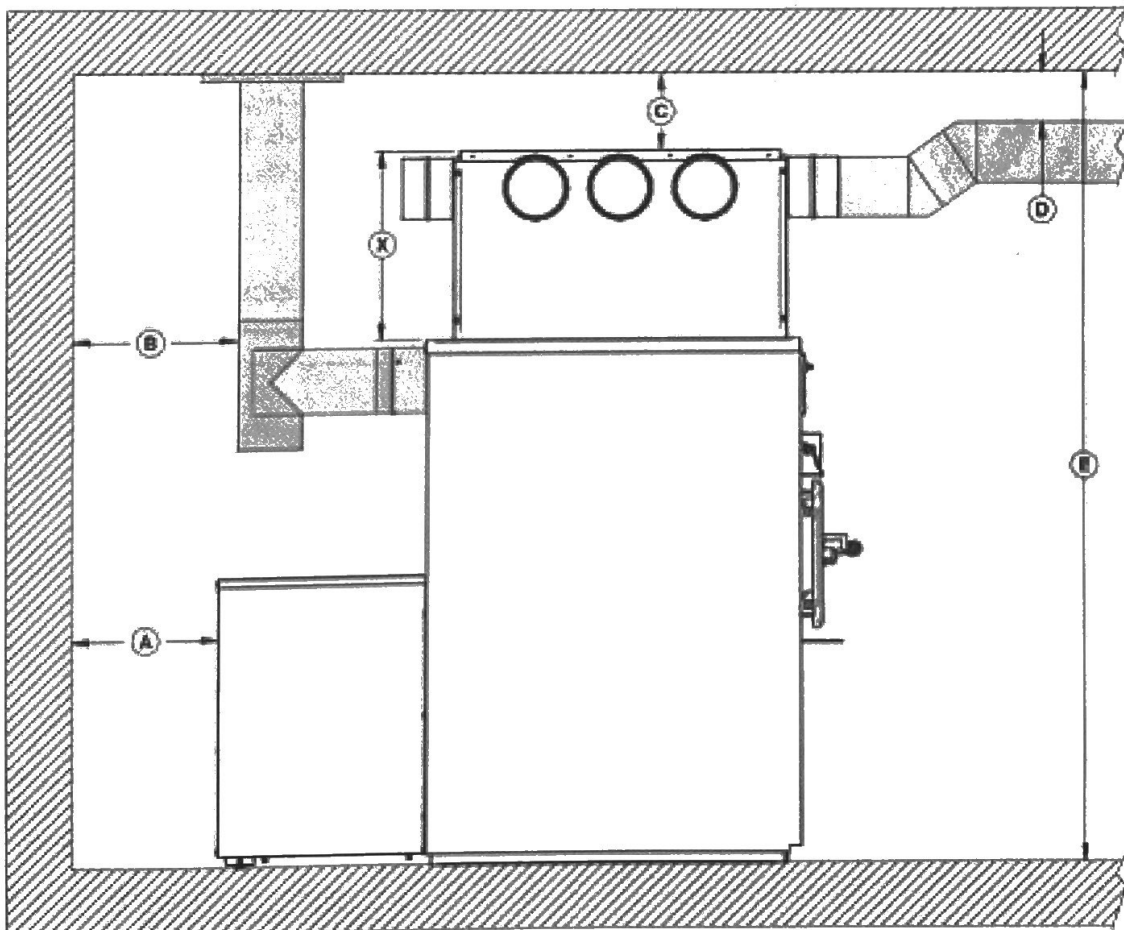

5.4.2 Installing the start-off adapters

After choosing your output configuration, do the following to install the start-off adapters.

Warning: Use gloves to complete the following steps because the start-off adapters and caps can be sharp.

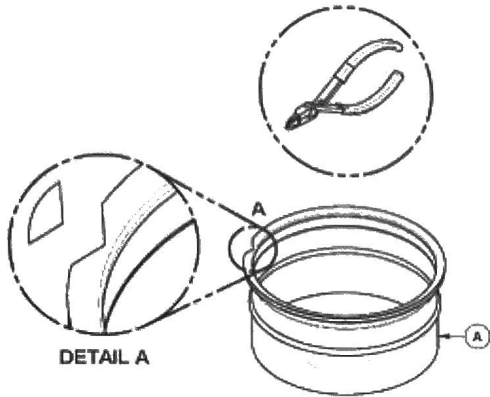

- 1- Cut a notch in the flange of adapter (A) and slightly fold down one side of the flange to facilitate installation.



- 2- Align the notch previously made on the adapter (A) with the one of the hot air outlet on the plenum, and then turn the adapter until the flange is completely inserted and rotates freely. Repeat the above procedure for the other adapters

5.4.3 Minimum amount of outlets and maximum lengths of ducts

- A minimum of 6 start-off adapters must be installed on the start-off plenum. The location of the adapters has no impact on the distribution of air.

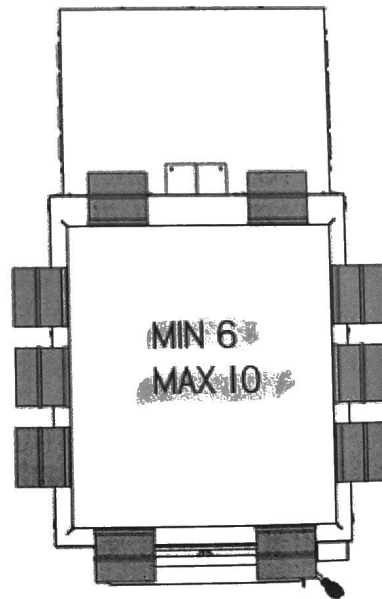

- Block the unused outlets with the block-off caps (B) and provided screws (D).

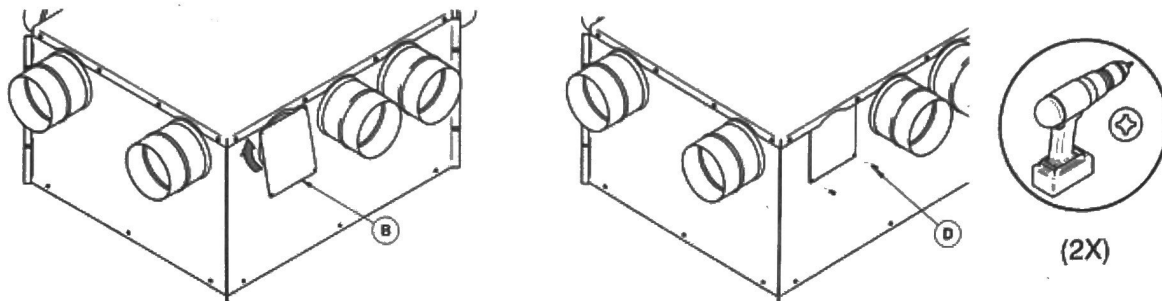

FAVOR THE USE RIGID DUCTS BECAUSE THERE ARE LESS RESTRICTIVE TO AIR FLOW.

- The maximum run of a main duct is 35' (10.7 m). It must be reduced from 6" (152 mm) to 5" (127 mm) after 20' (6.1 m) or reduce the main duct by 1" (25 mm) at every two secondary duct outputs.
- The maximum length of all the main ducts is 180' (54.9 m).
- The maximum run of a secondary duct is 10' (3 m).
- The maximum length of all the secondary ducts is 100' (30 m).
- The finishing grill at the output of a secondary pipe must be made of metal.

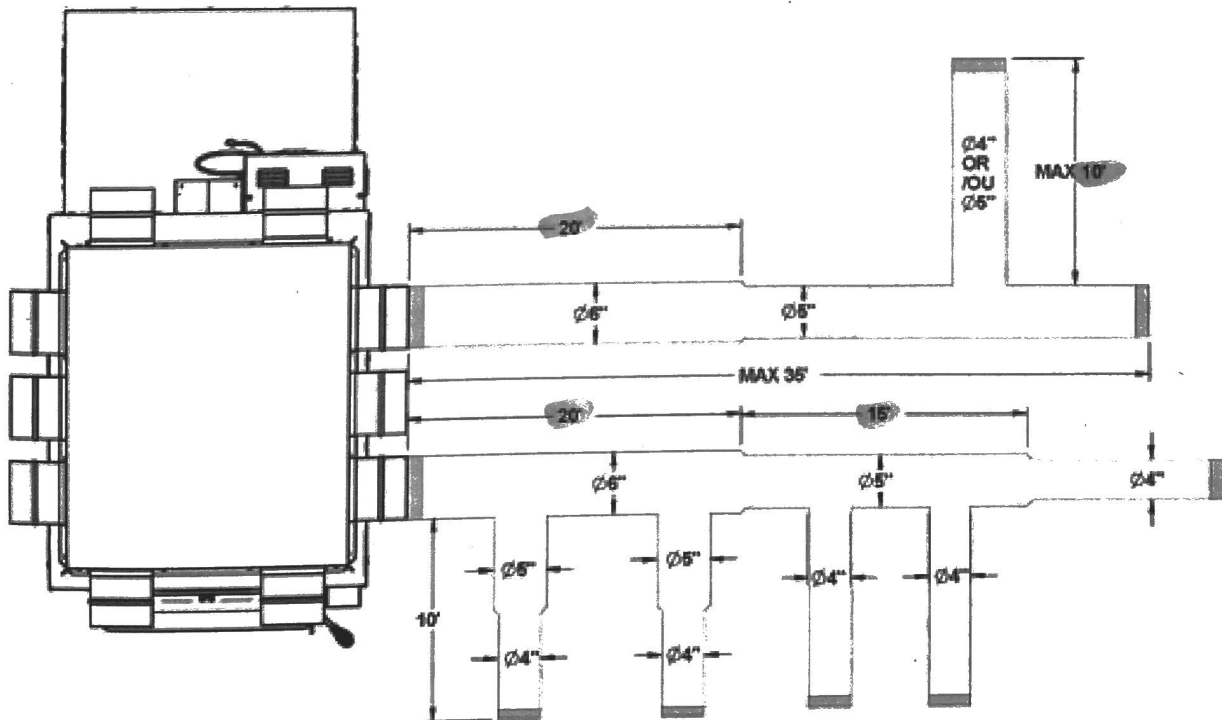

The total area of secondary duct outlets must be equal or slightly less than the total area of the outlets used on the distribution plenum **(B)**.

Example of surface calculation according to the number of outlets used in the plenum:

Diameter of plenum outlet (in)	Surface of plenum outlet (in ²)	Number of outlets on the plenum	Total surface of plenum outlets used (in ²)
6	28	6	170

The acceptable total area of secondary outlets would therefore be:

Diameter of secondary outlet (in)	Surface of secondary outlet (in ²)	Number of secondary outlets	Total surface of secondary outlets used (in ²)
4	12.5	9	112.5
5	19.5	1	19.5
6	28	1	28
The total area of the secondary outlets of this system would be acceptable because it is equal to or slightly less than the total area of the plenum outlets.			160

ACORDING TO THE NATIONAL BUILDING CODE, THE BTU/H PROVIDED BY AN OUTLET ON THE PLENUM MUST NOT EXCEED 10,250 BTU/H (3kW) AND THE HOT AIR TEMPERATURE AT THE OUTLET OF A SECONDARY DUCT SHOULD NOT EXCEED 158 °F (70 °C).

Once your hot air distribution system is installed, make sure to measure the static pressure in the start-off plenum. Adjust the opening at the end of each of distribution duct with a shutter until you get a static pressure 0.2" W.C. (50 Pa) at the plenum

The default blower speeds can be changed depending on the restriction created by the configuration of your distribution system (see **Section 13.3: Blower technical Data**).

5.5 Air return system and filter

The installation of an optional air return duct connected to the blower housing will improve the air circulation throughout the house (see **Appendix 3: Optional Fresh air return adapter (AC01392)**). The use of the air filter option is also recommended. The filter option will significantly reduce dust circulation within the hot air duct and will prevent obstruction of the blower (see **Appendix 2: Optional air filters (AC01390, AC01391)**).

ADD A 4" COLD AIR INTAKE.

6 Combustion air

CAUTION

WARNING: SUFFICIENT COMBUSTION AIR MUST BE AVAILABLE AT ALL TIMES; LACK OF COMBUSTION AIR CONSTITUTES A DANGER.

A CARBON MONOXIDE (CO) DETECTOR/ALARM IS REQUIRED IN THE ROOM IN WHICH THE FURNACE IS INSTALLED.

A fresh air supply may be necessary to prevent solid fuel units from rejecting products of combustion into the house.

Additional combustion air can be provided following the following methods, provided that they satisfy chapter 4 of the **CSA B365 standard for Canada**:

- **Direct combustion air supply:**

- o **The HeatPro is not certified** to be connected directly to a new combustion air supply. (NEEDS TO BE CLOSE BUT NOT CONNECTED) 2 4" TUBES

- **Indirect combustion air supply:** (TUBES CLOSED FOR NOW) MAY NOT BE NEEDED.

- o New combustion air can be brought into a pipe located within **approximately 12" (305 mm)** of the unit. If the pipe is too close to the furnace, it may interfere with its operation;
- *o **The recommended diameter of the outside air intake pipe is 4" (102 mm);** (WE HAVE 2 4" PER MIKE & LONER-GANS)
- o Mechanical ventilation system: if the house is equipped with a ventilation system (air exchanger or heat recovery), the ventilation system may provide sufficient auxiliary air to the solid fuel unit. Otherwise, the owner should be informed that the ventilation system may have to be rebalanced by a ventilation technician after the installation of the solid fuel unit;

7 Electrical connection, adjustment of components and calibration of the draw

The furnace is fully assembled at the factory and no electrical connection is required other than plugging the power cord into an outlet.

7.1 Raccordement électrique

The following instructions do not replace those of the local code.

Installation and verification of this appliance must be done by a qualified person.

All wiring from the service panel to the heating unit must comply with the electrical code in force and all local regulations. It is recommended to feed the furnace with its own electrical circuit of 15 amps at 120 volts with a breaker (see wiring diagram).

WARNING

ONLY USE WIRES SUITABLE FOR 167 °F (75 °C) OR MORE.

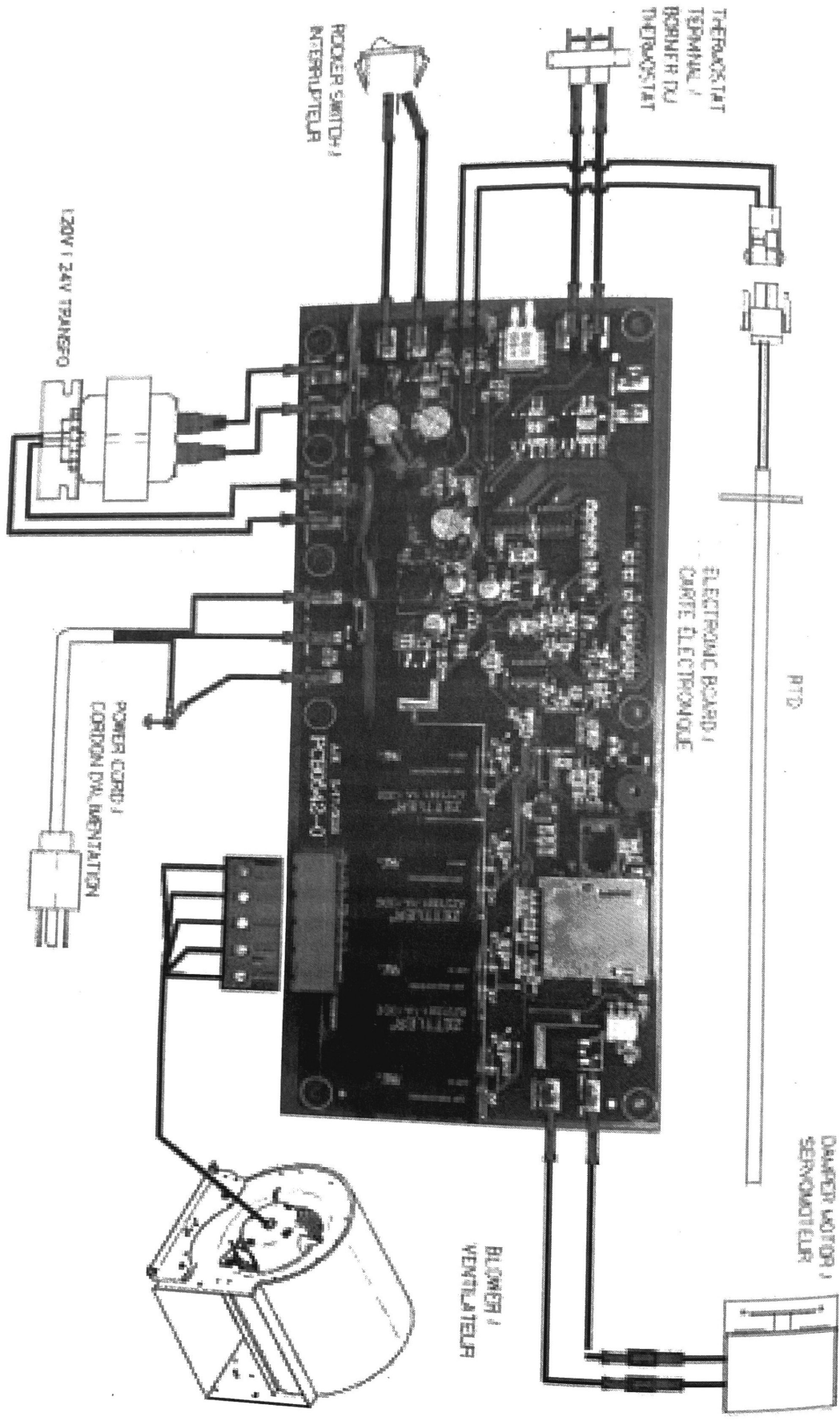

7.2 Installation and connection of the "RTD" thermal probe

IMPORTANT: The proper positioning of the "RTD" thermal probe is essential to the proper functioning of the furnace. Install it in the opening provided for this purpose on the start-off plenum.

With the plenum extension (A) and the plenum (B)

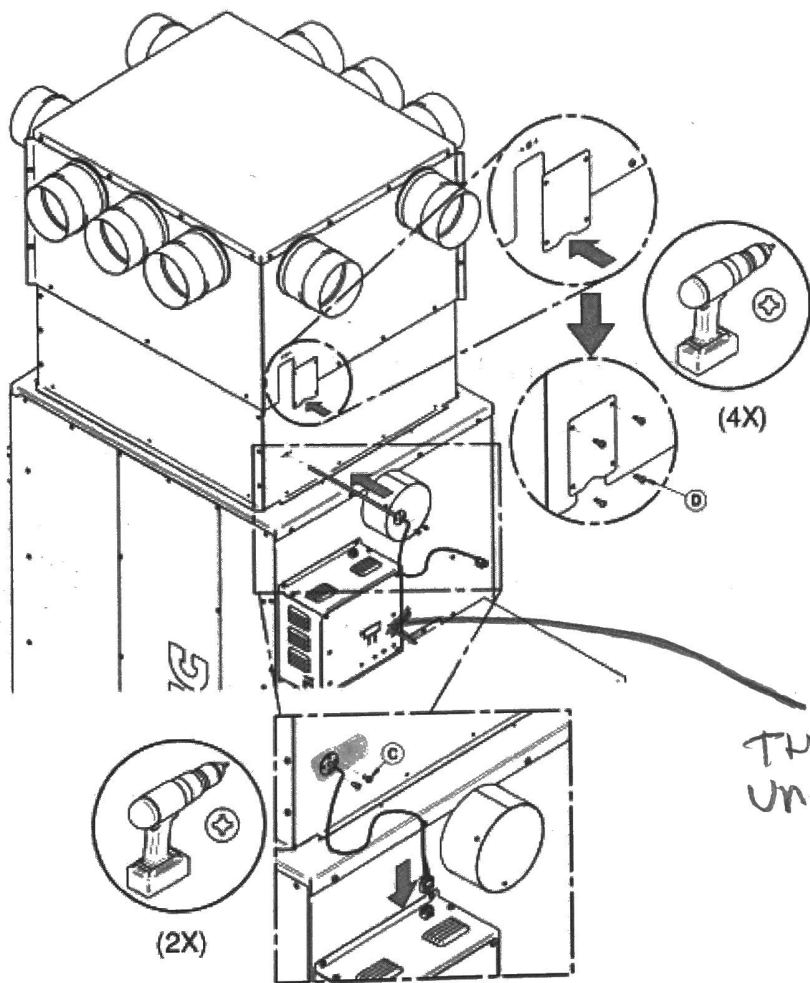

With 4 self-taping screws (D), install the metal plate on the plenum (B) to block-off the 3 holes. Make sure the notch towards the bottom.

Install the RTP probe in the plenum extension (A).

Secure the RTD probe with the two screws provided (C).

Connect the RTD probe on the furnace with the connection.

NEVE EVER TAKE THIS COVER OFF WHILE UNIT IS PLUGGED IN !!!

With plenum (B) only

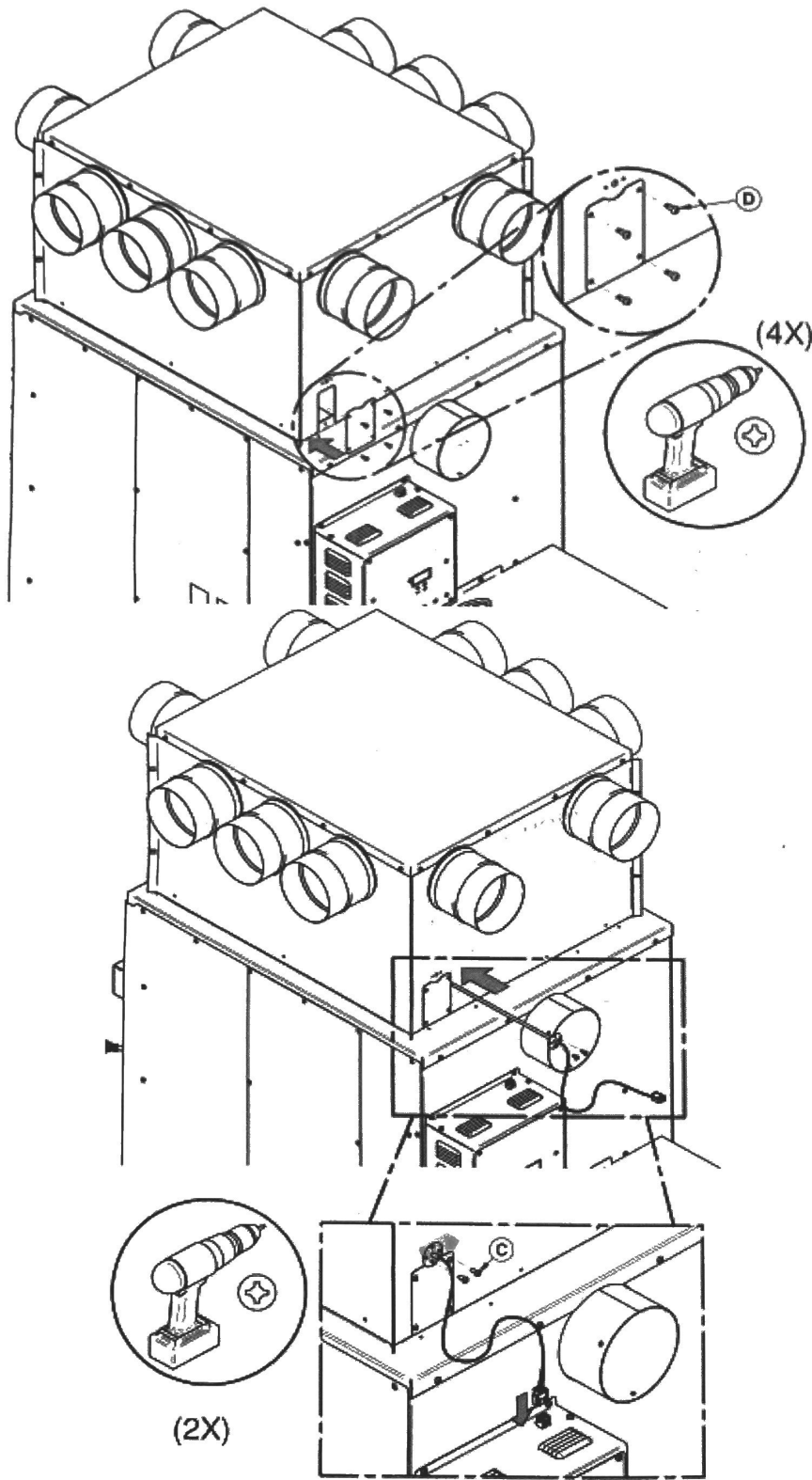

Using four self-drilling screws (D), install the plate supplied with the furnace on the plenum (B). Make sure to have the notch on the plate up.

Install the RTD probe in the hole of the plenum (B).

Secure the RTD probe with two screws (C).

Connect the RTD probe to the furnace with the connector.

7.3 Blower technical Data

The blower speed must conform to the recommendations of the Warm Air Heating and Air Conditioning National Association and should respect the static pressure ranges in the warm air plenum of the furnace.

MODEL	(DIRECT DRIVE)			FLOW (CFM)	TEMP VAR. (°F)	BTU/ H (WOOD)	STATIC PRESSURE INCH OF W.C.	OPTIONAL FILTER (IN)
	VENT	MOT.	VIT.					
HEATPRO	DD-10	1/3	4	1900	135	180,000	0,2	20" x 15" x 1"

Blower speed	Static pressure (in. WC) / (Pa)	Flow (CFM)
1	0.2 / 50	1136
2	0.2 / 50	1686
3	0.2 / 50	1790
4	0.2 / 50	1900

Volts	Amps	Max Amps	Hertz	Watts
120	3.6	5.0	60	432

7.4 Draw Calibration

The draw: The measurement is taken in the exhaust pipe 18 inches (457 mm) above the furnace's flue collar with a tube and a pressure gauge (manometer).

- **Poor: -0.03" W.C. (7.5 Pa) and under:** ignition problems, risk of smoke spillage, low performance of heat exchangers.
- **Ideal: from -0.04" to -0.06" W.C. (10 to 15 Pa):** To obtain the optimum performance of the furnace.
 - o A barometric draft control is not required.
- **Excessive: -0.08" W.C. (20 Pa) : WARNING**

This leads to premature wear of the furnace, a situation that is not covered by warranty.

- o A draw greater than -0.08" W.C. (20 Pa) leads to uncontrollable fire even if the air control is in closed position.
- o To prevent excessive draft, a barometric control must be installed to control excessive draft. It must be adjusted to the maximum draft of 0.06" W.C. (15 Pa) measured at the output of the furnace.

ET
3IVE
T
MP
FLUTE

TO

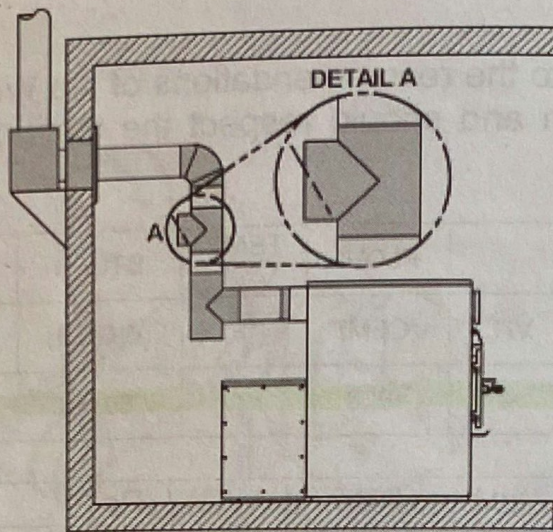

7.4.1 The use of a thermometer WE NEED THESE.

The first use of a thermometer is to inform the user about the discharge temperature of flue gases. Without accurate measurement of the draft using a pressure gauge (manometer), the thermometer will indicate if the temperature is ideal, too low or too high.

The use of a thermometer is therefore an acceptable alternative that can tell if the chimney is hot enough to generate an adequate draft.

- Use a magnetic thermometer for Single wall connector pipe;
- Use a probe thermometer for Double wall connector pipe.

Appendix 1: Optional thermostat installation *(NOT USEFUL FOR MEANY)* *(MANUAL ONLY)*

Using a thermostat will help you maintain a constant temperature throughout the house. A fixed wall mounted 24v thermostat is required.

Note: Thermostat manufacturer's instruction always overrides the information published in the following section.

Thermostat location

- Must be installed on an inside wall of the house;
- Where it will be the least affected by air currents from a hot air outlet or cold outside walls;
- Must be installed at a minimum of 55" (140 cm) above the floor;
- Must be installed at a minimum of 15' (4.57 m) from the furnace and must not receive radiation from the glass door.

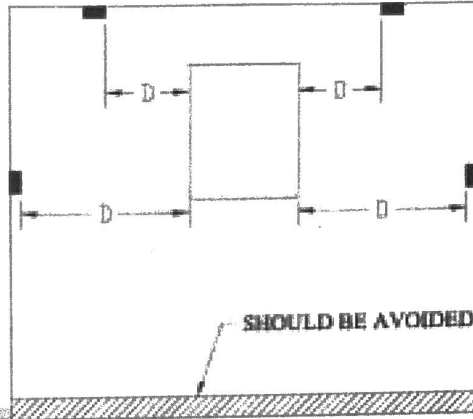

D = MINIMUM DISTANCE 15 FEET

Thermostat wiring

Before installing the thermostat, disconnect the furnace from the outlet;

Use an 18 AWG 2 strand wire.

The terminal is located at the back on the rear right side of the furnace when facing it. It is marked with the letter 'T'.

Loosen the two screws in the middle of the terminal bloc and insert the wires in the terminals. Tighten the two screws.

Open the thermostat housing and connect the wires following the manufacturer's instructions.

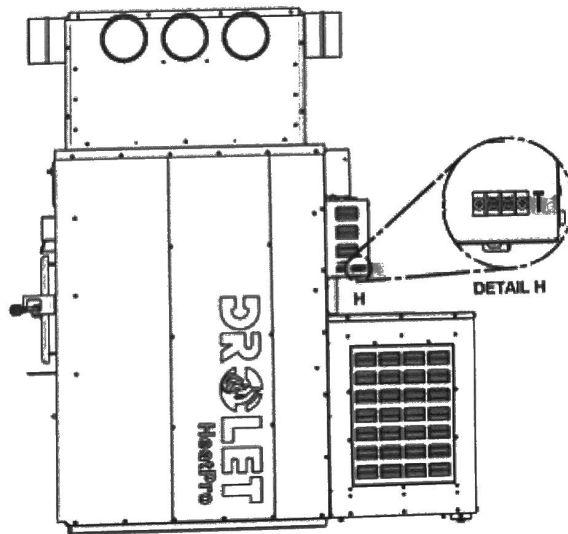

SET

RESISTIVE AT TEMP (ATUICE)

TO

Example of thermostat wiring:

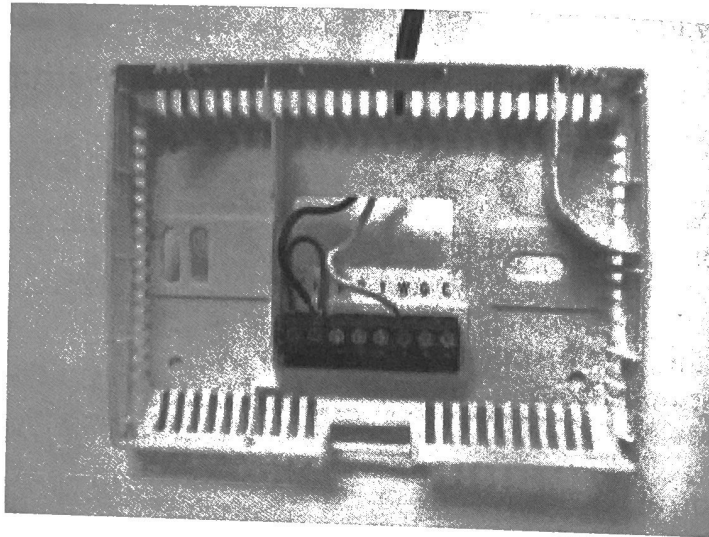

~~Connect one wire to "HR" and the other wire to "W".~~ The red jumper can be left in place. For more information, refer to the manufacturer's instructions.

This furnace may be installed in parallel as an add-on to an existing furnace in the USA only. Such an installation requires that the furnace's controls be interlocked to prevent both furnaces from heating at maximum rate simultaneously.

In order to interlock the furnaces, connect the wires from the existing furnace's thermostat, normally R and W, to the terminal identified "INTERLOCK" located next to the thermostat terminal of the HeatPro.

When the wood furnace receives the signal from the existing furnace's thermostat calling for heat, it will disconnect the damper motor, sending the wood furnace in low burn until the call for heat from that thermostat is satisfied.

After the existing furnace's thermostat is satisfied, the wood furnace will return under the control of its own thermostat.

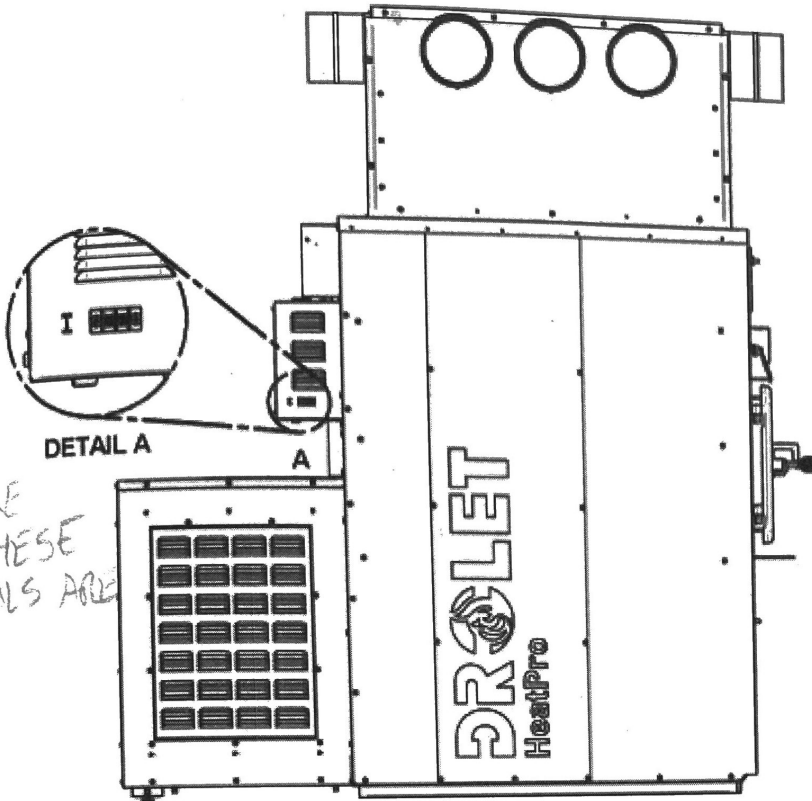

ENSURE
WHAT THESE
TERMINALS ARE

* REMOVED. (USING OVER-RIDE MANUAL ONLY)



Use in thermostat mode

To ensure proper operation of the air inlet damper while connected to a thermostat, the manual control switch must be maintained in the closed position. However, when a thermostat is connected to the furnace, it is still possible to use the manual control switch to open the air damper if desired. Even though you chose to control the furnace with a thermostat it is still possible to use the manual control switch to open the air intake damper if desired.

CHANGE WEEKLY! WE ARE VERY DIRTY AT MEANY

Appendix 2: Optional air filters (AC01390, AC01391)

The filter option (AC01390 – cardboard frame or AC01391 – washable aluminum) allows filtering dirt before distribution warm air in your installation in addition of protecting your blower. This system can be installed on any side of the blower box located behind the furnace on the most accessible side of your installation. This option includes the filter, the filter holder, two caps and the screws necessary for the installation.

Clean and replace filters as often as required.

Note: The operation cost is higher when using a dirty filter.

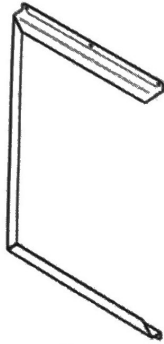

1 filter holder



2 caps

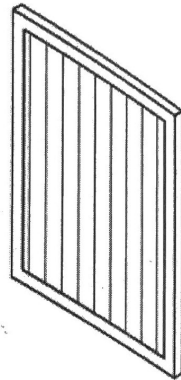

1 filter (15" x 20" x 1")

USE OILSTOVE LOW RESISTANCE FILTERS.

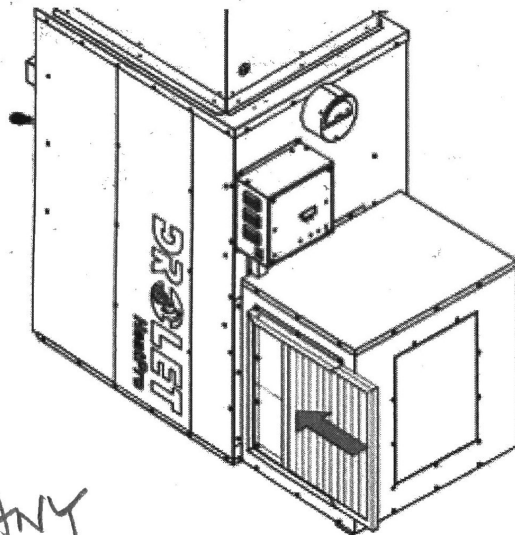

** NEVER! AT MEANY*

WARNING: IT IS NOT RECOMMENDED TO OPERATE THE FURNACE WITHOUT FILTERS. THIS APPLIES ESPECIALLY TO TEMPORARY HEATING DURING CONSTRUCTION PERIOD. OPERATING THE FURNACE WITHOUT FILTERS WOULD ALLOW DUST AND OTHER PARTICLES IN THE AIR TO CIRCULATE FREELY AND TO PENETRATE INTO THE BLOWER AND MOTOR CARTERS, CAUSING SOME DEFECTS.

Appendix 3: Optional Fresh air return adapter (AC01392)

The optional air return adapter (AC01392) can be added to the furnace blower box to increase the efficiency of your system. This option allows you to take in the fresh air from the rooms connected to the return system and bring it back towards the furnace to be heated. This option can be installed on either one of the 3 sides of the blower box. Complete installation instruction can be found in the instruction booklet provided when purchasing this option.

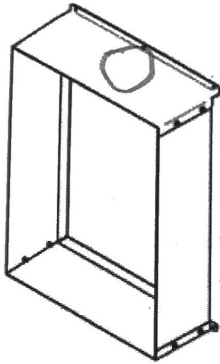

1 fresh air return adapter

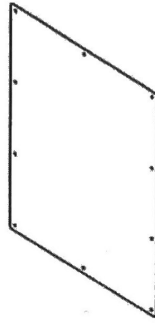

2 caps

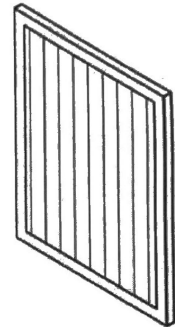

1 filter

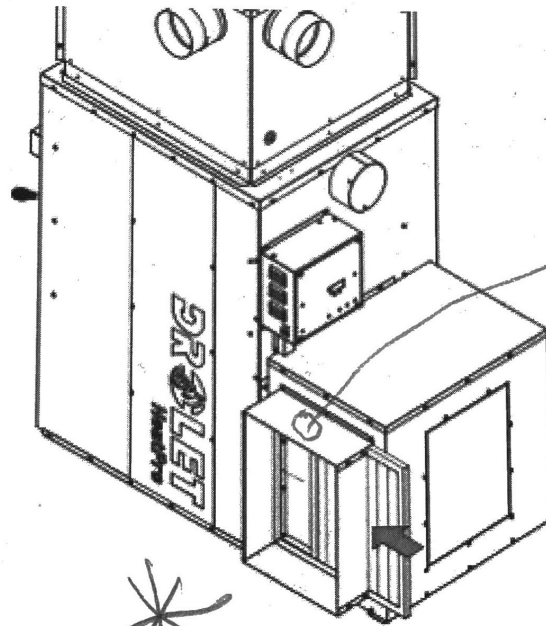

N.B. TO ENSURE ADEQUATE STATIC PRESSURE, THE SYSTEM SHOULD BE BUILT IN A WAY THAT THE VOLUME OF COLD AIR RETURN IS AT LEAST EQUAL OR SLIGHTLY HIGHER THAN THE VOLUME OF THE HOT AIR DISTRIBUTION.

PART 2 – OPERATION, MAINTENANCE AND TROUBLESHOOTING

Please see **Part 1** for installation instructions.

Please see **Part 3** for features and safety instructions.

7.5 How to prepare or buy good firewood

* 7.5.1 What is good firewood? 15-20% MOISTURE

Good firewood has been cut to the correct length for the furnace, split to a range of sizes and stacked in the open until its moisture content is reduced to 15 to 20 per cent.

* 7.5.2 Tree species FIR IS MED. DENSE WOOD.

The tree species the firewood is produced from is less important than its moisture content. The main difference in firewood from various tree species is the density of the wood. Hardwoods are denser than softwoods. People who live in the coldest regions of North America usually have only spruce, birch and poplar, other low-density species to burn and yet they can heat their homes successfully.

* Homeowners with access to both hardwood and softwood fuel sometimes use both types for different purposes. For example, softer woods make good fuel for relatively mild weather in spring and fall because they light quickly and produce less heat. Softwoods are not as dense as hardwoods so a given volume of wood contains less energy. Using softwoods avoids overheating the house, which can be a common problem with wood heating in moderate weather. Harder woods are best for colder winter weather when more heat and longer burn cycles are desirable.

Note that hardwood trees like oak, maple, ash and beech are slower growing and longer lived than softer woods like poplar and birch. That makes hardwood trees more valuable. The advice that only hardwoods are good to burn is outdated. Old, leaky cast iron furnaces wouldn't hold a fire overnight unless they were fed large pieces of hardwood. That is no longer true. You can successfully heat your home by using the less desirable tree species and give the forest a break at the same time.

* 7.5.3 Log length

Logs should be cut about 1" (25 mm) shorter than the firebox so they fit in easily. Pieces that are too long make loading the furnace very difficult. The most common standard length of firewood is 18" (406 mm).

The pieces should be a consistent length, with a maximum of 1" (25 mm) variation from piece to piece.

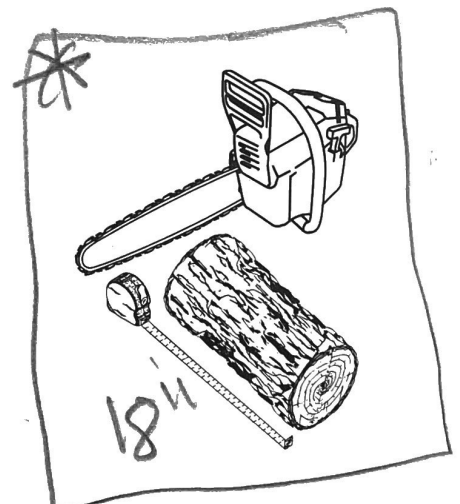

7.5.4 Piece size

Firewood dries more quickly when it is split. Large unsplit rounds can take years to dry enough to burn. Even when dried, unsplit logs are difficult to ignite because they don't have the sharp edges where the flames first catch. Logs as small as 3" (76 mm) should be split to encourage drying.

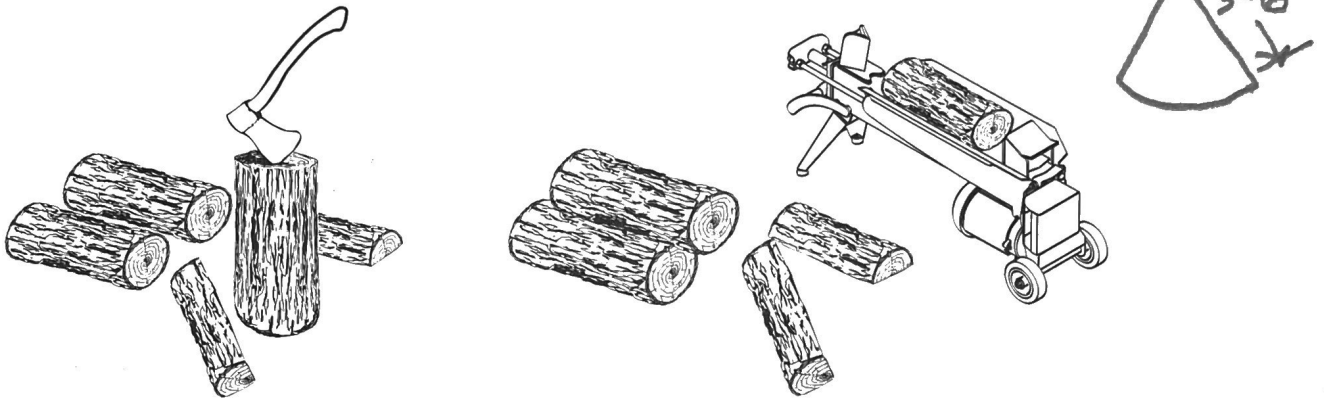

Wood should be split to a range of sizes, from about 3" to 6" (76 mm to 152 mm) in cross section. Having a range of sizes makes starting and rekindling fires much easier. Often, the firewood purchased from commercial suppliers is not split finely enough for convenient stoking. It is sometimes advisable to resplit the wood before stacking to dry.

7.5.5 How to dry firewood

Firewood that is not dry enough to burn is the cause of most complaints about wood inserts. Continually burning green or unseasoned wood produces more creosote and involves lack of heat and dirty glass door. See Section 4: **Maintaining your wood heating system** for concerns about creosote. ~~WIDE RUST OUT HEAT EXCHANGER~~

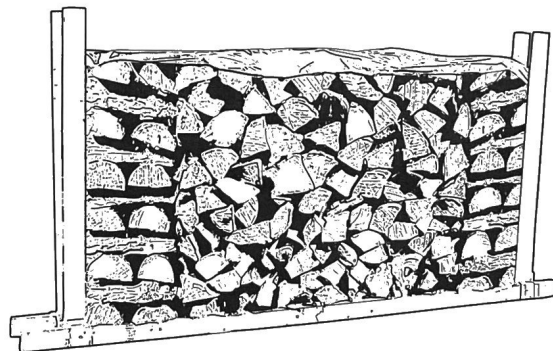

Here are some things to consider in estimating drying time:

- firewood takes a long time to dry
- firewood bought from a dealer is rarely dry enough to burn, so it is advisable to buy the wood in spring and dry it yourself
- drying happens faster in dry weather than in damp, maritime climates
- drying happens faster in warm summer weather than in winter weather
- small pieces dry more quickly than large pieces
- split pieces dry more quickly than unsplit rounds

- softwoods take less time to dry than hardwoods
- softwoods like pine, spruce, and poplar/aspen can be dry enough to burn after being stacked in the open for only the summer months
- hardwoods like oak, maple and ash can take one, or even two years to dry fully, especially if the pieces are big
- firewood dries more quickly when stacked in the open where it is exposed to sun and wind; it takes much longer to dry when stacked in a wood shed
- firewood that is ready to burn has a moisture content between 15 and 20% by weight and will allow your furnace to produce its highest possible efficiency



7.5.6 Judging firewood moisture content (METER/ IN WOODROOM)

You can find out if some firewood is dry enough to burn by using these guidelines:

- cracks form at the ends of logs as they dry
- as it dries in the sun, the wood turns from white or cream coloured to grey or yellow,
- bang two pieces of wood together; seasoned wood sounds hollow and wet wood sounds dull,
- dry wood is much lighter in weight than wet wood,
- split a piece, and if the fresh face feels warm and dry it is dry enough to burn; if it feels damp, it is too wet,
- burn a piece; wet wood hisses and sizzles in the fire and dry wood does not.

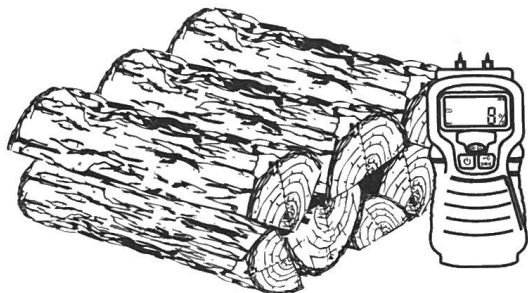

You could buy a wood moisture meter to test your firewood.

8 Operating your furnace

8.1 Your first fires

Two things will happen as you burn your first few fires; ~~the paint cures and the internal components of the furnace are conditioned.~~

As the paint cures, some of the chemicals vaporize. The vapours are not poisonous, but they do smell bad. Fresh paint fumes can also cause false alarms in smoke detectors. So, when you first light your furnace, be prepared by opening doors and/or windows to ventilate the house. As you burn hotter and hotter fires, more of the painted surfaces reach the curing temperature of the paint. The smell of curing paint does not disappear until you have burned one or two very hot fires.

It is recommended to burn it at high rate and ventilate the building until the odours disappear. Once the paint smell disappears, your furnace is ready for serious heating.

8.2 Lighting fires

Each person who heats with wood develops their own favourite method to light fires. Whatever method you choose, your goal should be to get a hot fire burning quickly. A fire that starts fast produces less smoke and deposits less creosote in the chimney. Here are three popular and effective ways to start wood fires.

8.2.1 Conventional fire starting

The conventional way to build a wood fire is to bunch up 5 to 10 sheets of plain newspaper and place them in the firebox. Next, place 10 or so pieces of fine kindling on the newspaper. This kindling should be very thin; less than 1" (25 mm). Next, place some larger kindling pieces on the fine kindling. Open the air control and light the newspaper. If you have a tall, straight venting system you should be able to close the door immediately and the fire will ignite. If your venting system has elbows or an outside chimney, you may need to leave the door closed but unlatched for a few minutes as the newspaper ignites and heat in the chimney produces some draft. Once the fire has ignited, close the door and leave the air control open.

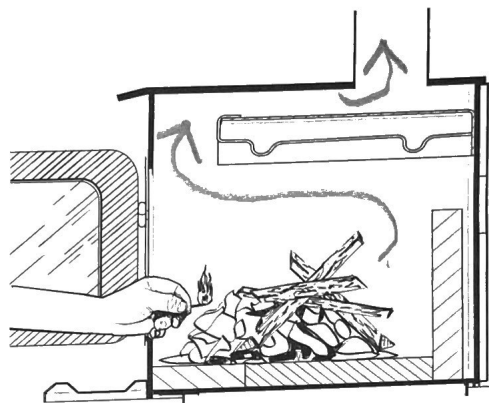

A conventional kindling fire with paper under finely split wood.

DO NOT LEAVE THE FURNACE UNATTENDED WHEN THE DOOR IS SLIGHTLY OPENED DURING IGNITION. ALWAYS CLOSE THE DOOR AFTER IGNITION.

After the kindling fire has mostly burned, you can add firewood pieces until you have a fire of the right size for the conditions.

8.2.2 The top down fire

The top down fire starting method solves two problems with the conventional method: first, it does not collapse and smother itself as it burns; and second, it is not necessary to build up the fire gradually because the firebox is loaded before the fire is lit. A top down fire can provide up to two hours of heating or more. The top down method only works properly if the wood is well-seasoned.

Start by placing three or four full-sized split pieces of dry firewood in the firebox. Next, place 4 or 5 more finely split pieces of firewood (2" to 3" (51 mm to 76 mm) diameter) on the base logs at right angles (log cabin style). Now place about 10 pieces of finely split kindling on the second layer at right angles.

The fire is topped with about 5 sheets of newspaper. You can just bunch them up and stuff them in between the kindling and the underside of the baffle. Or you can make newspaper

knots by rolling up single sheets corner to corner and tying a knot in them. The advantage of knots is that they don't roll off the fire as they burn. Light the newspaper and watch as the fire burns from top to bottom.

8.2.3 Two parallel logs

Place two spit logs in the firebox. Place a few sheets of twisted newspaper between the logs. Now place some fine kindling across the two logs and some larger kindling across those, log cabin style. Light the newspaper.

8.2.4 Using fire starters

Many people like to use commercial fire starters instead of newspaper. Some of these starters are made of sawdust and wax and others are specialized flammable solid chemicals. Follow the package directions for use.

Gel starter may be used but only if there are no hot embers present. Use only in a cold firebox to start a fire.

8.3 Maintaining wood fires

8.3.1 General advice

- * Wood heating is very different than other forms of heating.

Do not expect steady heat output from your furnace. It is normal for its temperature to rise after a new load of wood is ignited and for its temperature to gradually decline as the fire progresses. This rising and falling of temperature can be matched to your household routines. For example, the area temperature can be cooler when you are active, such as when doing housework or cooking, and it can be warmer when you are inactive, such as when reading or watching television.

- * Wood burns best in cycles. A cycle starts when a new load of wood is ignited by hot coals and ends when that load has been consumed down to a bed of charcoal about the same size as it was when the wood was loaded. Do not attempt to produce a steady heat output by placing a single log on the fire at regular intervals. Always place at least three, and preferably more, pieces on the fire at a time so that the heat radiated from one piece helps to ignite the pieces next to it. Each load of wood should provide several hours of heating. The size of each load can be matched to the amount of heat needed.

When you burn in cycles, you rarely need to open the furnace's loading door while the wood is burning. This is an advantage because there is more chance that smoke will leak from the furnace when the door is opened as a full fire is burning. This is especially true if the chimney connector has 90 degree elbows and if the chimney runs up the outside wall of the house.

- * **IF YOU MUST OPEN THE DOOR WHILE THE FUEL IS FLAMING, OPEN THE AIR CONTROL FULLY FOR A FEW MINUTES, THEN UNLATCH AND OPEN THE DOOR SLOWLY.**

IMPORTANT

WHEN RELOADING, MAKE SURE YOU KEEP THE AIR INLETS LOCATED AT THE BOTTOM OF THE DOOR INSIDE THE COMBUSTION CHAMBER FREE OF ASH.

OPENING PROCEDURE FOR THE LOADING DOOR
TO MINIMISE THE RISK OF SMOKE SPILLAGE, CRACK THE DOOR OPEN ABOUT AN INCH (25 MM) AND WAIT ABOUT 10 SECONDS BEFORE OPENING IT WIDE TO ALLOW STABILISATION OF THE PRESSURE INSIDE THE FURNACE.

8.3.2 Raking charcoal

Rekindle the fire when you notice that the room temperature has fallen. Do not operate your furnace at too low a setting. Keep the air inlet opened long enough during the fire start-up to prevent the fire from smouldering, which could stain the glass. You will find most of the remaining charcoal at the back of the firebox, furthest from the door. Rake these coals towards the door before loading. There are two reasons for this raking of the coals. First, it concentrates them near where most of the combustion air enters the firebox and where they can ignite the new load quickly, and second, the charcoal will not be smothered by the new load of wood. If you were to simply spread the charcoal out, the new load will smoulder for a long time before igniting.

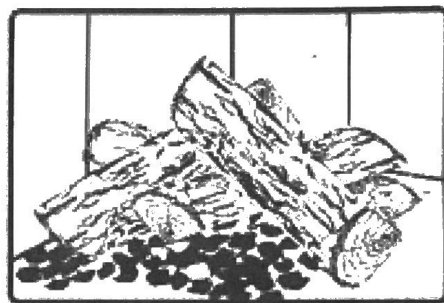
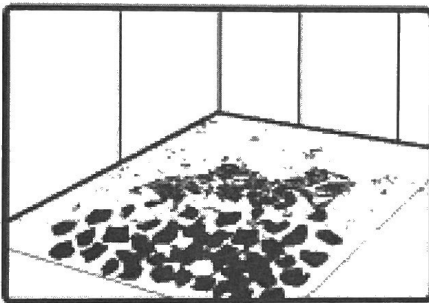
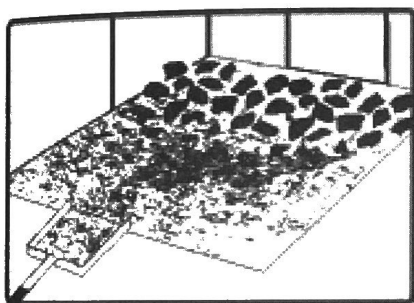

Remove ash first, and then rake charcoal towards the front of the firebox before loading so that it will ignite the new load.

8.3.3 Firing each new hot load

Place the new load of wood on and behind the charcoal, and not too close to the glass. Close the door and open the air control fully. Leave the air control fully open until the firebox is full of flames, the wood has charred to black and its edges are glowing red. Firing each load of wood hot accomplishes a few things:

- drives the surface moisture from the wood,
- creates a layer of char on the wood, which slows down its release of smoke,
- heats the firebox components so they reflect heat back to the fire, and
- heat the chimney so it can produce strong, steady draft for the rest of the cycle.

DO NOT LEAVE THE FURNACE UNATTENDED WHILE A NEW LOAD IS BEING FIRED HOT.

DO NOT OVERFIRE.

When you burn a new load of wood hot to heat up the wood, the furnace and the chimney, the result will be a surge of heat from the furnace. This heat surge is welcome when the

room temperature is a little lower than desirable, but not welcome if the space is already warm. Therefore, allow each load of wood to burn down so that the space begins to cool off a little before loading.

8.3.4 Control of the air supply

Once the firewood, firebox and chimney are hot, you can close the air supply for a steady burn.

If the flames get very small and almost disappear when you close the air, you have closed the air too early, or your firewood is wetter than it should be. With good fuel and correct air control use, the flames should slow down, but should stay large and steady, even as the air supply is closed.

WE DO NOT USE A THERMOSTAT.
When the furnace is using a thermostat, it is the thermostat that controls the air inlet damper. When the thermostat calls for heat, the damper opens and the combustion is stirred up. When the furnace gets hot enough, the blower motor is activated.

The following figure shows the position of the air inlet damper (A) according to the position of the air inlet damper switch (B).

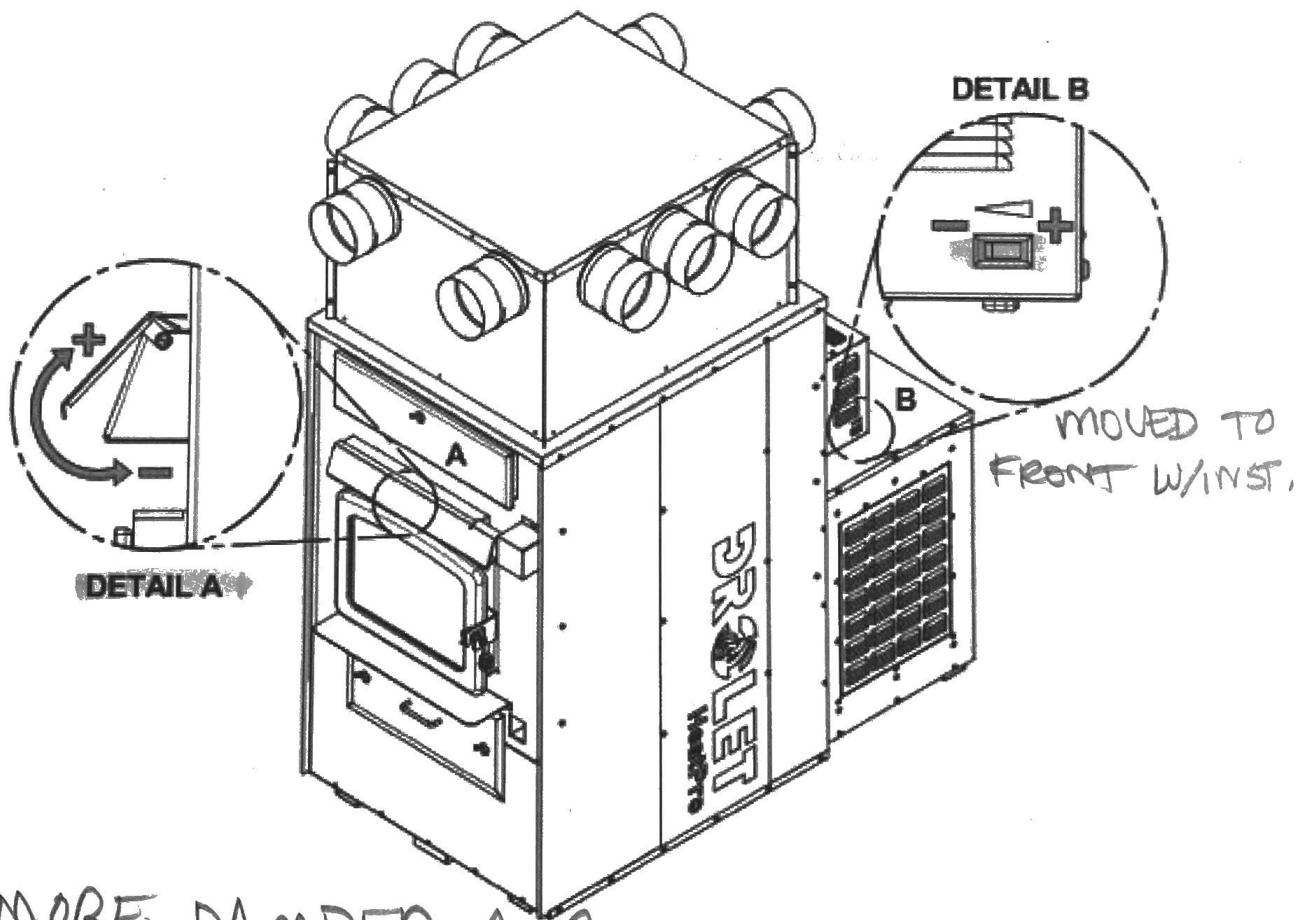

+ = MORE DAMPER AIR
- = LESS DAMPER AIR

8.3.5 Building different fires for different needs

Using the air control is not the only way to match the furnace's heat output to the heat demand. Your house will need far less heat in October than in January to be kept at a comfortable temperature. If you fill the firebox full in fall weather, you will either overheat the space or turn the furnace down so much that the fire will be smoky and inefficient. Here are some suggestions for building fires to match different heat demand.

8.3.5.1 Small fires to take the chill off the house

To build a small fire that will produce a low heat output, use small pieces of firewood and load them crisscross in the firebox. The pieces should be only 3" (76 mm) to 4" (102 mm) in diameter. After raking the coals, you can lay two pieces parallel to each other corner to corner in the firebox and lay two more across them in the other direction. Open the air control fully and only reduce the air after the wood is fully flaming. This kind of fire is good for mild weather when you are around to tend the furnace and should provide enough heat for four hours or more. Small fires like this are a good time to use softer wood species so there will be less chance of overheating the house.

8.3.5.2 Long lasting low output fires

Sometimes you will want to build a fire to last up to eight hours, but don't need intense heat. In this case use soft wood species and place the logs compactly in the firebox so the pieces are packed tightly together. You will need to fire the load hot for long enough to fully char the log surfaces before you can turn the air down. Make sure the fire is flaming brightly before leaving the fire to burn.

8.3.5.3 High output fires for cold weather

When the heat demand is high during cold weather, you'll need a fire that burns steadily and brightly. This is the time to use your biggest pieces of hardwood fuel if you have it. Put the biggest pieces at the back of the firebox and place the rest of the pieces compactly. A densely built fire like this will produce the longest burn your furnace is capable of.

You will need to be cautious when building fires like this because if the air is turned down too much, the fire could smoulder. Make sure the wood is flaming brightly before leaving the fire to burn.

8.3.5.4 Maximum burn cycle times

The burn cycle time is the period between loading wood on a coal bed and the consumption of that wood back to a coal bed of the same size. The flaming phase of the fire lasts for roughly the first half of the burn cycle and the second half is the coal bed phase during which there is little or no flame. The length of burn you can expect from your furnace, including both the flaming and coal bed phases, will be affected by a number of things, such as:

- firebox size,
- the amount of wood loaded,
- the species of wood you burn,
- the wood moisture content,
- the size of the space to be heated,

- the climate zone you live in, and
- the time of year.
- the time cycle for the thermostat to call for heat.

The table below provides a very general indication of the maximum burn cycle times you are likely to experience, based on firebox volume.

BOX FULL
OF
CINDER/ASH.
↑
↓
CLEAN BOX

FIREBOX VOLUME	MAXIMUM BURN TIME
<1.5 cubic feet	3 to 5 hours
1.5 c.f. to 2.0 c.f.	5 to 6 hours
2.0 c.f. to 2.5 c.f.	6 to 8 hours
2.5 c.f. to 3.0 c.f.	8 to 9 hours
>3.0 c.f.	9 to 10 hours

8.3.6 Control of the air inlet damper

Always turn the furnace on with the air inlet damper open. Once the temperature of the wood, the combustion chamber and the chimney is stable, close the air inlet damper to obtain a more efficient combustion.

To control the air inlet damper, use the switch on the side of the control box located at the back of the furnace. (MOUNTED TO POSTS/INST. AT FRONT)

Reducing the combustion air will do two things. First, the combustion rate will decrease, which will spread the thermal energy of the fuel over a longer period of time. In addition, the velocity of the exhaust gas decreases, which allows better heat transfer in the heat exchanger and chimney.

The closure of the main air intake reduces the intensity of the flames which indicates the achievement of optimum performance. If the flames diminish in intensity at a point where it almost disappears, it is an indication that the air inlet damper was closed too soon or the firewood used is dry enough. If the wood is dry enough and the air control is closed when the unit is at a stable temperature, the flames will decrease but remain strong and stable to provide efficient heating.

8.4 Additional fresh air supply

When the furnace and the chimney are completely cold, it may be necessary to provide fresh air by opening a door or a window for a few minutes while lighting the fire.

* Take note that a house constructed or renovated in order to be airtight may lack the volume of fresh air necessary for the proper combustion of a solid-fuel heating appliance.

(WE DO NOT HAVE THIS ISSUE.)

In such a case, when starting up the fire, do not operate appliances that evacuate air outside the house, such as:

- Range hood
- Air exchanger
- Clothes dryer
- Bathroom blower
- Ventilated central vacuum system

Exhaust blowers that are in a fuel storage room should be installed so as not to create negative pressure in the room where the solid fuel appliance is located.

A fresh air supply may be necessary to prevent solid fuel units from rejecting products of combustion into the house. The indications used to determine if an additional fresh air supply is necessary are not appropriate for all the situations. When in doubt, it is recommended to install a fresh air supply.

A fresh air supply may be needed if:

- Solid fuel units present anomalies, such as irregular draft, smoke return, bad combustion, and/or reversed draft (whether there is combustion or not);
- Existing solid fuel units such as a stove or fireplace release odours, heat badly, cause smoke returns, or reversed draft (whether there is combustion or not);
- The opening of a window, even slightly, in calm weather (windless), eliminates every problem mentioned above;
- The house is equipped with a tight vapour barrier and adjusted windows, and/or is equipped with an interior air mechanical evacuation device;
- There is excessive condensation on the windows in winter; and
- The house is equipped with a ventilation system.

If, according to these symptoms or other similar ones, there is insufficient combustion air, it is necessary to ensure an additional combustion air supply (see **Section 12: Combustion Air**).

* 8.5 Manual or thermostat control

From factory, the opening and closing of the air inlet damper is manually activated by the means of a switch located at the rear of the furnace. The switch has two positions: opened and closed.

* MOVED TO POSTS WITH INSTRUCTIONS.

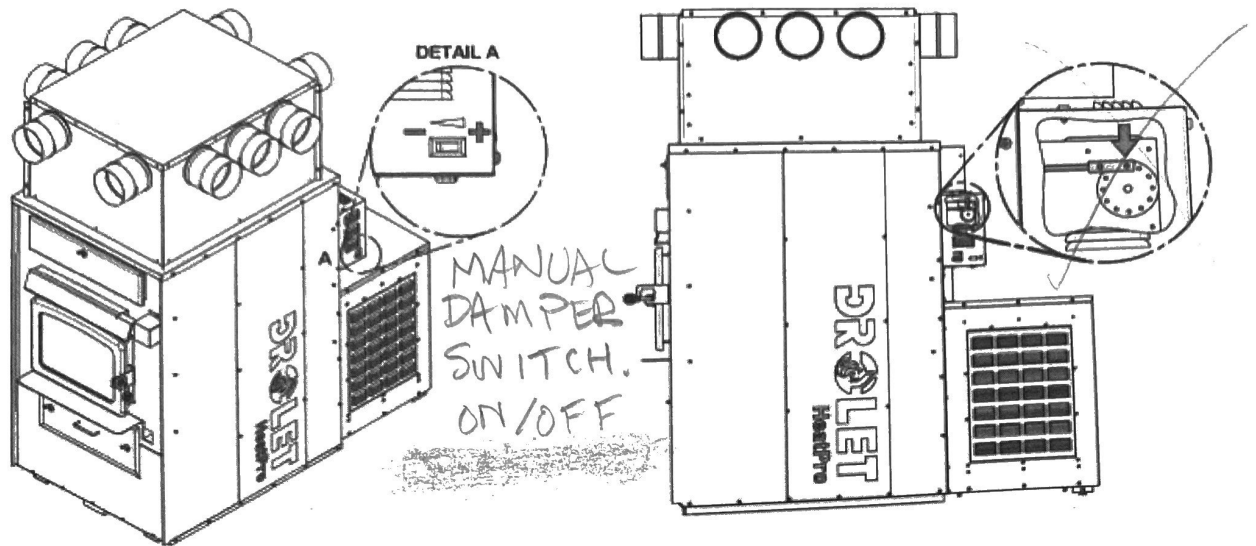

Position of the air control rod when the switch in the "closed" position.

For added comfort, the installation of an optional wall thermostat is recommended since it will open the air inlet damper when the room temperature is below the set point of the thermostat and will close the air inlet damper as the desired temperature is reached (see **Appendix 1: Optional Thermostat Installation**).

REMOVED. WE USE MANUAL SWITCH TO OPEN/CLOSE DAMPER.
 If the heat sensors detect any overheating in the air jacket of the furnace, the air inlet damper will close automatically regardless of the type of control used.

8.6 Ash drawer

Your furnace is equipped with an ash drawer to collect ashes produced by the combustion of wood. The ash drawer is provided with two (2) wing nuts to hold the door in a close position. Operating the furnace with the ash drawer open may seriously damage the furnace. **The drawer must be emptied regularly.**

8.7 Prolonged power outage 10 MIN. +

To reduce the risk of overheating during a prolonged power outage (more than 10 minutes), it is recommended damper is closed. If your furnace is equipped with the optional filter, remove the air filter to improve the circulation of air around the combustion chamber of the furnace. Do not load the furnace more than 50 percent of its capacity to prevent the risk of overheating.

GENERATOR SHOULD BE USED AGAIN WHEN POWER GOES OUT.

9 Maintaining your wood heating system

9.1 Furnace maintenance

Your new furnace will give many years of reliable service if you use and maintain it correctly. Some of the internal components of the firebox, such as firebricks, baffles and air tubes, will wear over time under intense heat. You should always replace defective parts with original parts (see **Section 6: Exploded diagram and parts list**). For firing each load hot to begin a cycle as described above will not cause premature deterioration of the furnace. However, letting the furnace run with the air control fully open for entire cycles can cause damage over time. The hotter you run the furnace throughout burn cycles, the more quickly its components will deteriorate. For that reason, **never leave the furnace unattended while a new load is being fired hot.**

9.1.1 Ash removal

Ash should be removed from the firebox every two or three days of full time heating. Do not let the ash build up in the firebox because it will interfere with proper fire management.

The best time to remove ash is after an overnight fire when the furnace is relatively cool, but there is still some chimney draft to draw the ash dust into the furnace and prevent it from coming into the room.

After ashes have been removed from the furnace and placed in a tightly covered metal container, they should be taken outside immediately. The closed container of ashes should be placed on a non-combustible floor or on the ground well away from all combustible materials pending final disposal. Ashes normally contain some live charcoal that can stay hot for several days. If the ashes are disposed of by burial in soil or otherwise locally dispersed, they should be retained in the closed container until all cinders have thoroughly cooled. Other waste shall not be placed in this container.

NEVER STORE ASHES INDOORS OR IN A NON-METALIC CONTAINER OR ON A WOODEN DECK. ALWAYS LEAVE THE CONTAINER ON A NON COMBUSTIBLE FLOOR.

9.1.2 Cleaning door glass

~~Under normal conditions, your door glass should stay relatively clear. If your firewood is dry enough and you follow the operating instructions in this manual, a whitish, dusty deposit will form on the inside of the glass after a week or so of use. This is normal and can be easily removed when the furnace is cool by wiping with a damp cloth or paper towel and then drying.~~ **Never try to clean the glass when the furnace is hot.**

~~In spring and fall the furnace will cycle less often. You may see some light brown stains forming, especially at the lower corners of the glass. This indicates that the combustion has been incomplete and some of the smoke has condensed on the glass. When the weather is mild, you may find that letting the fire go out is better than trying to maintain a continuous fire. Use the technique described above for building a fire to take the chill off the house.~~

USE WOOD STOVE GLASS DOOR CLEANER ONLY.

If you do get brown stains on the glass you can remove them with special cleaners for wood furnace glass doors. **Do not use abrasives to clean your furnace's door glass.**

The deposits that form on the glass are the best indication of the quality of your fuel and how well you are doing in operating the furnace. Your goal should be clear glass with no brown stains. If you continue to see brown stains on the glass, something about your fuel and operating procedure needs to be changed. Stains on the glass indicate incomplete combustion of the wood, which also means more smoke emissions and faster formation of creosote in the chimney.

If you see brown streaks coming from the edge of the glass, it is time to replace the gasket around the glass. Visit your furnace retailer to get the self-adhesive glass gasket and follow the **Section 4.1.4: Replacement of the glass and gaskets** instructions for installation.

- Check the glass regularly to detect any crack or damage. Replace damaged glass immediately; do not use the furnace with a broken glass.

9.1.3 Door adjustment

In order for your furnace to burn at its best efficiency, the door must provide a perfect seal with the firebox. Therefore, the gasket should be inspected periodically making sure to obtain an air tight fit. Air tightness can be improved with a simple latch mechanism adjustment. If the adjustment is not sufficient, replace the door gasket with a new one (see **Section 4.1.4: Replacement of the glass and gaskets**). *EVERY FEW YEARS.*

Door adjustment procedure

1. Unscrew the locking pin (B) and nut (A) from the door (see image below).
2. To increase the pressure of the door on the gasket, turn the handle. Counter-clockwise, to reduce the pressure of the door on the cord, turn the handle clockwise to clockwise.
3. Finally, screw-in the locking pin (B) about 1/4" (6 mm) deep and make sure you lock it with the nut (A).

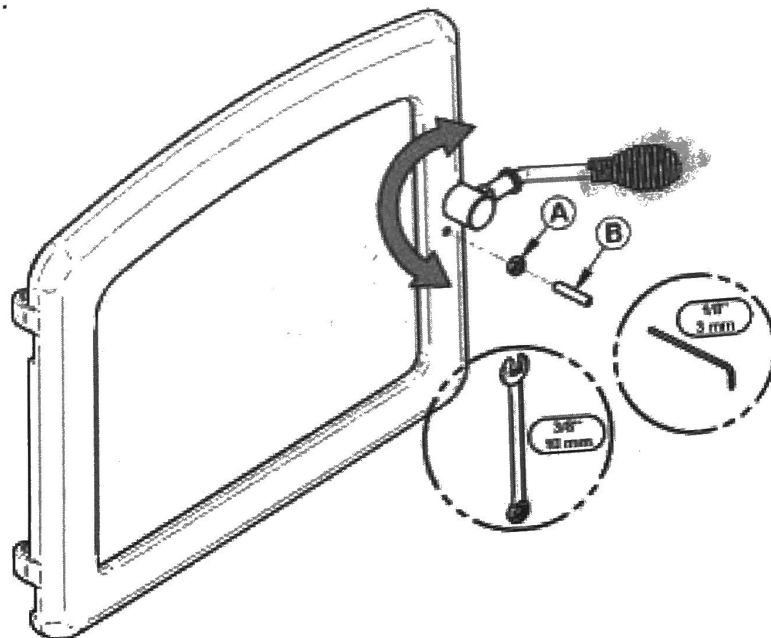

9.1.4 Replacement of the glass and gaskets

After a year or more of use, the gasket of the door will compress and become hard which can allow air to pass. You can check the air tightness of your door gasket by closing and locking the door on a piece of paper. Check all around the door. If the paper slides easily anywhere, it is time to replace the gasket.

Use a good quality gasket that you can purchase from your dealer. The correct size and density of the gasket are important to ensure a good seal.

Prior of removing the defective glass, you need to remove the door gasket. Inspect the door gasket before it is reinstalled to make sure it is in good condition. We suggest replacing the door and glass gasket at the same time as their level of wear over time is similar.

For the following steps, wearing gloves and safety glasses are recommended for handling seals can irritate the skin and the glass can be sharp.

- To replace the door gasket, use the steps 1 to 3 and 10 outlined below;
 - To replace the glass, use the steps 1 to 6 and 9 to 10 outlined below;
 - To replace the glass gasket, use the steps 1 to 10 outlined below;
1. Remove the door **(F)** and place it on a stable work surface, handle down.
 2. Using pliers, remove the door gasket **(A)**.
 3. Using a scraper or a small flat screwdriver, remove the adhesive left in the gasket groove in the door then clean the surface using a commercial vacuum.
 4. Use a Phillips screwdriver or a power drill to remove the screws **(B)** that holds the glass retainer **(C)**.
 5. Remove the glass frame **(D)**
 6. Remove the glass **(E)** (or pieces of glass if it is damaged) and clean the inside of the door frame.
 7. Remove the old glass gasket.
 8. Install the new gasket on the glass. Remove a part of the paper covering the gasket adhesive. Center the gasket on the edge of the glass so that when folded and glued, the gasket is equal on both sides. Do not stretch the gasket during installation. Remove a majority of the paper, turn the glass to facilitate and complete the installation of the gasket. When you return to the starting point, cut the gasket so that the ends overlap by about 1/2" (13 mm):

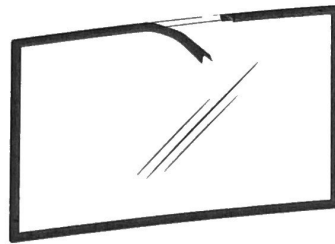

9. Install the glass (E) and glass frame (D) and centering it in the frame of the door and install the glass retainer frame (D) and glass retainers (C) taking care not to over-tighten the screws (B). Note that the two main causes of glass breakage are unequal position in the door and screws too tight.
10. Install the new door gasket (A). To do this, use about 1/4" (6 mm) of adhesive to the bottom of the groove that holds the gasket in the door. Then lay the new gasket starting from the center of the hinge side and taking care not to stretch the gasket during installation. Leave about 1/2" (13 mm) of gasket exceed the frame of the door. Once joined, push the fibers protruding towards the inside of the groove in the adhesive. Install the door and let dry for 24 hours before using the furnace.

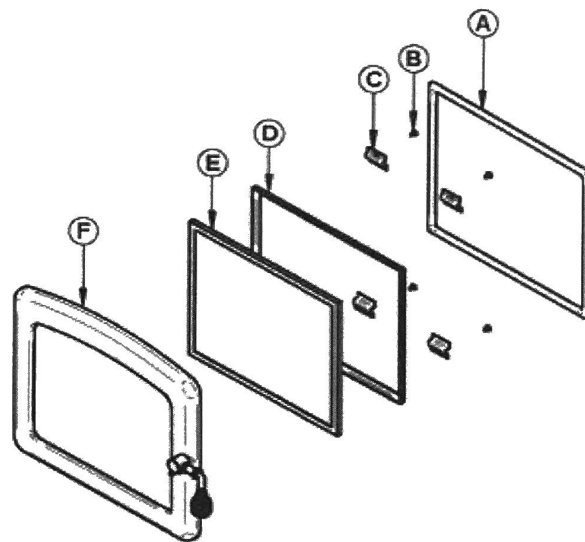

Do not abuse the glass door by striking or slamming shut. Do not use the furnace if the glass is broken. To change the glass, perform the same operation described above.

9.1.5 Cleaning and painting the furnace

Do not attempt to clean or paint the furnace when the unit is hot. Painted surfaces can be wiped down with a damp cloth. Plated or enameled surfaces may be scratched by abrasive cleaners. To maintain the finish at its original brilliance, use only a damp soft cloth to clean plated or enameled surfaces.

If the paint becomes scratched or damaged, you can give your wood furnace a brand new look by repainting it with heat-resistant or enamel finish paint. Before painting, roughen the surface with fine sand paper, wipe it down to remove dust, and apply two thin coats of

paint. For best results, use the same paint that was originally used on the furnace, which is available in spray cans. See your dealer for details.

9.1.6 Heat exchangers care (CLEAN TUBES 1X PER MO./OR WEEKLY,)

Heat exchangers must be cleaned thoroughly at the end of every heating season. During summer, the air in basements is damper and with minimal air circulation within the furnace, it can mix with creosote and/or soot deposits in the exchangers to form an acid that could accelerate the corrosion process and induce premature decay of the steel. Corrosion damages are not covered under warranty.

Smoke pipe and exchangers must be inspected regularly during the heating season. Access to the exchangers is easy and does not require tools;

1. Unscrew the wing nut (B) and remove the washer (C) on the exchanger access door (see Detail B).

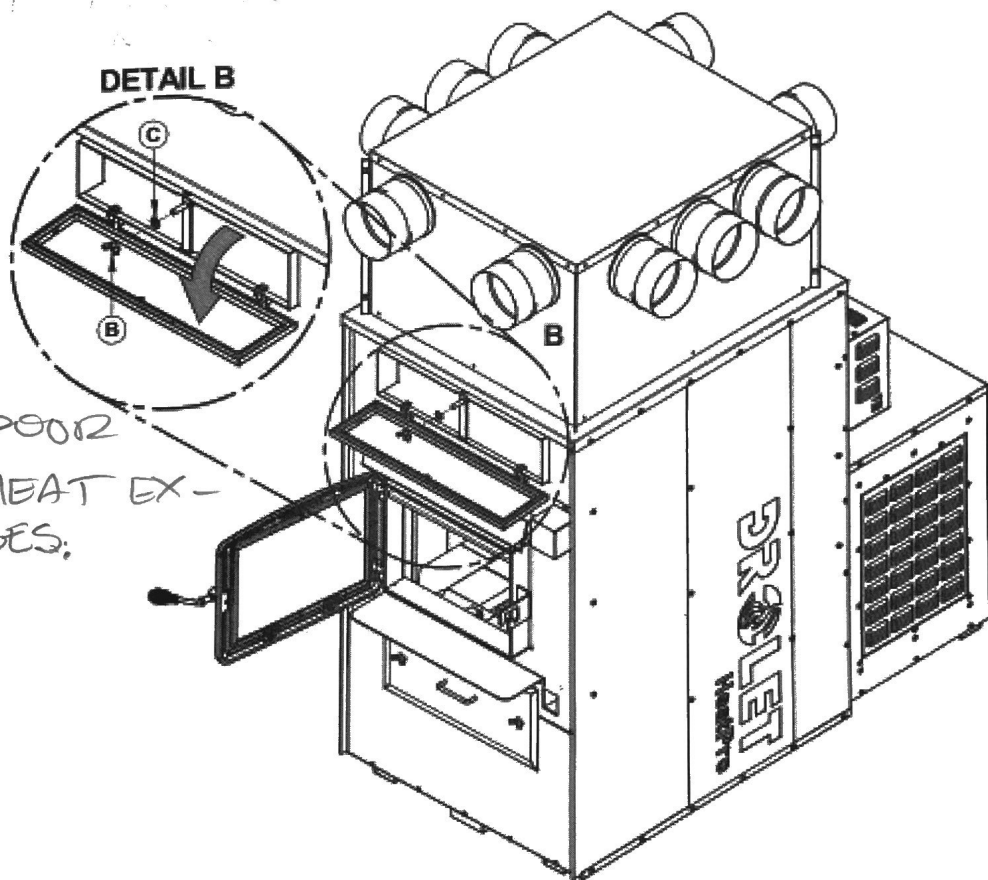

2. Move the baffle of the combustion chamber forward (see **Detail A**).

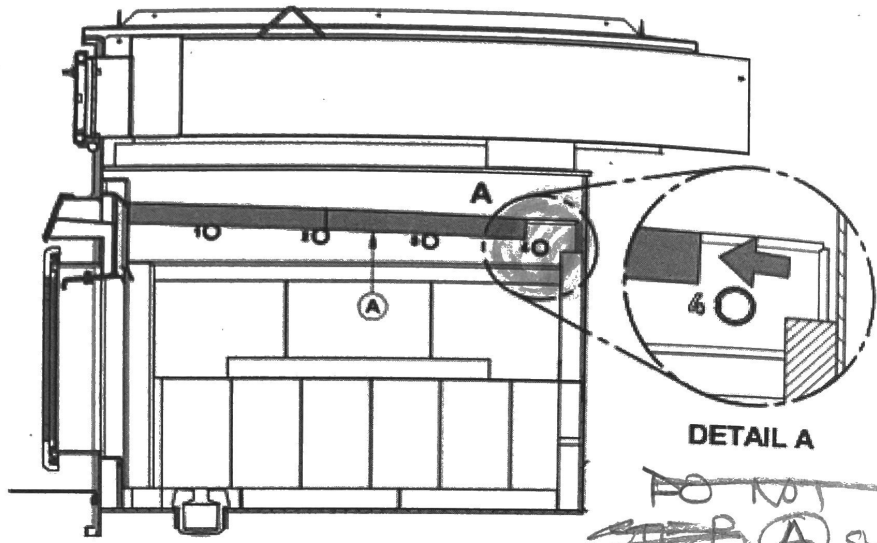

~~DO NOT DO THIS~~
~~STEP A SHOULD ALWAYS~~
BE SHD BACK.

3. Use the tool provided, clean the three exchanger pipes (see **Detail C**).

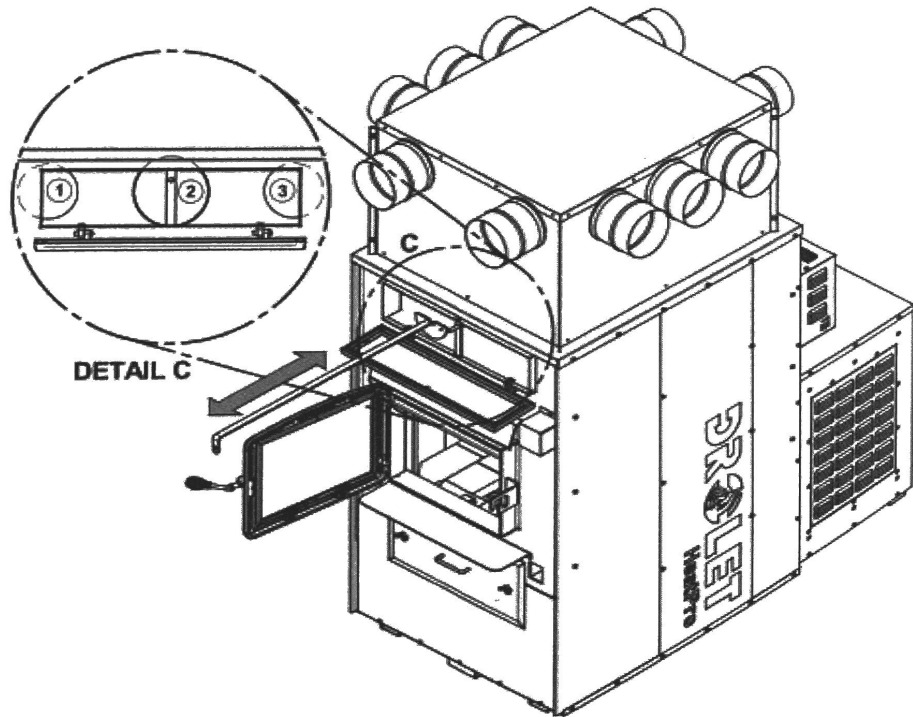

4. Dirt in the lateral exchangers (1 and 3) fall into the combustion chamber at the rear.

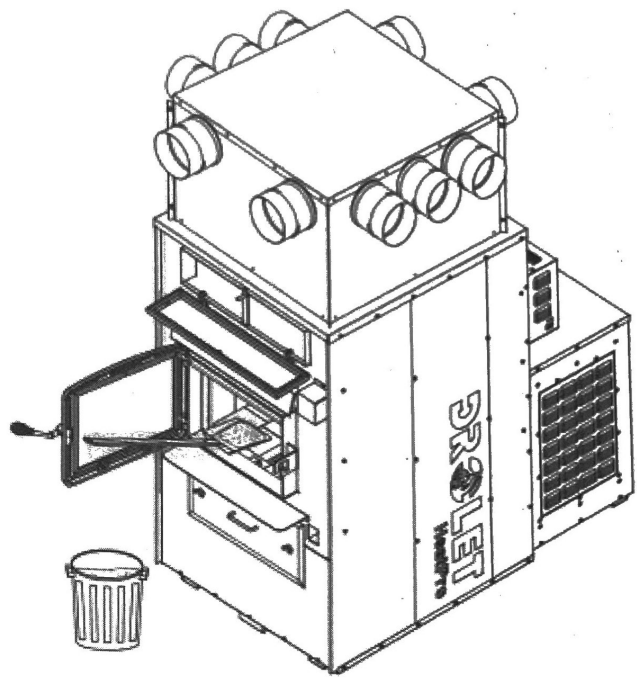
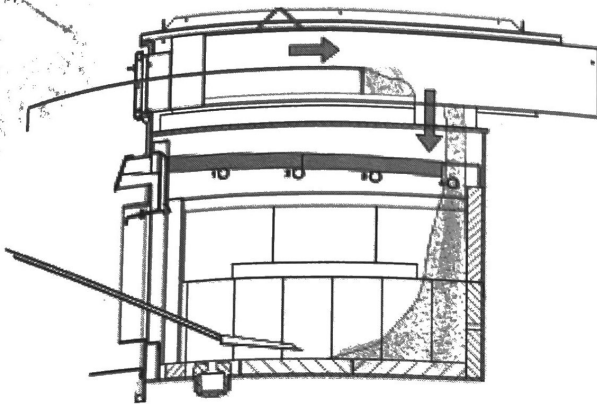

5. Dirt in the central exchanger (2) will be removed from the front or the rear of the furnace. If you remove dirt from the central exchange to the back of the furnace, remove the black pipe connector in order to dispose of the dirt.

6. Then, check that the baffle is clear of ash and reposition it in its original position towards the back of the combustion chamber.

NORMAL POS.
OF CEILING
BAFFLE PLATE

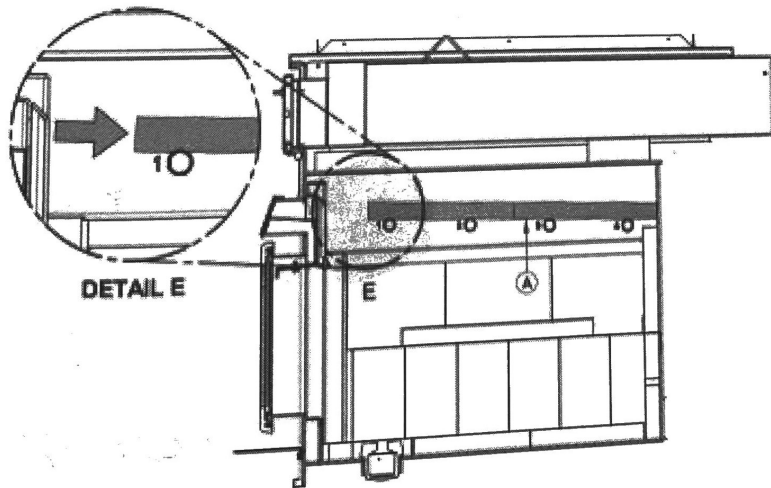

7. Close the exchanger access door and secure it using the washer (C) and wing nut (see Detail D).

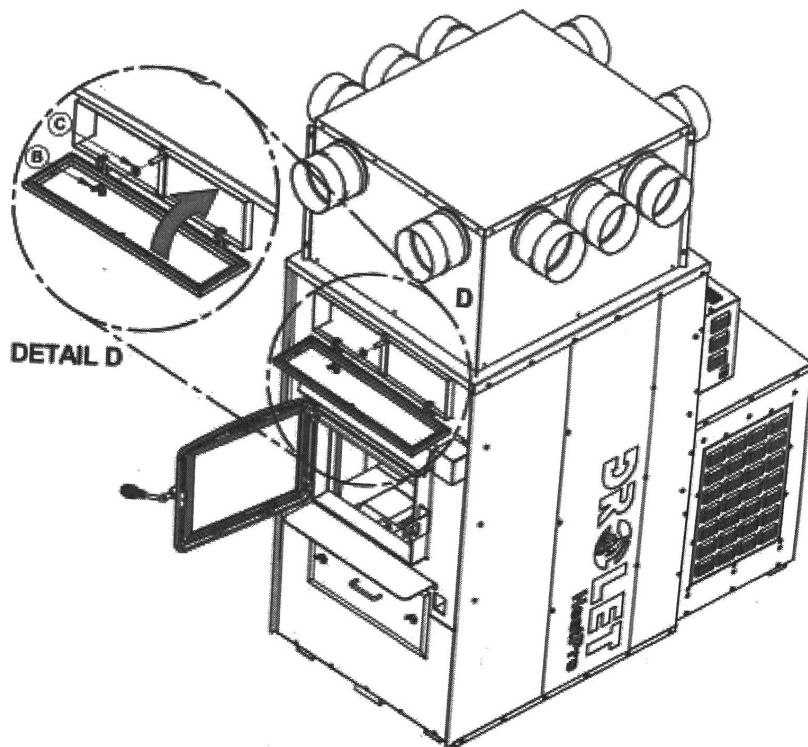

8. If you have performed maintenance from the back part of the furnace, reinstall the black pipe connector and secure it with three screws.

9.2 Chimney and chimney connector maintenance

9.2.1 Why chimney cleaning is necessary

Wood smoke can condense inside the chimney connector and chimney, forming a combustible deposit called creosote. If creosote is allowed to build up in the venting system it can ignite when a hot fire is burned in the furnace and a very hot fire can progress to the top of the chimney. Severe chimney fires can damage even the best chimneys. Smouldering, smoky fires can quickly cause a thick layer of creosote to form. When you avoid smouldering so the exhaust from the chimney is mostly clear, creosote builds up more slowly. Your new furnace has the right characteristics to help you to burn clean fires with little or no smoke, resulting in less creosote in the chimney.

9.2.2 How often should you clean the chimney? *FIRST YEAR, AT END OF SEASON (MARCH)*

It is not possible to predict how much or how quickly creosote will form in your chimney. It is important, therefore, to check the build-up in your chimney monthly when getting used to the new furnace until you determine the rate of creosote formation. Even if creosote forms slowly in your system, the chimney should be cleaned and inspected at least once each year.

Contact your local municipal or provincial fire authority for information on how to handle a chimney fire. Have a clearly understood plan to handle a chimney fire.

CLEAN HEAT EX. EVERY FRI. BEFORE LIGHTING.

CAUTION: IT IS RECOMMENDED TO CLEAN THE HEAT EXCHANGERS, FLUE PIPE AND CHIMNEY THOROUGHLY AT THE END OF THE HEATING SEASON IN ORDER TO PREVENT CORROSION DURING THE SUMMER MONTHS, CAUSED BY ACCUMULATED ASH!

9.2.3 Cleaning the chimney CLEAN IN MARCH AT CLOSE UP (NOT FLY)

Chimney cleaning can be a difficult and dangerous job. If you don't have experience cleaning chimneys, you might want to hire a professional chimney sweep to clean and inspect the system for the first time. After having seen the cleaning process, you can decide if it is a job you would like to take on.

The most common equipment used are fibreglass rods with threaded fittings and stiff plastic brushes. The brush is forced up and down inside the chimney flue to scrub off the creosote.

The chimney connector assembly should always be cleaned at the same time the chimney is cleaned.

CAUTION: Operation of your furnace without the baffle may cause unsafe and hazardous temperature conditions and will void the warranty. **NOTE:** Before installing the firebrick, check to ensure that none are broken or damaged in any way. If so, have the damaged ones replaced. Check the firebrick for damage at least annually and replace any broken or damaged ones with new ones. Inspection and cleaning of the chimney is facilitated by the removable baffle.

9.3 Smoke pipe inspection

- The smoke pipe must be inspected regularly during the heating season.
- The pipe must be examined carefully to detect any defect or damage.
- The pipe can be reassembled if no defect is detected and defective pipe must be replaced immediately.
- INSPECT FLUE PIPES, FLUE PIPE JOINTS, AND FLUE PIPE SEALS REGULARLY TO ENSURE THAT SMOKE AND FLUE GASES ARE NOT DRAWN INTO, AND CIRCULATED BY, THE AIR-CIRCULATION SYSTEM

9.4 Blower motor maintenance

Periodic cleaning of the blower housing and louvers as well as blower and blower blades using a vacuum cleaner is necessary in order not to affect performance and cause overheating of the latter.

10 Troubleshooting

PROBLEM	CAUSES	SOLUTIONS
Heating inefficient during the first combustions. Lack of draft.	Improper adjustment of the barometric damper (opened too wide). Chimney flue restriction (too long. 90° elbows)	Adjust the damper, minimize the smoke pipe length and use 45° elbows.
Furnace burns well, warm air plenum is very hot but there is not much heat coming out in the room.	Improper installation of the ducts, low static pressure, unbalanced system (too many warm air outlets and not enough fresh air return).	Rearrange the ducting to respect the minimum static pressure of 0.20 in. W.C. (50 Pa)
Furnace consumes a lot of wood.	Damper switch left always on. The thermostat which controls the damper is continuously activated or is too close to a source of cold air. Damper not properly adjusted. House not insulated enough. Ash plug and drawer are not tightly closed. Furnace too small for the surface to be heated. Unbalanced ventilation system, very little heat where the thermostat is located.	If manually controlled, install a wall thermostat. Relocate the thermostat. Rebalance the ventilation system in order to increase the air flow in the room where the thermostat is located.
A lot of creosote, moderate heat output.	Wet wood, lack of draft. Barometric damper not properly adjusted. Restriction in the furnace or chimney.	Use dry wood. Adjust the barometric damper. Clean the chimney, flue pipe and the furnace exchangers.
Furnace heats a lot but the warm air duct does not get hot.	Wet wood or low grade wood. No static pressure. Unbalanced ventilation system.	Use dry wood. Rearrange the ventilation system correctly.
Primary air inlet damper never opens.	Furnace is not plugged-in. or an electrical component is faulty.	Make sure the furnace is plugged-in a functional power outlet. Test and replace if necessary, control switch, thermostat, and damper motor.

10.1 Installation of secondary air tubes and baffle

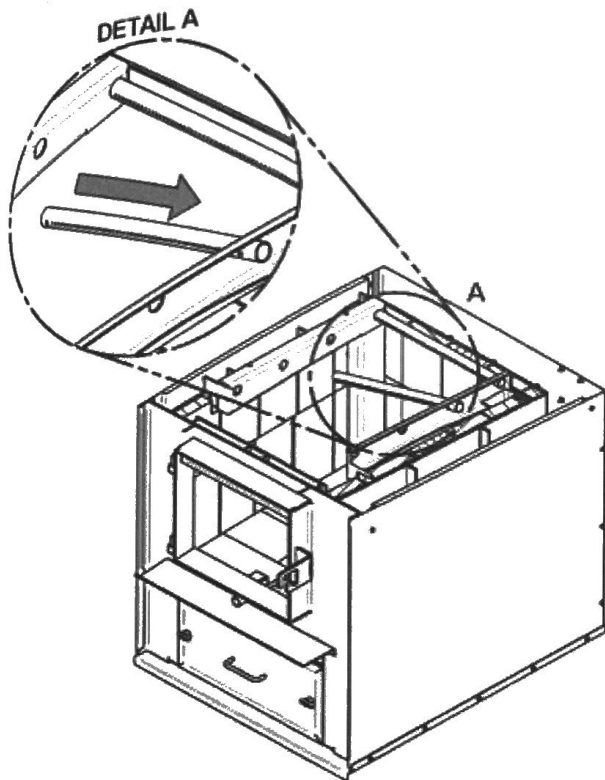

- 1- Starting with the rear tube, lean and insert the right end of the secondary air tube into the rear right channel hole. Then lift and insert the left end of the tube into the rear left channel.

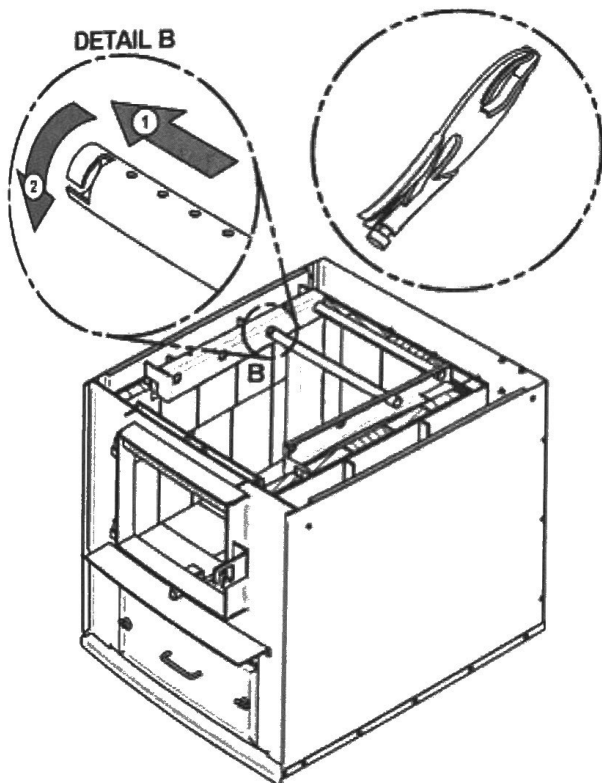

- 2- Align the notch in the left end of the tube with the key of the left air channel hole. Using a "Wise grip" hold the tube and lock it in place by turning the tube as shown in **Detail B**. Make sure the notch reaches the end of the key way.
- 3- Repeat **step 1** and **2** for the other secondary air tubes.
- 4- To remove the tubes use the above steps in reverse order.

Note that secondary air tubes (A) can be replaced without removing the baffle board (B).

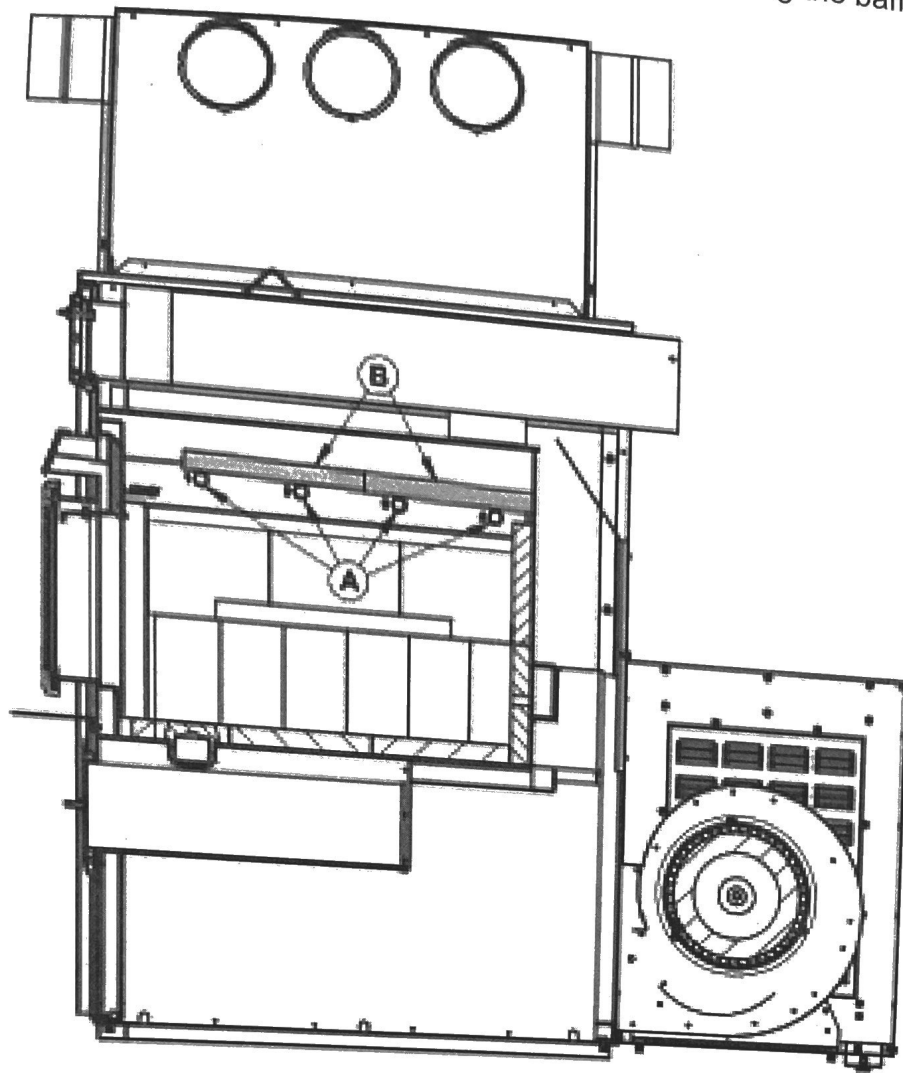

Important Notes:

The air tubes are identified for placement as follows:

Model	Type of tube
HEATPRO	Front ▶ 77 holes of 0.147" Middle front ▶ 77 holes of 0.161" Middle rear ▶ 77 holes of 0.180" Rear ▶ 77 holes of 0.194"

11 Exploded diagram and parts list

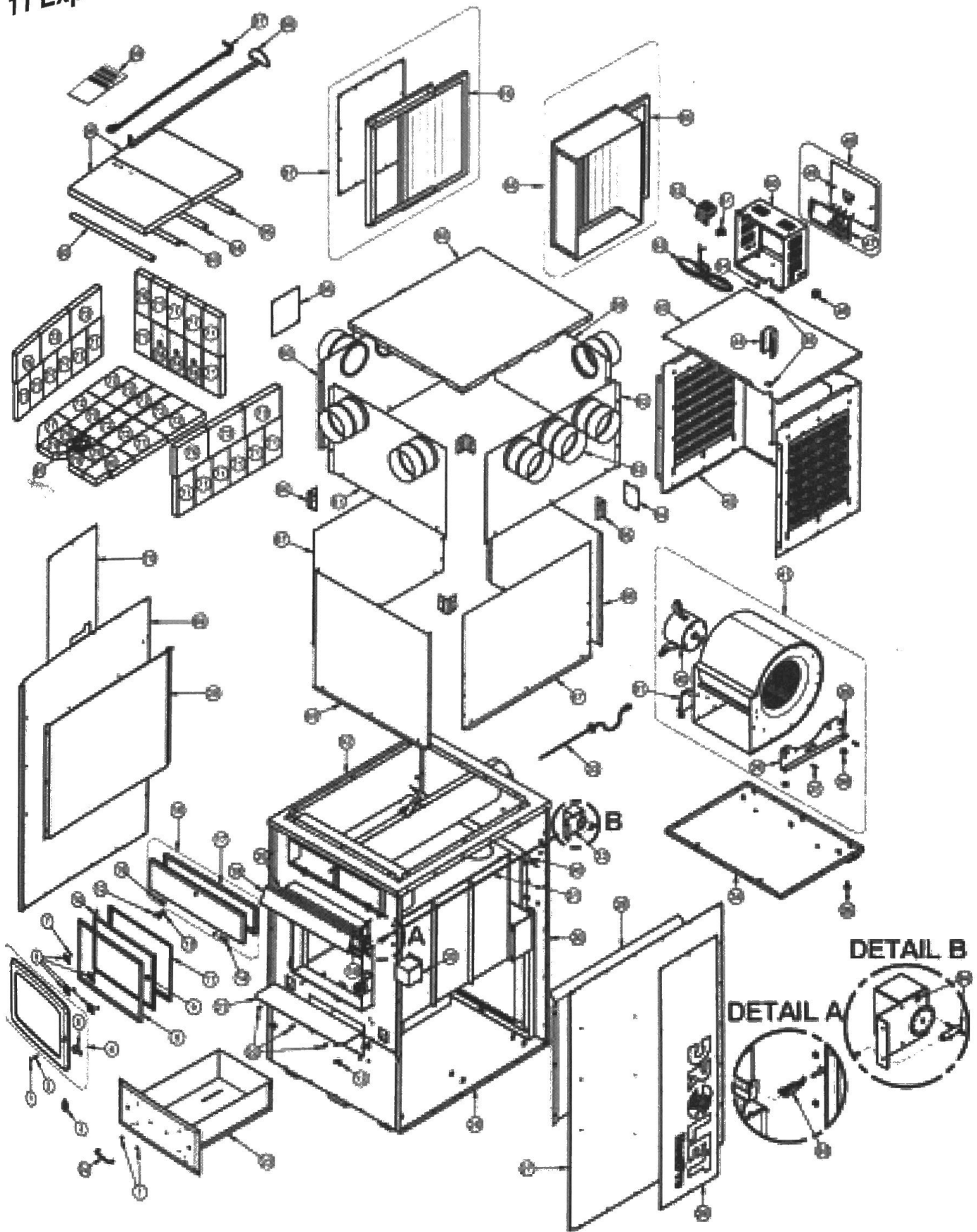

IMPORTANT: THIS IS DATED INFORMATION. When requesting service or replacement parts for your furnace, please provide the model and the serial number. We reserve the right to change parts due to technology upgrade or availability. Contact an authorized dealer to obtain any of these parts. Never use substitute materials. Use of non-approved parts can result in poor performance and safety hazards.

#	Item	Description	Qty
1	30100	BLACK HEX NUT 1/4 - 20	1
2	30128	SOCKET SET SCREW 1/4"-20 X 1 1/4"	1
3	30429	3/8" NICKEL COIL HANDLE	1
4	SE24025	CAST IRON DOOR WITH GASKET AND HANDLE	1
5	AC09151	REPLACEMENT HANDLE KIT	1
6	PL51351	GLASS RETAINER FRAME BRACKET	1
7	30124	SCREW #8 - 32 X 5/16" TRUSS QUADREX ZINC	4
8	AC06725	GLUE AND 3/4" X 7' WHITE DOOR GASKET KIT	6
9	SE56287	REPLACEMENT GLASS WITH GASKET 10 7/8" X 15 1/8"	1
10	AC06400	3/4" (FLAT) X 6' BLACK SELF-ADHESIVE GLASS GASKET	1
11	PL56285	GLASS RETAINER	1
12	30416	WING NUT 3/8"-16	2
13	30205	ZINC WASHER ID 13/32" X OD 13/16"	3
14	30168	HINGE PIN 5/16 DIA. X 1 1/4" LONG	1
15	30055	HINGE PIN RETAINING RING 5/16" ID X 0.512" OD	2
16	SE56800	HEAT EXCHANGER ACCESS DOOR ASSEMBLY	2
17	AC06000	SILICONE AND 1/2" X 8' BLACK DOOR GASKET KIT	1
18	SE56792	PRIMARY AIR DAMPER ASSEMBLY	1
19	PL56358	PRIMARY AIR DEFLECTOR	1
20	PL56793	DAMPER CONTROL GUARD	1
21	PL56780	ASH LIP	1
22	30060	THREAD-CUTTING SCREW 1/4-20 x 1/2" F HEX STEEL SLOT WASHER C102 ZINC	3
23	SE56781	ASH DRAWER	1
24	28061	CHROME ASH DRAWER HANDLE	1
25	21341	AIR CONTROL PLATE INSULATION	1
26	PL56765	AIR JACKET FLOOR	1
27	PL56769	RIGHT AIR JACKET PANEL	1
28	PL56772	RIGHT SIDE DECORATIVE PANNEL	1
29	PL56770	INTERNAL DEFLECTOR	2
30	PL56773	REAR AIR JACKET	1
31	30869	PRIMARY AIR CONTROL ROD	1
32	51000	HONEYWELL 24V DAMPER MOTOR	1
33	SE44096	100 OHM RTD PROBE 38" WIRE WITH CONNECTOR	1
34	PL56784	BLOWER BOX BASE	1
35	30536	LEVELING BOLT 1/4 - 20 x 1"	2
36	30336	RIGHT HOUSING SUPPORT FOR G10 BLOWER	1
37	30094	HEX SCREW WASHER HEAD 1/4-20 X 3/4" F ZINC TYPE	4

12 General information on HeatPro (DF03000)

12.1 Appliance performance ⁽¹⁾

Fuel type	Dry cordwood	
Recommended heating area ^[1]	1,500 to 3,500 ft ² (139 à 325 m ²)	
Firebox volume	4.9 ft ³ (0.139 m ³)	
Maximum burn time ^[1]	10 à 12 heures	
Maximum input capacity (dry cordwood) ⁽²⁾	421,000 BTU	
Overall heat output rate (min. to max.) ⁽³⁾	19,243 BTU/h to 67,069 BTU/h (5.6 kW to 19.6 kW)	
Average overall efficiency ⁽⁴⁾	78.9 % (HHV) ⁽⁵⁾	85.0 % (LHV) ⁽⁶⁾
Delivered heat output rate (min. to max.) ⁽⁷⁾	16,109 BTU/h to 54,578 BTU/h (4.7 kW to 16.0 kW)	
Average delivered efficiency ⁽⁸⁾	64.8 % (HHV) ⁽⁵⁾	70.2 % (LHV) ⁽⁶⁾
Optimum efficiency ⁽⁹⁾	85.8%	
Average particulate emissions rate ⁽¹⁰⁾⁽¹¹⁾	0.735 lb/mmBTU (0.316 g/MJ)	
Average CO ⁽¹²⁾	N/A	
Average electrical power consumption ⁽¹³⁾	360 Wh	

^[1] Recommended heating area and maximum burn time may vary subject to location in home, chimney draft, heat loss factors, climate, fuel type and other variables. The recommended heating area for a given appliance is defined by the manufacturer as its capacity to maintain a minimum acceptable temperature considering that the space configuration and the presence of heat distribution systems have a significant impact in making heat circulation optimum.

⁽¹⁾ Values are as measured per CSA B415.1-10, except for the recommended heating area, firebox volume, maximum burn time and maximum input capacity. Performances based on a fuel load prescribed by the standard at 10 lb/ft³ and with a moisture content between 18% and 28%.

⁽²⁾ Input value at 10lb/ft³ fuel loading density and dry energy value of 8,600BTU/lb.

⁽³⁾ Overall: Radiated and delivered heat together at 10lb/ft³ fuel loading density over one total burn cycle.

⁽⁴⁾ Efficiency based on delivered heat when allowing cycling from high to low burn to simulate thermostat demand.

⁽⁵⁾ Higher Heating Value of the fuel.

⁽⁶⁾ Lower Heating Value of the fuel.

⁽⁷⁾ Delivered: Remotely provided to other rooms through ducting at 10 lb/ft³ fuel loading density over one total burn cycle.

⁽⁸⁾ Efficiency based on radiated and delivered heat when allowing cycling from high to low burn to simulate thermostat demand.

⁽⁹⁾ Optimum overall efficiency at a specific burn rate (LHV).

⁽¹⁰⁾ Based on delivered heat output.

⁽¹¹⁾ This appliance is officially tested and certified by an independent agency.

⁽¹²⁾ Carbon Monoxide. Based on overall heat output at 10lb/ft³ fuel loading density.

⁽¹³⁾ Unless stated otherwise, measures were taken directly at the main power source and include all electrical components present in the appliance.

12.2 General Features

Maximum log length	24" (610 mm) north-south**
Diameter of the flue collar	6 in. (152 mm)
Recommended connector pipe diameter	6 in. (152 mm)
Recommended chimney diameter	6 in. (152 mm)
Required type of chimney	Listed to ULC S629 or UL 103 HT (2100 °F)
Baffle material	C-Cast
Alcove installation	Not approved
Mobile home installation [‡]	Not approved
Appliance weight (without options)	719 lb (326 kg)
Shipping weight	819 lb (371 kg)
Blower	Included
Filter	Non-Included: 15 in x 20 in x 1 in

** East-west: through the door you see the longitudinal sides of the logs; north-south: through the door you see the tips of the logs.

[‡] Mobile home (Canada) or manufactured home (USA): The US department of Housing and Urban Development describes "manufactured homes" better known as "mobile homes" as followed; buildings built on fixed wheels and those transported on temporary wheels/axles and set on a permanent foundation. In Canada, a mobile home is a dwelling for which the manufacture and assembly of each component is completed or substantially completed prior to being moved to a site for installation on a foundation and connection to service facilities and which conforms to the CAN/CSA-Z240 MH standard

12.2.1 Technical data HeatPro

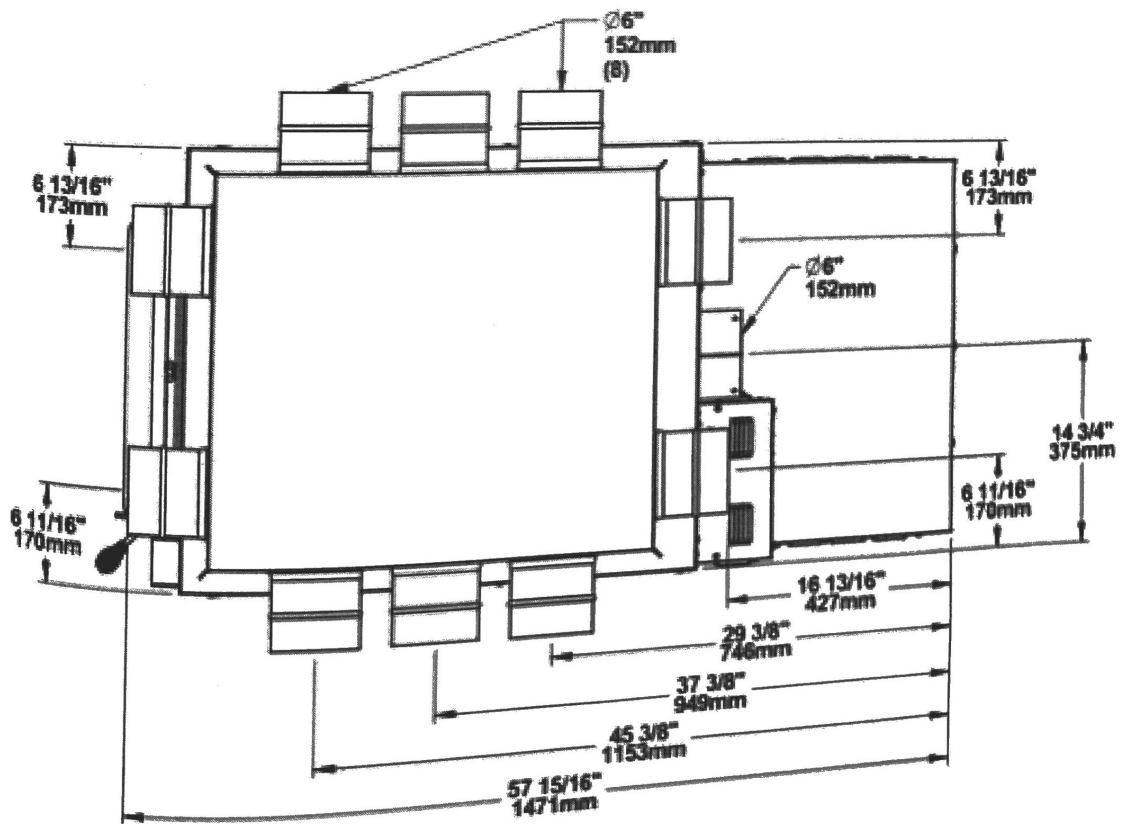
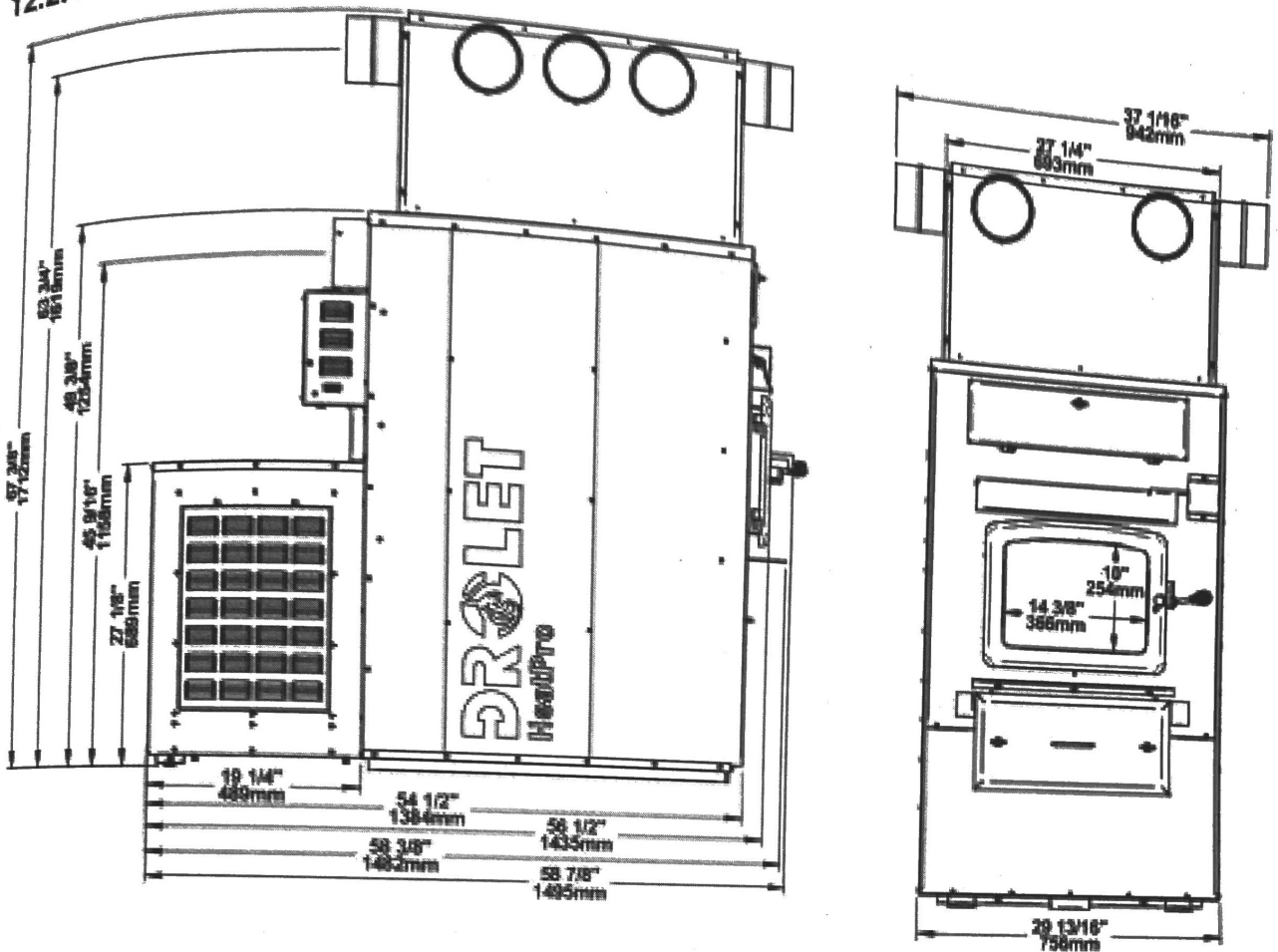

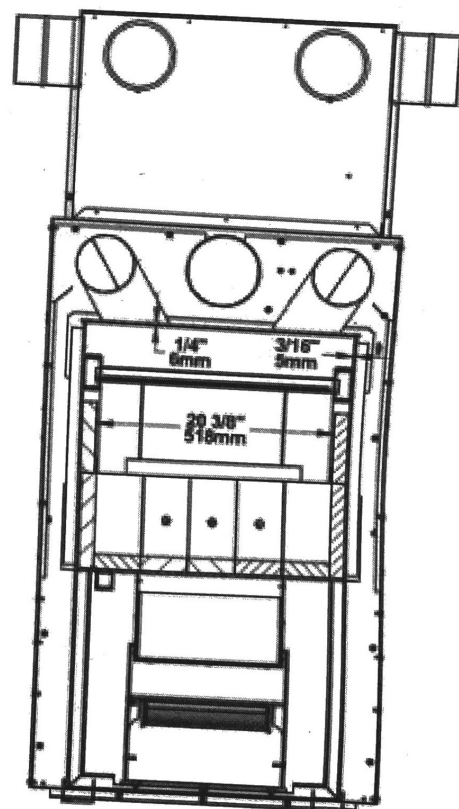
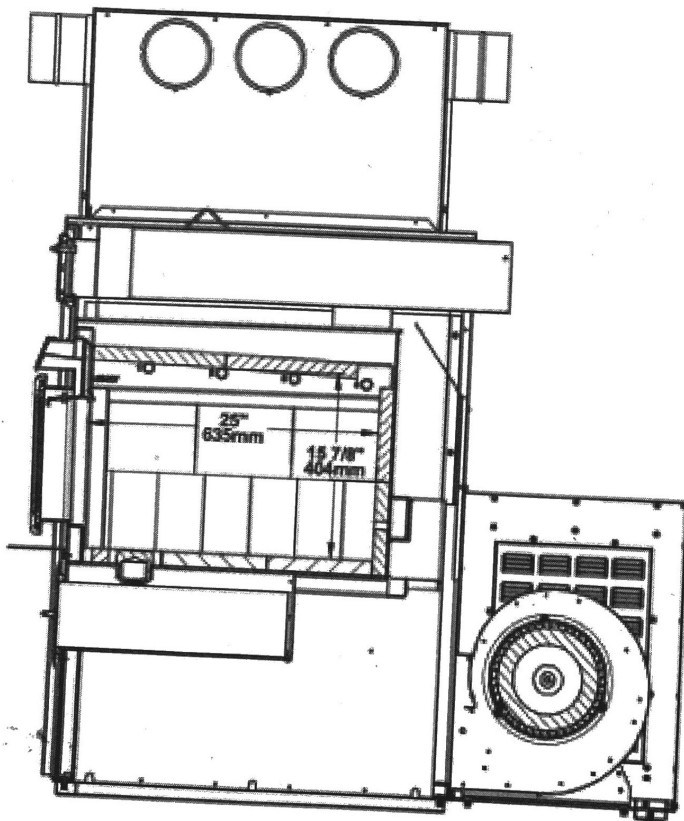
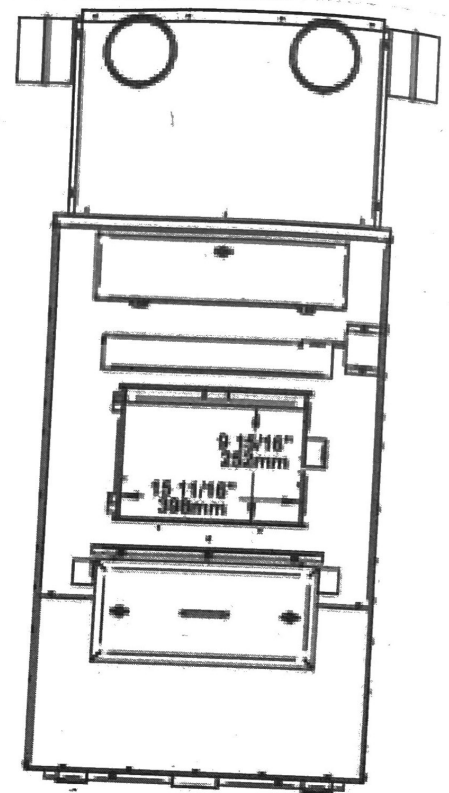
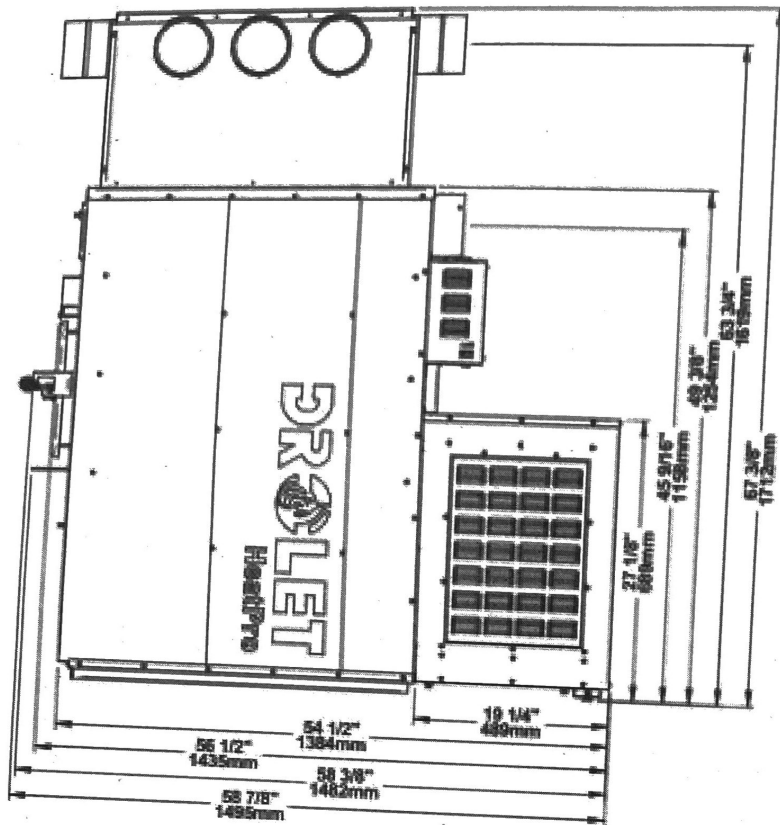

12.3 The benefits of low emissions and high efficiency

The low smoke emissions produced by the special features inside the Brand Model firebox mean that your household will release up to 90 percent less smoke into the outside environment than if you used an older conventional wood furnace. But there is more to the emission control technologies than protecting the environment.

The smoke released from wood when it is heated contains about half of the energy content of the fuel. By burning the wood completely, your furnace releases all the heat energy from the wood instead of wasting it as smoke up the chimney. Also, the features inside the firebox allow you to reduce the air supply to control heat output, while maintaining clean and efficient flaming combustion, which boosts the efficient delivery of heat to your home.

The emission control and advanced combustion features of your furnace can only work properly if your fuel is in the correct moisture content range of 15 to 20 percent. See **PART 2 – OPERATION, MAINTENANCE AND TROUBLESHOOTING** for suggestions on preparing fuel wood and judging its moisture.

12.4 The SBI commitment to you and the environment

The SBI team is committed to protecting the environment, so we do everything we can to use only materials in our products that will have no lasting negative impact on the environment.

12.4.1 What is your new furnace made of?

The body of your furnace, which is most of its weight, is carbon steel. Should it ever become necessary many years in the future, almost the entire furnace can be recycled into new products, thus eliminating the need to mine new materials.

The paint coat on your furnace is very thin. Its VOC content (Volatile Organic Components) is very low. VOCs can be responsible for smog, so all the paint used during the manufacturing process meets the latest air quality requirements with regards to VOC reduction or elimination.

The air tubes are stainless steel, which can also be recycled.

The C-Cast baffle is made of an aluminosilicate fibre material that is compressed with a binder to form a rigid board. C-Cast can withstand temperatures above 2,000 °F. It is not considered hazardous waste. Disposal at a landfill is recommended.

Lightweight firebrick is made of pumice and cement. Pumice is in fact volcanic rock, a naturally green product found in the Northwest United States. Disposal at a landfill is recommended.

The door and glass gaskets are fibreglass which is spun from melted sand. Black gaskets have been dipped into a solvent-free solution. Disposal at a landfill is recommended.

The door glass is a 5 mm thick ceramic material that contains no toxic chemicals. It is basically made of raw earth materials such as sand and quartz that are combined in such a way to form a glass at high temperatures. Ceramic glass will not re-melt in the same way as normal glass, so it should not be recycled with your regular household products. Disposal at a landfill is recommended.

13 Safety information

13.1 Cautions and warnings

- A CARBON MONOXIDE (CO) DETECTOR/ALARM IS REQUIRED IN THE ROOM IN WHICH THE FURNACE IS INSTALLED.
- HOT WHILE IN OPERATION, KEEP CHILDREN, CLOTHING AND FURNITURE AWAY. CONTACT MAY CAUSE SKIN BURNS. GLOVES MAY BE NEEDED FOR FURNACE OPERATION.
- USING A FURNACE WITH CRACKED OR BROKEN COMPONENTS, SUCH AS GLASS OR FIREBRICKS OR BAFFLES MAY PRODUCE AN UNSAFE CONDITION AND MAY DAMAGE THE FURNACE.
- OPEN THE AIR CONTROL FULLY BEFORE OPENING FIRING DOOR.
- OPERATE ONLY WITH DOOR FULLY CLOSED. IF DOOR IS LEFT PARTLY OPEN, GAS AND FLAME MAY BE DRAWN OUT OF THE OPENING, CREATING RISKS FROM BOTH FIRE AND SMOKE.
- WARNING: AN EXCESSIVE DRAFT MAY CAUSE OVERHEATING AND MAKE THE CONTROL OF THE FIRE DIFFICULT.
- THIS FURNACE IS NOT DESIGNED TO BE USED WITH THE DOOR OPEN. THE DOOR MAY BE OPEN ONLY DURING LIGHTING PROCEDURES OR RELOADING. DO NOT LEAVE THE FURNACE UNATTENDED WHEN THE DOOR IS SLIGHTLY OPENED DURING IGNITION. ALWAYS CLOSE THE DOOR AFTER IGNITION.
- NEVER USE GASOLINE, GASOLINE-TYPE LANTERN FUEL (NAPHTHA), FUEL OIL, MOTOR OIL, KEROSENE, CHARCOAL LIGHTER FLUID, OR SIMILAR LIQUIDS OR AEROSOLS TO START OR 'FRESHEN UP' A FIRE IN THIS FURNACE. KEEP ALL SUCH LIQUIDS OR AEROSOLS WELL AWAY FROM THE FURNACE WHILE IT IS IN USE.
- DO NOT STORE FUEL WITHIN HEATER MINIMUM INSTALLATION CLEARANCES.
- BURN ONLY SEASONED NATURAL FIREWOOD.
- DO NOT BURN:
 - GARBAGE OF ANY KIND,
 - COAL OR CHARCOAL,
 - TREATED, PAINTED OR COATED WOOD,
 - PLYWOOD OR PARTICLE BOARD,
 - FINE PAPER, COLORED PAPER OR CARDBOARD,
 - ALL MANUFACTURED LOGS,
 - SALT WATER DRIFTWOOD OR
 - RAILROAD TIES.
- DO NOT USE LIQUIDS SUCH AS KEROSENE OR DIESEL FUEL TO START A FIRE.

- DO NOT ELEVATE THE FIRE BY USING A GRATE IN THIS FURNACE.
- DO NOT INSTALL AN AUTOMATIC FEEDER ON THIS FURNACE.
- DO NOT INSTALL A MANUAL DAMPER ON THIS FURNACE.
- THIS APPLIANCE SHOULD BE MAINTAINED AND OPERATED AT ALL TIMES IN ACCORDANCE WITH THESE INSTRUCTIONS.
- DO NOT USE FLAMMABLE LIQUIDS SUCH AS GASOLINE, NAPHTHA, FUEL OIL, MOTOR OIL, OR AEROSOLS TO START OR REKINDLE THE FIRE.
- WARNING: IT IS IMPORTANT THAT THE FIRING DOOR, THE ASH DRAWER AND THE ASHPLUG BE KEPT CLOSED WHILE THE APPLIANCE IS IN USE. MAINTAIN ALL GASKETS, IF ANY, IN GOOD CONDITION; IN CASE OF DETERIORATION, CONTACT YOUR DEALER FOR A GENUINE REPLACEMENT GASKET.
- THE INFORMATION GIVEN ON THE CERTIFICATION LABEL AFFIXED TO THE APPLIANCE ALWAYS OVERRIDES THE INFORMATION PUBLISHED, IN ANY OTHER MEDIA (OWNER'S MANUAL, CATALOGUES, FLYERS, MAGAZINES AND/OR WEB SITES).
- MIXING OF CHIMNEY COMPONENTS FROM DIFFERENT SOURCES OR MODIFYING FURNACE COMPONENTS MAY RESULT IN HAZARDOUS CONDITIONS. WHERE ANY SUCH CHANGES ARE PLANNED, FURNACE BUILDER INTERNATIONAL INC. SHOULD BE CONTACTED IN ADVANCE.
- ANY MODIFICATION OF THE APPLIANCE THAT HAS NOT BEEN APPROVED IN WRITING BY THE TESTING AUTHORITY VIOLATES CSA B365 (CANADA), AND NFPA 90B (USA).
- IF REQUIRED, A SUPPLY OF COMBUSTION AIR SHALL BE PROVIDED TO THE ROOM OR SPACE.
- DO NOT STORE NEAR WOOD FURNACE. RESPECT THE PRESCRIBED CLEARANCE BETWEEN COMBUSTIBLES AND HEAT.
- DO NOT CONNECT THIS UNIT TO A CHIMNEY FLUE SERVING ANOTHER APPLIANCE.
- DO NOT INSTALL IN A MOBILE HOME
- DO NOT INSTALL IN ALCOVE
- THIS APPLIANCE MUST BE INSTALLED IN ACCORDANCE WITH THE INSTRUCTIONS ON THE CERTIFICATION LABEL APPLIED ON THE UNIT.
- NO PART OF THE FURNACE OR FLUE PIPE MAY BE LOCATED CLOSER TO COMBUSTIBLES THAN THE MINIMUM CLEARANCE FIGURES GIVEN.

WARNING: Respect the local codes (when in doubt, consult your local dealer).

13.2 Smoke detector

We highly recommend the use of a smoke detector. It must be installed at least 15 feet (4.57 m) from the appliance in order to prevent undue triggering of the detector when reloading.

13.3 Chimney fire

A Chimney fire will happen when the flame from an uncontrollable fire ignites the soot and creosote deposits in a neglected venting system. It will often happen when burning cardboard, branches or small dry pieces of wood. The first signs of a chimney fire are:

1. A rumble.
2. Smoke pipe becomes extremely hot.
3. Sparks or even flames shoot out of the chimney

In the event of a chimney fire, first call your local fire department and water the roof in the vicinity of the chimney.

Make sure that the furnace door and the air intake damper are closed (if need be, lower the thermostat setting and CLOSE the barometric draft damper manually if one is installed). Close also the switch on the control box.

In the event of uncontrollable fire (caused by wrongful operation or excessive chimney draft), follow the same procedure as in a chimney fire but you must then OPEN the barometric draft damper manually if one is installed.

DROLET LIMITED LIFETIME WARRANTY

The warranty of the manufacturer extends only to the original retail purchaser and is not transferable. This warranty covers brand new products only, which have not been altered, modified nor repaired since shipment from factory. Proof of purchase (dated bill of sale), model name and serial number must be supplied when making any warranty claim to your DROLET dealer.

This warranty applies to normal residential use only. Damages caused by misuse, abuse, improper installation, lack of maintenance, over firing, negligence or accident during transportation, power failures, downdrafts, venting problems or under-estimated heating area are not covered by this warranty. The recommended heated area for a given appliance is defined by the manufacturer as its capacity to maintain a minimum acceptable temperature in the designated area in case of a power failure.

This warranty does not cover any scratch, corrosion, distortion, or discoloration. Any defect or damage caused by the use of unauthorized or other than original parts voids this warranty. An authorized qualified technician must perform the installation in accordance with the instructions supplied with this product and all local and national building codes. Any service call related to an improper installation is not covered by this warranty.

The manufacturer may require that defective products be returned or that digital pictures be provided to support the claim. Returned products are to be shipped prepaid to the manufacturer for investigation. Transportation fees to ship the product back to the purchaser will be paid by the manufacturer. Repair work covered by the warranty, executed at the purchaser's domicile by an authorized qualified technician requires the prior approval of the manufacturer. All parts and labour costs covered by this warranty are limited according to the table below.

The manufacturer, at its discretion, may decide to repair or replace any part or unit after inspection and investigation of the defect. The manufacturer may, at its discretion, fully discharge all obligations with respect to this warranty by refunding the wholesale price of any warranted but defective parts. The manufacturer shall, in no event, be responsible for any uncommon, indirect, consequential damages of any nature, which are in excess of the original purchase price of the product. A one-time replacement limit applies to all parts benefiting from lifetime coverage. This warranty applies to products purchased after March 1st, 2015.

DESCRIPTION	WARRANTY APPLICATION*	
	PARTS	LABOUR
Combustion chamber (welds only) and cast iron door frame.	Lifetime	3 years
Surrounds, heat shields, ash drawer, steel legs, pedestal, trims (aluminum extrusions), plating (defective manufacture**), and convector air-mate.	5 years	3 years
Removable stainless steel combustion chamber components, secondary air tubes**, deflectors, and supports.	5 years	N/A
Glass retainers, handle assembly, and air control mechanism.	3 years	1 year
Carbon steel combustion chamber components, vermiculite baffle**, and C-Cast baffle**.	2 years	N/A
Standard blower, heat sensors, switches, rheostat, wiring, and other controls.	1 year	1 year
Optional blower, paint (peeling**), ceramic glass (thermal breakage only**), ceramic fibre blankets, gaskets, insulation, and other options.	1 year	N/A
Firebricks.	N/A	N/A
All parts replaced under the warranty.	90 days	N/A

**Subject to limitations above. **Picture required.*

Labour cost and repair work to the account of the manufacturer are based on a predetermined rate schedule and must not exceed the wholesale price of the replacement part.

Shall your unit or a components be defective, contact immediately your **DROLET** dealer. To accelerate processing of your warranty claim, make sure to have on hand the following information when calling:

- Your name, address and telephone number;
- Bill of sale and dealer's name;
- Installation configuration;
- Serial number and model name as indicated on the nameplate fixed to the back of your unit;
- Nature of the defect and any relevant information.

Before shipping your unit or defective component to our plant, you must obtain an Authorization Number from your DROLET dealer. Any merchandise shipped to our plant without authorization will be refused automatically and returned to sender.