

Contents

English	01
Español	25
Français	49
Italiano	73
Deutsch	97
日本語	121

ELEGOO

●CANVAS for Centauri Carbon

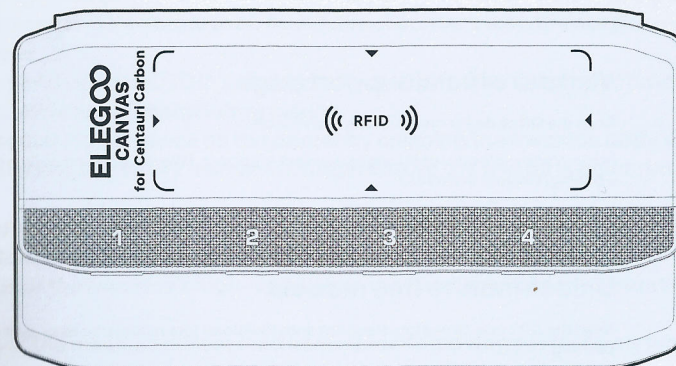

User Manual

■ Please refer to the included USB drive for a setup and installation instructional video.

Thank you for choosing the ELEGOO Product!

Upon receiving your product, please check that the device is in good condition and all accessories are included. If you encounter any issues during installation, operation, or maintenance, please contact the ELEGOO after-sales team through the official channels below for professional support:



Visit our official support page

Scan the QR code for one-on-one assistance.

<https://www.elegoo.com/pages/contact-support>. (We recommend copying the link and opening it in your browser.)

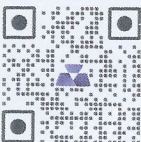

Unlock infinite free models

Scan the QR code to explore Nexprint and download free models for easy, one-click printing.

<https://www.nexprint.com/?got=IN>

(Note: To ensure optimal performance, each ELEGOO product undergoes rigorous printing tests before shipping. Minor surface scratches may be visible upon delivery; this is normal and will not affect functionality.)

ELEGOO

Important Notes

- Do not place the printer in highly vibrating or unstable environment, as machine vibrations can affect print quality.
- Do not touch the nozzle or heated bed while the printer is in operation to avoid burns and personal injury from high temperatures.
- After printing, promptly utilize the residual heat in the nozzle to effectively clean the filament residue using a suitable tool. Avoid direct contact with the nozzle to prevent potential burns.
- We recommend using ELEGOO's slicing software to ensure the proper functioning of the machine and achieve optimal printing results.
- Perform regular maintenance on the printer by cleaning the machine body with a dry cloth to remove dust and any sticky filament residue. Ensure the printer is powered off before cleaning.
- Regularly inspect and clean the printer's cooling fans to prevent dust buildup, ensuring optimal performance and extended service life.
- Be cautious of the machine's high-speed moving parts to avoid any potential pinch hazards.
- The Z-axis of the machine utilizes lead screws for its moving parts. Apply lubricating oil as needed to ensure smooth movement.
- Children must be supervised by adults when using the machine to avoid personal injury.
- In case of an emergency, directly turn off the power.
- Ensure the machine is properly grounded for safe operation. Failure to properly ground or neglecting to ground the machine can increase the risk of electrical leakage.
- If the machine is not in use for an extended period, please turn off the power and unplug the power cord.

Component Introduction

Filament Outlet

Filament Inlet

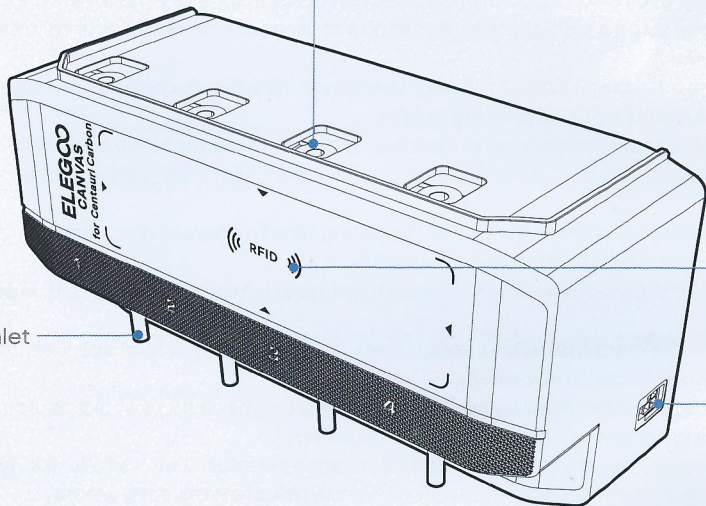

RFID Reader

4-Pin Port

Included Accessories

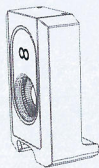

Model Cooling Fan Assembly

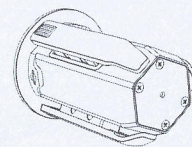

Spool Holder Module
(2 Left, 2 Right)

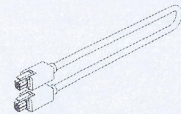

4-Pin Cable



Filament Hub

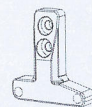

Filament Hub Bracket

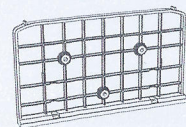

CANVAS Mounting Bracket



Spool Holder Mounting Assembly (x2)

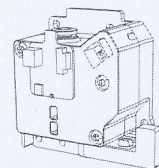

Gearbox/Filament
Cutter Assembly

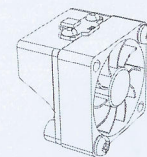

Heat Break Fan Assembly

Multicolor Printing Upgrade

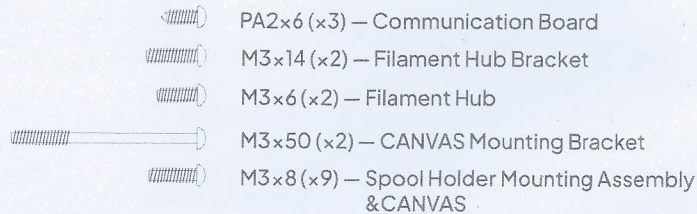
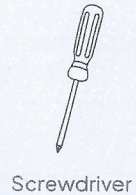
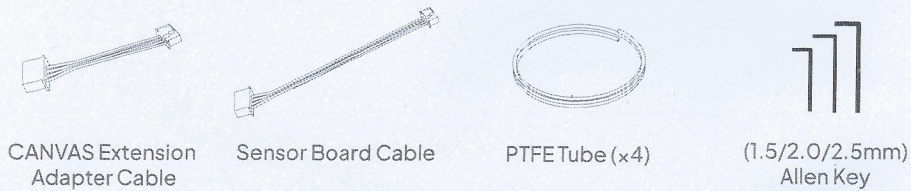
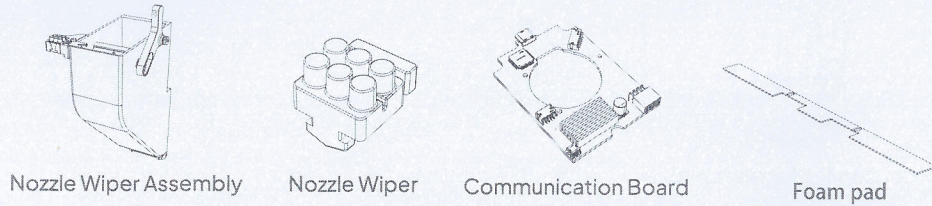

Scan the QR code to watch the video tutorial

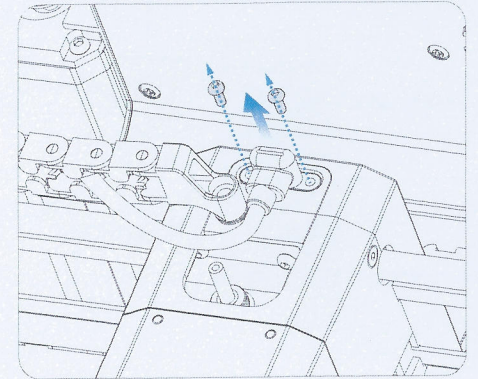

1. Remove the mounting screws and disconnect the extruder communication cable.

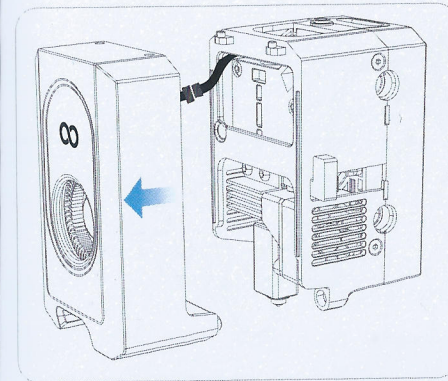

2. Detach the model cooling fan assembly and unplug the fan cable.

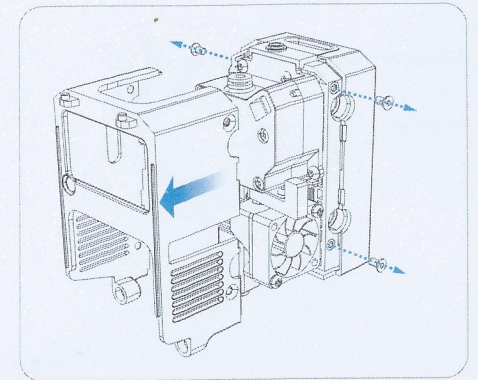

3. Unscrew the four screws on both sides of the extruder cover and remove the cover.

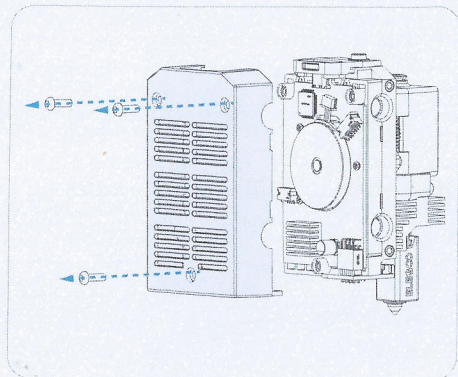

4. Remove the three mounting screws and detach the rear cover.

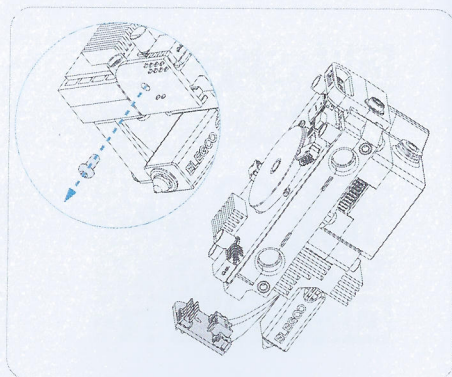

5. Remove the screw securing the printed circuit board assembly (PCBA) and take off the PCBA.

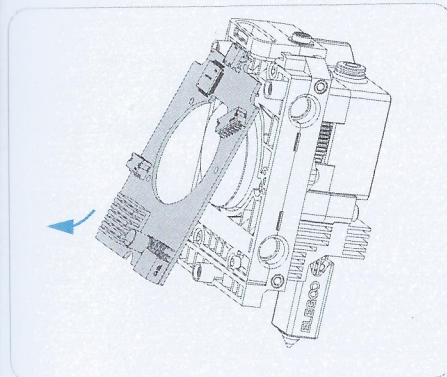

8. Tilt the extruder communication board downward and slide it out.

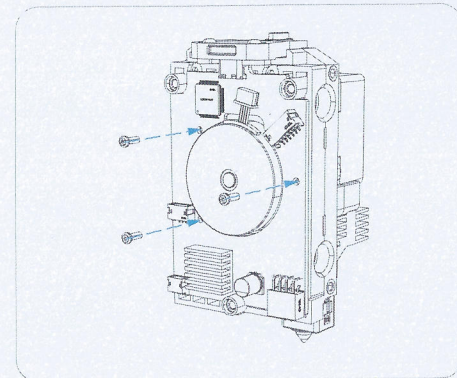

9. Install the new extruder communication board and secure it with three screws.

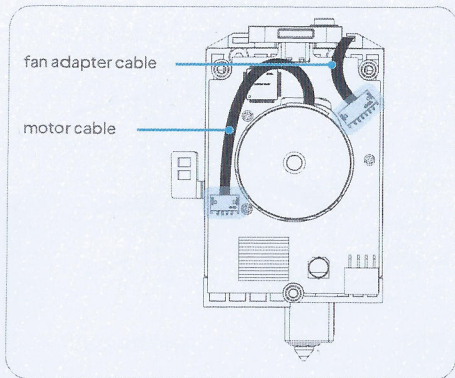

6. Disconnect the fan adapter cable and motor cable.

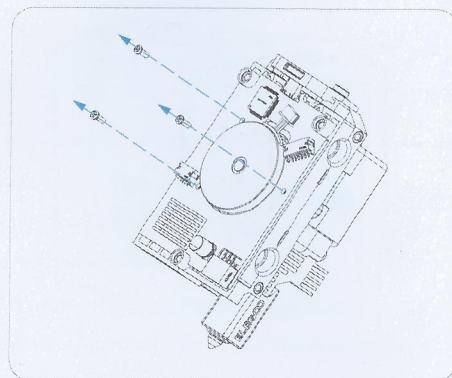

7. Remove the screws securing the communication board.

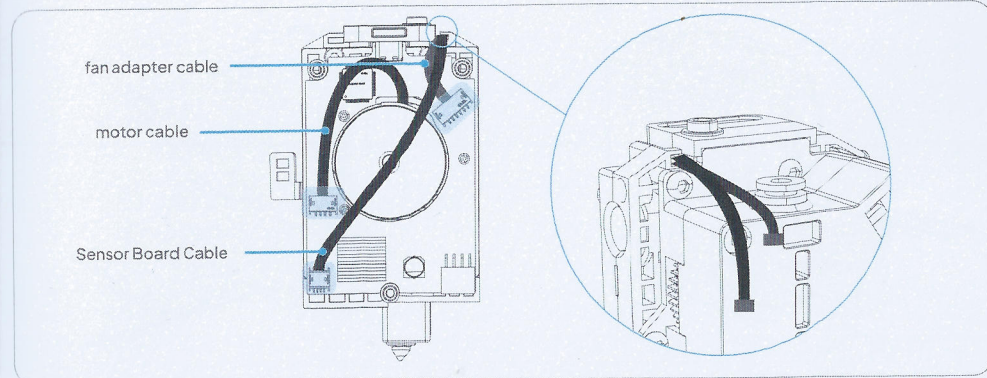

10. Connect the fan adapter cable, motor cable, and sensor board cable to the extruder communication board as shown.

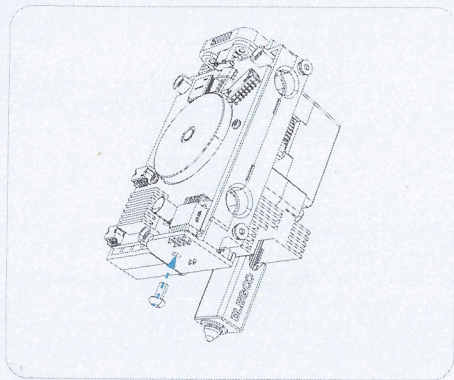

11. Reinstall the PCBA and secure it with the screw.

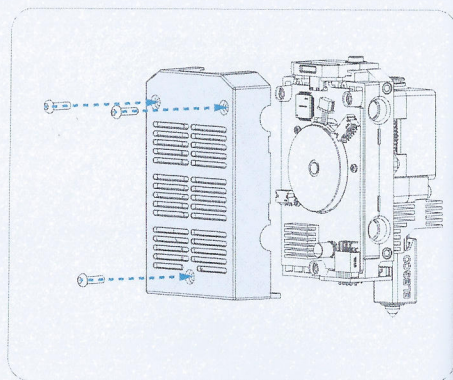

12. Reattach the rear cover and secure it with three screws.

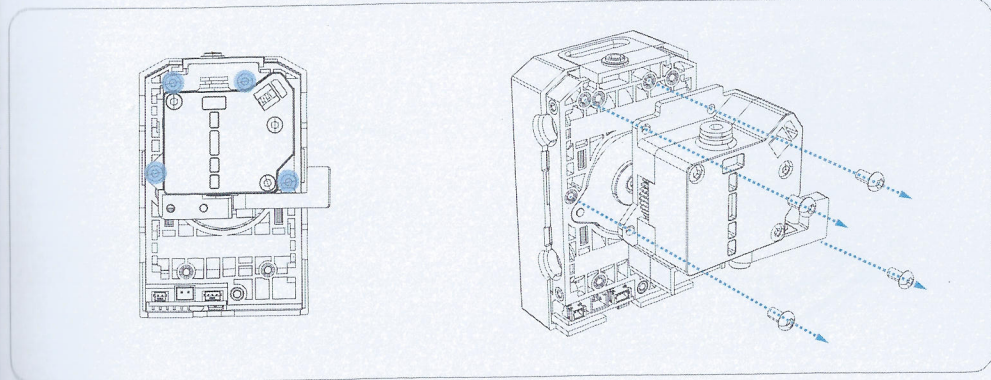

15. Remove the old gearbox and filament cutter assembly.

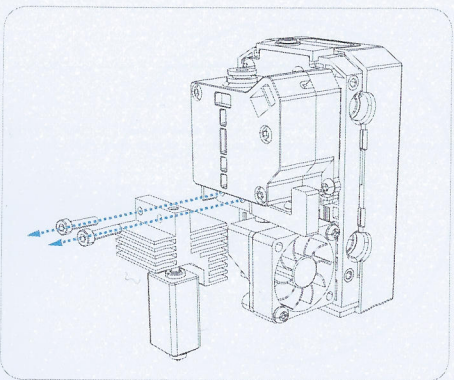

13. Remove the hotend.

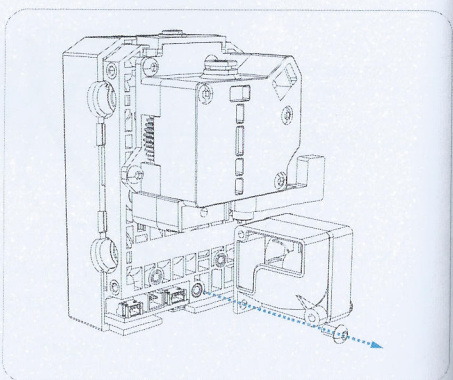

14. Remove the old heat break fan assembly.

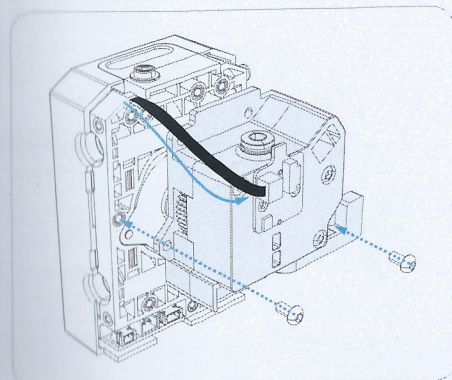

16. Install the new gearbox and filament cutter assembly, and connect the sensor board cable.

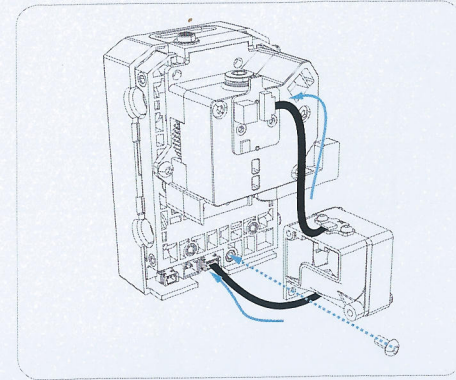

17. Install the new heat break fan assembly, and connect the fan cable.

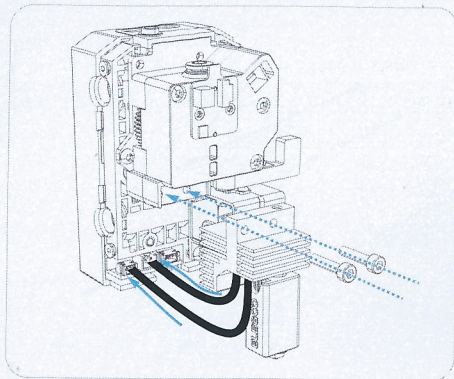

18. Reinstall the hotend.

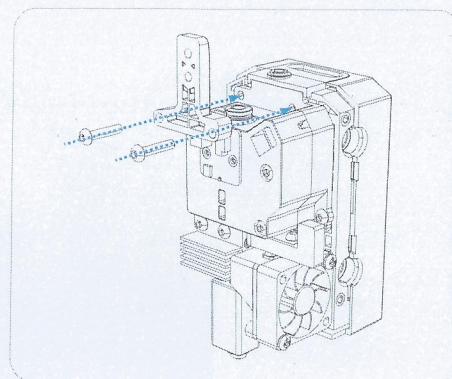

19. Use two M3x14 screws to secure the filament hub bracket and gearbox together.

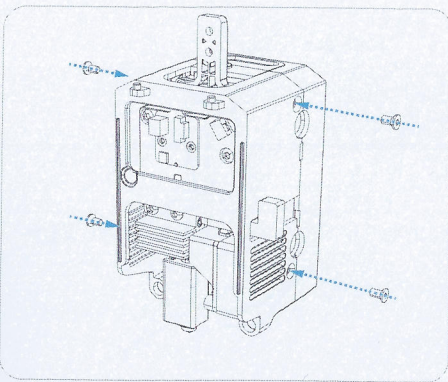

20. Reinstall the extruder cover.

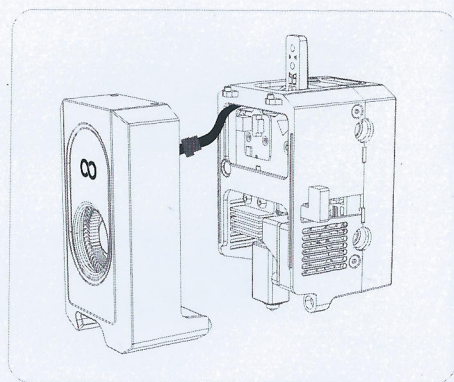

21. Install the new model cooling fan assembly.

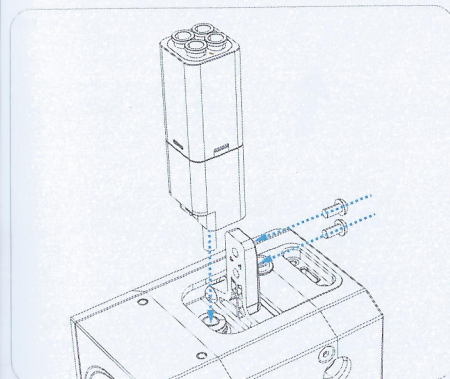

22. Insert the metal tube of the filament hub into the pneumatic fitting on the top of the printhead, and secure it to the filament hub bracket with two M3x6 screws.

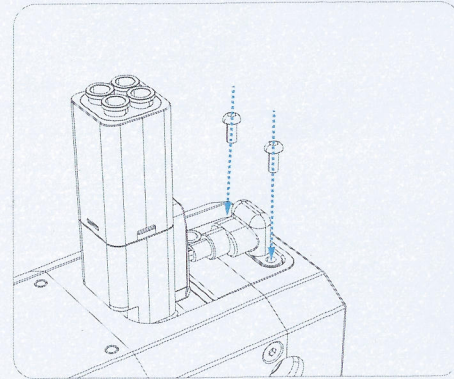

23. Install and secure the communication cable with screws.

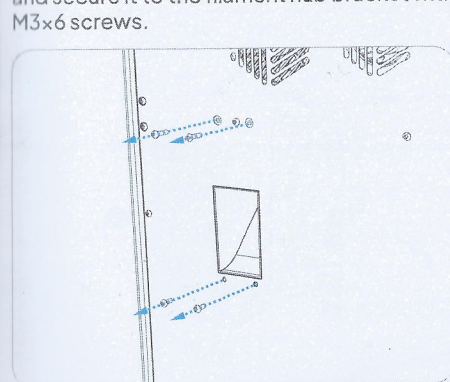

24. Loosen the four screws to remove the old nozzle wiper assembly.

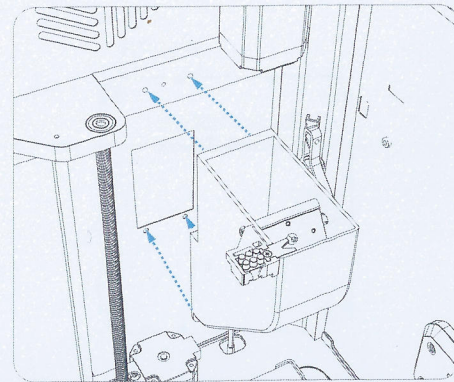

25. Install the new nozzle wiper assembly.

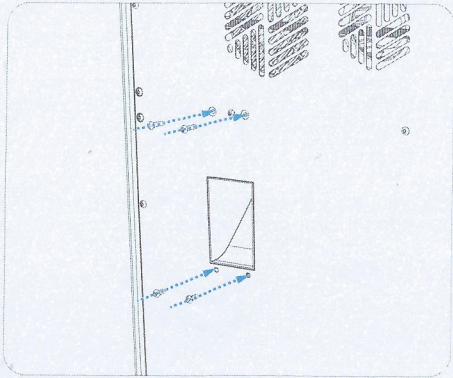

26. Secure the nozzle wiper assembly with screws to complete installation.

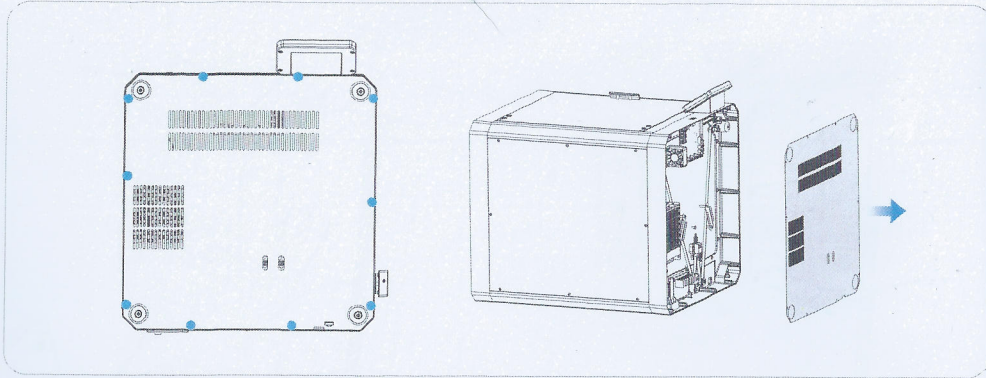

27. Unscrew the ten screws securing the bottom plate and remove the bottom plate.

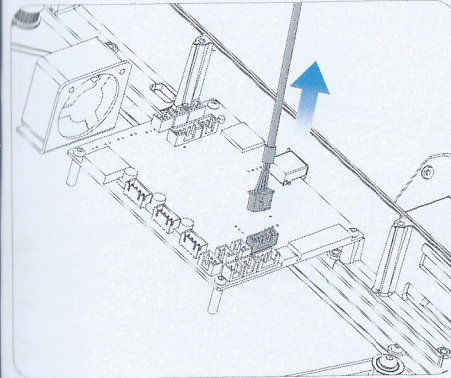

28. Disconnect the CANVAS cable.

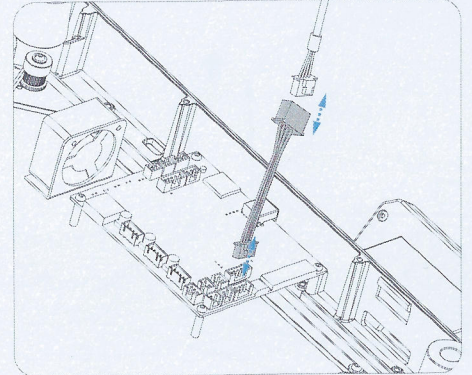

29. Connect the CANVAS extension adapter cable.

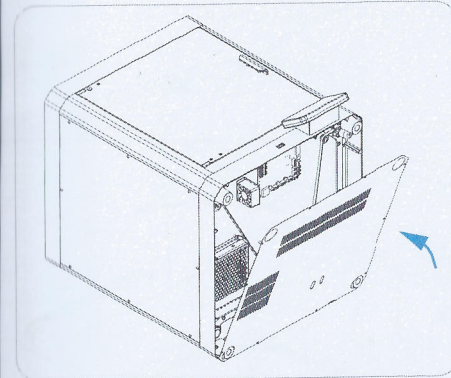

30. Reinstall the bottom plate.

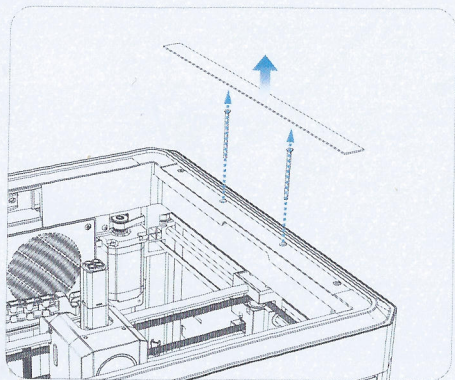

31. Peel off the foam pad on the right side and remove the two middle screws.

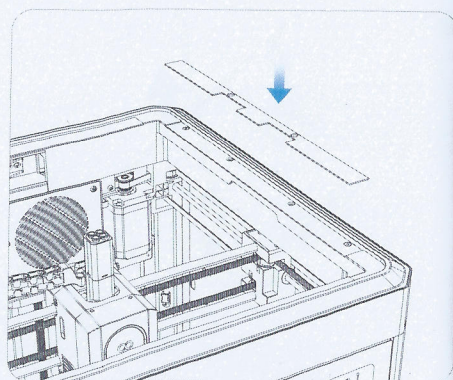

32. Align the holes and attach the new foam pad. (Note: There are two foam pad sizes. Please select the one that matches your machine before applying it)

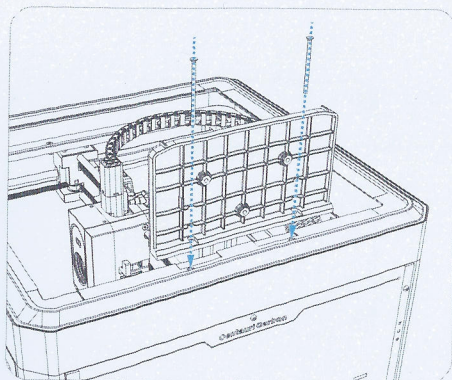

33. Install the CANVAS mounting bracket using two M3x50 screws.

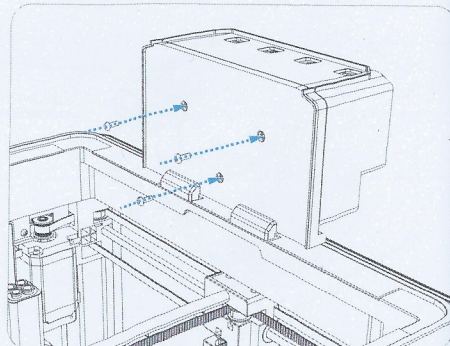

34. Install the CANVAS feeding module using three M3x8 screws.

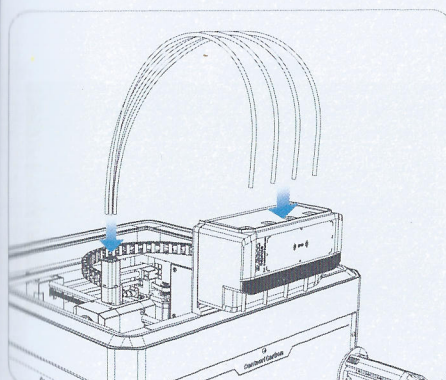

35. Install the PTFE tubes.

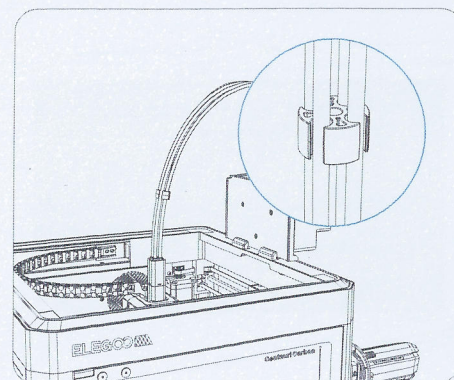

36. Secure the PTFE tubes with the clip.

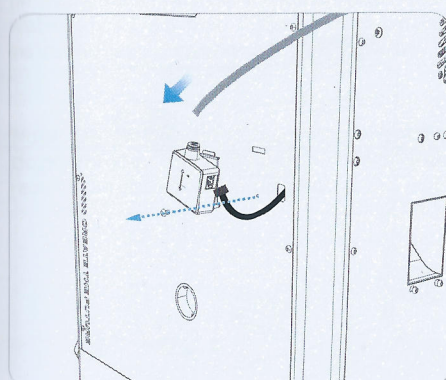

37. Disconnect the filament runout sensor cable, remove the screw, and take off the sensor. (Note: At the same time, remove the existing PTFE tube from the cable chain)

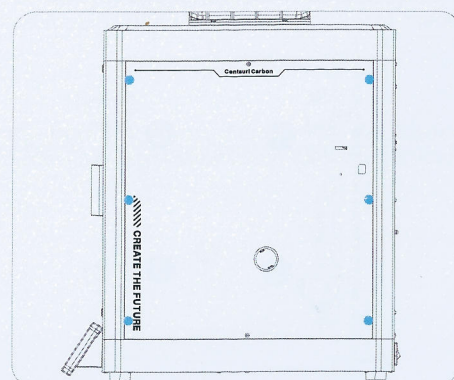

38. Remove the six screws securing the right side panel.

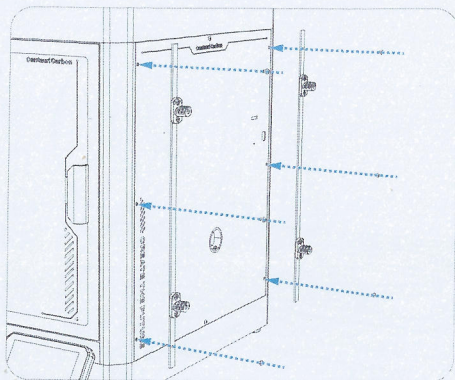

39. Mount the spool holder mounting assembly onto the right side panel using six M3×8 screws. Ensure the toothed side of the spool holder mount faces upward.

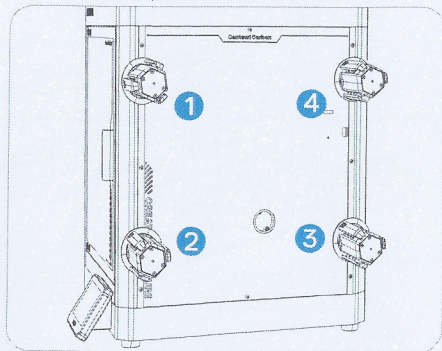

41. Follow the diagram to install each spool holder in its corresponding position.

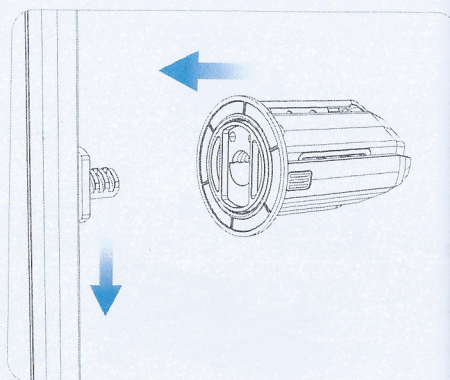

40. Insert the round-hole end of the spool holder into the spool holder mount, and push down firmly to lock it in place.

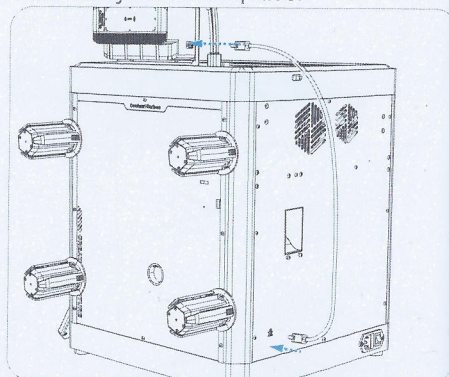

42. Connect the 4-pin cable.

Firmware Upgrade

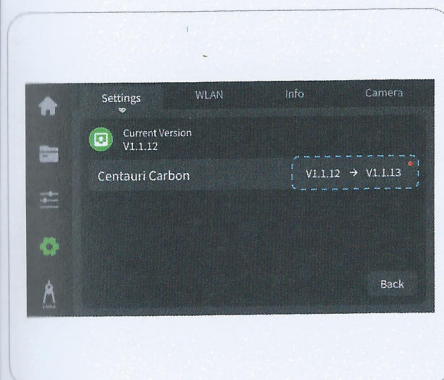

1. Firmware upgrades can be performed via OTA (Over-the-Air) updates or by downloading the firmware package from the official ELEGOO website to a USB drive. Follow the on-screen instructions to proceed with the upgrade.

Note: Do not power off the machine during the firmware upgrade process. If upgrading via USB drive, do not remove the USB drive until the upgrade is complete. Failure to follow these instructions may result in an unsuccessful upgrade.

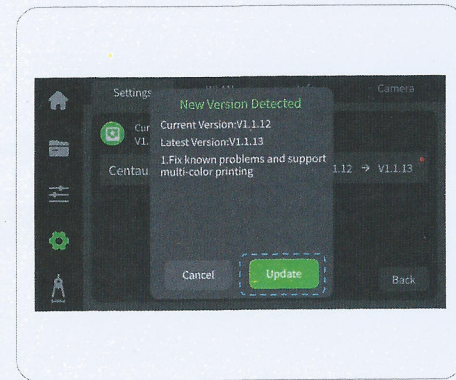

2. Tap the "Update" button to initiate the upgrade process. Wait for the machine to complete the upgrade before enabling multicolor printing.

Load the Filament

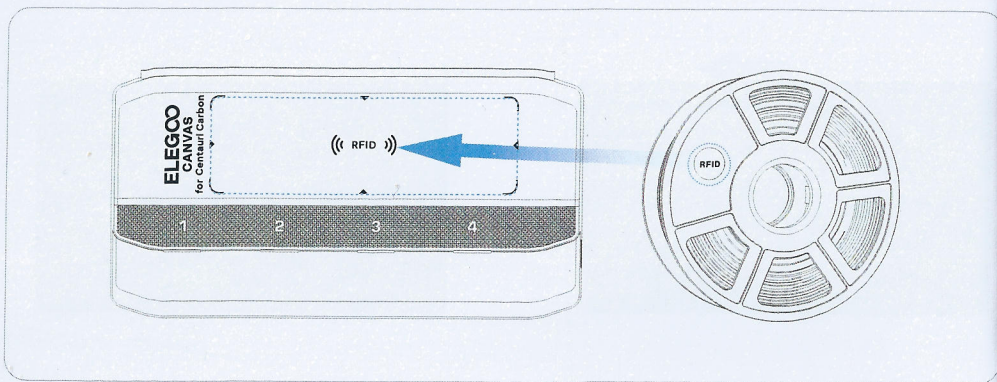

1. If the filament supports RFID tag recognition, align the RFID tag on the filament spool with the RFID detection area on the CANVAS. When you hear a beep, the CANVAS has successfully recognized the filament information;

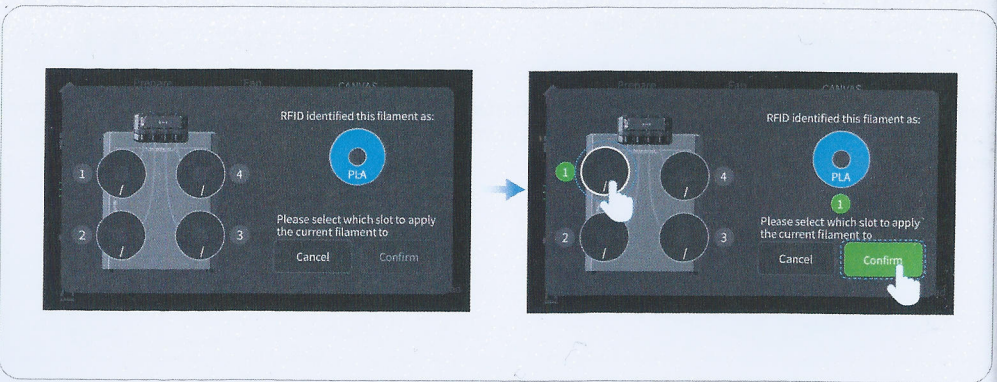

2. On the touchscreen, select the corresponding number for the spool holder where the filament will be installed, then tap "Confirm" to automatically write the filament information;

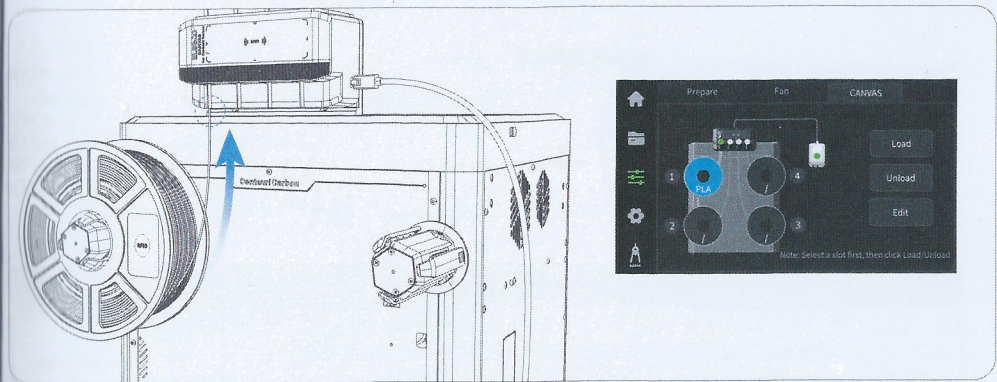

3. Mount the filament spool onto its numbered holder and insert the filament into the matching inlet on the CANVAS. When the filament detection switch senses the filament, the machine will automatically feed it to the ready position;

4. Repeat the above steps for all filaments to be loaded.

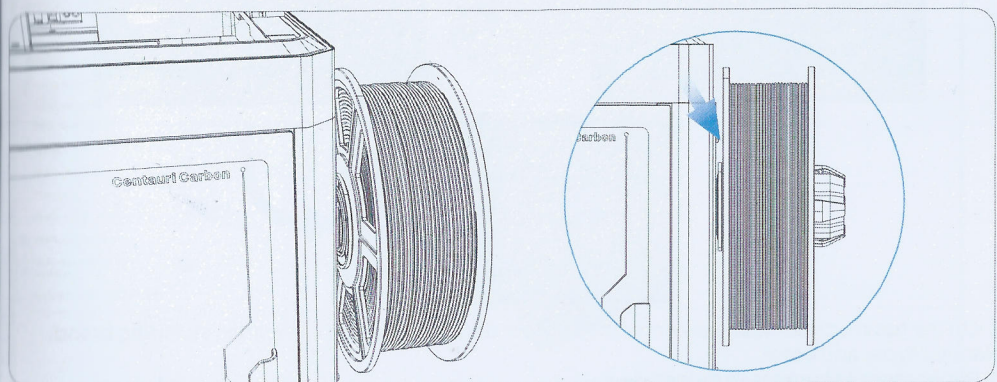

Note: Push the spool fully into place and seat it against the stop on the holder to prevent it from falling off or becoming tangled.

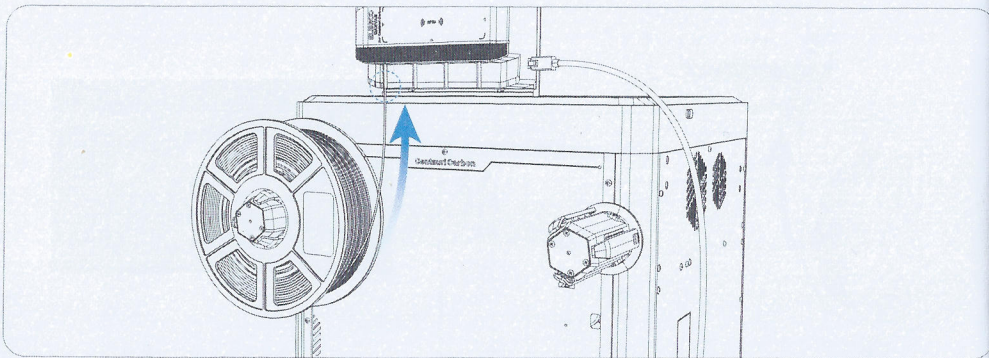

1. If the filament does not support RFID tag recognition, manually enter the filament information.

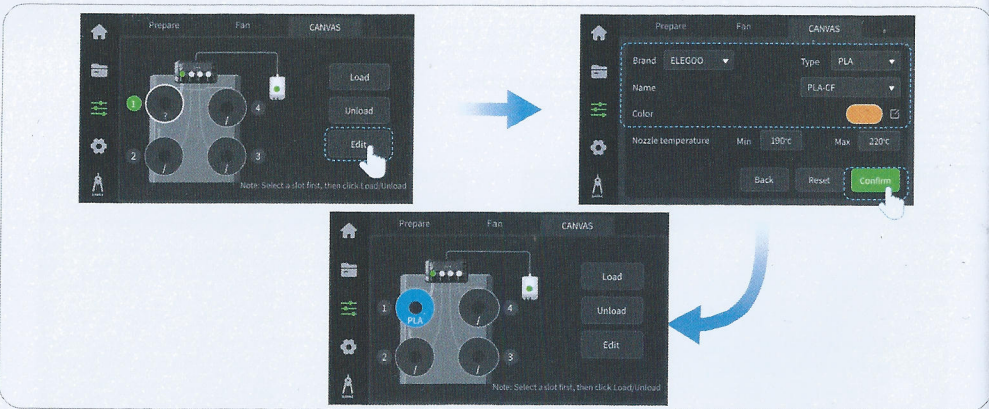

2. On the touchscreen, manually enter the filament details for each spool holder, including brand, filament type, and color.

3. Repeat for all filaments to be installed.

Note: Filament with RFID tags can also be entered manually if desired.

ElegooSlicer

1. To slice a multicolor model:

- 1 Drag and drop a model file into the slicer, or click "File" in the upper-left corner to import a model. Try one of the included sample files for your first test.
- 2 Click "+" on the left toolbar to add filament.
- 3 Set the filament type and color for each spool.
- 4 Select the model, then click "Color painting" in the upper right (or press N) to enter paint mode.
- 5 Click "Slice plate" and wait for the process to complete.

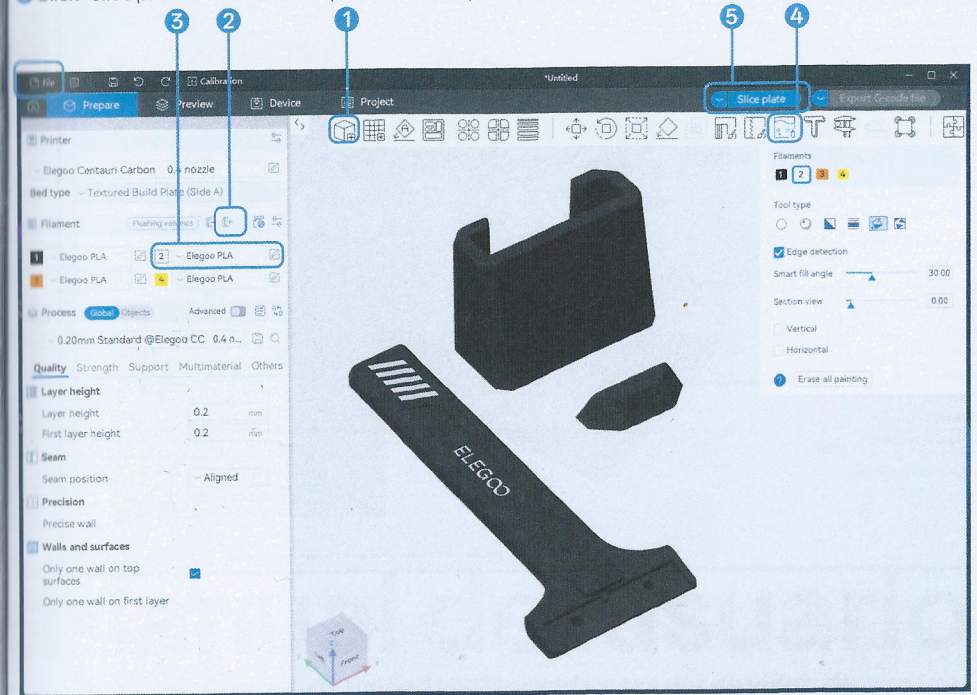

2. After slicing is complete, click "Print" in the upper-right corner to send the task directly to the printer, or select "Export G-code file" to save the file to a USB drive for offline printing.

