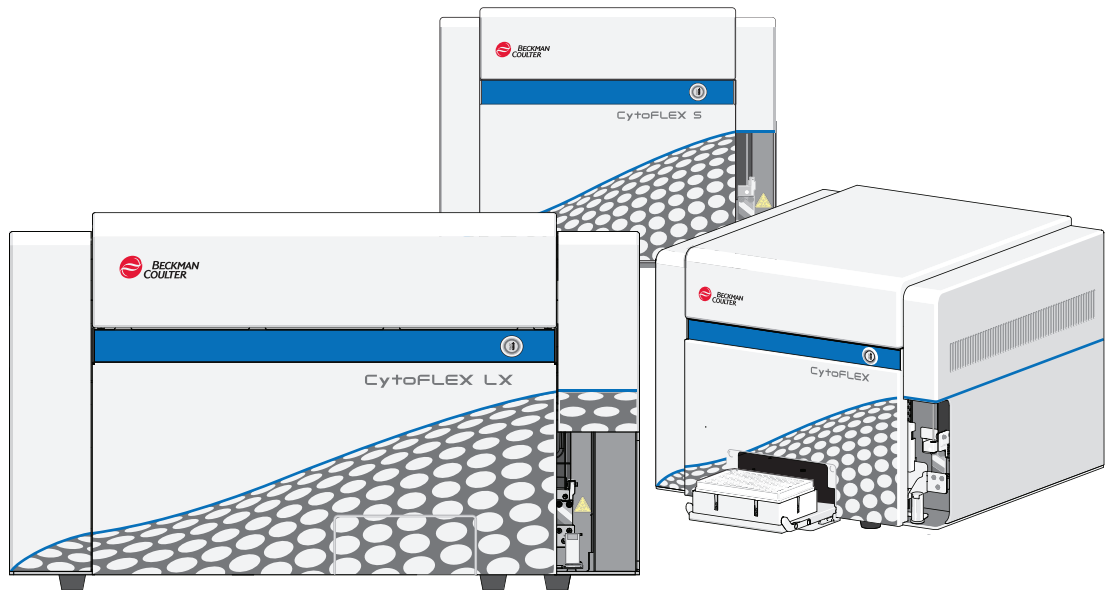


# Instructions for Use

## CytoFLEX Platform

CytoFLEX, CytoFLEX S, and CytoFLEX LX Flow Cytometers

For Research Use Only. Not for use in diagnostic procedures.



B49006AT  
November 2023



Beckman Coulter, Inc.  
250 S. Kraemer Blvd.  
Brea, CA 92821 U.S.A.



## **CytoFLEX Platform Flow Cytometer**

PN B49006AT (November 2023)

© 2023 Beckman Coulter, Inc.

All rights reserved.

Beckman Coulter, the stylized logo, and the Beckman Coulter product and service marks mentioned herein are trademarks or registered trademarks of Beckman Coulter, Inc. in the United States and other countries.

Windows 7, Windows 8, and Windows 10 are registered trademarks or trademarks of Microsoft Corporation in the United States and/or other countries.

*All other trademarks are the property of their respective owners.*

### **Contact Us**

If you have any questions, contact our Customer Support Center.

- Worldwide, find us via our website at [www.beckman.com/support/technical](http://www.beckman.com/support/technical)
- In the USA and Canada, call us at 1-800-369-0333.
- In Austria, call us at 0810 300484.
- In Germany, call us at 02151 333999.
- In Sweden, call us at +46(0)8 564 859 14.
- In the Netherlands, call us at +31 348 799 815.
- In France, call us at 0825838306 6.
- In the UK, call us at +44 845 600 1345.
- In Ireland, call us at +353 (01) 4073082.
- In Italy, call us at +39 0295392 456.
- In other locales, contact your local Beckman Coulter Representative.

 Beckman Coulter (UK) Ltd.  
Oakley Court  
Kingsmead Business Park, London Road  
High Wycombe  
United Kingdom HP11 1JU  
01494 441181

Glossary of Symbols is available at [beckman.com/techdocs](http://beckman.com/techdocs) (PN C24689).

*May be covered by one or more pat. - see  
[www.beckman.com/patents](http://www.beckman.com/patents)*

Original Instructions

# Revision History

## **Initial Issue AA, 09/2014**

Software Version 1.0

## **Issue AB, 12/2014**

Software Version 1.0

Updates were made to the following sections: Symbol Explanations, Figure 1.10, Figure 1.11, Figure 9.3, Figure 9.5, Figure 9.6, Figure 9.7, Disposal Of Electrical Instrumentation, Lifting and Carrying Instructions, Replacing the Sheath Fluid Harness and/or Waste Harness, and Installing the Instrument and Connecting the Equipment.

## **Issue AC, 02/2015**

Software Version 1.1

Updates were made to the following sections:

Safety Notices

- Symbol Explanations

CHAPTER 1, System Overview

- Optical Fiber

- Fluidics Module

- Plate Loader Components

- System Configuration

- Instrument Specifications

- Performance Characteristics

CHAPTER 2, Using the CytExpert Software

- Start Page

- Acquisition Screen

- Test Tubes

- Plot area

- Status Bar

- Analysis Screen

- Compensation Experiment Screen

- QC Experiment Screen

- Software Menu

- Graphic and Gating Styles

- Software Settings

CHAPTER 3, Daily Startup

- Opening the Software

- Selecting the Plate Loader Sample Injection Mode [With Plate Loader]

- Running the System Startup Program

- Running the System Startup Program [With Plate Loader]

*This document applies to the latest software listed and higher versions. When a subsequent software version affects the information in this document, a new issue will be released to the Beckman Coulter Web site. For labeling updates, go to [www.beckman.com](http://www.beckman.com) and download the latest version of the manual or system help for your instrument.*

CHAPTER 4, Instrument Quality Control

- Preparing the QC Sample [With Plate Loader]
- Collecting QC Data
- Confirming Results
- Collecting QC Data [With Plate Loader]
- Creating Levey-Jennings Charts
- QC Result Manager

CHAPTER 5, Data Acquisition and Sample Analysis

- Creating an Experiment
- Creating an Experiment [With Plate Loader]
- Sampling and Collecting Data
- Setting the Channel and Label
- Adjusting the Threshold
- Creating Plots and Gates
- Setting Customized Parameters
- Setting Custom Statistics
- Analyzing and Exporting Data
- Exporting FCS Files
- Exporting Plots or the Statistics Table of Multiple Tubes as Picture Files
- Printing Graphics

CHAPTER 6, Compensation

- Creating a Compensation Experiment
- Creating a Compensation Experiment [With Plate Loader]
- Manually Adjusting Compensation
- Managing the Compensation Library

CHAPTER 7, Data Review

- Calculating Sample Injection Volume and Concentration
- Importing Previously Acquired Data

CHAPTER 9, Troubleshooting

- Plate Loader Hazard Labels and Location
- Table 9.2, Troubleshooting [With Plate Loader]

CHAPTER 10, Cleaning Procedures

- Daily Clean [With Plate Loader]
- Preparing the Instrument for Transport or Storage

*This document applies to the latest software listed and higher versions. When a subsequent software version affects the information in this document, a new issue will be released to the Beckman Coulter Web site. For labeling updates, go to [www.beckman.com](http://www.beckman.com) and download the latest version of the manual or system help for your instrument.*

## CHAPTER 11, Replacement/Adjustment Procedures

- Adding the Deep Clean Solution
- Replacing the Sample Probe Assembly [With Plate Loader]
- Changing the Sample Probe from the Single Tube Sample Station to the Plate Loader [With Plate Loader]
- Changing the Sample Probe from the Plate Loader to the Single Tube Sample Station [With Plate Loader]
- Replacing the Plate Holder [With Plate Loader]
- Plate Loader Module Removal and Reinstallation [With Plate Loader]
- Calibrating the Sample Flow Rate
- Calibrating the Sample Flow Rate [With Plate Loader]
- Changing Sample Mixing and Backflush Settings
- Calibrating the Plate Position [With Plate Loader]

## APPENDIX A, Instrument Installation

- Power Source
- Unpacking the Instrument and Inspecting the Materials for Defects or Omissions
- Installing the CytExpert Software

**Issue AD, 04/2015**

Software Version 1.1

Updates were made to the following sections:

## CHAPTER 1, System Overview

- Cytometer

## CHAPTER 2, Using the CytExpert Software

- Analysis Screen

## CHAPTER 8, Daily Shutdown

- Shutting Down the Instrument

## CHAPTER 11, Replacement/Adjustment Procedures

- Changing the Event Rate Setting
- Calibrating the Plate Position [With Plate Loader]

**Issue AE, 11/2015**

Software Version 1.1

Updates were made to the following sections:

## CHAPTER 1, System Overview

- Plate Loader Components
- Plate Holder Components
- Dimensions [CytoFLEX]
- Acoustic Noise Level
- Performance Characteristics

## CHAPTER 4, Instrument Quality Control

- Confirming Results

*This document applies to the latest software listed and higher versions. When a subsequent software version affects the information in this document, a new issue will be released to the Beckman Coulter Web site. For labeling updates, go to [www.beckman.com](http://www.beckman.com) and download the latest version of the manual or system help for your instrument.*

CHAPTER 9, Troubleshooting

Plate Loader Hazard Labels and Location

CHAPTER 10, Cleaning Procedures

Daily Clean

Daily Clean [With Plate Loader]

Preparing the Instrument for Transport or Storage

CHAPTER 11, Replacement/Adjustment Procedures

Replacing the Sample Probe Assembly [With Plate Loader]

Replacing the Plate Holder [With Plate Loader]

Plate Loader Module Removal and Reinstallation [With Plate Loader]

APPENDIX A, Instrument Installation

Installing the Instrument and Connecting the Equipment

**Issue AF, 10/2016**

Software Version 1.1

Updates were made to the following sections:

Safety Notices

Safety Precautions

Introduction

About this Manual

CHAPTER 11, Replacement/Adjustment Procedures

Changing the Sample Probe from the Single Tube Sample Station to the Plate Loader [With Plate Loader]

Changing the Sample Probe from the Plate Loader to the Single Tube Sample Station [With Plate Loader]

CytoFLEX Plate Loader Upgrade Kit

CytoFLEX Plate Loader Upgrade Kit Components

Changing the Sample Probe from the Single Tube Sample Station to the Plate Loader [With CytoFLEX Plate Loader Upgrade Kit]

Changing the Sample Probe from the Plate Loader to the Single Tube Sample Station [With CytoFLEX Plate Loader Upgrade Kit]

**Issue AG, 01/2017**

Software Version 2.0

Complete Revision

**Issue AH, 03/2017**

Software Version 2.0

Updates were made to the following sections:

Introduction

About this Manual

*This document applies to the latest software listed and higher versions. When a subsequent software version affects the information in this document, a new issue will be released to the Beckman Coulter Web site. For labeling updates, go to [www.beckman.com](http://www.beckman.com) and download the latest version of the manual or system help for your instrument.*

## CHAPTER 1, System Overview

- Performance Characteristics [CytoFLEX]
- Performance Characteristics [CytoFLEX LX]

## CHAPTER 3, Daily Startup

- Selecting the Plate Loader Sample Injection Mode [With Plate Loader]

## CHAPTER 11, Replacement/Adjustment Procedures

- Managing the Maintenance Reminder
- Replacing the Sample Probe and/or the Sample Peristaltic Pump Tubing
- Replacing the Sample Probe Assembly [With Plate Loader]
- Changing the Sample Probe from the Single Tube Sample Station to the Plate Loader [CytoFLEX With Plate Loader]
- Changing the Sample Probe from the Plate Loader to the Single Tube Sample Station [CytoFLEX With Plate Loader]
- Changing Sample Mixing and Backflush Settings

## APPENDIX A, Instrument Installation

- Installing the Software [CytoFLEX]
- Upgrading the CytExpert Software
- Reinstalling the CytExpert Software

Added the following Chapter:

## APPENDIX C, Sample Injection Mode Control Kit

**Issue AJ**, 05/2017

Software Version 2.0

Updates were made to the following sections:

## CHAPTER 1, System Overview

- Consumables and Supplies

## CHAPTER 4, Instrument Quality Control and Standardization

- Preparing the QC Sample
- Preparing the QC Sample [With Plate Loader]
- Importing Lot-Specific Target Values

## CHAPTER 5, Data Acquisition and Sample Analysis

- Setting Sample Wells

## CHAPTER 9, Troubleshooting

- Table 9.1

*This document applies to the latest software listed and higher versions. When a subsequent software version affects the information in this document, a new issue will be released to the Beckman Coulter Web site. For labeling updates, go to [www.beckman.com](http://www.beckman.com) and download the latest version of the manual or system help for your instrument.*

Issue AK, 08/2017

Software Version 2.1

Updates were made to the following sections:

CHAPTER 1, System Overview

- Product Description
- Wavelength Division Multiplexer (WDM)
- WDM Optical Filter Mount Color Codes [CytoFLEX LX]
- Optical Fiber
- System Configuration
- Performance Characteristics

CHAPTER 2, Using the CytExpert Software

- Start Page
- Acquisition Screen
- Software Menu
- Acquisition and Analysis Screen Menu
- Advanced Menu
- Account Menu
- Log Menu
- Signature Menu
- Backup/Restore Menu
- Viewing and Exporting User Logs

CHAPTER 3, Daily Startup

- Logging into the Software
- Selecting the Proper Sample Injection Mode

CHAPTER 4, Instrument Quality Control and Standardization

- Overview
- Importing Lot-Specific Target Values
- Confirming Results

CHAPTER 5, Data Acquisition and Sample Analysis

- Creating an Experiment [With Plate Loader]
- Add Plate from Layout
- Setting Sample Wells
- Creating a Heat Map
- Modifying Existing Heat Map Settings

*This document applies to the latest software listed and higher versions. When a subsequent software version affects the information in this document, a new issue will be released to the Beckman Coulter Web site. For labeling updates, go to [www.beckman.com](http://www.beckman.com) and download the latest version of the manual or system help for your instrument.*

- Creating Plots and Gates
- Sampling and Collecting Data
- Setting the Channel and Label
- Setting Collection Conditions
- Laser Settings
- Analyzing and Exporting Data
- Printing Graphics
- CHAPTER 6, Compensation
  - Creating a Compensation Experiment
  - Manually Adjusting Compensation
- CHAPTER 8, Daily Shutdown
  - Shutting Down the Instrument
- CHAPTER 9, Troubleshooting
  - Laser Beam Hazards
  - Laser Warning Labels
  - Backup and Restore
- CHAPTER 11, Replacement/Adjustment Procedures
  - Calibrating the Sample Flow Rate
- APPENDIX A, Instrument Installation
  - Unpacking the Instrument and Inspecting the Materials for Defects or Omissions [CytoFLEX]
- APPENDIX B, CytExpert Electronic Record Management
  - Figure B.3
  - Printing an Experiment Signature
- APPENDIX D, Table of Hazardous Substances
  - APPENDIX D, Table of Hazardous Substances Name and Concentration [CytoFLEX 355]
- Issue AL, 11/2017**
- Software Version 2.2
- Updates were made to the following sections:
  - Safety Notices
    - Symbol Explanations
  - Introduction
    - Conventions Used

*This document applies to the latest software listed and higher versions. When a subsequent software version affects the information in this document, a new issue will be released to the Beckman Coulter Web site. For labeling updates, go to [www.beckman.com](http://www.beckman.com) and download the latest version of the manual or system help for your instrument.*

CHAPTER 1, System Overview

- Product Description
- Sample Station
- Plate Loader Components
- Instrument Specifications
- Performance Characteristics

CHAPTER 2, Using the CytExpert Software

- Start Page
- Software Menu
- Advanced Menu
- Plate Type Library

CHAPTER 3, Daily Startup

- Selecting the Plate Loader Sample Injection Mode [With Plate Loader]
- Running the System Startup Program [with the Single Tube Loader]
- Running the System Startup Program [With Plate Loader]

CHAPTER 4, Instrument Quality Control and Standardization

- Preparing the QC Sample [With Plate Loader]
- Collecting QC Data [With Plate Loader]
- Confirming Results

CHAPTER 9, Troubleshooting

- Plate Loader Hazard Labels and Location
- Troubleshooting Table

CHAPTER 10, Cleaning Procedures

- Surface Cleaning and Disinfection

CHAPTER 11, Replacement/Adjustment Procedures

- Managing the Maintenance Reminder
- Replacing the Sheath Fluid Filter
- Replacing the Plate Holder [With Plate Loader]
- Calibrating the Plate Position [With Plate Loader]

APPENDIX A, Instrument Installation

- Power Source

APPENDIX C, Sample Injection Mode Control Kit

- Performance Characteristics [With the Sample Injection Mode Control Knob]

APPENDIX D, Deep Well Plate

- Specimen Collection Plate Specifications

*This document applies to the latest software listed and higher versions. When a subsequent software version affects the information in this document, a new issue will be released to the Beckman Coulter Web site. For labeling updates, go to [www.beckman.com](http://www.beckman.com) and download the latest version of the manual or system help for your instrument.*

**Issue AM, 07/2018**

Software Version 2.3

Updates were made to the following sections:

## Safety Notices

Safety Precautions

Symbol Explanations

## CHAPTER 1, System Overview

Wavelength Division Multiplexer (WDM)

Fluidics Module

Consumables and Supplies

Instrument Specifications

Performance Characteristics

## CHAPTER 2, Using the CytExpert Software

Start Page

Software Menu

Settings Menu

Signature Menu

Role Management

Account Policies

User Management Operation Log

Plate Type Library

## CHAPTER 3, Daily Startup

Logging into the Software

Logging Out of the Software

Locking the Account

Running the System Startup Program [with the Single Tube Loader]

Running the System Startup Program [With Plate Loader]

## CHAPTER 4, Instrument Quality Control and Standardization

Overview

Importing Lot-Specific Target Values

Confirming Results

## CHAPTER 5, Data Acquisition and Sample Analysis

Verifying, Selecting, Editing, and Creating Detector Configuration

Creating Plots and Gates

Printing Graphics

## CHAPTER 10, Cleaning Procedures

Preparing the Instrument for Transport or Storage

*This document applies to the latest software listed and higher versions. When a subsequent software version affects the information in this document, a new issue will be released to the Beckman Coulter Web site. For labeling updates, go to [www.beckman.com](http://www.beckman.com) and download the latest version of the manual or system help for your instrument.*

CHAPTER 11, Replacement/Adjustment Procedures

Replacing the Sample Probe and/or the Sample Peristaltic Pump Tubing  
Calibrating the Plate Position [With Plate Loader]

CHAPTER A, Instrument Installation

Installing the Instrument and Connecting the Equipment [CytoFLEX]  
Installing the CytExpert Software

APPENDIX B, CytExpert Electronic Record Management

Experiment Management  
Electronic Signature  
User Management

APPENDIX E, Custom Optical Filters

Overview  
Installing a Custom Optical Filter

**Issue AN, 07/2019**

Software Version 2.3

Updates were made to the following sections:

CHAPTER 1, System Overview

Main Components  
Plate Holder Components  
Sample Station  
System Configuration  
Instrument Specifications

CHAPTER 5, Data Acquisition and Sample Analysis

Creating Plots and Gates  
Creating and Adjusting Auto Gates  
Analyzing and Exporting Data

CHAPTER 6, Compensation

Creating a Compensation Experiment  
Creating a Compensation Experiment [With Plate Loader]

CHAPTER 9, Troubleshooting

Biohazard Label and Location

CHAPTER 10, Cleaning Procedures

Daily Clean  
Daily Clean [With Plate Loader]  
Cleaning the Sample Station

CHAPTER 11, Replacement/Adjustment Procedures

Replacing the Sample Probe and/or the Sample Peristaltic Pump Tubing

*This document applies to the latest software listed and higher versions. When a subsequent software version affects the information in this document, a new issue will be released to the Beckman Coulter Web site. For labeling updates, go to [www.beckman.com](http://www.beckman.com) and download the latest version of the manual or system help for your instrument.*

## CHAPTER A, Instrument Installation

- Instrument Transportation and Storage
- Installing the Software [CytoFLEX Platform]

## APPENDIX E, Custom Optical Filters

- Installing a Custom Optical Filter

**Issue AP**, 11/2019

Software Version 2.4

Updates were made to the following sections:

## CHAPTER 1, System Overview

- Wavelength Division Multiplexer (WDM)
- Plate Holder Components
- Cytometer
- Reagent Limitations

## CHAPTER 2, Using the CytExpert Software

- Start Page
- Software Menu

## CHAPTER 3, Operation Principles

- Overview
- Sample Flow
- Laser Beam Shaping
- Cell Illumination
- Light Collection, Separation and Measurement
- Signal Processing
- Data Storage
- Automated Software Features
- Parameters
- Plot Display
- Statistics

## CHAPTER 4, Daily Startup

- Logging into the Software

## CHAPTER 5, Instrument Quality Control and Standardization

- Overview
- Preparing the QC Sample
- Preparing the QC Sample [With Plate Loader]
- Importing Lot-Specific Target Values
- Collecting QC Data
- Collecting QC Data [With Plate Loader]
- Confirming Results

*This document applies to the latest software listed and higher versions. When a subsequent software version affects the information in this document, a new issue will be released to the Beckman Coulter Web site. For labeling updates, go to [www.beckman.com](http://www.beckman.com) and download the latest version of the manual or system help for your instrument.*

- Preparing the Standardization Sample
- Generating Target Median Values
- Adding a New Standardization Item
- Performing the Standardization
- Applying the Standardized Acquisition Settings
- Standardization Target Library

CHAPTER 6, Data Acquisition and Sample Analysis

- Creating an Experiment
- Adjusting the Threshold
- Verifying, Selecting, Editing, and Creating Detector Configuration
- Sampling and Collecting Data [Without Plate Loader]
- Sampling and Collecting Data [With Plate Loader]
- Exporting Plots or the Statistics Table of Multiple Tubes as Picture Files

CHAPTER 7, Compensation

- Creating a Compensation Experiment

CHAPTER 12, Replacement/Adjustment Procedures

- Replacing the Plate Holder [With Plate Loader]

CHAPTER A, Instrument Installation

- Installing the Instrument and Connecting the Equipment [CytoFLEX]

APPENDIX F, WDM Beam Splitter

- Overview
- Modifying Detector Configuration [With WDM Beam Splitter]

APPENDIX G, Cyber Security

- Good Practices for Cyber Security

**Issue AR, 08/2021**

Software Version 2.4

Updates were made to the following sections:

CHAPTER 1, System Overview

- Consumables and Supplies
- Performance Characteristics

CHAPTER 5, Instrument Quality Control and Standardization

- Overview
- Preparing the QC Sample
- Preparing the QC Sample [With Plate Loader]
- Importing Lot-Specific Target Values
- Collecting QC Data
- Collecting QC Data [With Plate Loader]

*This document applies to the latest software listed and higher versions. When a subsequent software version affects the information in this document, a new issue will be released to the Beckman Coulter Web site. For labeling updates, go to [www.beckman.com](http://www.beckman.com) and download the latest version of the manual or system help for your instrument.*

## CHAPTER 10, Troubleshooting

Hazard Labels and Locations

Troubleshooting Table

## CHAPTER 12, Replacement/Adjustment Procedures

Changing Sample Mixing and Backflush Settings

## APPENDIX C, Sample Injection Mode Control Kit

Performance Characteristics [With the Sample Injection Mode Control Knob]

**Issue AS, 12/2021**

Software Version 2.5

Updates were made to the following sections:

## CHAPTER 1, System Overview

Cytometer

## CHAPTER 2, Using the CytExpert Software

Start Page

Software Menu

## CHAPTER 4, Daily Startup

Logging into the Software

## CHAPTER 5, Instrument Quality Control and Standardization

Collecting QC Data

Confirming Results

Applying the Standardized Acquisition Settings

## CHAPTER 6, Data Acquisition and Sample Analysis

Creating Plots and Gates

Verifying, Selecting, Editing, and Creating Detector Configuration

Importing and Exporting Instrument Settings

## APPENDIX A, Instrument Installation

Installing the CytExpert Software

## APPENDIX G, Good Practices for Cyber Security

Drive Encryption

Protection from Malware Software

Operating System Updates

System Hardening

*This document applies to the latest software listed and higher versions. When a subsequent software version affects the information in this document, a new issue will be released to the Beckman Coulter Web site. For labeling updates, go to [www.beckman.com](http://www.beckman.com) and download the latest version of the manual or system help for your instrument.*

Issue AT, 11/2023

Software Version 2.6

Updates were made to the following sections:

Safety Notices

Symbol Explanations

Electromagnetic Compatibility (EMC)

CHAPTER 1, System Overview

Maximum Altitude

Cytometer

CHAPTER 6, Data Acquisition and Sample Analysis

Verifying, Selecting, Editing, and Creating Detector Configuration

CHAPTER 9, Daily Shutdown

Running Daily Clean

Shutting Down the Instrument

CHAPTER 10, Troubleshooting

Restore

Log Cleanup

CHAPTER 11, Cleaning Procedures

Daily Clean

Daily Clean [With Plate Loader]

CHAPTER 12, Replacement/Adjustment Procedures

Unclogging the Sample Probe [With Sample Injection Mode Control Kit]

Unclogging the Sample Probe [Without Sample Injection Mode Control Kit]

Replacing the Sample Probe and/or the Sample Peristaltic Pump Tubing

Replacing the Optical Filter

APPENDIX A, Instrument Installation

CytExpert Software Installation Options

Installing the CytExpert Software

Upgrading the CytExpert Software

APPENDIX F, WDM Beam Splitter

Modifying Detector Configuration [With WDM Beam Splitter]

APPENDIX G, Good Practices for Cyber Security

Installing McAfee Application Control

Operating System Updates

Notification Options

Recovering from Failed Operating System Updates

Note: Changes that are part of the most recent revisions are indicated in text by a bar in the margin of the amended page.

*This document applies to the latest software listed and higher versions. When a subsequent software version affects the information in this document, a new issue will be released to the Beckman Coulter Web site. For labeling updates, go to [www.beckman.com](http://www.beckman.com) and download the latest version of the manual or system help for your instrument.*

# Safety Notices

Read all product manuals and consult with Beckman Coulter-trained personnel before attempting to operate the instrument. Do not attempt to perform any procedure before carefully reading all instructions. Always follow product labeling and manufacturer's recommendations. If in doubt as to how to proceed in any situation, [contact us](#).

Beckman Coulter, Inc. urges its customers to comply with all national health and safety standards such as the use of barrier protection. This may include, but it is not limited to, protective eyewear, gloves, and suitable laboratory attire when operating or maintaining this or any other automated laboratory analyzer.

This manual assumes that users have basic knowledge of the Windows operating system, as well as experience working with laboratory testing technology. Users are invited to consult the appropriate documentation for such information.

## Alerts for Danger, Warning, and Caution

---



**DANGER** indicates an imminently hazardous situation which, if not avoided, will result in death or serious injury.



**WARNING** indicates a potentially hazardous situation which, if not avoided, could result in death or serious injury.



**CAUTION** indicates a potentially hazardous situation, which, if not avoided, may result in minor or moderate injury. It may also be used to alert against unsafe practices.

## Safety Precautions

---

### **WARNING**

Risk of operator injury if:

- All doors, covers and panels are not closed and secured in place prior to and during instrument operation.
- The integrity of safety interlocks and sensors is compromised.
- Instrument alarms and error messages are not acknowledged and acted upon.
- You contact moving parts.
- You mishandle broken parts.
- Doors, covers and panels are not opened, closed, removed and/or replaced with care.
- Improper tools are used for troubleshooting.

To avoid injury:

- Keep doors, covers and panels closed and secured in place while the instrument is in use.
- Take full advantage of the safety features of the instrument.
- Acknowledge and act upon instrument alarms and error messages.
- Keep away from moving parts.
- Report any broken parts to your Beckman Coulter Representative.
- Open/remove and close/replace doors, covers and panels with care.
- Use the proper tools when troubleshooting.

### **CAUTION**

System integrity could be compromised and operational failures could occur if:

- This equipment is used in a manner other than specified. Operate the instrument as instructed in the Product Manuals.
- You introduce software that is not authorized by Beckman Coulter into your computer. Only operate your system's computer with software authorized by Beckman Coulter.
- You install software that is not an original copyrighted version. Only use software that is an original copyrighted version to prevent virus contamination.

### **CAUTION**

If you purchased this product from anyone other than Beckman Coulter or an authorized Beckman Coulter distributor, and, it is not presently under a Beckman Coulter service maintenance agreement, Beckman Coulter cannot guarantee that the product is fitted with the most current mandatory engineering revisions or that you will receive the most current information bulletins concerning the product. If you purchased this product from a third party and would like further information concerning this topic, [contact us](#).






 **CAUTION**





Risk of instrument damage. This device is intended for indoor use only. To avoid device damage, do not install the instrument outdoors.



 **WARNING**

Risk of personal injury. Safety protection can be impaired if used in a manner not specified by the manufacturer. To avoid personal injury, use the instrument according to the manufacturer's instructions only.

## Symbol Explanations

Symbol	Warning Condition	Action
	Biohazard Symbol	Consider all materials (specimens, reagents, controls, and monoclonal antibodies) and areas these materials come into contact with as being potentially infectious.  Wear appropriate barrier protection and follow safe laboratory procedures when handling any material in the laboratory.
	Caution	To indicate that caution is necessary when operating the device or control close to where the symbol is placed, or to indicate that the current situation needs operator awareness or operator action in order to avoid undesirable consequences.
	Caution, Risk of Electric Shock	To indicate hazards arising from dangerous voltages.
	Warning, Sharp elements	To warn of sharp element.
	Warning, Crushing of hands	To warn of a closing motion of mechanical parts of equipment.

Symbol	Warning Condition	Action
	Recycling Symbol WEEE Wheeled Bin Symbol	<p>The symbol of a crossed-out wheeled bin on the product is required in accordance with the Waste Electrical and Electronic Equipment (WEEE) Directive of the European Union. The presence of this marking on the product indicates:</p> <ol style="list-style-type: none"> <li>1. that the device was put on the European Market after August 13, 2005 and</li> <li>2. that the device is not to be disposed via the municipal waste collection system of any member state of the European Union.</li> </ol> <p>For products under the requirement of WEEE directive, please contact your dealer or local Beckman Coulter office for the proper decontamination information and take-back program which will facilitate the proper collection, treatment, recovery, recycling, and safe disposal of device.</p> <p>For the Japan market:</p> <p>This system is considered an industrial waste, subject to special controls for infectious waste. Before disposal of the system, refer to the Waste Disposal and Public Cleaning Law for compliance procedures.</p>
	Laser Radiation	The laser radiation symbol indicates that there can be laser light radiation in the area. Take precautions to prevent exposure.
	RoHS Caution Symbol	This label indicates that the electronic information product contains certain toxic or hazardous substances. The center number is the Environmentally Friendly Use Period (EFUP) date, and indicates the number of calendar years the product can be in operation. Upon the expiration of the EFUP, the product must be immediately recycled. The circling arrows indicate the product is recyclable. The date code on the label or product indicates the date of manufacture.
	Laser Class I	This label indicates that this product is a Class I Laser product. Take precautions to prevent exposure.

Symbol	Warning Condition	Action
	Consider all materials (specimens, controls, monoclonal antibodies, and so forth) as being potentially infectious.	Wear standard laboratory attire and follow safe laboratory procedures when handling any material in the laboratory.
	UKCA Mark	A “UKCA” mark indicates that a product has been assessed before being placed in the UK market, and has been found to meet UK safety, health, and/or environmental protection requirements.

## Electromagnetic Compatibility (EMC)

This device complies with the emissions and immunity requirements as specified in the EN/IEC 61326 series of Product Family Standards for a “basic electromagnetic environment”. Such equipment is supplied directly at low voltage from public mains network. This equipment is not intended for residential use.

### CAUTION

**This device generates, uses, and can radiate unintentional radio-frequency (RF) energy. If this device is not installed and operated correctly, this RF energy can cause interference with other equipment. It is the responsibility of the end user to be sure that a compatible electromagnetic environment for the device can be maintained so that the device operates as intended.**

**In addition, other equipment can radiate RF energy to which this device is sensitive. If one suspects interference between this device and other equipment, Beckman Coulter recommends the following actions to correct the interference:**

- 1. Evaluate the electromagnetic environment before installation and operation of this device.**
- 2. Do not operate this device close to sources of strong electromagnetic radiation (for example: unshielded intentional RF sources), as these can interfere with proper operation. Examples of unshielded intentional radiators are handheld radio transmitters, cordless phones, and cellular phones.**
- 3. Do not place this device near medical electrical equipment that can be susceptible to malfunctions caused by close-proximity to electromagnetic fields.**
- 4. This device has been designed and tested to CISPR 11, Class A emission limits. In a domestic environment, this device may cause radio interference, in which case, you may need to take measures to mitigate the interference.**



# Contents

Revision History, iii

Safety Notices, xvii

Alerts for Danger, Warning, and Caution, xvii

Safety Precautions, xviii

Symbol Explanations, xix

Electromagnetic Compatibility (EMC) , xxi

Introduction, xli

Overview, xli

How to Use Your Manual, xli

About this Manual, xli

Conventions, xliii

Graphics, xliv

## **CHAPTER 1:** System Overview, 1-1

Overview, 1-1

Product Description, 1-1

Main Components, 1-2

Optical Components, 1-4

Wavelength Division Multiplexer (WDM), 1-5

Optical Fiber, 1-16

Fluidics System, 1-17

Fluid Containers/Cubitainers, 1-18

Fluidics Module, 1-19

Sample Station, 1-21

Sample Tube Holder Positions, 1-22

Plate Loader Components, 1-23

Plate Holder Components, 1-27

System Configuration, 1-31

System Configuration [CytoFLEX and CytoFLEX S], 1-31

System Configuration [CytoFLEX LX], 1-33

Consumables and Supplies, 1-35

Reagents, 1-35

- Ordering Information, 1-35
- Instrument Specifications, 1-36
  - Dimensions [CytoFLEX and CytoFLEX S], 1-36
  - Dimensions [CytoFLEX LX], 1-37
  - Installation Category, 1-37
  - Maximum Altitude , 1-38
  - Pollution Degree, 1-38
  - Acoustic Noise Level, 1-38
  - Electrical Ratings, 1-38
  - Cytometer, 1-38
- Performance Characteristics, 1-41
  - Performance Characteristics [CytoFLEX and CytoFLEX S], 1-41
  - Performance Characteristics [CytoFLEX LX], 1-43
- Reagent Limitations, 1-44
- Material Safety Data Sheets (SDS/MSDS), 1-44

## CHAPTER 2: Using the CytExpert Software, 2-1

- Overview, 2-1
- Launching the Software, 2-1
- Main Software Screen, 2-1
  - Start Page, 2-2
  - Acquisition Screen, 2-3
    - Acquisition Screen Navigation, 2-4
    - Collection, 2-5
    - Collection [With Plate Loader], 2-6
    - Test Tubes, 2-7
    - Plot Area, 2-8
    - Status Bar, 2-9
  - Analysis Screen, 2-9
  - Compensation Experiment Screen, 2-11
    - Compensation Controls, 2-11
  - QC Experiment Screen, 2-12
    - QC Report Screen, 2-12
    - QC Experiment Screen, 2-13
    - QC Screen Navigation, 2-13
  - Software Menu, 2-14
    - Acquisition and Analysis Screen Menu, 2-15
- User Management, 2-23
  - Creating, Deleting, and Modifying Users in User Manager, 2-25
  - Unlocking a User Account, 2-27
  - Resetting a User Passwords, 2-27
  - Changing a User Password, 2-27
- Role Management, 2-27
  - Creating, Deleting, and Modifying User Roles in Role Manager, 2-29
- Account Policies, 2-31

User Management Operation Log, 2-33

Graphic and Gating Styles, 2-34

Plots, 2-34

Gates, 2-35

Plate Type Library, 2-36

Adding a Plate Type, 2-37

Editing a Plate Type, 2-41

Duplicating a Plate Type, 2-42

Deleting a Plate Type, 2-44

Software Settings, 2-45

Language Settings, 2-48

Setting Up CytExpert Application Programming Interface (API)

Test Client, 2-48

## **CHAPTER 3: Operation Principles, 3-1**

Overview, 3-1

Sample Flow, 3-1

Sample Loading, 3-1

Hydrodynamic Focusing, 3-2

Laser Beam Shaping, 3-3

Cell Illumination, 3-4

Forward Scatter, 3-4

Side Scatter and Fluorescent Light, 3-4

Light Collection, Separation and Measurement, 3-4

Forward Scatter Collection, 3-4

Side Scatter and Fluorescent Light Collection, 3-5

Side Scatter, 3-5

Fluorescent Light, 3-5

Signal Processing, 3-6

Data Storage, 3-6

Automated Software Features, 3-6

Parameters, 3-7

TIME Parameter, 3-7

Plot Display, 3-7

Statistics, 3-8

## **CHAPTER 4: Daily Startup, 4-1**

Overview, 4-1

Pre-Startup Inspection, 4-1

Checking Waste and Reagent Levels [4 L Fluid Containers], 4-2

Checking Waste and Reagent Levels [10 L Fluid Cubitainers], 4-4

Power Source Inspection, 4-5

- Workstation Connections Inspection, 4-5
- Turning On the Instrument, 4-6
- Logging into the Software, 4-6
  - Logging Out of the Software, 4-9
  - Locking the Account, 4-9
  - Selecting the Proper Sample Injection Mode, 4-9
  - Selecting the Plate Loader Sample Injection Mode [With Plate Loader], 4-12
  - Running the System Startup Program [with the Single Tube Loader], 4-16
  - Running the System Startup Program [With Plate Loader], 4-19
  - Selecting Experiments from the Start Page, 4-27
- Initializing the Instrument, 4-28

## **CHAPTER 5: Instrument Quality Control and Standardization, 5-1**

- Overview, 5-1
- Quality Control, 5-2
  - Preparing the QC Sample, 5-3
    - Required Materials, 5-3
    - CytoFLEX Daily QC Fluorospheres Preparation Process, 5-3
    - CytoFLEX Ready to Use Daily QC Fluorospheres Preparation Process, 5-4
    - CytoFLEX Daily IR QC Fluorospheres Preparation Process, 5-4
  - Preparing the QC Sample [With Plate Loader], 5-5
    - Required Materials, 5-5
    - CytoFLEX Daily QC Fluorospheres Preparation Process, 5-5
    - CytoFLEX Ready to Use Daily QC Fluorospheres Preparation Process, 5-6
    - CytoFLEX Daily IR QC Fluorospheres Preparation Process, 5-6
  - Importing Lot-Specific Target Values, 5-7
  - Collecting QC Data, 5-12
  - Collecting QC Data [With Plate Loader], 5-15
  - Confirming Results, 5-20
    - QC Result Manager, 5-26
- Standardization, 5-27
  - Preparing the Standardization Sample, 5-27
    - Required Materials, 5-28
    - Preparation Process, 5-28
  - Generating Target Median Values, 5-28
  - Adding a New Standardization Item, 5-34
  - Performing the Standardization, 5-38
  - Applying the Standardized Acquisition Settings, 5-41
  - Standardization Target Library, 5-44

## **CHAPTER 6: Data Acquisition and Sample Analysis, 6-1**

- Overview, 6-1

- Creating an Experiment, 6-1
  - Creating an Experiment [Without Plate Loader], 6-1
  - Creating an Experiment [With Plate Loader], 6-3
    - Setting Sample Wells, 6-9
    - Modifying Well Settings, 6-14
  - Setting the Channel and Label, 6-16
  - Creating Plots and Gates, 6-19
  - Creating and Adjusting Auto Gates, 6-28
    - Turning Auto Recalculate On/Off, 6-30
    - Adjusting Autogate Movement and Extent, 6-31
  - Setting Customized Parameters, 6-33
  - Setting Custom Statistics, 6-35
- Configuring Acquisition Settings, 6-38
  - Changing the Tube Name, 6-38
  - Laser Settings, 6-38
    - Setting Laser Target Power Settings [CytoFLEX LX Only], 6-40
  - Adjusting the Gain, 6-41
  - Adjusting the Threshold, 6-43
  - Setting Collection Conditions, 6-44
  - Setting Plot Display Conditions, 6-46
- Load Sample and Record Data, 6-47
  - Before Running Samples, 6-47
  - Verifying, Selecting, Editing, and Creating Detector Configuration, 6-48
  - Setting Up Violet Side Scatter (VSSC) Channel, 6-55
  - Sampling and Collecting Data [Without Plate Loader], 6-58
  - Sampling and Collecting Data [With Plate Loader], 6-61
    - Creating a Heat Map [with Plate Loader], 6-63
    - Refreshing a Heat Map, 6-70
    - Modifying Existing Heat Map Settings, 6-71
    - Deleting an Existing Heat Map, 6-72
    - Exporting a Heat Map, 6-72
- Analyzing and Exporting Data, 6-73
  - Exporting FCS Files, 6-78
  - Exporting Plots or the Statistics Table of Multiple Tubes as Picture Files, 6-80
  - Importing and Exporting Instrument Settings, 6-81
    - Importing and Exporting Compensation Settings, 6-83
  - Printing Graphics, 6-83
- Saving the Experiment, 6-86
  - Concluding the Experiment, 6-86

## CHAPTER 7: Compensation, 7-1

- Overview, 7-1
- Creating a Compensation Experiment, 7-2
  - Preparing the Compensation Sample, 7-4
  - Using Control Samples to Generate the Compensation Matrix, 7-4

- Calculating Compensation Values, 7-8
  - Creating a Compensation Experiment [With Plate Loader], 7-10
    - Preparing the Compensation Sample, 7-13
    - Using Control Samples to Generate the Compensation Matrix, 7-13
    - Calculating Compensation Values, 7-13
  - Creating the Compensation Matrix from Previously Acquired Data, 7-14
  - Adjusting Compensation, 7-16
    - Manually Adjusting Compensation, 7-16
    - Importing and Exporting Compensation, 7-16
      - Importing Compensation Settings from Compensation Matrix Files, 7-16
      - Importing Compensation Settings from the Compensation Library, 7-18
      - Exporting Compensation Settings, 7-19
    - Managing the Compensation Library, 7-21
    - Adding Channels for Compensation, 7-22
- CHAPTER 8: Data Review, 8-1**
  - Overview, 8-1
  - Copying Experiments and Importing Data, 8-1
    - Copying a Previously Acquired Experiment, 8-1
    - Importing Previously Acquired Data, 8-1
  - Setting the Plots and Statistics, 8-3
    - Creating Histogram and Dot Plot Overlays, 8-5
  - Calculating Sample Volume and Concentration, 8-7
  - Adjusting Compensation Settings, 8-8
  - Exporting Results, 8-9
- CHAPTER 9: Daily Shutdown, 9-1**
  - Overview, 9-1
  - Preparing the Cleaning Solution, 9-1
  - Running Daily Clean , 9-1
  - Shutting Down the Instrument, 9-2
  - Auto Shutdown [CytoFLEX LX Only], 9-3
- CHAPTER 10: Troubleshooting, 10-1**
  - Overview, 10-1
  - Precautions/Hazards, 10-1
    - Laser Related Hazards, 10-1
      - Laser Beam Hazards, 10-2
      - Laser Warning Labels, 10-3

- Hazard Labels and Locations, 10-6
  - Biohazard Label and Location, 10-6
  - Electrical Shock Hazard Label and Location, 10-7
  - Caution Labels and Location, 10-8
  - Plate Loader Hazard Labels and Location, 10-8
- Disposal Precaution, 10-9
- Troubleshooting Table, 10-9
- Backup and Restore, 10-20
  - Backup, 10-20
  - Restore, 10-23
  - Log Cleanup, 10-26

## **CHAPTER 11: Cleaning Procedures, 11-1**

- Overview, 11-1
- Routine Cleaning, 11-1
  - Daily Clean, 11-1
  - Daily Clean [With Plate Loader], 11-5
  - Cleaning the Sample Station, 11-7
    - Cleaning the Sample Probe, 11-8
  - Deep Clean Procedure, 11-9
  - Cleaning the 4 L Sheath Fluid Container, 11-11
  - Cleaning the 4 L Waste Container, 11-12
- Nonscheduled Cleaning, 11-14
  - Surface Cleaning and Disinfection, 11-14
  - Preparing the Instrument for Transport or Storage, 11-15

## **CHAPTER 12: Replacement/Adjustment Procedures, 12-1**

- Overview, 12-1
- Routine Replacement/Adjustment, 12-2
  - Front Cover Removal and Reinstallation, 12-2
    - Removal, 12-2
    - Reinstallation, 12-3
  - Right-Side Cover Removal and Reinstallation, 12-4
    - Removal, 12-4
    - Reinstallation, 12-5
  - Filling the 4 L Sheath Fluid Container, 12-6
  - Replacing the 10 L Sheath Fluid Cubitainer, 12-7
  - Emptying the 4 L Waste Container, 12-9
  - Emptying the 10 L Waste Cubitainer, 12-10
  - Managing the Maintenance Reminder, 12-14
  - Adding the Deep Clean Solution, 12-17
  - Replacing the Sheath Fluid Filter, 12-18
  - Unclogging the Sample Probe [With Sample Injection Mode Control Kit], 12-22
  - Unclogging the Sample Probe [Without Sample Injection Mode Control Kit], 12-31

- Replacing the Sample Probe and/or the Sample Peristaltic Pump Tubing, 12-38
- Replacing the Sample Probe Assembly [With Plate Loader], 12-48
- Changing the Sample Probe from the Single Tube Sample Station to the Plate Loader [CytoFLEX With Plate Loader], 12-54
- Changing the Sample Probe from the Plate Loader to the Single Tube Sample Station [CytoFLEX With Plate Loader], 12-59
- Inspecting the Liquid Flow Path for Leaks, 12-63
- Priming the Flow Cell, 12-64
- Replacing the Plate Holder [With Plate Loader], 12-65
- Plate Loader Module Removal and Reinstallation [With Plate Loader], 12-67
  - Removal, 12-67
  - Installation, 12-72
- Changing the Event Rate Setting, 12-77
- Nonscheduled Replacement/Adjustment, 12-78
  - Calibrating the Sample Flow Rate, 12-78
  - Calibrating the Sample Flow Rate [With Plate Loader], 12-82
  - Setting Laser Delay, 12-86
  - Replacing the Optical Filter, 12-87
  - Replacing the Fuse, 12-90
  - Replacing the Sheath Fluid Harness and/or Waste Harness, 12-91
  - Changing Sample Mixing and Backflush Settings, 12-94
  - Calibrating the Plate Position [With Plate Loader], 12-95

## **APPENDIX A: Instrument Installation, A-1**

- Overview, A-1
- Instrument Transportation and Storage, A-1
- Installation Environment Validation, A-2
  - Worktable, A-2
  - Ventilation and Cleaning, A-2
  - Power Source, A-3
  - Temperature and Humidity, A-4
  - Waste Disposal, A-4
- Unpacking the Instrument and Inspecting the Materials for Defects or Omissions [CytoFLEX], A-4
  - Installing the Instrument and Connecting the Equipment [CytoFLEX], A-5
  - Installing the Instrument and Connecting the Equipment [CytoFLEX LX], A-11
- CytExpert Software Installation Options, A-12
- Installing the Software [CytoFLEX Platform], A-12
  - Required Materials, A-13
  - Installing the CytExpert Software, A-13
  - Installing the Instrument Configuration File, A-22
  - Starting the Software, A-24

Upgrading the CytExpert Software, A-24

Reinstalling the CytExpert Software, A-29

## **APPENDIX B: CytExpert Electronic Record Management, B-1**

Overview, B-1

Software Menu, B-1

Experiment Management, B-2

    Closed File System, B-2

    Experiment Directory Management, B-3

    Folder Hierarchy Management, B-4

    Experiment Related Operations, B-5

    Importing an Experiment/Template, B-6

    Exporting an Experiment/Template, B-9

Log, B-12

    Experiment Operation Log, B-12

    System Operation Log, B-15

    User Management Operation Log, B-16

Electronic Signature, B-17

    Signing Experiments, B-17

    Rejecting Experiment, B-20

    Setting the Signature Retention Period, B-21

    Signature Setting, B-22

    Printing an Experiment Signature, B-25

User Management, B-26

    User Administration, B-26

        Logging In and Out of the Software, B-26

        Locking the Account, B-26

        Role Management, B-26

        User Management, B-26

        Account Policies, B-26

## **APPENDIX C: Sample Injection Mode Control Kit, C-1**

Overview, C-1

Performance Characteristics [With the Sample Injection Mode Control Knob], C-1

Sample Injection Mode Control Kit Components, C-2

Switching the Sample Probe from the Single Tube Sample Station to the Plate Loader [With Sample Injection Mode Control Knob], C-3

Switching the Sample Probe from the Plate Loader to the Single Tube Sample Station [With Sample Injection Mode Control Knob], C-5

## **APPENDIX D: Deep Well Plate, D-1**

Specimen Collection Plate Specifications, D-1

**APPENDIX E: Custom Optical Filters, E-1**

Overview, E-1

Installing a Custom Optical Filter, E-1

**APPENDIX F: WDM Beam Splitter, F-1**

Overview, F-1

Modifying Detector Configuration [With WDM Beam Splitter], F-4

**APPENDIX G: Good Practices for Cyber Security, G-1**

Overview, G-1

Drive Encryption, G-2

BitLocker Keys, G-2

Changing Encryption Strength Level for BitLocker, G-2

Enabling BitLocker, G-6

Backing Up Your Recovery Key, G-13

BitLocker Decryption, G-17

Suspending BitLocker Drive Encryption, G-21

Recovering Your BitLocker Key, G-23

Protection from Malware Software, G-25

Installing McAfee Application Control, G-26

Enabling McAfee Application Control, G-32

Exporting the Certificate, G-35

Importing BEC Certificate, G-45

Switching McAfee Application Control to Update Mode, G-47

Disabling McAfee Application Control, G-49

Operating System Updates, G-53

Enabling System Protection, G-53

Creating a Restore Point, G-56

Downloading Operating System Updates, G-57

Notification Options, G-58

Installing the Operating System Updates, G-59

Recovering from Failed Operating System Updates, G-61

System Hardening, G-62

Enabling Automatic Log-Off, G-62

Setting Account Lockout Policy, G-72

Setting Password Policy, G-74

Disabling Remote Access, G-77

Disabling Auto Play, G-79

Disabling Unnecessary Services, G-81

Disabling Unauthorized Applications, G-86

Enabling SMB Digitally Sign Communications, G-89

Enabling Installation Restriction, G-92

Enabling Firewall Defender, G-94

Enabling Network Time Protocol, G-96

**APPENDIX H:** Table of Hazardous Substances, H-1

Table of Hazardous Substances, H-1

Abbreviations

Beckman Coulter, Inc.

SOFTWARE END-USER LICENSE AGREEMENT

Related Documents



# Illustrations

- 1.1 Main Components [CytoFLEX Without Plate Loader], 1-2
- 1.2 Main Components [CytoFLEX LX], 1-3
- 1.3 Optical Filter Mounts, 1-5
- 1.4 Optical Filter Mount with Optical Filter, 1-5
- 1.5 Optical Filter Mount Labeled with the Band-Pass Information, 1-6
- 1.6 Optical Filter Mount (Top), 1-6
- 1.7 Fluid Containers [CytoFLEX and CytoFLEX S], 1-17
- 1.8 Fluid Cubitainers [CytoFLEX LX], 1-18
- 1.9 Fluidics Module View, 1-19
- 1.10 Fluidic Connections, 1-20
- 1.11 Sample Station with Tube Holder, 1-21
- 1.12 Sample Tube Holder Positions, 1-22
- 1.13 Standard Plate Loader [CytoFLEX Shown], 1-23
- 1.14 Plate Loader DW [CytoFLEX Shown], 1-24
- 1.15 Standard Plate Loader (Front Cover Removed), 1-25
- 1.16 Plate Loader DW (Front Cover Removed), 1-26
- 1.17 Standard Plate Holder without Groove (Standard Plate Loader), 1-27
- 1.18 Plate Holder with Groove (Plate Loader DW), 1-28
- 1.19 Plate Holder Stage (Standard Plate Loader), 1-29
- 1.20 Plate Holder Stage (Plate Loader DW), 1-29
- 1.21 Calibration Tool for 96-Well Deep Well Plate, 1-30
- 1.22 System Connections, 1-31
- 1.23 Back Cover Connections, 1-32
- 1.24 Front of Cytometer [CytoFLEX Without Plate Loader Shown], 1-32
- 1.25 System Connections, 1-33
- 1.26 Back Cover Connections, 1-34
- 1.27 Front of Cytometer, 1-34
- 1.28 Plate Loader DW Dimensions [CytoFLEX and CytoFLEX S], 1-36
- 1.29 Plate Loader DW Dimensions [CytoFLEX LX], 1-37
- 2.1 Drawing Controls Toolbar (Top of Screen), 2-10
- 2.2 QC Report Screen, 2-12

2.3	Software Menu Tree*, 2-14
2.4	QC Software Menu Tree, 2-15
2.5	User Manager (Card View), 2-23
2.6	User Manager (Grid View), 2-24
2.7	Role Manager, 2-28
2.8	Account Policies - Password Policy, 2-31
2.9	Account Policies - Account Lockout Policy, 2-32
2.10	Account Policies - Application Inactivity Policies, 2-32
2.11	Plate Type Library, 2-36
3.1	Flow Cell, 3-3
3.2	Laser Beam Shaping, 3-4
3.3	Light Path through the WDM with a Single Port, 3-5
3.4	Time vs Fluorescence plot, 3-7
6.1	CSV template, 6-6
6.2	Plate Window [CytoFLEX LX Shown], 6-9
6.3	All Gates - Example Experiment, 6-26
6.4	Circular Gating Logic - Example Experiment, 6-26
6.5	Movement - Default Setting, 6-31
6.6	Movement - Max Setting, 6-32
6.7	Extent - Default Setting, 6-32
6.8	Extent - Maximum Setting, 6-33
6.9	Laser Setting Window [CytoFLEX LX shown], 6-39
7.1	Before Compensation, 7-1
7.2	After Compensation, 7-1
7.3	Positive Population Selected from the Single-Stained Sample, 7-7
7.4	Positive and Negative Populations Without an Unstained Sample, 7-8
10.1	Laser Warning Label on the Laser Optical Bench [CytoFLEX], 10-3
10.2	Laser Warning Label on the Laser Optical Bench [CytoFLEX LX], 10-4
10.3	Laser Warning Label within the Optical Bench (Located Inside the Cytometer) [CytoFLEX and CytoFLEX S], 10-4
10.4	Laser Warning Label within the Optical Bench (Located Inside the Cytometer) [CytoFLEX LX], 10-4
10.5	Laser Warning Label on the 355-nm Laser [CytoFLEX LX], 10-5
10.6	Laser Warning Labels on the Cytometer Back Cover [CytoFLEX and CytoFLEX S], 10-5
10.7	Laser Warning Labels on the Cytometer Back Cover [CytoFLEX

- LX], 10-6
- 10.8 Biohazard Label on the 4 L Fluid Containers, 10-6
- 10.9 Biohazard Label on the 10 L Fluid Cubitainers, 10-7
- 10.10 Biohazard Label Located in the Sample Station and on the Back of the Cytometer [CytoFLEX Shown], 10-7
- 10.11 Electrical Shock Hazard Label by the Power Switch [CytoFLEX or CytoFLEX S], 10-7
- 10.12 Caution Labels [CytoFLEX or CytoFLEX S], 10-8
- 10.13 Plate Loader Hazard Labels, 10-8
- 12.1 Plate Holder Stage (Standard Plate Loader), 12-65
- 12.2 Plate Holder Stage (Plate Loader DW), 12-66
- 12.3 Removing the Tubings from the Fluidics Module to the Plate Loader, 12-70
- 12.4 Plate Loader Module Securing Screws, 12-71
- 12.5 Removing the Plate Loader from the Cytometer, 12-71
- 12.6 Installing the Plate Loader into the Cytometer, 12-72
- 12.7 Plate Loader Module Securing Screws, 12-73
- 12.8 Connecting the Tubings from the Fluidics Module to the Plate Loader, 12-74
- B.1 Experiment Operation Log Window, B-13
- B.2 Select Experiment Profile Window, B-14
- B.3 Print and Export Preview Window, B-15
- B.4 System Operation Log Window, B-16
- B.5 User Management Operation Log Window, B-17
- C.1 Sample Injection Mode Control Knob, C-2
- E.1 Optical Filter Mounting Fixture and Optical Filter, E-2
- F.1 WDM Beam Splitter, F-2
- F.2 CytoFLEX LX with the WDM Beam Splitter, F-4
- G.1 Choosing Drive Encryption Method and Cipher Strength, G-4
- G.2 Choosing the Encryption Level, G-5
- G.3 Checking PC Configurations, G-8
- G.4 BitLocker Encrypting the Drive, G-12
- G.5 BitLocker Successfully On, G-12
- G.6 Security Update Setup Installing, G-60
- G.7 Security Update Setup Successfully Installed, G-60
- G.8 Windows Shutdown, G-60
- G.9 Working on Completing Security Updates, G-61



# Tables

1.1	WDM Optical Filter Mount Color Codes [CytoFLEX], 1-7
1.2	WDM Optical Filter Mount Color Codes [CytoFLEX S_Violet-Blue-Yellow-Red], 1-7
1.3	WDM Optical Filter Mount Color Codes [CytoFLEX S_NUV-Violet-Blue-Red], 1-9
1.4	WDM Optical Filter Mount Color Codes [CytoFLEX S_NUV-Violet-Blue-Yellow], 1-9
1.5	WDM Optical Filter Mount Color Codes [CytoFLEX S_Violet-Blue-Red-IR], 1-11
1.6	WDM Optical Filter Mount Color Codes [CytoFLEX LX without WDM Beam splitter], 1-12
1.7	WDM Optical Filter Mount Color Codes [CytoFLEX LX with WDM Beam Splitter], 1-14
6.1	Target Power Ranges in the Laser Setting Screen, 6-39
10.1	Troubleshooting, 10-9
10.2	Troubleshooting [With Plate Loader], 10-19
D.1	Deep Well Plate [with Plate Loader DW], D-1
E.1	CytoFLEX Platform Optical Filter Specifications, E-1
F.1	Configuration Comparison, F-3
F.2	Optical Fibers with Indicator, F-4
G.1	List of Unnecessary Services, G-81
H.1	Table of Hazardous Substances Name and Concentration [CytoFLEX], H-2
H.2	Table of Hazardous Substances Name and Concentration [CytoFLEX S], H-3
H.3	Table of Hazardous Substances Name and Concentration [CytoFLEX LX], H-4



## Overview

---

This is an introductory chapter that gives a brief description of each document. It contains the following topics presented in this order:

- [How to Use Your Manual](#)
- [About this Manual](#)
- [Conventions](#)
- [Graphics](#)

## How to Use Your Manual

---

Your CytoFLEX flow cytometer system includes the manuals listed below:

- Use this **Instructions for Use** manual for information on the day-to-day operation of your CytoFLEX flow cytometer. You can find detailed step-by-step procedures for Daily Startup and Quality Control, customizing detector configuration, running samples, analyzing data, and performing Startup and Shutdown. This manual also contains physical and system specifications, safety and troubleshooting information, as well as information about what your CytoFLEX flow cytometer does and the methods guiding operation. It also contains procedures for cleaning and maintenance.
- The **CytoFLEX Setup Guide** provides instructions for unpacking and setting up the CytoFLEX flow cytometer system.
- The **CytoFLEX S Special Configuration Specifications** package insert contains the sections and procedures that are specific to the CytoFLEX S series. The CytoFLEX S Special Configuration Specifications package insert should be used along with the Instructions for Use manual.

## About this Manual

---

The information in the Instructions for Use manual is organized as follows:

### **CHAPTER 1, System Overview**

Provides information regarding the individual components of the CytoFLEX flow cytometer and the corresponding functions of these components.

### **CHAPTER 2, Using the CytExpert Software**

Provides an overview of each aspect of the software's functions.

### **CHAPTER 3, Operation Principles**

Describes how the Cytometer measures scattered light and fluorescence as cells pass through the laser beam.

### **CHAPTER 4, Daily Startup**

Provides instructions for starting your CytoFLEX flow cytometer and navigating to the sample testing standby state.

### **CHAPTER 5, Instrument Quality Control and Standardization**

Provides instructions for performing daily quality control (QC) on your CytoFLEX flow cytometer to confirm the instrument is working correctly and to ensure accurate experimental data measurement. Quality control allows you to determine whether your instrument can provide adequate signal strength and precision.

### **CHAPTER 6, Data Acquisition and Sample Analysis**

Provides instructions for operating the CytoFLEX instrument, including data acquisition, analyzing and exporting results, and manually adjusting the compensation during the acquisition and analysis.

### **CHAPTER 7, Compensation**

Describes how to create a compensation experiment and automatically calculate compensation values after acquiring the single color data. It also explains how to use these calculations for other experiments.

### **CHAPTER 8, Data Review**

Describes how to use the Analysis screen to analyze data that has already been acquired.

### **CHAPTER 9, Daily Shutdown**

Describes how to keep the instrument in optimal condition through daily cleaning during the shutdown procedure.

### **CHAPTER 10, Troubleshooting**

Describes some common problems and their solutions in a basic troubleshooting matrix.

### **CHAPTER 11, Cleaning Procedures**

Describes how to carry out certain routine and nonscheduled cleaning procedures.

### **CHAPTER 12, Replacement/Adjustment Procedures**

Describes how to carry out certain routine and nonscheduled replacement and adjustment procedures.

### **APPENDIX A, Instrument Installation**

Provides the instrument installation procedures for your CytoFLEX flow cytometer.

### **APPENDIX B, CytExpert Electronic Record Management**

Provides the instructions for using the CytExpert Electronic Record Management software option.

### **APPENDIX C, Sample Injection Mode Control Kit**

Provides the instructions for using the CytoFLEX Sample Injection Mode Control Kit.

### **APPENDIX D, Deep Well Plate**

Provides a list of deep well plates suggested for use on the Plate Loader DW.

### APPENDIX E, Custom Optical Filters

Describes how to install the custom optical filter.

### APPENDIX F, WDM Beam Splitter

Provides the instructions for using the WDM beam splitter.

### APPENDIX G, Good Practices for Cyber Security

Provides instructions for cyber security.

### APPENDIX H, Table of Hazardous Substances

Provides the table of hazardous substances with the hazardous substance name and concentration.

## Conventions

---

This document uses the following conventions:


- **Bold face** font indicates buttons or selections that appear on the workstation screen.
- The term “select” is used to indicate the following action:
  - To click with a mouse.

**NOTE** The verb “press” is reserved for mechanical buttons, such as keys on the keyboard.

- The software path to a specific function or screen appears with the greater than (>) symbol between screen options.
- Links to information in another part of the document for additional information are in blue and are underlined. To access the linked information, select the blue, underlined text.
- The information in your Instructions for Use manual applies to the CytoFLEX and CytoFLEX S instruments equipped with and without a plate loader, and the CytoFLEX LX, unless otherwise specified.

**NOTE** When information in this document only applies to the plate loader configuration, it is marked [With Plate Loader]. When information in this document only applies to the configuration not equipped with a plate loader, it is marked [Without Plate Loader]. When information in this document only applies to one instrument in the platform, it is marked either [CytoFLEX], [CytoFLEX S] or [CytoFLEX LX].

**NOTE** There are two kinds of plate loaders, the standard CytoFLEX Plate Loader and the CytoFLEX Plate Loader Deep Well (DW). The CytoFLEX Plate Loader DW (hereinafter called as Plate Loader DW) is compatible with CytoFLEX, CytoFLEX S, and CytoFLEX LX instruments. When information in this document only applies to one plate loader, it is marked either [Plate Loader DW] or [Standard Plate Loader].

- Sections that contain entirely new content are flagged with a New Section icon  at the end of the section title or chapter.
- The CytExpert Default software installation screens are shown in all instances unless otherwise specified.

**IMPORTANT** IMPORTANT is used for comments that add value to the step or procedure being performed. Following the advice in the IMPORTANT adds benefit to the performance of a piece of equipment or to a process.

**NOTE** NOTE is used to call attention to notable information that should be followed during use, or maintenance of this equipment.

## Graphics

---

All graphics, including screens and printouts, are for illustration purposes only and must not be used for any other purpose. For example, software screens that show the CytoFLEX system in the background may not depict the latest production version of the system.

## Overview

---

This chapter describes the individual components of the CytoFLEX flow cytometer and the corresponding functions of these components.

This chapter contains information on:

- [Product Description](#)
- [Main Components](#)
- [Optical Components](#)
- [Fluidics System](#)
- [Sample Station](#)
- [Plate Loader Components](#)
- [System Configuration](#)
- [Consumables and Supplies](#)
- [Instrument Specifications](#)
- [Performance Characteristics](#)
- [Reagent Limitations](#)

## Product Description

---

The CytoFLEX and CytoFLEX LX flow cytometers are used for the qualitative and quantitative measurement of biological and physical properties of cells and other particles. These properties are measured when the cells pass through one or multiple laser beams in a single-file. The CytoFLEX flow cytometer can perform up to 13 color marker analysis. The system can be ordered in various configurations. The CytoFLEX S may be ordered in various configurations from 2 lasers, 4 colors to a maximum of 4 lasers, 13 colors. The CytoFLEX LX flow cytometer can perform up to 21 color marker analysis. The system can be ordered in various configurations from a 4 laser, 14 colors, to a maximum of 6 lasers, 21 colors. Many of the configurations can be upgraded in the field. For Research Use Only. Not for use in diagnostics procedures.

**NOTE** A CytoFLEX instrument cannot be upgraded to a CytoFLEX S cytometer.

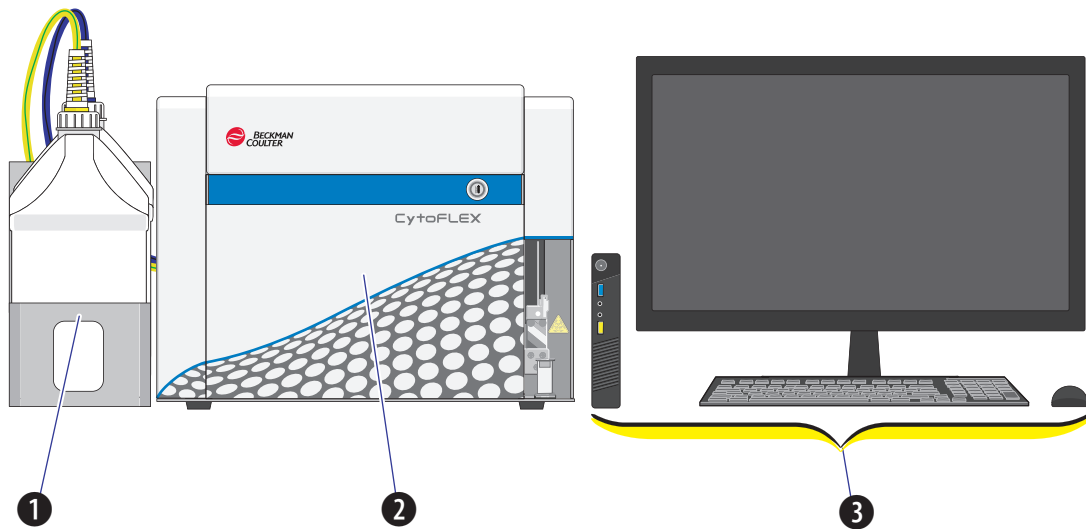
## Main Components



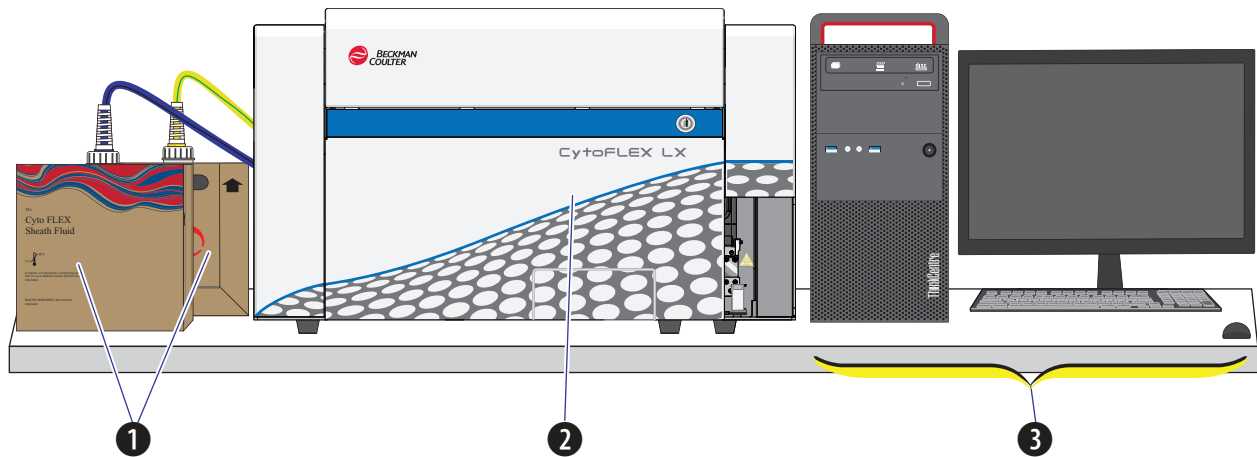
**Risk of instrument damage and/or instrument stability. Do not place any objects on top of the instrument, as this could cause warping of the top cover or affect the stability of the optical path.**

The instrument consists of three main components: Fluid Containers/Cubitainers, Cytometer, and the Workstation.

**Figure 1.1** Main Components [CytoFLEX Without Plate Loader]



- 1. Fluid Containers.** Accommodates sheath fluid and waste liquids as required for operation of the instrument.
- 2. Cytometer.** Provides signal generation and collection.
- 3. Workstation.** Displays the content of the workstation and data generated by the Cytometer.

**Figure 1.2** Main Components [CytoFLEX LX]

1. **Fluid Cubitainers.** Accommodates sheath fluid and waste liquids as required for operation of the instrument.

**NOTE** The CytoFLEX LX does not have a fluid container holder.

2. **Cytometer.** Provides signal generation and collection.

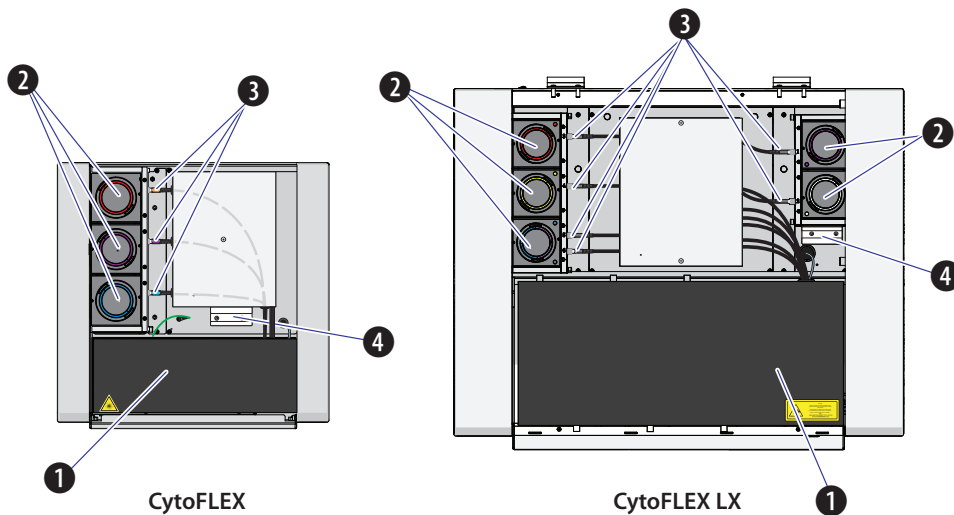
3. **Workstation.** Displays and manipulates the contents of the Workstation and displays data generated by the Cytometer.

## Optical Components

**CAUTION**

**Risk of operator injury. When operating the instrument, keep the top cover in the closed position to prevent the top cover from falling. When opening the top cover, be cautious to avoid any possible pinch points.**

The optical components are located in the upper portion of the Cytometer and are visible when the top cover is open. Three parts are included: an optical bench, detector arrays also known as wavelength division multiplexers (WDMs), and optical fibers. Optical components include equipment such as lasers and signal detectors that are used to excite, transmit, and collect optical signals.



1. **Optical bench.** Includes laser light sources, an optical beam combiner, and an integrated optics flow cell assembly. The optical bench cover is equipped with a laser interlock that turns the lasers off unless the cover is tightly closed.
2. **Wavelength division multiplexer (WDM).** Each WDM is a unique detector array that corresponds to a different laser, or in some cases two lasers. Each WDM contains optical filters and detectors for detecting channel fluorescence or scatter from a particular laser. It is necessary to ensure that the filter and software settings match for each channel.
3. **Optical fiber.** Transmits emitted fluorescence to the specific WDM.

**CAUTION**

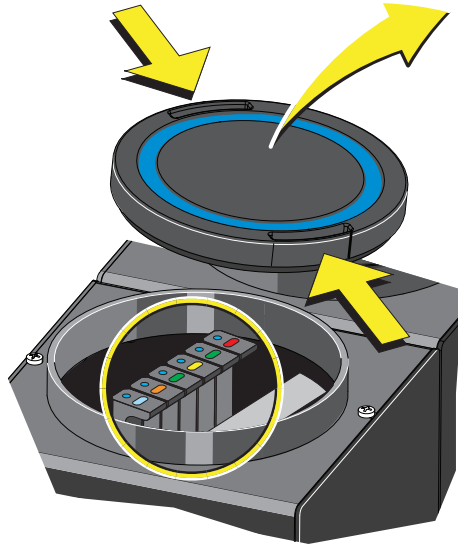
**Risk of instrument damage. Do not place sample tubes in the optical filter holder. Liquid spills can damage instrument components. Use a tube rack to hold any sample tubes.**

4. **Optical filter holder.** Securely holds additional CytoFLEX platform optical filters.

## Wavelength Division Multiplexer (WDM)

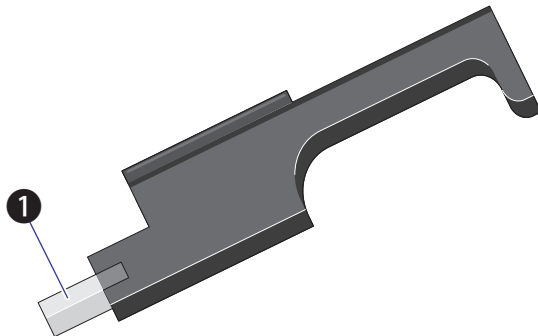
Each WDM corresponds to a different laser, or in some cases two lasers. The color of the ring on each cap corresponds to the color of the respective laser. Pressing the two release buttons on opposite edges of the cap allows you to open the WDM and replace the filters inside. See [Figure 1.3](#). All optical filters are designed to be interchangeable. Refer to [CHAPTER 12, Replacing the Optical Filter](#) to replace an optical filter.

**Figure 1.3** Optical Filter Mounts



Each optical filter mount has an optical filter glass piece. See [Figure 1.4](#).

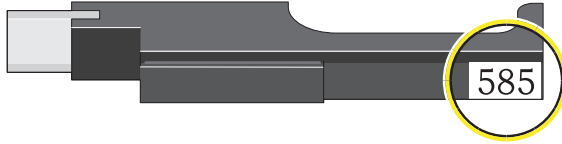
**Figure 1.4** Optical Filter Mount with Optical Filter



1. Optical filter glass piece

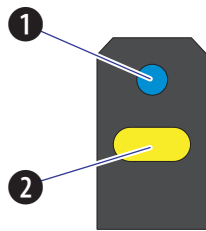
Each optical filter mount is labeled with the corresponding laser and band-pass information. See [Figure 1.5](#).



**Figure 1.5** Optical Filter Mount Labeled with the Band-Pass Information



The top of each optical filter mount has two marks. The color of the dot **(1)** indicates the color of the laser. See [Figure 1.6](#). The color of the line **(2)** indicates the wavelength range of the optical band-pass filter. See [Figure 1.6](#).

















**Figure 1.6** Optical Filter Mount (Top)








1.  . Indicates corresponding laser color: Blue indicates a 488 nm laser; Red indicates a 638 nm laser; Violet indicates a 405 nm laser; Yellow indicates a 561 nm laser; Pink indicates a 808 nm laser; White indicates either 375 nm or 355 nm.
2.  . Indicates the band-pass wavelength ranges; the midpoint of the band-pass is indicated numerically on the lateral side of the mount.

Band-pass filters are used to transmit fluorescence within a specific range of wavelength. These ranges are designed to measure fluorescence from fluorochromes such as those listed in [Table 1.1](#). (with red and violet laser upgrades installed). You can change the optical filters according to your detector configuration. There is no need to realign the optical system when the filters are changed.













**Table 1.1** WDM Optical Filter Mount Color Codes [CytoFLEX]

Lasers	Fluorescent Channel	CytoFLEX Channel Names	Commonly Used Fluorescent Dyes
 405 nm	 450/45 BP	V450	Pacific Blue dye, V450, eFluor 450, BV421
	 525/40 BP	V525	Krome Orange, AmCyan, V500, BV510
	 610/20 BP	V610	BV605, Qdot 605
	 660/10 BP	V660	BV650, Qdot 655
	 780/60 BP	V780	BV785, Qdot 800
 488 nm	 525/40 BP	B525	FITC, Alexa Fluor 488, CFSE, Fluo-3
	 585/42 BP	B585	PE, PI
	 610/20 BP	B610	ECD, PE-Texas Red, PE-CF594, PI
	 690/50 BP	B690	PC5.5, PC5, PerCP, PerCP-Cy5.5, PI, DRAQ7
	 780/60 BP	R780	PC7, DRAQ7
 638 nm	 660/10 BP	R660	APC, Alexa Fluor 647, eFluor 660, Cy5
	 712/25 BP	R712	APC-A700, Alexa Fluor 700, Cy5.5, DRAQ7
	 780/60 BP	R780	APC-A750, APC-Cy7, APC-H7, APC- eFluor 780, DRAQ7







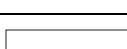



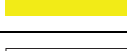
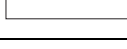





**Table 1.2** WDM Optical Filter Mount Color Codes [CytoFLEX S\_Violet-Blue-Yellow-Red]

Lasers	Fluorescent Channel	CytoFLEX Channel Names	Commonly Used Fluorescent Dyes
 405 nm	 450/45 BP	V450	Pacific Blue dye, V450, eFluor 450, BV421
	 525/40 BP	V525	Krome Orange, AmCyan, V500, BV510
	 610/20 BP	V610	BV605, Qdot 605
	 660/10 BP	V660	BV650, Qdot 655




**Table 1.2** WDM Optical Filter Mount Color Codes [CytoFLEX S\_Violet-Blue-Yellow-Red] (Continued)

Lasers	Fluorescent Channel	CytoFLEX Channel Names	Commonly Used Fluorescent Dyes
 488 nm	 525/40 BP	B525	FITC, Alexa Fluor 488, CFSE, Fluo-3
	 690/50 BP	B690	PC5.5, PC5, PerCP, PerCP-Cy5.5, PI, DRAQ7
 561 nm	 610/20 BP	Y610	ECD, mCherry, PE-CF594
	 585/42 BP	Y585	PE, DsRed
	 690/50 BP	Y690	PC5.5, PC5, PI, DRAQ7
	 780/60 BP	Y780	PC7, DRAQ7
 638 nm	 660/10 BP	R660	APC, Alexa Fluor 647, eFluor 660, Cy5
	 712/25 BP	R712	APC-A700, Alexa Fluor 700, Cy5.5, DRAQ7
	 780/60 BP	R780	APC-A750, APC-Cy7, APC-H7, APC- eFluor 780, DRAQ7














**Table 1.3** WDM Optical Filter Mount Color Codes [CytoFLEX S\_NUV-Violet-Blue-Red]

Lasers	Fluorescent Channel	CytoFLEX Channel Names	Commonly Used Fluorescent Dyes
 375 nm	 450/45 BP	N450	BUV395, DAPI
	 675/30 BP	N675	Hoescht Red, BUV661
 405 nm	 450/45 BP	V450	Pacific Blue dye, V450, eFluor 450, BV421
	 525/40 BP	V525	Krome Orange, AmCyan, V500, BV510
	 610/20 BP	V610	BV605, Qdot 605
 488 nm	 525/40 BP	B525	FITC, Alexa Fluor 488, CFSE, Fluo-3
	 585/42 BP	B585	PE, PI
	 610/20 BP	B610	ECD, PE-Texas Red, PE-CF594, PI
	 690/50 BP	B690	PC5.5, PC5, PerCP, PerCP-Cy5.5, PI, DRAQ7
	 780/60 BP	B780	PC7, DRAQ7
 638 nm	 712/25 BP	R712	APC-A700, Alexa Fluor 700, Cy5.5, DRAQ7
	 780/60 BP	R780	APC-A750, APC-Cy7, APC-H7, APC- eFluor 780, DRAQ7
	 660/10 BP	R660	APC, Alexa Fluor 647, eFluor 660, Cy5




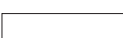












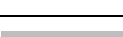
**Table 1.4** WDM Optical Filter Mount Color Codes [CytoFLEX S\_NUV-Violet-Blue-Yellow]

Lasers	Fluorescent Channel	CytoFLEX Channel Names	Commonly Used Fluorescent Dyes
 375 nm	 450/45 BP	N450	BUV395, DAPI
	 675/30 BP	N675	Hoescht Red, BUV661

**Table 1.4** WDM Optical Filter Mount Color Codes [CytoFLEX S\_NUV-Violet-Blue-Yellow] (Continued)

Lasers	Fluorescent Channel	CytoFLEX Channel Names	Commonly Used Fluorescent Dyes
 405 nm	 450/45 BP	V450	Pacific Blue dye, V450, eFluor 450, BV421
	 525/40 BP	V525	Krome Orange, AmCyan, V500, BV510
	 610/20 BP	V610	BV605, Qdot 605
	 660/10 BP	V660	BV650, Qdot 655
 488 nm	 525/40 BP	B525	FITC, Alexa Fluor 488, CFSE, Fluo-3
	 690/50 BP	B690	PC5.5, PC5, PerCP, PerCP-Cy5.5, PI, DRAQ7
 561 nm	 610/20 BP	Y610	ECD, mCherry, PE-CF594
	 585/42 BP	Y585	PE, DsRed
	 690/50 BP	Y690	PC5.5, PC5, PI, DRAQ7
	 780/60 BP	Y780	PC7, DRAQ7


















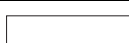




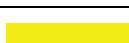


**Table 1.5** WDM Optical Filter Mount Color Codes [CytoFLEX S\_Violet-Blue-Red-IR]

Lasers	Fluorescent Channel	CytoFLEX Channel Names	Commonly Used Fluorescent Dyes
 405 nm	 450/45 BP	V450	Pacific Blue dye, V450, eFluor 450, BV421
	 525/40 BP	V525	Krome Orange, AmCyan, V500, BV510
	 610/20 BP	V610	BV605, Qdot 605
	 660/10 BP	V660	BV650, Qdot 655
 488 nm	 525/40 BP	B525	FITC, Alexa Fluor 488, CFSE, Fluo-3
	 585/42 BP	B585	PE, PI
	 690/50 BP	B690	PC5.5, PC5, PerCP, PerCP-Cy5.5, PI, DRAQ7
	 763/43 BP	B763	PC7, DRAQ7
 638 nm	 660/10 BP	R660	APC, Alexa Fluor 647, eFluor 660, Cy5
	 712/25 BP	R712	APC-A700, Alexa Fluor 700, Cy5.5, DRAQ7
	 763/43 BP	R763	APC-A750, APC-Cy7, APC-H7, APC- eFluor 780, DRAQ7
 808 nm	 840/20 BP	I840	Alexa Fluor 790
	 885/40 BP	I885	PromoFluor-840, IR fixable viability dye








**NOTE** The CytoFLEX and CytoFLEX S have the following additional BP filters supplied within the respective WDM:

- 405/10 BP
- 638/6 BP
- 561/6 BP
- 488/8 BP

**Table 1.6** WDM Optical Filter Mount Color Codes [CytoFLEX LX without WDM Beam splitter]

Lasers	Fluorescent Channel	CytoFLEX Channel Names	Commonly Used Fluorescent Dyes
 355 nm	 405/30 BP	U405	BUV395
	 525/40 BP	U525	BUV496
	 675/30 BP	U675	Hoescht Red, BUV661
	 450/45 BP	N/A	DAPI
 375 nm	 450/45 BP	N450	BUV395, DAPI
	 525/40 BP	N525	BUV496
	 675/30 BP	N675	Hoescht Red, BUV661
 405 nm	 450/45 BP	V450	Pacific Blue dye, V450, eFluor 450, BV421
	 525/40 BP	V525	Krome Orange, AmCyan, V500, BV510
	 610/20 BP	V610	BV605, Qdot 605
	 660/10 BP	V660	BV650, Qdot 655
	 763/43 BP	V763	BV785, Qdot 800
 488 nm	 525/40 BP	B525	FITC, Alexa Fluor 488, CFSE, Fluo-3
	 610/20 BP	B610	ECD, PE-Texas Red, PE-CF594, PI
	 690/50 BP	B690	PC5.5, PC5, PerCP, PerCP-Cy5.5, PI, DRAQ7
 561 nm	 610/20 BP	Y610	mCherry, ECD, PE-CF594
	 763/43 BP	Y763	PC7
	 585/42 BP	Y585	PE, DsRed
	 675/30 BP	Y675	PC5, mPlum
	 710/50 BP	Y710	PC5.5, PE-AF680















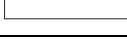




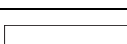

**Table 1.6** WDM Optical Filter Mount Color Codes [CytoFLEX LX without WDM Beam splitter] (Continued)

Lasers	Fluorescent Channel	CytoFLEX Channel Names	Commonly Used Fluorescent Dyes
 638 nm	 763/43 BP	R763	APC-A750, APC-Cy7, APC-H7, APC- eFluor 780, DRAQ7
	 660/10 BP	R660	APC, Alexa Fluor 647, eFluor 660, Cy5
	 712/25 BP	R712	APC-A700, Alexa Fluor 700, Cy5.5
 808 nm	 840/20 BP	I840	Alexa Fluor 790
	 885/40 BP	I885	PromoFluor-840, IR fixable viability dye











**NOTE** The CytoFLEX LX has the following additional BP filters supplied within the respective WDM:

- 405/10 BP
- 638/6 BP
- 561/6 BP
- 488/8 BP
- 450/30 BP

**Table 1.7** WDM Optical Filter Mount Color Codes [CytoFLEX LX with WDM Beam Splitter]

Lasers	Fluorescent Channel	CytoFLEX Channel Names	Commonly Used Fluorescent Dyes
 355 nm	 405/30 BP	U405	BUV395
	 525/40 BP	U525	BUV496
	 675/30 BP	U675	Hoescht Red, BUV661
	 450/45 BP	N/A	DAPI
	N/A 740/35 BP	U(S)740	BV711
	N/A 819/44 BP	U(S)819	BUV805
 375 nm	 450/45 BP	N450	BUV395, DAPI
	 525/40 BP	N525	BUV496
	 675/30 BP	N675	Hoescht Red, BUV661
	N/A 740/35 BP	N(S)740	BUV737
	N/A 819/44 BP	N(S)819	BUV805
 405 nm	 405/10 BP	VSSC	N/A
	 450/45 BP	V450	Pacific Blue dye, V450, eFluor 450, BV421
	 525/40 BP	V525	Krome Orange, AmCyan, V500, BV510
	 610/20 BP	V610	BV605, Qdot 605
	 660/10 BP	V660	BV650, Qdot 655
	 763/43 BP	V(S)763	BV785, Qdot 800
	 712/25 BP	V(S)712	BV711
 488 nm	 525/40 BP	B525	FITC, Alexa Fluor 488, CFSE, Fluo-3
	 610/20 BP	B610	ECD, PE-Texas Red, PE-CF594, PI
	 690/50 BP	B690	PC5.5, PC5, PerCP, PerCP-Cy5.5, PI, DRAQ7

**Table 1.7** WDM Optical Filter Mount Color Codes [CytoFLEX LX with WDM Beam Splitter] (Continued)

Lasers	Fluorescent Channel	CytoFLEX Channel Names	Commonly Used Fluorescent Dyes
 561 nm	 610/20 BP	Y610	mCherry, ECD, PE-CF594
	 763/43 BP	Y763	PC7
	 585/42 BP	Y585	PE, DsRed
	 675/30 BP	Y675	PC5, mPlum
	 710/50 BP	Y710	PC5.5, PE-AF680
 638 nm	 763/43 BP	R763	APC-A750, APC-Cy7, APC-H7, APC- eFluor 780, DRAQ7
	 660/10 BP	R660	APC, Alexa Fluor 647, eFluor 660, Cy5
	 712/25 BP	R712	APC-A700, Alexa Fluor 700, Cy5.5

**NOTE** The following are additional channels created when the WDM beam splitter is engaged:

- U(S)740 and U(S)819
- N(S)740 and N(S)819
- V(S)763 and V(S)712

Refer to [APPENDIX F, WDM Beam Splitter](#).

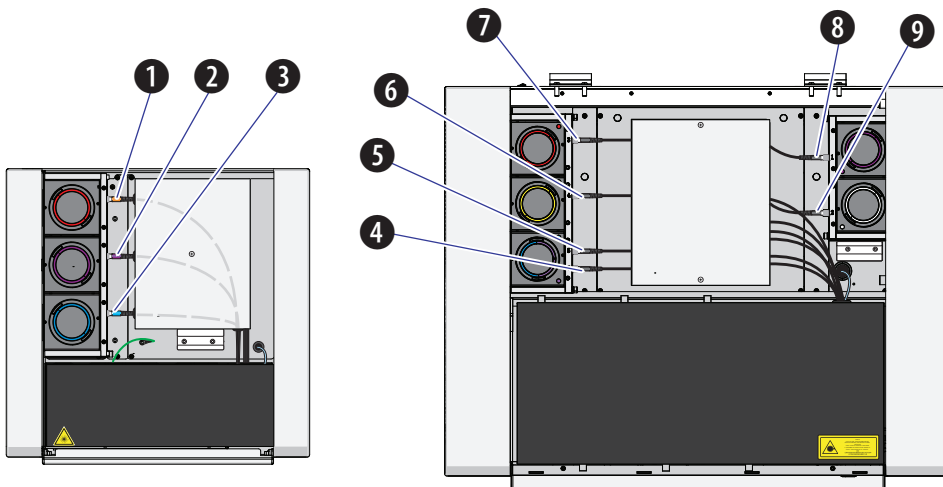
## Optical Fiber



**Risk of data integrity damage.**

- **During use, verify that the optical fibers are securely connected to the WDM. A loose connection can alter the optical path and affect fluorescence detection.**
- **Do not disconnect the fiber as this could contaminate the tip and weaken the signal.**
- **Do not kink the optical fibers.**

Fluorescence emitted by laser-excited fluorochromes is picked up and delivered by each optical fiber to the corresponding detector module. Each optical fiber has a colored ring on the end that connects to the WDM, indicating the color of the corresponding laser. Ensure that the correct fiber is properly connected to the corresponding WDM.



**CytoFLEX**

**CytoFLEX LX**

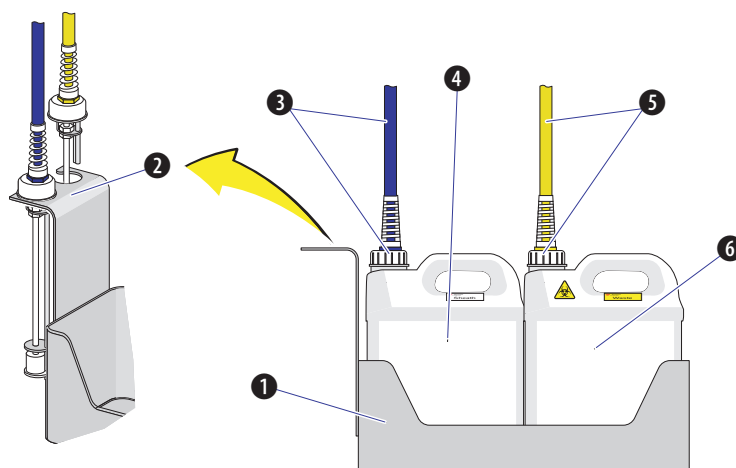
1. Red laser fiber
2. Violet laser fiber
3. Blue laser fiber
4. Infrared laser fiber
5. Blue laser fiber
6. Yellow laser fiber
7. Red laser fiber
8. Violet laser fiber
9. NUV or UV laser fiber

## Fluidics System

The fluidics system consists of two parts: the Fluid Containers/Cubitainers and the Fluidics module. The Fluidics module is located on the right side of the Cytometer. You need to open the right-side cover of the instrument (see [CHAPTER 12, Right-Side Cover Removal and Reinstallation](#)) to perform maintenance operations. The fluidics system helps to transmit the sheath fluid at a stable rate into the flow cell, forming a laminar fluidics system that ensures that the tested particles go through the detection area sequentially.

**NOTE** The 10 L sheath fluid and waste cubitainers are available from Beckman Coulter as an alternative to the 4 L Fluid Containers (refer to [Figure 1.7](#)) provided with your CytoFLEX and CytoFLEX S Flow Cytometers. [Contact us](#) to order the 10 L Sheath/Waste Line Kit. The CytoFLEX LX is only available with the 10 L sheath fluid and waste cubitainers. Refer to [Figure 1.8](#).

**Figure 1.7** Fluid Containers [CytoFLEX and CytoFLEX S]



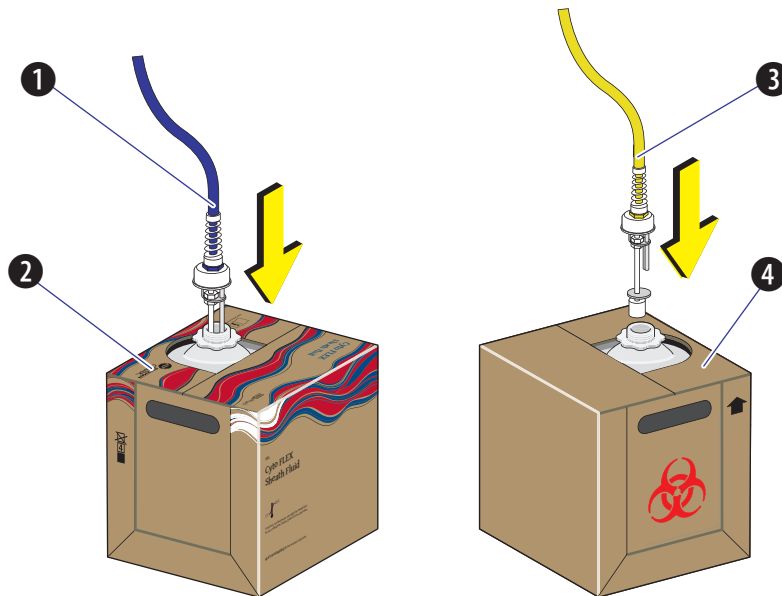
- 1. Fluid Container holder.** Holds the Fluid Containers.
- 2. Fluid sensor holder cutout.** Holds the sheath fluid harness and the waste harness when removed from their respective containers to protect the sensors from damage and/or contamination.
- 3. Sheath fluid harness.** Connects to the sheath fluid container; conveys the sheath fluid into the instrument. The sheath fluid harness includes a level sensor, sheath fluid tubing, and backflush tubing. The other end of the harness is connected to the Fluidics module in the Cytometer. When the sheath fluid container is near empty, a warning notice is transmitted to the instrument and an audible signal sounds as a warning.
- 4. Sheath fluid container.** 4 L capacity, for holding sheath fluid. Beckman Coulter recommends using CytoFLEX Sheath Fluid or a similar nonionic sheath fluid to ensure system performance.

**NOTE** The sheath fluid container must be on the same level as the Cytometer.

- 5. Waste harness.** Connects to the waste fluid container; conveys the waste fluid from the instrument to the waste container. The waste harness includes a level sensor. The other end of the harness is connected to the Fluidics module in the Cytometer. When the waste fluid container is near full, a warning notice is transmitted to the instrument and audible signal sounds as a warning.
- 6. Waste container.** 4 L capacity, for holding waste liquids. Attention to biosafety and waste labeling is required.

**NOTE** The waste container must be on the same level as the Cytometer.

Figure 1.8 Fluid Cubitainers [CytoFLEX LX]



1. **Sheath fluid harness.** Connects to the sheath fluid cubitainer; conveys the sheath fluid into the instrument. The sheath fluid harness includes a level sensor, sheath fluid tubing, and backflush tubing. The other end of the harness is connected to the Fluidics module in the Cytometer. When the sheath fluid cubitainer is near empty, a warning notice is transmitted to the instrument and an audible signal sounds as a warning.
2. **Sheath fluid cubitainer.** 10 L capacity, for holding sheath fluid. Beckman Coulter recommends using CytoFLEX Sheath Fluid or a similar nonionic sheath fluid to ensure system performance.

**NOTE** The sheath fluid cubitainer must be on the same level as the Cytometer.

3. **Waste harness.** Connects to the waste fluid cubitainer; conveys the waste fluid from the instrument to the waste cubitainer. The waste harness includes a level sensor. The other end of the harness is connected to the Fluidics module in the Cytometer. When the waste fluid cubitainer is near full, a warning notice is transmitted to the instrument and audible signal sounds as a warning.
4. **Waste cubitainer.** 10 L capacity, for holding waste liquids. Attention to biosafety and waste labeling is required.

**NOTE** The waste cubitainer must be on the same level as the Cytometer.

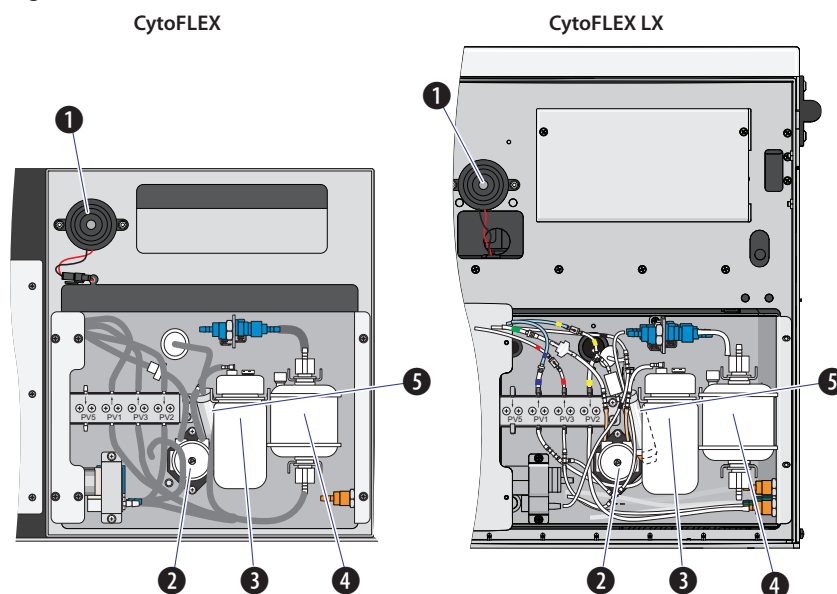
## Fluid Containers/Cubitainers

On the CytoFLEX and CytoFLEX S, two Fluid Containers are placed in the Fluid Container holder: a sheath fluid container and a waste container. See Figure 1.7. On the CytoFLEX LX, two 10 L Fluid Cubitainers are placed to the left side of the instrument: a sheath fluid cubitainer and a waste cubitainer. Each container/cubitainer cap is fitted with a harness and a level sensor. The blue harness connects to the sheath fluid container/cubitainer while the yellow harness connects to the waste container/cubitainer. The containers/cubitainers do not require pressurization. Take all necessary biosafety precautions and use proper personal protective equipment when handling the Fluid Containers/Cubitainers.

## Fluidics Module

The Fluidics module is on the right side of the Cytometer. To access it, you must first open the right-side cover. Refer to [CHAPTER 12, Right-Side Cover Removal and Reinstallation](#). Inside the module, in addition to working pumps, valves, and tubing, there is a sheath filter and a Deep Clean solution bottle. During maintenance, it may be necessary to replace the filter (see [CHAPTER 12, Replacing the Sheath Fluid Filter](#)) or to add Deep Clean solution (see [CHAPTER 12, Adding the Deep Clean Solution](#)).

**Figure 1.9** Fluidics Module View



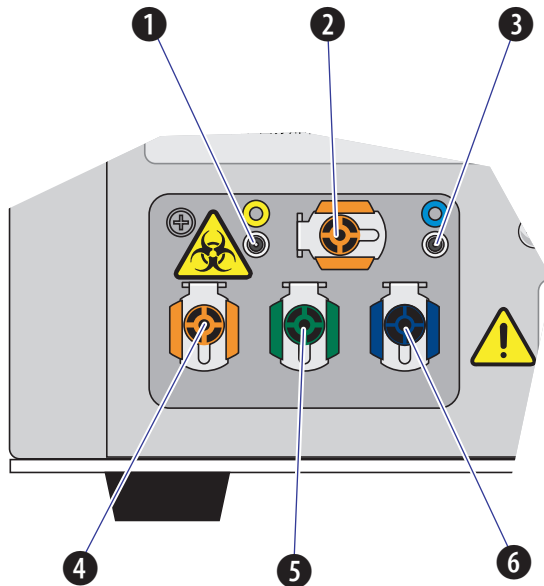
1. **Alarm.** Emits a warning sound when there is a problem with the Fluid Container/Cubitainer capacity or with the performance of certain operations.

**NOTE** When the alarm sounds, the Mute Alerter icon appears in the status bar. The alarm continues for about 30 seconds. To mute the alarm temporarily select the **Mute Alerter** in the status bar. The icon disappears when the waste container/cubitainer is emptied and/or the sheath container/cubitainer is filled/replaced.



2. **Deep Clean solution peristaltic pump.** Transfers cleaning solution to the flow cell.
3. **Deep Clean solution bottle.** Contains the diluted cleaning solution that helps to clean the flow cell.
4. **Sheath fluid filter.** 0.2  $\mu\text{m}$  filter, for filtering sheath fluid.
5. **Sheath damper.** Regulates the sheath flow rate and decreases the sheath flow fluctuation.

Figure 1.10 Fluidic Connections



1. **Waste level sensor connector.** Connects to the waste liquid sensor cable.
2. **Flow cell waste out.** Connects to the waste tubing of the wash station.
3. **Sheath fluid level sensor connector.** Connects to the sheath fluid sensor cable.
4. **Waste out.** Connects to the waste liquid tubing from the flow cell.
5. **Sheath return.** Connects to the sheath fluid tubing.

**NOTE** The sheath fluid is pressurized by a diaphragm pump. To improve pressure stability, a bypass line returns some of the sheath fluid back into the sheath fluid container/cubitainer.

6. **Sheath fluid in.** Connects to the sheath fluid tubing.

**NOTE** Use CytoFLEX Sheath Fluid or other filtered nonionic sheath fluid. Using unfiltered sheath fluid can shorten the service life of the sheath fluid filters and increase noise and debris detection.

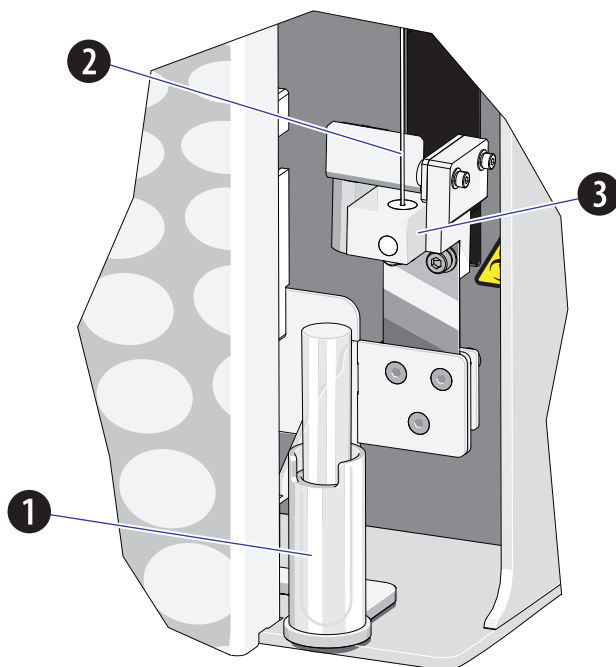
## Sample Station



### **WARNING**

Risk of biohazardous contamination and/or instrument damage. When running samples, it is important to insert the sample tube all the way down into the sample tube holder, until the bottom of the sample tube touches the base of the holder. Failing to do this could cause the sample probe to bend or break on entry. Sample tubes must not exceed 80 mm in height and the outside diameter must not exceed 13 mm.

Figure 1.11 Sample Station with Tube Holder

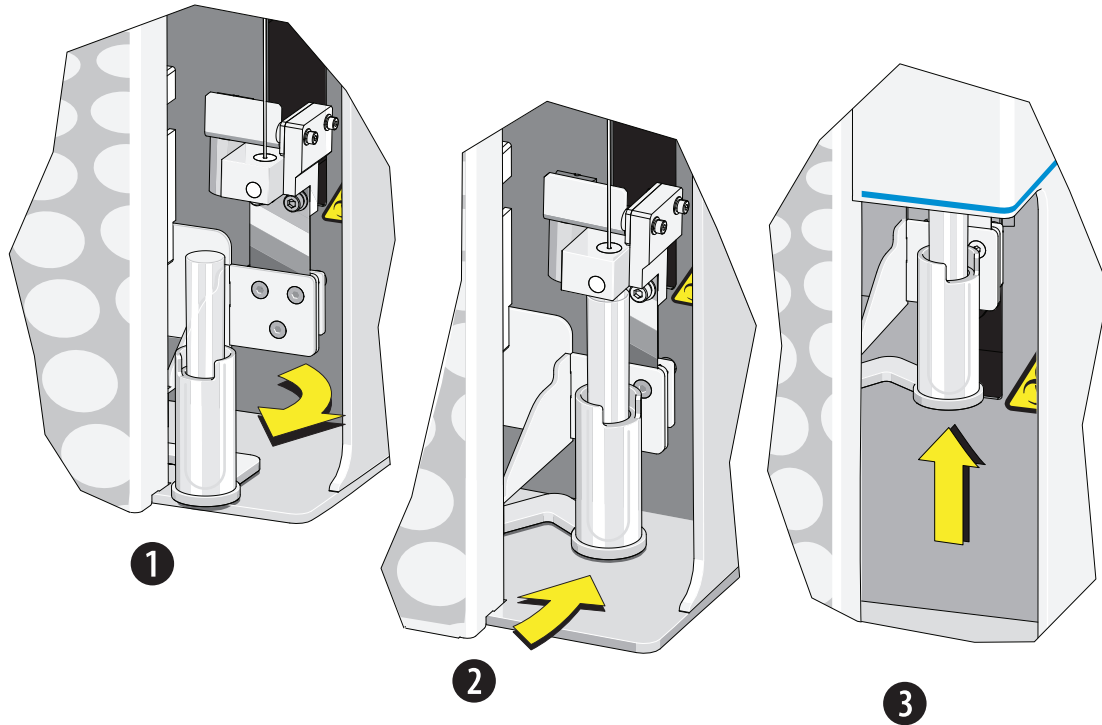


1. **Sample tube holder.** Supports sample tubes for testing, such as 12 x 75 mm, 1.5 mL, and 2 mL microtubes.
2. **Sample probe.** Draws and transfers samples into the flow cell.
3. **Wash station and mixer.** During the sampling process, samples are automatically mixed for a default time of 1 second. The sample probe is automatically cleaned when the instrument performs a backflush.

## Sample Tube Holder Positions

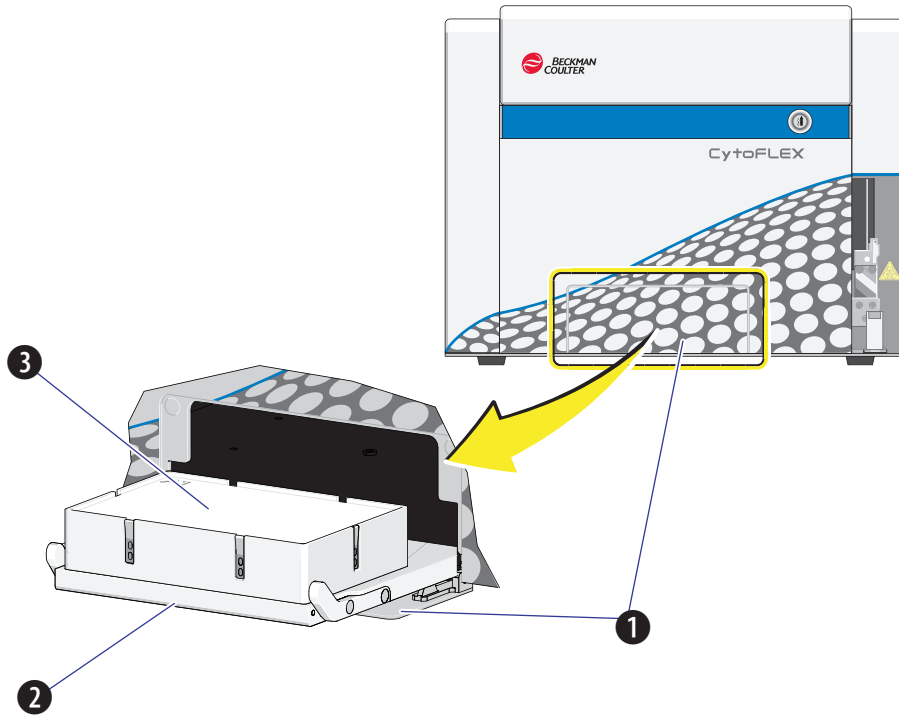
Three of the sample tube holder positions are shown in [Figure 1.12](#): sample loading position (1), standby position (2), and sample acquisition position (3). You can only distinguish the mixing position from the sample acquisition position by looking directly at the sample tube holder while the Cytometer is processing a sample. The mixing position is about 6 mm lower than the sample acquisition position.

**Figure 1.12** Sample Tube Holder Positions



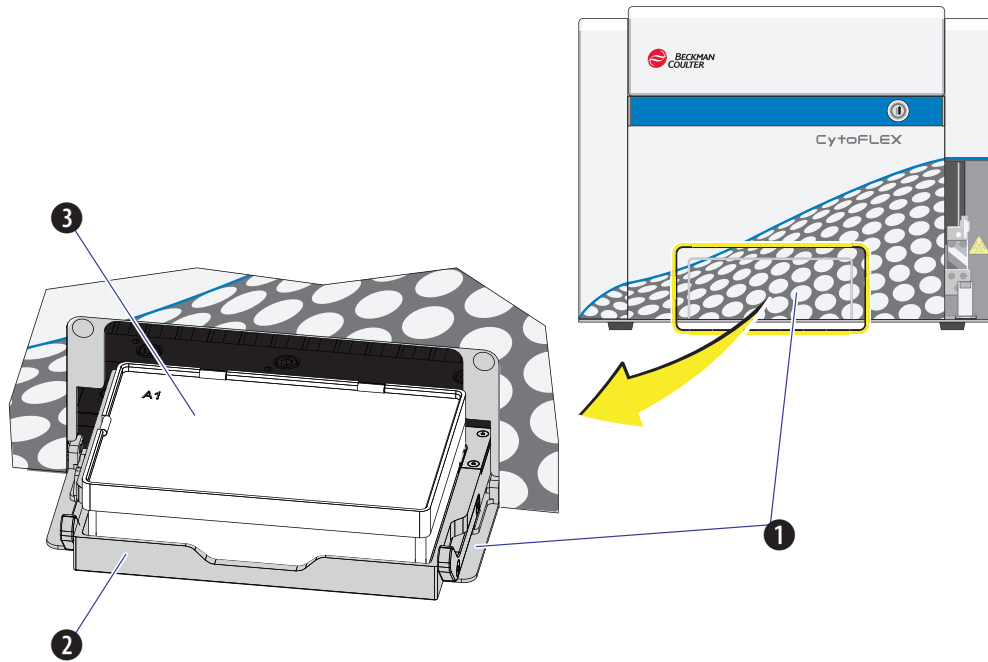
## Plate Loader Components

Figure 1.13 Standard Plate Loader [CytoFLEX Shown]



1. Plate loader door
2. Plate holder stage
3. Plate holder (removable)

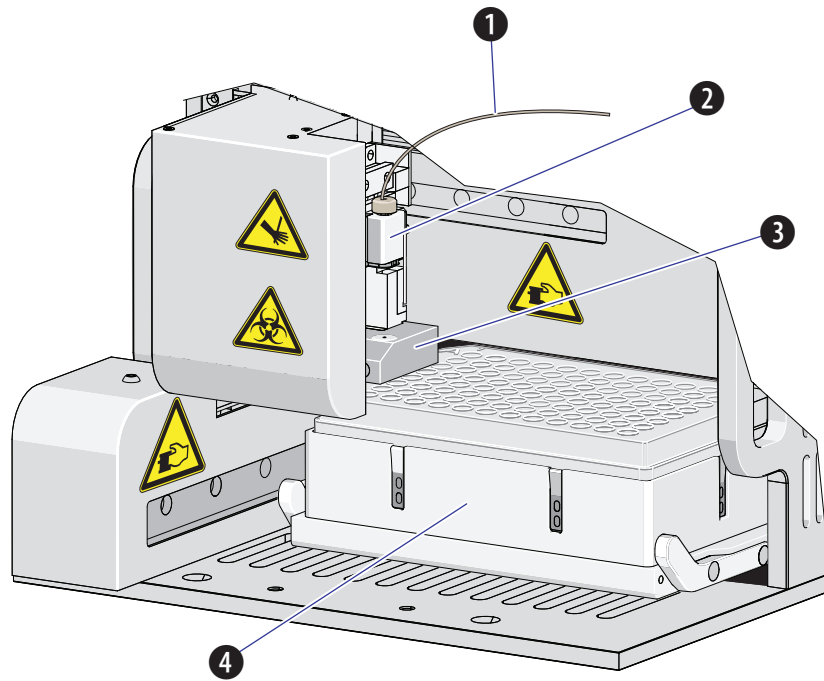
Figure 1.14 Plate Loader DW [CytoFLEX Shown]



1. Plate loader door
2. Plate holder stage
3. Plate holder (removable)

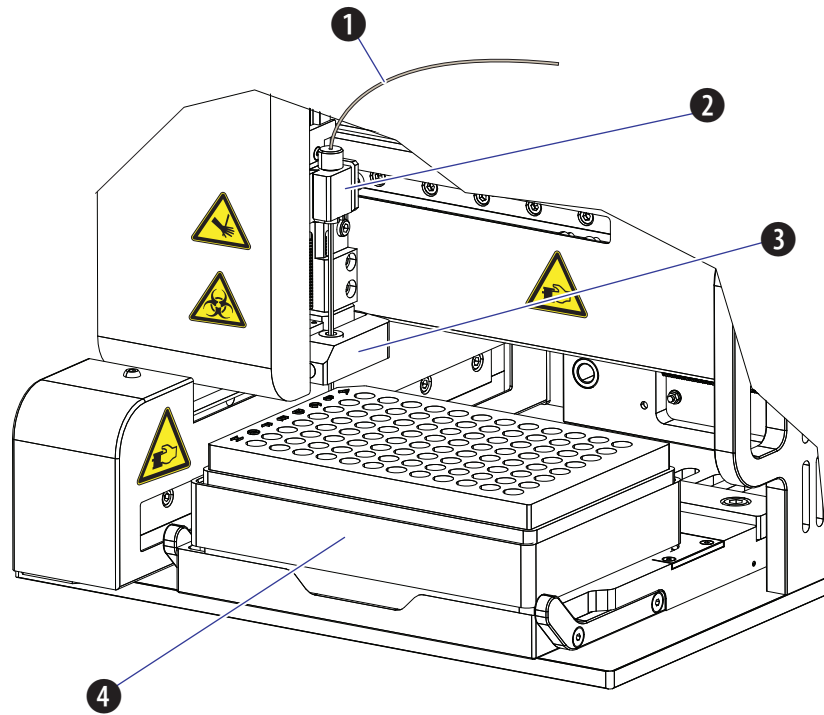
**NOTE** The Plate Loader DW supports both standard 96-well plates, and 96-well deep well plates.

Figure 1.15 Standard Plate Loader (Front Cover Removed)



1. Plate loader PEEK tubing
2. Plate loader sample probe assembly
3. Plate loader wash station
4. Plate holder

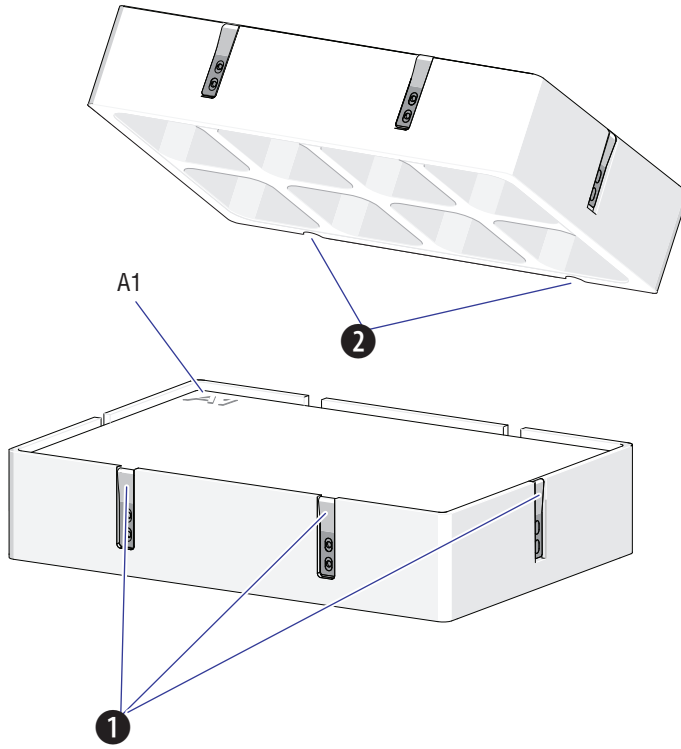
Figure 1.16 Plate Loader DW (Front Cover Removed)



1. Plate loader PEEK tubing
2. Plate loader sample probe assembly
3. Plate loader wash station
4. Plate holder

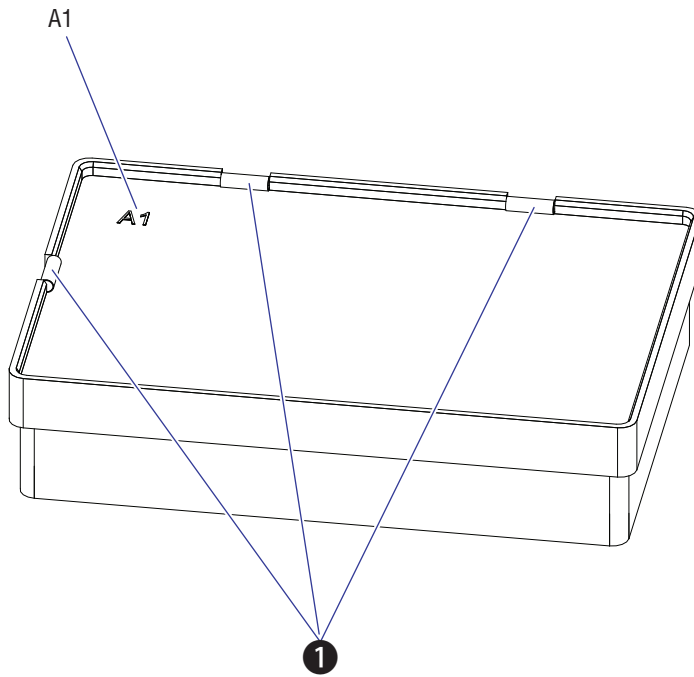
## Plate Holder Components

Figure 1.17 Standard Plate Holder without Groove (Standard Plate Loader)



1. Spring leaves to hold plate
2. Plate holder notches

Figure 1.18 Plate Holder with Groove (Plate Loader DW)

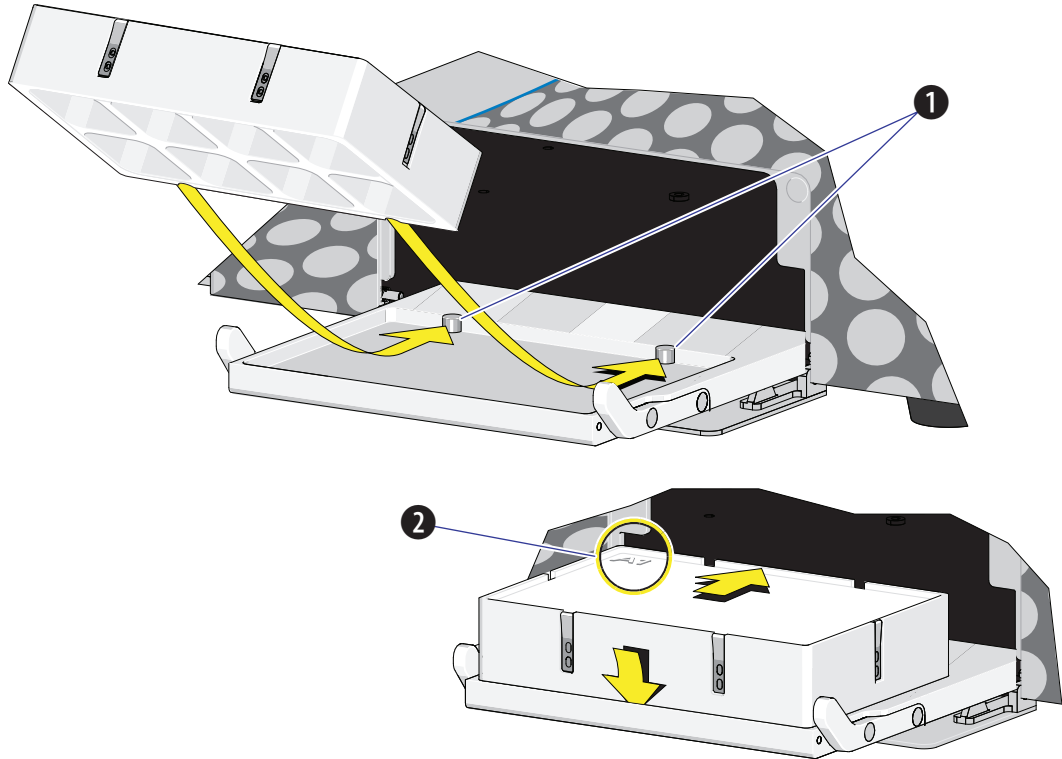


1. Spring leaves to hold plate

**NOTE** The plate holder is removable and replaceable. Refer to [CHAPTER 12, Replacing the Plate Holder \[With Plate Loader\]](#).

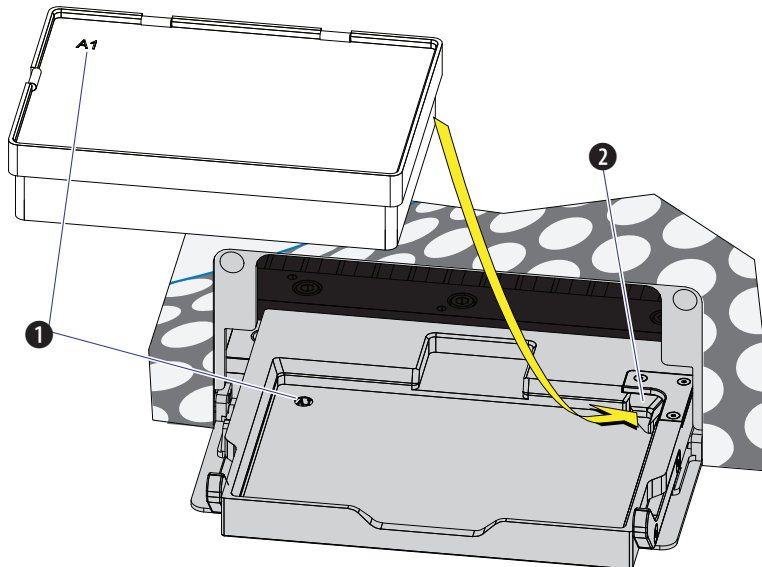
The plate holder is only used to hold standard 96-well plates. Note that 96-well deep well plates do not use a plate holder.

**Figure 1.19** Plate Holder Stage (Standard Plate Loader)



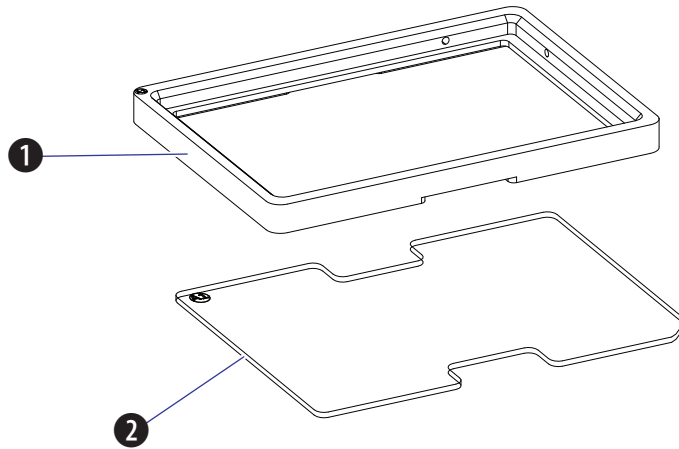
- 1. Pins
- 2. Position A1

**Figure 1.20** Plate Holder Stage (Plate Loader DW)



- 1. Position A1
- 2. Spring lock

Figure 1.21 Calibration Tool for 96-Well Deep Well Plate



1. Calibration frame
2. Transparent plate

**NOTE** The calibration frame and the transparent plate are used to assist the calibration in X-axis and Y-axis. They are delivered together with the Plate Loader DW.

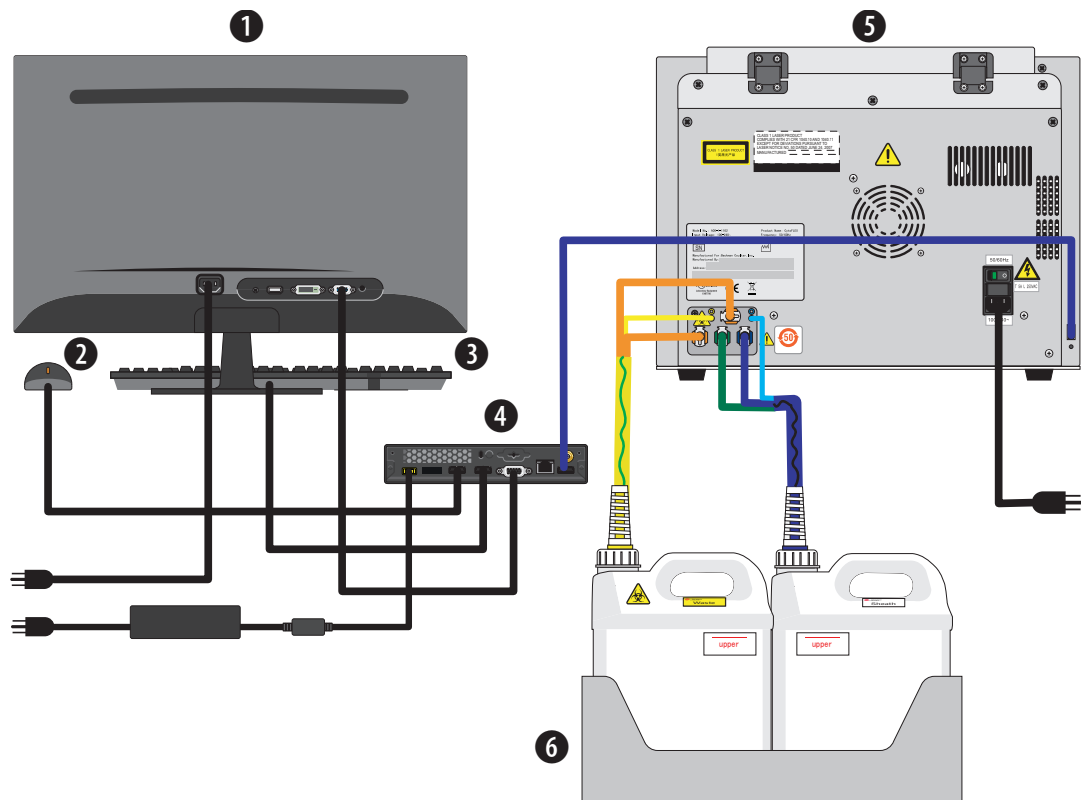
## System Configuration

**CAUTION**

Risk of data loss and/or instrument damage. Never shut off the power or disconnect a data cable while the Cytometer is in the process of performing a task. This could cause data loss or damage to the system.

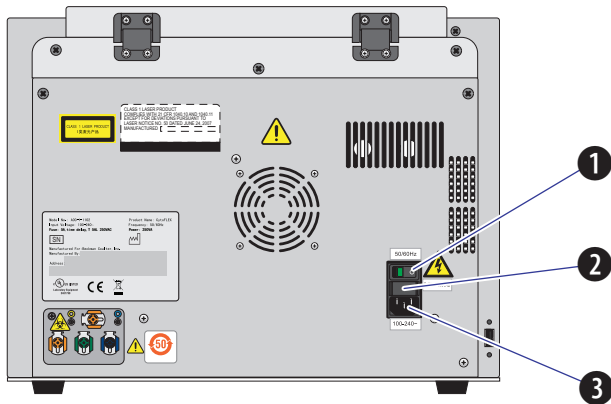
### System Configuration [CytoFLEX and CytoFLEX S]

Figure 1.22 System Connections



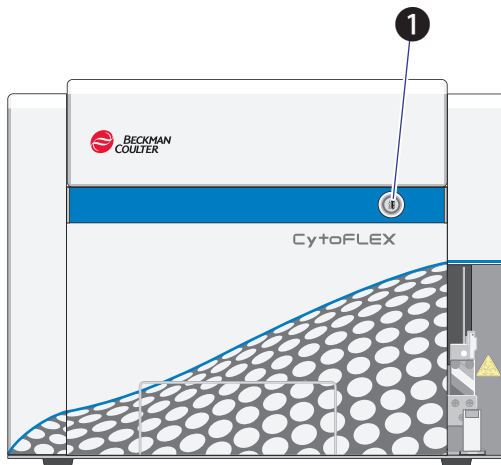
- |             |                           |
|-------------|---------------------------|
| 1. Monitor  | 4. Computer               |
| 2. Mouse    | 5. Cytometer              |
| 3. Keyboard | 6. Fluid Container holder |

Figure 1.23 Back Cover Connections



1. **Power switch.** Turns Cytometer on and off. An indicator light glows when the power is on.
2. **Fuse.** Protects the internal system from damage by high electrical current.
3. **Power line socket.** Supplies the power to the Cytometer.

Figure 1.24 Front of Cytometer [CytoFLEX Without Plate Loader Shown]



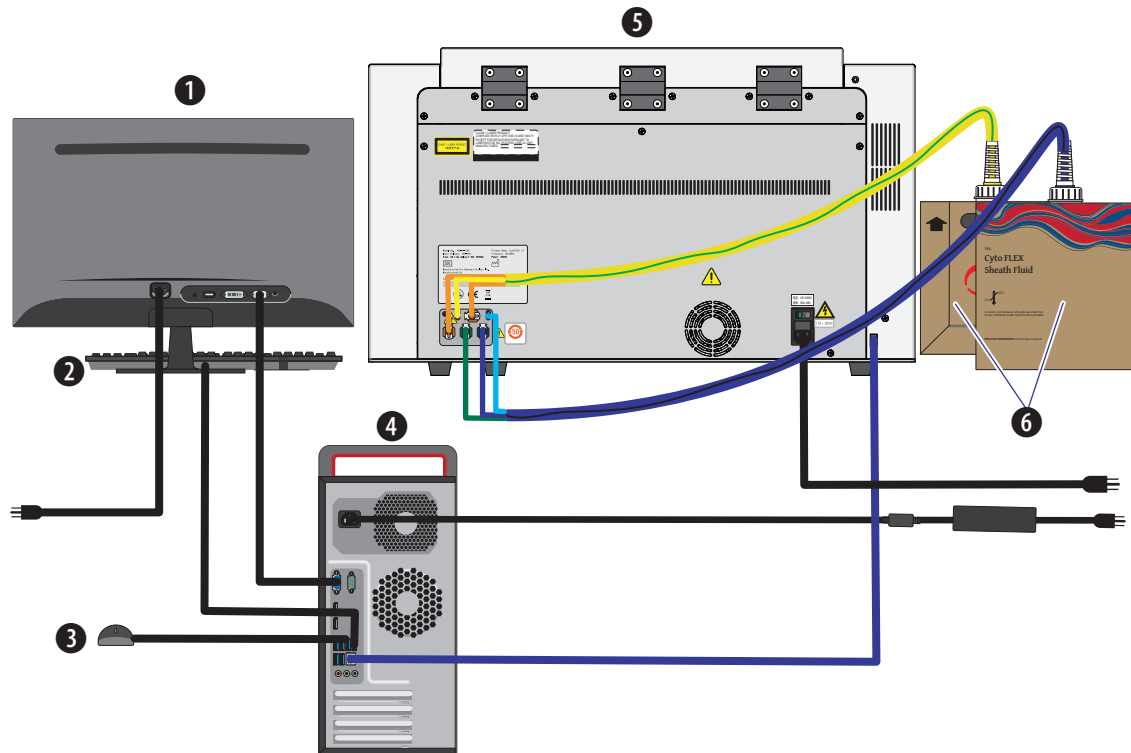
1. **Load button.** In addition to the software controls, this button can be used for automatic sample loading and data recording.

**NOTE** This function is not available in the Plate Loader sample injection mode.

## System Configuration [CytoFLEX LX]

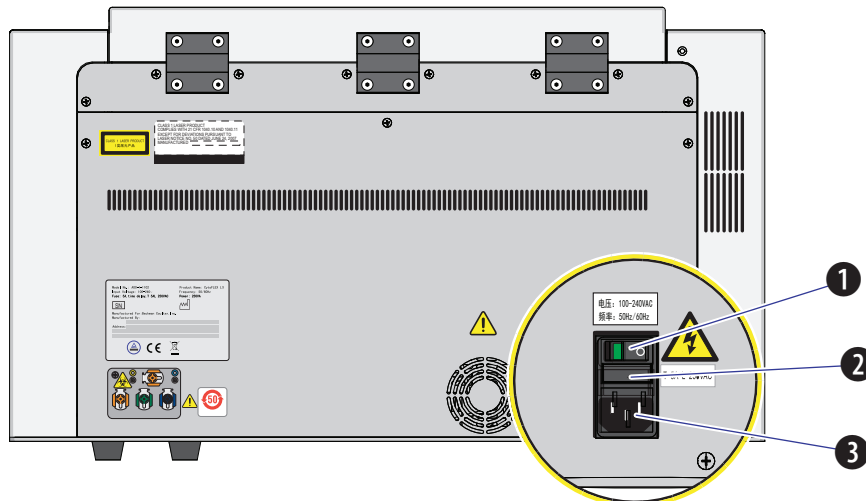
**IMPORTANT** The fluid cubitainers must be on the same level as the Cytometer. Do not place the fluid cubitainers on the floor.

**Figure 1.25** System Connections



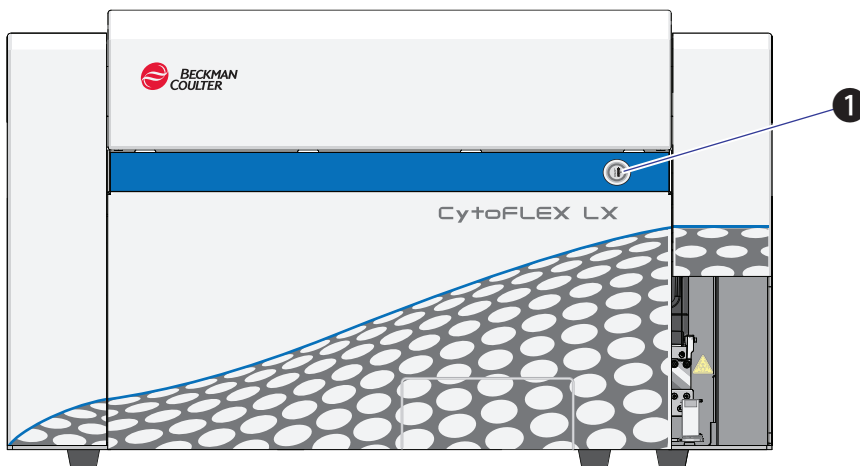
- |             |                      |
|-------------|----------------------|
| 1. Monitor  | 4. Computer          |
| 2. Keyboard | 5. Cytometer         |
| 3. Mouse    | 6. Fluid Cubitainers |

Figure 1.26 Back Cover Connections



1. **Power switch.** Turns Cytometer on and off. An indicator light glows when the power is on.
2. **Fuse.** Protects the internal system from damage by high electrical current.
3. **Power line socket.** Supplies the power to the Cytometer.

Figure 1.27 Front of Cytometer



1. **Load button.** In addition to the software controls, this button can be used for automatic sample loading and data recording.

**NOTE** This function is not available in the Plate Loader sample injection mode.

## Consumables and Supplies

---

### Reagents

The following reagents are available for the CytoFLEX, CytoFLEX S and CytoFLEX LX instrument:

#### **CytoFLEX Ready to Use Daily QC Fluorospheres**

The CytoFLEX Ready to Use Daily QC Fluorospheres are a ready to use formulation of fluorospheres that are used for QC standardization on the CytoFLEX Platform.

#### **CytoFLEX Daily QC Fluorospheres**

The CytoFLEX Daily QC Fluorospheres is a suspension of fluorescent microspheres which may be used for daily verification of the CytoFLEX flow cytometer's optical alignment and fluidics system.

**NOTE** Not for daily verification of the IR laser QC.

#### **CytoFLEX Sheath Fluid**

A nonionic, non-fluorescent, anti-microbial and azide-free sheath fluid for use on Beckman Coulter CytoFLEX flow cytometers.

#### **Contrad 70 Reagent**

Diluted 1:1 with DI water for use in the Deep Clean solution bottle.

#### **FlowClean**

For use during Daily Clean procedure for cleaning the sample lines.

The following reagents are available for the IR laser QC:

#### **CytoFLEX Daily IR QC Fluorospheres**

The CytoFLEX Daily IR QC Fluorospheres is a suspension of fluorescent microspheres which may only be used for daily verification of the CytoFLEX flow cytometer's Infrared optical alignment.

### Ordering Information

Your instrument may be upgraded to a more highly configured model. For information on specific upgrades, replacement parts, or supplies, visit:

- [www.beckman.com/supplies/cytoflex-platform-upgrades](http://www.beckman.com/supplies/cytoflex-platform-upgrades)

Otherwise, [contact us](#).

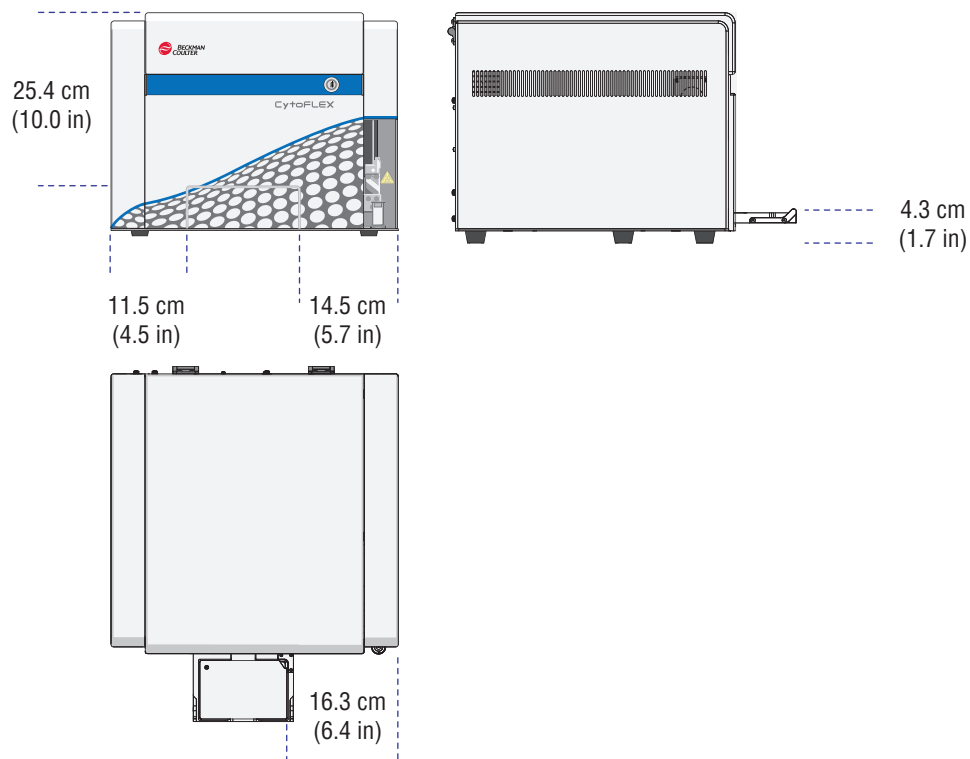
## Instrument Specifications

### Dimensions [CytoFLEX and CytoFLEX S]

Dimensions		
Instrument dimensions (Length x Width x Height)	Cytometer [With or Without Plate Loader]	42.5 cm x 42.5 cm x 34 cm
	Fluid Containers and Fluid Container holder	14 cm x 35.6 cm x 35.6 cm
Weight	Cytometer [Without Plate Loader]	23.4 kg
	Cytometer [With Standard Plate Loader]	28 kg
	Cytometer [With Plate Loader DW]	28.4 kg

Refer to [Figure 1.28](#) for the [CytoFLEX and CytoFLEX S] Plate Loader DW dimensions.

**Figure 1.28** Plate Loader DW Dimensions [CytoFLEX and CytoFLEX S]

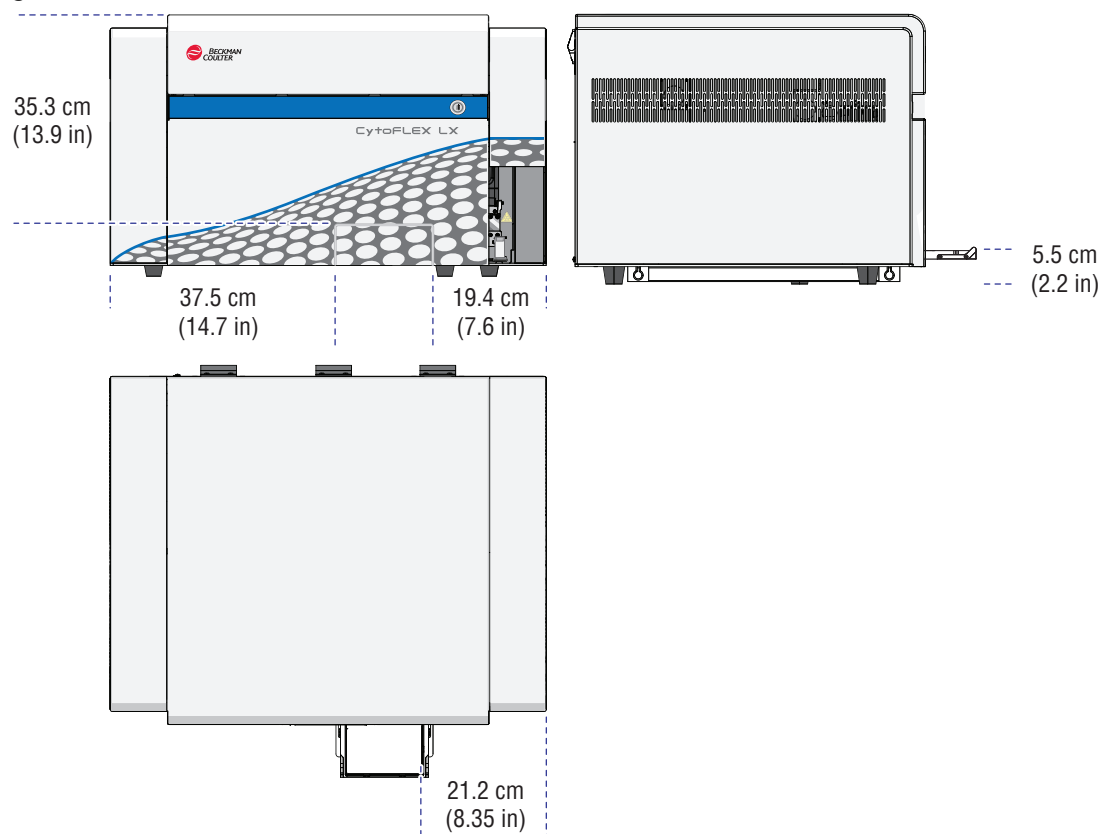


## Dimensions [CytoFLEX LX]

Dimensions		
Instrument dimensions (Length x Width x Height)	Cytometer [With or Without Plate Loader]	73.3 cm x 60.5 cm x 45.1 cm
	Fluid Cubitainers	25 cm x 25 cm x 25 cm
Weight	Cytometer [Without Plate Loader]	79 kg
	Cytometer [With Standard Plate Loader]	83.6 kg
	Cytometer [With Plate Loader DW]	84 kg

Refer to [Figure 1.29](#) for the [CytoFLEX LX] Plate Loader DW dimensions.

**Figure 1.29** Plate Loader DW Dimensions [CytoFLEX LX]



## Installation Category

Installation Category 2

## Maximum Altitude



Do not operate at an altitude greater than 2000 m (6561 ft). Beckman Coulter assumes no responsibility for any problems resulting from operating instrument at an altitude greater than 2000 m (6561 ft).

## Pollution Degree

Pollution Degree 2

## Acoustic Noise Level

Measure Level: <65 dBA

## Electrical Ratings

Voltage: 100-240 VAC, 50/60 Hz, 250 VA

## Cytometer

Optics	
<b>Excitation optics</b>	<p>The optical system is alignment free. The laser delays are automatically adjusted by the daily QC system, if required. No user intervention is required to ensure optimum system performance.</p> <p><b>CytoFLEX:</b> The system can be configured with up to three spatially-separated lasers.</p> <p><b>CytoFLEX S:</b> The system can be configured with up to four spatially-separated lasers.</p> <p><b>CytoFLEX LX:</b> The system can be configured with up to six spatially-separated lasers.</p>
<b>Emission optics</b>	<p>Patent-pending alignment-free integrated optics quartz flow cell design with &gt;1.3 NA.</p> <p>Flow Cell dimensions: 430 <math>\mu\text{m}</math> x 180 <math>\mu\text{m}</math> internal diameter.</p>

Optics		
Laser devices	Standard wavelengths	<p><b>Blue laser</b></p> <ul style="list-style-type: none"> <li>Wavelength: 488 nm, 50 mW</li> <li>Beam spot size: 5 µm x 80 µm</li> </ul> <p><b>Red laser</b></p> <ul style="list-style-type: none"> <li>Wavelength: 638 nm, 50 mW</li> <li>Beam spot size: 5 µm x 80 µm</li> </ul> <p><b>Violet laser</b></p> <ul style="list-style-type: none"> <li>Wavelength: 405 nm, 80 mW</li> <li>Beam spot size: 5 µm x 80 µm</li> </ul>
	Additional standard wavelengths [CytoFLEX S or CytoFLEX LX]	<p><b>Yellow laser</b></p> <ul style="list-style-type: none"> <li>Wavelength: 561 nm, 30 mW</li> <li>Beam spot size: 5 µm x 80 µm</li> </ul> <p><b>Ultraviolet (UV) laser</b></p> <ul style="list-style-type: none"> <li>Wavelength: 355 nm, 20 mW</li> <li>Beam spot size: 5 µm x 80 µm</li> </ul> <p><b>Near Ultraviolet (NUV) laser</b></p> <ul style="list-style-type: none"> <li>Wavelength: 375 nm, 60 mW</li> <li>Beam spot size: 5 µm x 80 µm</li> </ul> <p><b>Infrared (IR) laser</b></p> <ul style="list-style-type: none"> <li>Wavelength: 808 nm, 60 mW</li> <li>Beam spot size: 5 µm x 80 µm</li> </ul>
Forward scatter detection	Silicon photodiode with built-in 488/8 band-pass filter.	
Fluorescence and side scatter detection	Fluorescence and side scatter light collected by the objective lens is delivered by fiber optics to a patent-pending design with high performance, solid-state, high efficiency, low-noise detector array.  Reflective optics with a single transmission band-pass filter in front of each detector.	
Violet side scatter configuration (VSSC)	The system offers the ability to configure the violet laser WDM to collect side scatter to better resolve nanoparticles from noise.	

Fluidics System	
Sample flow rates	<p><b>Fixed Flow Rates:</b> 10 µL/min, 30 µL/min, 60 µL/min</p> <p><b>Custom Flow Rates:</b> 10-240 µL/min in 1 µL increments</p>
Fluid capacity	<p><b>CytoFLEX and CytoFLEX S:</b> Standard 4 L sheath fluid and waste containers; Optional 10 L sheath fluid and waste cubitainers</p> <p><b>CytoFLEX LX:</b> Standard 10 L sheath fluid and waste cubitainers</p>
Automated maintenance cycles	Initialize, system startup program, sample mix, backflush, prime, Daily Clean, Deep Clean

Fluidics System		
<b>Sample input formats</b>	<b>Single Tube Loader format</b>	5 mL (12 x 75 mm) polystyrene and polypropylene sample tubes 1.5 mL and 2 mL micro-centrifuge sample tubes
<b>Dead Volume</b>	10 µL	
<b>Minimum Sample Volume</b>	100 µL	

Fluidics System [With Standard Plate Loader]		
<b>Sample input formats</b>	<b>Plate format</b>	Flat/U/V bottom standard 96-well plate
<b>Dead volume</b>	<b>96-well flat bottom plate</b>	20 µL
	<b>96-well U bottom plate</b>	10 µL
	<b>96-well V bottom plate</b>	10 µL
<b>Minimum sample volume</b>	45 µL/well	
<b>Maximum sample volume</b>	250 µL/well	

Fluidics System [With Plate Loader DW] <sup>a</sup>		
<b>Sample input formats</b>	<b>Plate format</b>	96-well deep well plate; Flat/U/V bottom standard 96-well plate
<b>Dead volume</b>	<b>96-well deep well plate</b>	20 µL
	<b>Flat bottom standard 96-well plate</b>	20 µL
	<b>U/V bottom standard 96-well plate</b>	10 µL
<b>Minimum sample volume</b>	Standard 96-well plate: 50 µL/well Deep well plate: 200 µL/well <sup>b</sup>	
<b>Maximum sample volume</b>	Refer to the related specification of the deep well plates.	

- a. The 96-well deep well plates are only available for use if the Plate Loader DW is installed. The information below is based on the deep well plates manufactured by Beckman Coulter. Refer to [APPENDIX D, Deep Well Plate](#).
- b. To mix sample thoroughly, it is recommended to add at least 200 µL sample per well for one time.

Electronics	
<b>Signal processing</b>	7 decade data display
<b>Digital sampling rate</b>	25 MHz
<b>Signal</b>	Pulse area and height for every channel, width for one selectable channel

Data Management		
<b>Software</b>	CytExpert software	
<b>Language</b>	English and Chinese	
<b>FCS format</b>	FCS 3.0	
<b>Operating system</b>	Windows 10 professional 64 bit or Windows 10 Enterprise LTSC 2019 64 bit	
<b>Minimum workstation/ computer requirements [CytoFLEX/ CytoFLEX S]</b>	<b>Processor</b>	7th Gen Intel Core i3 (3MB Cache, 3.4 GHz)
	<b>Memory</b>	8 GB RAM
	<b>Storage</b>	500 GB
	<b>Ethernet</b>	Ethernet LAN 10/100/1000 or equivalent
	<b>USB</b>	4 USB 2.0 and above ports
<b>Minimum workstation/ computer requirements [CytoFLEX LX]</b>	<b>Processor</b>	4th Generation Intel Core i7 (8MB cache 4.0 GHz)
	<b>Memory</b>	8 GB RAM
	<b>Storage</b>	500 GB
	<b>Ethernet</b>	Integrated 10M/100M/1000M Gigabyte
	<b>USB</b>	4 USB 2.0 and above ports
<b>Compensation</b>	Full matrix compensation, manual and automatic. Novel Compensation Library for storage of spillover values of dyes to easily determine the correct compensation matrix with new gain settings.	

## Performance Characteristics

### Performance Characteristics [CytoFLEX and CytoFLEX S]

Performance		
<b>Sensitivity</b>	<b>MESF</b>	FITC: <30 molecules of equivalent soluble fluorochrome (MESF-FITC) PE: <10 molecules of equivalent soluble fluorochrome (MESF-PE) APC: <25 molecules of equivalent soluble fluorochrome (MESF-APC)
<b>Fluorescence resolution</b>	rCV <3% The CytoFLEX Flow cytometer is capable of achieving <3% rCV. Using CytoFLEX Daily QC Fluorospheres, CytoFLEX Ready to Use Daily QC Fluorospheres or Daily IR QC Fluorospheres (for 808 nm Laser) for daily QC, the pass criteria is ≤5% for the Violet, Blue, Yellow, and Red lasers while the pass criteria is ≤7% for NUV, and IR lasers.	
<b>Blue side scatter resolution</b>	<300 nm	

Performance	
<b>Violet side scatter resolution</b>	80 nm relative to polystyrene particles
<b>Forward and side scatter resolution</b>	Scatter performance is optimized for resolving lymphocytes, monocytes, and granulocytes as well as nanoparticles.
<b>Carryover</b>	<b>Single Tube Loader format</b> ≤1.0%
<b>Signal acquisition speed</b>	30,000 particles/second with 15 parameters

Performance [With Standard Plate Loader]	
<b>Carryover</b>	<b>Plate Loader format</b> ≤1.0%
<b>Throughput [With Plate Loader]<sup>a</sup></b>	10 second acquisition without mixing or backflush: <32 min.
	10 second acquisition with 3 second mixing and 3 second backflush: <45 min.

a. This performance characteristic is different if you have the Sample Injection Mode Control Kit installed on your CytoFLEX cytometer. Refer to [APPENDIX C, Sample Injection Mode Control Kit](#).

Performance [With Plate Loader DW]	
<b>Carryover</b>	<b>Plate Loader format</b> ≤1.0%
<b>Throughput [With Plate Loader DW]<sup>a</sup></b>	Standard 96-well plate, 10 second acquisition without mixing or backflush: <36 min.
	Deep-well 96-well plate, 10 second acquisition without mixing or backflush: <37 min
	Standard 96-well plate, 10 second acquisition with 5 second mixing and 4 second backflush: <54 min.
	Deep-well 96-well plate, 10 second acquisition with 10 second mixing and 4 second backflush: <64 min.

a. The Plate Loader DW is equipped with the Sample Injection Mode Control Kit. Refer to [APPENDIX C, Sample Injection Mode Control Kit](#).

## Performance Characteristics [CytoFLEX LX]

Performance		
<b>Sensitivity</b>	<b>MESF</b>	FITC: <30 molecules of equivalent soluble fluorochrome (MESF-FITC) PE: <10 molecules of equivalent soluble fluorochrome (MESF-PE) APC: <25 molecules of equivalent soluble fluorochrome (MESF-APC)
<b>Fluorescence resolution</b>	rCV <3% The CytoFLEX LX Flow cytometer is capable of achieving <3% rCV. Using CytoFLEX Daily QC Fluorospheres, CytoFLEX Ready to Use Daily QC Fluorospheres, or Daily IR QC Fluorospheres (for 808 nm Laser) for daily QC, the pass criteria is ≤5% for the Violet, Blue, Yellow, and Red lasers while the pass criteria is ≤7% for NUV, UV and IR lasers.	
<b>Blue side scatter resolution</b>	<300 nm	
<b>Violet side scatter resolution</b>	80 nm relative to polystyrene particles	
<b>Forward and side scatter resolution</b>	Scatter performance is optimized for resolving lymphocytes, monocytes, and granulocytes as well as nanoparticles.	
<b>Carryover</b>	<b>Single Tube Loader format</b>	≤1.0%
<b>Signal acquisition speed</b>	30,000 particles/second with 23 parameters	

Performance [With Standard Plate Loader]		
<b>Carryover</b>	<b>Plate Loader format</b>	≤1.0%
<b>Throughput [With Standard Plate Loader]<sup>a</sup></b>	10 second acquisition without mixing or backflush: <34 min.	
	10 second acquisition with 3 second mixing and 3 second backflush: < 47 min.	

a. This performance characteristic is different if you have the Sample Injection Mode Control Kit installed on your CytoFLEX LX flow cytometer. Refer to [APPENDIX C, Sample Injection Mode Control Kit](#).

Performance [With Plate Loader DW]		
<b>Carryover</b>	<b>Plate Loader format</b>	≤1.0%
<b>Throughput [With Plate Loader DW]<sup>a</sup></b>	Standard 96-well plate, 10 second acquisition without mixing or backflush: <39 min.	
	Deep-well 96-well plate, 10 second acquisition without mixing or backflush: <40 min	
	Standard 96-well plate, 10 second acquisition with 5 second mixing and 6 second backflush: <60 min.	
	Deep-well 96-well plate, 10 second acquisition with 10 second mixing and 6 second backflush: <69 min.	

a. The Plate Loader DW is equipped with the Sample Injection Mode Control Kit. Refer to [APPENDIX C, Sample Injection Mode Control Kit](#).

## Reagent Limitations

---

- Only use nonionic sheath fluid with antimicrobial, like CytoFLEX Sheath Fluid. Do not use sheath fluid containing electrolytes.
- Do not use organic solvents in the system.

## Material Safety Data Sheets (SDS/MSDS)

---

To obtain an SDS or MSDS for CytoFLEX Platform reagents used on the CytoFLEX Platform systems:

- On the Internet, go to [www.beckman.com](http://www.beckman.com):
  1. Select **Safety Data Sheets (SDS/MSDS)** from the Support menu.
  2. Follow the instructions on the screen.
  3. [Contact us](#) if you have difficulty locating the information.
- If you do not have Internet access, [contact us](#).

# Using the CytExpert Software

## Overview

---

The CytExpert software is a full-feature software package that controls the instrument operation, collection of experiment data, and analysis of the results. This chapter will explain the software functions and features.

This chapter contains information on:

- [Launching the Software](#)
- [Main Software Screen](#)
- [User Management](#)
- [Role Management](#)
- [Account Policies](#)
- [User Management Operation Log](#)
- [Graphic and Gating Styles](#)
- [Software Settings](#)

## Launching the Software

---

Select the desktop shortcut  to launch the CytExpert software.

If there is no desktop shortcut, run the “CytExpert.exe” software directly from the software installation directory. The default installation path is C:/Program Files/CytExpert. Or, select

 > **All Programs** > **CytExpert**.

Refer to [CHAPTER 4, Logging into the Software](#), for detailed instructions on opening the software and confirming the connection status.

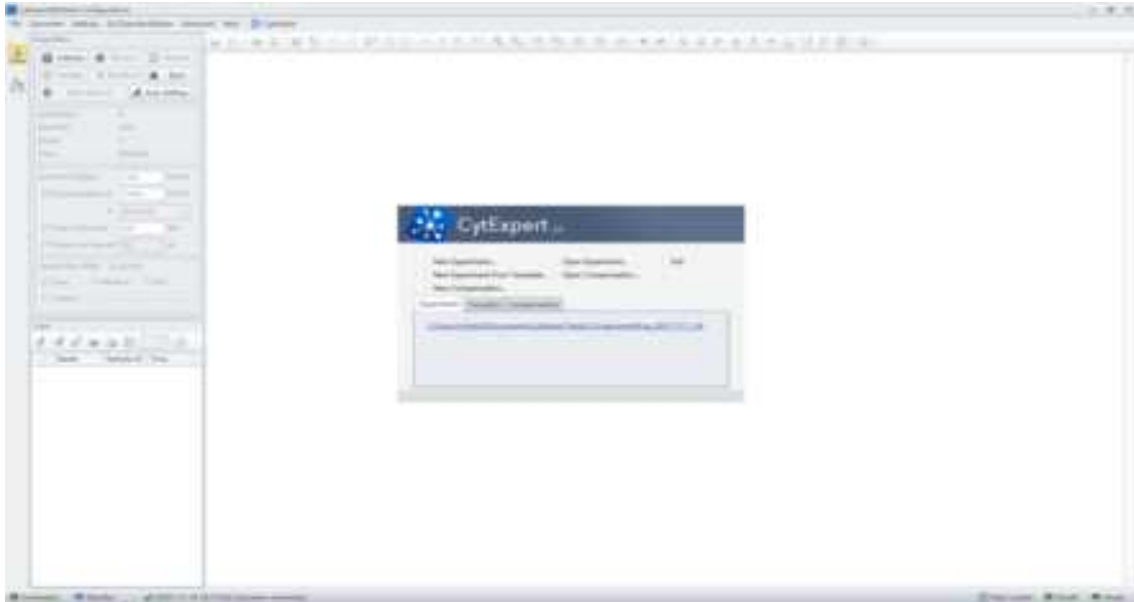
## Main Software Screen

---

Hover your cursor over any button to display a text pop-up of the button’s function.

## Start Page

The start page automatically opens after the software has been launched.




The following operations can be selected from the start page:

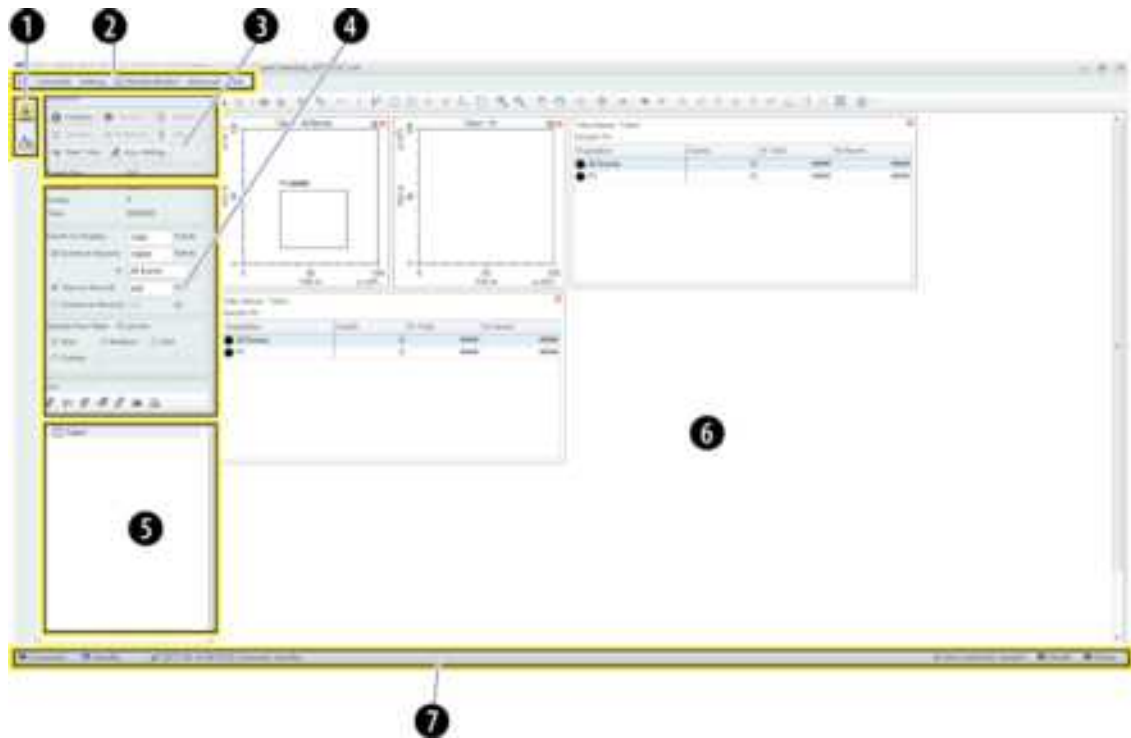


- **New Experiment.** For creating a new experiment. The process creates a file with the .xit extension and a folder with the same file name where the raw data (.fcs files) are kept.
- **New Experiment from Template.** For creating an experiment using a template saved from a previously saved experiment.
- **New Compensation.** For creating a new compensation experiment.
- **Open Experiment.** For opening a previously created experiment.
- **Open Compensation.** For opening a previously created compensation experiment.
- **Exit.** For exiting CytExpert.

The Experiment, Template, and Compensation tabs below give you the option of opening one of the 10 most recently opened experiments.

## Acquisition Screen

Selecting **New Experiment**, **New Experiment from Template**, or **Open Experiment** automatically opens the Acquisition screen. The Acquisition screen can be accessed by selecting  on the left side of the page.



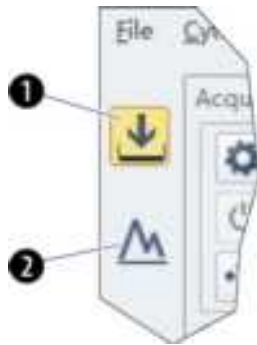
1. **Navigation.** Gives the option of accessing the Acquisition screen or Analysis screen.
2. **Menu.** Allows you to configure settings for sample acquisition, instrument operation, and software options.
3. **Instrument operation controls.** Controls sample loading/unloading and data acquisition and recording.
4. **Collection.** Establishes control over data recording options, displays the acquisition status, and controls the sample flow rate.
5. **Test tubes.** Allows you to configure and duplicate sample tubes, set display attributes, manage experimental data and compensation.

**NOTE** The Tube section of the screen can be expanded or retracted by dragging the top border of the Tube section of the screen. Expanding this section covers other elements of the screen, including: Events to Display, Events/Sec, and the Acquisition buttons.

6. **Plot area.** Includes plot and gating controls, as well as an area for creating plots and generating graphs.
7. **Status bar.** Displays instrument connection status and system information.

## Acquisition Screen Navigation

The Acquisition screens have two navigation icons, one for the Acquisition screen and the other for the Analysis screen.



1. **Acquisition screen icon.** Accesses the Acquisition screen.
2. **Analysis screen icon.** Accesses the Analysis screen.

## Collection

Standby state



Initialized state



1. **Acquisition control.** Controls sample loading/unloading and data acquisition and recording.
2. **Acquisition status.** Displays such information as the acquisition rate (Events/Sec), event count, duration, and abort (%).
3. **Acquisition conditions.** Sets the necessary conditions for recording data.
4. **Sample flow rate.** Sets the acquisition rate for data collection.

**NOTE** High acquisition rate may increase the abort rate and measurement CVs.

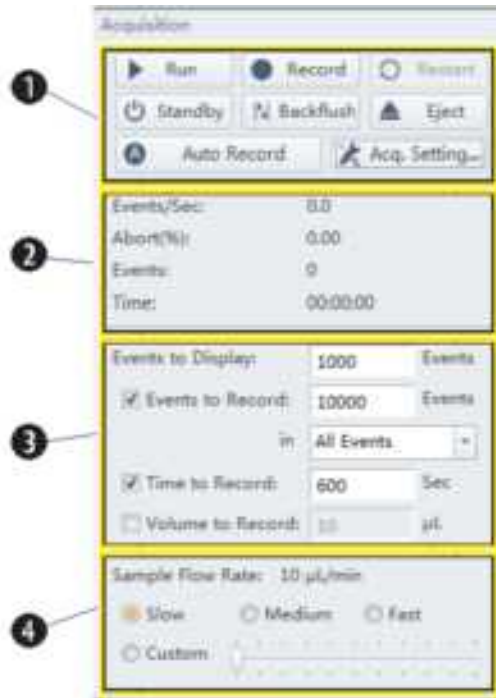
**Custom:** The flow rate can be adjusted in 1 µL increments.

## Collection [With Plate Loader]

Standby state



Initialized state

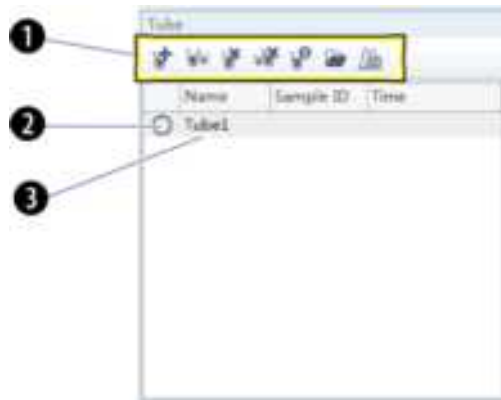


1. **Acquisition control.** Controls sample loading/unloading and data acquisition and recording.
2. **Acquisition status.** Displays such information as the acquisition rate (Events/Sec), event count, duration, and abort (%).
3. **Acquisition conditions.** Sets the necessary conditions for recording data.
4. **Sample flow rate.** Sets the acquisition rate for data collection.

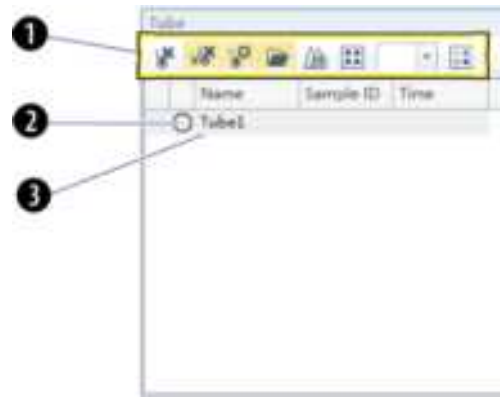
**NOTE** High acquisition rate may increase the abort rate and measurement CVs.

## Test Tubes

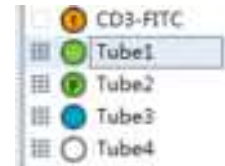
### Manual/Semi-Automatic Sample Injection Mode



### Plate Loader Sample Injection Mode




### Test Tube Status



- 1. Tube management controls.** Manages sample tubes. Used to add, copy, or delete attributes, open the tube property, and open the compensation matrix.
- 2. Test tube status indication.** Displays a colored symbol in front of each tube indicating the status of the tube processing.

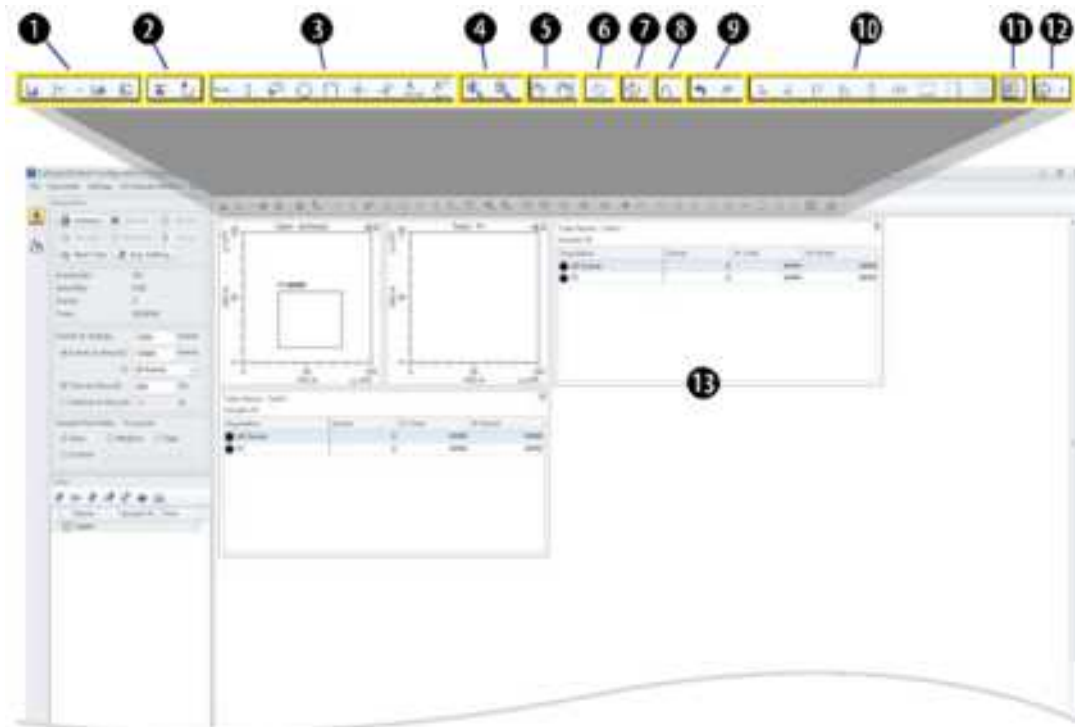
- indicates that the tube data was not collected.
- indicates that the tube data was acquired by selecting **Run** but can be overwritten.
- indicates that the tube data was saved by selecting **Record** or **Auto Record** and that this data cannot be overwritten.
- indicates imported FCS data.

**NOTE**  to the left of the test tube status indication symbol indicates that the sample has been compensated.

- indicates the data file is missing or there is an error in the data file.
- 3. Test tube list.** Displays the sample tubes used in the experiment. Right-click a tube in the list to perform additional operations.

**NOTE** In the Plate Loader Sample Injection mode the well number displays at the end of the tube name.

## Plot Area



1. **Plot controls.** For creating single or multiple plots, such as dot plots, histograms, density plots, pseudo color plots, and contour plots.
2. **Statistics and hierarchy controls.** For creating statistical and hierarchical charts.
3. **Graphical gating controls.** For creating graphical gates.
4. **Zoom controls.** For zooming in and out within a plot.
5. **Pan axis display controls.** For scaling axis ranges in the plots.
6. **Gain adjustment control.** For increasing and lowering gain adjustments on the plots.  
**NOTE** The gain adjustment control only works when a sample is running.
7. **Adjust compensation control.** For adjusting compensation of either of the parameters on a 2D histogram.
8. **Threshold control.** For setting the minimum particle size limit, scatter value, or fluorescence intensity that acquisition will allow.
9. **Undo and redo controls.** For undoing or redoing an action in the drawing area.
10. **Display controls.** For controlling how plots and tables are aligned and arranged.
11. **Rearrange.** For restoring the plots to the default positions.
12. **Printing controls.** For printing and previewing the plot area.
13. **Plot area.** For creating plots and displaying statistics and hierarchy tables.

## Status Bar



1. **Communication connection status.** Displays whether the Cytometer and the Workstation are connected.
2. **Instrument status information.** Displays the status of the Cytometer.
3. **Laser status.** Displays the status of each laser.

**NOTE** The laser status only displays when a required laser is disabled.

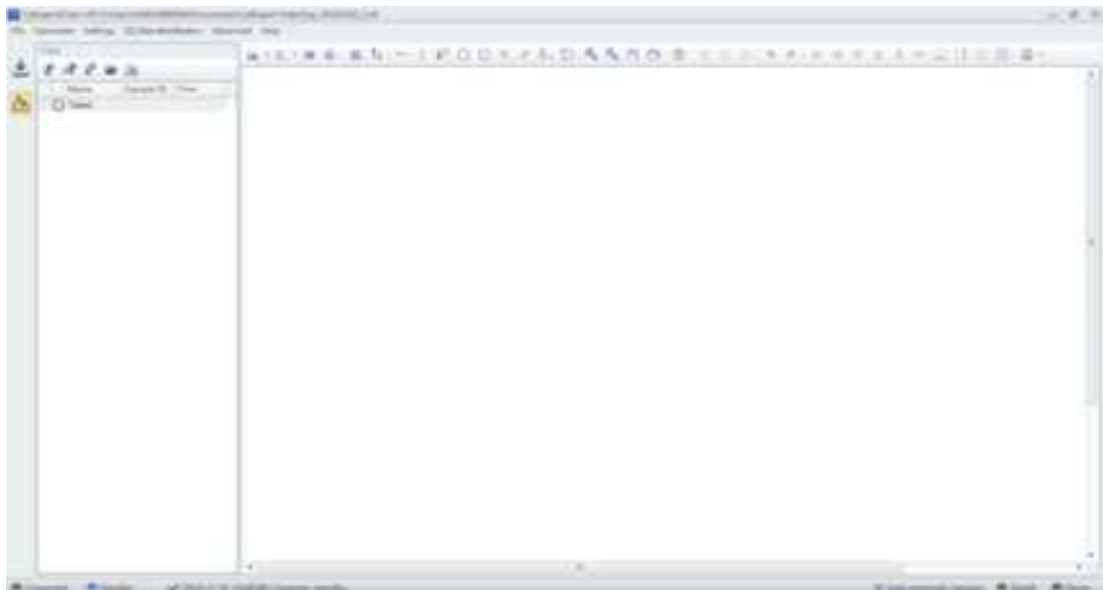
4. **Sampler status.** Displays the sample injection mode state. There are two sample injection modes: Semi-automatic sample injection mode and manual sample injection mode.

**NOTE** CytoFLEX Cytometers equipped with a plate loader have three sample injection modes: Semi-automatic sample injection mode, manual sample injection mode, and plate loader sample injection mode.

5. **Fluid status information.** Displays the liquid level of the Fluid Containers/Cubitainers.

## Analysis Screen

The Analysis screen is similar to the Acquisition screen, without the acquisition control modules.



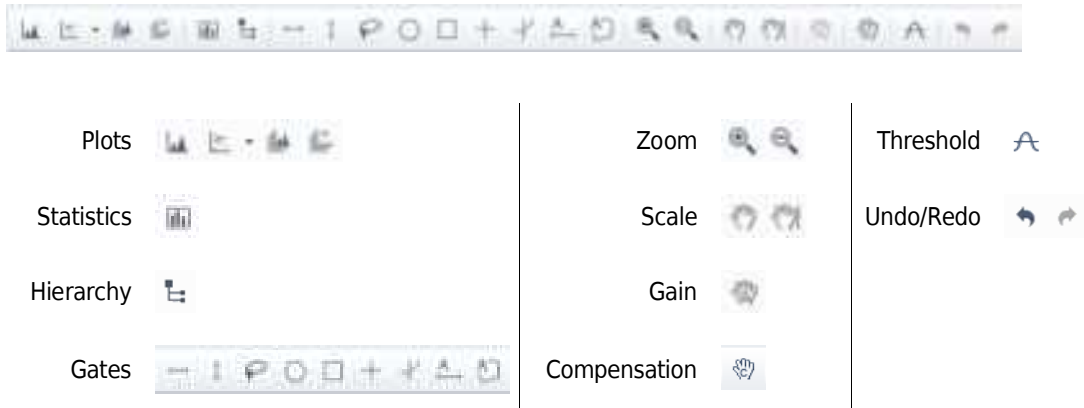
The Tube management module cannot add new sample tubes. Return to the Acquisition screen to add new sample tubes.

**Tube Management**



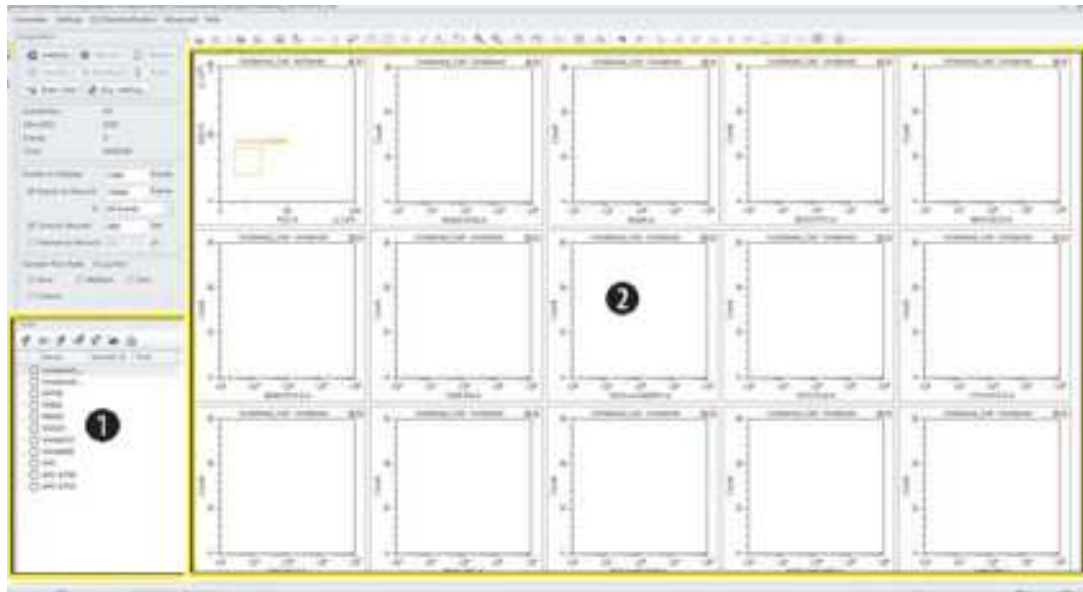
Drawing controls (see [Figure 2.1](#)) include the multi-data histograms and graphical display data controls.

**Figure 2.1** Drawing Controls Toolbar (Top of Screen)



## Compensation Experiment Screen

The Compensation Experiment screen appears when you open or create a new compensation experiment.



1. **Tube management.** Displays sample tubes required for the compensation experiment.
2. **Plot area.** Displays compensation plots and gating.

The Tube management section of the screen can import saved data (.fcs) files for computational purposes.

### Compensation Controls

The control area includes the compensation controls, coordinate pan axis display controls, gain adjustment controls, and the undo and redo controls. The compensation controls give you the option of calculating the compensation value, displaying the compensation matrix, or changing the compensation parameters.



Compensation Calculation



Single Side Pan



Compensation Matrix



Adjust Gain



Compensation Setup



Undo/Redo



Add/Delete Negative Gate



Alignment



Zoom



Print



Pan



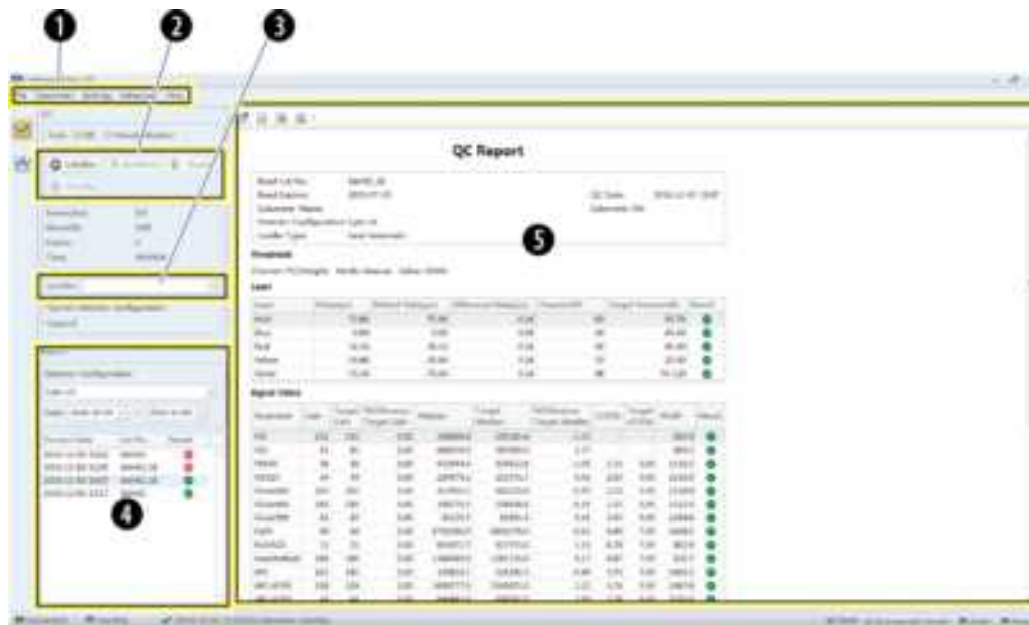
## QC Experiment Screen

The Quality Control (QC) Experiment screen appears when you access a QC experiment.

## QC Report Screen

Before starting the QC routine, a Settings screen appears.

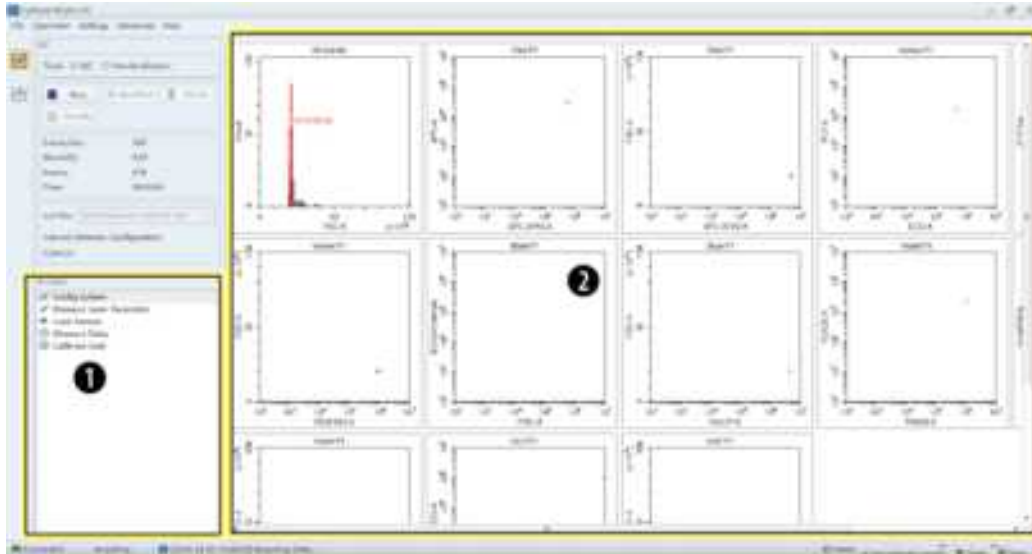
Figure 2.2 QC Report Screen



1. **Menu.** Allows you to configure settings related to QC experiments.
2. **Acquisition control.** Controls sample loading/unloading and data recording.
3. **Lot selection.** Allows you to select the lot number of the QC reagent.
4. **QC results list area.** Displays the time and results of completed QC runs.
5. **QC reports area.** Displays detailed reports for the selected QC experiment.

## QC Experiment Screen

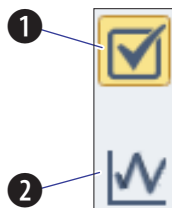
When acquiring QC samples, the software opens the QC screen.



1. **QC experiment progress indicator.** Displays the QC stage.
2. **Plot area.** Displays the QC plots.

## QC Screen Navigation

The Analysis screens have two navigation icons, one for the QC screen and the other for the Levey-Jennings (LJ) charts. Refer to [CHAPTER 5, Creating Levey-Jennings Charts](#).



1. **QC screen icon.** Accesses the QC screen.
2. **LJ screen icon.** Accesses the Levey-Jennings (LJ) screen.

## Software Menu

**IMPORTANT** All menu items apply to the CytExpert Default software option unless otherwise specified.

The CytExpert software contains the following selectable menu items:

**Figure 2.3** Software Menu Tree\*

File	Cytometer	Settings	QC/Standardization	Advanced	Account††	Log††	Signature†††	Backup/Restore††	Help
New Experiment	Acq Setting	Set Channel	Start	Order Setting	User Manager††	Experiment	Sign†††	Backup††	View Help File
New Experiment			QC/Standardization			Operation Log†††			
Print Template	Detector Configuration	Set Label		Label Setting	Role Manager††	System	Recover†††	Restore††	About
New Compensation		Set Customized Parameter		Alarm/Warning	Account Purview††	Operation Log†††	Signature		
Open Experiment	Reset††	Set Assession Per User†††		Event Risk Setting	Change Password†††	Operation Log†††	Signature	Log Channel††	
Open Compensation		Automation Period Options††††		Plate Type Library†			Signature		
Save	Monitor	Compensation Matrix					Signature		
Save As	Print	Compensation Library					Signature		
Save As Template	Print Clear	Event Display Setting					Signature		
Import FCS File	Call to Set Sample Flow Rate	Language Setting					Signature		
Export FCS File	System Status Program	Set Experiment Directory†††					Signature		
Recent	Daily Clean	Options	Experiment†††				Signature		
Recent Template	Single Injection	Alarm	Task				Signature		
Recent Compensation	Blank	Auto Automatic	Print				Signature		
Open Experiment	Blank	Plate Loader†††	State				Signature		
Experiment Explorer††††	Sanctory Reset		Page Setup				Signature		
Exit	Turn On†††		Plate Loader				Signature		
	Turn Off†††						Signature		
	Acq Setting Caching						Signature		
	Cytometer Configuration						Signature		
	Customer Information						Signature		

\* The menu options for **File**, **Cytometer**, **Settings**, and **QC/Standardization** change when you select Start QC/Standardization. Refer to [Figure 2.4](#).

† **Boost** is only active in the Manual Sample Injection mode.

‡ **Plate Type Library** is only an option if the Plate Loader module is installed and the Plate Loader Sample Injection mode is selected.

\*\* **Plate Loader** is only an option if the Plate Loader module is installed.

†† These options are only available if the CytExpert User Management or CytExpert Electronic Record Management software option is installed.

‡‡ **Experiment** is only an option if either the CytExpert Default or the CytExpert User Management software option is installed.

\*\*\* These options are only available if the CytExpert Electronic Record Management software option is installed.

††† These options are only available on the CytoFLEX LX flow cytometer.


The  icon is hyper linked to the Cytobank spotlight page where you can login to the Cytobank Premium server, request a 30-day free trial and access additional information. The Cytobank platform allows you to analyze, manage, and securely share flow cytometry data. FCS files can be uploaded to the platform with the related attachments such as PDF files.

Figure 2.4 QC Software Menu Tree

File	Cytometer	Settings	Advanced	Account††	Log‡	Signature**	Backup/Restore‡‡	Help
New Experiment	Detector Configuration	Retention Period Options**	Delay Setting	User Manager‡‡	Experiment Operation Log**	Sign***	Backup‡‡	View Help File
New Experiment From Template	Backflush	QC/Standardization Setting	Lower Setting	Role Manager‡‡	System Operation Log**	Report***	Restore‡‡	About
New Compensation	Print*	Target Library	Maintenance	Account Policies‡‡	User Management Operation Log‡‡	Signature Records***	Log Cleanup‡‡	
Open Experiment	Initialize	Standardization Target Library	Event Rate Setting	Change Password‡‡		Signature Settings***		
Open Compensation	Standby	Set Experiment Directory**	Plate Type Library†					
Reset	Prime	Language Setting						
Reset Template	Deep Clean		Experiment††					
Reset Compensation	Calibrate Sample Flow Rate		Type					
Close	System Startup							
QC/Standardization Experiment	Program	Options						
Explorer**	Daily Clean							
Exit	Sample Injection Mode							
	Manual Semi Automatic Plate Loader							
	Sampler Reset							
	Turn On***							
	Turn Off***							
	Acq. Setting Catalog							
	Cytometer Configuration							
	Cytometer Information							

\* **Boost** is only active in the Manual Sample Injection mode.

† **Plate Type Library** is only an option if the Plate Loader module is installed and the Plate Loader Sample Injection mode is selected.

‡ **Plate Loader** is only an option if the Plate Loader module is installed.

\*\* These options are only available if the CytExpert Electronic Record Management software option is installed.

†† **Experiment** is only an option if either the CytExpert Default or the CytExpert User Management software option is installed.

‡‡ These options are only available if either the CytExpert User Management or the CytExpert Electronic Record Management software option is installed.

\*\*\* These options are only available on the CytoFLEX LX flow cytometer.

## Acquisition and Analysis Screen Menu

### CytExpert Default Software Option

File Cytometer Settings QC/Standardization Advanced Help

### CytExpert User Management Software Option

File Cytometer Settings QC/Standardization Advanced Account Log Backup/Restore Help

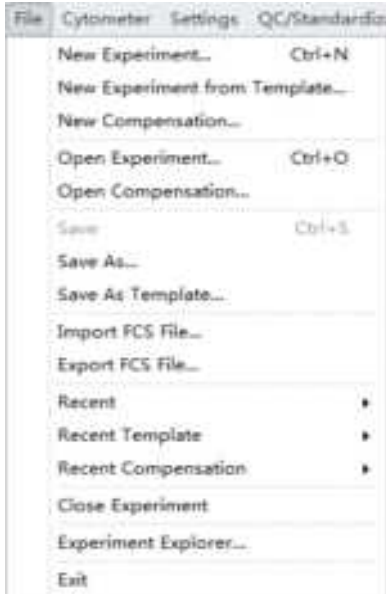
### CytExpert Electronic Record Management Software Option

File Cytometer Settings QC/Standardization Advanced Account Log Signature Backup/Restore Help

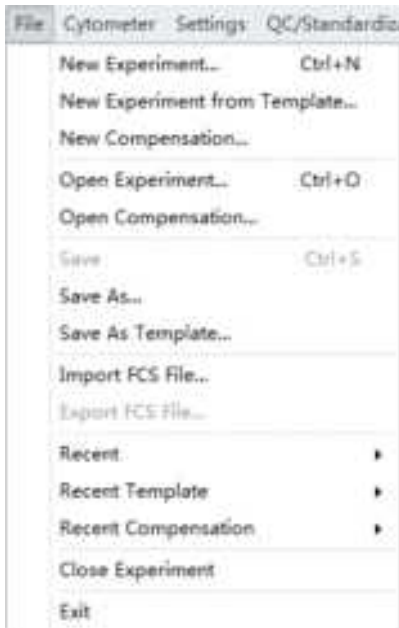
## File Menu

For creating new experiments, opening existing experiments, saving new experiments and data, and importing/exporting FCS data files.

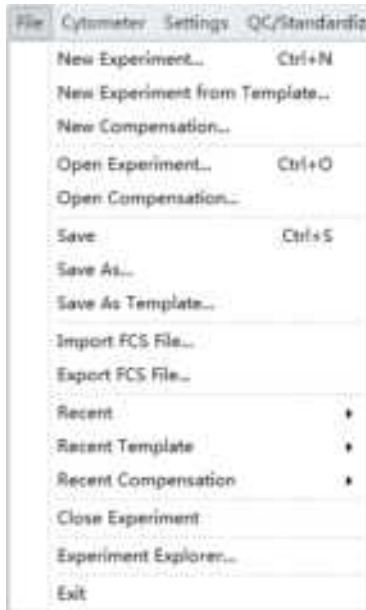
### CytExpert Default Software Option



### CytExpert User Management Software Option



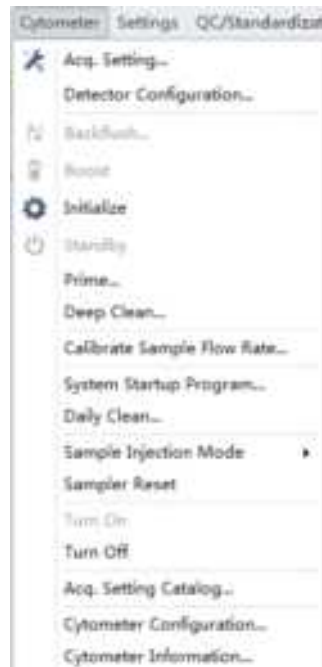
**CytExpert Electronic Record Management Software Option**



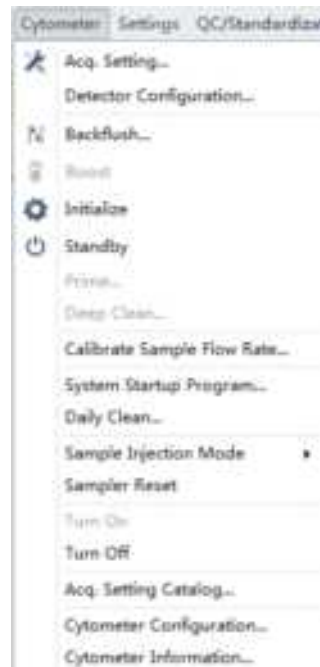
**Cytometer Menu**

For configuring Cytometer settings and controlling Cytometer functions. Depending on the Cytometer state, certain functions may not be available.

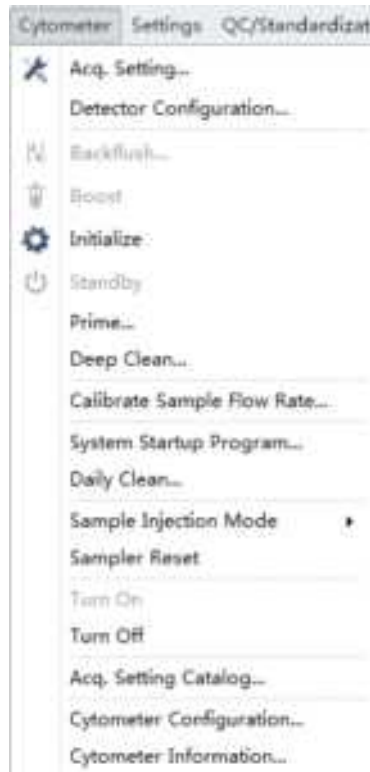
**CytExpert Default Software Option - Standby state**



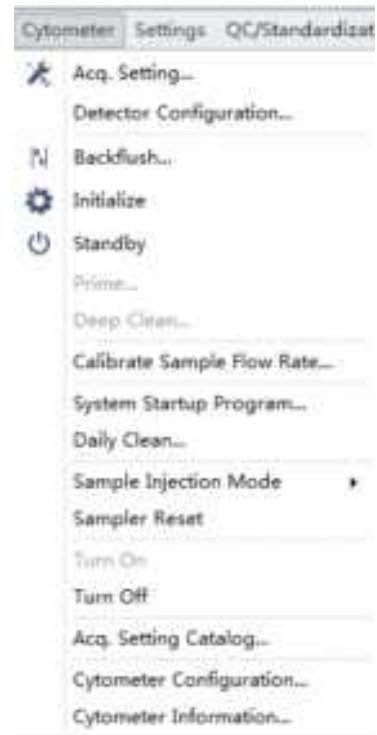
**CytExpert Default Software Option - Initialized state**



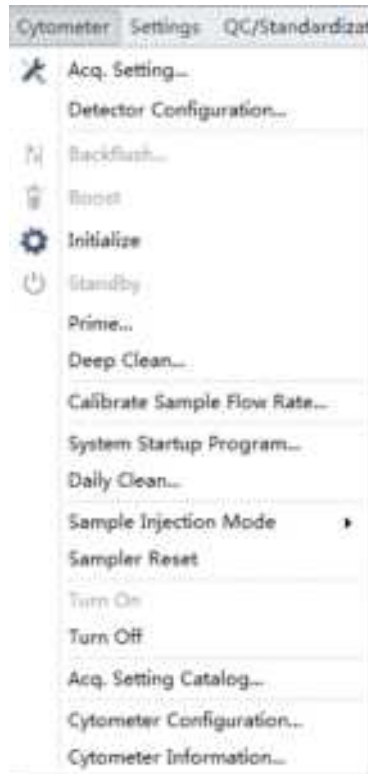
CytExpert User Management Software Option -  
Standby state



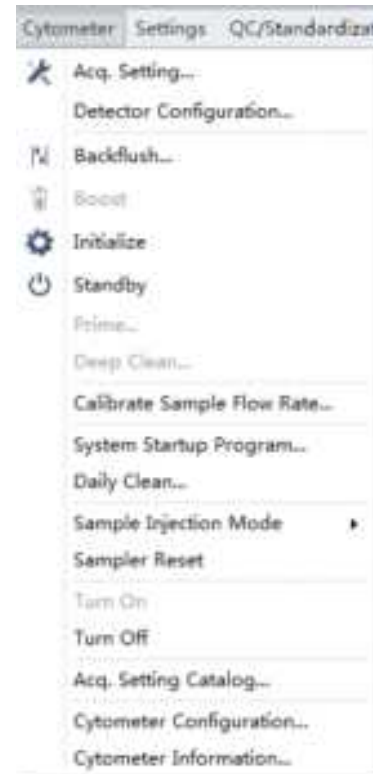
CytExpert User Management Software Option -  
Initialized state



CytExpert Electronic Record Management  
Software Option - Standby state



CytExpert Electronic Record Management  
Software Option - Initialized state

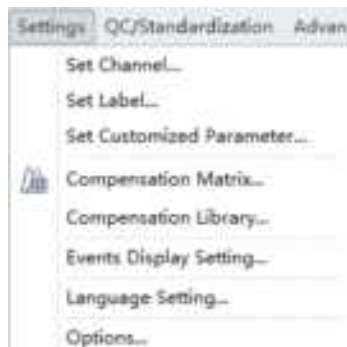


**NOTE** The **Turn On** and **Turn Off** selections are only available on the CytoFLEX LX.

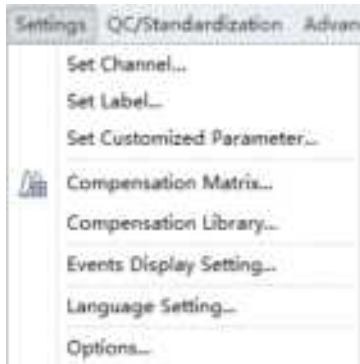
### Settings Menu

Used to select and/or change software options and settings.

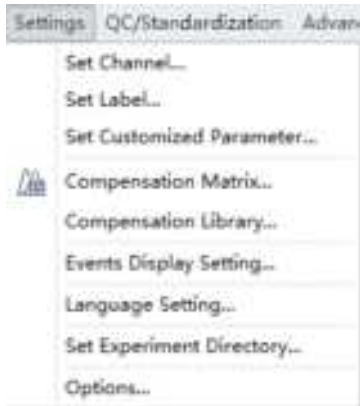
### CytExpert Default Software Option



### CytExpert User Management Software Option



### CytExpert Electronic Record Management Software Option



### QC/Standardization Menu

Select **Start QC/Standardization** from the QC/Standardization menu to start the QC routine.

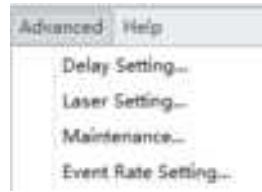


**NOTE** The QC/Standardization menu is the same for the CytExpert Default, CytExpert User Management, and the CytExpert Electronic Record Management software options.

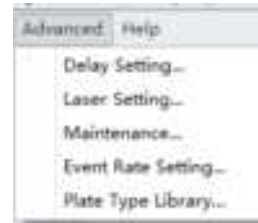
### Advanced Menu

Used to access advanced settings for experienced users. Includes laser time delay settings.

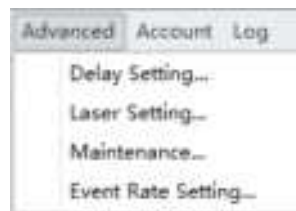
**CytExpert Default Software Option -  
Semi-Automatic/Manual Sample Injection Mode**



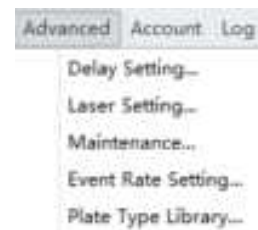
**CytExpert Default Software Option - Plate Loader  
Sample Injection Mode**



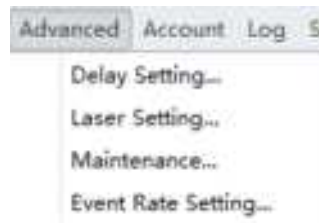
**CytExpert User Management Option -  
Semi-Automatic/Manual Sample Injection Mode**



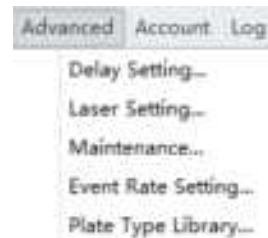
**CytExpert User Management Software Option -  
Plate Loader Sample Injection Mode**



**CytExpert Electronic Record Management  
Software Option - Semi-Automatic/Manual  
Sample Injection Mode**



**CytExpert Electronic Record Management  
Software Option - Plate Loader Sample Injection  
Mode**



**Account Menu**

Used to for user account management settings.

**CytExpert User Management Software Option**



**CytExpert Electronic Record Management Software Option**



**NOTE** The Account menu is not available in the CytExpert Default software option.

### Log Menu

Used to access logs including the Experiment Operation Log, the System Operation Log, and the User Management Operation Log.

#### CytExpert User Management Software Option



#### CytExpert Electronic Record Management Software Option



**NOTE** The Log menu is not available in the CytExpert Default software option.

### Signature Menu

Used to sign experiment and view signature details.

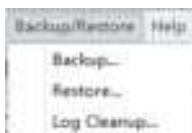
#### CytExpert Electronic Record Management Software Option



**NOTE** The Signature menu is only available in the CytExpert Electronic Record Management software option.

### Backup/Restore Menu

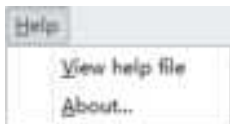
Used to backup/restore databases. Refer to [CHAPTER 10, Backup and Restore](#).



**NOTE** The Backup/Restore menu is not available in the CytExpert Default software option.

### Help Menu

For displaying software version information and system Instructions for Use.



**NOTE** The Help menu is the same for the CytExpert Default, CytExpert User Management, and CytExpert Electronic Record Management software options.

## User Management

**IMPORTANT** Only an Administrator can manage users. You must have either the CytExpert User Management or CytExpert Electronic Record Management software option installed to use this feature. Refer to [APPENDIX A, CytExpert Software Installation Options](#).

User Management is used to create and manage user accounts.

Select **Account > User Manager**. The User Manager window appears.

**Figure 2.5** User Manager (Card View)

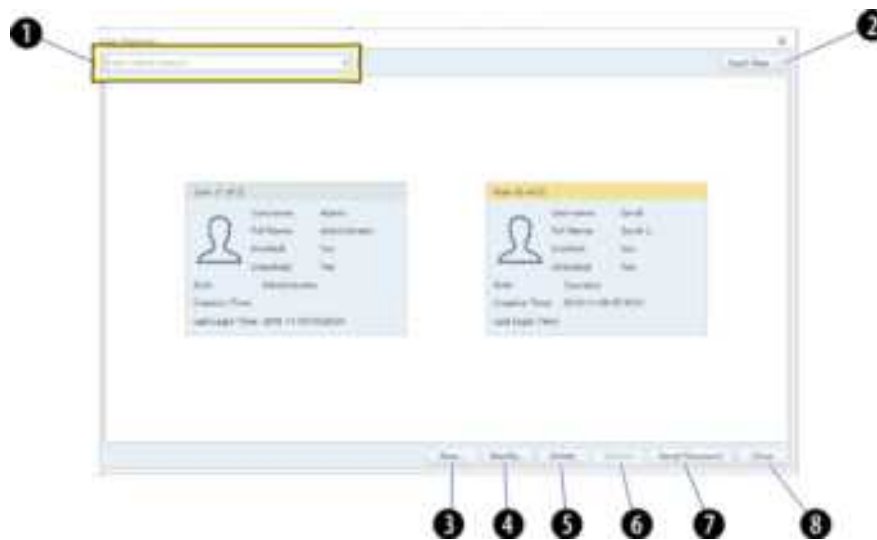


Figure 2.6 User Manager (Grid View)




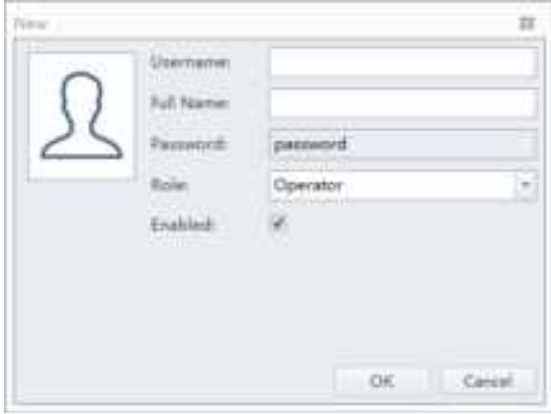
1. **Search text box:** Filters users by username and display name.
2. **View drop-down:** Toggles between Card View (see [Figure 2.5](#)) and Grid View (see [Figure 2.6](#)).
3. **New:** Used to create a new user profile.
4. **Modify:** Used to modify an existing user profile.
5. **Delete:** Used to delete an existing user profile.
6. **Unlock:** Used to unlock an existing account that has been locked.  
**NOTE** An account locks after 3 failed password attempts. The number of attempts can be changed by the administrator. Refer to [Account Policies](#).  
**NOTE** An account automatically unlocks after 30 minutes. The duration can be changed by the administrator. Refer to [Account Policies](#).
7. **Reset password:** Used to reset an existing user password to the default password: *password*.
8. **Close:** Closes the User Manager window.

## Creating, Deleting, and Modifying Users in User Manager

### Creating a New User in User Manager

---


- 1 Select  in the User Manager window. The New window appears.



- 2 Fill in the new user information.
  - a. Enter the Username.
  - b. Enter the Full Name.
  - c. Select the user Role.
  - d. Select the Enabled checkbox to enable the user.

**NOTE** The Enabled checkbox can only be changed by an administrator.

---


- 3 Select . The new user displays in User Manager.
- 

- 4 Select .
-

## Deleting Users in User Manager

---

**IMPORTANT** If an account has been used and log information has been generated related to it, the account cannot be deleted, but it can be disabled.

- 1 Select the user to be deleted in the User Manager window then select  .

**NOTE** The user 'Admin' is a system default user and cannot be deleted.


---

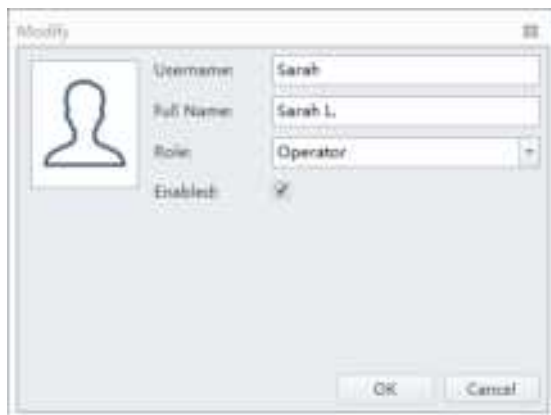
- 2 Select  .
- 

## Modifying Users in User Manager

---

**IMPORTANT** If an account has been used and log information has been generated related to it, the username cannot be modified.

- 1 Select  in the User Manager window. The Modify window appears.



**NOTE** The user 'Admin' is a system default user and cannot be modified.

---

- 2 Modify the user information as necessary.

**NOTE** Uncheck the enabled box to disable a user.

---

- 3 Select  .
- 


- 4 Select  .
-

## Unlocking a User Account

Select a *Locked* user in the User Manager window and select **Unlock**.

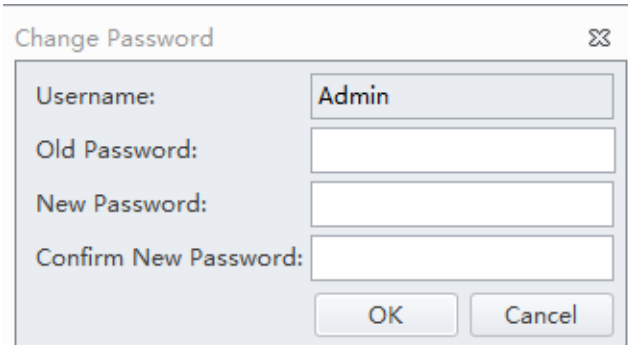
**NOTE** You cannot unlock an active user.

## Resetting a User Passwords

Select a user in the User Manager window then select . The user password is automatically reset as *password*.

## Changing a User Password

- 1 Select **Account > Change Password**. The Change Password window appears.



The image shows a 'Change Password' dialog box with a close button (X) in the top right corner. It contains four text input fields: 'Username:' with the value 'Admin', 'Old Password:', 'New Password:', and 'Confirm New Password:'. At the bottom, there are two buttons: 'OK' and 'Cancel'.

- 2 Enter the current password, the new password, and confirm the new password.

- 3 Select .

## Role Management

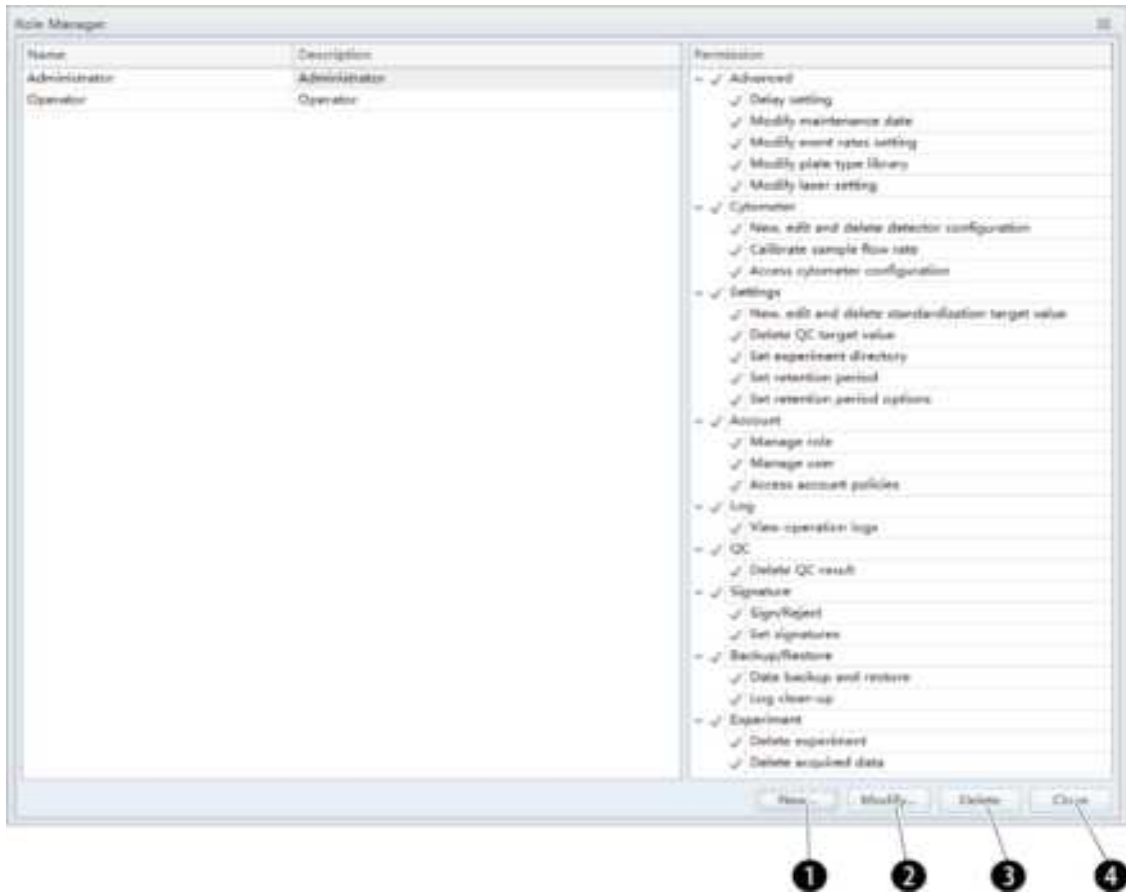
**IMPORTANT** Only an Administrator can manage users. You must have either the CytExpert User Management or CytExpert Electronic Record Management software option installed to use this feature. Refer to [APPENDIX A, CytExpert Software Installation Options](#).

Role Management is used to manage user account permissions.

**NOTE** Multiple users can be applied to the same role.

Select **Account > Role Manager**. The Role Manager window appears. Refer to [Figure 2.7](#).

**Figure 2.7** Role Manager

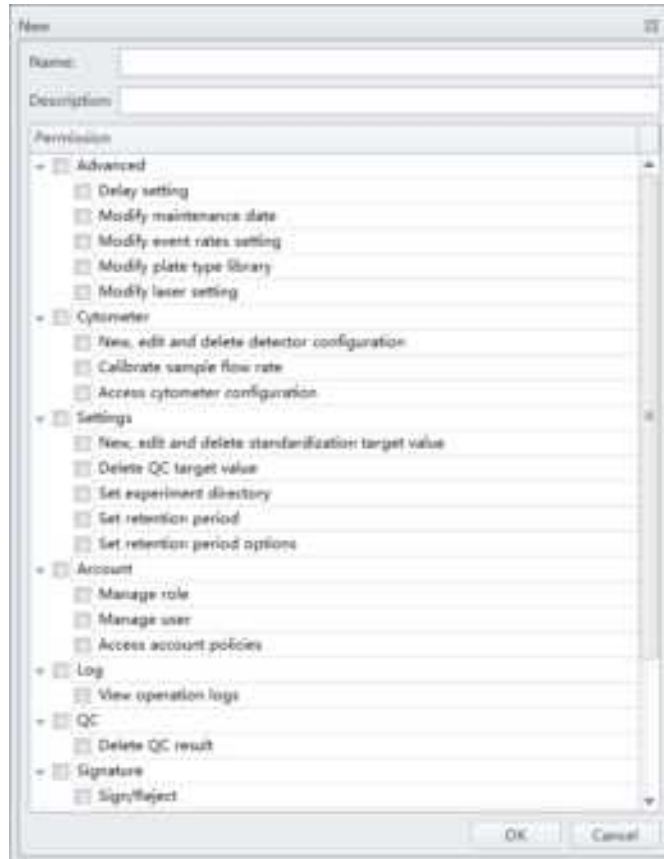


1. **New:** Used to create a new role profile.
2. **Modify:** Used to modify an existing role profile.
3. **Delete:** Used to delete an existing role profile.
4. **Close:** Closes the Role Manager window.

## Creating, Deleting, and Modifying User Roles in Role Manager

### Creating New User Roles in Role Manager

- 1 Select  . The New window appears.



- 2 Fill in the new role information.
  - a. Enter the role name.
  - b. Enter the role description.
  - c. Select the permissions applicable to the new role.
- 3 Select  . The new role displays in the role list.
- 4 Select  .

## Deleting User Roles in Role Manager

---

**IMPORTANT** If a role has already been assigned to a user, that role cannot be deleted.

**IMPORTANT** The Administrator and Operator Roles are system defaults and may not be deleted.

1 Select the Role to be deleted in Role Manager then select  .

---

2 Select  .

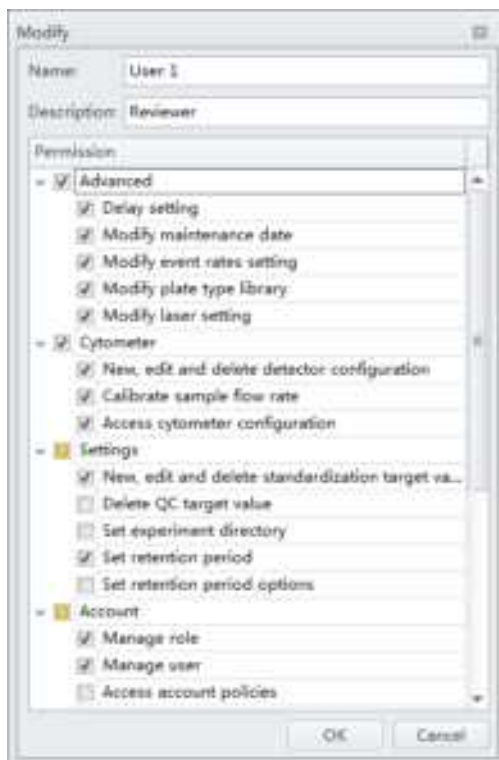
---

## Modifying User Roles in the Role Window

---

**IMPORTANT** The Administrator and Operator Roles are system defaults and may not be modified.

1 Select  . The Modify window appears.



2 Modify the role information as necessary.

---

3 Select  .

4 Select  .

## Account Policies

**IMPORTANT** Only an Administrator or an account has the Manage user permission can manage users. You must have either the CytExpert User Management or CytExpert Electronic Record Management software option installed to use this feature. Refer to [APPENDIX A, CytExpert Software Installation Options](#).

Account policies is used to define the default properties for the password policy, account lockout policy, and application inactivity policy.

Select **Account > Account Policies**. The Account Policies window appears.

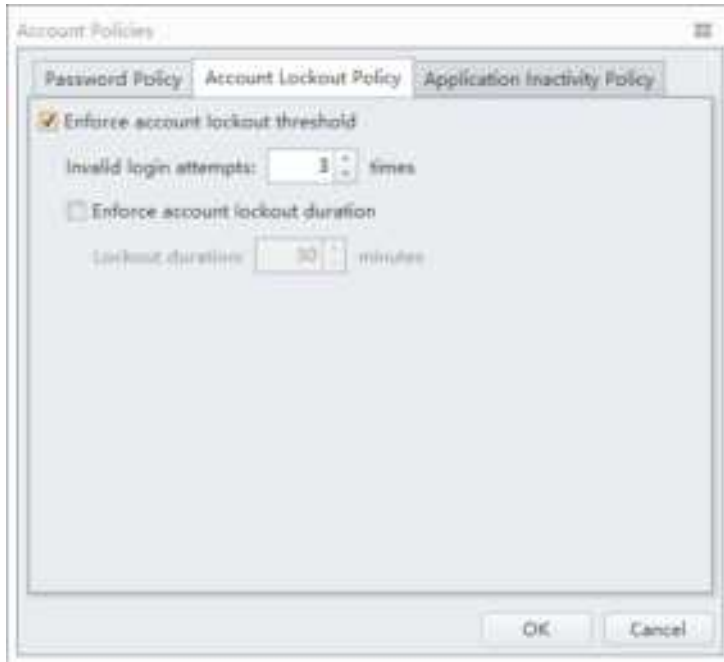
**Figure 2.8** Account Policies - Password Policy



**NOTE** The allowable range for each entry is as follows:

- Password History: 12-24 times
- Password Length: 8-14 characters
- Minimum Age for Password: 0-998 days
- Password Expiration: 1-999 days
- Reminder for Expiration: 1-90 days

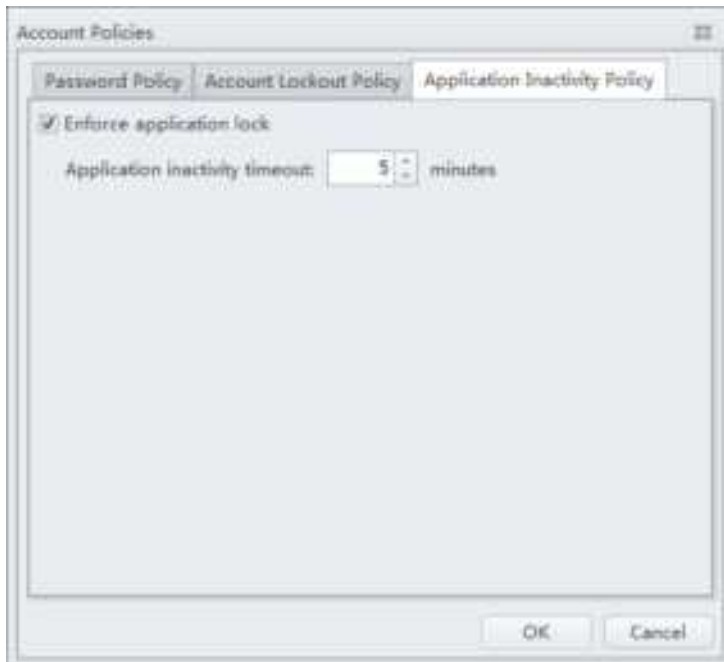
**Figure 2.9** Account Policies - Account Lockout Policy



**NOTE** The allowable range for each entry is as follows:

- Invalid Login Attempts: 3-10 times
- Lockout Duration: 15-1440 minutes

**Figure 2.10** Account Policies - Application Inactivity Policies



**NOTE** The allowable range for each entry is as follows:

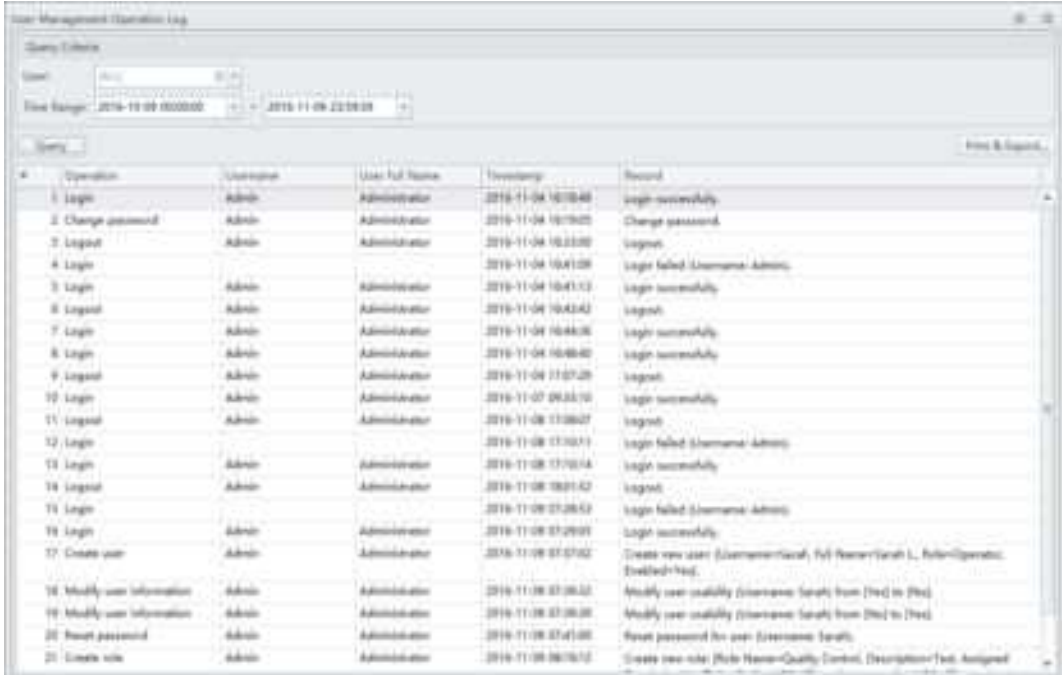
- Inactivity Duration: 1-60 minutes

## User Management Operation Log

**IMPORTANT** You must have either the CytExpert User Management or CytExpert Electronic Record Management software option installed to use this feature. Refer to [APPENDIX A, CytExpert Software Installation Options](#).

### Viewing and Exporting User Logs

- 1 Select **Log > User Management Operation Log**. The Logs window appears.



The screenshot shows the 'User Management Operation Log' window. At the top, there is a 'Query Criteria' section with a 'User' dropdown set to 'Admin' and a 'Time Range' from '2016-11-09 00:00:00' to '2016-11-09 23:59:59'. Below this is a 'Query' button and a 'Print & Export...' button. The main area is a table with the following columns: Operation, Username, User Full Name, Timestamp, and Record.

Operation	Username	User Full Name	Timestamp	Record
1 Login	Admin	Administrator	2016-11-09 10:00:00	Login successfully.
2 Change password	Admin	Administrator	2016-11-09 10:10:00	Change password.
3 Logout	Admin	Administrator	2016-11-09 10:20:00	Logout.
4 Login	Admin	Administrator	2016-11-09 10:41:00	Login failed (Username: Admin).
5 Login	Admin	Administrator	2016-11-09 10:41:10	Login successfully.
6 Logout	Admin	Administrator	2016-11-09 10:42:00	Logout.
7 Login	Admin	Administrator	2016-11-09 10:44:00	Login successfully.
8 Login	Admin	Administrator	2016-11-09 10:46:00	Login successfully.
9 Logout	Admin	Administrator	2016-11-09 11:07:00	Logout.
10 Login	Admin	Administrator	2016-11-07 09:33:10	Login successfully.
11 Logout	Admin	Administrator	2016-11-08 11:00:07	Logout.
12 Login	Admin	Administrator	2016-11-08 11:00:11	Login failed (Username: Admin).
13 Login	Admin	Administrator	2016-11-08 11:01:14	Login successfully.
14 Logout	Admin	Administrator	2016-11-08 16:01:42	Logout.
15 Login	Admin	Administrator	2016-11-08 17:05:52	Login failed (Username: Admin).
16 Login	Admin	Administrator	2016-11-08 17:09:01	Login successfully.
17 Create user	Admin	Administrator	2016-11-08 17:07:02	Create new user (Username: Sarah, Full Name: Sarah L. Rollins-Operator, Enabled: Yes).
18 Modify user information	Admin	Administrator	2016-11-08 17:08:22	Modify user usability (Username: Sarah from (Yes) to (No)).
19 Modify user information	Admin	Administrator	2016-11-08 17:08:30	Modify user usability (Username: Sarah from (No) to (Yes)).
20 Reset password	Admin	Administrator	2016-11-08 17:47:00	Reset password for user (Username: Sarah).
21 Create role	Admin	Administrator	2016-11-08 18:16:12	Create new role (Role Name: Quality Control, Description: Test, Assigned

- 2 Enter the filter conditions: User and Time Range.

- 3 To export the log, select **Print & Export...**.

**NOTE** User logs are exported as a .pdf or .csv file.

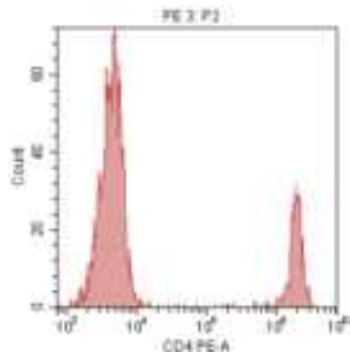
## Graphic and Gating Styles

### Plots

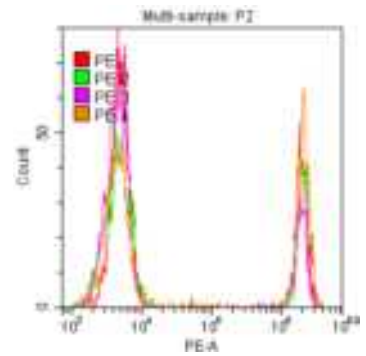
The CytExpert software offers a variety of plot formats including:

- Single-parameter plots and histogram overlays
- Dual-parameter plots: dot plots, density plots, pseudo color plots, contour plots, and dot plot overlays

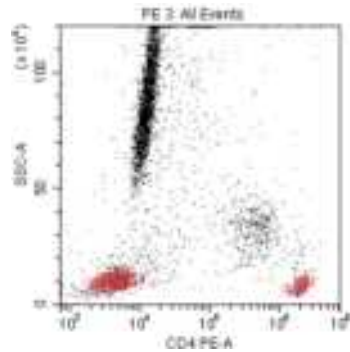
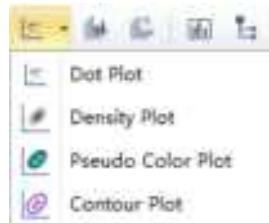
**NOTE** Histogram Overlays and Dot Plot Overlays can only be created from multiple samples in the Analysis screen. A maximum of 10 samples can be overlaid.



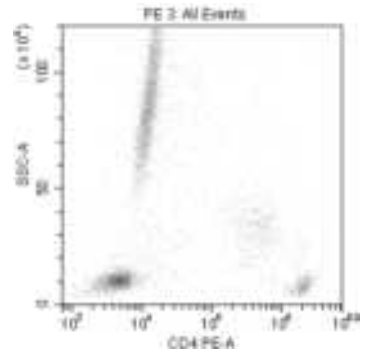
Histogram



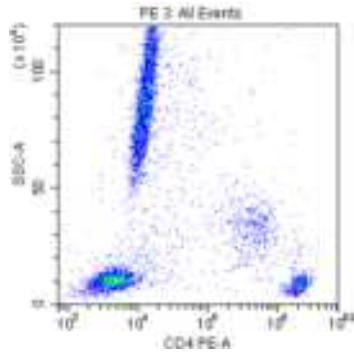
Multi-sample histogram overlays



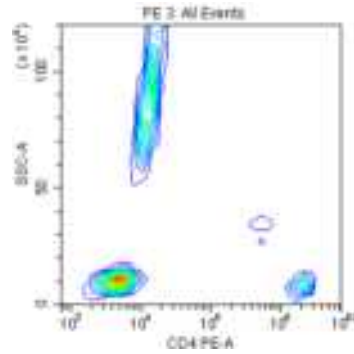
Dot plot



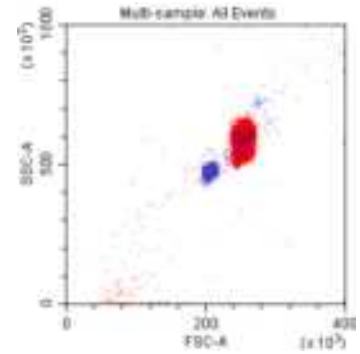
Density plot



Pseudo color plot



Contour plot



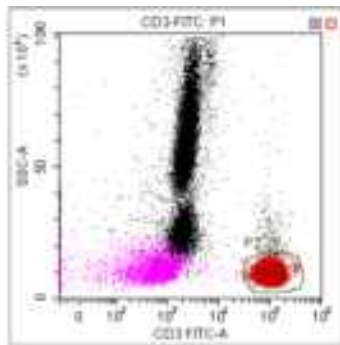
Dot plot overlay

## Gates

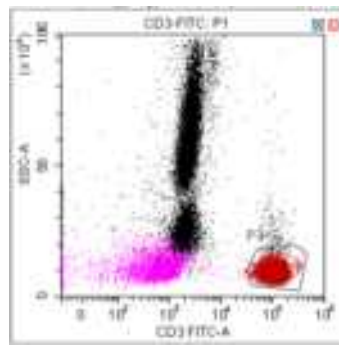
Various gating choices are available.

The software includes the following gate types:

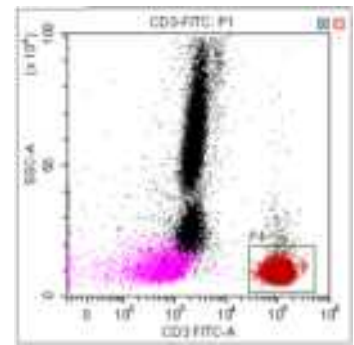
- For dual-parameter plots: lasso, polygon, rectangle, four-quadrant, hinged gates, and auto polygon
- For single-parameter plots: line-segment, vertical gates, and auto line segment



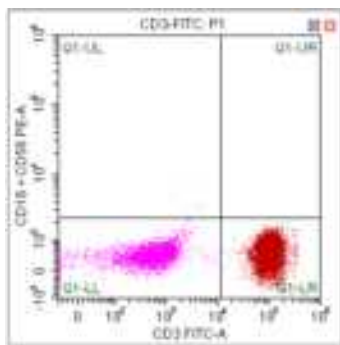
Lasso gate



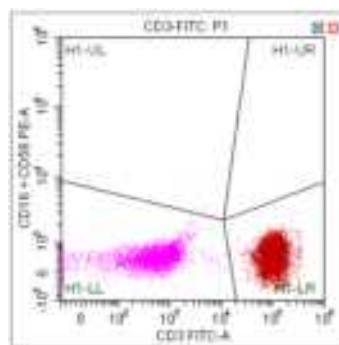
Polygon gate<sup>a</sup>



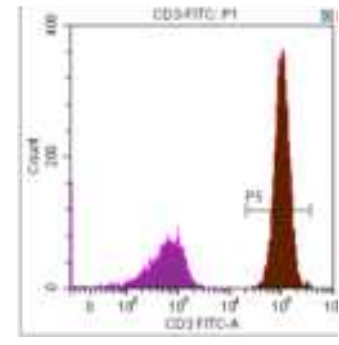
Rectangle gate



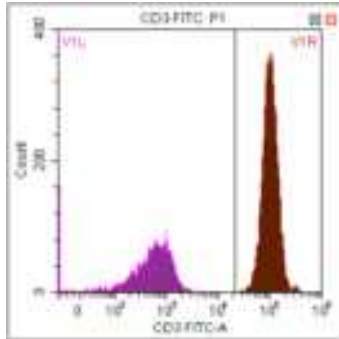
Four-Quadrant gate



Hinged gate



Line Segment gate<sup>a</sup>



Vertical gate

- a. This gate can be created using the autogate functionality. Refer to [CHAPTER 6, Creating and Adjusting Auto Gates](#).

## Plate Type Library

The Plate Type Library is used to manage and calibrate plates. Plates can be added, deleted, duplicated, and edited from the Plate Type Library. To calibrate a plate, refer to [CHAPTER 12, Calibrating the Plate Position \[With Plate Loader\]](#).


Select **Advanced > Plate Type Library** to access the Plate Type Library. Refer to [Figure 2.11](#).

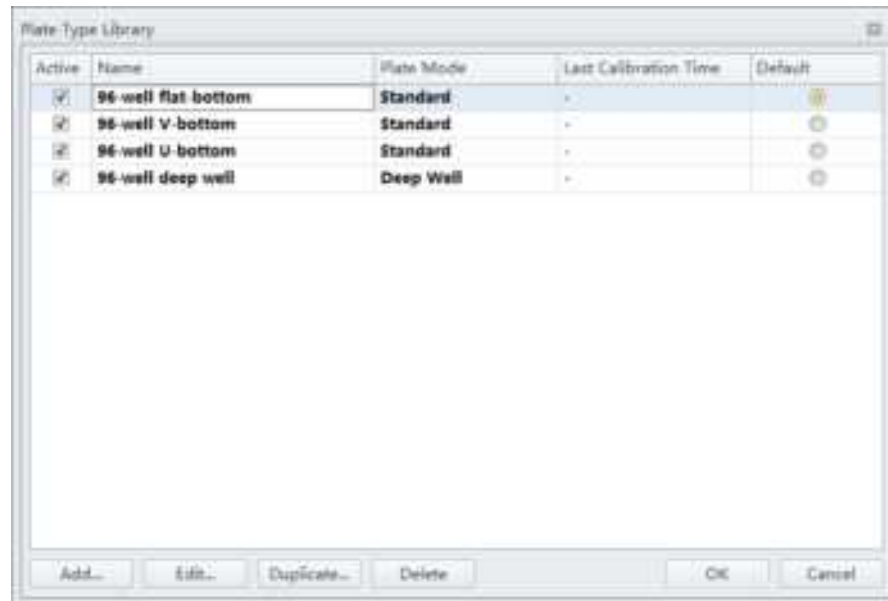
Figure 2.11 Plate Type Library



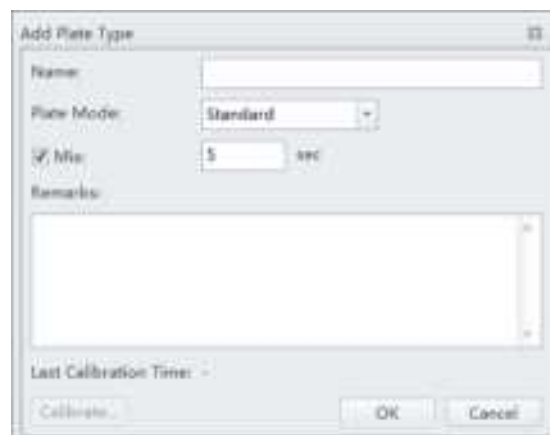
- 1. **Active.** Indicates that the plate type is available for use.
- 2. **Default.** Applies the default settings.
- 3. **Add.** Creates a new plate.
- 4. **Edit.** Edits a plate.
- 5. **Duplicate.** Duplicates a plate.
- 6. **Delete.** Deletes an existing plate.
- 7. **OK.** Saves the plate type.
- 8. **Cancel.** Cancels the settings.

## Adding a Plate Type

- 1 Select .
- 2 Select **Advanced > Plate Type Library**. The Plate Type Library window appears.



- 3 Select **Add**. The Add Plate Type window appears.



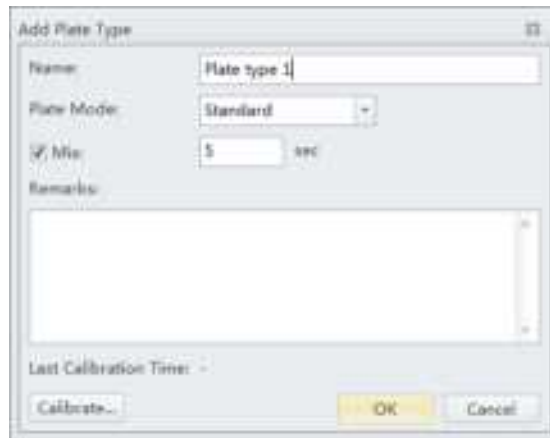
- 4 Enter the plate name in the Name section of the screen.

The screenshot shows the 'Add Plate Type' dialog box. The 'Name' field is filled with 'Plate type 1'. The 'Plate Mode' dropdown menu is set to 'Standard'. The 'W. No.' field is filled with '5' and 'sec' is next to it. The 'Remarks' field is empty. The 'Last Calibration Time' is '-'. At the bottom, there are three buttons: 'Calibrate', 'OK', and 'Cancel'.

- 5 Select the Plate Mode.

The screenshot shows the 'Add Plate Type' dialog box with the 'Plate Mode' dropdown menu open. The menu shows 'Standard' and 'Deep Well' options. The 'Name' field is filled with 'Plate type 1'. The 'W. No.' field is filled with '5' and 'sec' is next to it. The 'Remarks' field is empty. The 'Last Calibration Time' is '-'. At the bottom, there are three buttons: 'Calibrate', 'OK', and 'Cancel'.

- 
- 6 Enter the Mix time.



The screenshot shows a dialog box titled "Add Plate Type". It contains the following fields and controls:

- Name:** A text input field containing "Plate type 1".
- Plate Mode:** A dropdown menu currently set to "Standard".
- Mix:** A checked checkbox next to a text input field containing "5" and the unit "sec".
- Remarks:** A large empty text area.
- Last Calibration Time:** A text input field that is currently empty.
- Buttons:** "Calibrate..." (highlighted in yellow), "OK", and "Cancel".

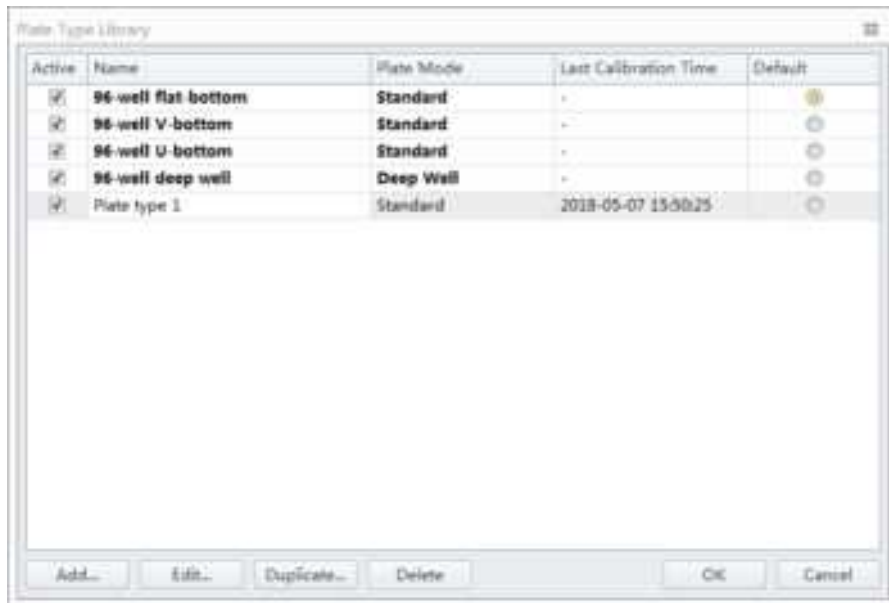
**NOTE** The default setting is 5 seconds in Standard Mixing Mode. The default setting is 10 seconds (for 0.5 mL sample) in Deep Well Mixing Mode. You might need custom the Mix time according to the sample volume.

- 
- 7 Place the new plate on the plate holder.

- 
- 8 Select **Calibrate** to calibrate the plate position. Refer to [CHAPTER 12, Calibrating the Plate Position \[With Plate Loader\]](#).

**NOTE** It is required to calibrate the plate position when adding a new plate.

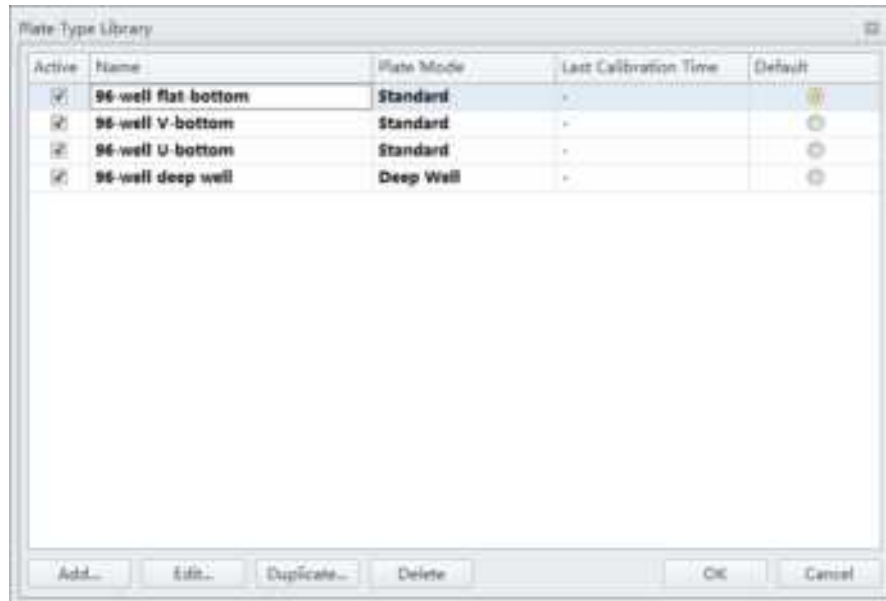
9 Select **OK**. The plate is added into the Plate Type Library.



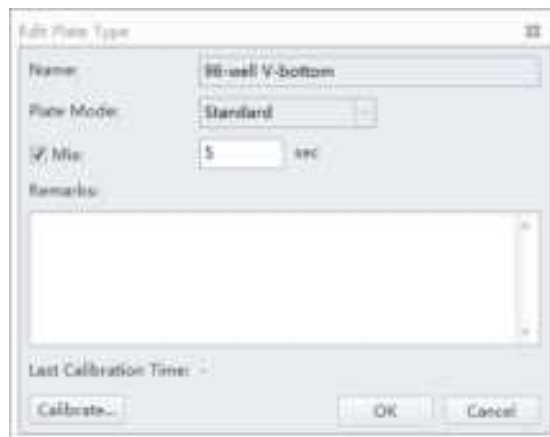
10 Select **OK**.

## Editing a Plate Type

- 1 Select **Advanced > Plate Type Library**. The Plate Type Library window appears.



- 2 Select the plate type to be edited, and select **Edit**. The Edit Plate Type window appears.



- 3 Enter the Mix setting.
- 4 **Optional:** Enter any remarks.

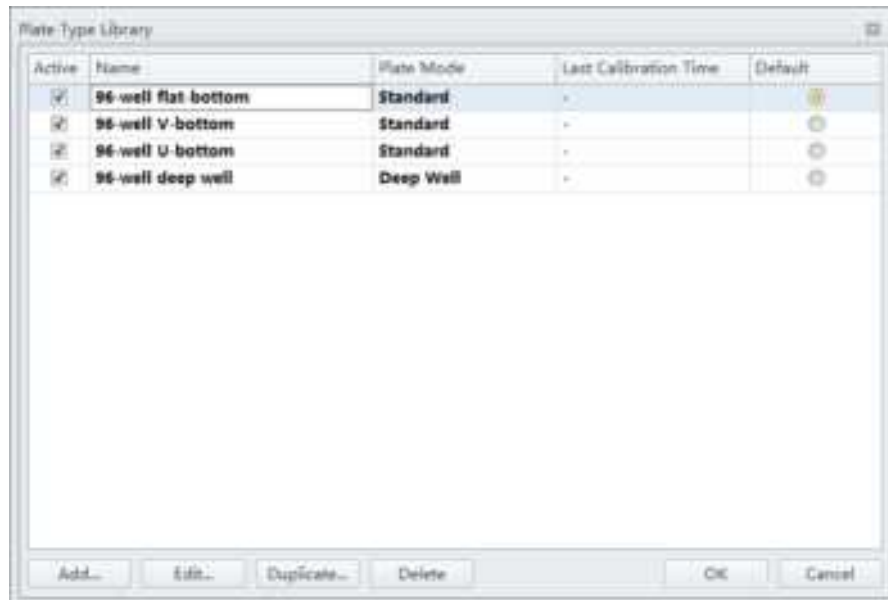
- 
- 5 Optional:** Select **Calibrate** to calibrate the plate position. Refer to [CHAPTER 12, Calibrating the Plate Position \[With Plate Loader\]](#).

The Calibration can be performed at any time.

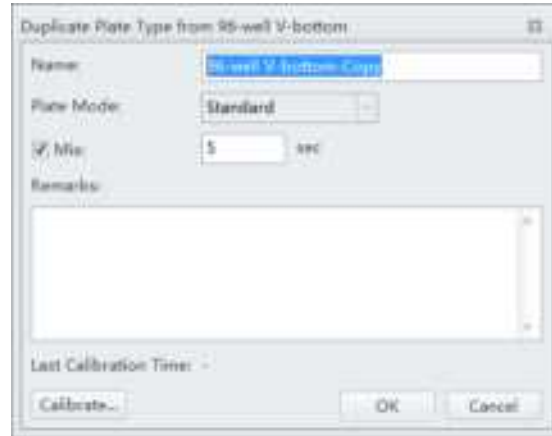
- 
- 6** Select **OK**.
- 

## Duplicating a Plate Type

- 1** Select **Advanced > Plate Type Library**. The Plate Type Library window appears.



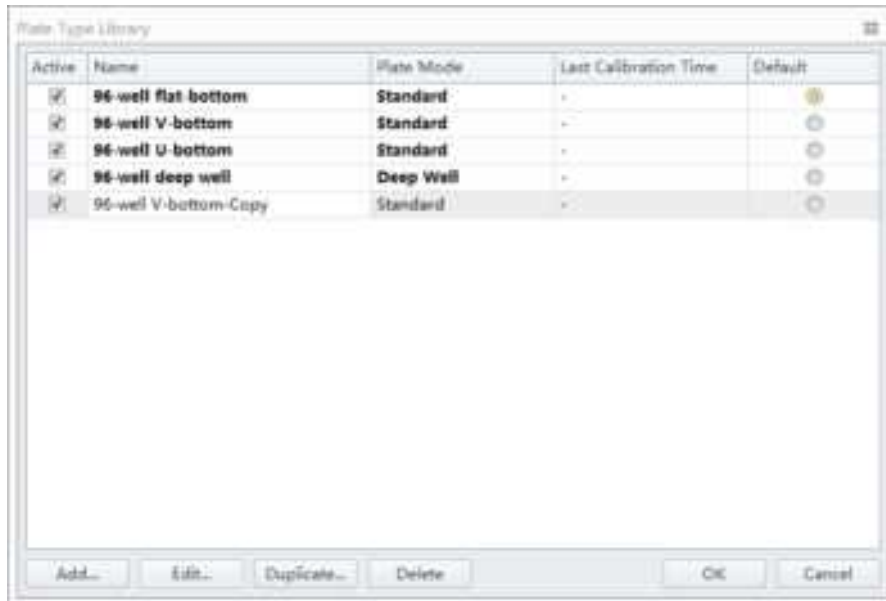
- 
- 2 Select the plate type to duplicate, and select **Duplicate**. The Duplicate Plate Type window appears.



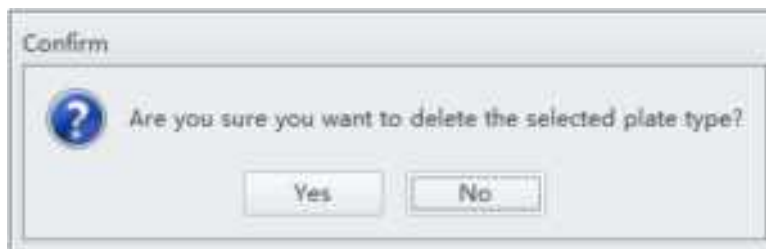
- 
- 3 Enter the Mix setting.
- 
- 4 **Optional:** Enter any remarks.
- 
- 5 **Optional:** Select **Calibrate** to calibrate the plate position. Refer to [CHAPTER 12, Calibrating the Plate Position \[With Plate Loader\]](#).  
The Calibration can be performed at any time. The duplication retains the calibration information if the original plate was already calibrated.
- 
- 6 Select **OK**.
-

## Deleting a Plate Type

- 1 Select **Advanced > Plate Type Library**. The Plate Type Library window appears.



- 2 Select the plate type to be deleted, and select **Delete**. The following message appears:



**NOTE** The default plate types, shown in bold, cannot be deleted from the Plate Type Library.

- 3 Select **Yes**. The selected plate type is removed from the Plate Type Library.

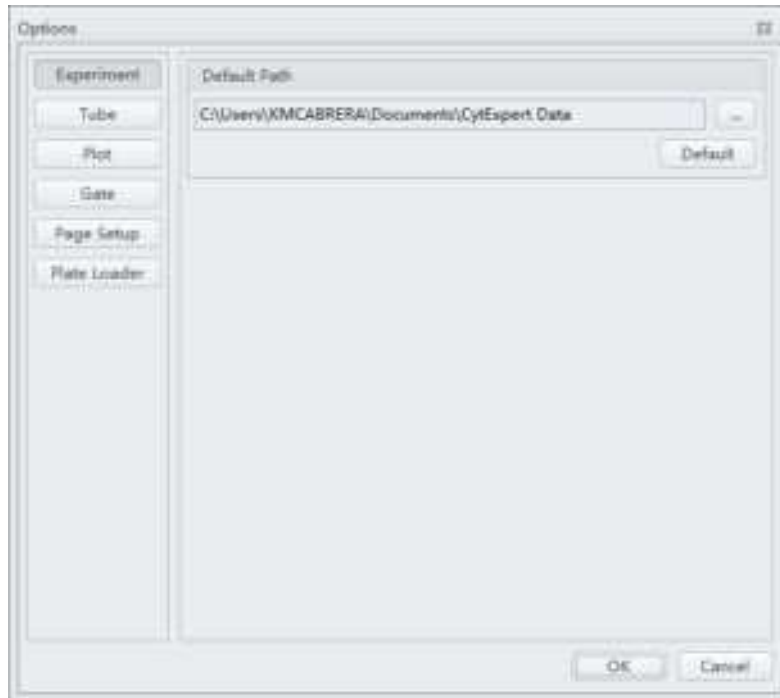
## Software Settings

---

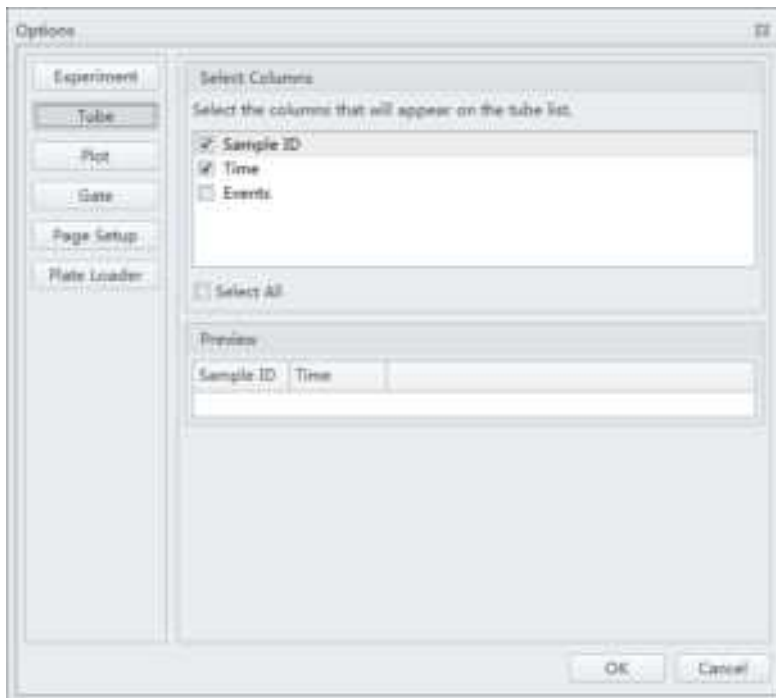
Select **Options** in the Settings menu to configure the software settings.

In the **Experiment** settings, you can set the experiment's default save path.

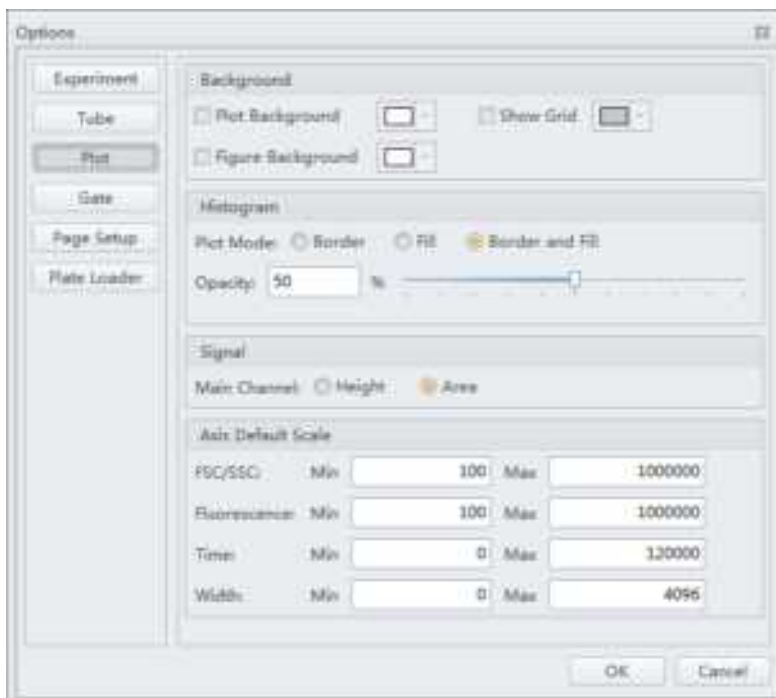
**NOTE** The Experiment setting is only available if either the CytExpert Default or the CytExpert User Management software option is installed.



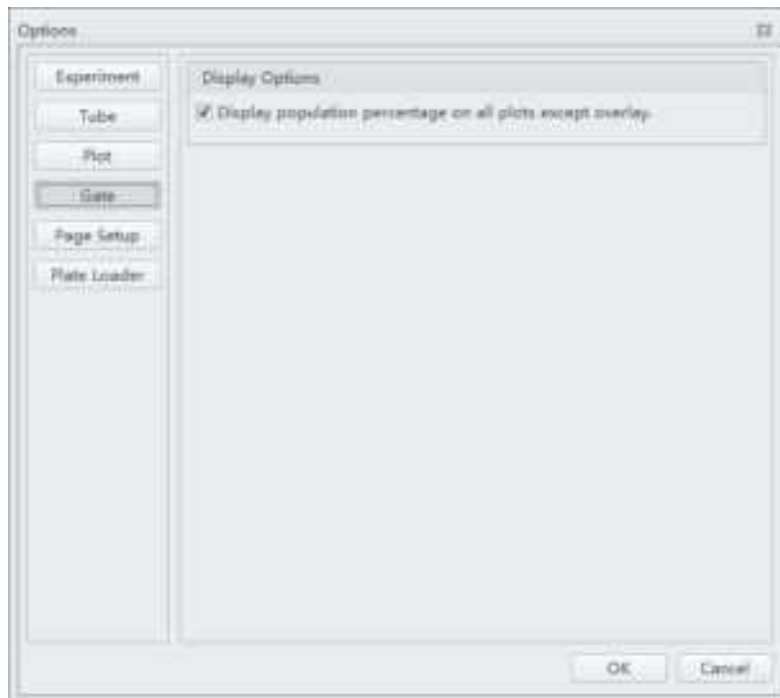
In the **Tube** settings, you can select the columns that display in the tube section of the screen.



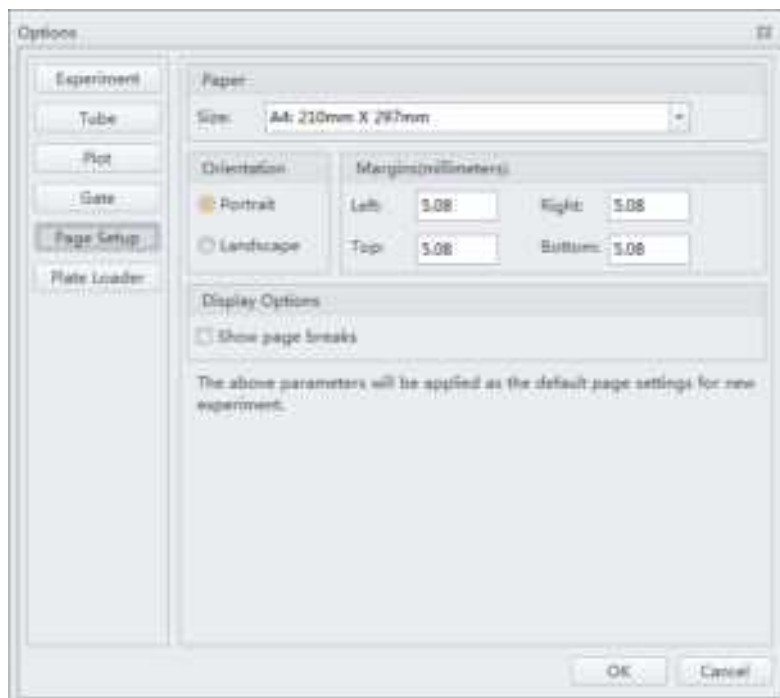
In the **Plot** settings, you can define the background of the graphics display area, configure the histograms, and set the default signal parameters to either the channel's area or the channel's height. The default is **Area**. You can also set the default axis display range.



In the **Gate** settings, you can choose to display population percentage on all plots except overlay.

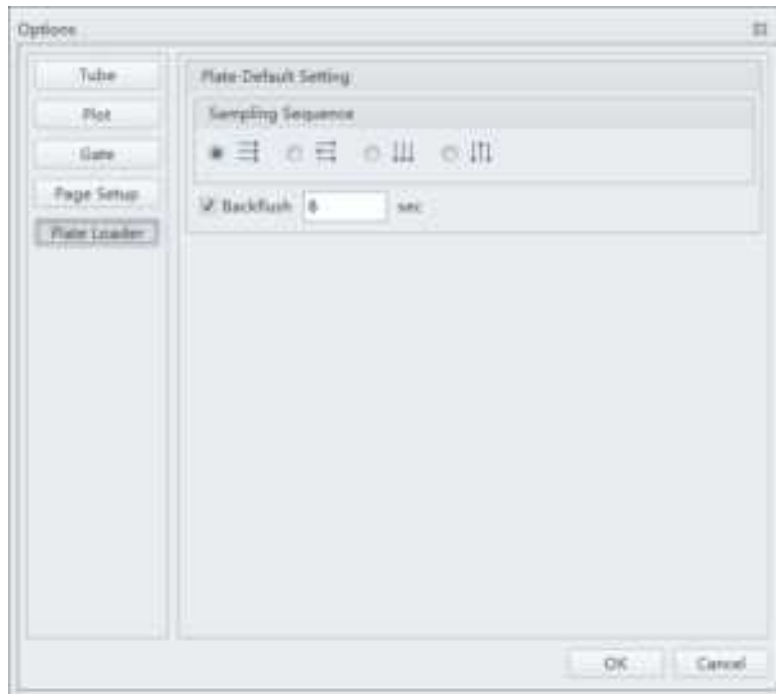


In the **Page Setup** settings, you can change the page size, orientation, margin size, and display options. Select **Show page breaks** to display page boundaries within the Acquisition or Analysis views for simplifying plot arrangement for printing.



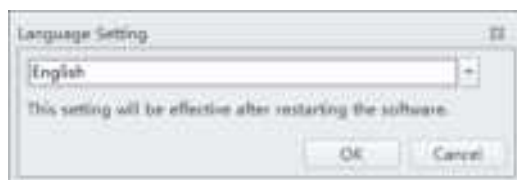
In the **Plate Loader** settings, you can select the plate type, sampling sequence, mix, and backflush settings for the plate loader.

**NOTE** This setting is only available in the Plate Loader sample injection mode.



## Language Settings

Select **Settings > Language Settings** to open the Language Settings window. In the Language Settings window, you can select which language to use for the software menus and graphical statistics. The two options currently offered are English and Simplified Chinese.



## Setting Up CytExpert Application Programming Interface (API) Test Client

The CytExpert API is available for external software to control CytoFLEX Platform. It allows external software to perform operations such as running methods and allows for basic control of the plate loader. It is also possible to report population statistics as each sample finishes. [Contact us](#) to request a copy of the CytExpert API Instructions for Use manual.

## Overview

---

This chapter explains how the Cytometer measures scattered light and fluorescence as cells pass through the laser beam.

The illustrations in this chapter are not exact representations of the inside of the Cytometer. They are for explanatory purposes only.

This chapter contains information on:

- [Sample Flow](#)
- [Laser Beam Shaping](#)
- [Cell illumination](#)
- [Light Collection, Separation and Measurement](#)
- [Signal Processing](#)
- [Data Storage](#)
- [Automated Software Features](#)
- [Parameters](#)
- [Plot Display](#)
- [Statistics](#)

## Sample Flow

---

 **CAUTION**

**Possible flow cell damage. To avoid clogging the sample probe, sample tubing or flow cell, ensure that 12 x 75 mm test tubes are free of debris before you use them.**

## Sample Loading

The system supports two ways to load sample, by sampler module (for single tube) or by plate loader (for 96-well plates).

The sampler module includes three stepper motors. A 12 VDC stepper motor (sample tube loader motor) at the bottom of the module moves (swings) the sample tube holder in/out. A 12 VDC stepper motor (sample tube lifter motor) at the top of the module moves the sample tube holder up/down, using a toothed belt. An additional 12 VDC stepper motor at the top of the module

(sample peristaltic pump motor) moves the sample peristaltic pump to achieve liquid flow. Refer to [Figure 1.12](#). The sampler module handles a sample tube as follows:

- It swings the tube holder out for loading.
- It swings the tube holder in and lifts the tube holder.
- The sample probe rates to mix the sample.
- The sample peristaltic pump starts to aspirate the sample. Sample flow begins.

The plate loader module is installed in the inner compartment of the Cytometer, as shown in [Figure 1.13](#) and [Figure 1.14](#). The plate module includes three movement modules.

- The Y-Axis movement module ejects or retracts the plate holder stage.
- The X-Axis movement module moves the probe from left to right across the plate to position the plate loader sample probe over all of the possible columns in the well plate.
- The vertical movement module supports and moves the plate loader wash station assembly up and down as needed to mix a sample in a well, aspirate a sample from a well, and clean the plate sample probe.

The sample probe is cleaned automatically when sample flow ends.

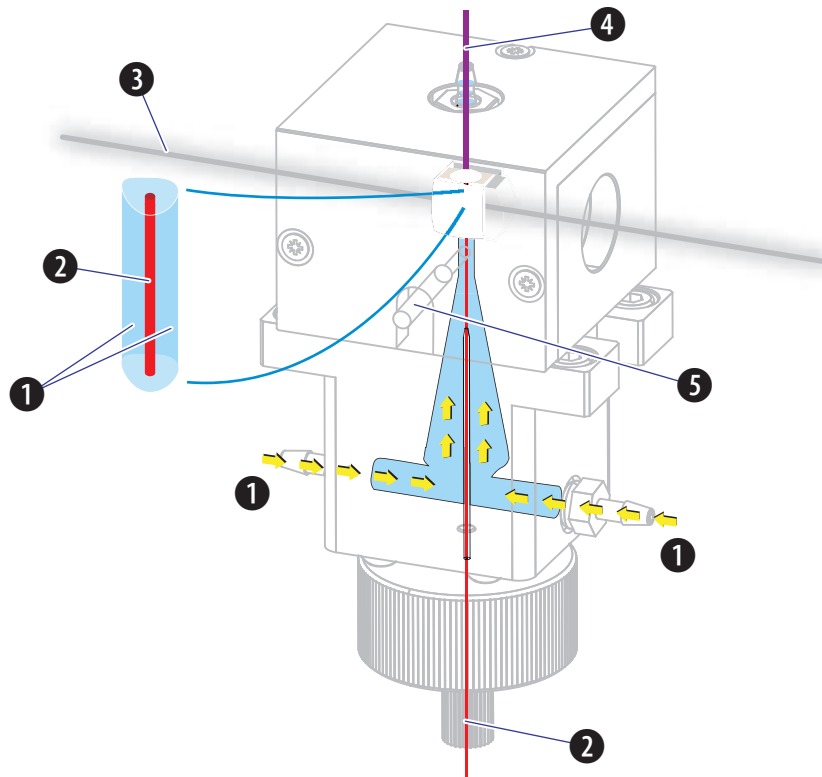
## Hydrodynamic Focusing

The instrument uses a process called hydrodynamic focusing to ensure that the cells move through the laser beam one at a time, along the same path through the flow cell.

The flow cell ([Figure 3.1](#)) contains a rectangular channel. A pressurized stream of sheath fluid enters the channel at the lower end and flows upward. The sensing area of the flow cell is at the center of the channel.

While the sheath stream is flowing through the channel, a stream of sample is injected into the middle of the sheath stream. As shown in [Figure 3.1](#), the sheath stream surrounds, but does not mix with, the sample stream. The pressure of the sheath stream focuses the sample stream so that the cells flow through the laser beam single file. If the cells were to move through the laser beam in different ways during sample flow, sample analysis could be distorted.

Figure 3.1 Flow Cell

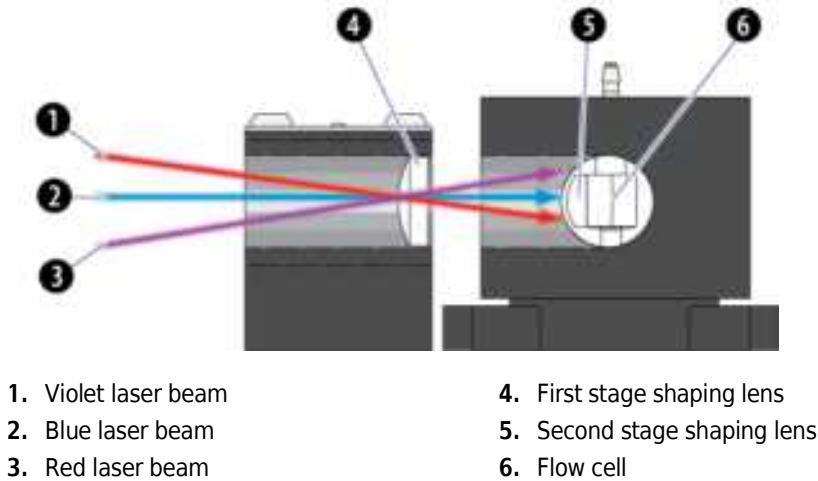


1. Sheath stream
2. Sample stream
3. Laser beam
4. Waste out
5. Purge port (Waste)

## Laser Beam Shaping

Before the laser beam reaches the sample stream, lenses focus the beam (see [Figure 3.2](#)). Focusing keeps the beam perpendicular to the sample stream flow while making the beam small enough to illuminate only one cell at a time.

Figure 3.2 Laser Beam Shaping



## Cell Illumination

---

As cells in the sample stream go through the sensing area of the flow cell, the elliptical beam illuminates them. The cells scatter the laser light and emit fluorescent light from autofluorescence and the fluorescent dyes attached to them.

### Forward Scatter

The amount of laser light scattered at narrow angles to the axis of the laser beam is called forward scatter (FS). The amount of FS is proportional to the size of the cell that scattered the laser light.

### Side Scatter and Fluorescent Light

The amount of laser light scattered at about a 90° angle to the axis of the laser beam is called side scatter (SS). The amount of SS is proportional to the granularity of the cell that scattered the laser light. For example, SS is used to differentiate between lymphocytes, monocytes, and granulocytes.

In addition to the SS, the cells emit fluorescent light (FL) at all angles to the axis of the laser beam. The instrument measures the amount of FL emitted by cells depending on the reagents used. For example, FL above the background FL is used to identify molecules, such as cell surface antigens.

## Light Collection, Separation and Measurement

---

### Forward Scatter Collection

The FALS (Forward Angle Light Scatter) detector collects scattered light from a particle that intersects with a laser and delivers information roughly proportional to the size of the particle. The

forward angle light is filtered with a 488 nm band pass before it reaches the FS sensor which generates voltage pulse signals. These signals are proportional to the amount of light the sensor receives.

## Side Scatter and Fluorescent Light Collection

Both side scatter and fluorescence are measured 90 degrees from the laser axis.

### Side Scatter

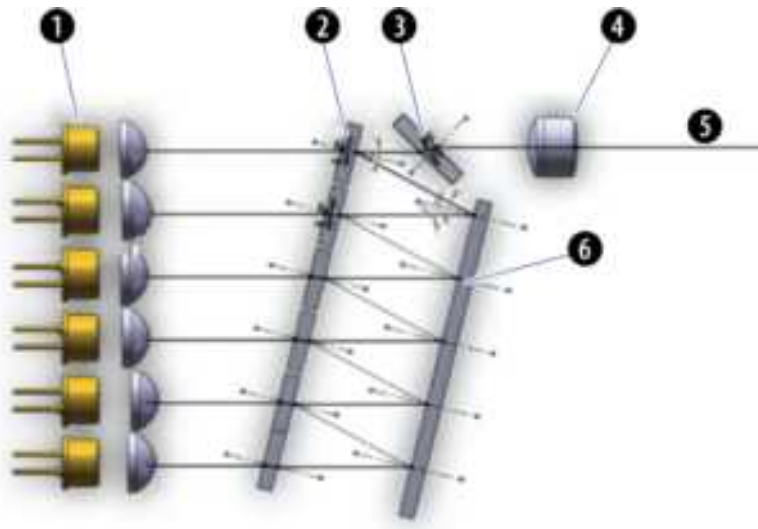
The wavelength of SS is 488 nm. It is much more intense than FL.

Side scatter light collected by the objective lens is delivered by fiber optics to a patent-pending design with high performance, solid-state, high efficiency, and low-noise detector arrays.

### Fluorescent Light

Fluorescence and scattered light are transmitted by optical fibers to the Wavelength division multiplexer (WDM). Each WDM is a unique detector array that corresponds to a different laser. Refer to [CHAPTER 1, Wavelength Division Multiplexer \(WDM\)](#). Each WDM contains optical filters and detectors for detecting channel fluorescence or scatter from a particular laser. It is necessary to ensure that the filter and software settings match for each channel.

**Figure 3.3** Light Path through the WDM with a Single Port



1. Fiber array photo detectors (FAPD)
2. Filter
3. 45-degree reflector
4. Doublet lens
5. Light path
6. Mirror

## Signal Processing

---

The CytoFLEX is a fully digital system with an active range of 7 logarithmic decades, signal collection speed of 30,000 events/second (includes 15 parameters).

## Data Storage

---

### CAUTION

The instrument Workstation is vulnerable to malware, viruses, data corruption, and unauthorized instrument setting changes, or privacy breaches if unauthorized access is gained by malicious personnel. To reduce the risk of such events, only allow authorized laboratory personnel access to the instrument Workstation. Contact your institutional security department for assistance.

### CAUTION

The instrument Workstation is vulnerable to malware and viruses from physical media such as CDs, DVDs, or USB drives. To reduce the risk of data corruption or unauthorized setting changes, only use physical media such as CDs, DVDs, or USB drives that are known to be free from viruses or malware. Contact your IT professional for assistance.

### CAUTION

The instrument Workstation is vulnerable to malware, viruses, and unauthorized access if connected to a network without using the PROService RMS hardware available from Beckman Coulter. To reduce the risk of data corruption, unauthorized instrument setting changes, or privacy breaches, only connect the instrument Workstation to a network via the PROService RMS hardware. [Contact us](#) to obtain PROService.

Sample results can be printed out, saved to removable media, saved to a local hard drive or saved to a network drive. You can store sample results in Flow Cytometry Standard (FCS 3.0) files.

## Automated Software Features

---

CytExpert for CytoFLEX software contains the following automated software features.

- **Auto Delay.** The system reads and automatically adjusts laser delay during QC. You can also read the laser delay value while acquiring samples.
- **Auto Threshold.** Easily find target populations. No need to worry about the threshold setting while adjusting gains when auto threshold is enabled.

- **Auto Gating.** There are two types of autogates available in the CytExpert for CytoFLEX software: auto line segment and auto polygon.

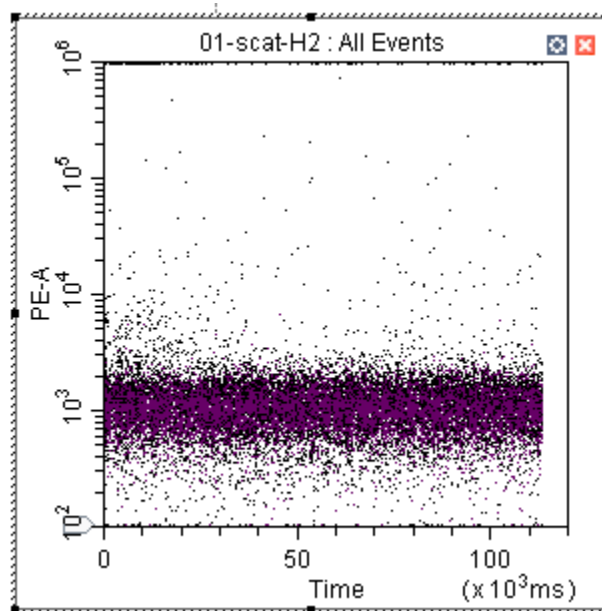
## Parameters

---

### TIME Parameter

The TIME parameter is the amount of time, in seconds, the instrument acquires data. It is displayed on the plot. The axis labels vary, depending on plot resolution and stop time (duration) if **Fit with sample** is selected.

**Figure 3.4** Time vs Fluorescence plot



### Plot Display

---

The results of sample analysis appear on the Workstation screen as graphs called plots. Refer to [CHAPTER 2, Graphic and Gating Styles](#).

## Statistics

The Statistics Setting window allows you to change the display of the header, statistical elements and cell populations included.



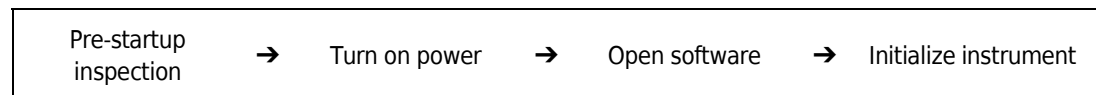
## Overview

---

**IMPORTANT** Verify that the correct USB configuration key is securely connected to a computer USB port. If the USB configuration key is not connected, the following error message appears: *CytExpert cannot find the license. Please check whether the correct USB configuration key has been plugged in.*

This chapter describes the instrument startup procedure.

Workflow:



This chapter contains information on:

- [Pre-Startup Inspection](#)
- [Turning On the Instrument](#)
- [Logging into the Software](#)
- [Initializing the Instrument](#)

## Pre-Startup Inspection

---

Before using the CytoFLEX platform flow cytometer, perform the following system checks.

## Checking Waste and Reagent Levels [4 L Fluid Containers]

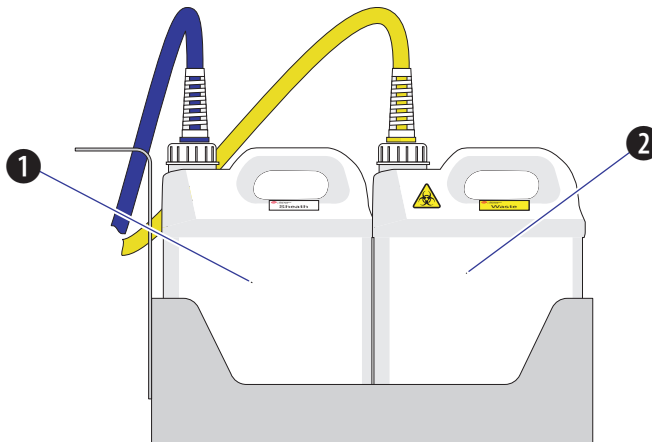


### CAUTION

**Risk of instrument damage. Do not use a saline-based sheath fluid on the CytoFLEX instrument. Saline-based sheath fluid could damage instrument components. Beckman Coulter recommends using CytoFLEX Sheath Fluid or a similar nonionic sheath fluid to ensure system performance.**

- 1 Examine the sheath fluid and waste containers. Verify that there is sufficient sheath fluid in the sheath fluid container and that the waste container is empty.

**NOTE** When the sheath fluid container is near empty or the waste container is near full, a warning message is transmitted to the Workstation and audible signals sound as a warning.



1. Sheath fluid container
2. Waste container

### CAUTION

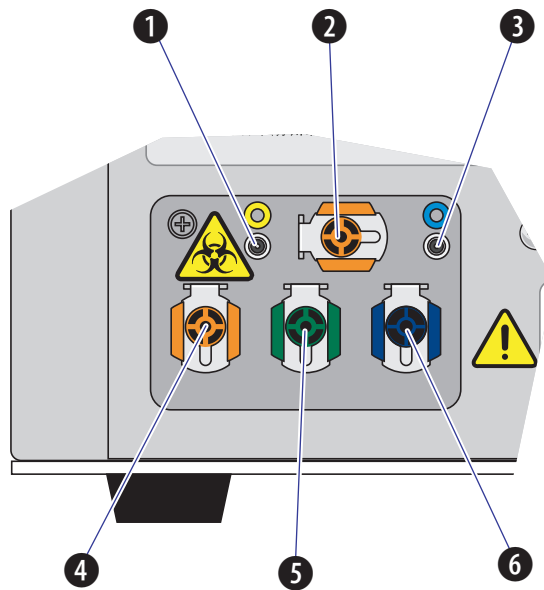
**Risk of instrument damage. Remove the sheath fluid container from the Fluid Container holder before filling the sheath fluid container to avoid damage to instrument electronics.**

- 2 If necessary, fill the sheath fluid container with CytoFLEX Sheath Fluid or a similar nonionic sheath fluid while not exceeding the maximum volume indicated (4 L). Refer to [CHAPTER 12, Filling the 4 L Sheath Fluid Container](#).

**WARNING**

**Risk of chemical injury from bleach. To avoid contact with the bleach, use barrier protection, including protective eyewear, gloves, and suitable laboratory attire. Refer to the Safety Data Sheet for details about chemical exposure before using the chemical.**

- 3 If necessary, empty all waste liquid from the waste container. If biohazardous samples are used for data collection, add 400 mL of high-quality, fragrance-free, gel-free bleach (5 to 6% solution of sodium hypochlorite - available chlorine) to the waste container. Refer to [CHAPTER 12, Emptying the 4 L Waste Container](#).
- 4 Verify that the Fluid Containers and the Cytometer are on the same level.
- 5 Verify that all sheath fluid tubing, waste tubing, and sensor cables are properly connected, as shown in the figure:



1. **Waste level sensor connector.** Connects to the waste liquid sensor cable.
2. **Flow cell waste out.** Connects to the flow cell waste tubing.
3. **Sheath fluid level sensor connector.** Connects to the sheath fluid sensor cable.
4. **Waste out.** Connects to the waste liquid tubing.
5. **Sheath return.** Connects to the sheath fluid tubing.
6. **Sheath fluid in.** Connects to the sheath fluid tubing.

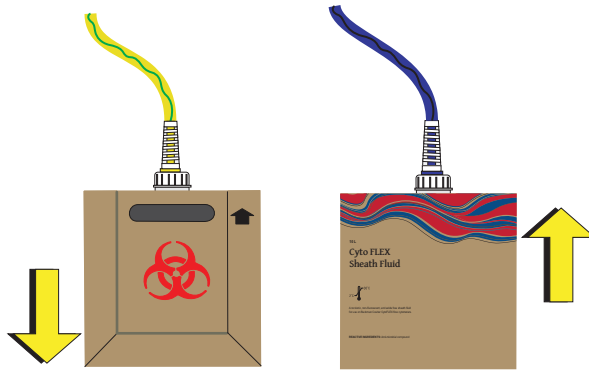
## Checking Waste and Reagent Levels [10 L Fluid Cubitainers]



**Risk of instrument damage. Do not use a saline-based sheath fluid on the CytoFLEX Platform instrument. Saline-based sheath fluid could damage instrument components. Beckman Coulter recommends using CytoFLEX Sheath Fluid or a similar nonionic sheath fluid to ensure system performance.**

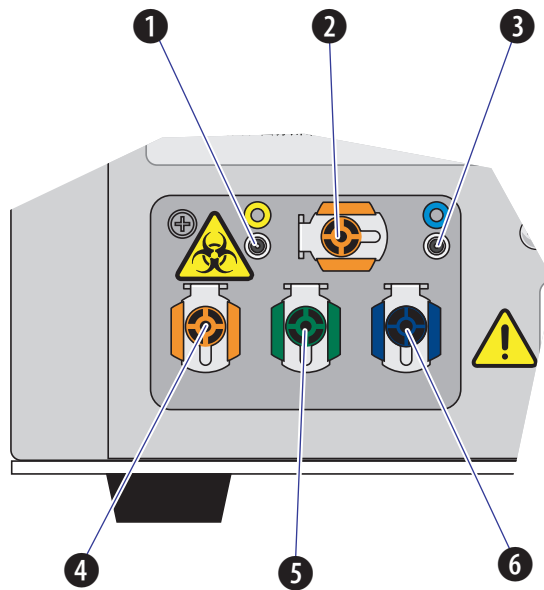
- 1 Examine the sheath fluid and waste cubitainers. Verify that there is sufficient sheath fluid in the sheath fluid container and that the waste container is empty.

**NOTE** When the sheath fluid container is near empty or the waste container is near full, a warning message is transmitted to the Workstation and audible signals sound as a warning.



- 2 Confirm that the instrument is in the standby state.
- 3 If necessary, replace the sheath fluid cubitainer with CytoFLEX Sheath Fluid or a similar nonionic sheath fluid. Refer to [CHAPTER 12, Replacing the 10 L Sheath Fluid Cubitainer](#).
- 4 If necessary, empty all waste liquid from the waste container. Refer to [CHAPTER 12, Emptying the 10 L Waste Cubitainer](#).
- 5 Verify that the Fluid Cubitainers and the Cytometer are on the same level.

- 6 Verify that all sheath fluid tubing, waste tubing, and sensor cables are properly connected, as shown in the figure:



1. **Waste level sensor connector.** Connects to the waste liquid sensor cable.
2. **Flow cell waste out.** Connects to the flow cell waste tubing.
3. **Sheath fluid level sensor connector.** Connects to the sheath fluid sensor cable.
4. **Waste out.** Connects to the waste liquid tubing.
5. **Sheath return.** Connects to the sheath fluid tubing.
6. **Sheath fluid in.** Connects to the sheath fluid tubing.

## Power Source Inspection

Check the power cable located below the power switch on the back of the Cytometer, and verify it is securely connected to both the Cytometer and the power source.

## Workstation Connections Inspection

Check that the monitor, mouse, keyboard, and the Cytometer are properly connected to the computer. Refer to [Figure 1.22](#).

## Turning On the Instrument

---


### CAUTION

1. If the Cytometer or Workstation fails to start properly, check first to see whether the power cable and connection cables are properly connected.
2. Never shut off the power or disconnect a data cable while the Cytometer is performing a task. Doing so can result in data loss or damage to the system.

- 
- 1 Turn on the main power switch located on the back of the Cytometer.
  - 2 Wait for the Cytometer to finish powering on, then turn on the Workstation.
- 

## Logging into the Software

---

- 1 Log in to the Windows operating system and double-click the CytExpert desktop icon  to open the software.

If you are running the CytExpert Default software installation, login is not required. Proceed to Step 4.

If you are running either the CytExpert User Management or the CytExpert Electronic Record Management software installation, the login window appears.

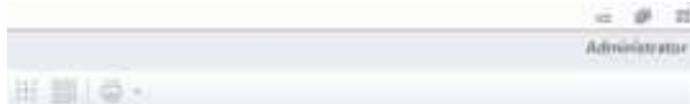


**NOTE** The default software shortcut appears on the desktop. If you do not see the icon, the default installation path is under C:/Program Files/CytExpert. Double-click CytExpert.exe to run the software.

2 Enter your username and password.

3 Select .

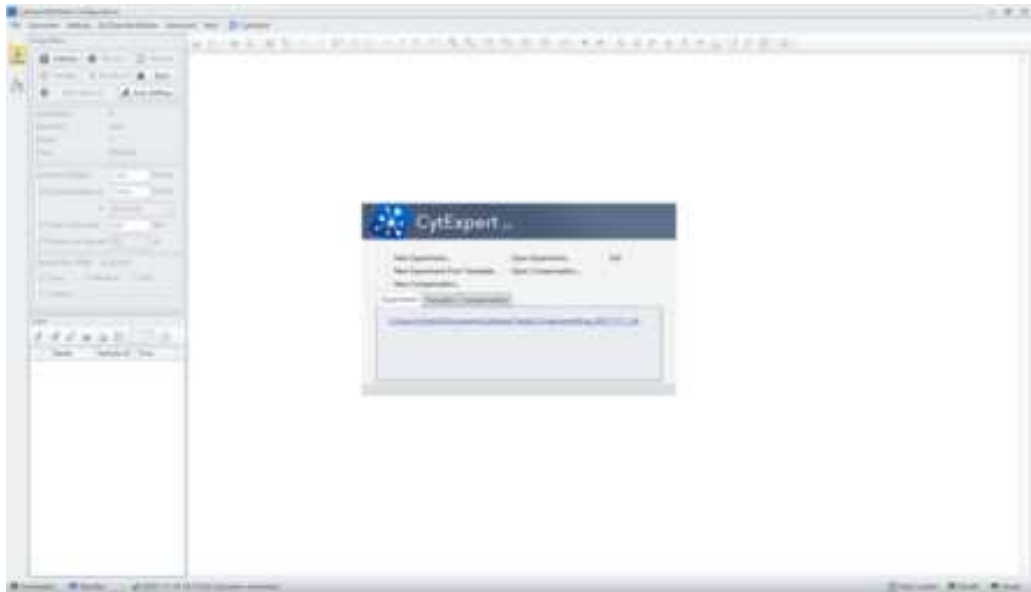
**NOTE** The display name of the user that is currently logged in displays in the top, right corner of the software screen.



4 Confirm that the software and the Cytometer are properly connected.

a. Open the software. The Startup screen appears.

**[CytExpert Electronic Record Management Software Option Shown]**



b. Verify that the connection indicator light in the lower left corner of the software screen is green, and *Connected* is displayed. The left side shows the connection status, the middle shows the instrument status, and the right side shows the status details.

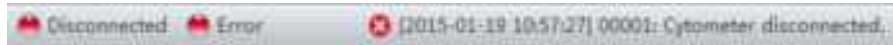


- c. Verify that the *Sheath* and *Waste* flow indicators in the lower right corner of the software screen are green indicating that the fluidics system is normal.



**NOTE**

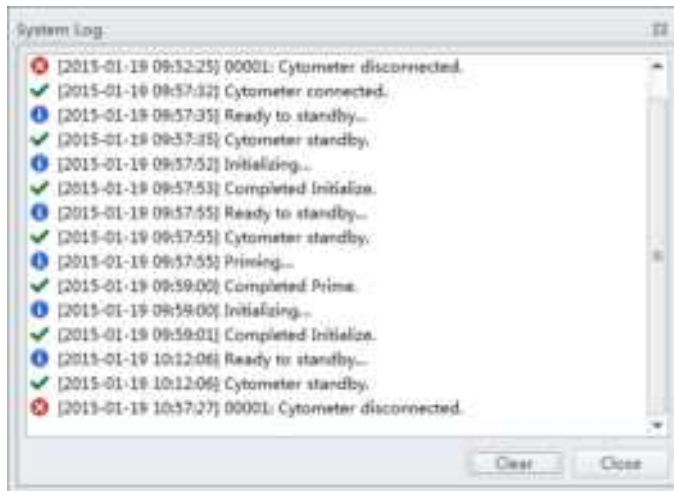
- A red connection indicator light indicates that there is a faulty connection. Ensure that the instrument is properly turned on and connected. If necessary, restart both the Cytometer and the Workstation.



- After the instrument initializes, a warning beep sounds if there is a problem with the fluidics system. If a flow indicator is red and blinking, it means that the fluidics system requires attention.



- When the waste fluid sensor is disconnected, the waste flow indicator shows that the waste container is full or nearly full.
- Select the status information in the lower left to open the system log. Send a copy of the system log to your Beckman Coulter Representative for support if a service call is requested.



## Logging Out of the Software

If you have the CytExpert User Management or the CytExpert Electronic Record Management software option installed, select the username displayed in the top-right corner of the software screen and select **Log out**.



If you have the CytExpert Default software option installed, log out is not required. Select **File > Exit** to close the CytExpert software.

## Locking the Account

If you have the CytExpert User Management or the CytExpert Electronic Record Management software option installed, select the username displayed in the top-right corner of the software screen and select .



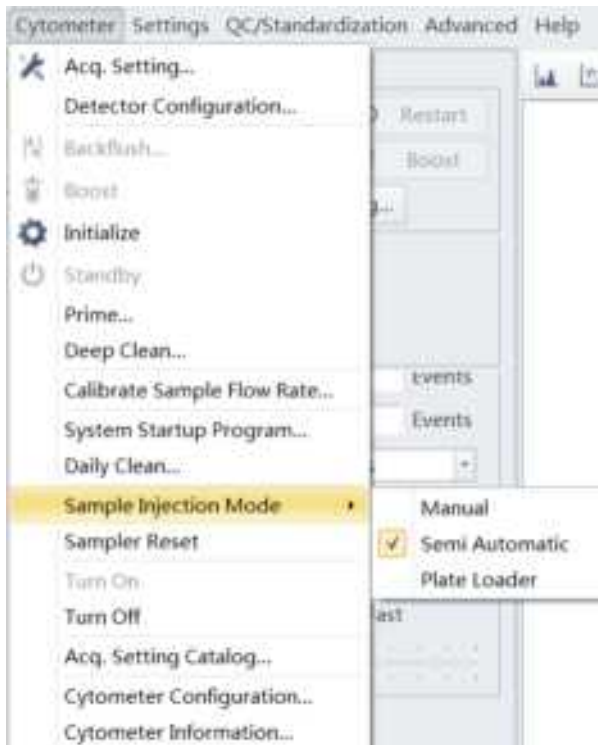
The account locks automatically if it remains inactive for a specified duration. Refer to [CHAPTER 2, Account Policies - Application Inactivity Policies](#).

## Selecting the Proper Sample Injection Mode



Select **Sample injection Mode** in the Cytometer Menu to change between the Semi-Automatic Injection mode and the Manual Injection mode. The Semi-Automatic Injection mode is recommended under most circumstances. The Manual Injection mode can be used for two

purposes: running 1.5 mL and 2 mL microcentrifuge sample tubes and a backup mode that allows you to continue to collect data if the Semi-Automatic Injection mode is not working correctly.



## Using Semi-Automatic Injection Mode

- 1 Select **Sample Injection Mode > Semi-Automatic** in the Cytometer menu to change the Sample Injection mode selection. The sampler status icon located in the bottom right side of the screen changes to display *Semi-automatic Sampler*.



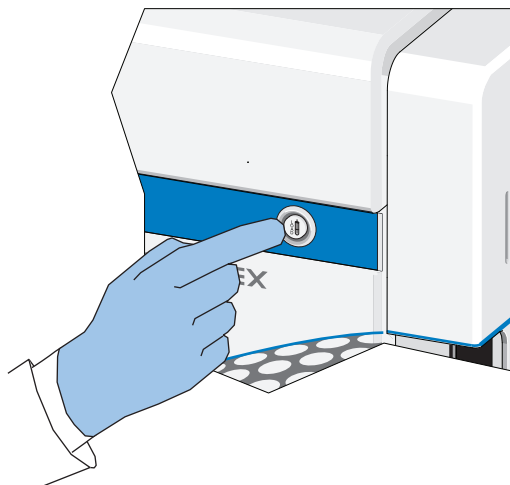
- 2 Select **Initialize**. The sample tube holder swings out from the standby position to the sample loading position (see [Figure 1.12](#)) so that you can load the sample tube.

**NOTE** You can also swing out the sample tube holder manually, load the sample tube, then select **Initialize**.

- 3 Select **Run**. The sample tube holder automatically swings back to the standby position and raises the sample tube to the sample acquisition position (see [Figure 1.12](#)), where the instrument mixes the sample and transfers the sample to the flow cell.

At the flow cell, the sample runs at the designated flow rate and the Cytometer begins to acquire data.

**NOTE** You can also push the load button on the front of the instrument to automatically start the run and record the data.



- 4 When you are satisfied with the data, select **Record** to record the data.
- 5 Wait for the data acquisition to finish or select **Stop**. The sample tube holder automatically lowers the sample tube and moves it to the sample loading position (see [Figure 1.12](#)) and the Cytometer backflushes the sample probe.

 **WARNING**

**Risk of biohazardous contamination. When using 1.5 mL and/or 2 mL sample tubes, always cut the cap off and do not exceed 300  $\mu$ L sample volume. Running samples with a cap attached to the sample tube or with volumes exceeding 300  $\mu$ L can result in sample splashing.**

### Using Manual Injection Mode

- 1 Select **Sample Injection Mode > Manual** in the Cytometer menu to change the Sample Injection mode selection. The sampler status icon located in the bottom right side of the screen changes to display *Manual Sampler*.



- 2 Manually swing the sample tube holder out from the standby position to the sample loading position (see [Figure 1.12](#)).

- 
- 3 Select **Initialize**.

---

  - 4 Load the sample tube.  
**NOTE** The sample tube holder accommodates 1.5 mL, 2.0 mL, and 12 x 75 mm sample tubes.

---

  - 5 Manually swing the sample tube holder gently back to the standby position (see [Figure 1.12](#)).

---

  - 6 Manually raise the sample tube holder gently to the sample acquisition position (see [Figure 1.12](#)) and hold the tube in that position.

---

  - 7 Select **Boost** to transfer the sample to the flow cell.

---

  - 8 Select **Run**.  
The sample runs at the designated flow rate and the Cytometer begins to acquire data.

---

  - 9 When you are satisfied with the data, select **Record** to record the data.

---

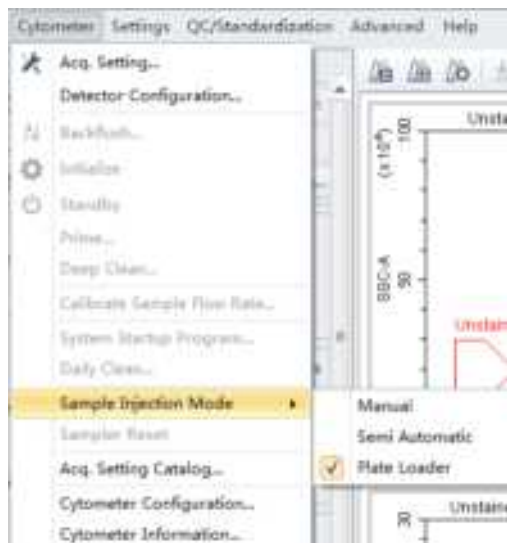
  - 10 Wait for the data acquisition to finish or select **Stop**. Then, manually lower the sample tube holder and move it to the sample loading position (see [Figure 1.12](#)).

---

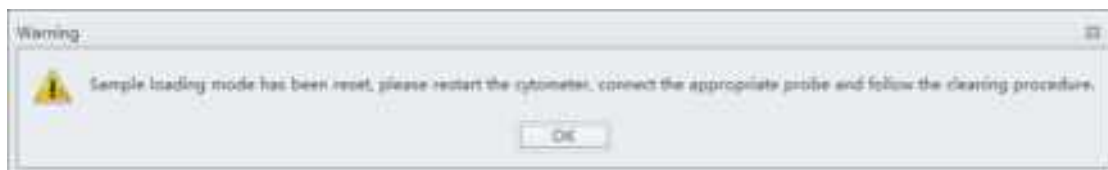
  - 11 Select **Backflush** to clean the probe.
- 

## Selecting the Plate Loader Sample Injection Mode [With Plate Loader]

Select **Sample Injection Mode** in the Cytometer Menu to change between the Semi-Automatic Injection mode, the Manual Injection mode, and the Plate Loader Injection mode. The Plate Loader Injection mode can be used for running small volumes using the following plates: 96-well flat-bottom, 96-well V-bottom, and 96-well U-bottom.

**[CytoFLEX Shown]****Using Plate Loader Injection Mode**

- 1 Select **Sample Injection Mode > Plate Loader** in the Cytometer menu to change the Sample Injection mode selection.
- 2 The restart warning prompt appears on screen. Select **OK**.



**NOTE** The restart warning only appears when switching to and from the Plate Loader sample injection mode.

- 3 Turn the Cytometer's main power switch off.

**NOTE** If you have a CytoFLEX LX instrument, you can turn the Cytometer's power off by selecting **Cytometer > Turn Off**.

**IMPORTANT** If you have the Sample Injection Mode Control Kit installed on your CytoFLEX Platform instrument, refer to [APPENDIX C, Sample Injection Mode Control Kit](#) for detailed instructions on switching from the single tube sample probe to the Plate Loader.

- 4 Remove the single tube sample probe and replace it with the plate loader PEEK tubing. Refer to [CHAPTER 12, Changing the Sample Probe from the Plate Loader to the Single Tube Sample Station \[CytoFLEX With Plate Loader\]](#).

- 
- 5 Turn the Cytometer's main power switch on.

The sampler status icon located in the bottom right side of the screen changes to display *Plate Loader*.



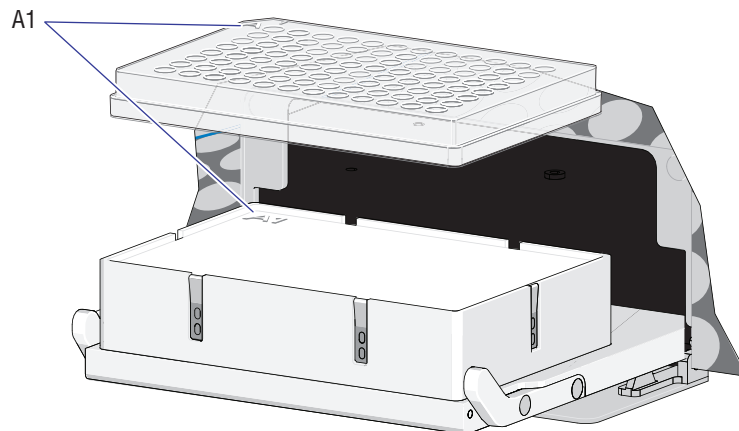
**NOTE** If you have a CytoFLEX LX instrument, you can turn the Cytometer's power on by selecting **Cytometer > Turn On**.

- 
- 6 Select **Initialize**.

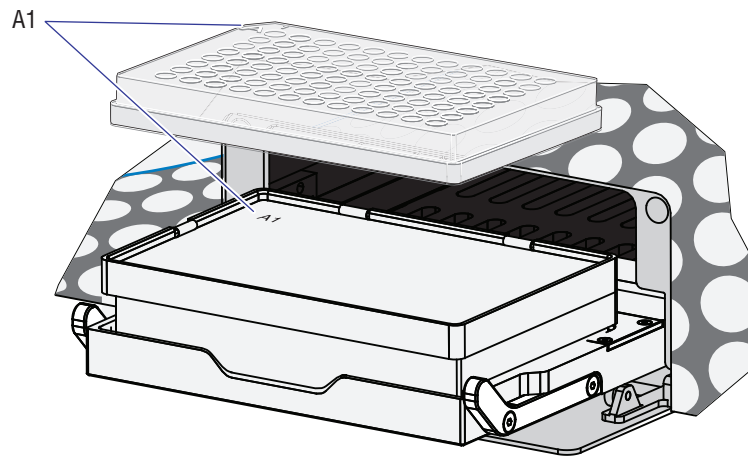
- 
- 7 Select **Eject**.

- 
- 8 Place the plate flat on the plate holder and ensure that it is secure.

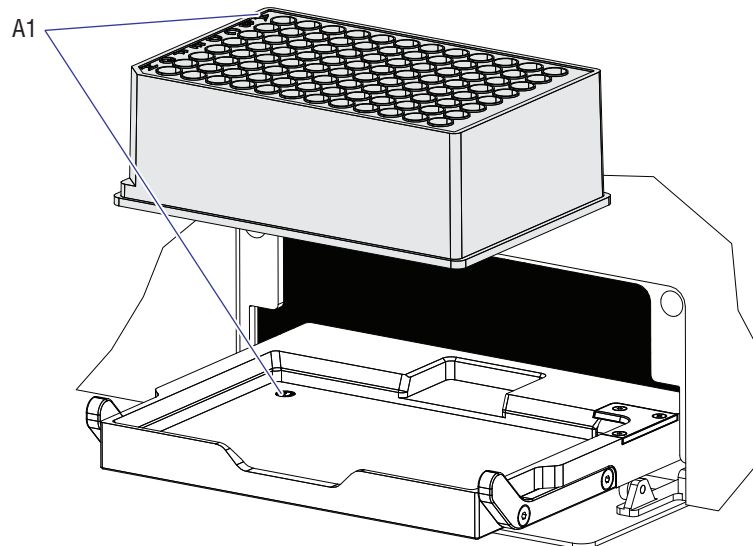
**[Standard 96-Well Plate in the Plate Holder (Without Groove)]**



**[Standard 96-Well Plate in the Plate Holder (With Groove)]**



**[96-Well Deep Well Plate Only]**



**NOTE** Ensure that plate well A1 aligns with position A1 on the plate holder.

---

**9** Select **Load** to load the plate.

---

**10** Select **Run**. The plate loader automatically loads the plate holder stage and begins to acquire data.

---

**11** When you are satisfied with the data, select **Record** to record the data.

---

**12** Wait for the data acquisition to finish or select **Stop**. The Cytometer backflushes the sample probe.

---

**13** Select **Eject** to eject the sample loader.

---

## Running the System Startup Program [with the Single Tube Loader]

**IMPORTANT** Instructions on the software window vary depending on whether you are in semi-automatic injection mode or manual injection mode.

The system startup program takes approximately 10 minutes if the fluidic self-check is enabled. The system startup program takes approximately 8 minutes if the fluidic self-check is not enabled.

**NOTE** The fluidic self-check is an optional feature only available when the sheath damper upgrade is implemented.

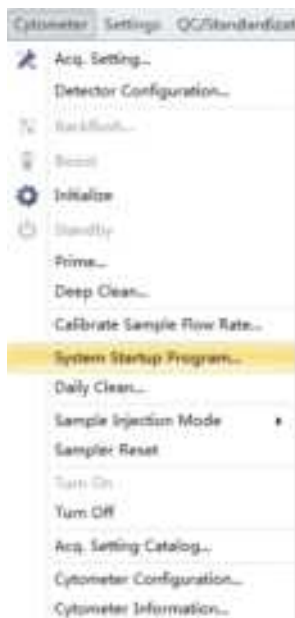
---

**1** Select **Initialize**.

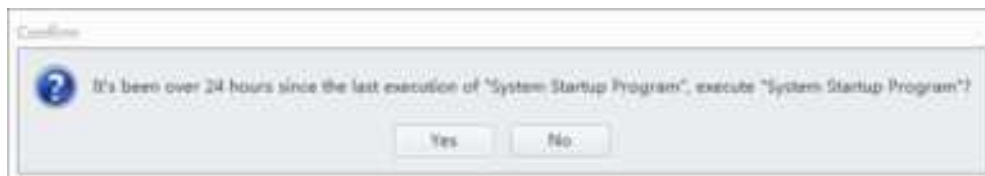
---

**2** Select **System Startup Program** in the Cytometer menu.

[CytoFLEX LX Shown]

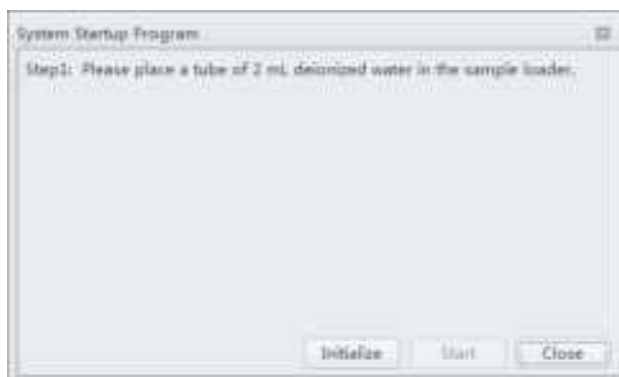


- 3 If the confirm window appears, select **Yes**.



- 4 The System Startup Program window appears. Select **Initialize**.

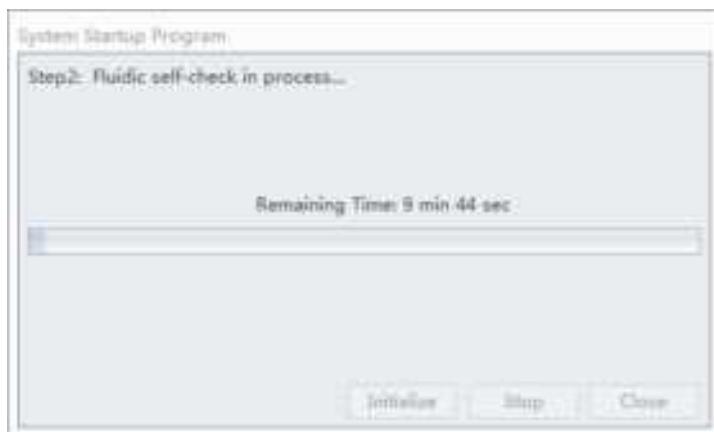
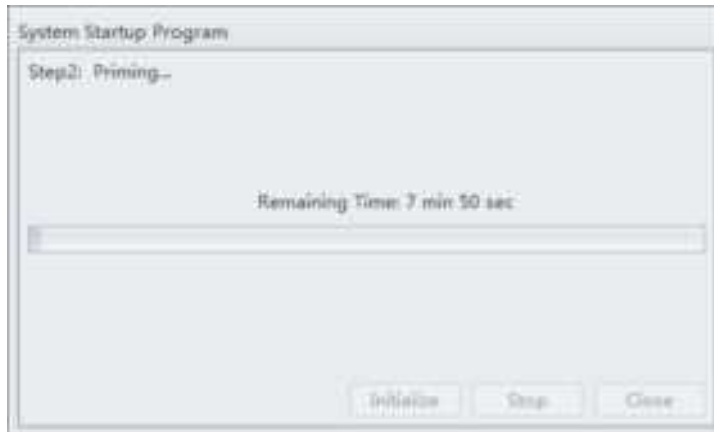
#### System Startup Program Window in Semi-Automatic Injection Mode



#### System Startup Program Window in Manual Injection Mode



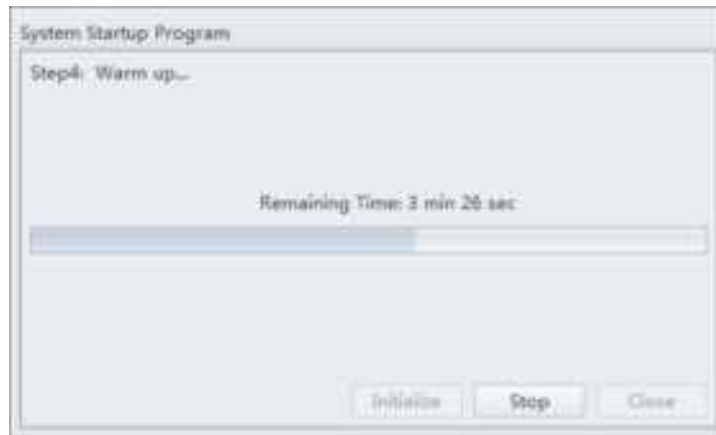
- 5 Wait for the system to initialize. Follow the on screen software prompts, then select **Start**.  
The instrument begins to prime or run the fluidic self-check. This process takes about 4 minutes if the fluidic self-check is enabled. This process takes about 1 minute if the fluidic self-check is not enabled.



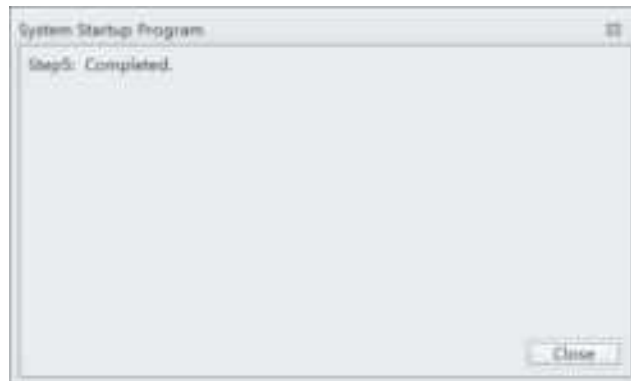
After priming or running the fluidic self-check, the system initializes again. The sample is loaded automatically. This process takes about 3 minutes.



The sample tube is unloaded after sample acquisition has finished. The system uses the remaining time to warm up.



- 6 When warm up is finished, select **Close** to quit the startup program. The system is now initialized.



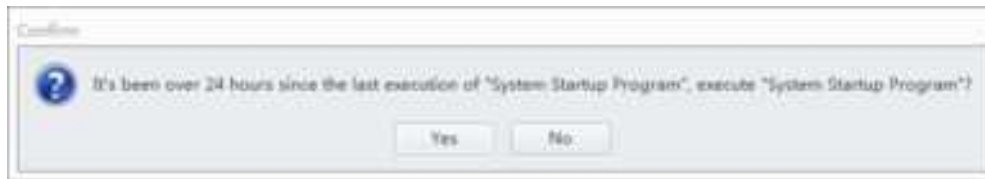
## Running the System Startup Program [With Plate Loader]

The system startup program takes approximately 10 minutes if the fluidic self-check is enabled. The system startup program takes approximately 8 minutes if the fluidic self-check is not enabled.

**NOTE** The fluidic self-check is an optional feature only available when the sheath damper upgrade is implemented.

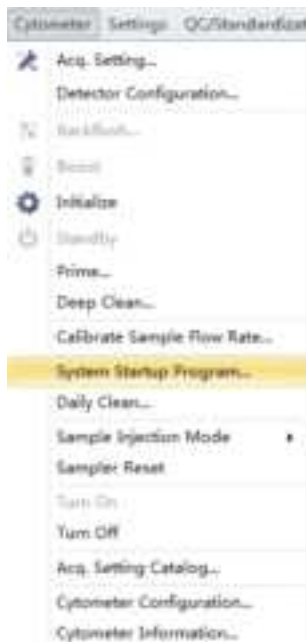
- 1 Select **Initialize**.

- 2 If the confirm window appears, select **Yes**.



- 3 Select **System Startup Program** from the Cytometer menu to open the System Startup Program window.

[CytoFLEX LX Shown]



The plate loader automatically ejects the plate holder stage and the System Startup Program window appears.

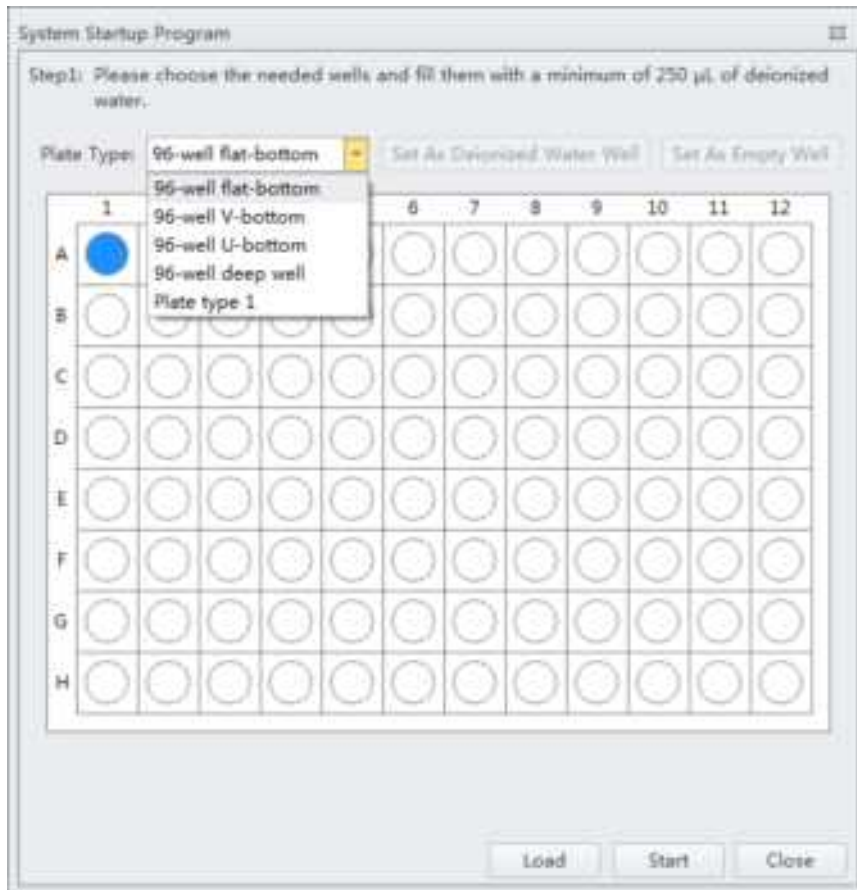
System Startup Program ☒

Step1: Please choose the needed wells and fill them with a minimum of 250  $\mu$ L of deionized water.

Plate Type:

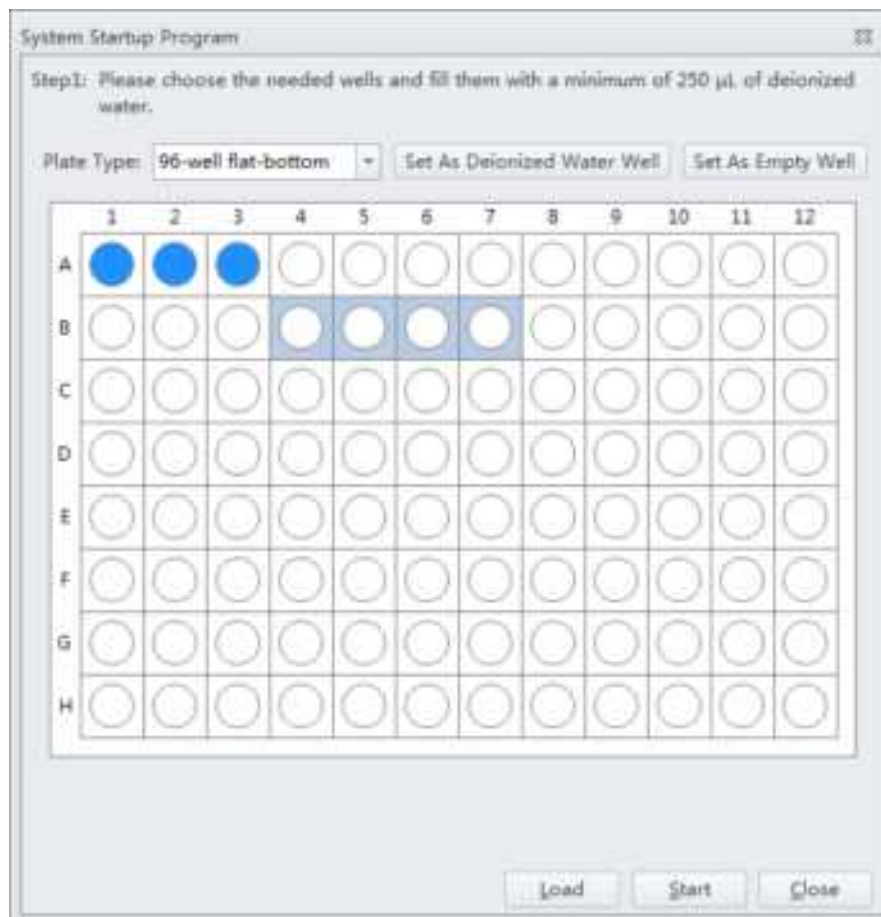
	1	2	3	4	5	6	7	8	9	10	11	12
A	<input checked="" type="radio"/>	<input checked="" type="radio"/>	<input checked="" type="radio"/>	<input type="radio"/>	<input type="radio"/>	<input type="radio"/>	<input type="radio"/>	<input type="radio"/>	<input type="radio"/>	<input type="radio"/>	<input type="radio"/>	<input type="radio"/>
B	<input type="radio"/>	<input type="radio"/>	<input type="radio"/>	<input type="radio"/>	<input type="radio"/>	<input type="radio"/>	<input type="radio"/>	<input type="radio"/>	<input type="radio"/>	<input type="radio"/>	<input type="radio"/>	<input type="radio"/>
C	<input type="radio"/>	<input type="radio"/>	<input type="radio"/>	<input type="radio"/>	<input type="radio"/>	<input type="radio"/>	<input type="radio"/>	<input type="radio"/>	<input type="radio"/>	<input type="radio"/>	<input type="radio"/>	<input type="radio"/>
D	<input type="radio"/>	<input type="radio"/>	<input type="radio"/>	<input type="radio"/>	<input type="radio"/>	<input type="radio"/>	<input type="radio"/>	<input type="radio"/>	<input type="radio"/>	<input type="radio"/>	<input type="radio"/>	<input type="radio"/>
E	<input type="radio"/>	<input type="radio"/>	<input type="radio"/>	<input type="radio"/>	<input type="radio"/>	<input type="radio"/>	<input type="radio"/>	<input type="radio"/>	<input type="radio"/>	<input type="radio"/>	<input type="radio"/>	<input type="radio"/>
F	<input type="radio"/>	<input type="radio"/>	<input type="radio"/>	<input type="radio"/>	<input type="radio"/>	<input type="radio"/>	<input type="radio"/>	<input type="radio"/>	<input type="radio"/>	<input type="radio"/>	<input type="radio"/>	<input type="radio"/>
G	<input type="radio"/>	<input type="radio"/>	<input type="radio"/>	<input type="radio"/>	<input type="radio"/>	<input type="radio"/>	<input type="radio"/>	<input type="radio"/>	<input type="radio"/>	<input type="radio"/>	<input type="radio"/>	<input type="radio"/>
H	<input type="radio"/>	<input type="radio"/>	<input type="radio"/>	<input type="radio"/>	<input type="radio"/>	<input type="radio"/>	<input type="radio"/>	<input type="radio"/>	<input type="radio"/>	<input type="radio"/>	<input type="radio"/>	<input type="radio"/>

- 4 Select the desired plate type from the Plate Type drop-down menu.



**NOTE** The available plate types included in the drop-down menu depend on the settings selected in the Plate Library. To activate a plate type, refer to [CHAPTER 2, Plate Type Library](#).

- 5 Follow the on screen software prompts and select the desired wells and select **Set As Deionized Water Well**.



**NOTE** To deselect water wells, select the desired well and select **Set As Empty Well**.

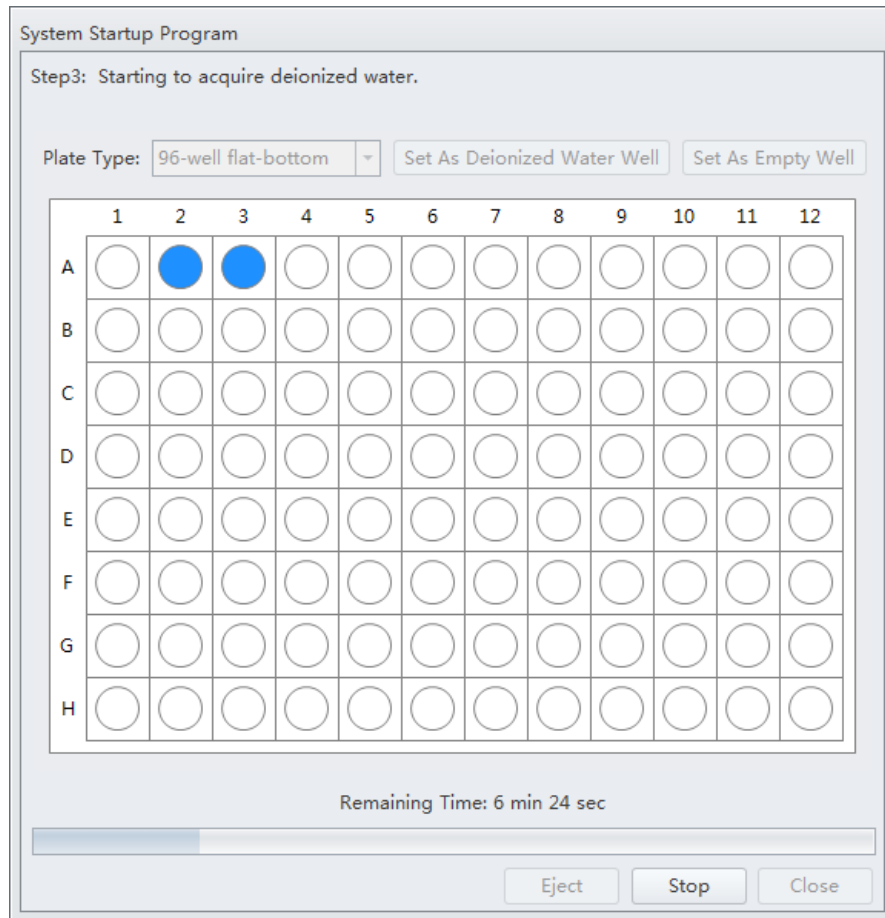
**NOTE** Prepare two to six sample wells with deionized water.

- 6 Select **Load** to load the plate.
- 7 Select **Start** to start the program. The message *Please confirm that the correct plate is placed properly and press OK* appears. Select **OK**.

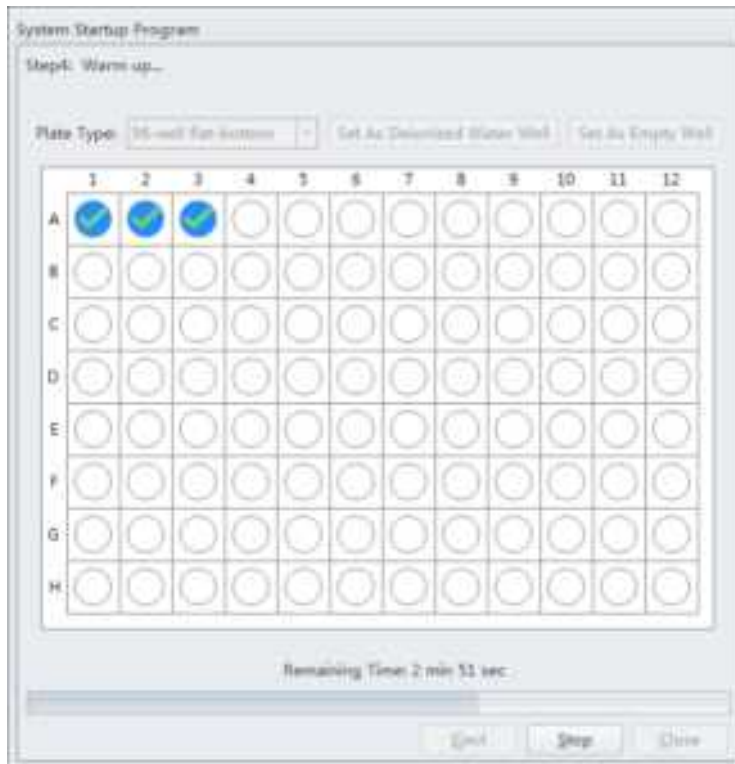
Wait for the system to initialize. The instrument begins prime or run the fluidic self-check. This process takes about 1 minute if the fluidic self-check is not enabled. This process takes about 4 minutes if the fluidic self-check is enabled.



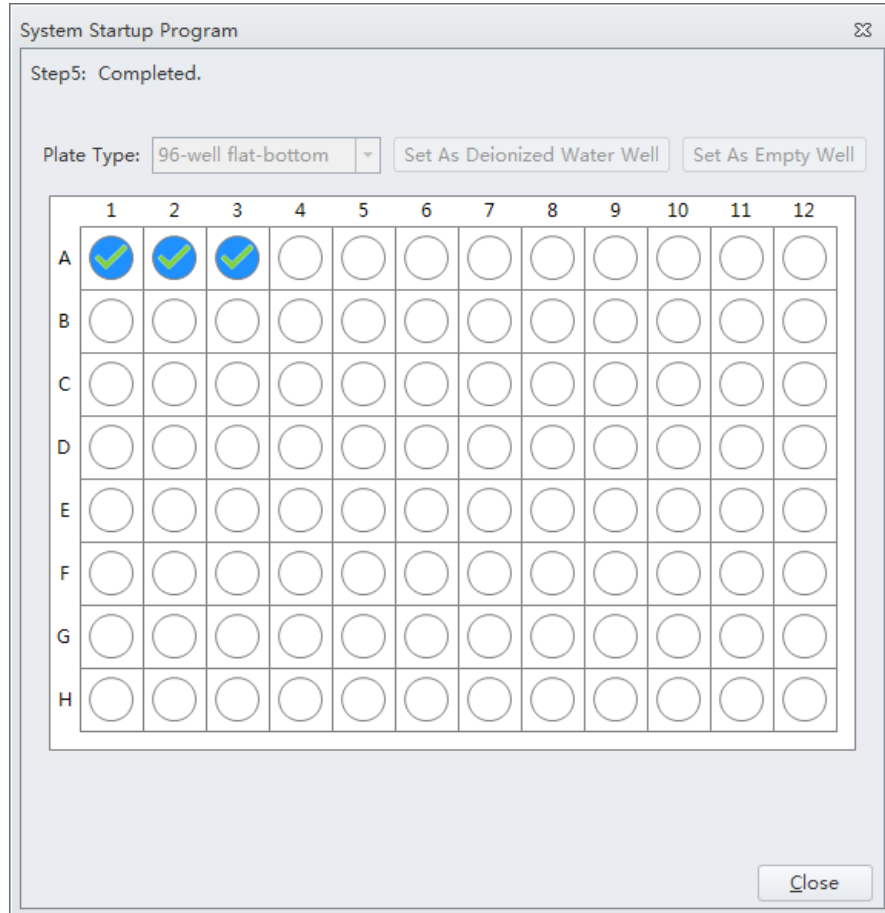
After priming or running the fluidic self-check, the system initializes again. The sample is loaded automatically. This process takes about 1 minute per well.



When the system finishes acquiring the selected sample well, it uses the remaining time to warm up.



- 8 When warm up is complete the plate loader ejects the plate holder stage. Select **Close** to quit the startup program. The system is now initialized.



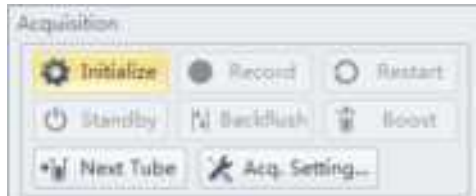
## Selecting Experiments from the Start Page

Refer to [CHAPTER 2, Start Page](#).

## Initializing the Instrument

---

- 1 Select **Initialize** in the Data Acquisition Control screen or select **Initialize** in the Cytometer Menu to initialize the instrument.



**NOTE** The system prompts you to initialize if the instrument remains in standby for over 24 hours.

**NOTE** If the instrument is in Semi-Automatic Injection mode during the initialization process, the sample tube holder automatically shifts into the sample loading position (see [Figure 1.12](#)).

- 2 Wait for the beep indicating that the instrument properly initialized.

**NOTE** In the initialized state, the enabled lasers power on to achieve operating status, and the sheath fluid flows. Refer to [CHAPTER 6, Laser Settings](#).

- If you need to execute a task with the Fluid Containers, do so with the instrument in standby state.
- If the instrument remains idle for 10 minutes, the Cytometer automatically enters the standby state.

**NOTE** After approximately 30 seconds, there should be a continuous flow of waste liquid from the Cytometer to the waste container.

- 3 Proceed to the subsequent operations or select **Standby** to put the instrument in standby state.



# Instrument Quality Control and Standardization

## Overview

---

This chapter provides information on performing daily Quality Control (QC) on the CytoFLEX flow cytometer and how to confirm that the instrument is working properly within the specified parameters. Quality Control allows you to determine whether your instrument can provide adequate signal strength and precision.

This chapter also provides information on performing standardization. CytoFLEX Daily QC Fluorospheres, CytoFLEX Ready to Use Daily QC Fluorospheres, CytoFLEX Daily IR QC Fluorospheres or any other reference material that is relevant for your application(s) may be used as the standardization sample(s). The system can only recognize a single peak.

Standardization can be used to monitor the Median Fluorescent Intensities (MFI), or target values for scatter and fluorescent parameters that have been defined and optimized for a specific application. All channels in the current configuration, those with/without an assigned QC target, can be tracked as necessary via Standardization since this portion of the CytExpert Software is used to assess application specific settings. Standardization, however, does NOT replace QC as the Cytometer's optical alignment (rCV statistical analysis), Laser Power and Laser Delay outputs are not measured during the run.

**NOTE** Beckman Coulter recommends performing QC on a daily basis.

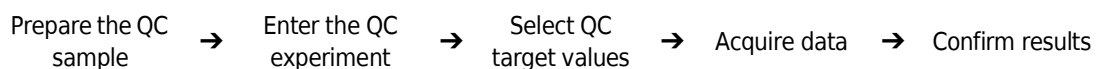
**NOTE** QC target values apply exclusively to standard channels. A channel is a laser-filter combination. Refer to [CHAPTER 6, Verifying, Selecting, Editing, and Creating Detector Configuration](#) to verify that the default factory detector configuration is selected before running QC.

**NOTE** CytExpert QC includes an automated QC routine with Levey-Jennings (LJ) charts tracking and logging.

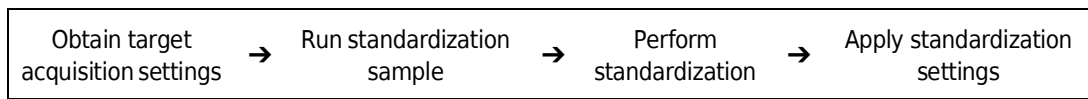
**NOTE** CytExpert Standardization allows for application-specific settings to be established and applied to future experiments.

**NOTE** Perform QC on the same day prior to performing the CytExpert standardization.

QC Workflow:



Standardization Workflow:



This chapter contains information on:

- [Preparing the QC Sample](#)
- [Preparing the QC Sample \[With Plate Loader\]](#)
- [Importing Lot-Specific Target Values](#)
- [Collecting QC Data](#)
- [Collecting QC Data \[With Plate Loader\]](#)
- [Confirming Results](#)
- [Preparing the Standardization Sample](#)
- [Generating Target Median Values](#)
- [Adding a New Standardization Item](#)
- [Performing the Standardization](#)
- [Applying the Standardized Acquisition Settings](#)
- [Standardization Target Library](#)

## Quality Control

---

The QC process verifies important system functions. The system:

1. Verifies that the unit hardware configuration matches the default configuration specified in the software. Refer to [CHAPTER 6, Verifying, Selecting, Editing, and Creating Detector Configuration](#).
2. Measures the laser power of each individual laser and ensures that each laser meets the system specifications.
3. Loads the QC sample and begins to acquire data.
4. Verifies that the actual laser delays match those set in the software and will adjust the delay accordingly.
5. Notifies you if laser delay is  $>2 \mu\text{s}$  from the previous setting. The software automatically changes the laser delay setting.

OR

Notifies you if laser delay is  $>5 \mu\text{s}$  from the previous setting. Manual laser delay adjustments are required. Refer to [CHAPTER 12, Setting Laser Delay](#).

6. Verifies and calibrates the gain settings. If any of these parameters are outside of the operating limits, the system automatically adjusts these parameters. If the system is unable to adjust these parameters to fall within the operating limits, the system notifies you.

## Preparing the QC Sample

### Required Materials

The following materials are required to complete the QC process:

- CytoFLEX Daily QC Fluorospheres or CytoFLEX Ready to Use Daily QC Fluorospheres
- CytoFLEX Daily IR QC Fluorospheres (for systems configured with an IR laser)
- CytoFLEX Sheath Fluid or another nonionic antimicrobial sheath fluid
- Sample tubes (12 x 75 mm)
- Vortexer

### CytoFLEX Daily QC Fluorospheres Preparation Process

**IMPORTANT** For preparation instructions for the CytoFLEX Ready to Use Daily QC Fluorospheres or the CytoFLEX Daily IR QC Fluorospheres, refer to [CytoFLEX Ready to Use Daily QC Fluorospheres Preparation Process](#) or [CytoFLEX Daily IR QC Fluorospheres Preparation Process](#).

- 1 Take one sample tube and label it as the QC sample tube.
- 2 Add approximately 1 mL of deionized water to the sample tube.
- 3 Use the vortexer or shake vigorously to thoroughly mix the bottle of CytoFLEX Daily QC Fluorospheres.
- 4 Add 3 drops of CytoFLEX Daily QC Fluorospheres to the sample tube.
- 5 Vortex the sample tube to uniformly suspend the fluorospheres.
- 6 Place the sample tube in a dark location at 2-8 °C until ready to load the tube into the instrument for QC.

**NOTE** Tubes containing diluted CytoFLEX Daily QC Fluorospheres should be sealed and stored in a dark location at 2-8 °C for up to 5 days.

## CytoFLEX Ready to Use Daily QC Fluorospheres Preparation Process

**IMPORTANT** For preparation instructions for the CytoFLEX Daily QC Fluorospheres or the CytoFLEX Daily IR QC Fluorospheres, refer to [CytoFLEX Daily QC Fluorospheres Preparation Process](#) or [CytoFLEX Daily IR QC Fluorospheres Preparation Process](#).

- 1 Take one sample tube and label it as the QC sample tube.
- 2 Use the vortexer to thoroughly mix the bottle of CytoFLEX Ready to Use Daily QC Fluorospheres for two or three seconds.
- 3 Add 10 drops of CytoFLEX Ready to Use Daily QC Fluorospheres to the sample tube.
- 4 Vortex the sample tube to uniformly suspend the fluorospheres.
- 5 Place the sample tube in a dark location at 2-8 °C until ready to load the tube into the instrument for QC.

**NOTE** Tubes containing CytoFLEX Ready to Use Daily QC Fluorospheres should be sealed and stored in a dark location at 2-8 °C for up to 5 days.

## CytoFLEX Daily IR QC Fluorospheres Preparation Process

**IMPORTANT** For preparation instructions for the CytoFLEX Daily QC Fluorospheres or the CytoFLEX Ready to Use Daily QC Fluorospheres, refer to [CytoFLEX Daily QC Fluorospheres Preparation Process](#) or [CytoFLEX Ready to Use Daily QC Fluorospheres Preparation Process](#).

- 1 Take one sample tube and label it as the QC/IR sample tube.
- 2 Mix the CytoFLEX Daily IR QC Fluorospheres by inversion.
- 3 Add 10 drops of CytoFLEX Daily IR QC Fluorospheres to the sample tube.
- 4 Place the sample tube in a dark location at 2-8 °C until ready to load the tube into the instrument for QC.

**NOTE** Tubes containing diluted CytoFLEX Daily IR QC Fluorospheres should immediately be sealed and stored in a dark location at 2-8 °C for up to 5 days.

## Preparing the QC Sample [With Plate Loader]

### Required Materials

The following materials are required to complete the QC process:

- CytoFLEX Daily QC Fluorospheres or CytoFLEX Ready to Use Daily QC Fluorospheres
- CytoFLEX Daily IR QC Fluorospheres (for systems configured with an IR laser)
- CytoFLEX Sheath Fluid or another nonionic sheath fluid
- Standard 96-well plate
  - 96-well flat-bottom
  - 96-well V-bottom
  - 96-well U-bottom
- 96-well deep well plate
  - 96-well V-bottom
  - 96-well U-bottom
- Vortexer

### CytoFLEX Daily QC Fluorospheres Preparation Process

**IMPORTANT** For preparation instructions for the CytoFLEX Ready to Use Daily QC Fluorospheres or the CytoFLEX Daily IR QC Fluorospheres, refer to [CytoFLEX Ready to Use Daily QC Fluorospheres Preparation Process](#) or [CytoFLEX Daily IR QC Fluorospheres Preparation Process](#).

---

**1** Take one 96-well plate and record the QC sample well position.

---

**2** Use the vortexer or shake vigorously to thoroughly mix the bottle of CytoFLEX Daily QC Fluorospheres.

---

**IMPORTANT** Do not overfill the sample well.

---

**3** Add one drop of CytoFLEX Daily QC Fluorospheres to the sample well.

---

**4** Add 200  $\mu$ L of deionized water to the sample well.

---

**5** Place the well plate in a dark location at 2-8 °C until ready to load the well plate into the instrument for QC.

**NOTE** Well plates containing diluted CytoFLEX Daily QC Fluorospheres should be stored sealed in a dark location at 2-8 °C for up to 5 days.

## CytoFLEX Ready to Use Daily QC Fluorospheres Preparation Process

**IMPORTANT** For preparation instructions for the CytoFLEX Daily QC Fluorospheres or the CytoFLEX Daily IR QC Fluorospheres, refer to [CytoFLEX Daily QC Fluorospheres Preparation Process](#) or [CytoFLEX Daily IR QC Fluorospheres Preparation Process](#).

- 1 Take one 96-well plate and record the QC sample well position.
- 2 Use the vortexer to thoroughly mix the bottle of CytoFLEX Ready to Use Daily QC Fluorospheres for two or three seconds.
- 3 Add 3-4 drops of CytoFLEX Ready to Use Daily QC Fluorospheres to sample well.
- 4 Place the well plate in a dark location at 2-8 °C until ready to load the well plate into the instrument for QC.

**NOTE** Well plates containing CytoFLEX Ready to Use Daily QC Fluorospheres should be stored sealed in a dark location at 2-8 °C for up to 5 days.

## CytoFLEX Daily IR QC Fluorospheres Preparation Process

**IMPORTANT** For preparation instructions for the CytoFLEX Daily QC Fluorospheres or the CytoFLEX Ready to Use Daily QC Fluorospheres, refer to [CytoFLEX Daily QC Fluorospheres Preparation Process](#) or [CytoFLEX Ready to Use Daily QC Fluorospheres Preparation Process](#).

- 1 Take one 96-well plate and label one well as the QC/IR sample well.
- 2 Mix the CytoFLEX Daily IR QC Fluorospheres by inversion.

**IMPORTANT** Do not overfill the sample well.

- 3 Add 3-4 drops of CytoFLEX Daily IR QC Fluorospheres to the sample well.
- 4 Place the well plate in a dark location at 2-8 °C until ready to load the well plate into the instrument for QC.

**NOTE** Well plates containing CytoFLEX Daily IR QC Fluorospheres should immediately be sealed and stored in a dark location at 2-8 °C for up to 5 days.

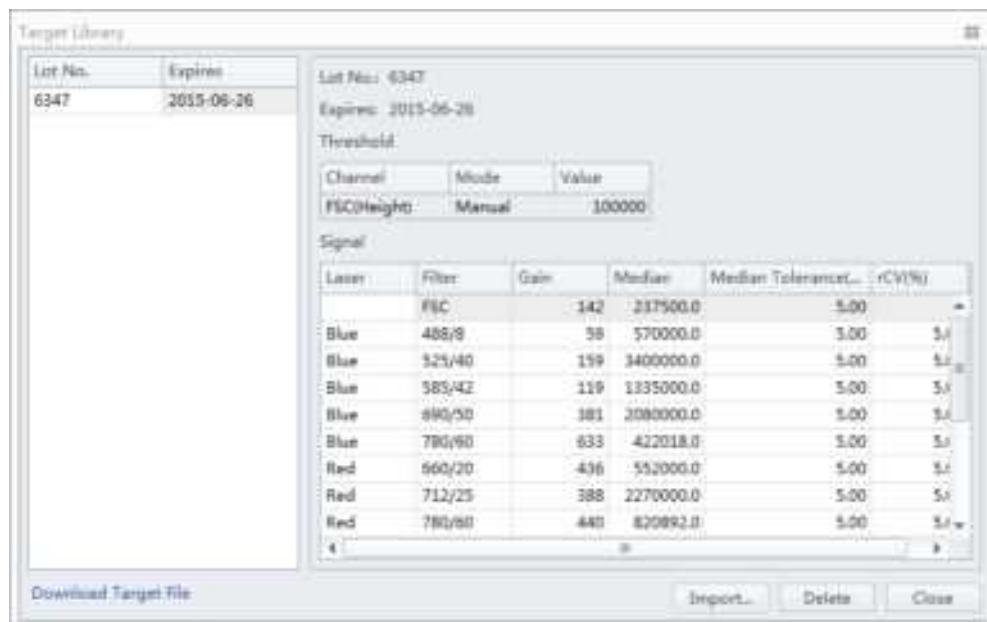
## Importing Lot-Specific Target Values

Import lot-specific target values for each new lot of CytoFLEX QC Fluorospheres, CytoFLEX Ready to Use Daily QC Fluorospheres, or CytoFLEX Daily IR QC Fluorospheres.

### CAUTION

**Risk of erroneous QC results. Different target value information correspond to different lot numbers. Selecting the wrong lot number will lead to erroneous QC results.**

- 1 Open the CytExpert QC screen.
- 2 Select **Target Library** from the Settings menu. The Target Library window appears.



**IMPORTANT** The Beckman Coulter website may prompt you to select your Region and Country prior to the Beckman Coulter Technical Documents and Software page.

- 3 Select **Download Target File**. The Beckman Coulter Technical Documents and Software Downloads page appears.



**NOTE** If your CytoFLEX Workstation does not have access to the internet, navigate to <https://www.beckmancoulter.com/wsportal/page/softwareDownloadSearch> using a computer with access to the internet and save the file to a USB drive. If the website is not accessible, [contact us](#).

- 4 If necessary, register and log in to the Beckman Coulter website.

- 5 In the Search By Product section of the screen, select the following:
  - a. Select **Research & Discovery** from the Market Segment drop-down menu.
  - b. Select **Flow Cytometry** from the Product Line drop-down menu.
  - c. Select **Instruments** from the Product Platform drop-down menu.
  - d. Select **CytoFLEX** from the Product drop-down menu.
  - e. Select **CytoFLEX QC Fluorospheres Target** or **CytoFLEX Ready to Use QC Fluorospheres Target**, or **CytoFLEX IR QC Fluorospheres Target** from the Software Name drop-down menu.
  - f. Select **All** from the Lot Number drop-down menu.
  - g. Select **English** from the Language drop-down menu.

[CytoFLEX QC Fluorospheres Target]



[CytoFLEX IR QC Fluorospheres Target]



[CytoFLEX Ready to Use Daily QC Fluorospheres Target]



6 Select **Search**.

7 The search results appear below the Search By Lot Number tab.

[CytoFLEX QC Fluorospheres Target]

Software Download Search Results

Software Name*	Product	Lot No.	Version	Software ID	Release Date	License
<a href="#">CytoFLEX QC Fluorospheres Target</a>	CytoFLEX	12345	40000	40000		Open

[CytoFLEX IR QC Fluorospheres Target]

Software Download Search Results

Software Name*	Product	Lot No.	Version	Software ID	Release Date	License
<a href="#">CytoFLEX IR QC Fluorospheres Target</a>	CytoFLEX	12345	40000	40000		Open

[CytoFLEX Ready to Use Daily QC Fluorospheres Target]

Software Download Search Results

Software Name*	Product	Lot No.	Version	Software ID	Release Date	License
<a href="#">CytoFLEX Ready to Use Daily QC Fluorospheres Target</a>	CytoFLEX	12345	40000	40000	01/10/2010	Open

- 8 Select **CytoFLEX QC Fluorospheres Target Values** under the Software Name column. The CytoFLEX QC Fluorospheres Target Values page appears.



- 9 Select **Download** under the correct lot number from the CytoFLEX QC Fluorospheres Target Values page.

- 10 If the File Download pop up window appears, select **Save** and browse to the desired file path.



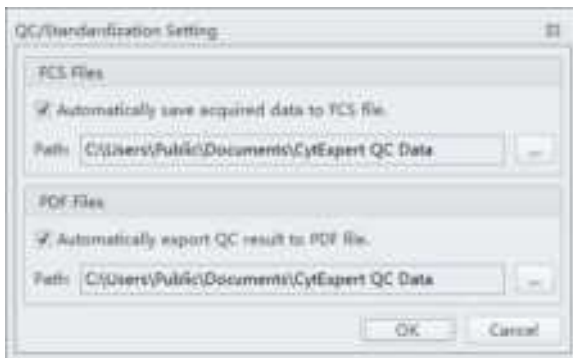
- 11 Select **Import** from the Target Library window in the CytExpert software.


- 12 Navigate to the file saved in Step 10 and select **Open**.

- 
- 13 Select **Close** to exit the Target Library window.
- 

## Collecting QC Data

QC data and reports are saved by default. Select **QC/Standardization Setting** in the Settings menu to change the default save settings or modify the file path these files are saved to.



- 
- 1 Double-click  to start the CytExpert software.
- Ensure that the **Connected** icon on the Status Bar near the bottom-left side of the display is green.



- If the icon is not green, ensure that the Cytometer USB is securely connected to the Workstation and restart the Workstation.

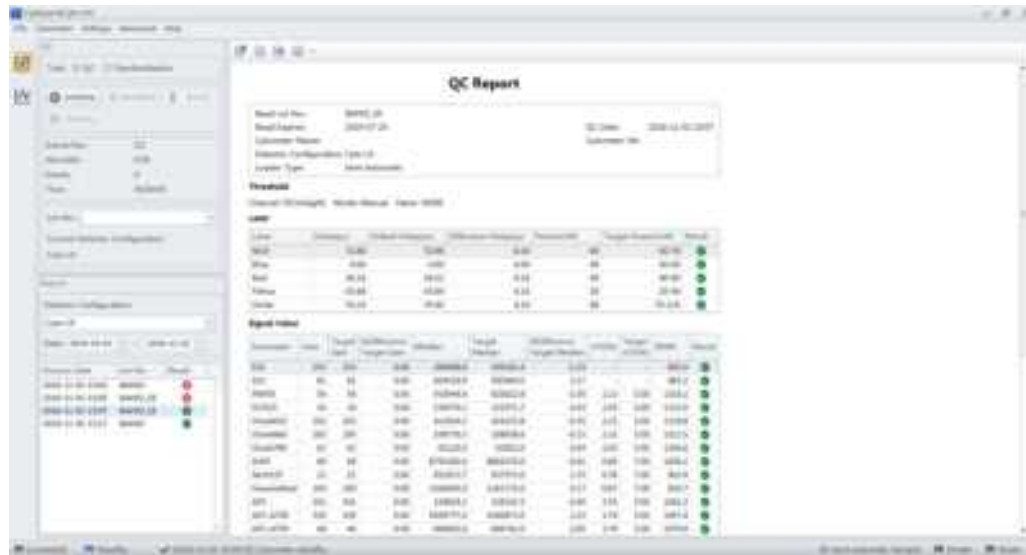
- 
- 2 Verify the detector configuration. Refer to [CHAPTER 6, Verifying, Selecting, Editing, and Creating Detector Configuration](#).

**NOTE** Ensure that the instrument configuration is properly configured for the QC experiment. The QC experiment may not be completed or may end in erroneous results if incorrect settings are chosen. Beckman Coulter recommends using the factory configuration and ensuring that the proper optical filters are in place.

- 
- 3 Verify the laser settings. Refer to [CHAPTER 6, Laser Settings](#).

- 4 Select **Start QC/Standardization** in the QC/Standardization menu to access the QC experiment.

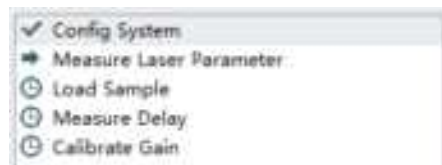
[CytoFLEX LX Shown]



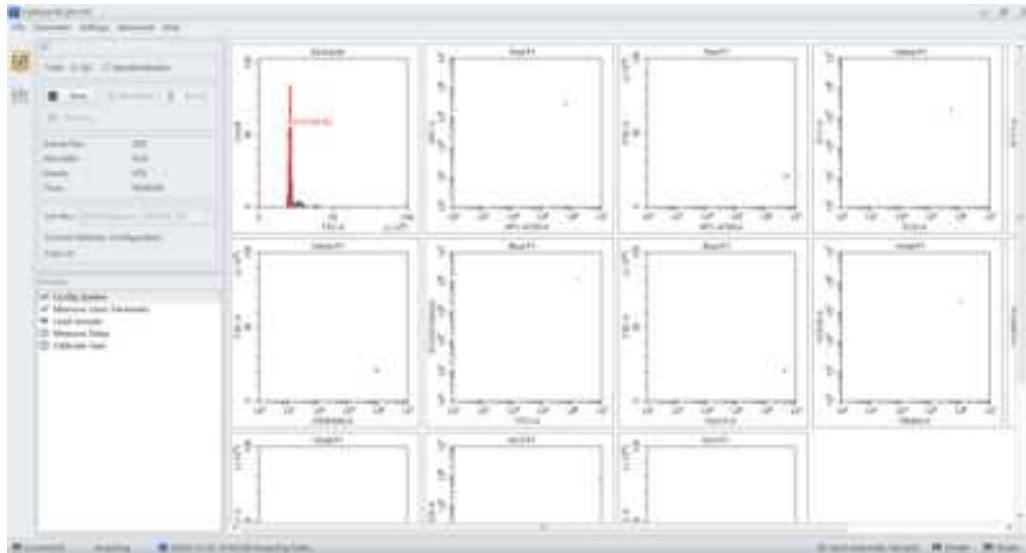
Ensure that the QC bead lot number is selectable in the Lot No. drop down menu. If the lot number is not selectable, refer to [Importing Lot-Specific Target Values](#), then select the proper lot number.

- 5 Select **Initialize**.
- 6 Insert the prepared QC sample tube (see [CytoFLEX Ready to Use Daily QC Fluorospheres Preparation Process](#), or [CytoFLEX Daily QC Fluorospheres Preparation Process](#)) into the tube holder.
- 7 Select **Start** to load the sample and begin to run the QC procedure.

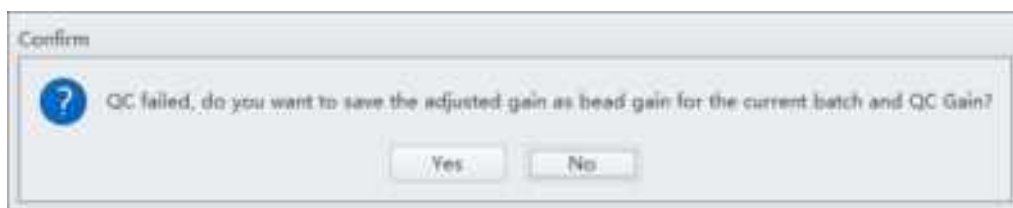
Completed processes appear on the left. Plots appear on the right. The QC experiment sequentially detects the system configuration, laser power, laser delay, signal strength, and coefficient of variation.



During QC, the software automatically seeks the CytoFLEX QC Fluorospheres and computes the results. The software returns to the QC Report screen after the QC run is complete.



- 8 If the sampling rate is too low, the Cytometer stops the QC run and displays a prompt alerting you that the QC run failed to reach the required event flow rate. This is not considered a QC failure. If this situation occurs, increase the sample concentration by adding one drop of CytoFLEX QC Fluorospheres to the sample tube and then perform the QC.
- 9 If the lot number of CytoFLEX QC Fluorospheres is new and QC fails, the following software message appears. Select **Yes**.



**NOTE** Target gain values must be established for each new lot number of CytoFLEX QC Fluorospheres. QC could fail up to 3 times upon running each new lot number for the first time until target gain values are established.

If the lot number of CytoFLEX QC Fluorospheres is NOT new and QC fails, refer to Step 3 of [CHAPTER 5, Confirming Results](#), or [CHAPTER 10, Troubleshooting](#).


If QC passes, proceed to Step 16.

- 10 Run Daily Clean to remove any residual fluorosphere particles if using CytoFLEX Daily QC Fluorospheres. Refer to [CHAPTER 11, Daily Clean](#).

## Collecting QC Data [With Plate Loader]

QC data and reports are saved by default. Select **QC/Standardization Setting** in the Settings menu to change the default save settings or modify the file path these files are saved to.



- 1 Double-click  to start the CytExpert software.
  - a. Ensure that the **Connected** icon on the Status Bar near the bottom-left side of the display is green.

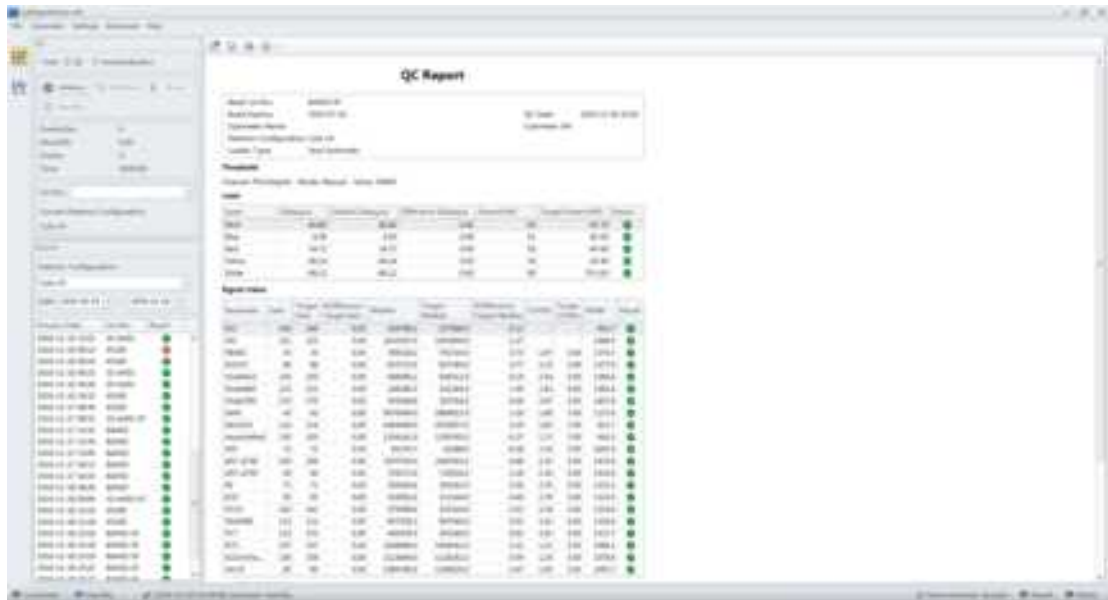


- b. If the icon is not green, ensure that the Cytometer USB is securely connected to the Workstation and restart the Workstation.
- 2 Verify the detector configuration. Refer to [CHAPTER 6, Verifying, Selecting, Editing, and Creating Detector Configuration](#).

**NOTE** Ensure that the instrument configuration is properly configured for the QC experiment. The QC experiment may not be completed or may end in erroneous QC results if incorrect settings are chosen. Beckman Coulter recommends using the factory configuration and ensuring that the proper optical filters are in place.

- 3 Verify the laser settings. Refer to [CHAPTER 6, Laser Settings](#).
- 4 Select **Start QC/Standardization** in the QC/Standardization menu to access the QC experiment.

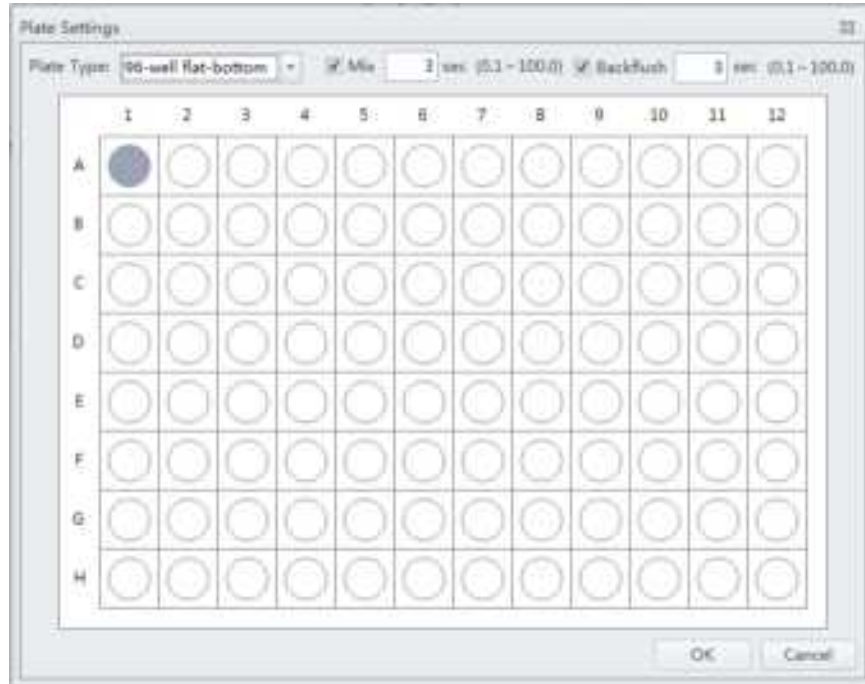
[CytoFLEX LX Shown]



Ensure that the QC bead lot number is selectable in the Lot No. drop down menu. If the lot number is not selectable, refer to [CHAPTER 5, Importing Lot-Specific Target Values](#), then select the proper lot number.

- 
- 5 Select **Initialize**.
- 
- 6 Select **Eject**.
- 
- 7 Insert the prepared QC well plate (see [CytoFLEX Daily QC Fluorospheres Preparation Process](#) or [CytoFLEX Ready to Use Daily QC Fluorospheres Preparation Process](#) or [CytoFLEX Daily IR QC Fluorospheres Preparation Process](#)) into the plate holder.

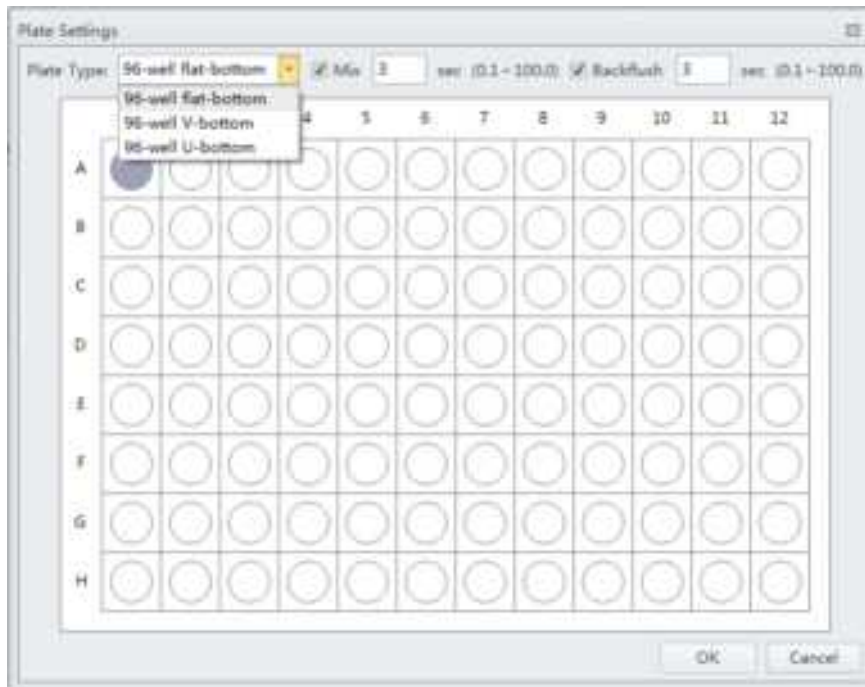
- 8 Select . The Plate Settings window appears.



**IMPORTANT** Ensure the well position on the plate matches the well position selected in the software.

- 9 Select the appropriate QC well.

- 10 Select the desired plate type from the Plate Type dropdown menu.



**NOTE** The available plate types included in the dropdown menu depend on the settings selected in the Plate Library. Refer to [CHAPTER 2, Plate Type Library](#).

- 11 Select the Mix and Backflush settings in the top of the Plate Settings window.

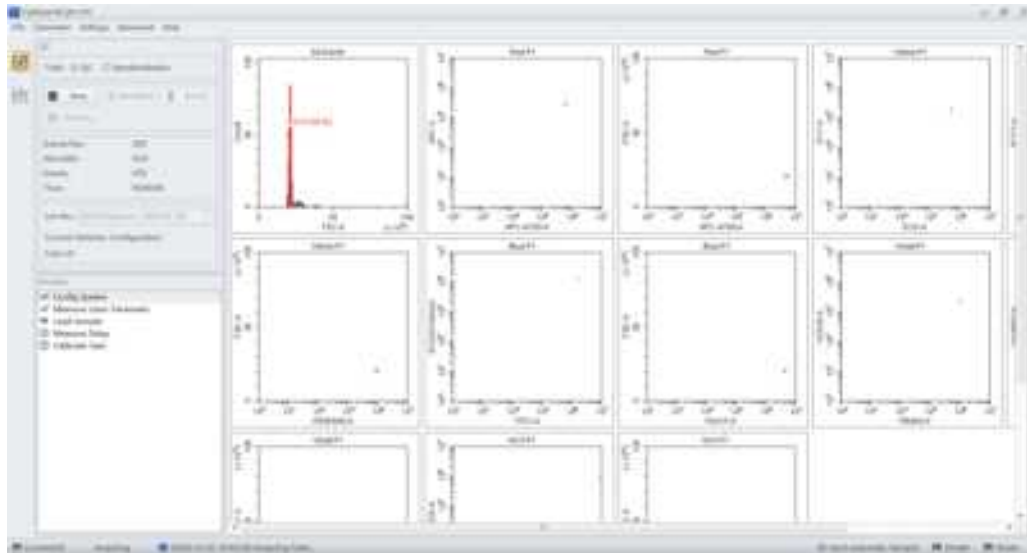
- 12 Select **OK**.

- 13 Select **start** to load the sample and begin to run the QC procedure. The message *Please confirm that the correct plate is placed properly and press OK* appears. Select **OK**.

Completed processes appear on the left. Plots appear on the right. The QC experiment sequentially detects configuration, laser power, laser delay, signal strength, and coefficient of variation.



During QC, the software automatically seeks the CytoFLEX QC Fluorospheres and computes the results. The software returns to the QC screen after the QC run is complete.

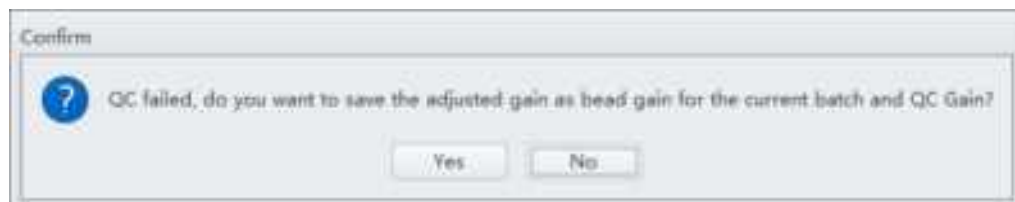


- 14** If the sampling rate is too low, the Cytometer stops the QC run and displays a prompt that the QC run fails to reach the required event flow rate. This is not considered a QC failure. If this situation occurs, increase the sample concentration by adding one drop of CytoFLEX Daily QC Fluorospheres to the sample tube or prepare a new tube of CytoFLEX Ready to Use Daily QC Fluorospheres and then perform the experiment.

**NOTE** Mix the fluorospheres dropper bottle thoroughly before dispensing it into a sample tube.

**NOTE** If the sample flow rate is not correct, calibrate the sample flow rate before running the QC. For instructions on calibrating the sample flow rate, refer to [CHAPTER 12, Calibrating the Sample Flow Rate](#) or [CHAPTER 12, Calibrating the Sample Flow Rate \[With Plate Loader\]](#).

- 15** If the lot number of CytoFLEX QC Fluorospheres is new and QC fails, the following software message appears. Select **Yes**.



**NOTE** Target gain values must be established for each new lot number of CytoFLEX QC Fluorospheres. QC could fail up to 3 times upon running each new lot number for the first time until target gain values are established.

If the lot number of CytoFLEX QC Fluorospheres is NOT new and QC fails, refer to Step 3 of [CHAPTER 5, Confirming Results](#), or [CHAPTER 10, Troubleshooting](#).

If QC passes, proceed to Step 16.

- 16 Run Daily Clean to remove any residual fluorosphere particles. Refer to [CHAPTER 11, Daily Clean \[With Plate Loader\]](#).

## Confirming Results

Select **Start QC/Standardization** in the QC/Standardization menu to return to the QC Setting screen at any time to review completed experiment results.

- 1 Select the desired default configuration and date range from the drop-down menus located on the left side of the QC screen to sort by the configuration used during the specified date range.



**NOTE** At least one date range must be specified.

- 2 Select a QC run from the QC Process list on the left and a QC report appears on the right.

Process Date	Lot No.	Result
2016-11-02 15:02	BAH02	✘
2016-11-02 15:05	BAH02_SE	✘
2016-11-02 15:07	BAH02_SE	✔
2016-11-02 15:17	BAH02	✔
2016-11-02 15:41	BAH02	✔



**NOTE** The results column indicates a passing QC result with a ✔ and a failed QC result with ✘.

QC results must meet the following criteria to pass:

- The gain differences must be  $\leq 20\%$  from the target gain.
- The median fluorescence intensity (MFI) differences must be  $\leq 5\%$  from the target MFI.
- The rCV must be within the range.

**NOTE** The CytoFLEX Daily QC Fluorospheres / CytoFLEX Ready to Use Daily QC Fluorospheres / Daily IR QC Fluorospheres (808 Laser) rCV must meet the following criteria to pass:

- The rCV for channels of the 405 nm, 488 nm, 561 nm, 638 nm lasers must be  $\leq 5\%$ .
- The rCV for channels of the 355 nm, 375 nm, 808 nm lasers must be  $\leq 7\%$ .

The report area on the right displays detailed experiment results, including laser power, delay, testing conditions, and signal results. The same  and  symbols are used to indicate each result. For items that fail, values falling outside the prescribed range are displayed in red font. In the Comment area, an explanation appears for each failed item.



### QC Report

Bead Lot No:	A333	QC Date:	2015-01-20 10:23
Bead Expires:	2015-09-30	Cytometer SN:	AR38012
Cytometer Name:	CytoFLEX	Detector Configuration:	Default-Configuration
Detector Configuration:	Default-Configuration	Loader Type:	Semi Automatic

#### Threshold

Channel: FSC(Height) Mode: Manual Value: 50000

#### Laser

Laser	Delay(µs)	Default Delay(µs)	Difference Delay(µs)	Power(mW)	Target Power(mW)	Result
Blue laser	0.00	0.00	0.00	53	40-60	
Red laser	-37.12	-38.38	2.24	53	40-60	

#### Signal Value

Parameter	Gain	Target Gain	%Difference Target Gain	Median	Target Median	%Difference Target Median	rCV(%)	Target rCV(%)	Width	Result
FSC	20	107	-81.31	242486.0	242482.7	0.00	-	-	1117.1	
SSC	14	96	-85.42	608217.2	601799.3	1.07	-	-	1187.8	
FITC	19	406	-95.34	3279233.0	3113982.0	-1.05	2.27	5.00	1188.6	
PE	26	71	-63.38	1117258.0	1145402.0	-2.48	2.22	5.00	1134.0	
APC	3000	472	535.58	29186.1	481724.0	-93.93	11.11	5.00	1700.8	
APC-A750	3000	493	506.06	20604.3	689351.1	-97.01	17.48	5.00	1433.5	

#### Specifications

Delay:  $-5.00\mu s \leq \text{Difference Delay} \leq 5.00\mu s$ .  
 Gain:  $-20.00\% \leq \% \text{Difference Target Gain} \leq 20.00\%$ .  
 Median:  $-5.00\% \leq \% \text{Difference Target Median} \leq 5.00\%$ .  
 rCV:  $rCV(\%) \leq \text{Target } rCV(\%)$ .

#### Result

**QC Failed.**

#### Comment

The difference between FSC gain and target is more than 20%.  
 The difference between SSC gain and target is more than 20%.  
 The difference between FITC gain and target is more than 20%.  
 The difference between PE gain and target is more than 20%.  
 APC gain calibration was failed, median value is out of the target value range.  
 APC-A750 gain calibration was failed, median value is out of the target value range.

Laser-filter combinations that are not part of a default configuration may not have a target value defined in the QC target file and therefore will not generate a result during QC. Use the Target Library in the QC screen of CytExpert Software to view the list of laser-filter combinations that have target values assigned within a target file and therefore will return a result for QC.

### QC Report

Bead Lot No.:	QC beads Lot A104	QC Date:	2018-07-05 11:07
Bead Expires:	2020-07-04	Cytometer SN:	AW42285
Cytometer Name:	CytoFLEX		
Detector Configuration:	Default-Configuration2		
Loader Type:	Carousel Mode		

#### Threshold

Channel: FSC(Height) Mode: Manual Value: 50000

#### Laser

Laser	Delay(µs)	Default Delay(µs)	Difference Delay(µs)	Power(mW)	Target Power(mW)	Result
Blue	0.00	0.00	0.00	46	40-60	✓
Red	-40.16	-40.48	0.32	53	40-60	✓
Violet	38.72	38.88	-0.16	79	70-120	✓

#### Signal Value

Parameter	Gain	Target Gain	%Difference Target Gain	Median	Target Median	%Difference Target Median	rCV(%)	Target rCV(%)	Width	Result
FSC	85	85	0.00	207878.7	211000.0	-1.48	-	-	1133.1	✓
SSC	74	74	0.00	601946.9	590000.0	2.02	-	-	1271.7	✓
FITC	86	86	0.00	1630195.0	1594000.0	2.27	3.32	5.00	1251.5	✓
PE	92	92	0.00	1843533.0	1885000.0	-2.20	3.38	5.00	1248.1	✓
ECD	110	106	3.77	1157910.0	1163000.0	-0.44	3.54	5.00	1253.8	✓
PC5.5	236	236	0.00	4499044.0	4539000.0	-0.88	3.09	5.00	1260.1	✓
PC7	308	308	0.00	2218625.0	2240000.0	-0.95	3.17	5.00	1263.8	✓
APC	389	389	0.00	322403.3	335000.0	-3.76	2.24	5.00	1370.9	✓
APC-A700	408	408	0.00	5445790.0	5516000.0	-1.27	1.98	5.00	1374.1	✓
PB450	76	76	0.00	895413.4	895000.0	0.05	1.11	5.00	1292.7	✓
KO525	45	45	0.00	227806.7	230000.0	-0.95	1.08	5.00	1291.4	✓
Violet610	262	262	0.00	399744.6	397000.0	0.69	1.23	5.00	1296.0	✓
Violet660	290	290	0.00	104906.3	104000.0	0.87	1.46	5.00	1298.3	✓
Violet780	253	253	0.00	428127.4	425000.0	0.74	1.22	5.00	1300.7	✓

#### Specifications

Delay:  $-5.00\mu s \leq \text{Difference Delay} \leq 5.00\mu s$   
 Gain:  $-20.00\% \leq \% \text{Difference Target Gain} \leq 20.00\%$   
 Median:  $-5.00\% \leq \% \text{Difference Target Median} \leq 5.00\%$   
 rCV:  $rCV(\%) \leq \text{Target } rCV(\%)$

#### Result

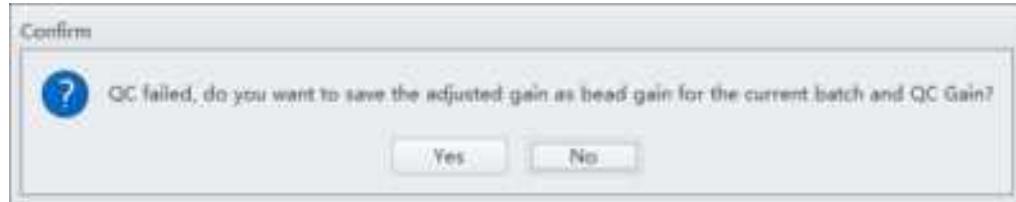
QC Passed.

#### Comment

No target value for CUSTOM(Red,769/45).



**3** If QC fails, follow the procedure below:

**NOTE** Select **No** if the Confirm window appears.



- a. Verify whether the beads used were within their shelf life and stored in accordance with the appropriate instruction manual.
- b. Verify whether the allocated sample tube was prepared as required and correctly positioned.
- c. Verify whether the detector configuration selected for QC matches with the current detector configuration. Refer to [CHAPTER 6, Verifying, Selecting, Editing, and Creating Detector Configuration](#).
- d. Run [CHAPTER 12, Priming the Flow Cell](#), and retest.
- e. Run [CHAPTER 11, Daily Clean](#), and retest.
- f. Run [CHAPTER 11, Deep Clean Procedure](#), and retest.
- g. Repeat Steps d-e.


**NOTE** If QC fails two times in a row on the same day after repeating Steps a-g, [contact us](#).

**4** If necessary, you can select  (for CSV format) or  (for PDF format) in the top left corner of the report area to export the QC results.


**5** Select **Close QC/Standardization** in the File menu to exit the QC screen.

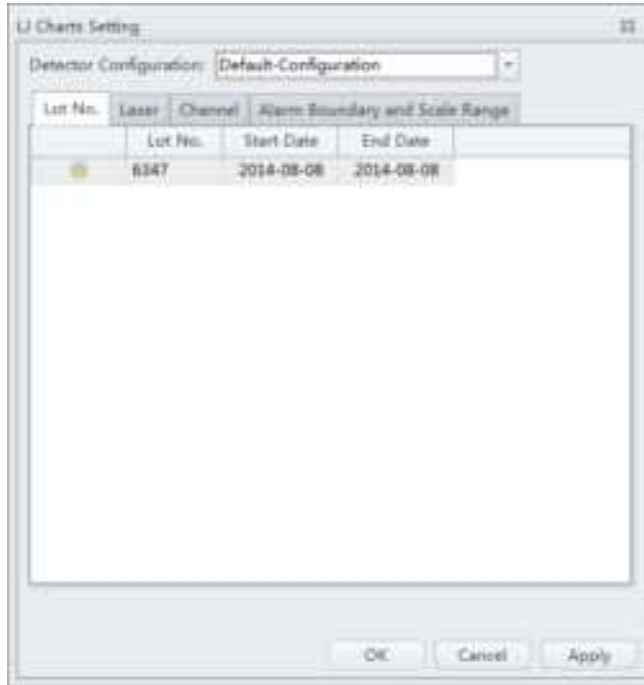
### Creating Levey-Jennings Charts

**1** Select **Start QC/Standardization** in the QC/Standardization menu to open the QC screen.

**2** Select LJ chart  on the left side of the screen.

**IMPORTANT** When there are multiple lots, select which lot to create the LJ charts from.

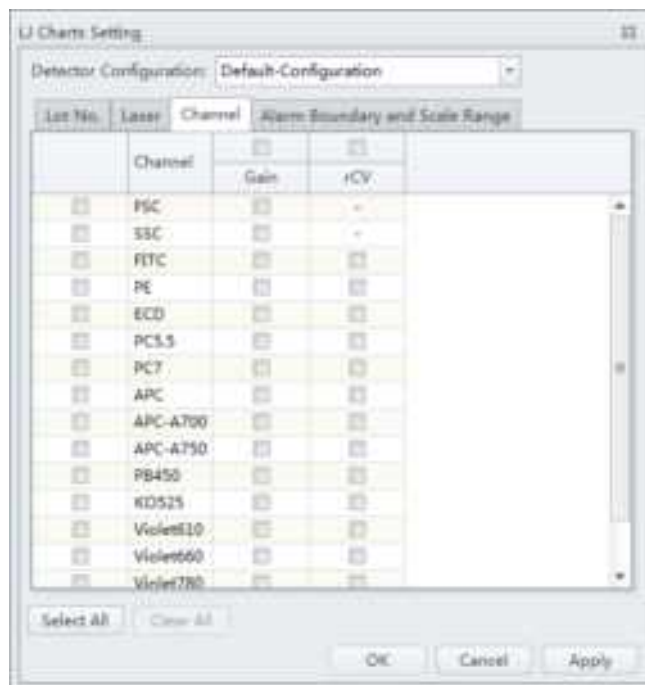
- 3 Select LJ Chart Settings  on the top of the LJ Chart screen. The LJ Chart Settings screen appears.



- 4 Select the **Laser** tab, and select the power and/or delay checkboxes for each laser as needed.



- 5 Select the **Channels** tab, and select each channel checkbox as needed.



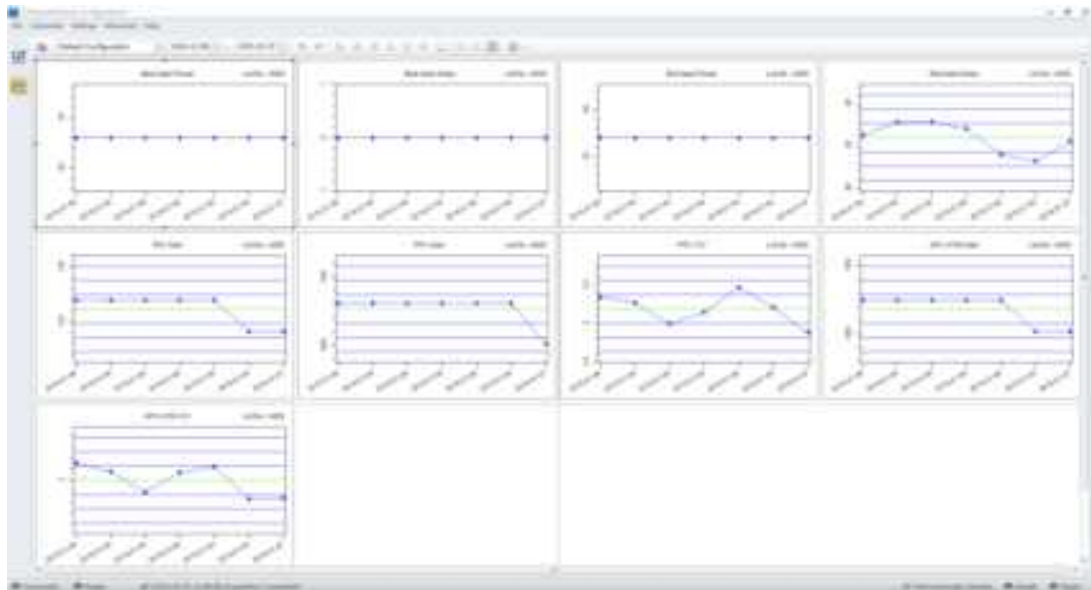
- 
- 6 Select **Apply**.

---

  - 7 Select **OK**.

---

  - 8 Select the Levey-Jennings plot and select the start and end date from the drop down boxes at the top of the LJ Chart screen to specify the desired date range.



**NOTE** Select the desired configuration and date range from the drop-down menus located at the top of the LJ Chart screen to sort by the configuration used during the specified date range.

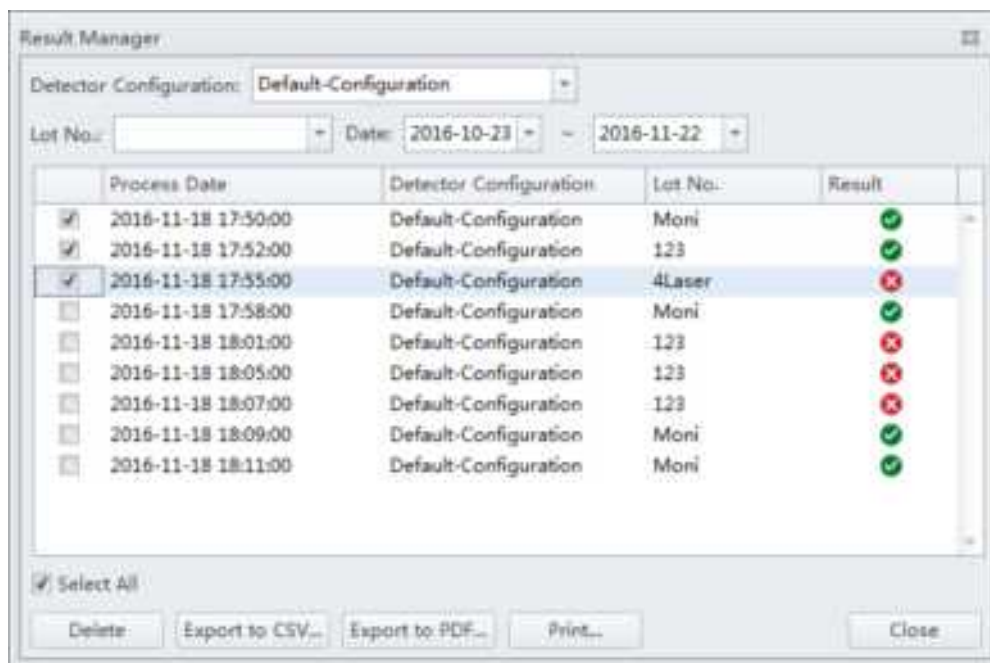


- 
- 9 Select **Close QC/Standardization** in the File menu to exit the QC screen.
- 

## QC Result Manager

The QC Result Management window can be used to search, delete, print, and export QC results.

To access the QC Result Manager, right-click the desired QC result and select **Result Manager** in the QC screen. The QC Result Manager window appears.



## Standardization

Ensure that the standardization sample has been run at optimized experiment settings to determine the standardization sample threshold setting as well as median values for all relevant channels.

### Preparing the Standardization Sample

Use Beckman Coulter CytoFLEX Daily QC fluorospheres or CytoFLEX Ready to Use Daily QC Fluorospheres or any other reference material that is relevant for your application.

## Required Materials

The following materials are required to complete the QC process:


- CytoFLEX Daily QC Fluorospheres or CytoFLEX Ready to Use Daily QC Fluorospheres, or other material applicable for your application
- CytoFLEX Daily IR QC Fluorospheres (for systems configured with an IR laser)
- CytoFLEX Sheath Fluid
- Sample tubes (12 x 75 mm).
- Vortexer

## Preparation Process

For procedures, refer to [CytoFLEX Daily QC Fluorospheres Preparation Process](#) and/or [CytoFLEX Ready to Use Daily QC Fluorospheres Preparation Process](#) and/or [CytoFLEX Daily IR QC Fluorospheres Preparation Process](#).

## Generating Target Median Values

---

- 1 Double-click  to start the CytExpert software.
  - a. Ensure that the **Connected** icon on the Status Bar near the bottom-left side of the display is green.




- b. If the icon is not green, ensure that the Cytometer USB is securely connected to the Workstation and restart the Workstation.
- 
- 2 Select **Open Experiment** to open an experiment with the desired acquisition settings to standardize.

**NOTE** Ensure the Gain and Threshold settings are optimal. Refer to [CHAPTER 6, Adjusting the Gain](#) and [CHAPTER 6, Adjusting the Threshold](#).
  - 3 Right-click the tube and select **Duplicate without Data** to create a tube with the same acquisition settings.

- 
- 4 Change the tube name. Refer to [CHAPTER 6, Changing the Tube Name](#).

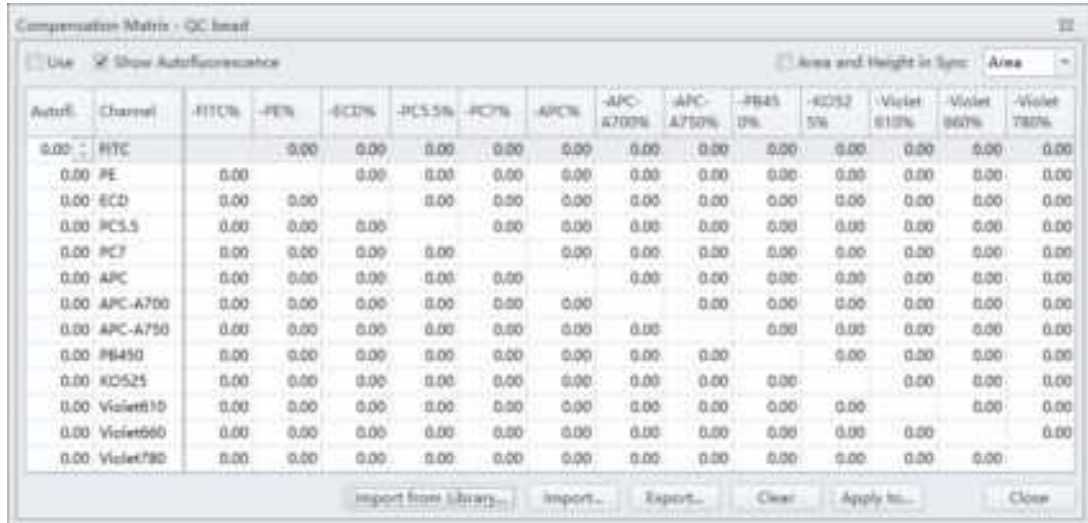


- 
- 5 Select **Save As** from the File menu to save the experiment.

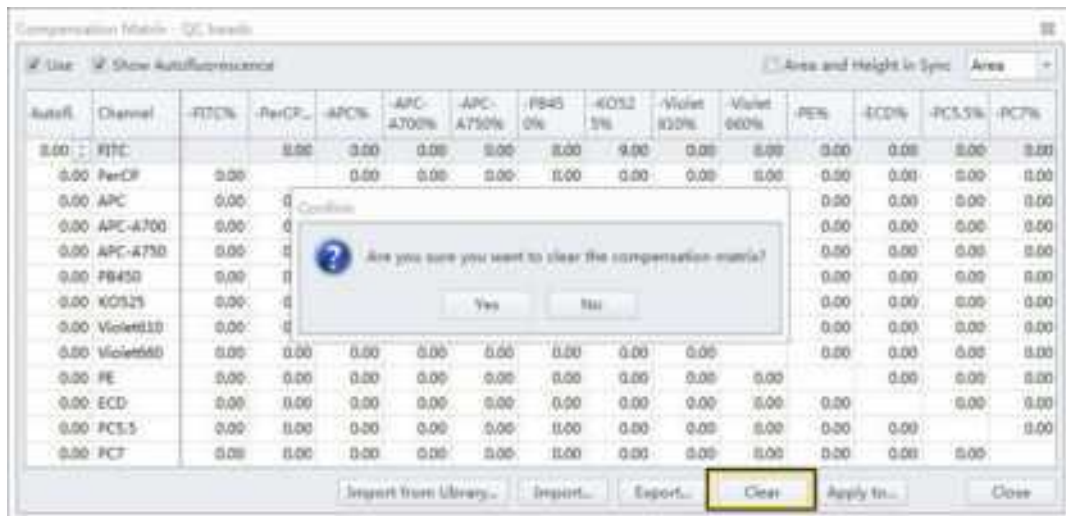
- 
- 6 Select  to delete all the remaining tubes.



7 Select . The Compensation Matrix window appears.



8 Select **Clear** to clear the compensation matrix. The message *Are you sure you want to clear the compensation matrix?* appears. Select **Yes**.



9 Load the sample tube.

**NOTE** The sample tube holder accommodates 1.5 mL, 2.0 mL, and 12 x 75 mm sample tubes.

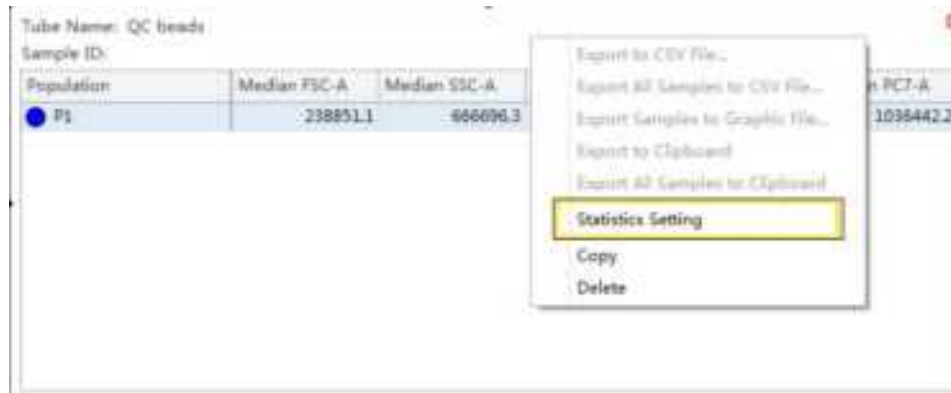
10 Select **Run**.

11 View the plots and establish the gates. Refer to [CHAPTER 6, Creating Plots and Gates](#).

**NOTE** Use the FSC channel as the trigger channel and select **Automatic** threshold.

**NOTE** The threshold may need to be adjusted to visualize the QC beads populations. If so, record this value for future reference.

12 Right-click the table and select **Statistics Settings**. The Statistics Setting window appears.



**13** Select the **Population** tab and select the relevant population for the tube.



- 14 Select the **Statistics** tab then select the Median Fluorescence value for all parameters used.

Statistics Setting

Header Statistics Population

Parent Population  Events  % Total  % Parent  Events/(μL)V

Events/(μL)B

Beads Population:  Select...

Beads Count:  Sample Volume:  μL

Parameter	<input type="checkbox"/>	<input type="checkbox"/>	<input type="checkbox"/>	<input type="checkbox"/>	<input type="checkbox"/>	<input type="checkbox"/>
	Mean	Geometric Mean	Median	rCV	rSD	CV
<input checked="" type="checkbox"/> FSC-A	<input type="checkbox"/>	<input type="checkbox"/>	<input checked="" type="checkbox"/>	<input type="checkbox"/>	<input type="checkbox"/>	<input type="checkbox"/>
<input checked="" type="checkbox"/> SSC-A	<input type="checkbox"/>	<input type="checkbox"/>	<input checked="" type="checkbox"/>	<input type="checkbox"/>	<input type="checkbox"/>	<input type="checkbox"/>
<input checked="" type="checkbox"/> FITC-A	<input type="checkbox"/>	<input type="checkbox"/>	<input checked="" type="checkbox"/>	<input type="checkbox"/>	<input type="checkbox"/>	<input type="checkbox"/>
<input checked="" type="checkbox"/> mCherry-A	<input type="checkbox"/>	<input type="checkbox"/>	<input type="checkbox"/>	<input type="checkbox"/>	<input type="checkbox"/>	<input type="checkbox"/>
<input checked="" type="checkbox"/> PerCP-A	<input type="checkbox"/>	<input type="checkbox"/>	<input type="checkbox"/>	<input type="checkbox"/>	<input type="checkbox"/>	<input type="checkbox"/>
<input checked="" type="checkbox"/> APC-A	<input type="checkbox"/>	<input type="checkbox"/>	<input type="checkbox"/>	<input type="checkbox"/>	<input type="checkbox"/>	<input type="checkbox"/>
<input checked="" type="checkbox"/> APC-A700-L	<input type="checkbox"/>	<input type="checkbox"/>	<input type="checkbox"/>	<input type="checkbox"/>	<input type="checkbox"/>	<input type="checkbox"/>
<input checked="" type="checkbox"/> APC-A750-L	<input type="checkbox"/>	<input type="checkbox"/>	<input type="checkbox"/>	<input type="checkbox"/>	<input type="checkbox"/>	<input type="checkbox"/>
<input checked="" type="checkbox"/> PE-A	<input type="checkbox"/>	<input type="checkbox"/>	<input type="checkbox"/>	<input type="checkbox"/>	<input type="checkbox"/>	<input type="checkbox"/>
<input checked="" type="checkbox"/> ECD-A	<input type="checkbox"/>	<input type="checkbox"/>	<input type="checkbox"/>	<input type="checkbox"/>	<input type="checkbox"/>	<input type="checkbox"/>

Select All Clear All  Area  Height  Area + Height

Preview

Events	% Total	% Parent	Median F...	Median S...	Median FL...

Apply to:  Current Tube  All Tubes  Set As Default OK Cancel

Tube Name: QC beads

Sample ID:

Population	Median FSC-A	Median SSC-A	Median FITC-A	Median PE-A	Median PC7-A
<input checked="" type="radio"/> QC beads	237489.3	662887.4	1009958.8	884541.4	1014320.0

**NOTE** The median values are the target settings that will be used for standardization.

- 15 Right-click the statistics table and select **Export tube to CSV file**.  
If Excel is not available, manually record all the median values or take a screen shot.

## 16 Save the experiment.

**NOTE** Rerun the experiment if:

- You change the standardization fluorosphere used.
- The Lot number for the standardization fluorosphere is changed.

## Adding a New Standardization Item

- 1 Select **Start QC/Standardization** in the QC/Standardization menu to access the Standardization screen.

**Standardization Report**

Task Name: Standard sample      Date: 2019-09-11 09:40  
 Bead Lot No.: 4627      Bead Expires: 2021-02-11  
 Cytometer Name:      Cytometer SN: B03002  
 Detector Configuration: Default Configuration  
 Loader Type: Semi Automatic

**Threshold**  
 Channel FICHeight: Mode: Manual    Value: 5000

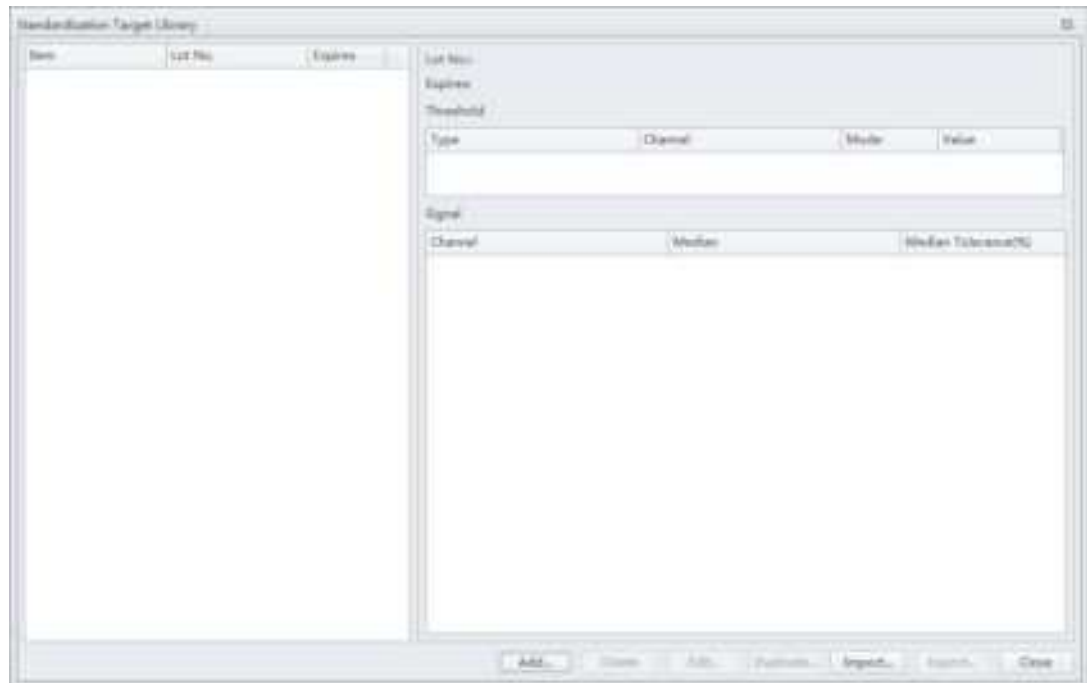
**Signal Value**

Assay	Lot	Median	Target Median	NDifference	Target Median	Result
FL1	119	202396.3	206917.6			1.76
FL2	127	1675096.0	1674380.0			-0.44
FL3	142	1674232.0	1674380.0			-0.08
FL4	179	1974658.0	2026689.2			-0.29
FL5	273	1207188.0	1279991.0			-0.27
FL6	472	4682507.0	4643872.0			-0.40
FL7	401	2116711.0	2179012.0			-0.70
APC	378	383945.4	384885.2			-0.27
APC-A750	90	1802946.0	1802946.0			0.00
APC-A750	636	4428701.0	4401771.0			0.61
PE-A530	88	808822.2	812222.2			-0.11
PE-A530	94	217950.0	241121.6			-0.29
PE-A600	174	404361.7	412796.7			-0.80
PE-A600	167	201280.7	202969.0			-0.81
PE-A750	278	401891.6	406317.0			-0.81

**Specifications**  
 Median: 5.00% ± NDifference Target Median: 5.00%

**Result**  
**Standardization Passed**

- 2 Select **Standardization Target Library** from the Settings menu.



- 3 Select . The Add Standardization Target Value window appears.

	Channel	Median	Median Tolerance(%)
<input checked="" type="checkbox"/>	FSC	0.00	5.00
<input type="checkbox"/>	SSC	0.00	5.00
<input type="checkbox"/>	Flc	0.00	5.00
<input type="checkbox"/>	mCherry	0.00	5.00
<input type="checkbox"/>	PerCF	0.00	5.00
<input type="checkbox"/>	APC	0.00	5.00
<input type="checkbox"/>	APC-A700	0.00	5.00
<input type="checkbox"/>	APC-A750	0.00	5.00
<input type="checkbox"/>	PE	0.00	5.00
<input type="checkbox"/>	ECD	0.00	5.00
<input type="checkbox"/>	PC5.5	0.00	5.00
<input type="checkbox"/>	PE-AF680	0.00	5.00
<input type="checkbox"/>	PC7	0.00	5.00
<input type="checkbox"/>	PB450	0.00	5.00
<input type="checkbox"/>	KO525	0.00	5.00
<input type="checkbox"/>	Violet510	0.00	5.00
<input type="checkbox"/>	Violet660	0.00	5.00

- 4 Enter the Item, Lot No., and Expire date from the drop downs located at the top of the Add Standardization Target Value window.

**NOTE** A single Lot No. can include several Items, but you cannot add duplicate Items under the same Lot No..

**NOTE** If the Lot No. selected already exists, the Expire date cannot be edited.

- 5 Select either Manual or Automatic threshold from the Standardization Test Setting or Acquisition Setting section of the window.

**NOTE** If you select Manual threshold, enter a value greater than 0, but less than 8,388,600.

**NOTE** Keep the threshold setting the same as previous Step 11 in [Generating Target Median Values](#).

**NOTE** Unchecking the *Use the same threshold setting for acquisition setting* checkbox allows you to specify custom threshold settings.

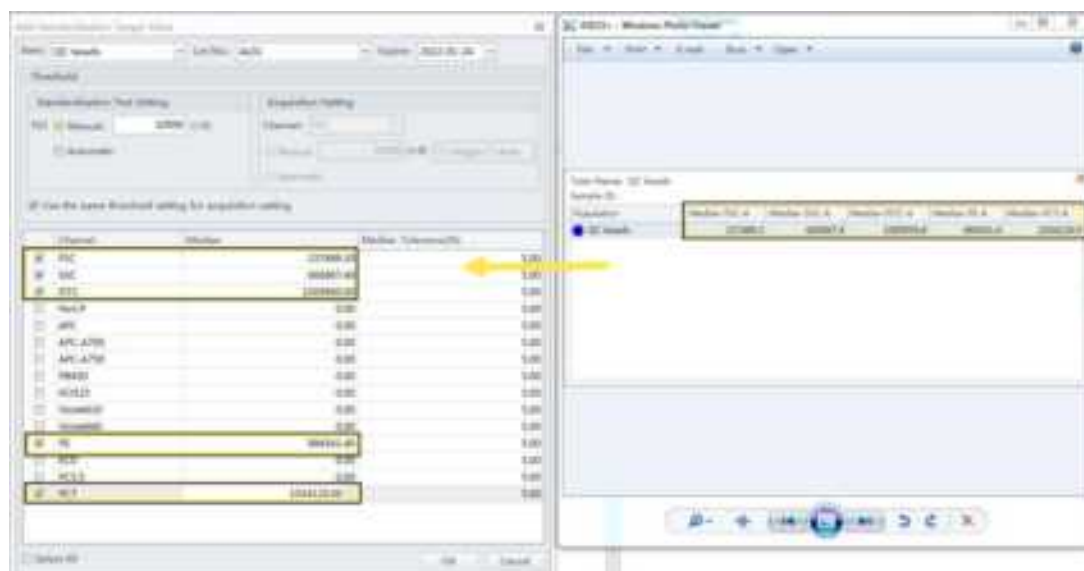
- 6 Set the channels to be standardized.

**NOTE** The contents of the channel, laser, and filter column come from the current detector configuration setting. Refer to [Verifying, Selecting, Editing, and Creating Detector Configuration in Data Acquisition and Sample Analysis](#).

**NOTE** Do not set the median tolerance range any lower than 5%.

**NOTE** FSC is a required channel.

- 7 Enter the target median values saved in Step 14 into the corresponding channels.



Or copy the median values from the previously exported CSV file and paste into the corresponding median column.

**NOTE** Verify that the target values are entered correctly.

- 8 Select **OK** to save the target value.

The saved results display in the Standardization Target Library window. This item is ready to be run through the Standardization experiment. Refer to [CHAPTER 5, Performing the Standardization](#).

- 9 Select **Close** to exit the Standardization Target Library window.

## Performing the Standardization

- 1 Select **Start QC/Standardization** in the QC/Standardization menu to access the Standardization screen.

**Standardization Report**

Task Item: Standard sample      Date: 2019-09-11 09:46  
 Seed Lot No.: 4627      Seed Expires: 2021-02-11  
 Cytometer Name:      Cytometer ID: 8103002  
 Detector Configuration: Default Configuration  
 Loader Type: Semi Automatic

**Threshold**  
 Channel FSCHeight Mode: Manual Value: 10000

**Signal Value**

Parameter	Gain	Median	Target Median	%Difference Target Median	Result
FSI	339	202396.9	200017.9	-1.18	Pass
SSC	322	1676099.0	1674540.0	-0.99	Pass
FTC	143	1674222.0	1674340.0	0.08	Pass
PI	179	197440.0	200000.0	-1.39	Pass
PC3	275	1207100.0	1275095.0	-6.27	Pass
PC3.2	472	4482507.0	4403872.0	-1.83	Pass
PC7	901	2133971.0	2170310.0	-1.70	Pass
APC	370	202940.0	204800.0	-0.27	Pass
APC-A750	90	190294.0	192294.0	-1.09	Pass
APC-A750	620	4428702.0	4401770.0	-0.61	Pass
PC4.0	88	803802.0	813212.0	-1.11	Pass
PC12.0	94	217700.0	241120.0	-1.09	Pass
Fluor405	154	404801.0	422760.7	-1.80	Pass
Fluor488	187	101280.0	103969.0	-1.64	Pass
Fluor780	270	403815.0	414017.0	-1.91	Pass

**Specifications**  
 Median: 5.00% ± %Difference Target Median ± 5.00%

**Result**  
**Standardization Passed**

- 2 Select the **Standardization** radio button.



- 3 Select the correct Lot No. from the Lot No. dropdown.



**NOTE** Ensure the Lot No. corresponds to the standardization sample that generated the target median values.

- 4 Select the Items to be standardized.

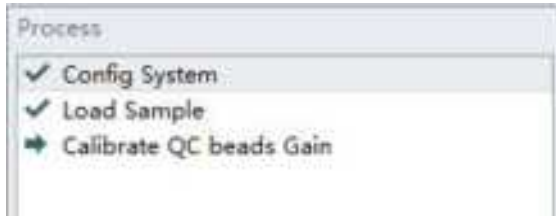


- 5 Select the proper detector configuration. Refer to [CHAPTER 6, Verifying, Selecting, Editing, and Creating Detector Configuration](#).

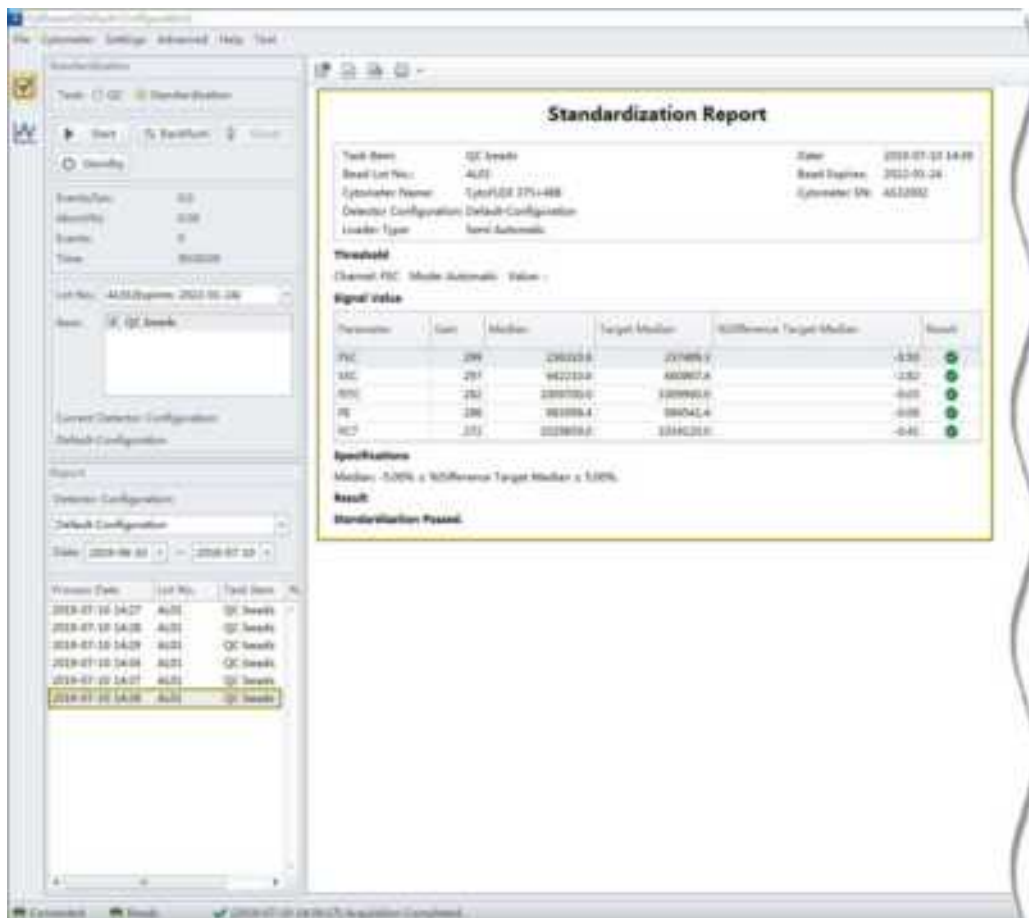
6 Select **Initialize**.

7 Select  **Start**.

The Process section of the screen displays the process details.

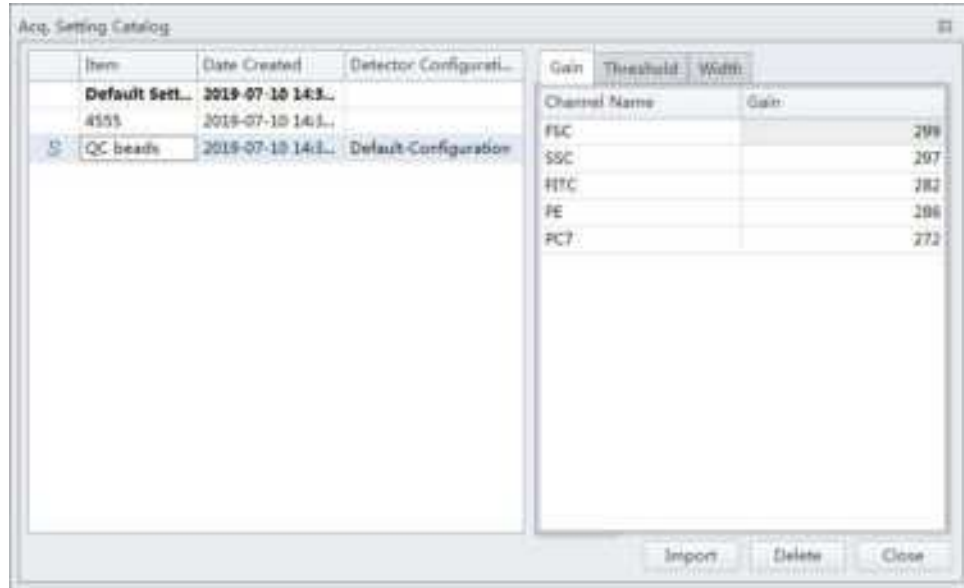


Once the process is complete, the Standardization Report displays.



**NOTE** The updated Standardization item is added to the Acquisition Catalog automatically and overwrites the previously existing standardized settings for this item.

- 8 Select **Acq. Setting Catalog** from the Cytometer menu to verify the gain settings. The Acq. Setting Catalog window appears.



**NOTE** S designates test items from Standardization.

- 9 Run Daily Clean. Refer to [CHAPTER 11, Daily Clean](#).

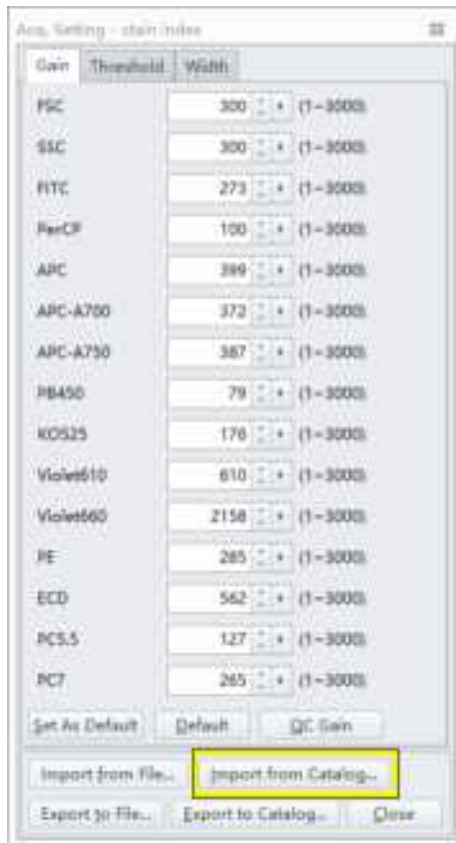
- 10 Select **Close QC/Standardization**.

## Applying the Standardized Acquisition Settings

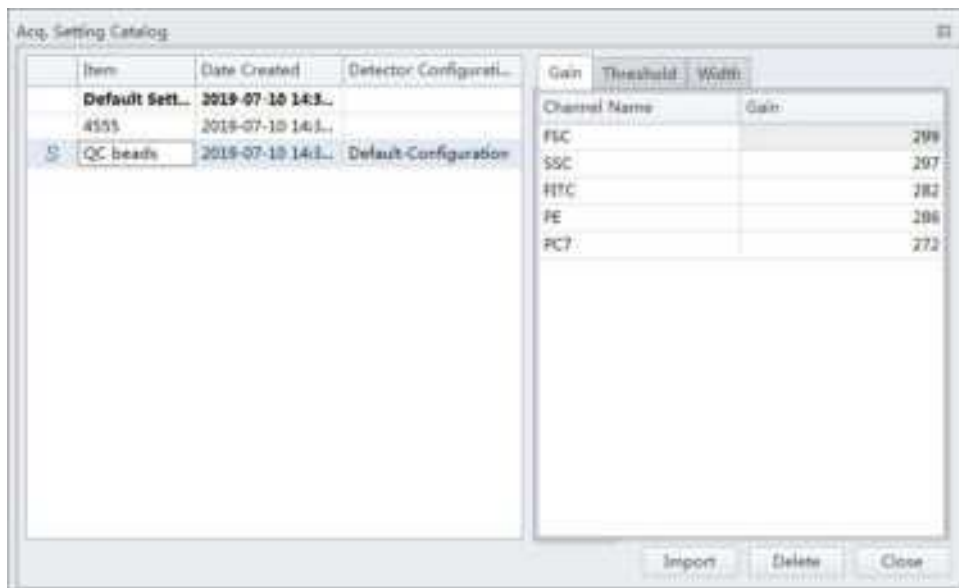
- 1 Open an experiment.

**NOTE** The corresponding compensation matrix should have been determined as the optimal settings. Refer to [CHAPTER 7, Compensation](#) for detailed instructions on setting compensation.

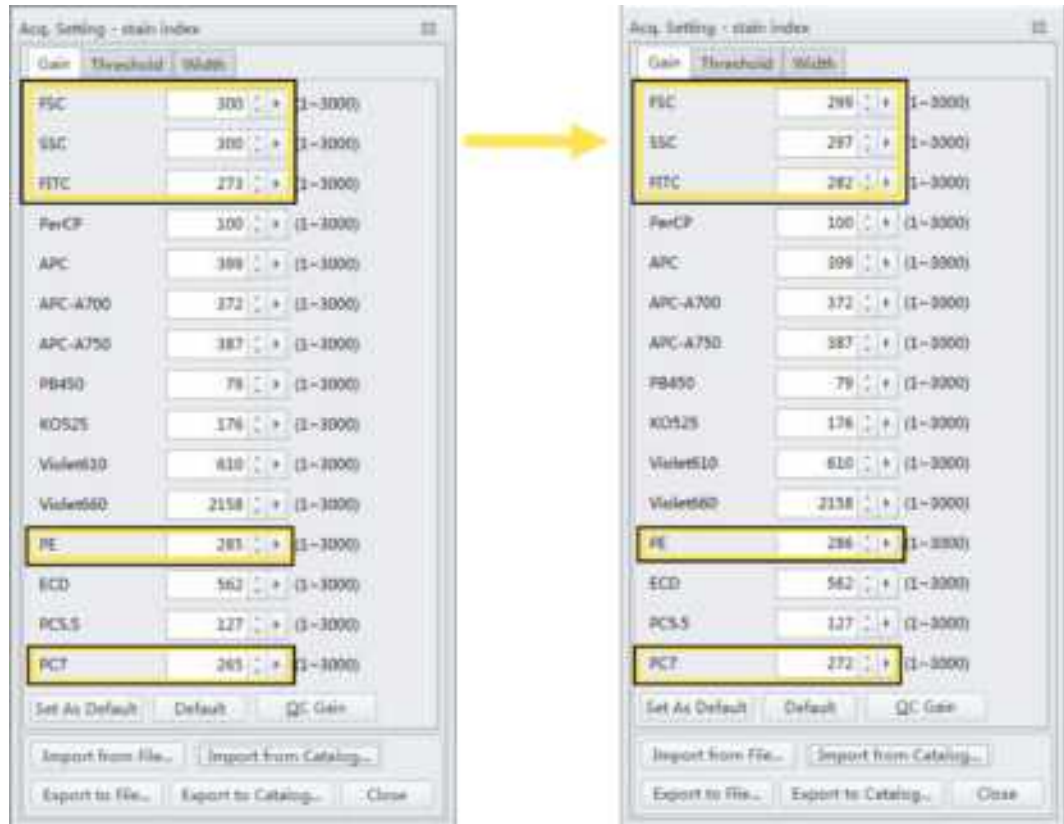
- 2 Select **Acq. Setting** from the Cytometer menu. The Acq. Setting window appears.



- 3 Select **Import from Catalog**. The Acq. Setting Catalog window appears.



- 4 Browse for the item to import and select **Import**.  
The standardized settings are applied to the sample tube.



The Information window appears to notify of the corresponding channels with the changed gain as a result of the Standardization.



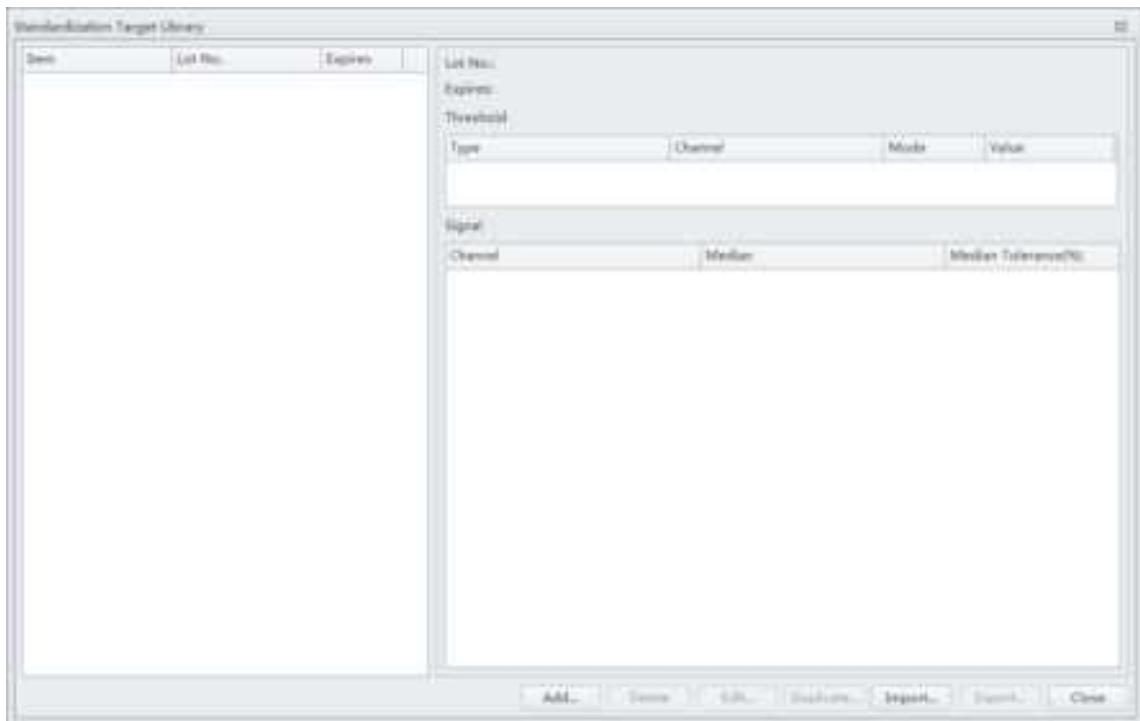
---

5 Select **OK**.

---

## Standardization Target Library

Select **Standardization Target Library...** from the Settings menu. The standardization Target Library window appears.




**NOTE** The Item name displays in the Acquisition Setting Catalog window as the saved acquisition setting name.

### Importing a Standardization Item


---

1 Select  on the Standardization Target Library window.

2 Browse for the Item to import and select .

The imported item displays at the top of the list in the Standardization Target Library window.

**NOTE** If the standardization item is existing in the target library, the importing will overwrite the existing item. The system will prompt to ask you to confirm.

- 
- 3 Select  to exit the Standardization Target Library window.
- 

### Exporting a Standardization Item

---


- 1 Browse for the Item to export.  
The available items display on the left panel of the Standardization Target Library window.
- 

- 2 Select  on the Standardization Target Library window.
- 

- 3 Navigate to the desired file path and select **Save**.

**NOTE** The standardization items save as .stgt file. This file can be used to standardize the settings between different instruments with the same laser and optical filter configuration.

---

- 4 Select  to exit the Standardization Target Library window.
- 

### Editing Standardization Item Parameters

---


- 1 Select an item from the Item column on the Standardization Target Library window and select .
- 

- 2 Edit the parameters for that item and select **OK**.

**NOTE** Task Item, Lot No., and Expire date cannot be edited.

---

- 3 Ensure the item parameters are correct then select  and save the file.
- 

- 4 Select  to exit the Standardization Target Library window.
- 

### Duplicating Standardization Items

---


- 1 Select an existing item from the Item column on the Standardization Target Library window and select .

---


2 Edit Item, Lot No., Expire date and the parameters for that item and select **OK**.

**NOTE** Perform a new standardization if the Lot No. of standardization sample is changed.

---

3 Ensure the item parameters are correct then select  and save the file.

---

4 Select  to exit the Standardization Target Library window.


---

### Deleting Standardization Items


---

1 Select an item from the Item column on the Standardization Target Library window.

---

2 Select . The confirm message *The target values will be permanently deleted. Are you sure?* displays. Select **Yes** to confirm.

---

3 Select  to exit the Standardization Target Library window.

---

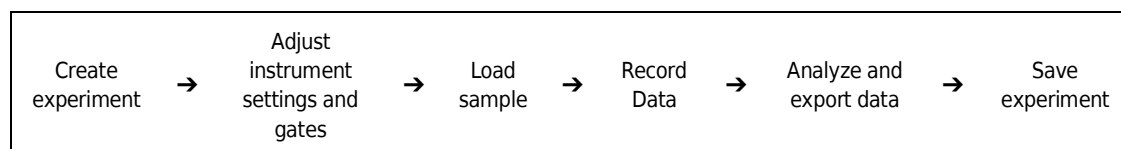
# Data Acquisition and Sample Analysis

## Overview

---

This chapter contains information on how to use your CytoFLEX and CytoFLEX LX flow cytometer, including data acquisition, analyzing and exporting results, and compensation procedures that will be executed manually during the process.

Workflow:



This chapter contains information on:

- [Creating an Experiment](#)
- [Configuring Acquisition Settings](#)
- [Load Sample and Record Data](#)
- [Analyzing and Exporting Data](#)
- [Saving the Experiment](#)

## Creating an Experiment

---

### Creating an Experiment [Without Plate Loader]

 **CAUTION**

**Risk of file corruption.** When modifying experiment (\*.xit) file names in Windows Explorer, ensure you modify the corresponding experiment folder name to match the new file name.

- 1 Open the CytExpert software and confirm that the instrument is connected. Refer to [CHAPTER 4, Logging into the Software](#).
- 2 Verify the detector configuration. Refer to [Verifying, Selecting, Editing, and Creating Detector Configuration](#).

---

**3** Verify the laser settings. Refer to [CHAPTER 6, Laser Settings](#).

---

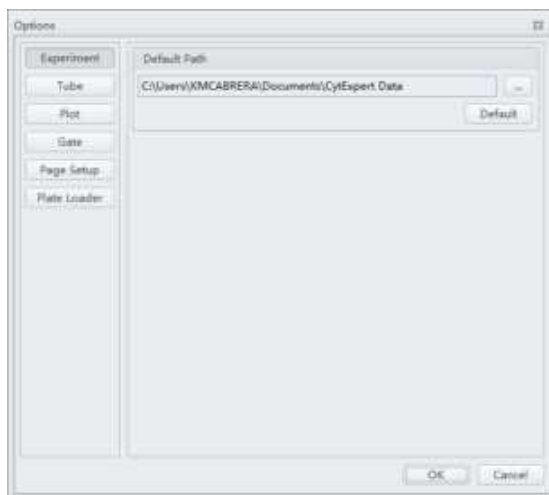
**4** Create or open an experiment using one of the following methods:

- Create a new experiment:
  - Select **New Experiment** on the Start page, specify the file path, and save the experiment.  
Or
  - Select **New Experiment** in the File menu, specify the file path, and save the experiment.
  
- Create a new experiment from a template:
  - Select **New Experiment from Template** on the Start page. Select **Browse** next to New Experiment and specify the file path for the new experiment, then select **Browse** next to Template and specify the file path to the existing template.  
Or
  - Select **New Experiment from Template** in the File menu, specify the file path and save the experiment.  
Or
  - Select the Template tab on the Start page and select the template from the list of recently used templates. Specify the file path and save the experiment.
  
- Open an existing experiment:
  - **If you are using either the CytExpert Default Software Option or the CytExpert User Management Software Option:** Select **Open Experiment** on the Start page, specify the file path and save the experiment.  
**If you are using the CytExpert Electronic Record Management Software Option:** Select **Open Experiment** on the Start page, specify the experiment file and open the experiment.  
Or
  - **If you are using either the CytExpert Default Software Option or the CytExpert User Management Software Option:** Select **Open Experiment** in the File menu, specify the path and save the experiment.  
**If you are using the CytExpert Electronic Record Management Software Option:** Select **Open Experiment** in the File menu, specify the experiment file and open the experiment.  
Or
  - **If you are using either the CytExpert Default Software Option or the CytExpert User Management Software Option:** Select the Experiment tab on the Start page and select the experiment from the list of recently opened experiments. Specify the file path and save the experiment.  
**If you are using the CytExpert Electronic Record Management Software Option:** Select the Experiment tab on the Start page and select the experiment from the list of recently opened experiments. Specify the experiment file and open the experiment.

**NOTE** Experiments are saved as an .xit file. Template are saved as an .xitm file.

**NOTE** If you are using either the **CytExpert Default Software Option** or the **CytExpert User Management Software Option**: If you need to change the default save path, select **Options** in the Settings menu and modify the Default Path displayed to the right of the Experiment tab. Then select **OK**.

If you are using the **CytExpert Electronic Record Management Software Option**: Select **File > Experiment Explorer** to modify any Experiment Directory sub folders for the Experiment. Refer to [APPENDIX B, Experiment Directory Management](#).



**NOTE** If desired, import saved settings/standardization settings from the catalog.

## Creating an Experiment [With Plate Loader]

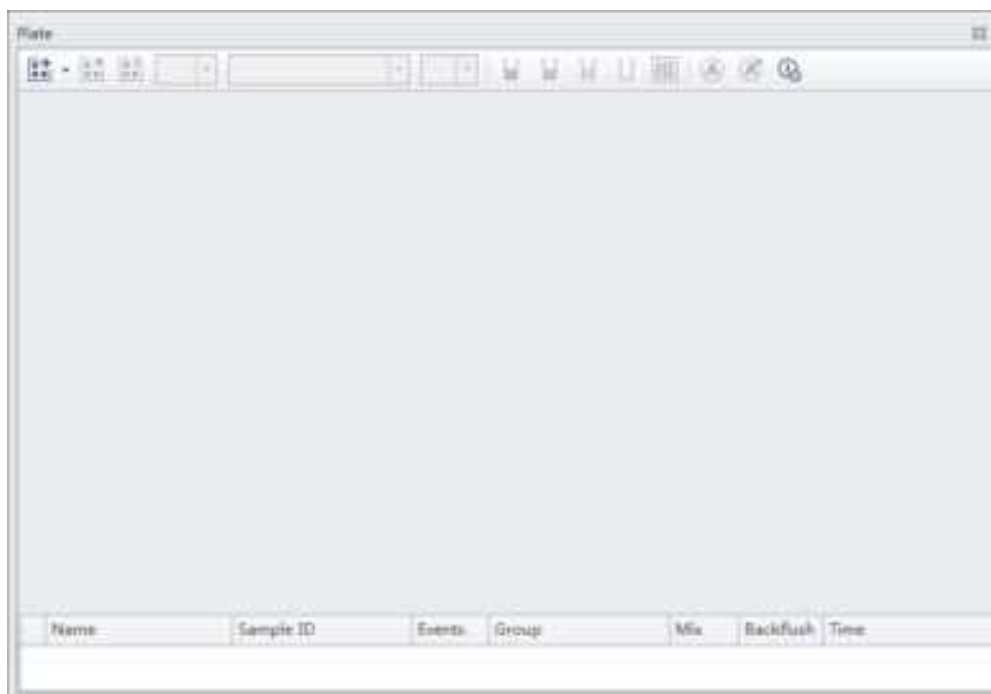
### CAUTION

**Risk of file corruption. When modifying file names in Windows Explorer, ensure you modify the corresponding folder name to match the new file name.**

- 1 Create an experiment. Refer to [CHAPTER 6, Creating an Experiment](#).

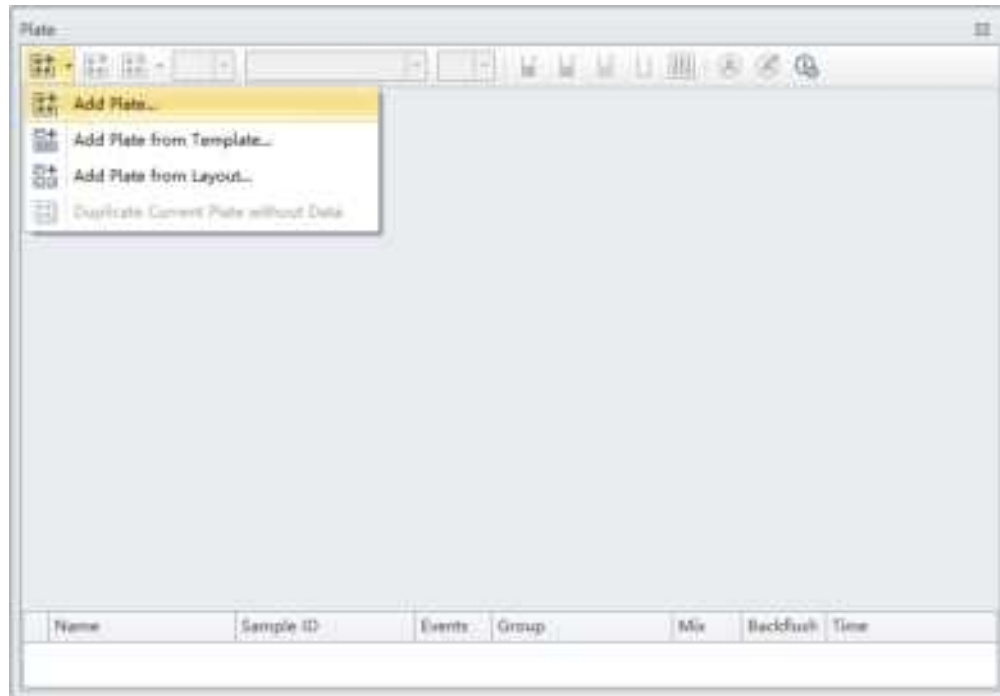
- 2 Select . The Plate window appears.

[CytoFLEX LX Shown]

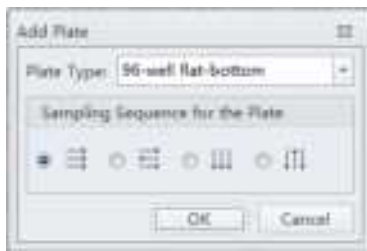


- 3 Select the Add Plate dropdown and select **Add Plate**.

[CytoFLEX LX Shown]



The Add Plate window appears.



**NOTE** Select **Add Plate from Template** to add a plate template with preset plate settings.

**NOTE** Select **Duplicate Current Plate without Data** to create a copy of the selected plate without data.

**NOTE** Select **Add Plate from Layout** to create a plate from a preset .csv file. The CSV file can be

generated by selecting , or self-defined by other tools like Excel or Notepad.

When you create a CSV file, make sure to follow the example:

1. In the first row, enter the following column titles WellLabel, TubeName, SampleID, Group in sequence as shown in [Figure 6.1](#). The table header cannot be customized.
2. In the WellLabel column, a maximum of 96 wells can be defined, beginning with A1-A12, B1-B12, and so on.

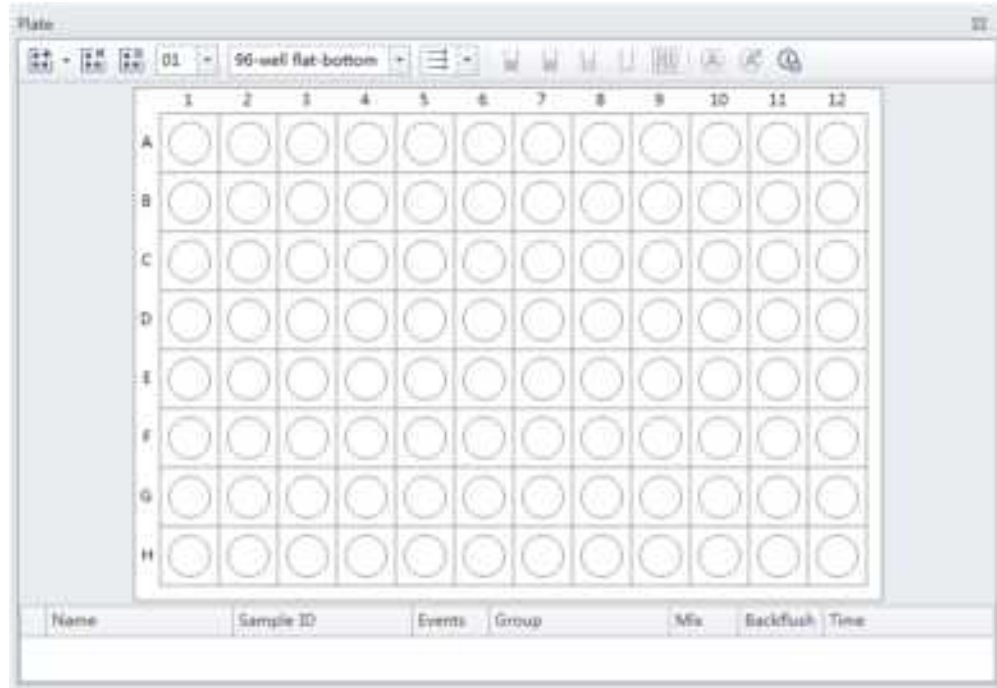
**Figure 6.1** CSV template

	A	B	C	D
1	WellLabel	TubeName	SampleID	Group
2	A1			
3	A2			
4	A3			
5	A4			
6	A5			
7	A6			
8	A7			
9	A8			
10	A9			
11	A10			
12	A11			
13	A12			
14	B1			
15	B2			
16	B3			
17	B4			

- 
- 4 Select the Plate type from the dropdown.



- 5 Select the direction of the workflow from the sampling sequence from the plate section of the window. The Plate window appears.

[CytoFLEX LX Shown]

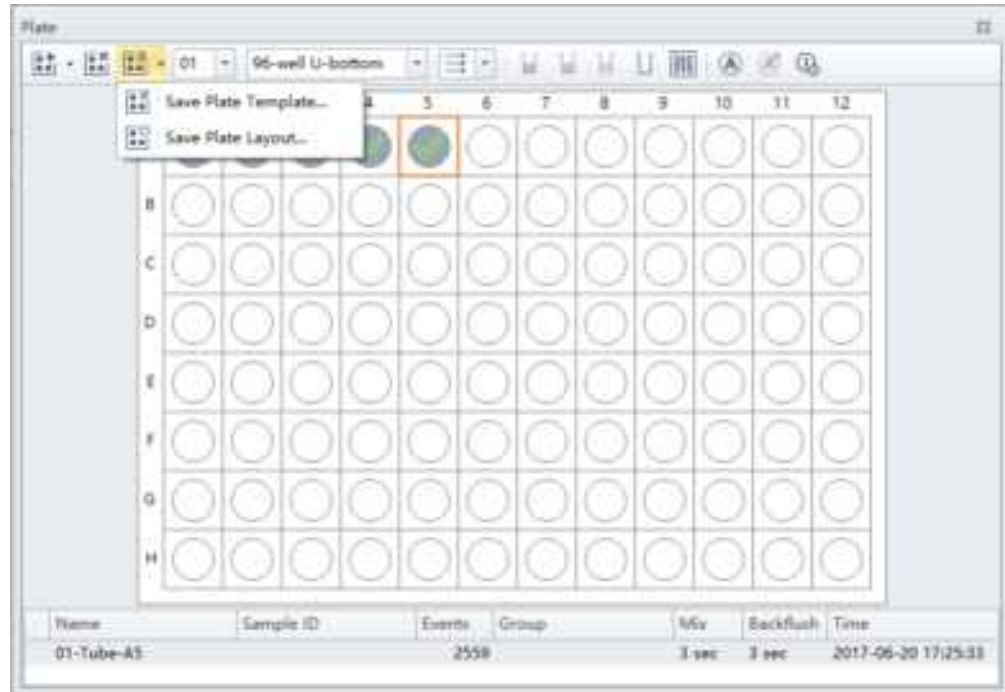


- 6 If you need to automatically turn off the cytometer after auto acquisition is complete [CytoFLEX LX Only]:
- Ensure you set the last sample wells with the appropriate number of cleaning agent wells and deionized water wells.

b. Select  .

**NOTE** A gray background (  ) indicates auto shutdown is disabled. A yellow background (  ) indicates auto shutdown is enabled.

**NOTE** Select **Save Plate Template** to save the acquisition settings as a template in SCTM format.  
Select **Save Plate Layout** to save the name, sample ID, or metadata as a layout in CSV format.

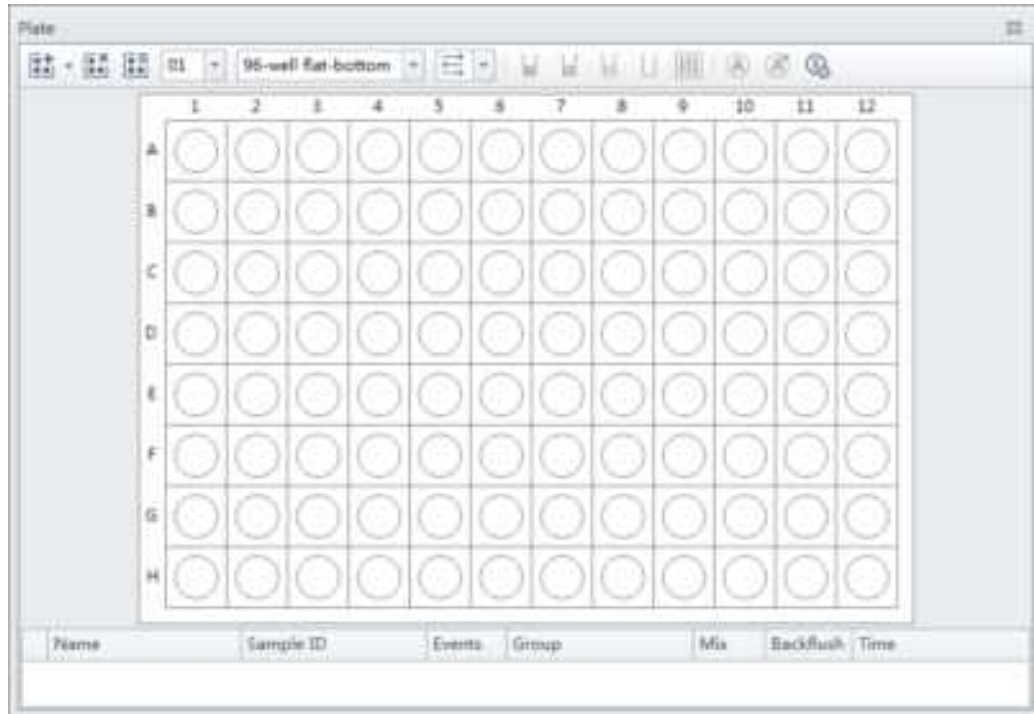










**7** Select **OK**.


## Setting Sample Wells

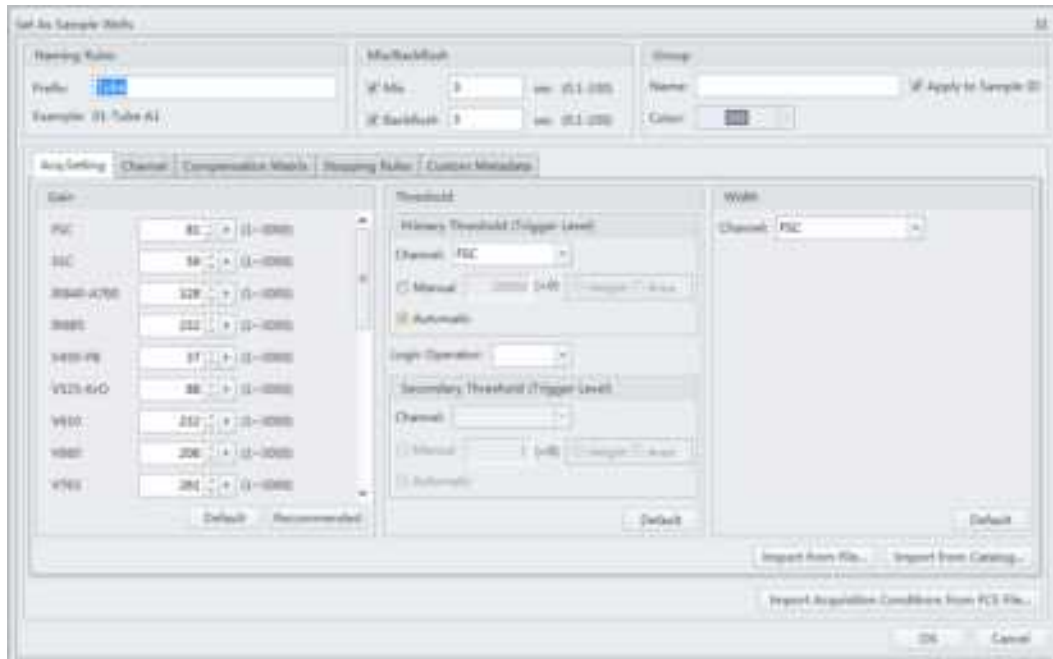
Once the plate protocol is created, the plate window appears. Refer to [Figure 6.2](#).

**Figure 6.2** Plate Window [CytoFLEX LX Shown]



	Empty well.
	The well with color is set as sample well, but is not set for Auto Record.
	The well is set as sample well, and is ready for Auto Record. The number labeled at the right bottom shows the order of auto record.
	Cleaning Agent well.
	Deionized water well.
	A blue check mark means the data is acquired, not recorded.
	A green check mark means the data is recorded.
	A red cross mark means the data is recorded by Auto Record mode. But the acquisition is terminated abnormally. For example, the well is skipped or the acquisition is manually stopped.

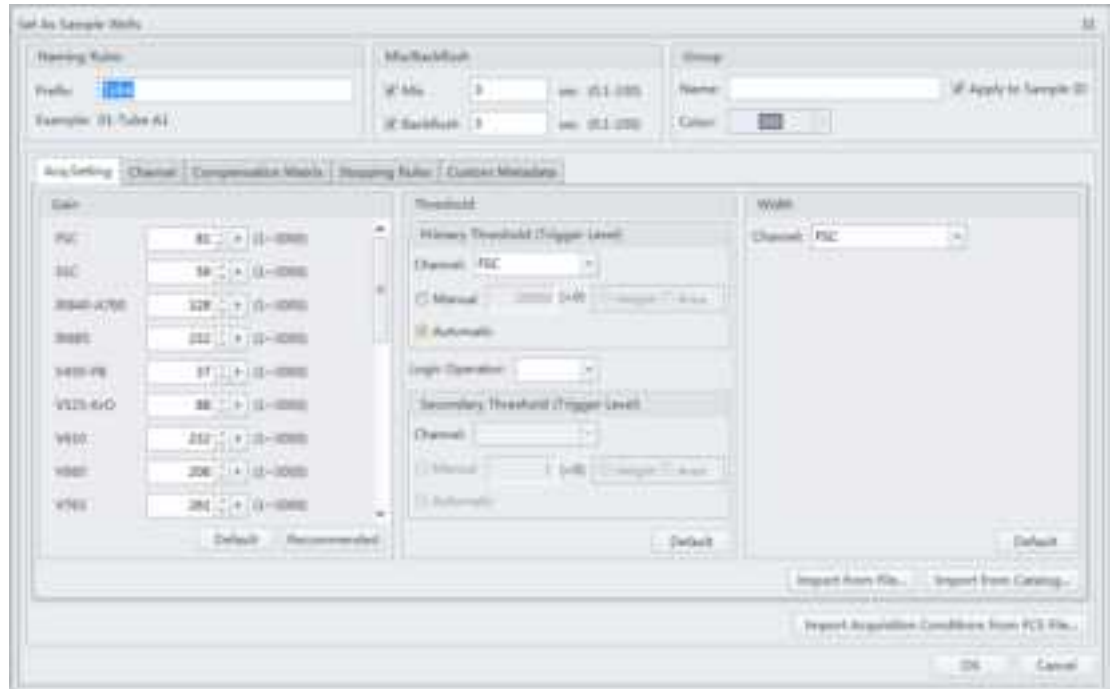
- 1 Left-click and drag your mouse to highlight the desired wells or hold the Control key and select each desired well.
- 2 Select  or right-click the selected wells and select **Set As Sample Wells**. The Set As Sample Wells window appears.



**NOTE** Select  or right-click and select **Set as Empty Wells** to reset selected wells as empty.

- 3 Enter the name in the Prefix box in the Naming Rules section of the window.
- 4 Select the desired Mix and Backflush duration from the Mix/Backflush section of the window.
- 5 Enter the Group Name in the Name box in the Group section of the window.
- 6 Select the sample well color using the color dropdown under the Group section of the window.

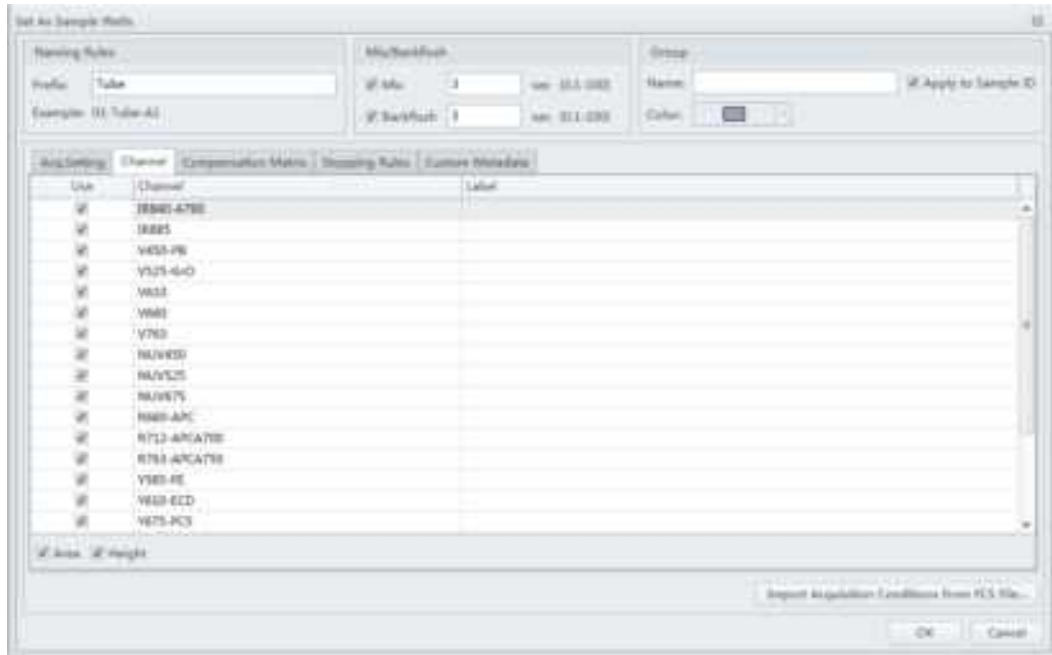
7 Select the desired acquisition settings under the Acq. Setting tab.



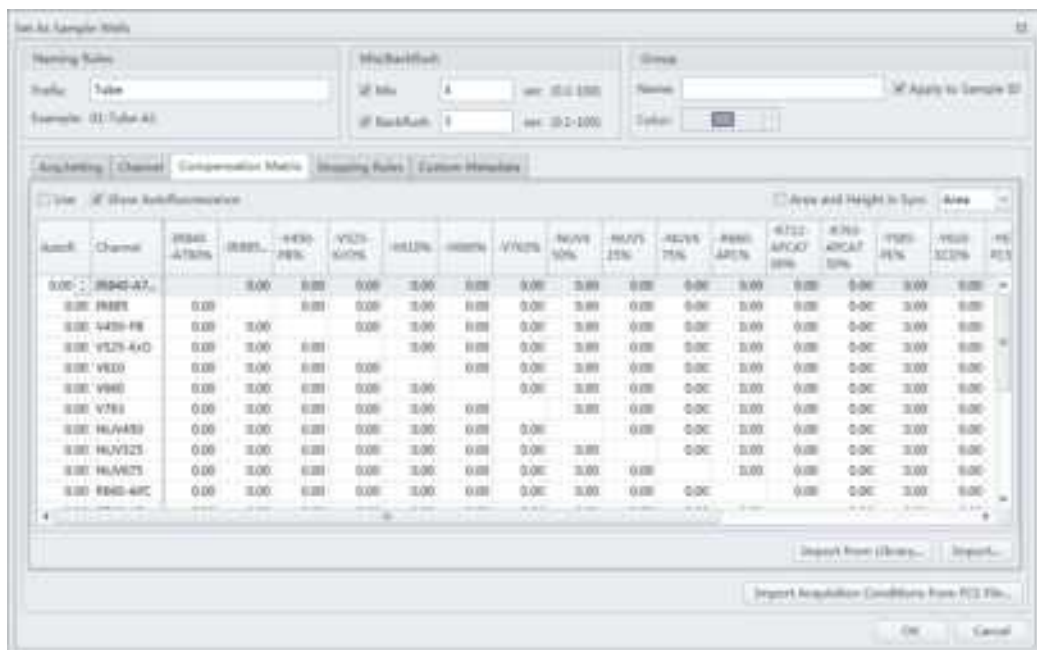
**NOTE** Select **Import from File** to import the settings from a FCS file.

**NOTE** If desired, import saved settings/standardization settings from the catalog.

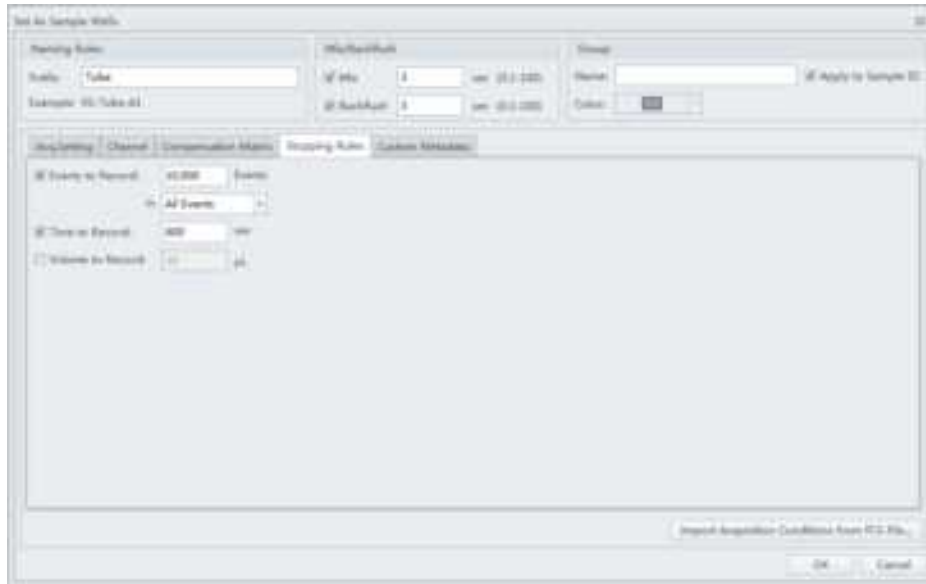
- Select the channels and create label names under the Channel tab.



- Set compensation under the Compensation Matrix tab. Refer to [CHAPTER 7, Compensation](#) for detailed instructions on setting compensation.

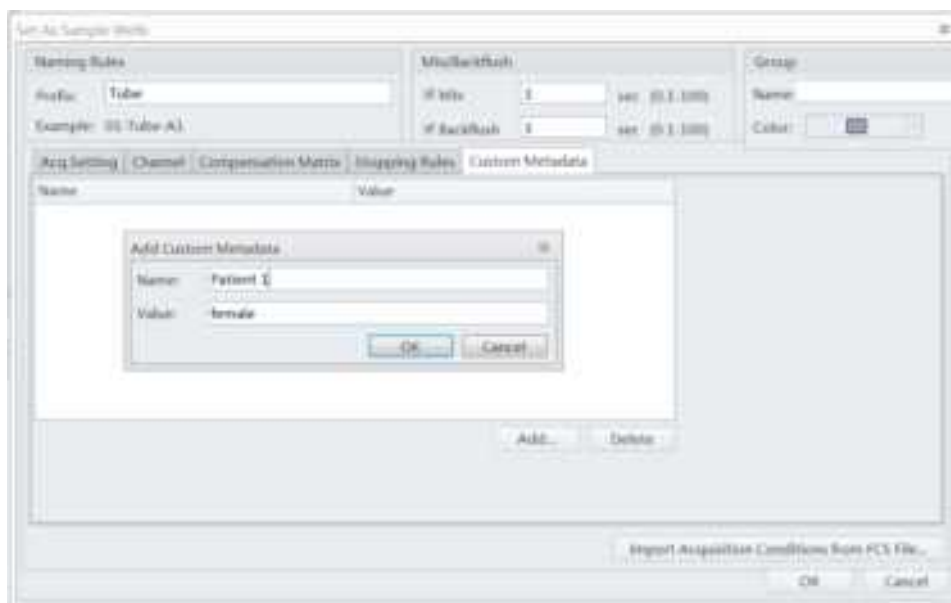


10 Select **Events to Record**, **Time to Record**, or **Volume to Record** under the Stopping Rules tab.



**NOTE** Beckman Coulter recommends setting an acquisition time limit to stop the acquisition if the event limit cannot be reached.

11 Create the desired name and value under the Custom Metadata tab.

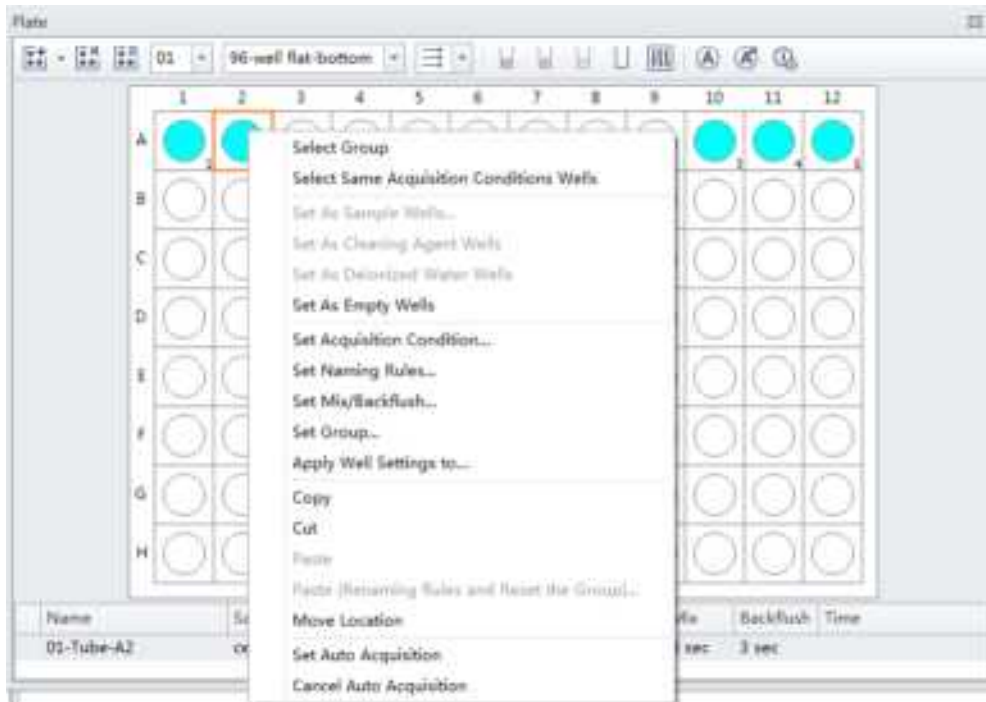


12 Select **OK**.

## Modifying Well Settings

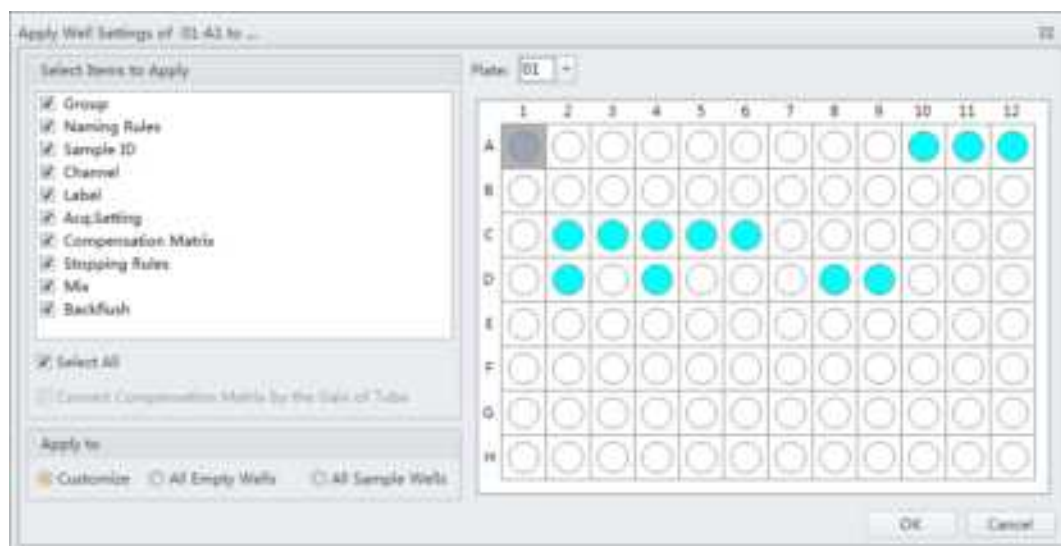
If any well settings require modification, right-click the sample well and select the setting to change.

[CytoFLEX LX Shown]



## Applying Existing Well Settings to Additional Wells

- 1 Right-click the well with the desired settings and select **Apply Well Settings to**. The Apply Well Settings of window appears.



**NOTE** The *Convert Compensation Matrix by the Gain of Tube* checkbox is only available when Acq. Setting is deselected. Selecting the *Convert Compensation Matrix by the Gain of Tube* checkbox converts the compensation matrix automatically by the gain of the well selected.

- 2 Select the wells to apply the well settings to.

**NOTE** Select the **Customize** option to select individual wells to apply the settings to. Select the **All Empty Wells** option to apply the settings to all remaining empty wells. Select the **All Sample Wells** option to apply the settings to all existing colored sample wells. You cannot apply settings to wells that already contain data.

- 3 Checkmark which settings to apply from the Select Items to Apply section of the window.

### NOTE

- If Group and Name Rule are selected, the settings can be applied to any wells, and empty wells will be set as sample wells after applied.
- If Group and Name Rule are not selected, the settings can only be applied to sample wells.

## Copying, Cutting, and Pasting Wells

- 1 Left-click and drag your mouse to highlight the desired wells or hold the Control key and select each desired well.

- 
- 2 Right-click and select **Copy** or **Cut**.

**NOTE** When **Copy** or **Cut** is selected, the well displays as follows:



- 
- 3 Right-click an empty well and select **Paste**.

**NOTE** The same number of wells will paste in the same orientation the wells were selected.

---

### Moving the Location of a Well

- 
- 1 Right-click the desired well to move and select **Move location**.

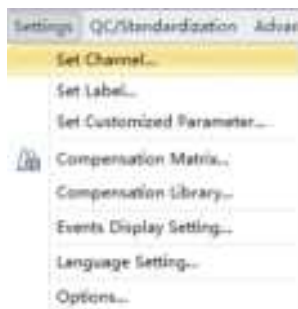
**NOTE** When **Move location** is selected, the well displays as follows:



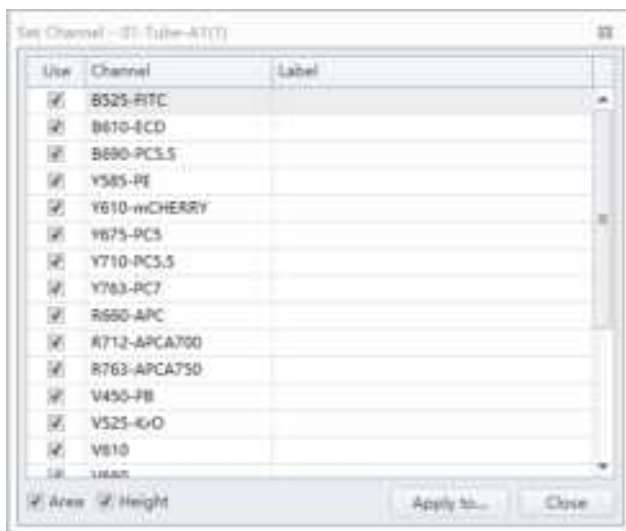
- 
- 2 Select the new well location. The well will automatically move to the new selected location.
- 

## Setting the Channel and Label

- 
- 1 Select **Set Channel** in the Settings menu. The Set Channel window appears.

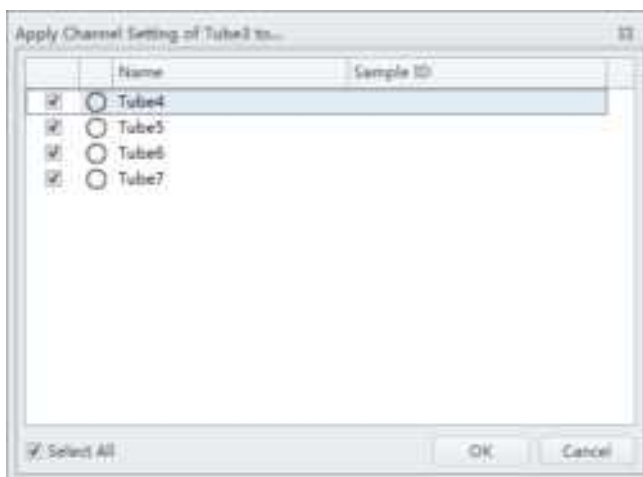


- 2 In the Set Channel window, modify which channels are used and how they are displayed.
- Select the channel signal check box, then you can add the reagent name in the Label column. The information you add appears in the corresponding axis of the relevant plot in the plot area. Unselected channel signals are not stored in the data file.



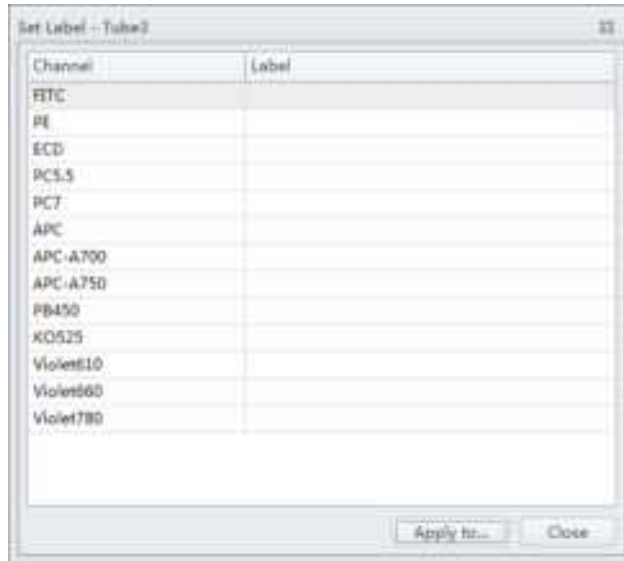
**NOTE** You can select which signal type to use Height or Area.

- Select **Apply to**. The Apply Channel Setting window appears.



- Select the tubes to apply the channel settings to and select **OK**.

- d. If you only need to modify the label name, select **Set Label** in the Settings menu to make the required changes. The Set Label screen appears. The Set Label screen does not allow you to select which channels to use, but it does allow you to apply the modified label to all the sample tubes.



- e. Select **Apply to**. The Apply Label Setting window appears.





- f. Select the tubes to apply the label settings to and select **OK**.

## Creating Plots and Gates

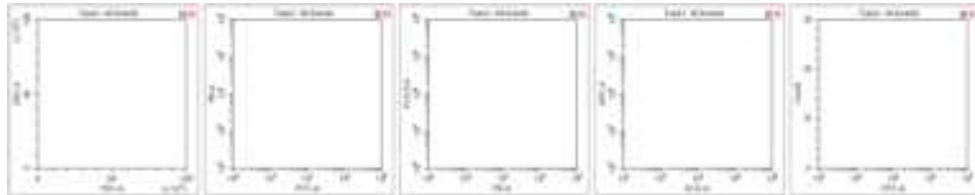
**IMPORTANT** The maximum number of elements allowed in an experiment is 200. Elements include plots, statistics tables, and gate hierarchy tables.

**IMPORTANT** The maximum number of gates allowed in an experiment is 200.

- 1 Use the plotting controls (see [Figure 2.1](#)) in the plot area to create plots and gates and to generate graphs as shown.

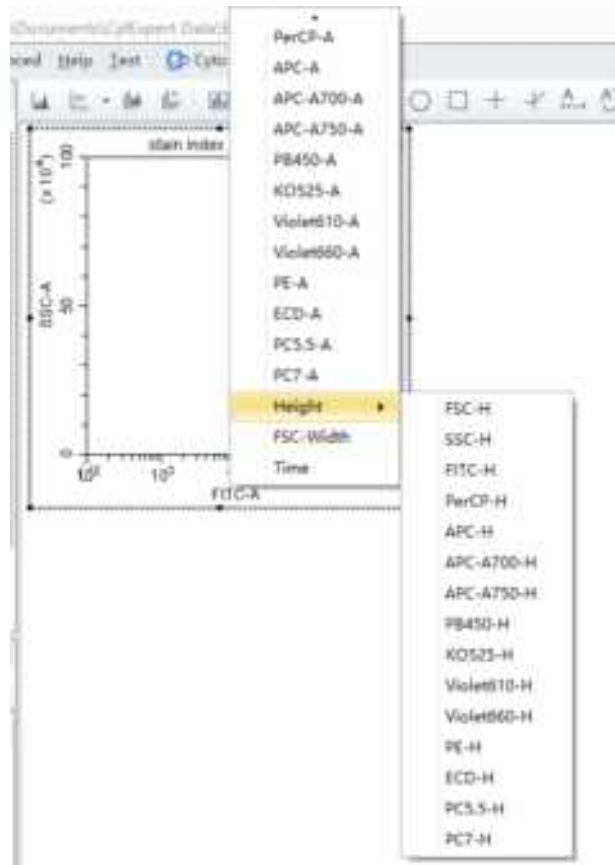
Use the   icons to generate histograms, dot plots, density plots, pseudo color plots, and contour plot.

The experiment uses scatter plots, histograms, polygon gating, four-quadrant gating, and line-segment gating.




- a. After selecting a plot, click and drag the mouse to adjust the position and select and drag the sizing handles at the edge of the graph to adjust the size of the graph.

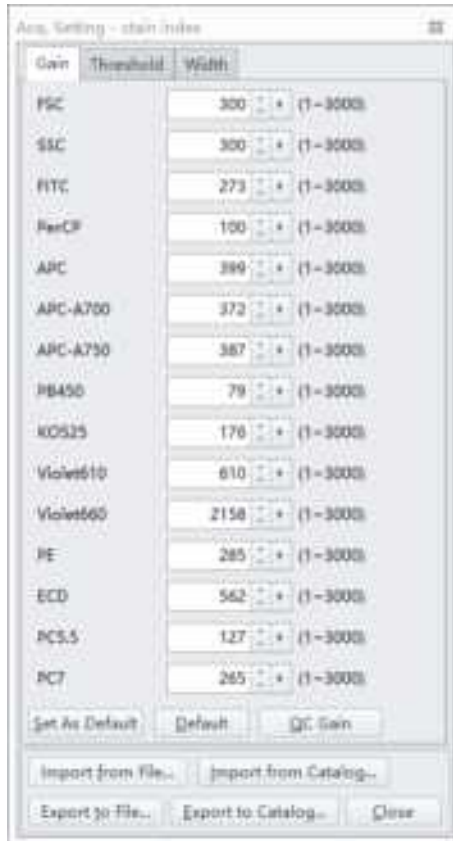
- b. Select an axis name to change which channel is displayed. An “A” after the channel name indicates signal pulse area, while an “H” indicates height. The default setting is “A”.



**NOTE** To modify the default settings, select **Options** in the Settings menu. The Options window appears. Select **Plot** on the left side of the Options window. Under the Signal section of the window, change the Main Channel default by selecting the **Height** or **Area**.

**NOTE** When using both Height and Area signals, ensure the gain setting is set to where the Height signal does not reach its upper range.

- c. Signal width can be used as a tool for doublet discrimination and to differentiate somatic cell adhesion. If necessary, select  to open the Acq. Setting window.



- d. Select the **Width** tab, and select a channel with the required signal width.



- e. Plot properties can be configured to display axes in Log, Log-Linear, or Linear format.
- 1) Double-click the plot or right-click the plot and select **Property** from the drop-down menu. The Plot Property screen appears.



- 2) Select whether to display the axes in logarithmic or linear format for both the X-axis and Y-axis. Enter a value for log-linear coefficient if the log-linear view is desired.
- 3) Select **Close**.

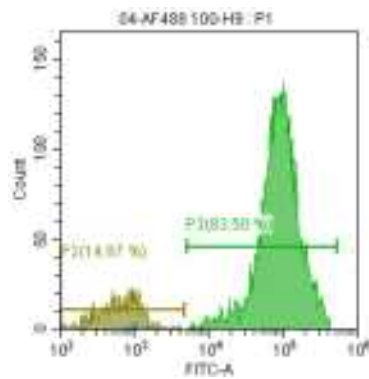
Or

Select the logarithmic axis on the plot. The slider appears. Drag the slider along the axis to change the log-linear coefficient and view events that are not shown, including events with negative values.

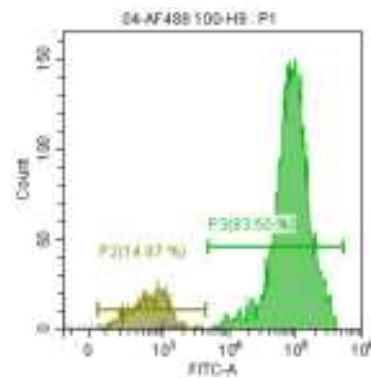
**NOTE** The log-linear slider is also available during data acquisition.

**NOTE** To reset the axis back to logarithmic, right-click on the axis and select **Property**. Select **X axis Default** or **Y axis Default** to reset the axis.

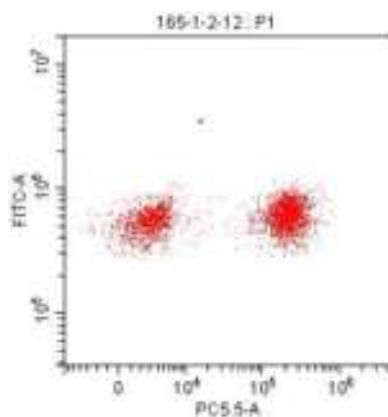
Histogram with logarithmic



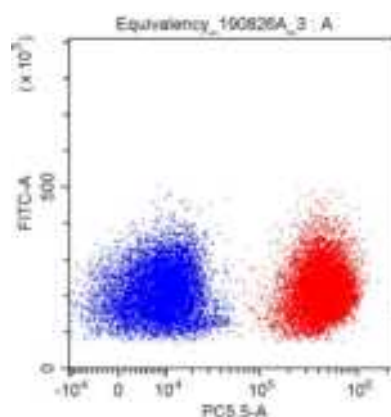
Histogram with log-linear







Dot plot with logarithmic

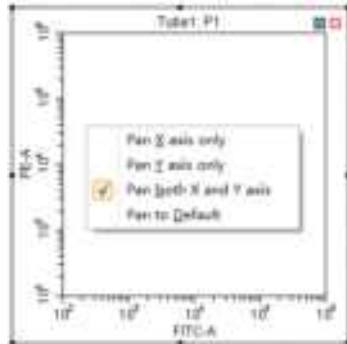



Dot plot with log-linear



- f. You can adjust axis ranges using the pan axis display controls located at the top of the screen.
  - Select , to zoom-in and define which area of a plot to enlarge. The selected area can be magnified to fill the entire graph. By selecting the zoom-out function, you can click on the graph and restore the plot to its original appearance before magnification.

- Select   to shift the axes. The mouse pointer appears as a hand. It allows you to drag the graph to reveal the axis segment you need.
  -  Pan: Modifies the axis display range dimensions when panning both axes. When the pan control is selected, you can right-click the graph and select which axis you need to adjust when dragging. You can also pan directly to the default axis range.



-  Single side pan: Modifies the axis display range dimensions when panning one axis.


**NOTE** Only the low end of the axis can be adjusted by the single side pan tool.

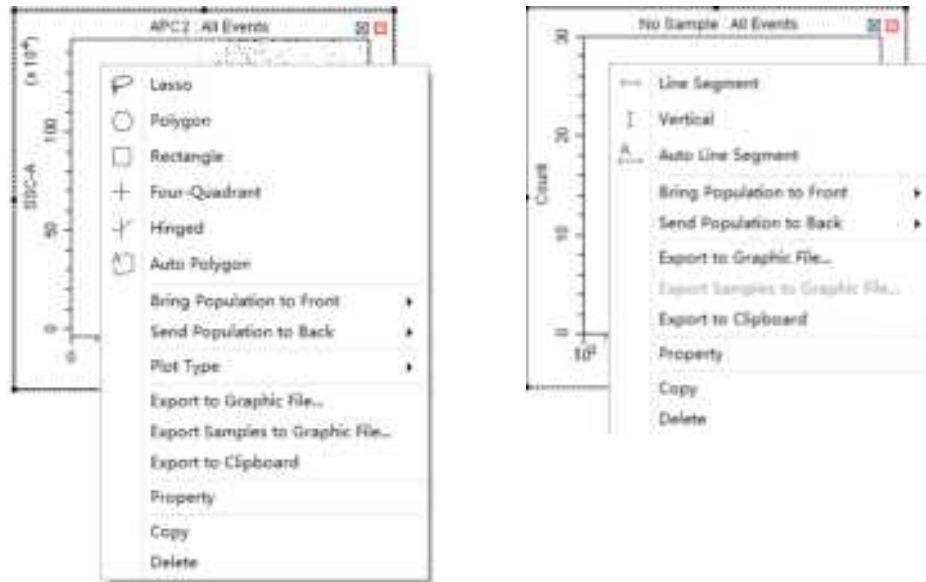
- Double-click the border area of the plot to open the Plot Property window, or right-click the plot, then select **Property** to open the same Plot Property window.
- In the Plot Property window, manually enter the minimum and maximum display values for the X- and Y-axes. You can also select **Fit With Sample** to let the software automatically adjust the lower limit according to the signal and perform the corresponding log-linear transformation. The X- and Y-axes **Default** settings are the default parameters. The default parameters are 100-1,000,000.

**NOTE** Select **Fit With Sample** to identify the signal's lower limit, adjusting automatically as warranted. Selecting this item is recommended whenever the signal appears to be relatively low.

**NOTE** Select **Auto** to automatically set the upper and lower display limits of the axes based on the data already collected.

**NOTE** Select **Options** in the Settings menu, then select **Plot** to modify the default setting of the axis range under the Axis Default Setting section of the window.

- 2 To create gates, use the  control buttons or right-click the plot and select the gate type required. Gates can be set according to different requirements to differentiate cell populations.



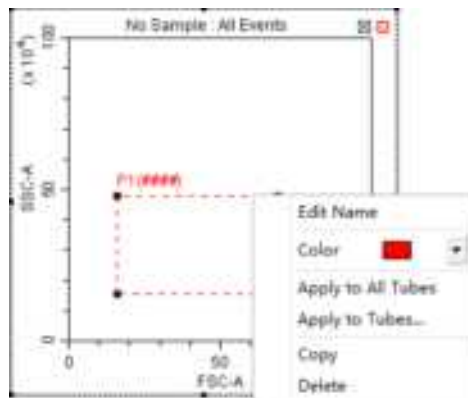
**NOTE** To add a vertex to a polygon gate:

1. Select the gate.
2. Hover your cursor over the perimeter of the gate until the cursor changes to the hand icon.
3. Select the desired location for the new gate vertex.

**NOTE** A newly created gate becomes a subset of the plot where it appears. The relationship between parent and progeny/daughter gates can be changed when a displayed gate is subsequently modified.

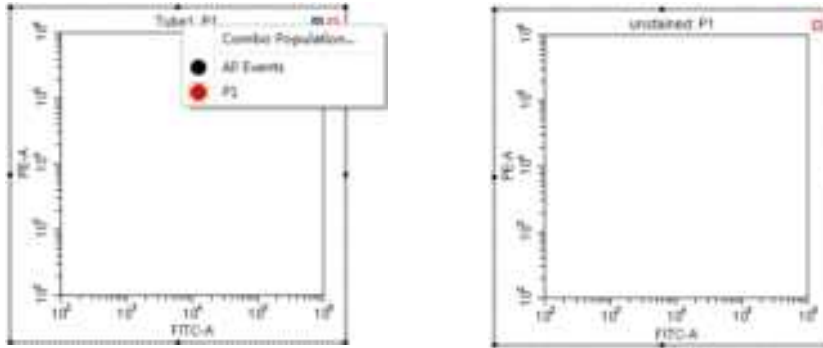
The position of the same gate in different sample tubes may vary. To change the position of a gate and apply the change to all sample tubes accordingly, you can right-click the gate and select **Apply to All Tubes**.

You can also apply the change to select tubes by selecting **Apply to Tubes**.



3 Select the gates to display.

- a. Select the heading area of the plot, select the parent population/gate to display in the plot from the drop-down menu. The selected parent gate appears in the tab area of the plot.



**NOTE** The CytExpert software will not list gates which would create circular gating logic.

Figure 6.3 shows all gates defined in the example experiment below. Note that the only gate option in plot 1 of Figure 6.4 is P2 for the following reasons:

- Plot 1 cannot be gated on P1 because P1 is on that plot.
- Plot 1 cannot be gated on P2 because P2 is gated on P1.
- Plot 1 cannot be gated on the P2 OR P1 combo population because the gate logic contains P1.

Figure 6.3 All Gates - Example Experiment

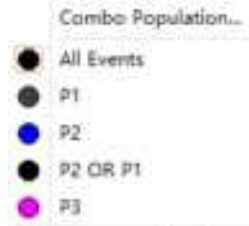
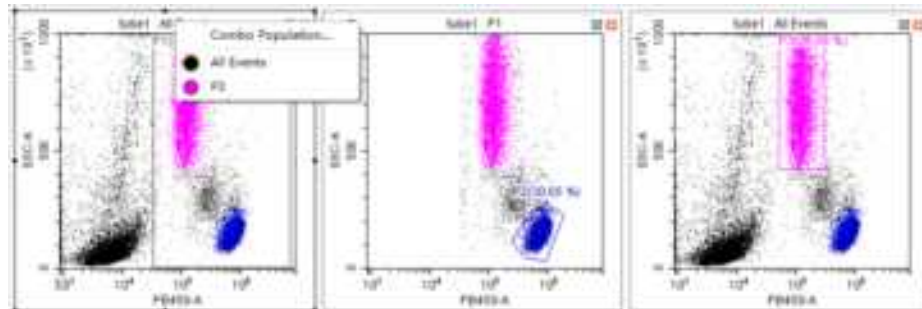



Figure 6.4 Circular Gating Logic - Example Experiment



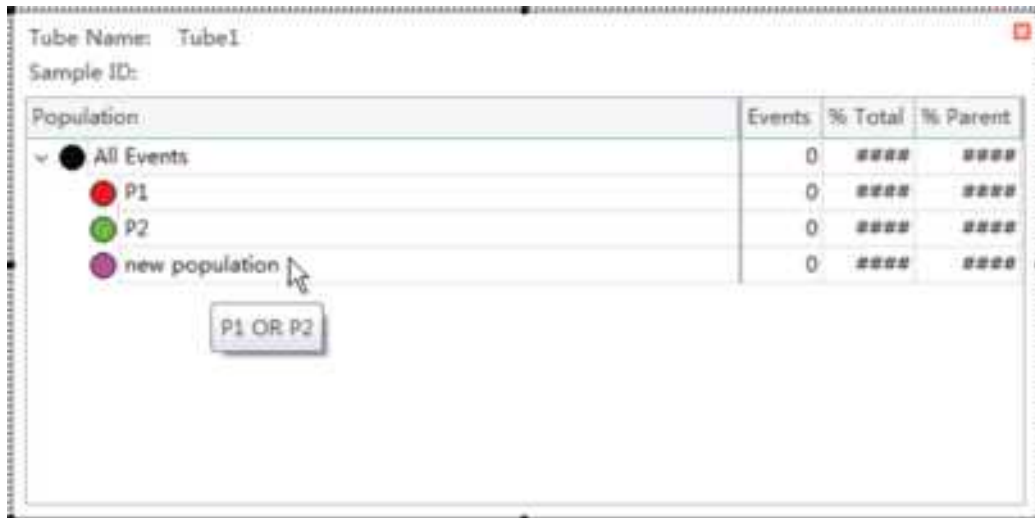
- b. If necessary, you can select the **Combo Population** option from the drop-down menu to create a combination gate, using the Boolean relationships “and”, “or”, and “not” to produce a new gate. You can also select the population color or change the gate name.



- “And” indicates that all selections must be satisfied. For example, “P1 and P2” means that the data for the newly added gate represent the intersection of P1 and P2.
- “Or” indicates that only one of the selections needs to be satisfied. For example, “P1 or P2” means that the data for the newly added gate represent the union of P1 and P2.
- “Not” indicates exclusion from the selection. For example, “Not P1” means that the data for the newly added gate represent the events that are not part of P1.

- 
- 4 Select  to display the population hierarchy.

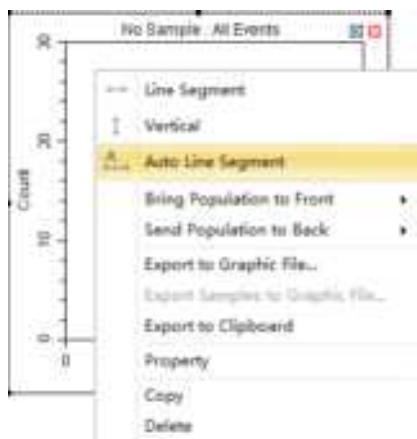
The Population Hierarchy function allows you to view how gates rank in relation to one another. To change the display color, double-click the default color and select the desired color from the drop-down color palette. To change the name of each gate, double-click the name of the desired gate. By hovering your mouse pointer over a combo population whose display name has just been changed, you can view its corresponding Boolean logical operation.



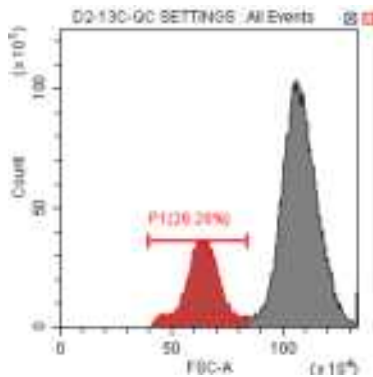
## Creating and Adjusting Auto Gates


There are two types of autogates available in the CytExpert software: auto line segment and auto polygon.

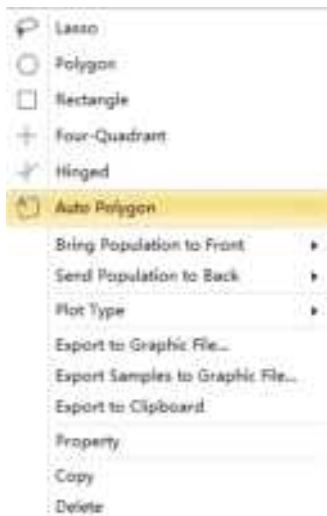
To create an auto line segment gate, select  from the toolbar or right-click on the histogram and select **Auto Line Segment** from the drop down menu.



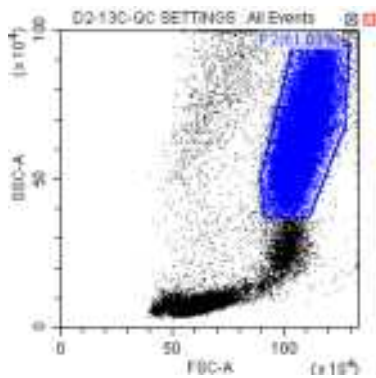
Select the population you want to gate in the histogram to automatically gate that population.



To create an auto polygon gate, select  from the toolbar or right-click on the 2D plot and select **Auto Polygon** from the drop down menu.



Select the population you want to gate in the 2-D plot. The gate will automatically be drawn to fit the population.



**NOTE** To add a vertex to an auto polygon gate:

1. Select the gate.
2. Hover your cursor over the perimeter of the gate until the cursor changes to the hand icon.
3. Select the desired location for the new gate vertex.

### Turning Auto Recalculate On/Off

When auto recalculate is turned on, all autogates will recalculate when:

- The current tube is changed
- Compensation is changed
- Gating is changed
- Collection stops
- An FCS file is imported to the tube or well

Auto recalculate turns off after a gate is moved or the size of a gate is altered. You must select **Auto Recalculate** from the auto gate menu again to turn auto recalculate back on.

**NOTE** Auto recalculate turns on after adjusting movement or extent.

Right-click an autogate and select **Auto Recalculate** from the auto gate menu to toggle auto recalculate on and off.



## Adjusting Autogate Movement and Extent

**Movement** — The distance an autogate can move to find the target population.

To adjust movement, right-click an autogate and drag the Movement handle in the auto gate menu left and right.



**NOTE** The default value setting for movement is 20 units. The minimum value setting for movement is 0 units and the maximum value setting for movement is 100 units.

If a target population is consistently in the same location, movement is not needed. However, if a target population is periodically missing from some samples, or events are rare, movement can be used to move the gate within a certain percentage of its axis to capture the correct population. Refer to [Figure 6.5](#) for an example of the default movement setting. Refer to [Figure 6.6](#) for an example of the maximum movement setting.

**Figure 6.5** Movement - Default Setting

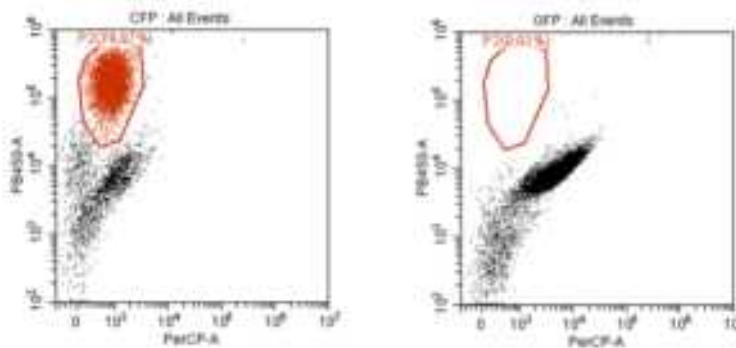
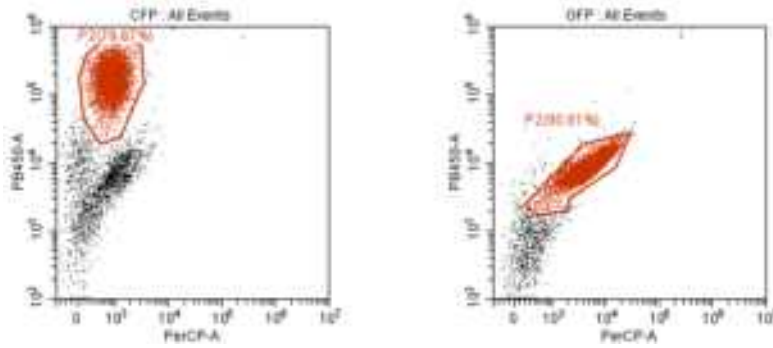


Figure 6.6 Movement - Max Setting



**Extent** — Shrinks or expands the gate around the population.

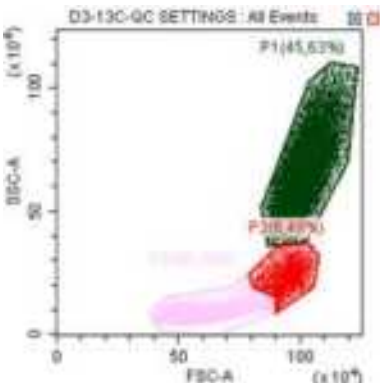
To adjust extent, right-click an autogate and drag the Extent handle in the auto gate menu left and right.

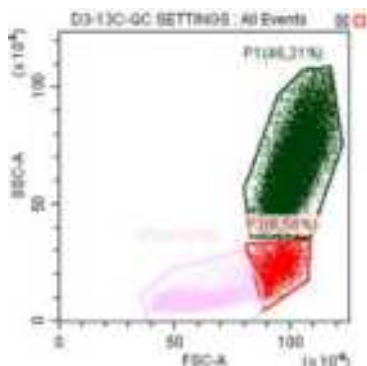


**NOTE** The default value setting for extent is 20 units. The minimum value setting for extent is 0 units and the maximum value setting for extent is 100 units.

Refer to [Figure 6.7](#) for an example of the default extent setting. Refer to [Figure 6.8](#) for an example of the maximum extent setting.

Figure 6.7 Extent - Default Setting



**Figure 6.8** Extent - Maximum Setting

## Setting Customized Parameters

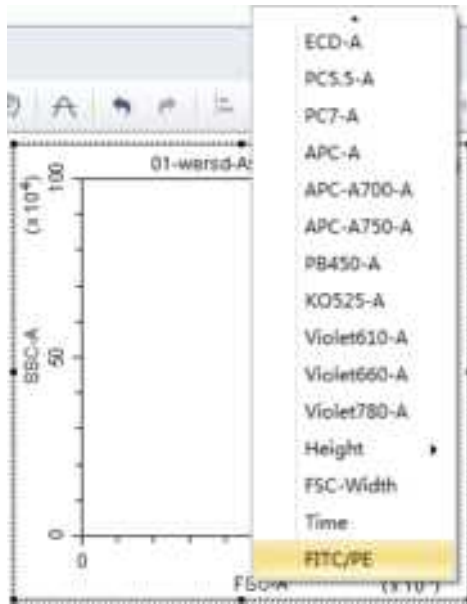
Set custom parameter to create fluorescence calculations.

- 1 Select **Set Customized Parameter** from the Settings menu. Or, right-click a test tube from the test tube menu and select **Set Customized Parameter**. The Set Customized Parameter window appears.



- 2 Enter a name for the parameter in the Name section.
- 3 Select the parameters for calculation in the Parameter dropdowns.
- 4 Select the equation operations from the Open dropdown menu.

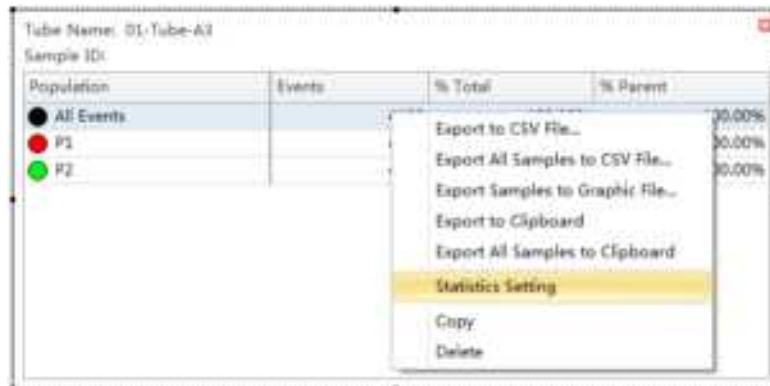
The new parameter name is displayed in the list of parameters and statistic items.



## Setting Custom Statistics

Set custom statistics to create calculations based on populations of interest.

- 1 Right-click the statistics table and select **Statistics Setting**. The Statistics Setting window appears.



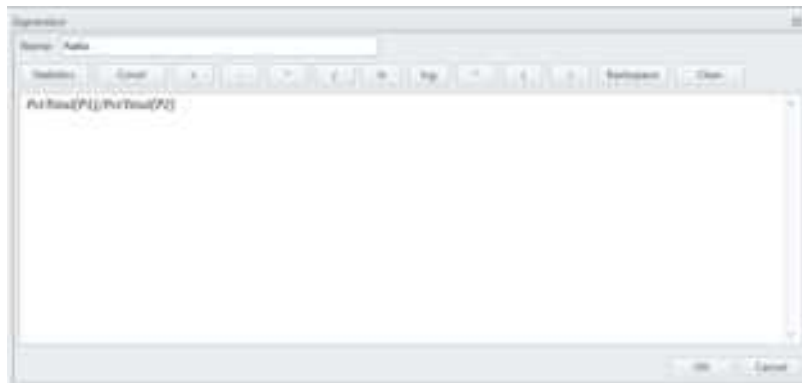
- 2 Select **Expression**.

---

**3** Select **Edit**. The Expression window appears.

---

**4** Enter the expression name in the Name section and enter the expression using the equation buttons.



5 Select **OK**.

**NOTE** The equation populates in the Statistics Setting window under the Expression selection.



Tube Name: Admin Run  
 Sample ID:  
 Ratio: 0.92

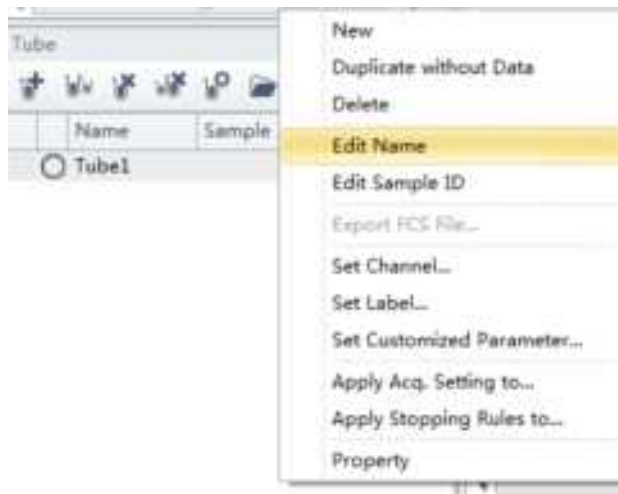
Population	Events	% Total	% Parent
All Events	7803	100.00 %	100.00 %
P1	8799	87.13 %	87.13 %
P2	7370	94.45 %	94.45 %
P3	5904	88.48 %	88.48 %

## Configuring Acquisition Settings

---

### Changing the Tube Name

To change the name of a new sample tube or the sample ID, right-click the tube name or the sample ID name in the Tube section of the screen and select **Edit Name** or simply double-click the sample tube or sample ID name.

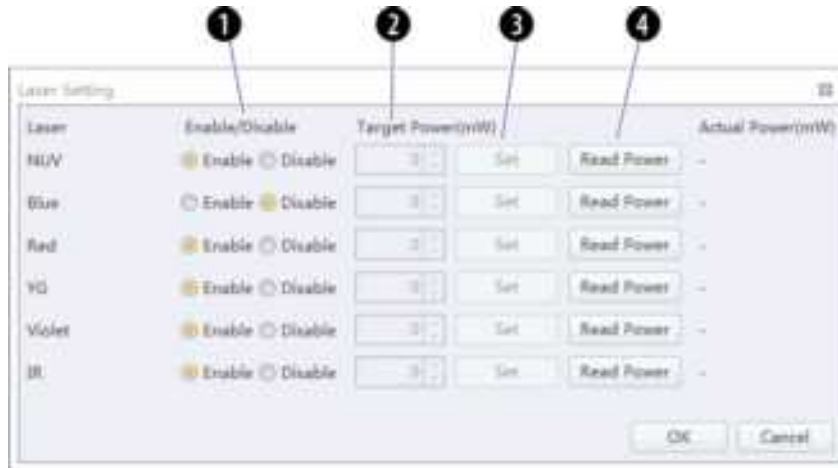


### Laser Settings

To access the Laser Setting window, select **Advanced > Laser Setting**. The Laser Setting window appears. Refer to [Figure 6.9](#).

**NOTE** The instrument must be in Standby mode to access the Laser Setting window.

Figure 6.9 Laser Setting Window [CytoFLEX LX shown]



1. **Enable/Disable:** Enables or disables the laser.
2. **Target Power (mW):** Used to change the laser target power.

**NOTE** Laser target power can only be adjusted on the CytoFLEX LX system. The power detector has  $\pm 1$  mW tolerance. Refer to [Table 6.1](#) for the target power ranges allowed in the Laser Setting screen.

**NOTE** Refer to the target powers listed for each laser in the QC reports area of the QC Report Screen (refer to [Figure 2.2](#)) for range limits.


3.  : Sets the laser target power setting.

**IMPORTANT** The Actual Power readings are +/- 1 mW.

4.  : Reads the current laser power before the flow cell assembly and displays the current laser power in the Actual Power (mW) column of the Laser Setting window. Refer to [Table 6.1](#) for a list of laser ranges.

Table 6.1 Target Power Ranges in the Laser Setting Screen

Laser	Min Power (mW)	Max Power (mW)
355	19	21
375	51	69
405	71	119
488	41	59
561	21	39
638	41	59
808	51	69

Select the **Enable** or **Disable** radio button next to each laser on the Laser Setting window to enable or disable lasers. The laser status for each laser displays in the software status bar. Hover your mouse over  to display details for each laser.



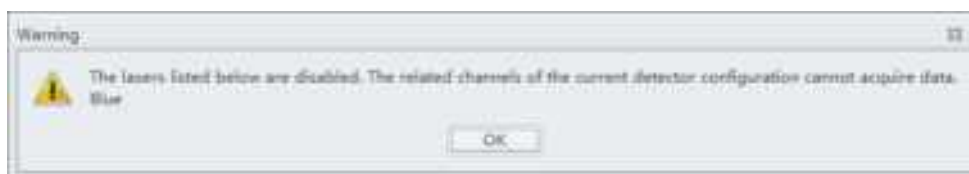
**NOTE** Lasers can only be enabled and disabled when the system is in standby mode.

### Setting Laser Target Power Settings [CytoFLEX LX Only]

**IMPORTANT** When you change the laser target power, it will impact all of your results including QC and standardization.

- 1 To access the Laser Setting window, select **Advanced > Laser Setting**. The Laser Setting window appears.
- 2 Ensure that all desired lasers are enabled.

**NOTE** If a laser is disabled on an experiment that requires that laser, the following message appears:



- 3 Select **Read Power** to view the real-time laser power reading.  
The laser power displays under the **Actual Power (mW)** column located in the far right section of the Laser Setting window.
- 4 Adjust the target power for each laser as needed.
- 5 Select **Set** to set the device power.

- 
- 6** Standardize your laser target values in the QC Experiment. Refer to [CHAPTER 5, Standardization](#).


**NOTE** Disabled lasers are marked *Laser XXX is disabled* in the QC screen and do not provide laser power values.

---

## Adjusting the Gain

While the instrument is in use, the signal value can be increased or decreased by adjusting the instrument's gain configuration.

---

- 1** Select  on the left side of the screen. The Acq. Setting window appears.
- 

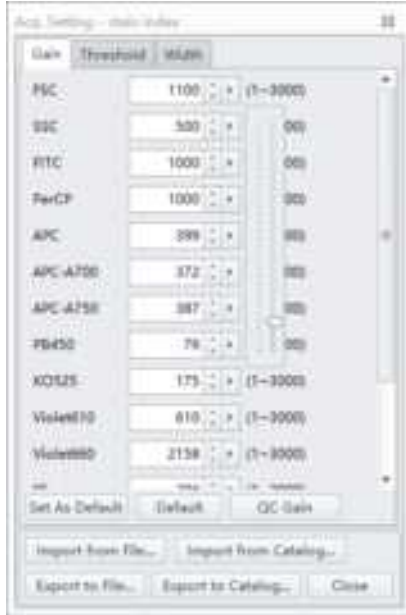
- 2** Select the **Gain** tab in the Acq. Setting window.

Select or edit the instrument's default gain settings using one of the following methods:

- Edit the gain settings and select **Set as Default** to create a new default setting.
- Select **Default** to return to your saved default settings.
- Select **QC Gain** to use the instrument's QC settings.

**NOTE** In cases where you do not specify your own default parameters, the QC settings and default settings are identical.

- Adjust the gain setting of each channel under the Gain tab in the Acq. Setting window. Raising the gain increases the signal. Lowering the gain reduces the signal.



**NOTE** Optimize the gain settings according to your own experimental goals. The QC Gain values are only for reference.

Another option is to use the **Gain Control** button  on the tool-bar in the graphic control area to adjust the gain values for cell population data to their desired levels, directly on the plots where the data appears during data collection.



**NOTE** Gain adjustments have a predefined range between 1 and 3,000.


- If necessary, change the coordinate display range and the plot type.

## Adjusting the Threshold

By adjusting the threshold, the user can remove unnecessary signal noise to ensure that most of the data collected consists of desired signal data. After the threshold settings have been configured for a given channel, the acquisition of data from this channel will only be triggered by signals that exceed the established threshold. Threshold settings have considerable bearing on whether the appropriate events can be acquired.

- 1 Create a plot to view the channels where the threshold will occur. Generally, a bivariate plot showing FSC and SSC is used.

**NOTE** Threshold can be defined for any of the fluorescence channels.

- 2 Select  on the left side of the screen.

- 3 Select the **Threshold** tab in the Acq. Setting window.



---

**4** Set the desired threshold using one of the following methods:

- Choose the channel that is used for setting the threshold. Manually enter the threshold value in the Threshold tab.

**NOTE** For dual-parameter plots, you can right-click the plot and select both parameters if desired. Then, select the desired threshold boundary for the second parameter.


- Select **Automatic** in the Primary Threshold Trigger Level section of the Acq. Setting screen to seek the target signal based on the background signal. It can quickly help find the target population if the signal-to-noise ratio (SNR) of the channel is comparatively good. The threshold can be set to either “H” (signal height) or “A” (signal area).

**NOTE** The automatic threshold value is based on the relative signal difference. When adjusting gain, you do not need to update the threshold settings. For channels with a low SNR or an excessively impure signal, manually setting the threshold parameters is recommended.

**NOTE** It is recommended to use **Manual** mode to set the threshold parameters to obtain accurate experiment data.

Moreover, “and” as well as “or” can be applied to as many as two channels, so as to allow these Boolean logical operators to be used in setting the threshold value.

- “and”: Data is displayed and collected only when two threshold conditions are met simultaneously.
- “or”: Data is displayed and collected when at least one of two threshold conditions are met.

- Select  from the plot control area. Move your mouse pointer to the desired threshold position in the desired plot and select once.

---

**5** Select **Close**.

---

## Setting Collection Conditions

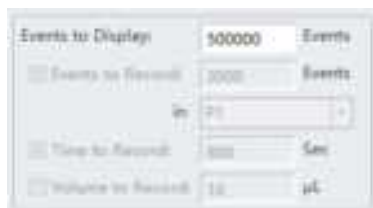
---

- 1** Check mark the conditions required to set the necessary stop count events on the left side of the Acquisition screen.

Three stop count collection conditions are available for sample recording:

- **Events to Record.** Used to set the number of events to record in the specified population.
- **Time to Record.** Used to set the collection time duration in seconds.
- **Volume to Record.** Used to set the collection volume in  $\mu\text{L}$ .

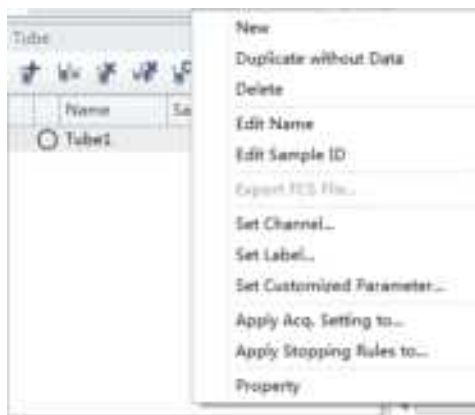
For example, if the event to record is set to record 1,000 P1 events, the software automatically stops recording when P1 events reach 1,000 events. However, the software saves all data acquired, including events outside of P1, when 1,000 P1 events is reached. You can also specify the time to store if necessary. When multiple acquisition conditions are established, any one of these conditions stops the collection process.



- 2 Select **Record** and wait for the software to complete collecting the data, at which time the sample tube holder returns to the sample loading position (see [Figure 1.12](#)).

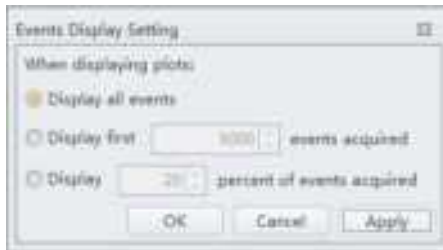


- 3 If you made changes to the data acquisition conditions and need to apply these changes to an established sample tube, right-click the sample tube and select **Apply Acq. Settings To**, to apply the conditions accordingly.



## Setting Plot Display Conditions

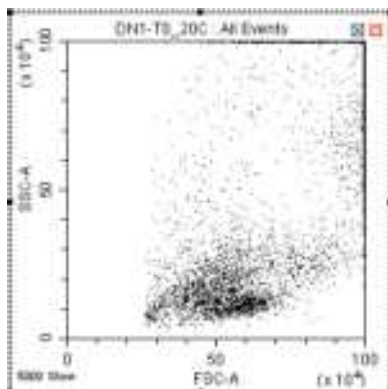
Select **Events Display Setting** in the Settings menu. The Events Display Setting window appears.



Three display options are available:

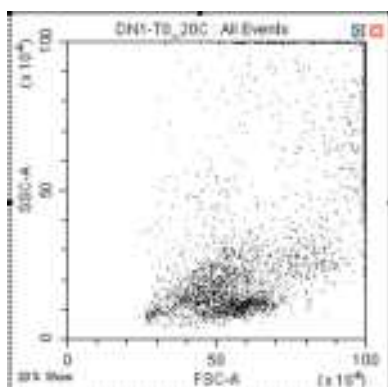
- **Display all events.** Used to view all events on the plot.
- **Display first XXXX events.** Used to set the set number of events to display.

**NOTE** The selected number of events displays in the bottom, left corner of the plot. For example, if you choose to show 5000 events, the bottom, left corner of the plot displays *5000 Show*.



- **Display XX percent of events acquired.** Used to set the percentage of events to display.

**NOTE** The selected percentage of events displays in the bottom, left corner of the plot. For example, if you choose to show 20 percent of events acquired, the bottom, left corner of the plot displays *20% Show*.



## Load Sample and Record Data

---

### Before Running Samples

 **CAUTION**

Risk of erroneous results if the Cytometer has been idle for an extended period of time. Perform a prime if the system has been idle for an extended period of time (see [CHAPTER 12, Priming the Flow Cell.](#))

- 1 Run the [Daily Startup](#) procedure.
  - 2 Run the [Instrument Quality Control and Standardization](#) procedure.
  - 3 Create an experiment. Refer to [Creating an Experiment](#).
  - 4 Verify mixer settings. Refer to [CHAPTER 12, Changing Sample Mixing and Backflush Settings](#).
  - 5 Ensure that there is sufficient space on your hard drive for sample processing and data acquisition.
  - 6 Verify the detector configuration. Refer to [Verifying, Selecting, Editing, and Creating Detector Configuration](#).
  - 7 Verify the laser settings. Refer to [CHAPTER 6, Laser Settings](#).
-

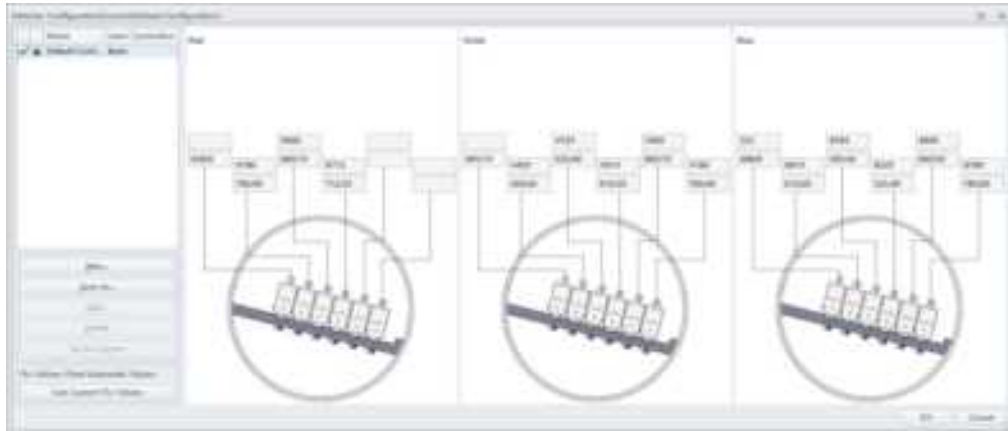
## Verifying, Selecting, Editing, and Creating Detector Configuration


### CAUTION

**Risk of erroneous results. The system will read the selected Detector Configuration even if the optical filters do not match the selected Detector Configuration. You must verify the installed optical filters match the selected Detector Configuration.**

- 1 Select **Detector Configuration** in the Cytometer menu to verify the correct detector configuration is selected. To change the configuration:
  - a. Select the desired configuration.
  - b. Select **Set as Current**.A green checkmark appears in front of the selected configuration.

[CytoFLEX Shown]



**NOTE** A configuration is locked when  appears to the left of a configuration. A configuration locks for two reasons:

- QC was run using the configuration.
- The compensation library contains data for the configuration.

Locked configurations can be deleted. Locked configurations can only be edited when the custom FLn value mode is enabled.

- 2 Select **OK** to close the Detector Configuration screen.
- 3 Proceed to Step 4 if you need to edit the Detector Configuration settings, or skip to Step 5 if you need to create a new Detector Configuration, or skip to Step 14 if you need to delete a Detector configuration. Skip to Step 7 if you need to use custom FLn value mode, or skip to Step 8 if you need to use automatic FLn value mode.

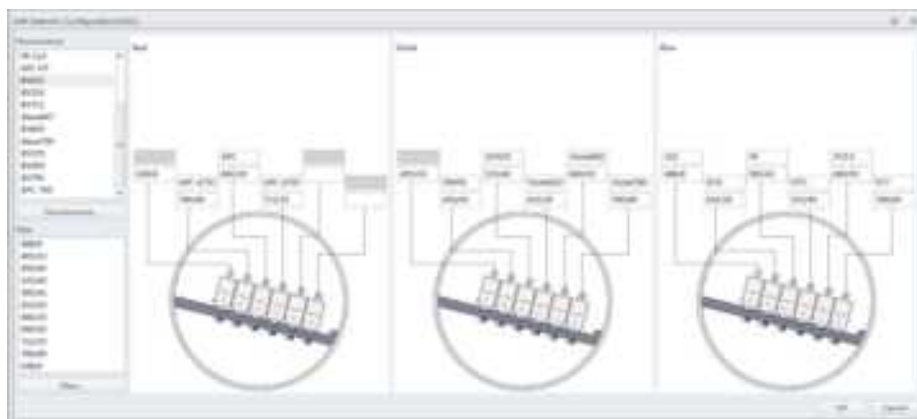
- 4 If a saved configuration requires changes, edit that configuration.

**NOTE** The factory configuration is in bold and cannot be edited.

- a. Select the configuration, then select **Edit** to access the Edit Detector Configuration screen.



- b. Channels with a white background can be edited. Drag the names of the appropriate fluorescence channels and optical filters on the left to the correct channels.

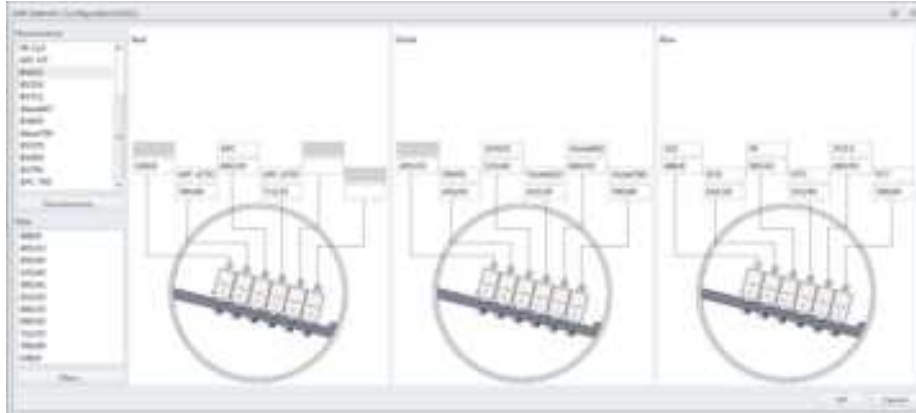


- c. Continue to Step 6.

- 5 If an appropriate configuration is not saved, create a new configuration.

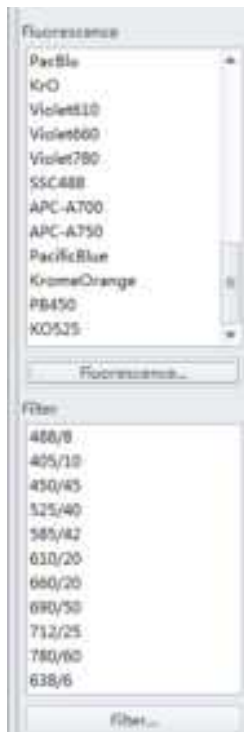
- a. Select **Detector Configuration...** in the Cytometer menu.
- b. Select **New...** and name your configuration.  
You can also select a previously saved configuration and select **Save As** to create a copy.
- c. Select **OK**.

- d. Ensure the new configuration is highlighted, then select **Edit**. The Edit Detector Configuration window appears.



- e. Customize the new configuration. Channels with a white background can be edited. Drag the names of the appropriate fluorescence channels and optical filters on the left to the correct channels.
- f. Continue to Step 6.

- 6** If a required channel name or filter is not listed on the left, select **Fluorescence** or **Filter** to add or modify the channel name or the filter.



7 To use custom FLn value mode:

- a. Select **Cytometer > Detector Configuration**. The Detector Configuration window appears.
- b. Select **Use Custom FLn Values**.



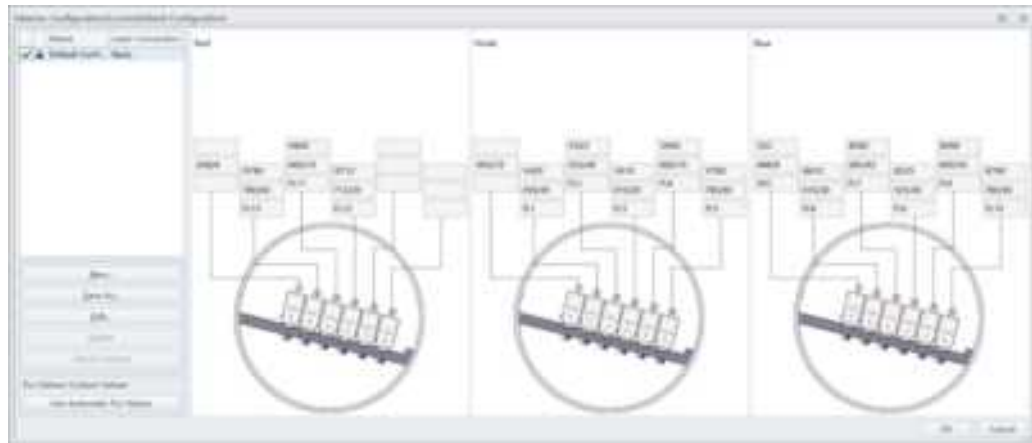
- c. Select **Yes** when the following message appears.



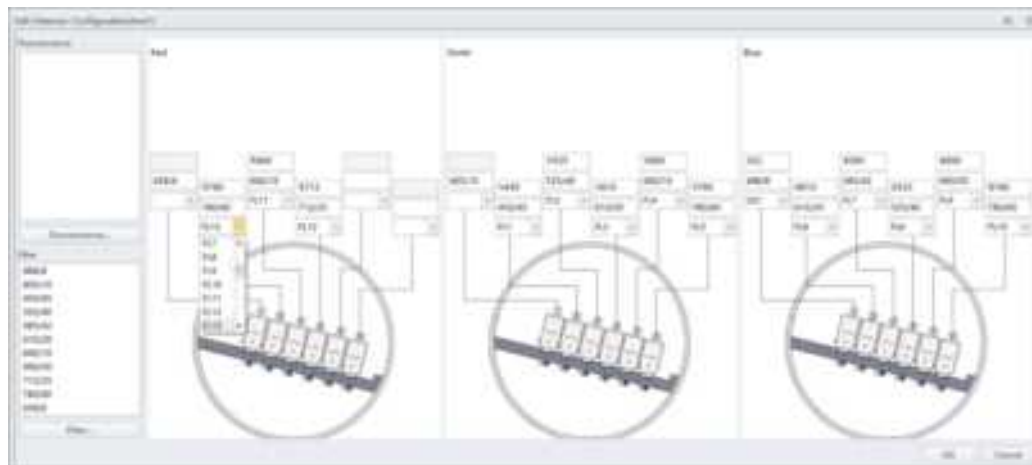
- d. Select **Yes** when the following message appears.



The custom FLn values appear for each channel.



- e. Select **Edit** to access the Edit Detector Configuration screen. And select the desired FLn value for each channel from the dropdown.



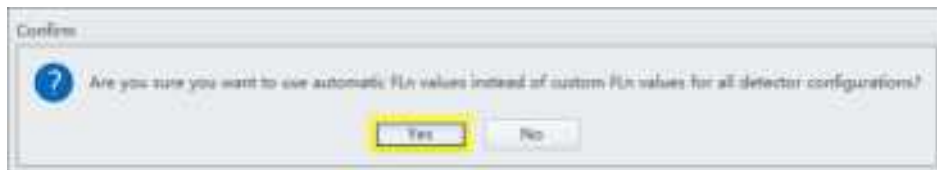
**NOTE** Fluorescence channels and optical filters can be edited as needed.

- f. Select **OK**.
- 
- 8** To use automatic FLn value mode:
- a. Select **Cytometer > Detector Configuration**. The Detector Configuration window appears.

- b. Select **Use Automatic FLn Values**.



- c. Select **Yes** when the following message appears. The Use Automatic FLn Values window appears.



- d. Select **Dynamic Automatic FLn Values** or **Fixed Automatic FLn Values** as needed.



- e. Select **OK**.

**NOTE** FLn values are not displayed in the Detect Configuration window when you use automatic FLn value mode.

---

**9** When finished, select **OK**.

---

**10** Select the appropriate configuration.

---

**11** Verify that the correct optical filters are installed in the Cytometer and match the newly created configuration.

---

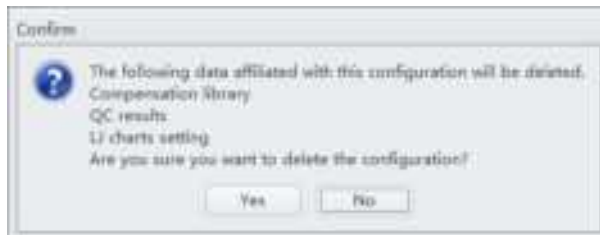
**12** Select **Set As Current**.

---

**13** Select **OK**.

---

**14** To delete a configuration created in error, select **Delete**. The following confirmation message appears. Select **OK**.



## Setting Up Violet Side Scatter (VSSC) Channel

For microparticles, a VSSC option can be added to better separate side scatter signals from noise. Beckman Coulter recommends using this channel to detect particles smaller than 500 nm.

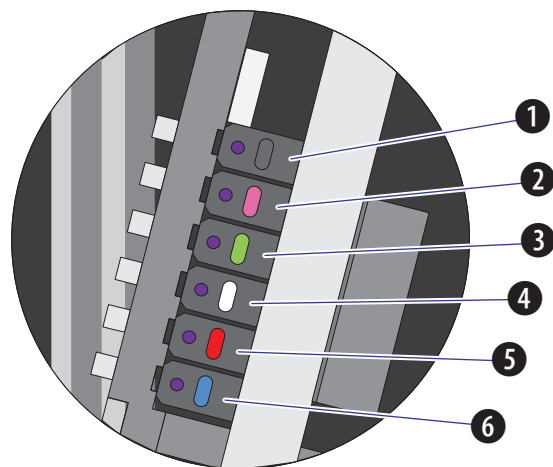
**NOTE** Since the total available channel numbers remain the same when the VSSC channel is used, the number of fluorescent channels in the violet WDM is reduced by 1 channel.

### CAUTION

**Risk of erroneous results.** Beckman Coulter recommends using the VSSC channel to detect side scatter signals for particles smaller than 0.5  $\mu\text{m}$ . VSSC could be too sensitive when large particles are being acquired. Switch back to the original detector configuration for particles larger than 5  $\mu\text{m}$ . For particles larger than 5  $\mu\text{m}$ , set the gain of the VSSC to 1 to increase the threshold and decrease the collection of sample noise.

- 1 Open the Violet WDM lid (see [CHAPTER 12, Replacing the Optical Filter](#)) and remove the 405 nm filter, the 450 nm filter, and a third filter not required for the test, for example, the 780 nm filter.

**NOTE** Refer to [Table 6.1](#) to identify the WDM filter mount color codes.

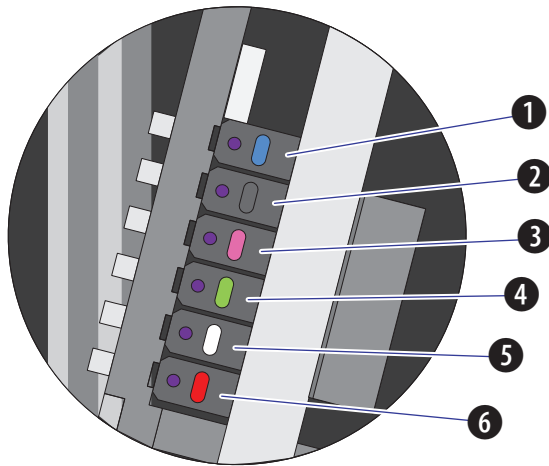


- |               |               |
|---------------|---------------|
| 1. Position 1 | 4. Position 4 |
| 2. Position 2 | 5. Position 5 |
| 3. Position 3 | 6. Position 6 |

**NOTE** The orientation for position 1 through 6 starts with position 1 located closest to the fiber coming into the WDM, and position 6 located on the side furthest from the fiber coming into the WDM.

- 2 Place the third filter in position 1, the 405 nm filter in position 2, and the 450 nm filter in position 3.

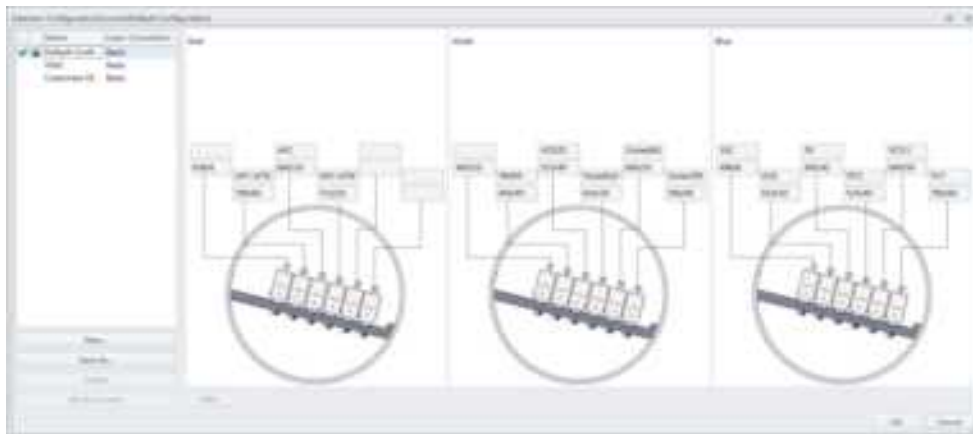
**NOTE** For the Violet WDM, Beckman Coulter recommends placing the filters in sequential order from the shortest wavelength to the longest wavelength in positions 2 to 6. Position 1 will always contain the unused filter.



- |               |               |
|---------------|---------------|
| 1. Position 1 | 4. Position 4 |
| 2. Position 2 | 5. Position 5 |
| 3. Position 3 | 6. Position 6 |

- 3 Start the CytExpert software. Refer to [CHAPTER 4, Logging into the Software](#).

- 4 Select **Detector Configuration** from the Cytometer menu. The Detector Configuration window appears.

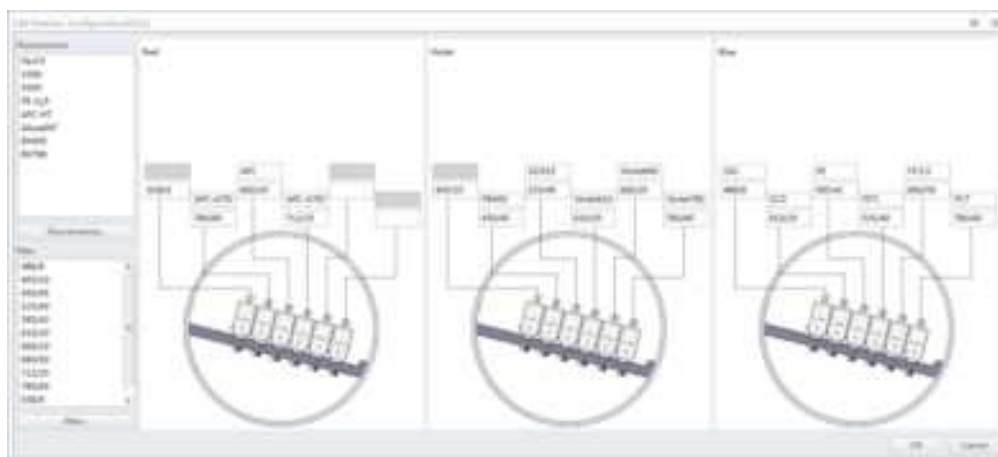


- 
- 5 Select the Default Configuration and select **Save As**. The Configuration Save As window appears.



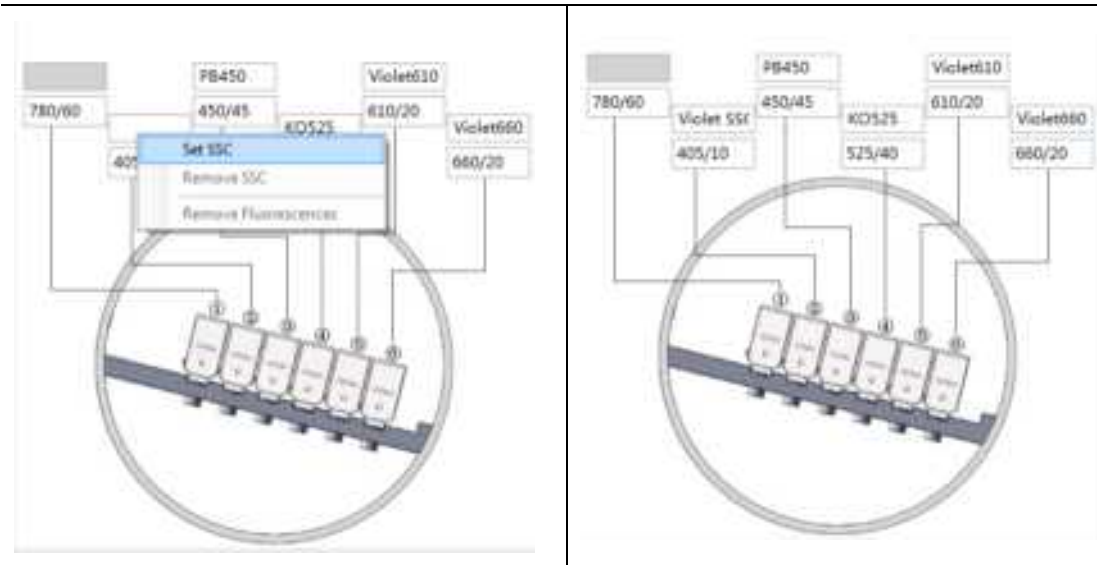
- 
- 6 Name the new configuration VSSC and select **OK**.

- 
- 7 Select the VSSC configuration and select **Edit**. The Edit Detector Configuration window appears.



- 
- 8 Change the filters and channel names according to the filter order in the violet WDM.

- 9 Right-click the VSSC channel, and select **Set SSC** to set it as the Violet SSC channel.




- 10 Select **OK** to save the changes and close the Edit Detector Configuration window.
- 11 Select **Set as Current**.
- 12 Select **OK** to save the changes and close the Detector Configuration window.
- 13 Create a new experiment using the VSSC configuration. Refer to [Creating an Experiment](#).

## Sampling and Collecting Data [Without Plate Loader]



**NOTE** Settings can be imported from the Acquisition Settings Catalog. Refer to [Importing and Exporting Instrument Settings](#).

If compensation settings are desired, import the compensation from the Compensation Library or import the compensation file. Refer to [CHAPTER 7, Importing and Exporting Compensation](#).

- 1 Select  from the Test Tube screen to create the new sample tube.

**NOTE** The first sample tube is already created by default.

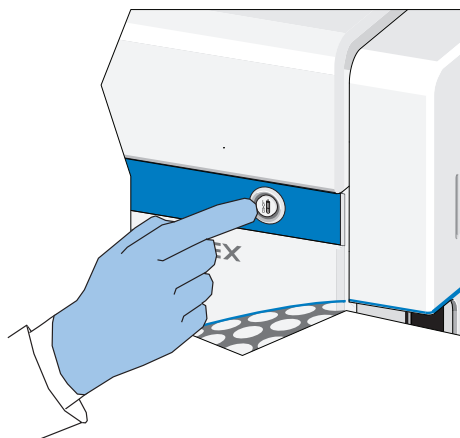
- 2 Change the tube name if necessary. Refer to [Changing the Tube Name](#).
- 3 Mix the sample tube intended for testing.
- 4 Ensure that the sample tube holder is in the sample loading position (see [Figure 1.12](#)). If the sample tube holder is not in the sample loading position, select **Initialize**.

**WARNING**

**Risk of biohazardous contamination. When using 1.5-mL and/or 2-mL sample tubes, always cut the cap off and do not exceed 300- $\mu$ L sample volume. Running samples with a cap attached to the sample tube or with volumes exceeding 300- $\mu$ L can result in sample splashing.**


- 5 Place the sample tube in the sample tube holder.
- 6 Select the desired acquisition parameters (Events/Time to Record/Volume to Record and Sample Flow Rate) on the left side of the screen.

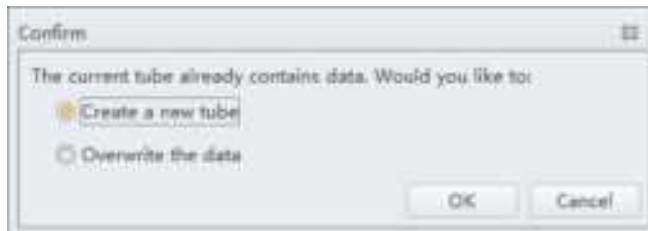
**NOTE** You can also push the load button on the front of the instrument to automatically start the run and record the data.



---

7 Select **Run** to load the sample.

**NOTE** When you select a tube that only contains acquired data, as indicated by the blue tube  in the test tube section of the screen, the following message appears:



- **Create new tube.** Saves the current tube and creates an additional tube.
- **Overwrite the data.** Overwrites the current tube data with new data.

---

8 View the plots and establish the gates. Refer to [Creating Plots and Gates](#). Adjust the gate and instrument settings as necessary. Refer to [Configuring Acquisition Settings](#).

---

9 Adjust the gain settings. Refer to [Adjusting the Gain](#).

---

10 Adjust the threshold settings. Refer to [Adjusting the Threshold](#).


---

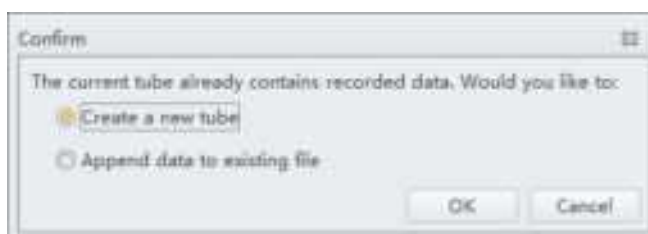
11 Adjust the Acquisition conditions. Refer to [Setting Collection Conditions](#).

---

12 Select **Record** to save the data.


Wait for the saving process to finish. The sample tube holder returns to the sample loading position (see [Figure 1.12](#)).

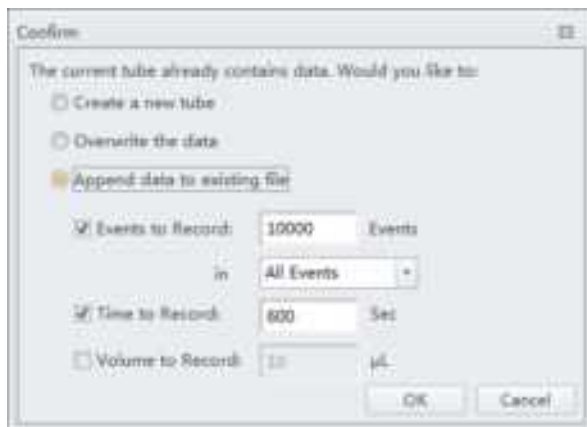
**NOTE** When you select a tube that contains recorded data, as indicated by the green tube  in the test tube section of the screen, the following message appears:



- **Create a new tube.** Creates a new tube in the test tube section of the screen for the data.

- **Append data to existing file.** Adds new data to the existing data.

**NOTE** When you select a tube that only contains acquired data, as indicated by the blue tube  in the test tube section of the screen, the following message appears:



- **Create a new tube.** Creates a new tube in the test tube section of the screen for the data.
- **Overwrite the data.** Overwrites the current tube data with new data.
- **Append data to existing file.** Adds new data to the existing data.

**13** Repeat Steps 1-12 until all sample tube data required for testing has been collected.

**NOTE** If the rate suddenly appears to drop, check to see if the sample has run dry or the sample probe is clogged. Any time the sample probe becomes clogged, immediately select **Stop** to unload the sample. Then select **Backflush** to clean the sample probe. Refer to [CHAPTER 11, Daily Clean](#) to flush out the sample probe. If you are still unable to clear the sample probe, [contact us](#).

## Sampling and Collecting Data [With Plate Loader]

**IMPORTANT** Ensure the sample plate is loaded properly before acquiring the samples.


- 1** To run a single well:
  - a.** Select the well in the Plate window.
  - b.** Select **Run** to prompt the system to begin sample aspiration.

**NOTE** Acquisition settings can be adjusted during acquisition.

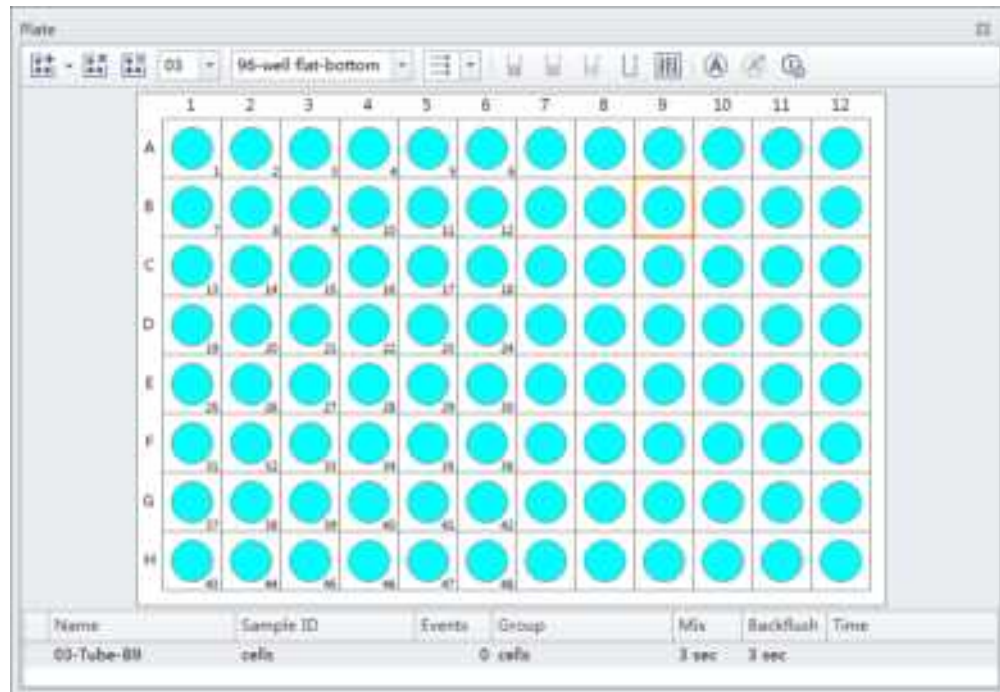
- c.** Select **Record** to save the data.
- d.** Select **Eject** to prompt the plate loader to eject.


To run a set of wells:

- a.** Select the desired wells.


- b. Select  or right-click and select **Auto Record** to set the selected wells for auto record. Number labels appear in the bottom right corner of each well set for auto record. Sample acquisition occurs in the order indicated by the numbers.

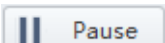
[CytoFLEX LX Shown]



**NOTE** Select  to remove the auto record setting from the selected wells.

- 2 Select  to begin sample acquisition.

**NOTE** Select  to skip the current well and move to the next well for acquisition.

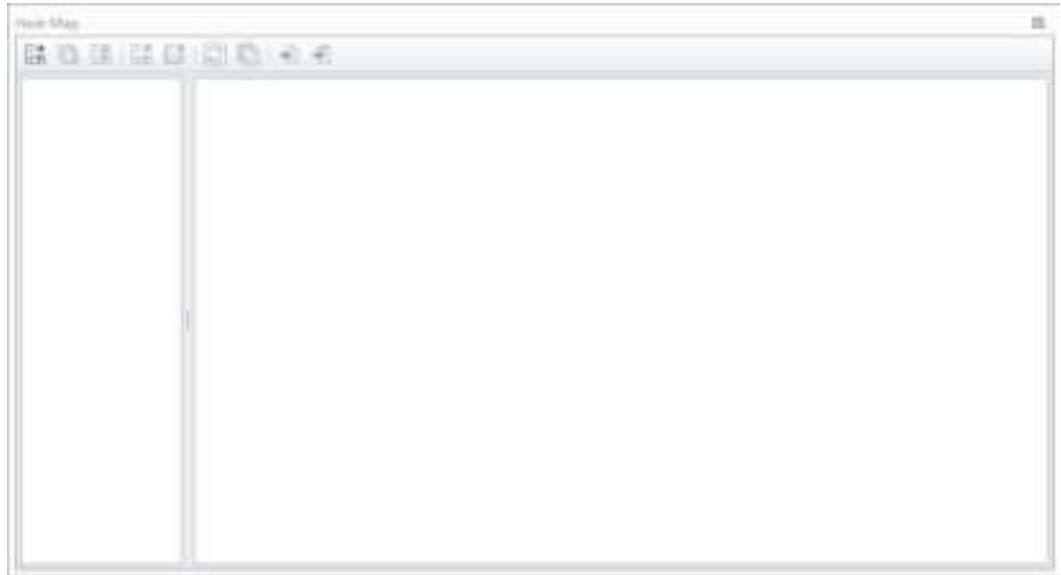
**NOTE** Select  to pause acquisition. The software completes the current sample well acquisition and pauses when the current well is complete. The plate can be loaded and unloaded while the sample acquisition is paused.


**NOTE** Select  to continue the acquisition.

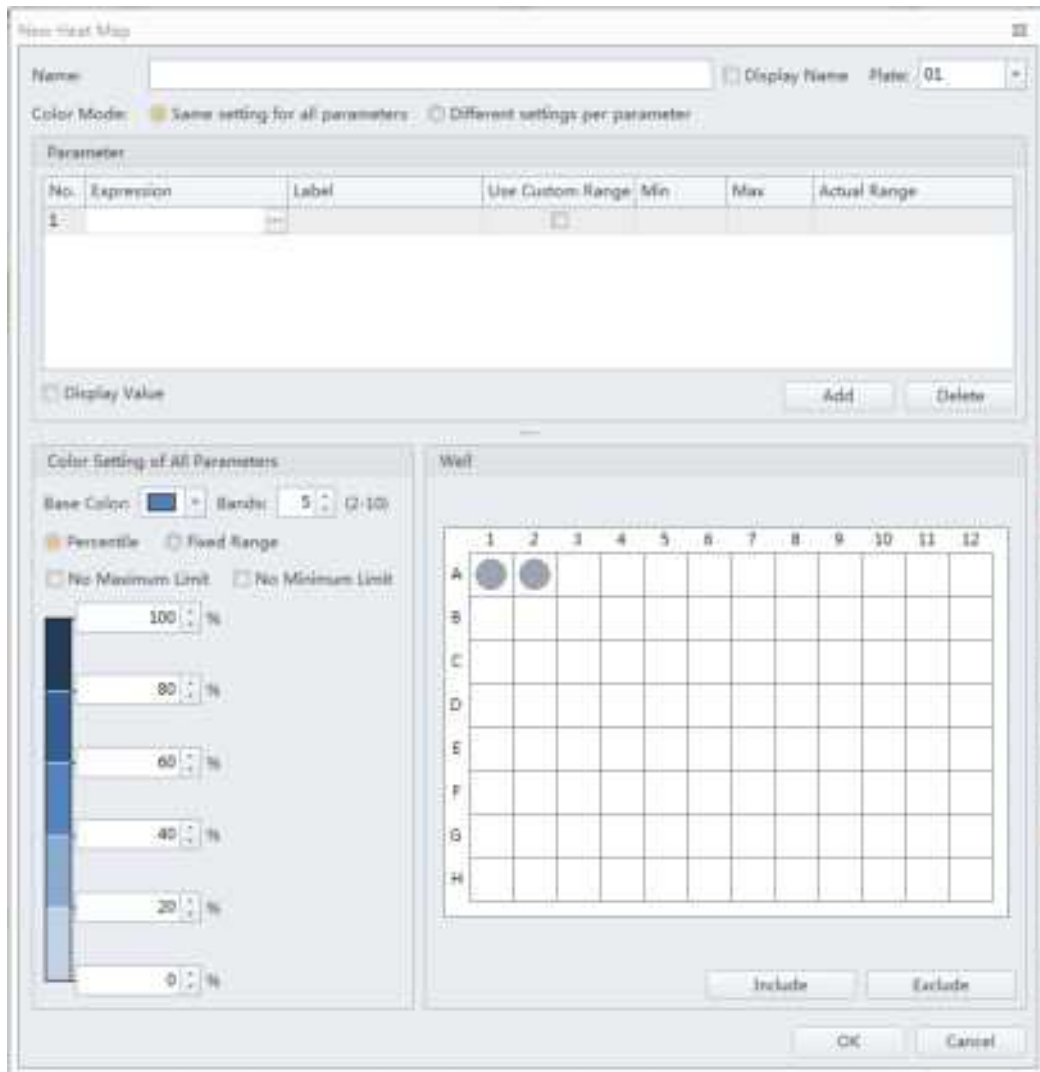
## Creating a Heat Map [with Plate Loader]

**IMPORTANT** The heat map function is only available in plate mode.

- 1 Select  from the Tube management controls (refer to [CHAPTER 2, Test Tubes](#)). The Heat Map window appears.



- 2 Select  from the Heat Map window. The New Heat Map window appears.



**NOTE** You must have at least one plate that contains data in at least two wells to create a new heat map.

**NOTE** Select **Display Value** to display the value within the heat map well on the Heat Map window. Display Value is only selectable when using a single parameter.

- 3 Enter the heat map name, select the Display Name checkbox if you want the name to display in the heat map view, and select the heat map data set from the Plate drop down menu.




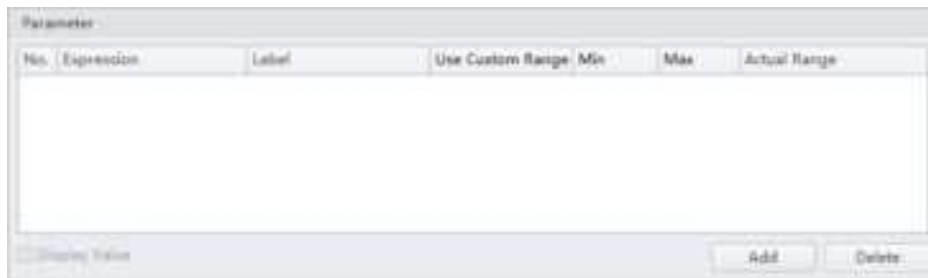
**NOTE** The plate drop down menu only displays plates that contain data.

4 Select the desired color mode.



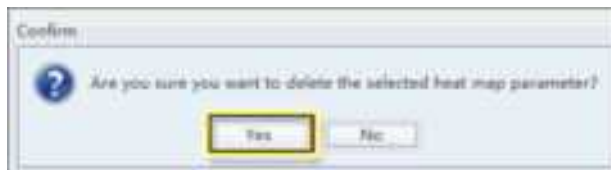
**NOTE** Select **Same setting for all parameters** to use the same color for all parameters.  
Select **Different settings per parameter** to use different colors for different parameters.

5 Select  to add a parameter item to the Parameter section of the New Heat Map window.

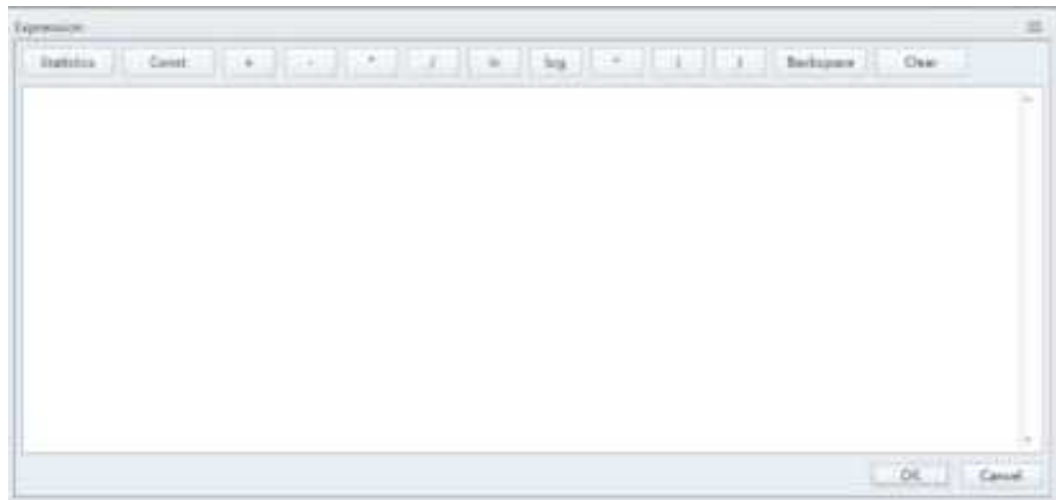


**NOTE** A maximum of 6 parameters can be added to a single heat map.

**NOTE** Select a parameter then select  to delete a parameter. Select **Yes** when the following message appears.



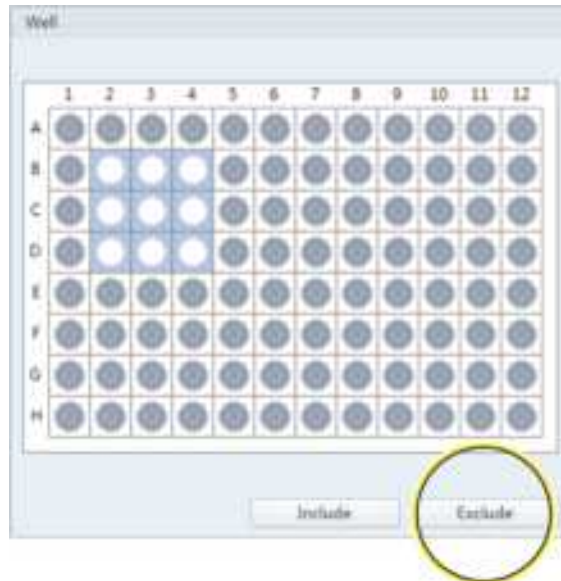
- 6 Change the Parameter elements in the Parameter section of the New Heat Map window.
  - a. Change the Label name if needed.
  - b. Select  from the Statistic Expression section of the Parameter list. The Expression window appears.



- c. Enter the desired expression for the selected parameter then select **OK**. The Actual Range displays in the Parameter section of the Heat Map window.
    - d. Select the **Use Custom Ranges** checkbox if needed and enter the Min and Max ranges.

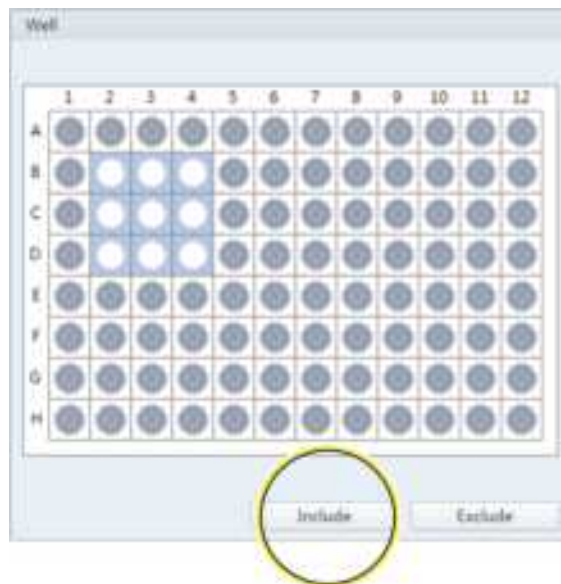
**NOTE** The Actual Range displays when the statistics parameter can be calculated.

- 7 Select any wells that should be excluded from the heat map in the Wells section of the New Heat Map window then select  .

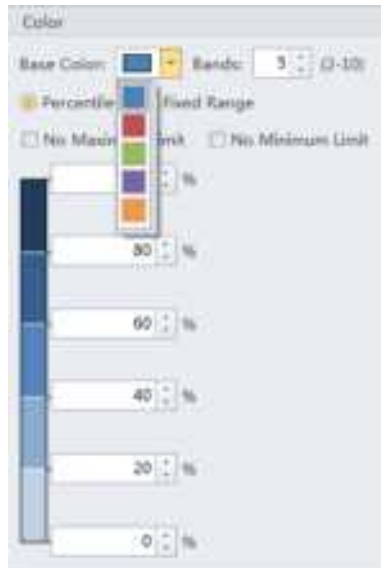


**NOTE**  designates that a well is included. All wells are included by default.

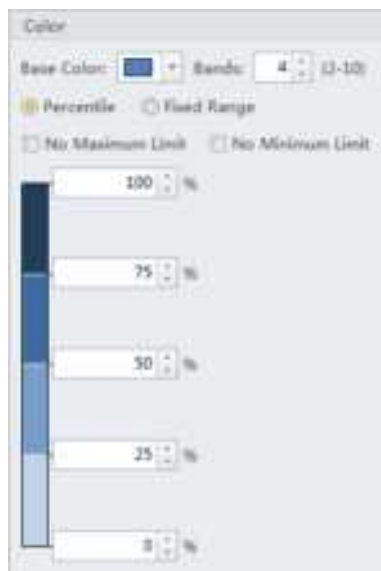
**NOTE**  designates that a well is excluded. Select any wells that should be included and select  .



- 8 Edit the color elements in the Color section of the New Heat Map window.
- Select a color from the base color drop down menu.



- Select the number of color bands desired from the Bands drop down menu. The window refreshes to display the appropriate number of bands.



**NOTE** You can choose between 2 and 10 color bands.

- Select **Percentile** to assign colors based on a percentage range.

**NOTE** If **Use Custom Range** is selected, the percentile is calculated according to "Min" and "Max".  
If **Use Custom Range** is not selected, the percentile is calculated according to "Actual Range".

Or

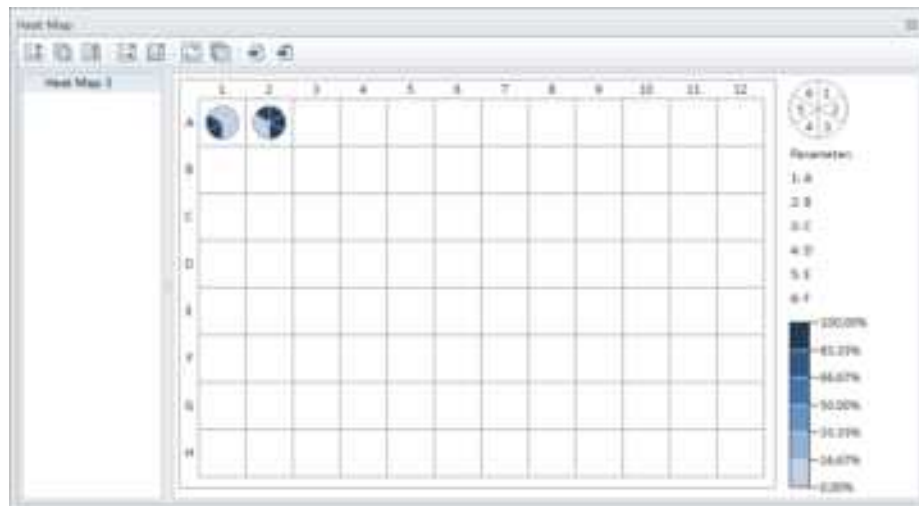
Select **Fixed Range** to assign colors based on a fixed range specified by the user. The heat map is created directly based on the result of the expression. The color of the heat map displays according to the legend range.

**NOTE** Fixed Range can only be used with one parameter.

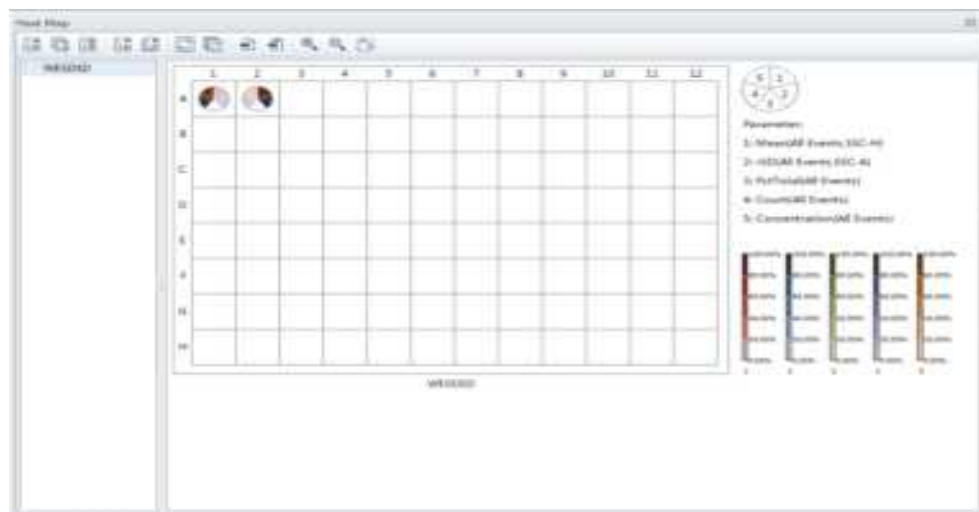
**NOTE** If **Different settings per parameter** is selected, repeat Steps a-c to assign the color setting to each parameter.

9 Select **OK**. The New Heat Map window closes to display the Heat Map window.

**Heat Map with 6 Parameters [Same setting for all parameters]**

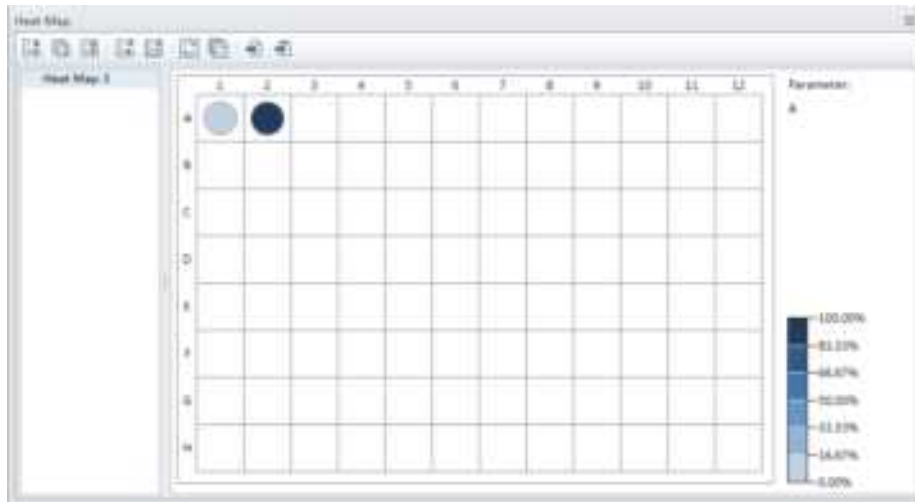


**Heat Map with 6 Parameters [Different settings per parameter]**




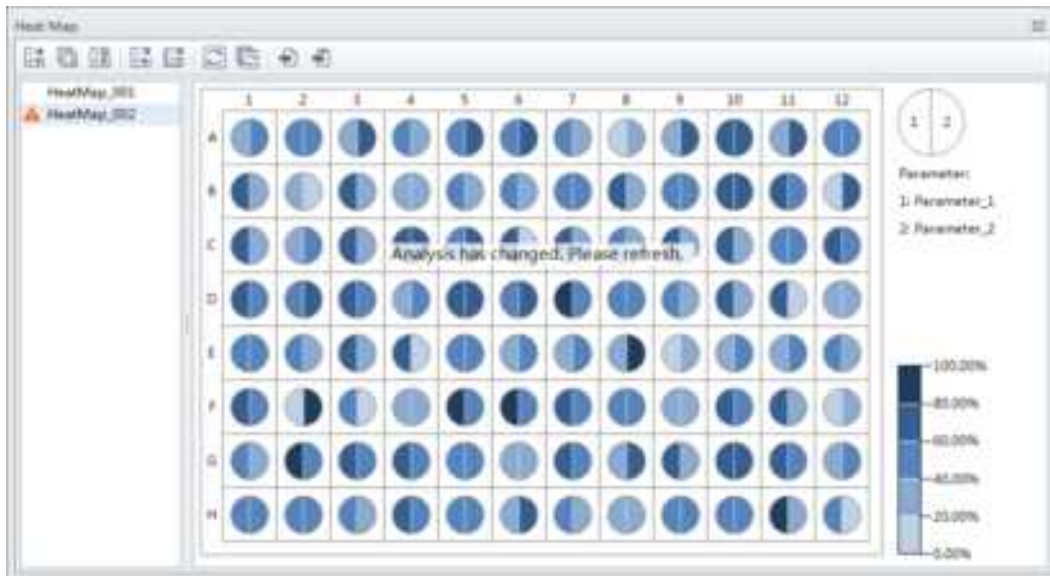
**NOTE** When viewing more than one parameter, the parameter location relative to the pie chart is visible in the top, right corner of the Heat Map screen.


### Heat Map with 1 Parameter




### Refreshing a Heat Map

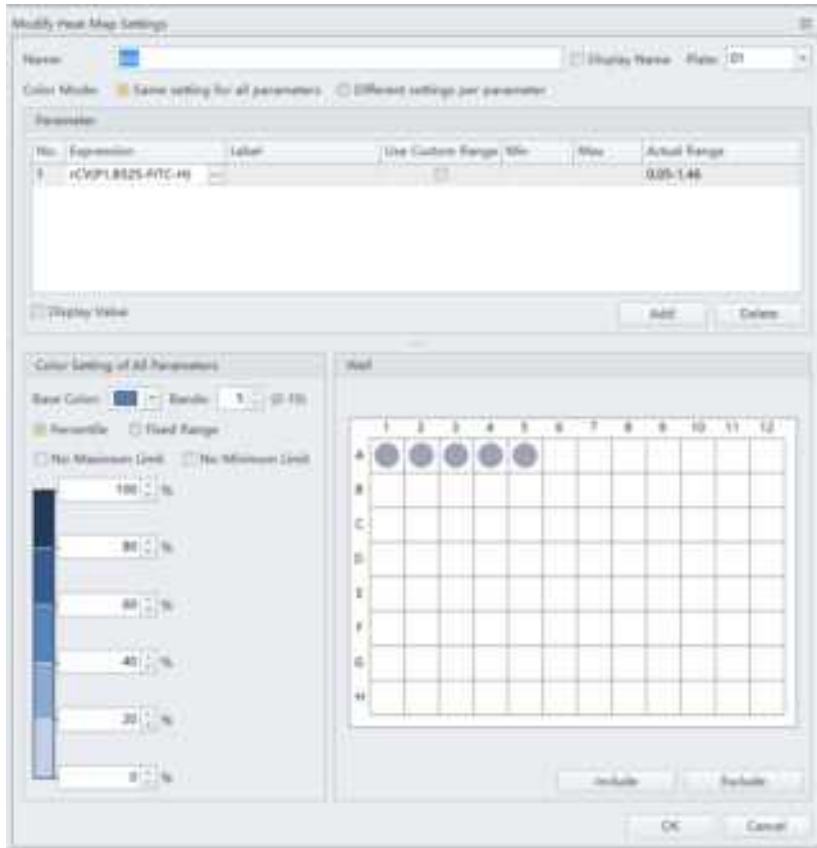
When data displayed in a heat map is no longer current, the  symbol appears next to the heat map name and the message *Analysis has changed. Please refresh.* appears on the Heat Map window.




Select  from the heat map toolbar to refresh the analysis.


## Modifying Existing Heat Map Settings

Select  from the heat map toolbar to modify existing heat map settings. The Modify Heat Map Settings window appears.



### Deleting an Existing Heat Map

To delete a single heat map, select the heat map to be deleted from the list of heat maps in the Heat Map window then select  from the heat map tool-bar.

To delete multiple heat maps, select  from the heat map toolbar. The Delete Multiple Heat Maps window appears.





Select the heat maps to be deleted then select **OK**.

**NOTE** The Select All checkbox allows you to delete all of the heat maps listed.

### Exporting a Heat Map

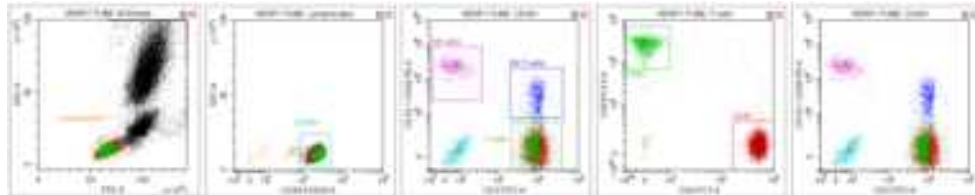
Heat maps can be exported as a graphics file (.bmp or .emf) or to a clipboard (.bmp).

To export a heat map as a graphics file, select  from the heat map toolbar.


To export a heat map to a clipboard, select  from the heat map toolbar.

## Analyzing and Exporting Data

- 1 Select the sample tube to be analyzed.
- 2 Establish new gates or adjust the position of existing gates. Refer to [Creating Plots and Gates](#).

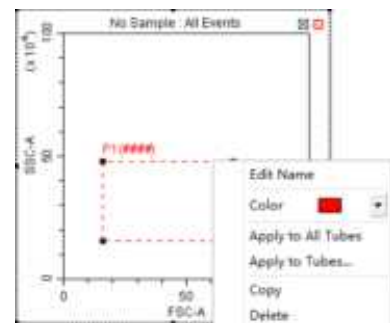


**NOTE** Changing a gate's position does not affect the positions of other gates already established on a given sample tube. Each test tube individually records the positions of its associated gates. If you need to make a change that concerns all the tubes, you must select the gate, then right-click the correctly positioned gate and select **Apply to All Tubes**.

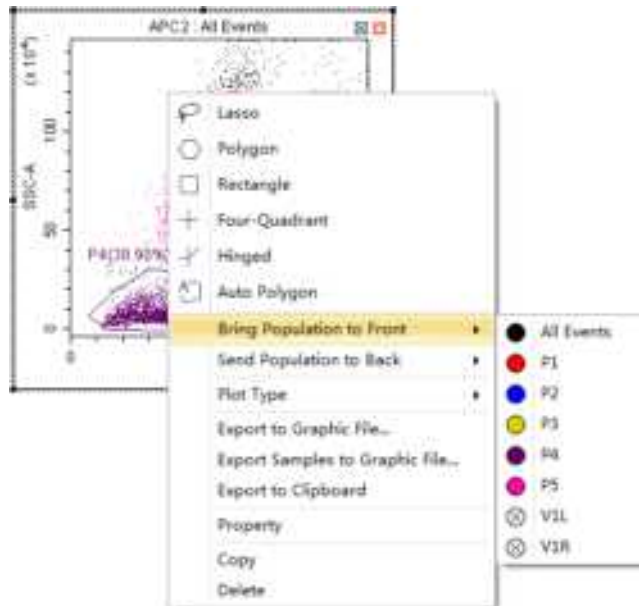
- 3 Select . The Gate Hierarchy screen appears.
- 4 Check the relationship between the parent and daughter gates in the Gate Hierarchy window.


**NOTE** Newly added gates become subsets of populations displayed in plots with existing gates. Name and display color can be modified. Right-click directly on a gate plot to change the name and color.

**NOTE** Select **No Color** to leave the gated events uncolored while retaining the color of the parent populations. By default, the populations defined by a vertical gate, hinged gate, or four-quadrant gate are uncolored.

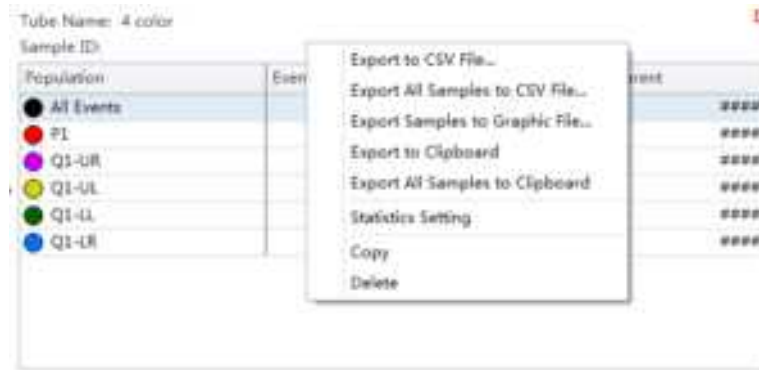


- 5 Right-click the plot and select **Bring population to front** to make the display color of the specified gate appear in front of all other colors, or select **Send population to back** to hide the display color of the specified gate behind all other colors.



- 6 Select  in the plot area to generate a statistical table.

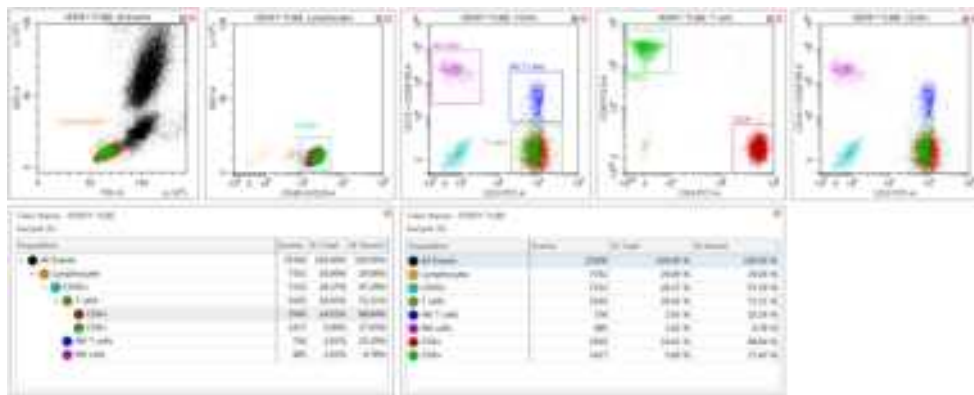
- 7 Right-click the table and select **Statistics Setting** to modify the settings of the statistics display parameters. The Statistics Setting window appears.



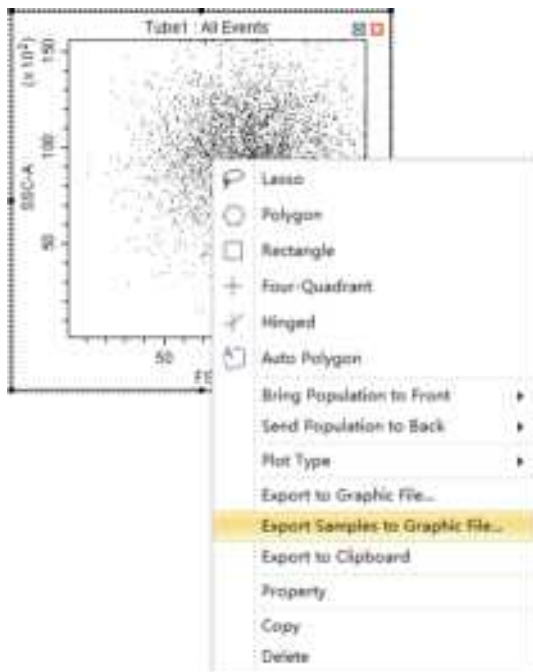
The Statistics Setting window allows you to change the display of the header, statistical elements and cell populations included.



The final generated plots appear as below.



- 8 Right-click a plot and select **Export to Clipboard** or **Export to Graphic File** from the drop-down menu to select an image to export.



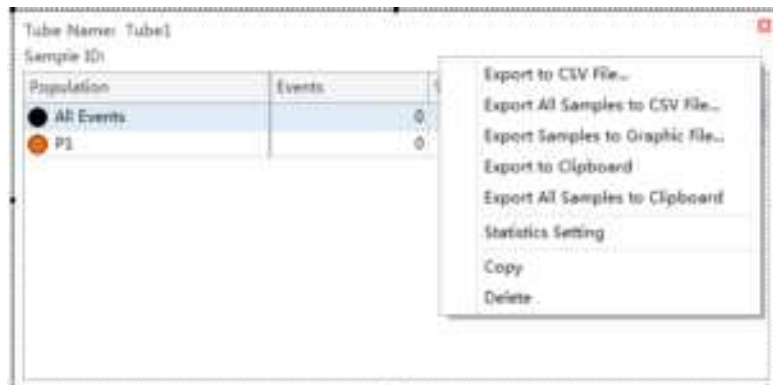
- **Export to Clipboard** copies the plot to the clipboard, allowing you to paste it directly into documents in common file formats.

**NOTE** Multiple plots can only be copied and pasted into Microsoft Word. If a single plot is copied, this can be pasted into both Microsoft Word or Microsoft PowerPoint.

- **Export to Graphic File** saves the plot as an image file.

**NOTE** **Export to Graphic File** can export plots in two selectable file formats. BMP bitmap format and EMF vector format.

- 9 To export statistics, right-click a statistical table to select any one of the available export options.



- **Export to CSV File** exports individual tube statistics as a single CSV file.
- **Export All Samples to CSV File** exports all tube statistics as a single CSV file.
- **Export to Clipboard** copies the statistics of an individual sample to the clipboard, allowing you to paste them directly into a Microsoft Excel file or other file formats.
- **Export All Samples to Clipboard** assembles the statistics for all the sample tubes of an experiment and copies them together to the clipboard. From there they can be pasted as a group into a Microsoft Excel file or other file formats.
- **Copy** converts a statistical table into an image format that can be pasted into documents.

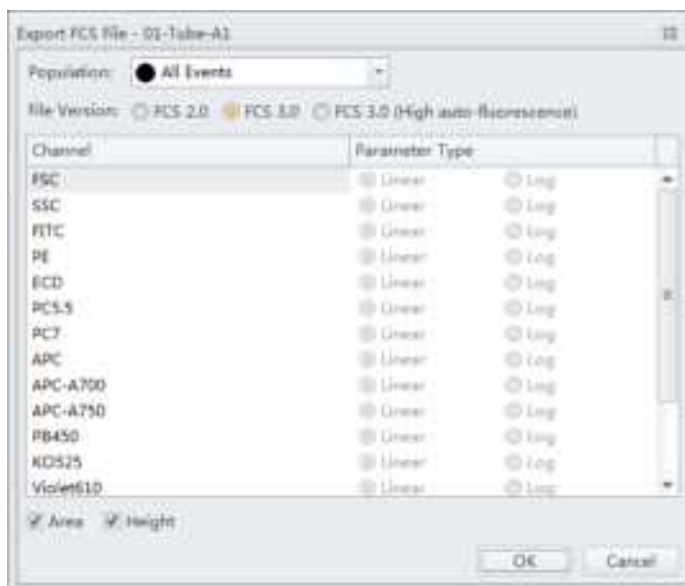
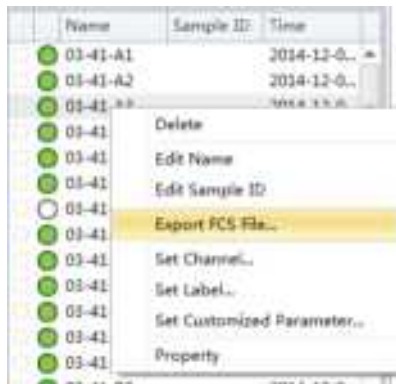
- 10 Export the FCS file if necessary. Refer to [Exporting FCS Files](#).

**NOTE** Ensure that any storage devices used with the instrument are free from viruses. To guard against data loss, Beckman Coulter recommends backing up data on a frequent and regular basis. Beckman Coulter is not liable for any loss of data resulting from computer viruses or damage to hardware.

## Exporting FCS Files

### Exporting Single Tube Files

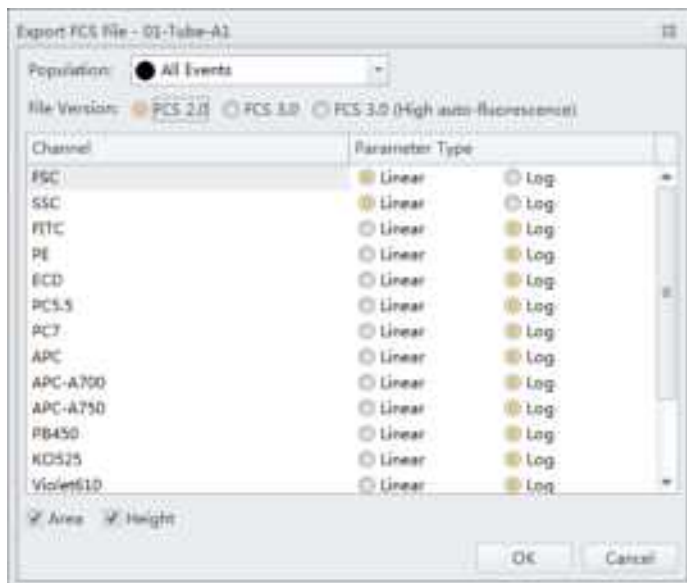
- 1 Right-click the desired tube from the test tube section of the screen and select **Export FCS File**. The Export FCS File window appears.



- 2 Select the population from the Population dropdown menu.
- 3 Select either **Area** or **Height**.

- 
- 4 Select the FCS format next to File Version.

**NOTE** The default setting is FCS 3.0. If FCS 2.0 is selected, select the parameter type (linear or log) from the parameter type section of the window.



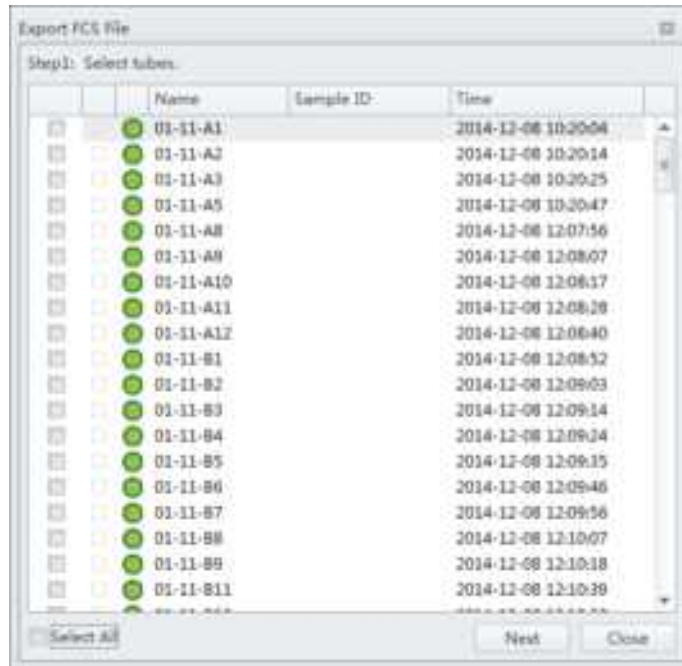
**NOTE** The default CytExpert FCS file contains high auto-fluorescence vector values that may not be recognized by third party software. Therefore, the data displays differently in third party software packages than in CytExpert. Auto-fluorescence values are added for the FCS 3.0 (High auto-fluorescence) export option to accommodate the use of third party software. Since both FCS 3.0 options have the same .fcs file extension, ensure that you save the FCS 3.0 (High auto-fluorescence) files to a different folder than the FCS 3.0 files.

- 
- 5 Select the path to save the FCS file to from the Path section of the window.

- 
- 6 Select **Next** to export the file.
-

## Exporting Multiple FCS Files

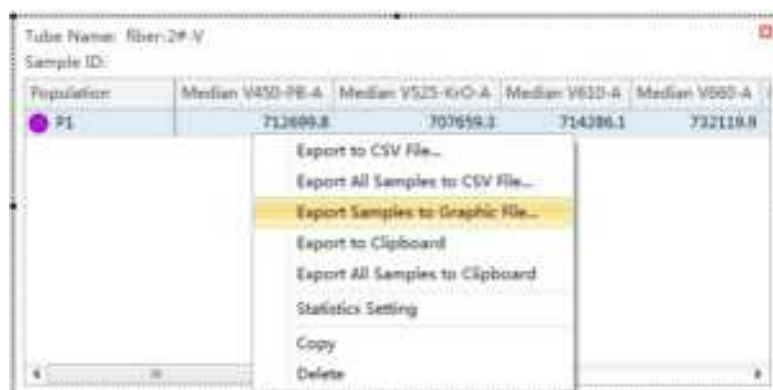
- 1 Select **Export FCS File** from the File menu. The Export FCS File window appears.



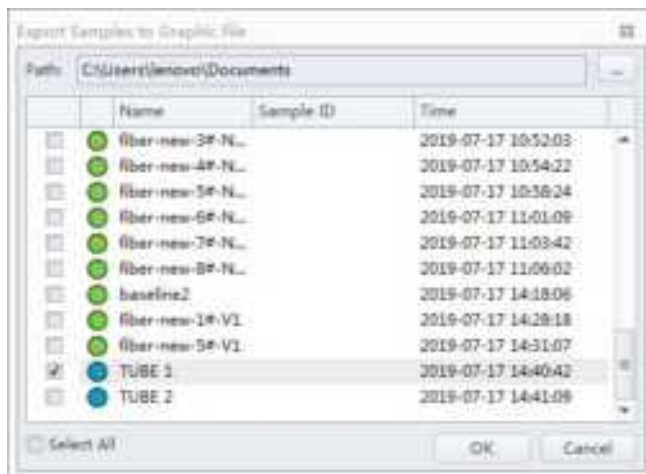
- 2 Select the tubes to export.
- 3 Repeat Steps 2-6 from [Exporting Single Tube Files](#).

## Exporting Plots or the Statistics Table of Multiple Tubes as Picture Files

- 1 Right-click on the plot or statistics to export.



- 2 Select **Export All Samples to Graphic File**. The Export Tubes to Graphic Files window appears.



- 3 Select the desired tubes to export.


- 4 Select the path.

- 5 Select **OK**.


**NOTE** The plots of the selected tubes save as .bmp file.

## Importing and Exporting Instrument Settings

The CytExpert software supports importing and exporting instrument settings to facilitate the experiment process. Only instrument settings identical to the current configuration can be imported with current detector settings.

Select  to edit gain, threshold, and width. These can be imported from an experiment file or from a catalog of instrument settings.

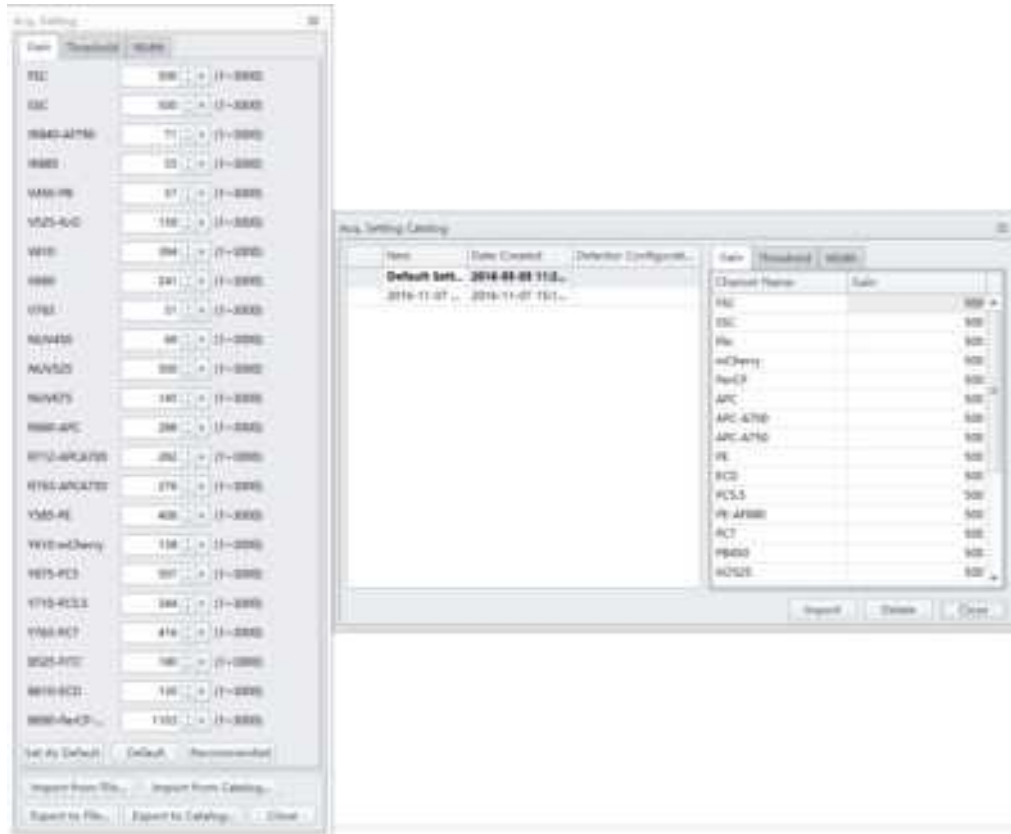
### Importing Instrument Settings

- 1 Select the desired sample tube to import. Then select .

**NOTE** Instrument settings can only be imported into tubes where data has not yet been recorded.


- 2 Select **Import From File**, locate the file with the required instrument settings, or select **Import From Catalog** to import the instrument settings.

[CytoFLEX LX Shown]



- 3 Select **Close**.

### Exporting Instrument Settings


- 1 Select the desired sample tube to export. Then select .
- 2 Select **Export To File** to export a current set of instrument settings, stored in a file ending in .acq.  
Or  
Select **Export To Catalog**, give a name to the settings to be exported, and export the file to the software's Acquisition Setting Catalog, then select **OK**.
- 3 Select **Close**.

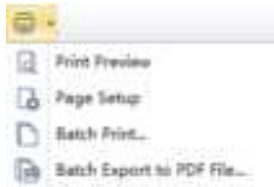
## Importing and Exporting Compensation Settings


The software supports unrestricted importing and exporting of compensation data, regardless of whether the sample tube data has already been acquired. Imported compensation values only cover channels identical with the current instrument configuration. The software automatically adjusts compensation values according to differences in the gain level. Refer to [CHAPTER 7, Importing and Exporting Compensation](#).

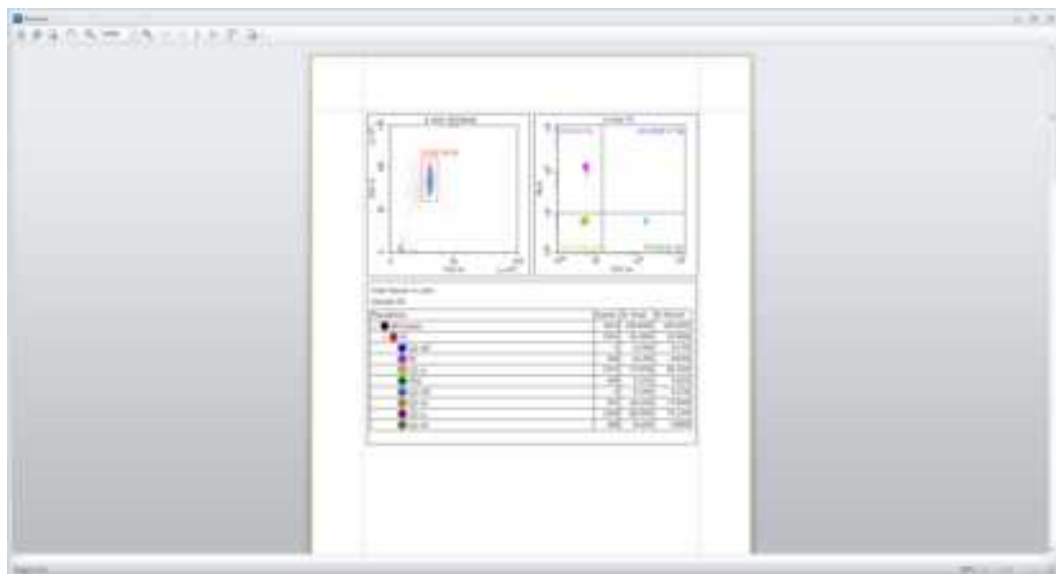
## Printing Graphics


CytExpert offers printing functionality for the plots and tables that appear in the plot area. The software also lets you save these images by converting them into .jpg or .pdf files.

Select  in the printer control area to print directly. Or, select the print drop-down arrow for the following options:



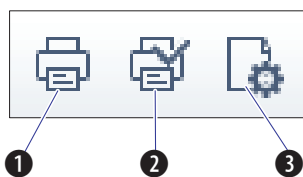
-  **Print Preview.** Used to access the Preview screen.





- Select  to select the required format of the file to be exported and to save the file in that format.



- Print preview also lets you choose between printing directly **(1)**, modifying the printer configuration **(2)**, or adjusting the page settings **(3)**.




-  **Page Setup.** Used to adjust the page settings.

-  **Batch Print.** Used to print data for multiple tubes.
  1. Select **Batch Print**. The Batch Print window appears.



2. Select the tubes to print.
3. Select **OK**.

-  **Batch Export to PDF File.** Used to print a PDF of the data for multiple tubes.
  1. Select **Batch Export to PDF File**. The Batch Export to PDF File window appears.



2. Select the tube to print to PDF.
3. Select **OK**.

## Saving the Experiment

---

Selecting **Save** in the File menu allows you to save the experiment.

Selecting **Save As** and saving the experiment under a different name allows you to create a backup.

Selecting **Save As Template** in the File menu allows you to save the experiment as a template.

## Concluding the Experiment

Conclude the experiment as follows:

- Select **Standby** to return the instrument to the standby state.
- Select **File > Close Experiment** to clear the experiment and return to the Start Page.

**NOTE** If changes were made to the experiment, the software prompts you to save the latest changes in the experiment before returning to the Start Page.

- Shut down the system. Refer to [CHAPTER 9, Daily Shutdown](#).

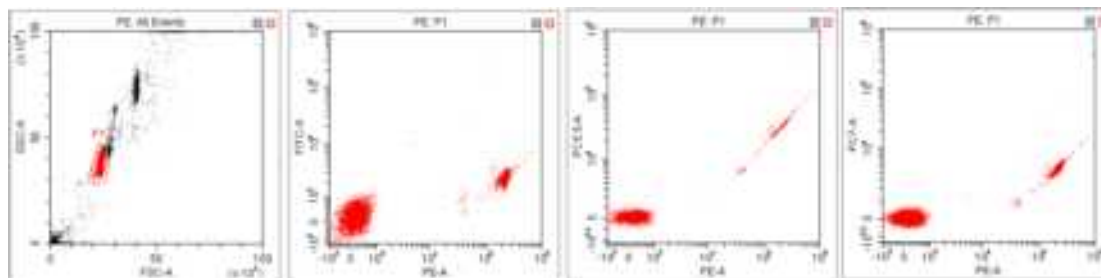
## Overview

This chapter describes how to create a compensation experiment and automatically calculate compensation values after acquiring the data. It also explains how to use these calculations for other experiments.

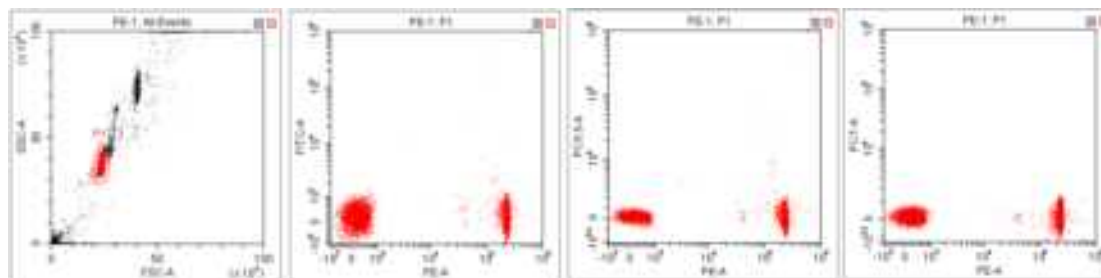
Compensation involves correction for fluorescence spillover emitted by the primary fluorochrome that is detected by the secondary fluorescent channels. For example, the excitation and the resulting fluorescence emission for the PE fluorochrome leads to the spillover fluorescence detected in the ECD, PC5.5, and PC7 channel. Compensation reduces the spillover fluorescence of the PE-positive population to match the background of the PE-negative population in the secondary channels. Compensation requires a single positive and a negative population for every single color sample.

Properly configured compensation minimizes false data interpretation caused by spillover fluorescence from another fluorochrome. Refer to [Figure 7.1](#) and [Figure 7.2](#) for an example of plots before and after compensation. Compensation adjustments can be completed during the data acquisition process or after the data acquisition process is complete.

**Figure 7.1** Before Compensation



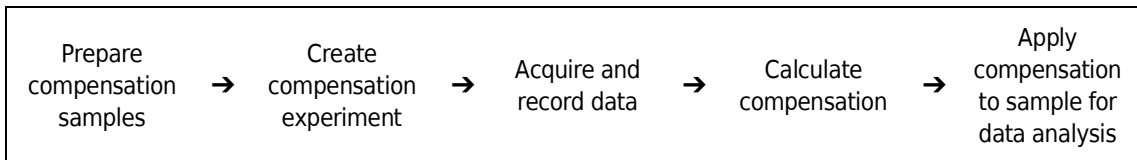
**Figure 7.2** After Compensation



**NOTE** CytExpert compensation allows full matrix compensation, manual, and automatic.

CytExpert compensation also includes a novel Compensation Library for storage of spillover values of dyes to easily determine the correct compensation matrix with new gain settings.

Workflow:



This chapter contains information on:

- [Creating a Compensation Experiment](#)
- [Creating a Compensation Experiment \[With Plate Loader\]](#)
- [Creating the Compensation Matrix from Previously Acquired Data](#)
- [Adjusting Compensation](#)

## Creating a Compensation Experiment

---

Before creating a compensation experiment, you must verify the instrument's detector configuration settings (see [CHAPTER 6, Verifying, Selecting, Editing, and Creating Detector Configuration](#)).

- 1 Select **New Compensation** in the File menu or on the start page to create a new compensation experiment.

**NOTE** The file name of the newly created compensation experiment has a ".xipc" suffix.

- 2 Navigate to the desired file path and select **Save**. The Compensation Setup window appears.

### CAUTION

**Risk of erroneous results. Select an unstained tube, according to which the fluorescence background will be set. If there is not an unstained tube available, then each single color tube must have a negative population.**

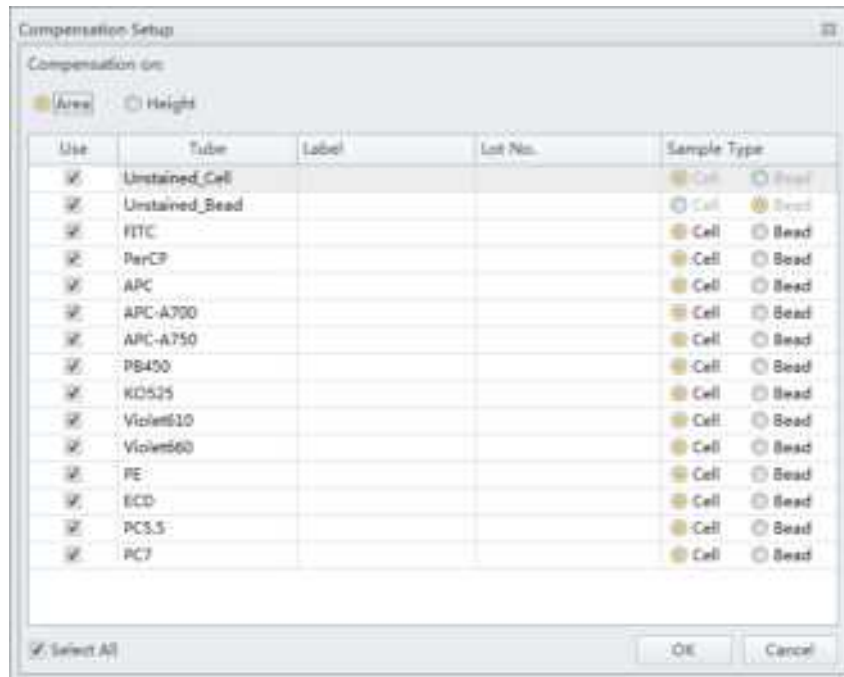
**It is important to specify the appropriate sample type. Otherwise, the background information could be incorrectly calculated and lead to erroneous compensation results.**

- 3 Select the channel requiring compensation calculation and the sample type.

If a negative population is not present in each single color tube, then an unstained control tube is recommended.

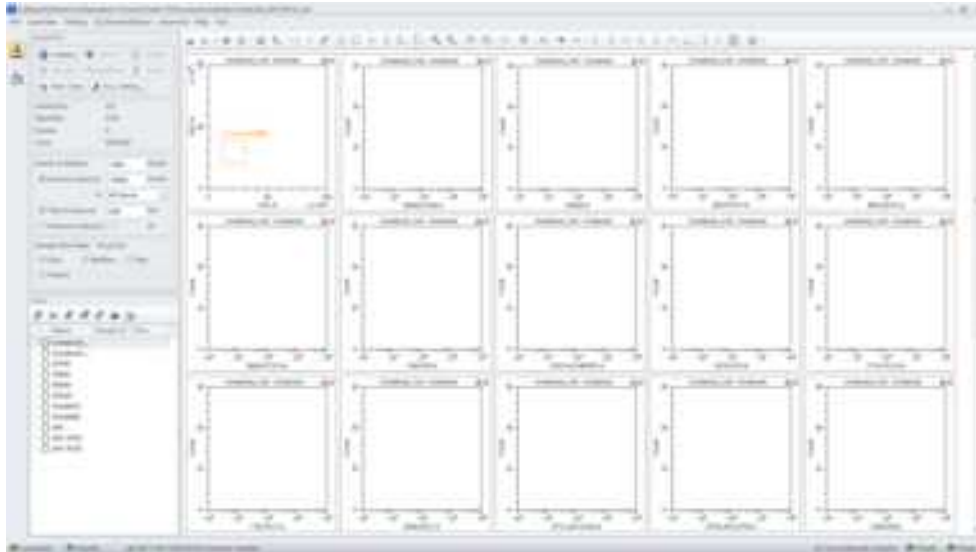
**NOTE** The default selection is **Area**. The unstained negative control tube can be selected if needed.

**NOTE** Label and lot number information can be retained in the Compensation Library to facilitate future compensation calculations.



#### 4 Select **OK**.

After confirmation, the software automatically generates the following compensation experiment.



**NOTE** Select **Area** to calculate compensation based on the Area measured. Alternatively, select **Height** to calculate compensation based on the Height measured.

## Preparing the Compensation Sample

To perform a compensation experiment, prepare:

- A single positive control tube for each color present in the panel
- A negative control tube (optional)

**NOTE** A negative control tube is required if a single positive control tube does not contain a negative population.

For the negative control sample and single positive control sample, you can use blood, cells, or dedicated compensation beads such as VersaComp Antibody Capture Beads. For details, refer to the appropriate reagent instructions for use. The negative control tube is used to determine the autofluorescence of the sample.

## Using Control Samples to Generate the Compensation Matrix

The design of CytoFLEX system makes Gain independent compensation possible. CytExpert software automatically recalculates the compensation matrix according to gain. Manual adjustment may be applied but not necessary because it may introduce inaccurate results.

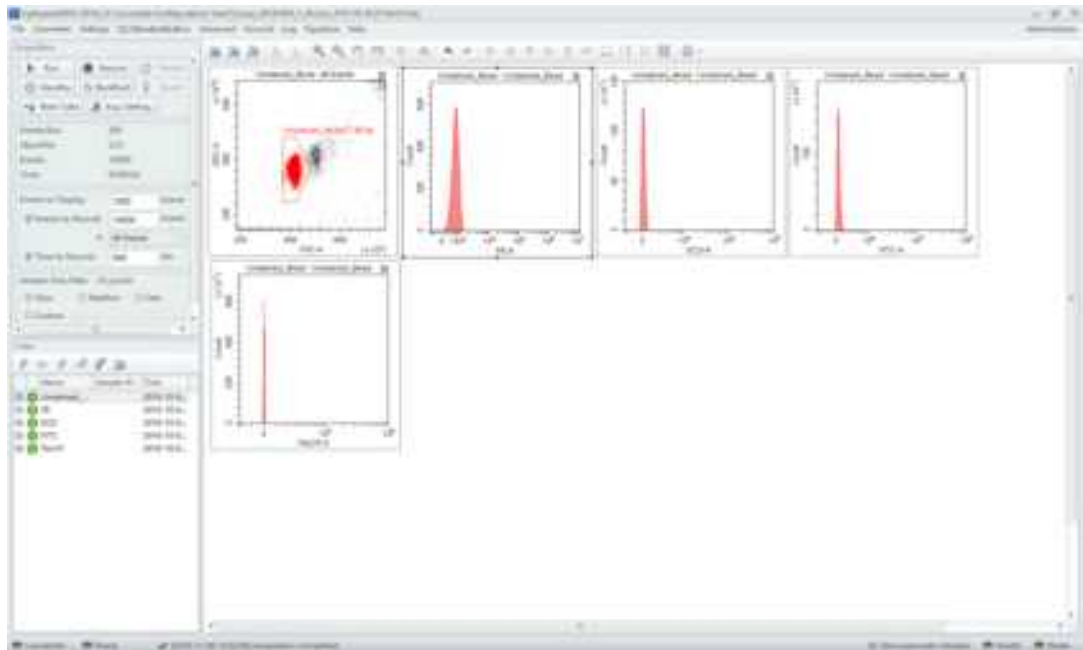
## Defining the Negative Population Using Unstained Samples

- 1 Confirm that the instrument has been initialized. Refer to [CHAPTER 4, Initializing the Instrument](#).

### CAUTION

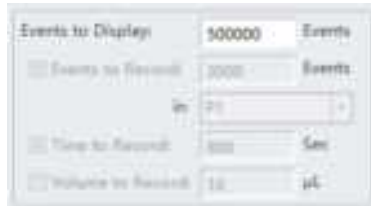
**Risk of erroneous results. Calculations based on excessively small volumes of sampled data can be inaccurate. Ensure that more than 1,000 positive events and more than 1,000 negative events are sampled. If the ratio of positive cells is comparatively low, increase the number of acquisition events to a suitable amount.**

- 2 Import the gain setting and apply the setting to all tubes. Refer to [CHAPTER 6, Adjusting the Gain](#). Use the pan tool to adjust the axis scale so that the sample signal appears in a suitable position. Adjust the gate so that it encloses the target cell population (see [CHAPTER 6, Creating Plots and Gates](#)).



- 3 Place the negative control tube in the sample tube holder.
- 4 Select the unstained tube.
- 5 Select **Run** to load the sample.

- 6** Set an appropriate number of cells to save in Events to Record located on the left side of the screen.



The screenshot shows a software interface with several input fields and checkboxes. The fields are arranged in a grid-like structure. The first row has 'Events to Display' with a value of '500000' and a label 'Events'. The second row has a checkbox for 'Events to Record', a value of '5000', and a label 'Events'. The third row has a label 'in' followed by a dropdown menu showing 'F1'. The fourth row has a checkbox for 'Time to Record', a value of '5000', and a label 'Sec'. The fifth row has a checkbox for 'Volume to Record', a value of '10', and a label 'µL'.

- 7** Select **Record** to save the data.
- 

### Running the Single Positive Control Samples

---

- 1** Place the single positive tube in sample loading position (see [Figure 1.12](#)).
- 
- 2** Select the appropriate, corresponding tube.
- 
- 3** Select **Run** to load the sample.

**CAUTION**

**Risk of erroneous results.** Calculations based on excessively small volumes of sampled data can be inaccurate. Ensure that more than 1,000 positive events and more than 1,000 negative events are sampled. If the number of positive cells is comparatively low, increase the number of acquisition events to a suitable amount.

- 4 Move the gate in the FSC/SSC plot so that it encloses the desired population. Move the positive gate in the plot so that it encloses the positive population. If necessary, move the positive gate so that it encloses the positive population.

**NOTE** Figure 7.3 shows an example of selecting the positive population when the negative population is defined by the unstained sample.

**Figure 7.3** Positive Population Selected from the Single-Stained Sample



1. Positive population

**NOTE** Figure 7.4 shows an example of selecting both the positive and negative populations without an unstained sample.

**Figure 7.4** Positive and Negative Populations Without an Unstained Sample



1. Negative population
2. Positive population

---

**5** Select **Record**.

---

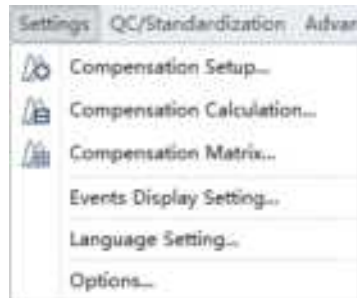
**6** Repeat Steps 1-5 to acquire data from subsequent single positive sample tubes.

---

## Calculating Compensation Values

- 1 Check all acquired sample tubes and confirm that the gating is appropriate.S

- 2 Select  or select **Compensation Calculation** in the Compensation menu to calculate the compensation values.



The Compensation Matrix window appears, displaying the calculated compensation values.

Channel	FTC%	FC%	EC0%	FC1%	FC2%	APC%	APC-A750	APC-A750	PE0%	EC20%	APC0%	APC1%	APC2%
FTC													
PE	0.00												
EC0	12.81	40.7%											
FC1	4.96	18.11	85.09										
FC2	1.36	4.11	18.07	71.81									
APC	0.01	0.01	5.12	1.87	0.22								
APC-A750	0.01	0.11	0.01	0.01	0.00	18.84	0.25	0.07	0.00	0.21	0.00	0.00	0.00
APC-A750	0.10	0.21	0.20	21.46	11.81	13.34	38.39	0.00	0.11	0.11	14.57	23.06	
PE0%	0.10	0.22	0.00	0.04	0.00	0.00	0.15	0.00	0.29	0.02	0.11	0.11	0.11
EC20%	1.86	0.10	0.00	0.01	0.14	0.00	0.00	0.00	0.07	0.00	0.00	0.00	0.00
APC0%	0.07	0.11	0.70	0.02	1.14	0.01	0.00	0.00	0.00	0.10	0.00	0.00	0.00
APC1%	0.09	1.48	1.56	0.22	0.00	1.03	0.10	0.10	0.00	49.21	0.00	0.00	0.00
APC2%	0.11	0.21	0.70	0.02	0.00	0.00	0.10	0.10	0.00	12.20	0.00	0.00	0.00

**NOTE** The primary fluorescence channels are listed in columns; the secondary fluorescence channels are listed in rows.

**NOTE** In the Compensation Matrix window:

- The *Use* checkbox applies the compensation to the selected sample.
- The *Show Autofluorescence* checkbox displays the vectors for the autofluorescence.

**NOTE** The Compensation range is from -500 to 500 depending on the spillover percentage calculated. The CytExpert software displays the value in either black, or orange, or red as a visual clue.

- Black denotes the value falls within 0 - 99.99, which is acceptable.
- Orange denotes the value falls within 100 - 399.99, or -99.99 to -0.01, which requires special attention.
- Red denotes the value is within 400 - 500 or -500 to -100, which is unacceptable.

- 3 Select **Save As** to export the compensation matrix as a .comp file and specify where to save it.

**NOTE** The compensation matrix can also be imported for use in other experiments.

- 
- 4 Select **Save To Compensation Library** to save the single color compensation values in the compensation library.
- 
- 5 Specify the key words and select **OK**.



**NOTE** The settings stored in the compensation library are specific to the detector configuration. The compensation library can only be applied when the detector configurations are the same.

At any time, saved compensation experiments can be reopened and the compensation values recalculated.

- 
- 6 Select **Close**.
- 

## Creating a Compensation Experiment [With Plate Loader]

---

Before creating a compensation experiment, you must verify the instrument's detector configuration settings (see [CHAPTER 6, Verifying, Selecting, Editing, and Creating Detector Configuration](#)).

- 
- 1 Select **New Compensation** in the File menu or on the start page to create a new compensation experiment.  
**NOTE** The file name of the newly created compensation experiment has a ".xltc" suffix.
- 
- 2 Navigate to the desired file path and select **Save**. The Compensation Setup window appears.

- 3 Select the plate type and sampling sequence located in the top, right of the Compensation Setup window.

**CAUTION**

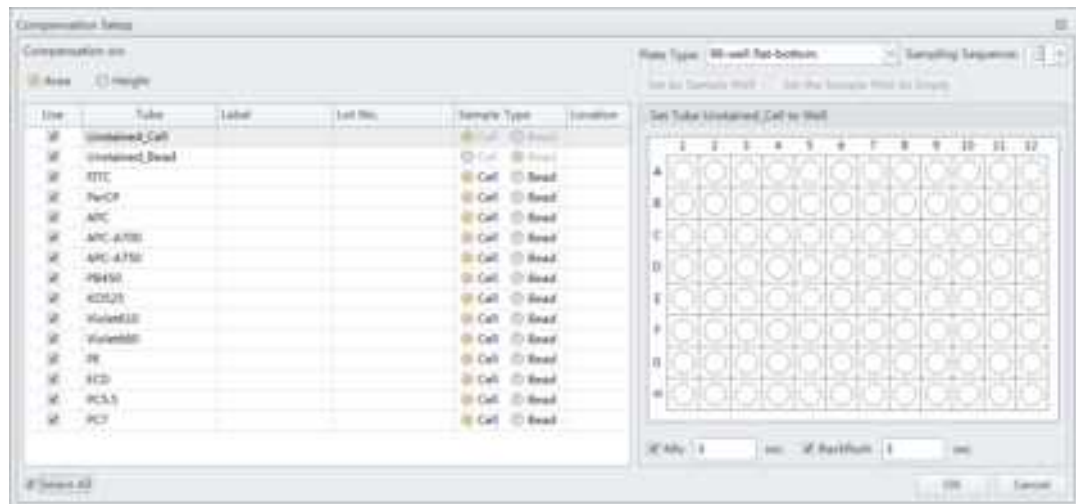
**Risk of erroneous results. Select an unstained tube, according to which the fluorescence background will be set. If there is not an unstained tube, then each single marker tube must have a negative population.**

**It is important to specify the appropriate sample type. Otherwise, the background information could be incorrectly calculated and lead to erroneous compensation results.**

- 4 Select the channel requiring compensation calculation, and the sample type.  
If a negative population is not present in each single color well, then an unstained control well is recommended.

**NOTE** The default selection is **Area**. The unstained negative control well can be selected if needed.

**NOTE** Label and lot number information can be retained in the Compensation Library to facilitate future compensation calculations.

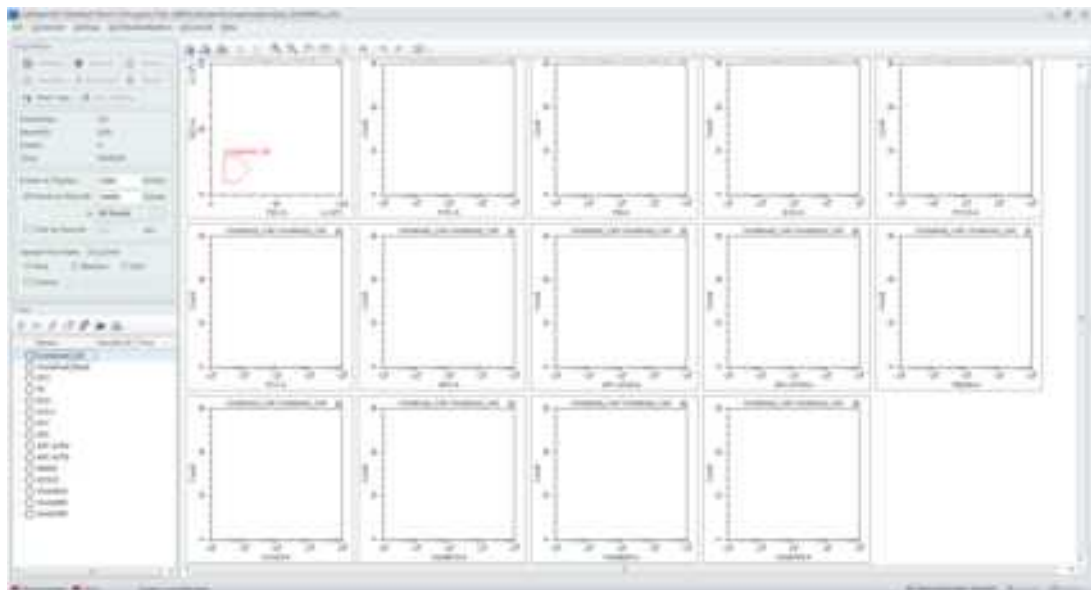


- 5 Select the Mix and Backflush settings in the bottom, right of the Compensation Setup window.

- 
- 6** Assign the well locations.
- Select the fluorochrome.
  - Select the desired sample well location for the fluorochrome.
  - Select **Set As Sample Well**.
- NOTE** The well location populates in the location column.
- Repeat Steps a-c for each fluorochrome.
- 

- 7** Select **OK**.

After confirmation, the software automatically generates the following compensation experiment.



**NOTE** Select Area to calculate compensation based on the Area measured. Alternatively, select Height to calculate compensation based on the Height measured.

**NOTE** If the plate settings require modification, select . The Compensation Setup window appears.

- 
- 8** Before acquiring data, ensure the plate has been loaded properly. Data can be acquired as a single well or as a set of wells. Refer to [CHAPTER 6, Sampling and Collecting Data \[With Plate Loader\]](#).
-

## Preparing the Compensation Sample

To perform a compensation experiment, prepare:

- A single positive control well for each color
- A negative control well (optional)

**NOTE** A negative control well is required if a single positive control well does not contain a negative population.


For the negative control sample and single positive control sample, you can use blood, cell lines, or dedicated compensation beads such as VersaComp Antibody Capture Beads. For details, refer to the appropriate reagent instructions for use. The negative control tube is used to determine the autofluorescence of the sample.

## Using Control Samples to Generate the Compensation Matrix

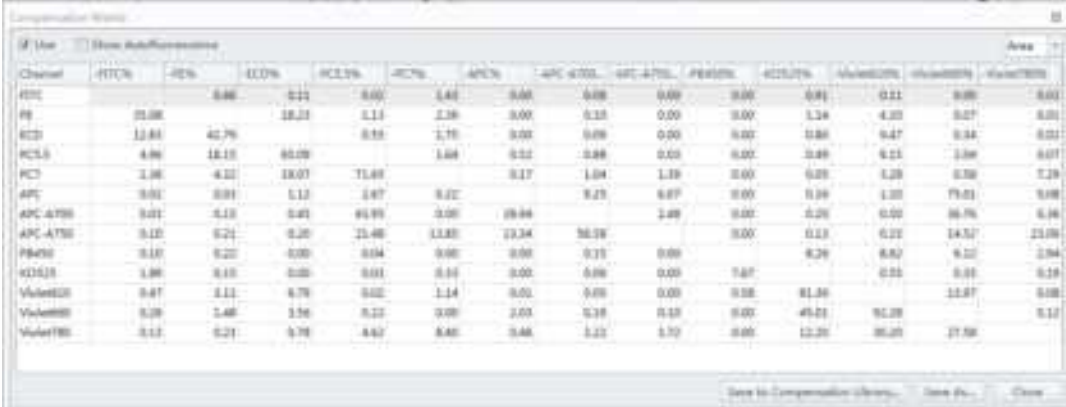
Refer to [CHAPTER 7, Defining the Negative Population Using Unstained Samples](#) and [CHAPTER 7, Running the Single Positive Control Samples](#).

## Calculating Compensation Values

1 Check all acquired sample tubes and confirm that the gating is appropriate.

2 Select  or select **Compensation Calculation** in the Settings menu to calculate the compensation values.

The Compensation Matrix window appears, displaying the calculated compensation values.



Channel	-FITC%	-PE%	-APC%	-APC-ALLO%	-APC-ATRO%	-APC-ATRO%	-APC-ATRO%	-APC-ATRO%	-APC-ATRO%	-APC-ATRO%	-APC-ATRO%	-APC-ATRO%	-APC-ATRO%	-APC-ATRO%	-APC-ATRO%	-APC-ATRO%	-APC-ATRO%	-APC-ATRO%	-APC-ATRO%
FITC																			
PE	19.08	0.86	0.21	0.00	0.40	0.00	0.00	0.00	0.00	0.00	0.00	0.00	0.00	0.00	0.00	0.00	0.00	0.00	0.00
APC	13.84	40.79	18.23	1.13	2.38	0.00	0.13	0.00	0.00	0.00	0.00	0.00	0.00	0.00	0.00	0.00	0.00	0.00	0.00
APC-ALLO	4.96	18.15	0.00	0.00	1.68	0.00	0.00	0.00	0.00	0.00	0.00	0.00	0.00	0.00	0.00	0.00	0.00	0.00	0.00
APC-ATRO	2.38	4.12	18.07	23.69	0.17	0.00	1.04	1.29	0.00	0.00	0.00	0.00	0.00	0.00	0.00	0.00	0.00	0.00	0.00
APC-ATRO	0.01	0.01	1.13	1.87	0.12	0.00	0.23	0.87	0.00	0.00	0.00	0.00	0.00	0.00	0.00	0.00	0.00	0.00	0.00
APC-ATRO	0.01	0.13	0.01	0.00	0.00	0.00	0.00	0.00	0.00	0.00	0.00	0.00	0.00	0.00	0.00	0.00	0.00	0.00	0.00
APC-ATRO	0.13	0.21	0.00	23.48	13.85	13.34	0.00	0.00	0.00	0.00	0.00	0.00	0.00	0.00	0.00	0.00	0.00	0.00	0.00
APC-ATRO	0.13	0.21	0.00	0.00	0.00	0.00	0.00	0.00	0.00	0.00	0.00	0.00	0.00	0.00	0.00	0.00	0.00	0.00	0.00
APC-ATRO	0.01	0.01	0.00	0.00	0.00	0.00	0.00	0.00	0.00	0.00	0.00	0.00	0.00	0.00	0.00	0.00	0.00	0.00	0.00
APC-ATRO	0.01	0.13	0.00	0.00	0.00	0.00	0.00	0.00	0.00	0.00	0.00	0.00	0.00	0.00	0.00	0.00	0.00	0.00	0.00
APC-ATRO	0.01	0.01	0.00	0.00	0.00	0.00	0.00	0.00	0.00	0.00	0.00	0.00	0.00	0.00	0.00	0.00	0.00	0.00	0.00
APC-ATRO	0.01	0.01	0.00	0.00	0.00	0.00	0.00	0.00	0.00	0.00	0.00	0.00	0.00	0.00	0.00	0.00	0.00	0.00	0.00

3 Select **Save As** to export the compensation matrix as a .comp file and specify where to save it.

**NOTE** The compensation matrix can also be imported for use in other experiments.

- 
- 4 Select **Save To Compensation Library** to save the single color compensation values in the compensation library.
- 
- 5 Specify the key words and select **OK**.



**NOTE** The settings stored in the compensation library are specific to the detector configuration. The compensation library can only be applied when the detector configurations are the same.

At any time, saved compensation experiments can be reopened and the compensation values recalculated.

- 
- 6 Select **Close**.
- 

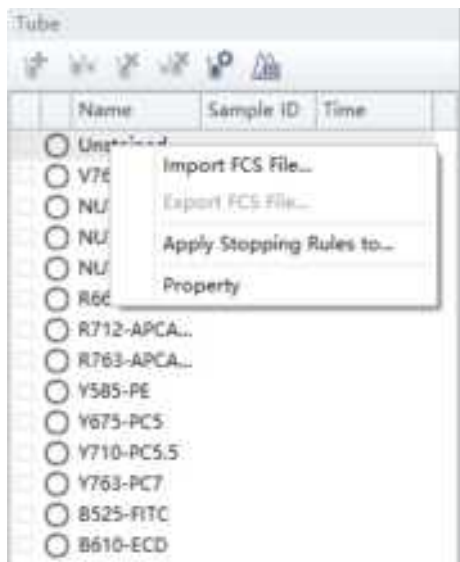
## Creating the Compensation Matrix from Previously Acquired Data

---

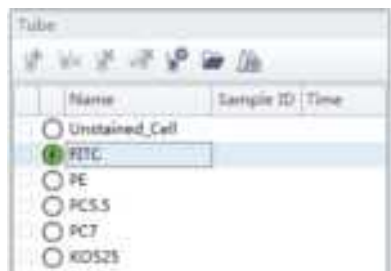
The software supports importing single color data acquired from other experiments into a compensation experiment to perform compensation calculations. The data to be imported must match the active detector configuration at the time that the compensation experiment was created. Otherwise, the data cannot be imported. It is important to ensure that imported data comes from the same instrument and uses the same configuration and channels. Data originating from a different instrument will cause erroneous calculations.

- 
- 1 Select **New Compensation** from the File menu or the start page.
- 
- 2 To create a compensation experiment, select the required channels. Refer to [CHAPTER 6, Setting the Channel and Label](#).

- 3 Right-click on the appropriate test tube and select **Import FCS File**. Locate the corresponding data file and import the file. Only files compatible with the detector configuration are supported by the software for importing.



**F** in front of a test tube indicates that the corresponding data have been imported.



- 4 After importing the data, adjust the gates to properly identify the positive population and the negative population for each single-color samples.

- 5 Calculate the compensation values and export them. Refer to [Calculating Compensation Values](#).

**NOTE** The CytoFLEX platform uses the positive-negative method to calculate compensation.

$$B(k + 1) = \frac{s(k) - B(k)}{1024} + B(k)$$

Where S(k) denotes the real-time background noise being measured.


Where B(k) denotes the background noise being filtered.

Where B(k+1) denotes the noise background base being filtered at the next point.

## Adjusting Compensation

### Manually Adjusting Compensation

The compensation can be manually adjusted in an experiment in two ways:

- Select the populations where needs to be adjusted in the bivariate plot. Select  from the graphic control area, then click and drag the mouse pointer up and down or left and right inside the plot to adjust compensation.
- Select **Compensation Matrix** in the Setting menu to open the compensation matrix. Adjust the compensation value between the primary channel and the secondary channel.

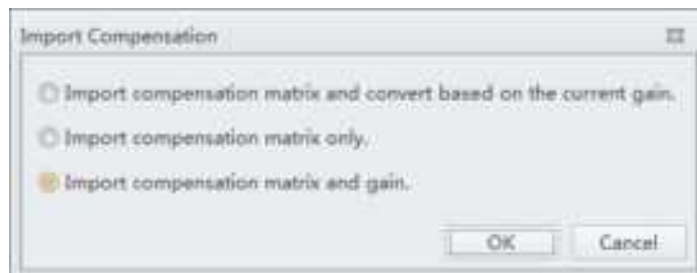
### Importing and Exporting Compensation

#### Importing Compensation Settings from Compensation Matrix Files

- 1 Select the desired sample tube for importing compensation values.
- 2 Select **Compensation Matrix** in the Setting menu.
- 3 Select **Import** and locate the path where compensation matrix files are saved. Select the corresponding compensation matrix file (.comp) to import the compensation values.  
You can also select **Import from Library** to import compensation values from the compensation library. The Import from Compensation Library window appears. Refer to [Importing Compensation Settings from the Compensation Library](#).

Both methods allow you to apply the gain independent compensation capability, i.e. importing the compensation values with or without recalculating the compensation matrix based on the gain settings.

- 4 After opening the desired compensation file, the Import Compensation window appears. Select one of the following:
  - Import compensation matrix and convert based on the current gain.
  - Import compensation matrix only.
  - Import compensation matrix and gain.



#### NOTE

- If the tube does not have any data when importing compensation values calculated from other instrument settings, the software prompts you to select whether the gain settings must be imported as well. Select **Yes** to import fluorescence channel gains settings along with the rest of the data. Select **No** to allow the CytExpert software to adjust the compensation matrix values based on the current gain settings.
- If the tube does have data when importing compensation values from other instrument settings, the software prompts you to select whether the compensation values are adjusted based on the current gain settings.
- It is important to note that automatic adjustments to compensation values calculated from other instrument gain settings could result in incorrect compensation. Always review the data after importing compensation values to ensure the sample is compensated properly.

- 5 Select **OK**.

- 6 If necessary, select **Apply to** to apply the compensation values to the selected test tubes.

- 7 Select **Close**.

## Importing Compensation Settings from the Compensation Library

You can choose which single color data to include from the compensation library. Only single color data in the compensation library from the same detector configuration can be imported into the compensation matrix.

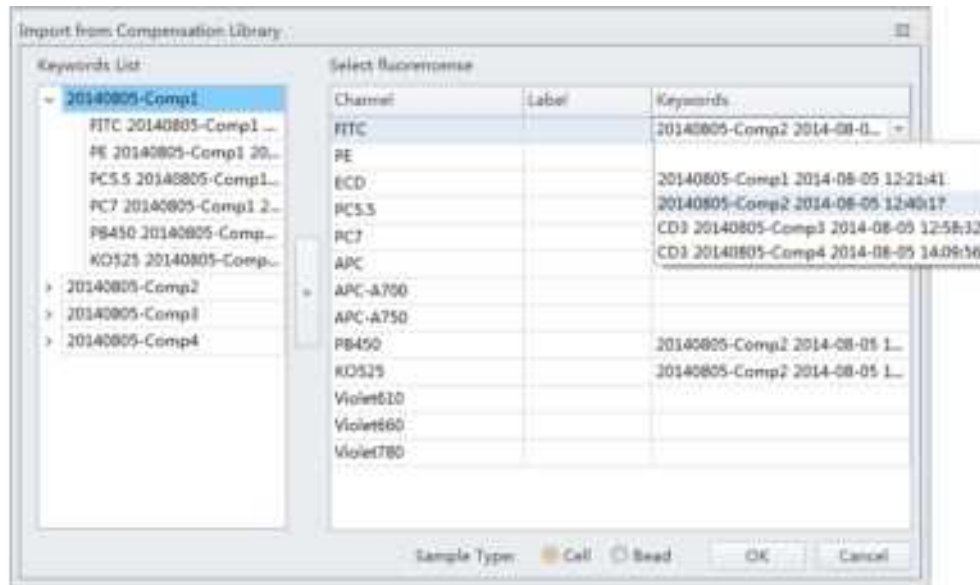
**NOTE** Files available in the compensation library are configuration-specific. The compensation library only displays the files created under the current default configuration.

- 1 Select **Import From Compensation Library** to select which compensation values to import from the compensation library.

[CytoFLEX LX Shown]

Area	Channel	SPCA SPCA %	SPCB	SPCC SPCC %	SPCD SPCD %	SPCE	SPCF	SPCG	SPCH	SPCI	SPCJ	SPCK	SPCL	SPCM	SPCN	SPCO	SPCP	SPCQ	SPCR	SPCS	SPCT	SPCU	SPCV	SPCW	SPCX	SPCY	SPCZ
0.00	SPCA	0.00	0.00	0.00	0.00	0.00	0.00	0.00	0.00	0.00	0.00	0.00	0.00	0.00	0.00	0.00	0.00	0.00	0.00	0.00	0.00	0.00	0.00	0.00	0.00	0.00	0.00
0.00	SPCB	0.00	0.00	0.00	0.00	0.00	0.00	0.00	0.00	0.00	0.00	0.00	0.00	0.00	0.00	0.00	0.00	0.00	0.00	0.00	0.00	0.00	0.00	0.00	0.00	0.00	0.00
0.00	SPCC	0.00	0.00	0.00	0.00	0.00	0.00	0.00	0.00	0.00	0.00	0.00	0.00	0.00	0.00	0.00	0.00	0.00	0.00	0.00	0.00	0.00	0.00	0.00	0.00	0.00	0.00
0.00	SPCD	0.00	0.00	0.00	0.00	0.00	0.00	0.00	0.00	0.00	0.00	0.00	0.00	0.00	0.00	0.00	0.00	0.00	0.00	0.00	0.00	0.00	0.00	0.00	0.00	0.00	0.00
0.00	SPCE	0.00	0.00	0.00	0.00	0.00	0.00	0.00	0.00	0.00	0.00	0.00	0.00	0.00	0.00	0.00	0.00	0.00	0.00	0.00	0.00	0.00	0.00	0.00	0.00	0.00	0.00
0.00	SPCF	0.00	0.00	0.00	0.00	0.00	0.00	0.00	0.00	0.00	0.00	0.00	0.00	0.00	0.00	0.00	0.00	0.00	0.00	0.00	0.00	0.00	0.00	0.00	0.00	0.00	0.00
0.00	SPCG	0.00	0.00	0.00	0.00	0.00	0.00	0.00	0.00	0.00	0.00	0.00	0.00	0.00	0.00	0.00	0.00	0.00	0.00	0.00	0.00	0.00	0.00	0.00	0.00	0.00	0.00
0.00	SPCH	0.00	0.00	0.00	0.00	0.00	0.00	0.00	0.00	0.00	0.00	0.00	0.00	0.00	0.00	0.00	0.00	0.00	0.00	0.00	0.00	0.00	0.00	0.00	0.00	0.00	0.00
0.00	SPCI	0.00	0.00	0.00	0.00	0.00	0.00	0.00	0.00	0.00	0.00	0.00	0.00	0.00	0.00	0.00	0.00	0.00	0.00	0.00	0.00	0.00	0.00	0.00	0.00	0.00	0.00
0.00	SPCJ	0.00	0.00	0.00	0.00	0.00	0.00	0.00	0.00	0.00	0.00	0.00	0.00	0.00	0.00	0.00	0.00	0.00	0.00	0.00	0.00	0.00	0.00	0.00	0.00	0.00	0.00
0.00	SPCK	0.00	0.00	0.00	0.00	0.00	0.00	0.00	0.00	0.00	0.00	0.00	0.00	0.00	0.00	0.00	0.00	0.00	0.00	0.00	0.00	0.00	0.00	0.00	0.00	0.00	0.00
0.00	SPCL	0.00	0.00	0.00	0.00	0.00	0.00	0.00	0.00	0.00	0.00	0.00	0.00	0.00	0.00	0.00	0.00	0.00	0.00	0.00	0.00	0.00	0.00	0.00	0.00	0.00	0.00
0.00	SPCM	0.00	0.00	0.00	0.00	0.00	0.00	0.00	0.00	0.00	0.00	0.00	0.00	0.00	0.00	0.00	0.00	0.00	0.00	0.00	0.00	0.00	0.00	0.00	0.00	0.00	0.00
0.00	SPCN	0.00	0.00	0.00	0.00	0.00	0.00	0.00	0.00	0.00	0.00	0.00	0.00	0.00	0.00	0.00	0.00	0.00	0.00	0.00	0.00	0.00	0.00	0.00	0.00	0.00	0.00
0.00	SPCO	0.00	0.00	0.00	0.00	0.00	0.00	0.00	0.00	0.00	0.00	0.00	0.00	0.00	0.00	0.00	0.00	0.00	0.00	0.00	0.00	0.00	0.00	0.00	0.00	0.00	0.00
0.00	SPCP	0.00	0.00	0.00	0.00	0.00	0.00	0.00	0.00	0.00	0.00	0.00	0.00	0.00	0.00	0.00	0.00	0.00	0.00	0.00	0.00	0.00	0.00	0.00	0.00	0.00	0.00
0.00	SPCQ	0.00	0.00	0.00	0.00	0.00	0.00	0.00	0.00	0.00	0.00	0.00	0.00	0.00	0.00	0.00	0.00	0.00	0.00	0.00	0.00	0.00	0.00	0.00	0.00	0.00	0.00
0.00	SPCR	0.00	0.00	0.00	0.00	0.00	0.00	0.00	0.00	0.00	0.00	0.00	0.00	0.00	0.00	0.00	0.00	0.00	0.00	0.00	0.00	0.00	0.00	0.00	0.00	0.00	0.00
0.00	SPCS	0.00	0.00	0.00	0.00	0.00	0.00	0.00	0.00	0.00	0.00	0.00	0.00	0.00	0.00	0.00	0.00	0.00	0.00	0.00	0.00	0.00	0.00	0.00	0.00	0.00	0.00
0.00	SPCT	0.00	0.00	0.00	0.00	0.00	0.00	0.00	0.00	0.00	0.00	0.00	0.00	0.00	0.00	0.00	0.00	0.00	0.00	0.00	0.00	0.00	0.00	0.00	0.00	0.00	0.00
0.00	SPCU	0.00	0.00	0.00	0.00	0.00	0.00	0.00	0.00	0.00	0.00	0.00	0.00	0.00	0.00	0.00	0.00	0.00	0.00	0.00	0.00	0.00	0.00	0.00	0.00	0.00	0.00
0.00	SPCV	0.00	0.00	0.00	0.00	0.00	0.00	0.00	0.00	0.00	0.00	0.00	0.00	0.00	0.00	0.00	0.00	0.00	0.00	0.00	0.00	0.00	0.00	0.00	0.00	0.00	0.00
0.00	SPCW	0.00	0.00	0.00	0.00	0.00	0.00	0.00	0.00	0.00	0.00	0.00	0.00	0.00	0.00	0.00	0.00	0.00	0.00	0.00	0.00	0.00	0.00	0.00	0.00	0.00	0.00
0.00	SPCX	0.00	0.00	0.00	0.00	0.00	0.00	0.00	0.00	0.00	0.00	0.00	0.00	0.00	0.00	0.00	0.00	0.00	0.00	0.00	0.00	0.00	0.00	0.00	0.00	0.00	0.00
0.00	SPCY	0.00	0.00	0.00	0.00	0.00	0.00	0.00	0.00	0.00	0.00	0.00	0.00	0.00	0.00	0.00	0.00	0.00	0.00	0.00	0.00	0.00	0.00	0.00	0.00	0.00	0.00
0.00	SPCZ	0.00	0.00	0.00	0.00	0.00	0.00	0.00	0.00	0.00	0.00	0.00	0.00	0.00	0.00	0.00	0.00	0.00	0.00	0.00	0.00	0.00	0.00	0.00	0.00	0.00	0.00

- 2 In the Keywords column, the corresponding compensation values can be selected for each channel. The compensation values of the same keyword can also be selected using the drop-down menus in the Keywords column.



- 3 Select **OK** to import the compensation values.

## Exporting Compensation Settings

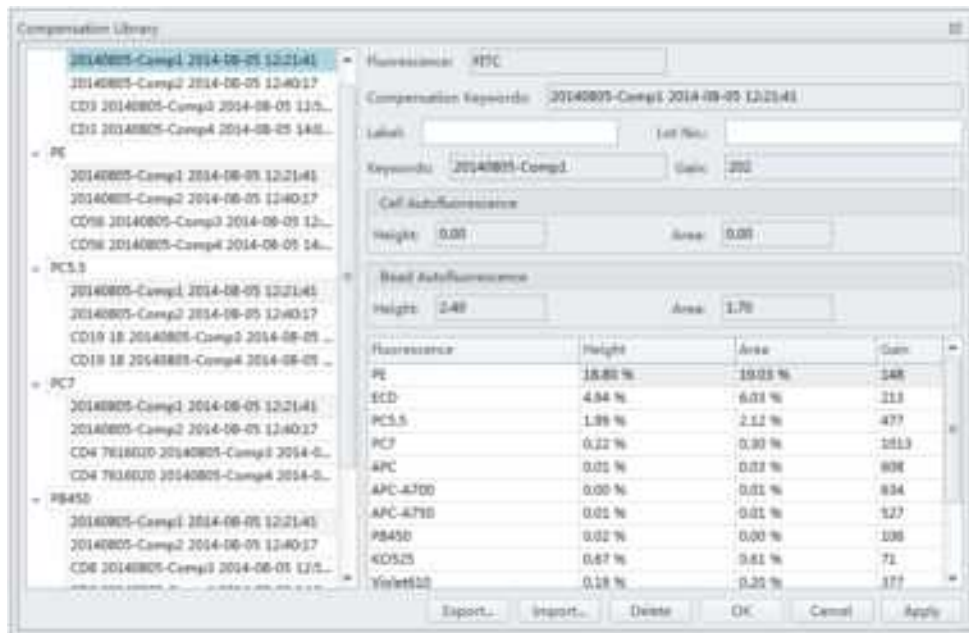
- 1 Select the desired sample tube to export.
- 2 Select **Compensation Matrix** in the Setting menu.
- 3 Select **Export** to specify a path and filename for the compensation file you are saving.



## Managing the Compensation Library

Compensation values can be managed in the Compensation Library.

- 1 Select **Compensation Library** from the Settings menu. The Compensation Library window appears.



**NOTE** The Compensation Library is arranged by fluorescence detection channels.

- 2 Select the desired single color sample. The compensation information appears on the right side of the window.

**NOTE** Existing compensation values (height and area) can be modified by double-clicking the appropriate column in the Compensation Library window.

- 3 Enter the Label and Lot No. for the specified single color sample.

- 4 Select **OK**.

## Adding Channels for Compensation

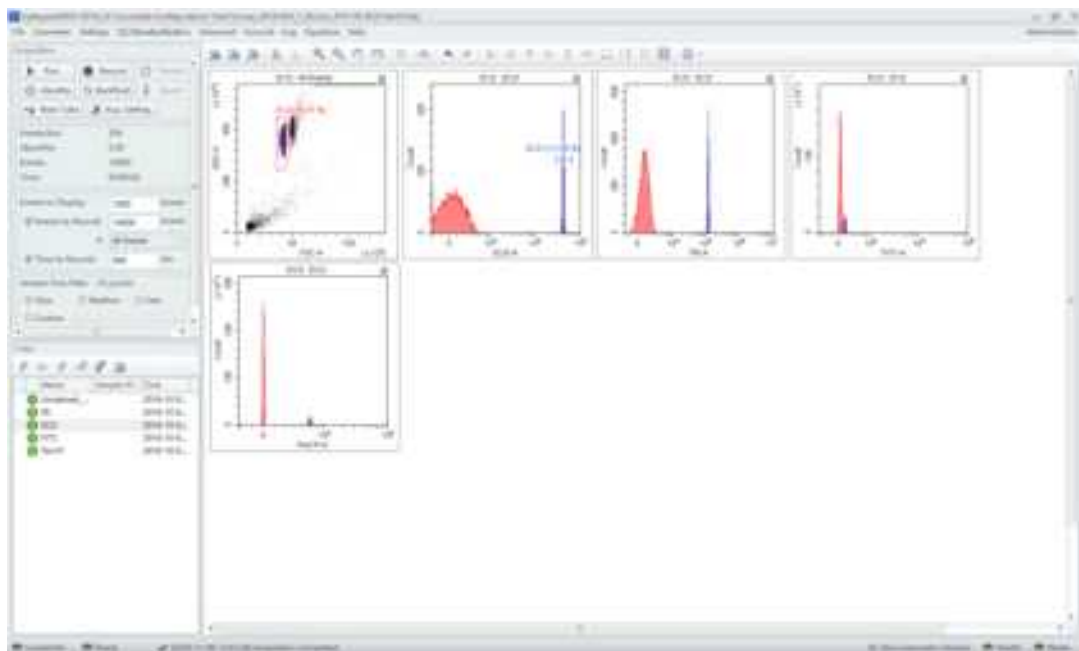
Channels requiring compensation calculations that have not been previously acquired can be added to the compensation experiment by acquiring the necessary positive tubes.

1 In the compensation experiment, select  in the compensation controls, or select **Compensation Setup** in the Compensation menu. The Compensation Setup window appears.

2 Select the channel that needs to be added and select **OK**.

The software automatically adds a new single positive tube to the compensation experiment. It also adds a plot with appropriate parameters in the negative control tube.

**NOTE** It is important to ensure that the data for the previously acquired negative control now includes the data of the newly added channel and that the settings are correct. Otherwise, you must reacquire the negative control tube and adjust the gain.



3 Repeat Steps 1-2 to detect and acquire newly added single positive sample data.

4 Repeat [Calculating Compensation Values](#) to recalculate and export the compensation results.

## Overview

---

This chapter discusses how to use the Analysis screen to analyze data. Data can be analyzed using any computer equipped with the CytExpert software. No online connection is required.

Workflow:

Import experiment or data → Plot and configure statistics → Export results

This chapter contains information on:

- [Copying Experiments and Importing Data](#)
- [Setting the Plots and Statistics](#)
- [Calculating Sample Volume and Concentration](#)
- [Adjusting Compensation Settings](#)
- [Exporting Results](#)

## Copying Experiments and Importing Data

---

### Copying a Previously Acquired Experiment

Experiments acquired by other CytoFLEX instruments using CytExpert software can be imported to your computer for analysis, provided your computer also uses CytExpert software.

Select **Open Experiment** from the Start page or select **Open Experiment** in the File menu to open the copied experiment. Then, select **Save As**.

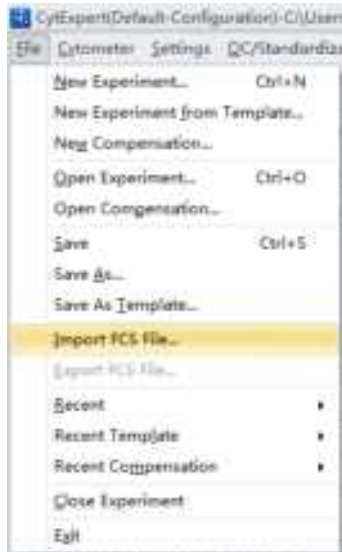
**NOTE** The .xit and data folder must be stored in the same path.

### Importing Previously Acquired Data

The CytExpert software can import and analyze compatible FCS data files acquired by other CytoFLEX flow cytometers.

- 1 Create a new experiment or open a saved experiment. Refer to [CHAPTER 6, Creating an Experiment](#).

- 2 In the new or opened experiment, select **Import FCS File** in the File menu to import the data files.



Imported data files appear in the Tube screen.


The **F** symbol in front of each data tube indicates that the data tube is an imported data file. Imported data files are copied and saved in the folder where the current experiment data files are saved.

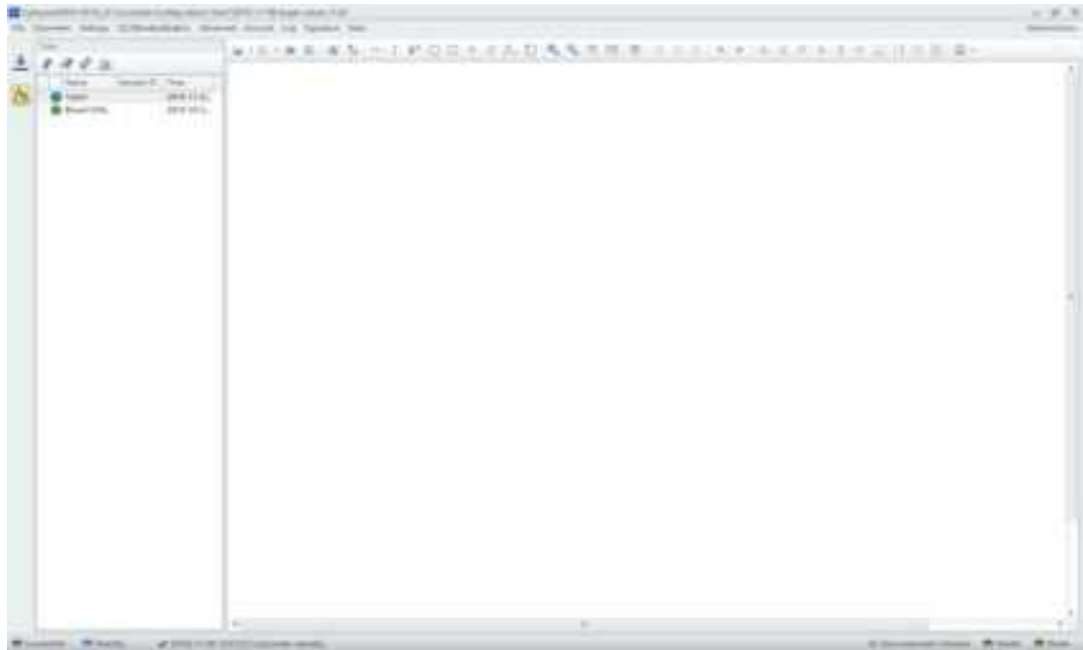
## Setting the Plots and Statistics



---

### Opening the Analysis Screen

---

- 1 Select  on the left to enter the Analysis screen.



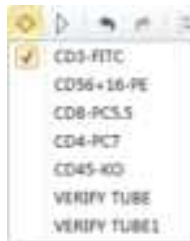
- 2 Copy plots obtained during data acquisition.
  - a. If you need original plots used during data acquisition, select  to access the Acquisition screen.
  - b. Select the appropriate plots.
  - c. Right-click the selected plots and select **Copy** from the drop-down menu or press Ctrl+C to copy.
  - d. Select  to return to the Analysis screen.
  - e. Select the required test tube from the tube list on the left side of the screen.
  - f. Right-click the plot area and select **Paste** from the drop-down menu or press Ctrl+V to paste the plot.


**NOTE** Pasted plots include all gates, but the gate names are reassigned.

- 
- 3** New plots can be created according to need. After selecting the test tubes requiring analysis, use the plotting control buttons at the top of the screen to create a new plot.

**NOTE** Each graph in the **Analysis** screen may correspond to different data. Pay special attention to each plot's heading to avoid mistakes during analysis.

- 
- 4** Use the sample selection controls in the graphics controls toolbar at the top of the page (see [Figure 2.1](#)) to change the data displayed in a plot.



- a.** Select the plot requiring a change to the data displayed. By pressing and holding the Ctrl key while selecting plots, you can select several plots at one time.
- b.** Select one of the two triangular sample selection buttons ( ◀ or ▶ ) to choose between the previous sample and the next sample, or select  to specify which data to display.

## Creating Histogram and Dot Plot Overlays

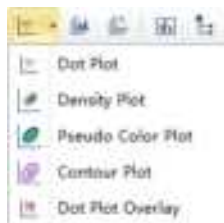
The CytExpert software supports histogram and dot plot data overlay functionality, allowing you to combine data from differing sources onto the same histogram or dot plot.

- 1 Select **Histogram Overlay** under the histogram icon drop-down list to create a new multi-data histogram.




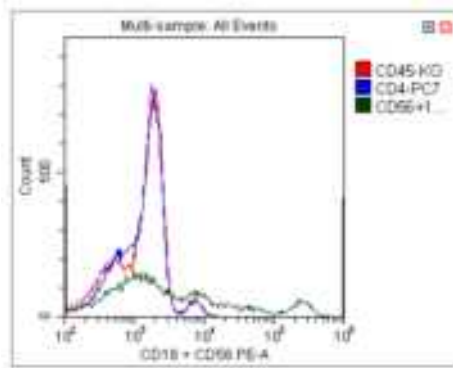
Or

Select **Dot Plot Overlay** under the dot plot icon drop-down list to create a new dot plot overlay.



**IMPORTANT** A maximum of 10 samples can be overlaid.

- 2 Select  to select samples for overlay display. Or, drag and drop samples from the tube list on the left into the histogram or dot plot overlay. The software automatically assigns different colors to different data.



To remove a sample, select  and uncheck the sample. Or, right-click the color legend and select **Remove [sample name]** or **Remove All Sample**. The corresponding data will no longer appear on the graph.

- 3 To change the color selections, right-click on the sample name in the legend located on the right side of the plot and select **Color** from the drop-down menu. A color pallet appears.

For configuring gates and generating statistics, refer to [CHAPTER 6, Data Acquisition and Sample Analysis](#).

## Calculating Sample Volume and Concentration

---

The CytoFLEX flow cytometer supports the calculation of the sample concentration based on the volume consumed and/or based on the known concentration of reference beads.

**NOTE** If necessary, calibrate the sample uptake rate (see [CHAPTER 12, Calibrating the Sample Flow Rate](#)) prior to collecting data for volumetric analysis:

- Select the *cells/μL(V)* checkbox to calculate concentration directly.

**NOTE** The direct calculation of concentration can be affected by several conditions such as, the sample's viscosity and sample mixing. Uncalibrated sample volume uptake rates may lead to erroneous results.

- If using reference beads to calculate the concentration, select the *cells/μL(B)* checkbox and select the gated **Beads Population**. Enter the total number of reference beads as the **Beads Count**, as well as the sample volume in total. The software automatically calculates the original sample concentration based on the input values. (You can also enter the reference bead concentration directly in the beads count field and set the sample volume as 1.)

To obtain accurate calculations, throughout the data acquisition process, ensure that:

- The sample concentration is  $2 \times 10^4$ - $10^7$  units/mL.
- Samples are thoroughly mixed before loading and that they exhibit no apparent subsidence throughout the testing process.
- The detection rate is maintained at less than 10,000 events/second throughout the sampling process. When the detection rate does not exceed the stated event rate, running at medium to high acquisition speeds are considered more accurate.
- A constant sampling rate is maintained when recording data.
- You acquire at least 10 μL of sampling volume.

In the Statistics Setting screen, select **Volume** and the concentration item to see the corresponding information in the statistics table.

**NOTE** While collecting samples, instantaneous data calculation can appear inaccurate. Regard the calculation as accurate only after data acquisition has been completed.


[CytoFLEX LX Shown]



[CytoFLEX LX Shown]



## Adjusting Compensation Settings

Data compensation can be carried out at any time. You can select the desired tube in the tube list on the left side of the screen and select  in the compensation controls, or select **Compensation Setup** in the Compensation menu. Refer to [CHAPTER 7, Adjusting Compensation](#), for detailed instructions on adjusting compensation settings.

## Exporting Results

---

Refer to [CHAPTER 6, Data Acquisition and Sample Analysis](#).



## Overview

---

This chapter provides procedures for shutting down the CytoFLEX instrument.

Workflow:

Prepare the cleaning solution → Clean the instrument → Turn the instrument off

This chapter contains information on:

- [Preparing the Cleaning Solution](#)
- [Running Daily Clean](#)
- [Shutting Down the Instrument](#)
- [Auto Shutdown \[CytoFLEX LX Only\]](#)

## Preparing the Cleaning Solution

---

### Required materials

Materials to prepare:

- 12 x 75 mm sample loading tubes
- FlowClean
- Deionized water
- Bleach

Set aside 2 mL of FlowClean in one sample tube and 3 mL of the deionized water in a separate sample tube.

## Running Daily Clean



**IMPORTANT** It is recommended to perform Daily Clean before shutting down the instrument to clean the sample line. Otherwise, the CytExpert software will prompt you to run Daily Clean repeatedly when you shut down the instrument

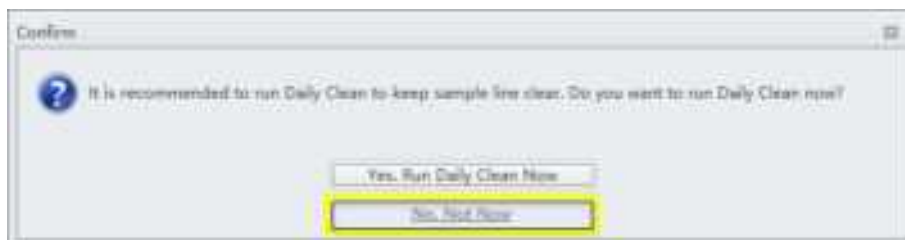
- 1 Verify that the instrument is in the initialized state.

- 2 Run Daily Clean to clean the sample line. Refer to [CHAPTER 11, Daily Clean](#) or [CHAPTER 11, Daily Clean \[With Plate Loader\]](#).
- 3 If necessary, empty all waste liquid from the waste container. Refer to [CHAPTER 12, Emptying the 4 L Waste Container](#).
- 4 Remove the sample tube from the instrument and store according to your laboratory procedures.
- 5 If there are any spills, clean the sample station. Refer to [CHAPTER 11, Cleaning the Sample Station](#).

## Shutting Down the Instrument

- 1 Confirm that the instrument is in the standby state.
- 2 Proceed to Step 3 to exit the software without running Daily Clean. If Daily Clean was already run, exit the software and skip to Step 6.
- 3 If you attempt to exit the software without performing Daily Clean, a confirmation message appears.
- 4 Select **No. Not Now** or **No. Continue to exit the software**. A warning message appears.

[Cytometer's power is on]



**[Cytometer's power is off]**

**NOTE** If you want to perform the Daily Clean before exiting the software, select **Yes. Run Daily Clean Now** or **Yes. Cancel exiting the software** and run the Daily Clean procedure. Refer to [Running Daily Clean](#).

- 5 Select **Yes** to skip the Daily Clean.



**NOTE** If you want to perform the Daily Clean before exiting the software, select **No**. Skip to Step 4 and select **Yes. Run Daily Clean Now** or **Yes. Cancel exiting the software** and run the Daily Clean procedure. Refer to [Running Daily Clean](#).

- 6 **Optional:** Turn the computer off.

- 7 **Optional:** Turn the Cytometer's main power switch off.

## Auto Shutdown [CytoFLEX LX Only]

You can set up the system to automatically shutdown the Cytometer.

To schedule an auto shutdown after acquisition, refer to Step 6 of [CHAPTER 6, Creating an Experiment](#).

To schedule an auto shutdown during Daily Clean, refer to Step 3 of [CHAPTER 11, Daily Clean \[With Plate Loader\]](#).



## Overview

---

**IMPORTANT** In addition to the information stated, never disassemble the instrument or have it repaired by unauthorized personnel. Beckman Coulter bears no responsibility for any problems arising from the unauthorized repair of the instrument.

This chapter introduces solutions to common problems. If there is a problem, follow the information in this chapter to carry out self-inspection. If the problem cannot be resolved, [contact us](#).

This chapter contains information on:

- [Precautions/Hazards](#)
- [Hazard Labels and Locations](#)
- [Disposal Precaution](#)
- [Troubleshooting Table](#)
- [Backup and Restore](#)

## Precautions/Hazards

---

### Laser Related Hazards

Beckman Coulter design and manufacture of the instrument complies with the requirements governing the use and application of a laser specified in regulatory documents issued by the:

- U.S. Department of Health and Human Services
- Center for Devices and Radiological Health (CDRH)
- International Electrotechnical Commission (IEC)

In compliance with these regulatory documents, every measure has been taken to ensure the health and safety of users and laboratory personnel from the possible dangers of laser use.

Use the instrument according to the information in the manuals.

Use controls or adjustments or performance of procedures other than those specified herein might result in hazardous radiation exposure.

To ensure your safety, the Cytometer lasers are covered with protective shields. Do not remove these shields.

No user-serviceable assemblies are accessible. Do not attempt to remove the laser or open it. The instrument has components that are dangerous to the operator. If any attempt has been made to defeat a safety feature, or if the instrument fails to perform as described in its manuals, disconnect the power and [contact us](#).

### Laser Beam Hazards

The CytoFLEX Platform flow cytometer can be configured with up to 6 solid-state diode lasers that are capable of producing laser light at the following levels:

- 355 nm, 20 mW solid-state diode laser
- 375 nm, 60 mW solid-state diode laser
- 405 nm, 80 mW solid-state diode laser
- 488 nm, 50 mW solid-state diode laser
- 561 nm, 30 mW solid-state diode laser
- 638 nm, 50 mW solid-state diode laser
- 808 nm, 60 mW solid-state diode laser

A laser beam is a unique light source that shows characteristics different from conventional light sources. The safe use of the laser depends upon familiarity with the instrument and the properties of coherent, intense beams of light.



**Risk of personal injury. The laser beam can cause eye damage if viewed either directly or indirectly from reflective surfaces (such as a mirror or shiny metallic surfaces). To prevent eye damage, avoid direct exposure to the laser beam. Do not view it directly or with optical instruments.**

Indirect contact with the laser beam from reflective surfaces (such as jewelry or a screwdriver) is called specular reflection and might also cause damage.

For these reasons, it is important to:

- Limit access to the Cytometer to trained and experienced personnel.
- Never attempt to remove a shield housing a laser.
- Never remove a warning label.
- [Contact us](#) if a label is missing or unclear.

## Laser Warning Labels



**Risk of personal injury from radiation exposure. Never remove the shield surrounding a laser. Never remove covers.**

CDRH-approved and IEC compliant labels are also placed near or on those covers that when removed might expose laser radiation. If necessary, a cover with a CDRH-approved or IEC compliant label must be removed by a qualified Beckman Coulter Representative only.

Refer to the following figures for the locations of the CDRH-approved and IEC compliant labels:

See [Figure 10.1](#) and [Figure 10.2](#) for the Laser Warning Label on the Cytometer optical bench.

See [Figure 10.3](#) and [Figure 10.4](#) for the Laser Warning Label on the optical bench (located inside the Cytometer).

See [Figure 10.6](#) and [Figure 10.7](#) for the Laser Warning Labels on the Cytometer Back Cover.

The laser product is classified as CLASS 1 when all protective measures are in place. This product complies with 21 CFR Parts 1040.10 and 1040.11 as well as EN60825-1. See [Figure 10.1](#).

**Figure 10.1** Laser Warning Label on the Laser Optical Bench [CytoFLEX]

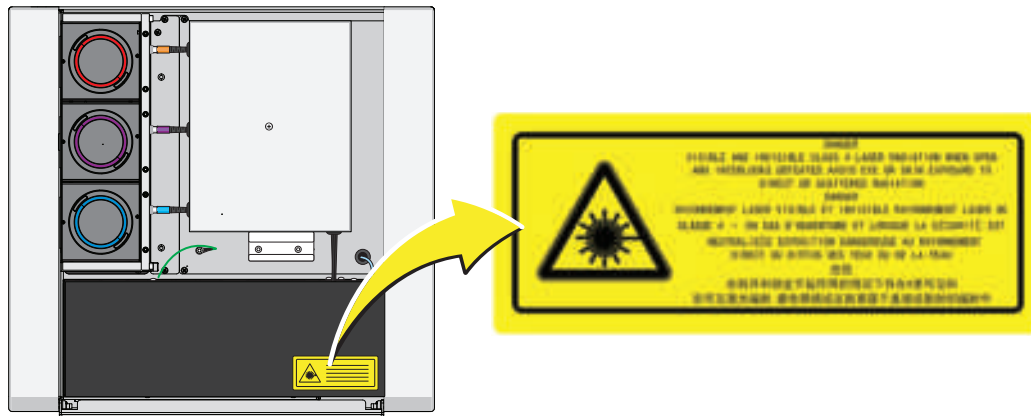


Figure 10.2 Laser Warning Label on the Laser Optical Bench [CytoFLEX LX]

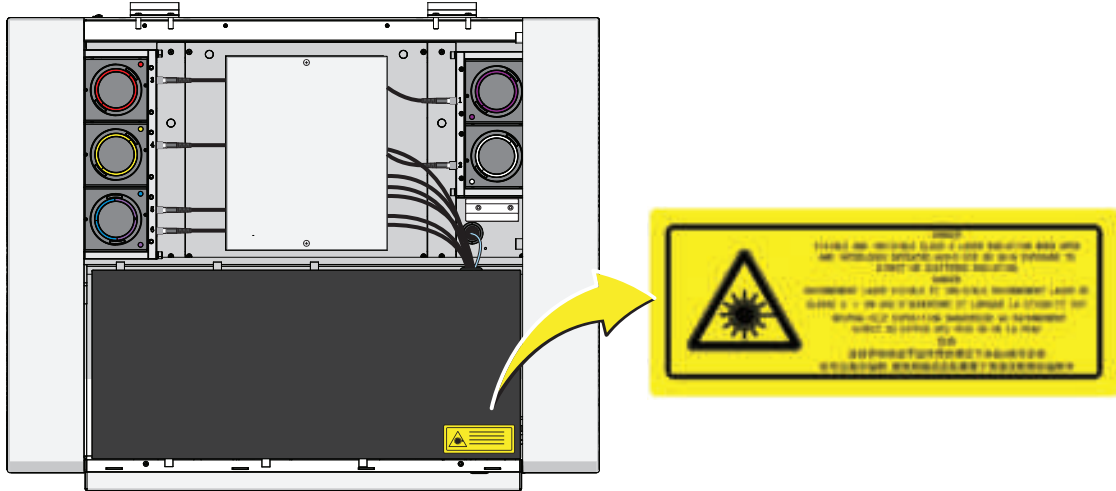


Figure 10.3 Laser Warning Label within the Optical Bench (Located Inside the Cytometer) [CytoFLEX and CytoFLEX S]

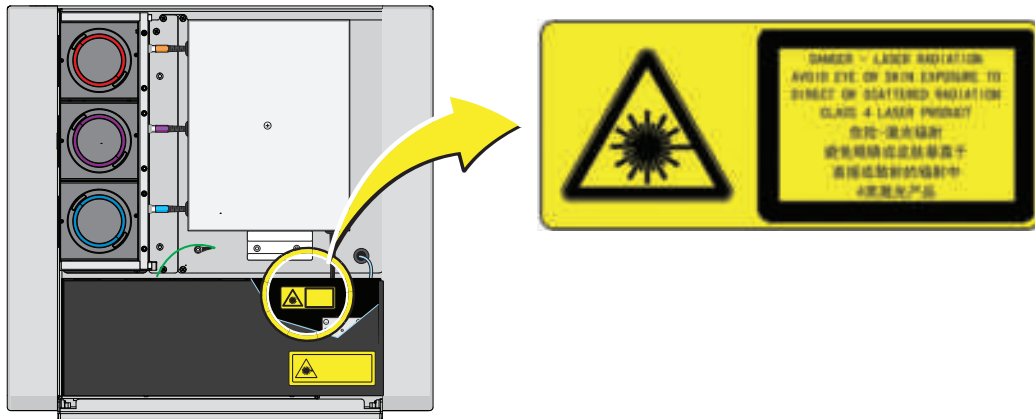
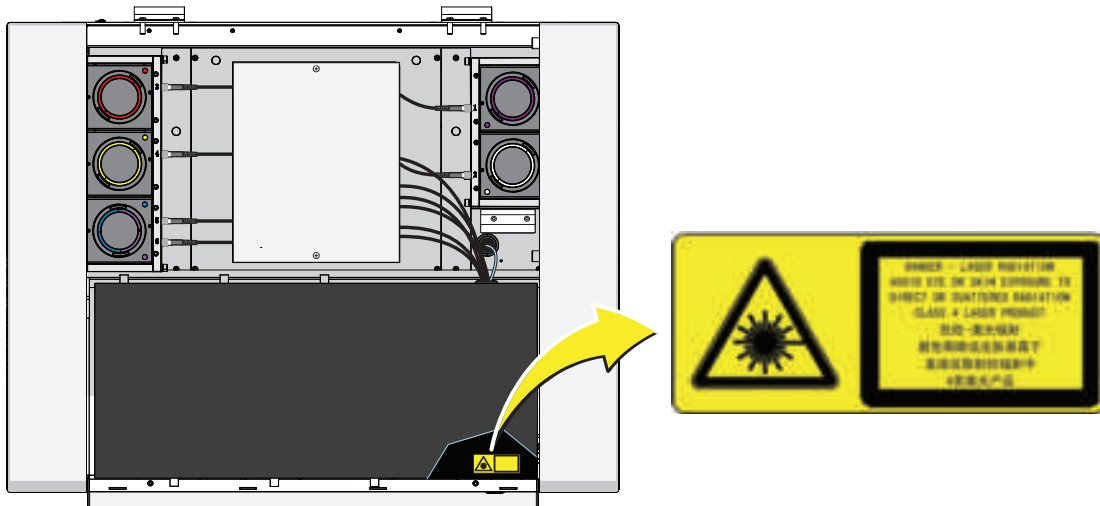
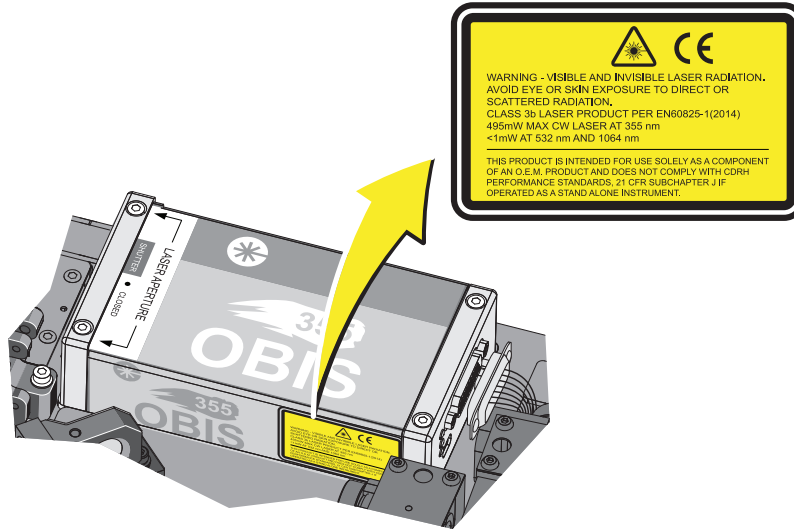


Figure 10.4 Laser Warning Label within the Optical Bench (Located Inside the Cytometer) [CytoFLEX LX]



**Figure 10.5** Laser Warning Label on the 355-nm Laser [CytoFLEX LX]



**Figure 10.6** Laser Warning Labels on the Cytometer Back Cover [CytoFLEX and CytoFLEX S]

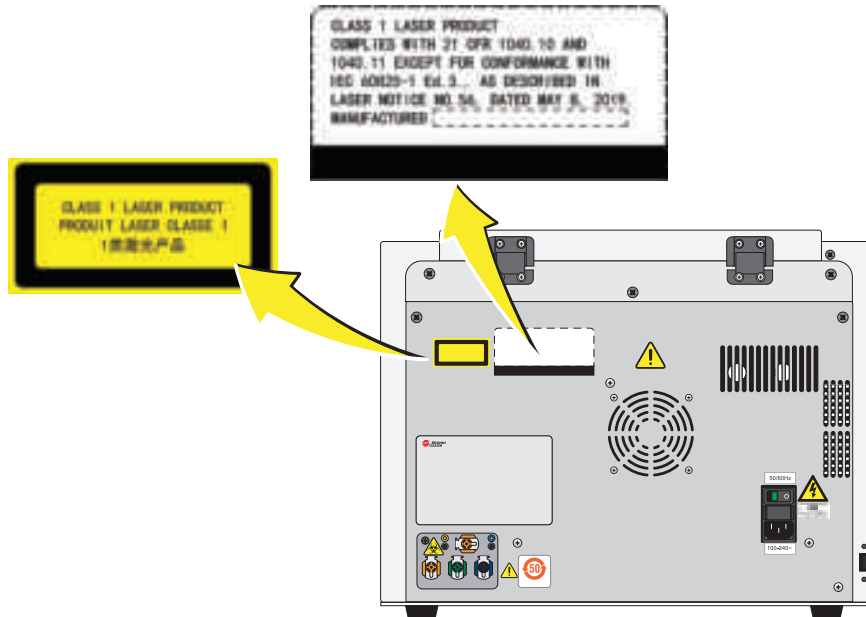
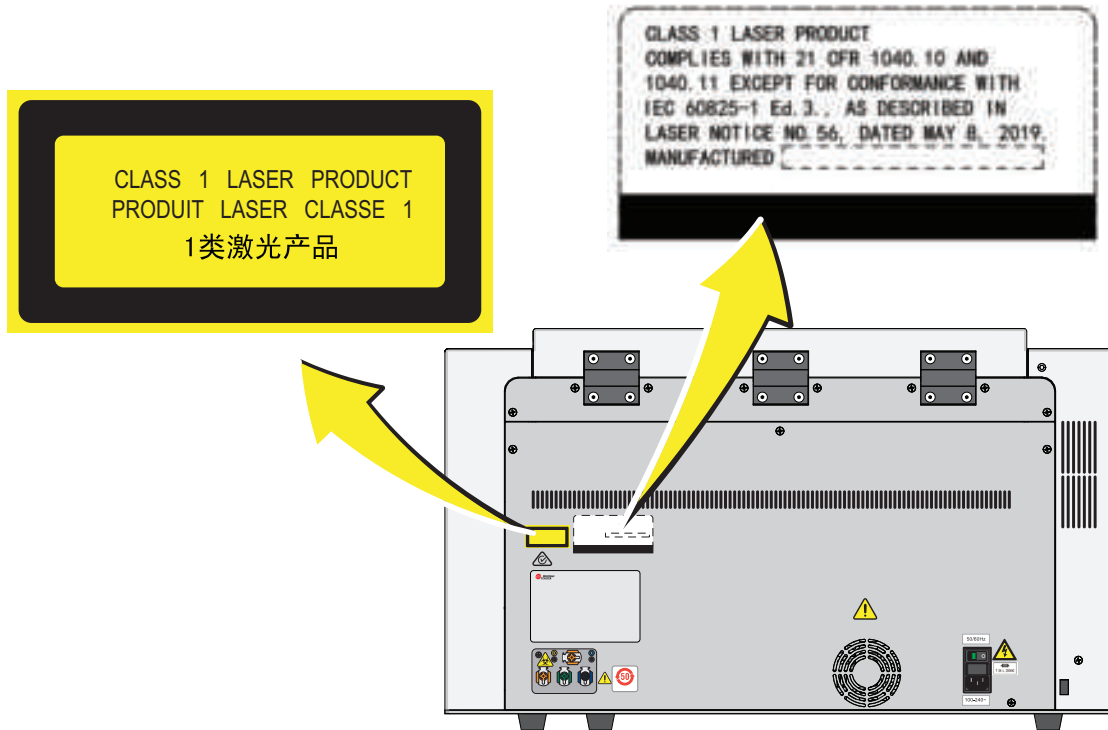


Figure 10.7 Laser Warning Labels on the Cytometer Back Cover [CytoFLEX LX]



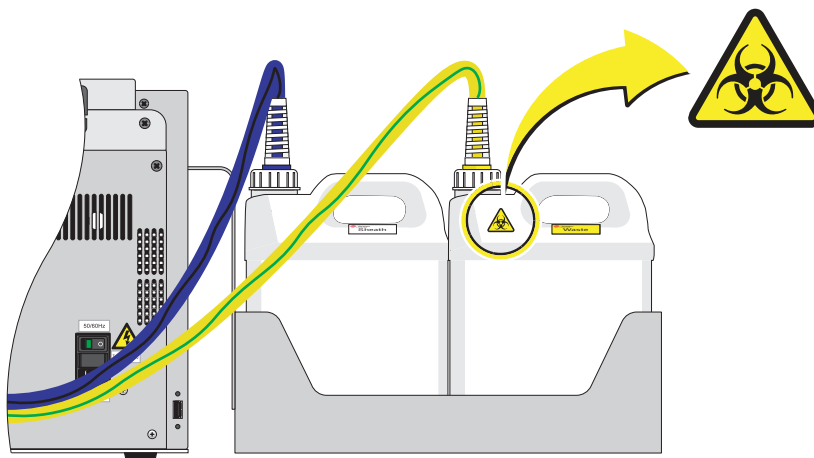
## Hazard Labels and Locations

Carefully read the hazard warning labels on the instrument. The hazard labels are located on the instrument as indicated.

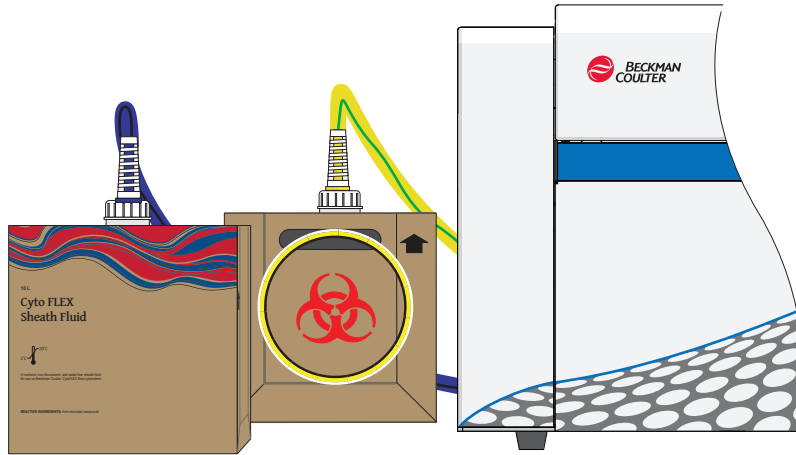
**NOTE** If a label is missing or unclear, [contact us](#).

## Biohazard Label and Location

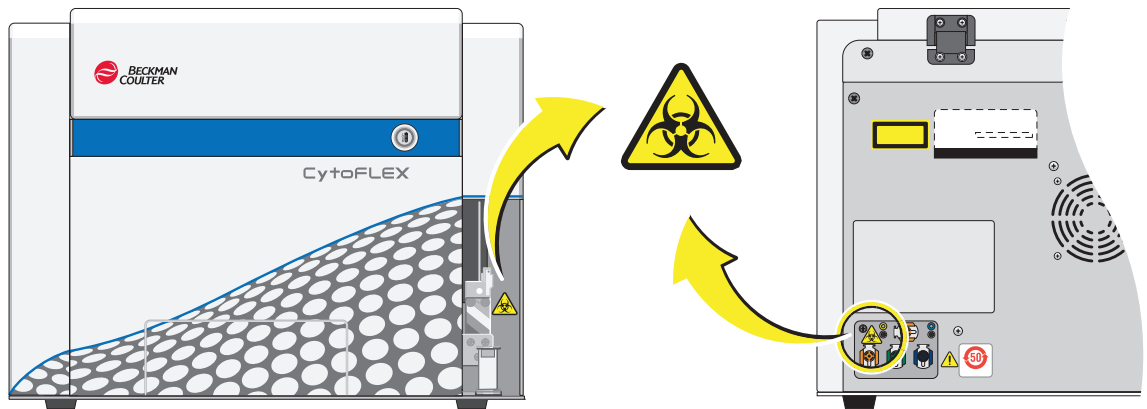
Figure 10.8 Biohazard Label on the 4 L Fluid Containers



**Figure 10.9** Biohazard Label on the 10 L Fluid Cubitainers

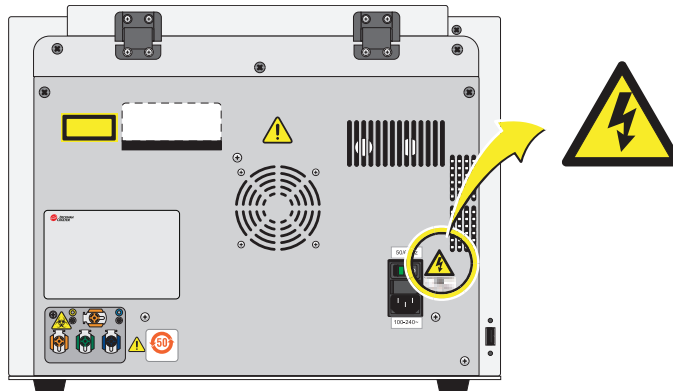


**Figure 10.10** Biohazard Label Located in the Sample Station and on the Back of the Cytometer [CytoFLEX Shown]



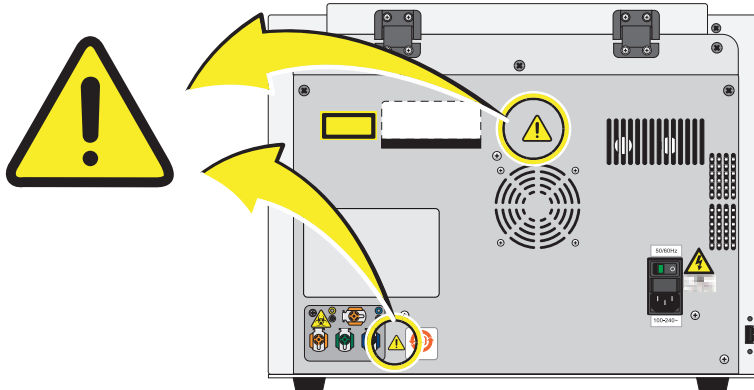
## Electrical Shock Hazard Label and Location

**Figure 10.11** Electrical Shock Hazard Label by the Power Switch [CytoFLEX or CytoFLEX S]



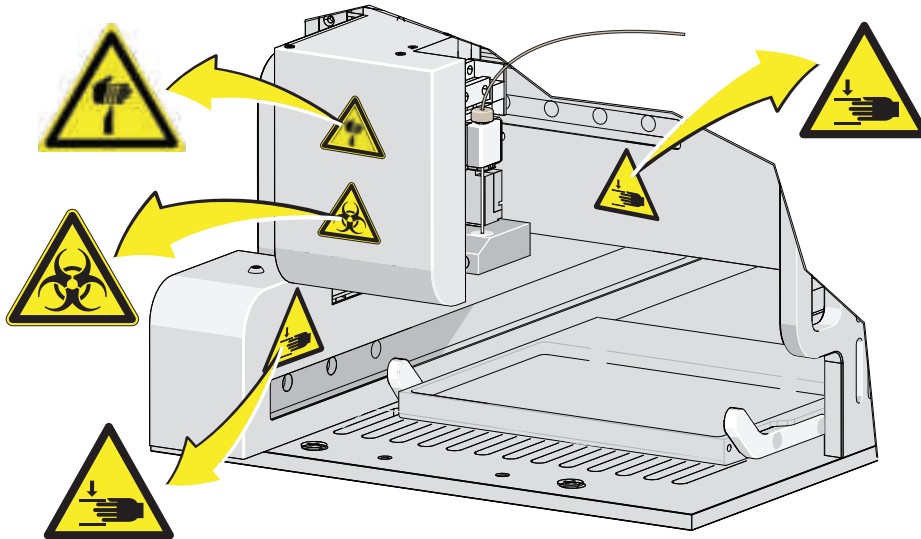
## Caution Labels and Location

Figure 10.12 Caution Labels [CytoFLEX or CytoFLEX S]



## Plate Loader Hazard Labels and Location

Figure 10.13 Plate Loader Hazard Labels



## Disposal Precaution



### **WARNING**

**Risk of biohazardous contamination if you have skin contact with the waste container, its contents, and its associated tubing. The waste container and its associated tubing could contain residual biological material and must be handled with care. Clean up spills immediately. Dispose of the contents of the waste container in accordance with your local regulations and acceptable laboratory procedures.**

Use universal precautions when working with pathogenic materials. Means must be available to decontaminate the instrument and to dispose of biohazardous waste.


## Troubleshooting Table

Table 10.1 lists problems that you could encounter while running the CytoFLEX flow cytometer, the probable causes of each problem, and the corrective actions. These problems are listed alphabetically in the Index, under the primary entry “troubleshooting”.

**Table 10.1** Troubleshooting

Problem	Probable Cause	Corrective Action
The Cytometer cannot be turned on.	<ul style="list-style-type: none"> <li>The instrument is turned off in the Cytometer menu. [CytoFLEX LX]</li> <li>The power switch is in the off position and the Turn On selection will not function in the Cytometer menu. [CytoFLEX LX]</li> <li>The power cable is not securely connected.</li> <li>The fuse is blown.</li> </ul>	<ol style="list-style-type: none"> <li>Ensure the power switch is in the on position on the back of the Cytometer. [CytoFLEX LX]</li> <li>Select <b>Turn On</b> in the Cytometer menu. [CytoFLEX LX]</li> <li>Ensure that the power cable is securely connected to the back of the Cytometer.</li> <li>Replace the fuse. Refer to <a href="#">CHAPTER 12, Replacing the Fuse</a>.</li> <li>If the problem persists, <a href="#">contact us</a>.</li> </ol>
The Workstation cannot be turned on.	<ul style="list-style-type: none"> <li>The power cable is not securely connected.</li> <li>The Workstation was restarted too fast.</li> </ul>	<ol style="list-style-type: none"> <li>Ensure that the power cable is securely connected to the back of the Cytometer.</li> <li>Unplug the power cable. Wait 10 seconds, then plug the power cable back in. Then, restart the computer.</li> <li>If the problem persists, <a href="#">contact us</a>.</li> </ol>

**Table 10.1** Troubleshooting (*Continued*)

Problem	Probable Cause	Corrective Action
<p>The connection indicator light in the lower left corner of the software screen is red and displays <i>Disconnected</i> and <i>Error</i>.</p>	<ul style="list-style-type: none"> <li>• Data connection error</li> <li>• The Cytometer is not turned on.</li> <li>• The Cytometer's power cable is disconnected.</li> </ul>	<ol style="list-style-type: none"> <li>1. Ensure that the USB data cable is securely connected to the back of the Cytometer and the back of the Workstation. Refer to <a href="#">Figure 1.22</a>.</li> <li>2. Restart the software. Restart the Workstation. Refer to <a href="#">CHAPTER 4, Initializing the Instrument</a>.</li> <li>3. Turn on the Cytometer using the power switch on the back of the instrument.</li> <li>4. Verify that the power cable is securely connected to the back of the Cytometer.</li> <li>5. If the problem persists, <a href="#">contact us</a>.</li> </ol>
<p>The alarm does not sound when the waste container is full or the sheath fluid container is low and the software status display is red.</p>	<ul style="list-style-type: none"> <li>• The alarm is not working.</li> <li>• Instrument data connection error.</li> <li>• The sheath fluid/waste harness float is restricted.</li> <li>• The sheath fluid/waste harnesses have been secured on the wrong container.</li> </ul>	<ol style="list-style-type: none"> <li>1. Ensure the sheath fluid/waste harnesses are secured to the correct container.</li> <li>2. Ensure that the USB data cable is securely connected to the back of the Cytometer and the back of the Workstation. Refer to <a href="#">Figure 1.22</a>.</li> <li>3. Restart the Workstation. Refer to <a href="#">CHAPTER 4, Initializing the Instrument</a>.</li> <li>4. Restart the software.</li> </ol> <div style="border: 1px solid black; background-color: #ffcc00; padding: 5px; margin: 10px 0;"> <p> <b>WARNING</b></p> </div> <p><b>Risk of biohazardous contamination if you have skin contact with the waste container, its contents, and its associated tubing. The waste container and its associated tubing could contain residual biological material and must be handled with care. Clean up spills immediately. Dispose of the contents of the waste container in accordance with your local regulations and acceptable laboratory procedures.</b></p> <ol style="list-style-type: none"> <li>5. Verify that the float of the sensor in the sheath fluid/waste container moves freely.</li> <li>6. Replace the sheath fluid/waste harness. Refer to <a href="#">CHAPTER 12, Replacing the Sheath Fluid Harness and/or Waste Harness</a>.</li> <li>7. If the problem persists, <a href="#">contact us</a>.</li> </ol>

**Table 10.1** Troubleshooting (Continued)

Problem	Probable Cause	Corrective Action
<p>The fluid status information displays red for <i>Sheath</i> and/or <i>Waste</i> even though the sheath fluid container is full and the waste container is empty.</p>	<ul style="list-style-type: none"> <li>• Instrument data connection error.</li> <li>• The sensor connection is not working properly.</li> <li>• The sensor does not work properly.</li> <li>• The sheath fluid/waste harnesses have been secured on the wrong container.</li> </ul>	<ol style="list-style-type: none"> <li>1. Ensure the sheath fluid/waste harnesses are secured to the correct container.</li> <li>2. Ensure that the USB data cable is securely connected to the back of the Cytometer and the back of the Workstation. Refer to <a href="#">Figure 1.22</a>.</li> <li>3. Restart the software.</li> <li>4. Ensure the sheath fluid harness and/or the waste harness are properly connected.</li> <li>5. Verify that the float of the sensor in the sheath fluid container and/or waste container moves freely.</li> <li>6. Replace the sheath fluid harness and/or the waste harness. Refer to <a href="#">CHAPTER 12, Replacing the Sheath Fluid Harness and/or Waste Harness</a>.</li> <li>7. If the problem persists, <a href="#">contact us</a>.</li> </ol>
<p>The sample tube holder cannot move up and down automatically.</p>	<p>The setting is incorrect.</p>	<ol style="list-style-type: none"> <li>1. Ensure that the sample injection mode in the software is in Semi-Automatic Injection mode. Refer to <a href="#">CHAPTER 4, Selecting the Proper Sample Injection Mode</a>.</li> <li>2. If the problem persists, <a href="#">contact us</a>.</li> </ol>
<p>The sample flow rate is unstable.</p>	<ul style="list-style-type: none"> <li>• The sample probe is clogged.</li> <li>• The sample contains aggregates or clumps.</li> <li>• There are air bubbles in the flow cell.</li> <li>• The sample peristaltic pump tubing is aged.</li> <li>• The sample peristaltic pump tubing is not properly connected.</li> </ul>	<ol style="list-style-type: none"> <li>1. Run Prime. Refer to <a href="#">CHAPTER 12, Priming the Flow Cell</a>.</li> <li>2. Run Daily Clean. Refer to <a href="#">CHAPTER 11, Daily Clean</a>.</li> <li>3. Clean the sample probe. Refer to <a href="#">CHAPTER 11, Cleaning the Sample Probe</a>.</li> <li>4. Filter the sample using an appropriately sized mesh aperture filter.</li> <li>5. Ensure that the sample tubing is properly connected. Refer to <a href="#">CHAPTER 12, Replacing the Sample Probe and/or the Sample Peristaltic Pump Tubing</a>.</li> <li>6. Replace the sample probe and sample peristaltic pump tubing. Refer to <a href="#">CHAPTER 12, Replacing the Sample Probe and/or the Sample Peristaltic Pump Tubing</a>.</li> <li>7. If the problem persists, <a href="#">contact us</a>.</li> </ol>


**Table 10.1** Troubleshooting (*Continued*)

Problem	Probable Cause	Corrective Action
The sampling flow rate is too fast.	<ul style="list-style-type: none"> <li>• The threshold setting is too low.</li> <li>• The sample concentration is too high.</li> <li>• There are too many sample fragments.</li> <li>• The sheath fluid filter is clogged.</li> <li>• The sample flow rate requires calibration.</li> </ul>	<ol style="list-style-type: none"> <li>1. Use the manual threshold setting to increase the threshold. Refer to <a href="#">CHAPTER 6, Adjusting the Threshold</a>.</li> <li>2. Calibrate the sample flow rate. Refer to <a href="#">CHAPTER 12, Calibrating the Sample Flow Rate</a> or <a href="#">CHAPTER 12, Calibrating the Sample Flow Rate [With Plate Loader]</a>.</li> <li>3. Dilute the sample and adjust the concentration to approximately 10<sup>6</sup>/mL.</li> <li>4. Filter the sample using an appropriately sized mesh aperture filter.</li> <li>5. Restain the sample.</li> <li>6. Replace the Sheath Fluid Filter. Refer to <a href="#">CHAPTER 12, Replacing the Sheath Fluid Filter</a>.</li> <li>7. If the problem persists, <a href="#">contact us</a>.</li> </ol>
Laser power is low.	Communication error	<ol style="list-style-type: none"> <li>1. Reinitialize. Refer to <a href="#">CHAPTER 4, Initializing the Instrument</a>.</li> <li>2. Restart the Cytometer.</li> <li>3. If the problem persists, <a href="#">contact us</a>.</li> </ol>
Populations are drifting.	<ul style="list-style-type: none"> <li>• Air bubbles are in the flow cell.</li> <li>• Air bubbles are in the system.</li> <li>• The sheath fluid harness float is restricted.</li> </ul>	<ol style="list-style-type: none"> <li>1. Run Prime. Refer to <a href="#">CHAPTER 12, Priming the Flow Cell</a>.</li> <li>2. Ensure that the sheath fluid harness and/or waste harness is not kinked.</li> <li>3. Ensure that the sheath fluid harness and/or waste harness is securely connected.</li> <li>4. Run Prime. Refer to <a href="#">CHAPTER 12, Priming the Flow Cell</a>.</li> <li>5. Verify that the float of the sensor in the sheath fluid container moves freely.</li> <li>6. Replace the sheath fluid harness. Refer to <a href="#">CHAPTER 12, Replacing the Sheath Fluid Harness and/or Waste Harness</a>.</li> <li>7. If the problem persists, <a href="#">contact us</a>.</li> </ol>
Population amplitude is decreasing and CV values are increasing.	<ul style="list-style-type: none"> <li>• Air bubbles are in the flow cell.</li> <li>• The flow cell is dirty.</li> <li>• The sheath fluid harness float is restricted.</li> </ul>	<ol style="list-style-type: none"> <li>1. Run Prime. Refer to <a href="#">CHAPTER 12, Priming the Flow Cell</a>.</li> <li>2. Run the Deep Clean procedure. Refer to <a href="#">CHAPTER 11, Deep Clean Procedure</a>.</li> <li>3. Verify that the float of the sensor in the sheath fluid container moves freely.</li> <li>4. Replace the sheath fluid harness. Refer to <a href="#">CHAPTER 12, Replacing the Sheath Fluid Harness and/or Waste Harness</a>.</li> <li>5. If the problem persists, <a href="#">contact us</a>.</li> </ol>



**Table 10.1** Troubleshooting (Continued)

Problem	Probable Cause	Corrective Action
The laser delay values are out of range.	<ul style="list-style-type: none"> <li>• Air bubbles are in the flow cell.</li> <li>• Air bubbles are in the system.</li> <li>• The sheath fluid harness float is restricted.</li> </ul>	<ol style="list-style-type: none"> <li>1. Run Prime. Refer to <a href="#">CHAPTER 12, Priming the Flow Cell</a>.</li> <li>2. Ensure that the sheath fluid harness and/or waste harness is not kinked.</li> <li>3. Ensure that the sheath fluid harness and/or waste harness is securely connected.</li> <li>4. Verify that the float of the sensor in the sheath fluid container moves freely.</li> <li>5. Replace the sheath fluid harness. Refer to <a href="#">CHAPTER 12, Replacing the Sheath Fluid Harness and/or Waste Harness</a>.</li> <li>6. If the problem persists, <a href="#">contact us</a>.</li> </ol>
No data acquisition.	<ul style="list-style-type: none"> <li>• The threshold setting is too high.</li> <li>• The gain setting is too low.</li> <li>• Sheath fluid flow is insufficient.</li> <li>• Laser power is insufficient.</li> <li>• The sample probe is clogged.</li> </ul>	<ol style="list-style-type: none"> <li>1. Decrease the threshold setting. Refer to <a href="#">CHAPTER 6, Adjusting the Threshold</a>.</li> <li>2. Increase the gain setting. Refer to <a href="#">CHAPTER 6, Adjusting the Gain</a>.</li> <li>3. Ensure that the sheath fluid harness and/or waste harness is not kinked.</li> <li>4. Ensure that the sheath fluid harness and/or waste harness is securely connected.</li> <li>5. Run Prime. Refer to <a href="#">CHAPTER 12, Priming the Flow Cell</a>.</li> <li>6. Reinitialize. Refer to <a href="#">CHAPTER 4, Initializing the Instrument</a>.</li> <li>7. Restart the Cytometer.</li> <li>8. Verify that your sample does not have excessive debris. If it does:               <ol style="list-style-type: none"> <li>a. Filter the sample using an appropriately sized mesh aperture filter.</li> <li>b. Restain the sample.</li> </ol> </li> <li>9. Clean the sample probe. Refer to <a href="#">CHAPTER 11, Cleaning the Sample Probe</a>.</li> <li>10. Replace the sample probe and the sample peristaltic pump tubing. Refer to <a href="#">CHAPTER 12, Replacing the Sample Probe and/or the Sample Peristaltic Pump Tubing</a>.</li> <li>11. If the problem persists, <a href="#">contact us</a>.</li> </ol>
Data populations are normal on one laser, but too low on another laser.	The laser delay setting is incorrect.	<ol style="list-style-type: none"> <li>1. Ensure that the laser delay is set correctly. Refer to <a href="#">CHAPTER 12, Setting Laser Delay</a>.</li> <li>2. If the problem persists, <a href="#">contact us</a></li> </ol>

**Table 10.1** Troubleshooting (*Continued*)

Problem	Probable Cause	Corrective Action
Data populations are not where they are expected.	<ul style="list-style-type: none"> <li>• The detector configuration setting is incorrect.</li> <li>• The optical filter is not placed correctly.</li> <li>• QC was not completed.</li> <li>• Gain and threshold is not set correctly.</li> </ul>	<ol style="list-style-type: none"> <li>1. Ensure that the detector configuration is set correctly. Refer to <a href="#">CHAPTER 6, Verifying, Selecting, Editing, and Creating Detector Configuration</a>.</li> <li>2. Ensure that the position of the optical filter in the WDM matches the detector configuration setting. Refer to <a href="#">CHAPTER 6, Verifying, Selecting, Editing, and Creating Detector Configuration</a>.</li> <li>3. Ensure that the optical filter is installed correctly. Refer to <a href="#">CHAPTER 12, Replacing the Optical Filter</a>.</li> <li>4. Follow the QC procedure. Refer to <a href="#">CHAPTER 5, Instrument Quality Control and Standardization</a>.</li> <li>5. Review the gain and threshold settings. Refer to <a href="#">CHAPTER 6, Adjusting the Gain</a> and <a href="#">CHAPTER 6, Adjusting the Threshold</a>.</li> <li>6. Review the display ranges. Refer to <a href="#">CHAPTER 6, Creating Plots and Gates</a>.</li> <li>7. If the problem persists, <a href="#">contact us</a>.</li> </ol>
No changes occurred after manually adjusting compensation settings.	Compensation was applied to the wrong channel.	<p>Ensure that the adjustment is applied to the correct primary and secondary channels in the compensation matrix.</p> <p>Or</p> <p>Select  to modify compensation in the desired plot.</p>
The calculation of the automatic compensation experiment is incorrect.	<ul style="list-style-type: none"> <li>• Erroneous data acquisition.</li> <li>• The gate is not set on the appropriate population.</li> <li>• The events of the acquired cells are too low.</li> <li>• The mean fluorescence of the positive cells is too weak.</li> </ul>	<ol style="list-style-type: none"> <li>1. Ensure that the corresponding negative control tube and the individual positive tube acquired are from the same sample type.</li> <li>2. Ensure that the single colors collected correspond to the correct tube name.</li> <li>3. Ensure that the gate in the FSC/SSC plot encloses the correct sample population.</li> <li>4. Ensure that the positive gate in each tube is correctly placed.</li> <li>5. Modify the events to record to ensure that enough events are collected for the data population.</li> <li>6. Select samples with a stronger positive signal as the positive control.</li> </ol> <p>Or</p> <p>Use dedicated compensation beads such as VersaComp Antibody Capture Beads</p>

**Table 10.1** Troubleshooting (Continued)

Problem	Probable Cause	Corrective Action
<p>The sample is flowing, but no signal appears in the plot.</p>	<ul style="list-style-type: none"> <li>• The signal is outside of the display range.</li> <li>• The parent gate is not positioned properly and does not contain events.</li> <li>• The population color setting is too light.</li> <li>• The threshold is too high.</li> </ul>	<ol style="list-style-type: none"> <li>1. Use either  or  to modify the display range. Or Right-click the plot and select <b>Property</b>. The Plot Property window appears. Select <b>Fit with sample</b>.</li> <li>2. Ensure that the parent gate is gated correctly.</li> <li>3. Change the display color.</li> <li>4. Move the sample above the threshold using one of the following methods: <ul style="list-style-type: none"> <li>• Decrease the threshold setting. Refer to <a href="#">CHAPTER 6, Adjusting the Threshold</a>.</li> <li>• Increase the gain setting. Refer to <a href="#">CHAPTER 6, Adjusting the Gain</a>.</li> </ul> </li> </ol>
<p>The concentration calculation is incorrect.</p>	<ul style="list-style-type: none"> <li>• The sample concentration is not within the specified range.</li> <li>• The sample settled.</li> <li>• The sample flow rate is too fast.</li> <li>• The sample volume analyzed is too low.</li> <li>• The cell population is not detected.</li> </ul>	<ol style="list-style-type: none"> <li>1. Ensure that the pipette used in sample processing is calibrated.</li> <li>2. Verify that the concentration of the sample is between <math>2 \times 10^4</math>-<math>10^7</math> events/mL.</li> <li>3. Vortex the sample before loading and verify that the sample is evenly mixed before loading the sample.  <b>NOTE</b> An excessively long sample loading time leads to sample settlement.</li> <li>4. Ensure that the sample flow rate does not exceed 10,000 events/second.</li> <li>5. Adjust the threshold to remove sample debris.</li> <li>6. Ensure that the sample volume analyzed exceeds 10 <math>\mu</math>L.</li> <li>7. Ensure that the following are correct: <ul style="list-style-type: none"> <li>• Gain. Refer to <a href="#">CHAPTER 6, Adjusting the Gain</a>.</li> <li>• Threshold. Refer to <a href="#">CHAPTER 6, Adjusting the Threshold</a>.</li> <li>• Compensation settings. Refer to <a href="#">CHAPTER 7, Compensation</a></li> </ul> </li> <li>8. Ensure that the gating and population hierarchy are correct.</li> </ol>

**Table 10.1** Troubleshooting (*Continued*)

Problem	Probable Cause	Corrective Action
The sample probe is too low.	The sample probe is not securely connected.	<ol style="list-style-type: none"> <li>1. Ensure that the sample probe is securely connected to the sample peristaltic pump tubing. Refer to <a href="#">CHAPTER 12, Replacing the Sample Probe and/or the Sample Peristaltic Pump Tubing</a>.</li> <li>2. Ensure the sample pump cover is securely fastened.</li> <li>3. If the problem persists, <a href="#">contact us</a>.</li> </ol>
The wash station drips during backflush.	<ul style="list-style-type: none"> <li>• The sample probe is not securely connected.</li> <li>• The wash station height adjustment is not correct.</li> </ul>	<ol style="list-style-type: none"> <li>1. Ensure that the sample probe is securely connected to the sample peristaltic pump tubing. Refer to <a href="#">CHAPTER 12, Replacing the Sample Probe and/or the Sample Peristaltic Pump Tubing</a>.</li> <li>2. Ensure the sample pump cover is securely fastened.</li> <li>3. If the problem persists, <a href="#">contact us</a>.</li> </ol>
The mixer is not functioning.	<ul style="list-style-type: none"> <li>• Sample mixing is disabled in the software.</li> <li>• The mixer motor is defective.</li> </ul>	<ol style="list-style-type: none"> <li>1. Ensure sample mixing is enabled in the software. Refer to <a href="#">CHAPTER 12, Changing Sample Mixing and Backflush Settings</a>.</li> <li>2. If the problem persists, <a href="#">contact us</a>.</li> </ol>
Instrument operations cannot be performed in the Acquisition screen.	<ul style="list-style-type: none"> <li>• The instrument is in standby mode.</li> <li>• The software is frozen.</li> <li>• Data connection error.</li> </ul>	<ol style="list-style-type: none"> <li>1. Select <b>Initialize</b>.</li> <li>2. Ensure that the power switch to the Cytometer is turned on.</li> <li>3. Restart the software.</li> <li>4. Restart the Workstation.</li> <li>5. Ensure that the USB data cable is securely connected to the back of the Cytometer and the back of the Workstation. Refer to <a href="#">Figure 1.22</a>.</li> <li>6. If the problem persists, <a href="#">contact us</a>.</li> </ol>
Software installation fails.	Multiple issues.	<a href="#">Contact us</a> .

**Table 10.1** Troubleshooting (Continued)

Problem	Probable Cause	Corrective Action
<p>QC aborted due to low event rate.</p>	<ul style="list-style-type: none"> <li>• The diluted CytoFLEX Daily QC Fluorospheres or CytoFLEX Daily IR QC Fluorospheres concentration is too low.</li> <li>• The sample contains aggregates or clumps.</li> <li>• The sample probe is clogged.</li> <li>• The sample line is clogged.</li> </ul>	<ol style="list-style-type: none"> <li>1. Add 1 drop of CytoFLEX Daily QC Fluorospheres or CytoFLEX Daily IR QC Fluorospheres to the QC solution. Then, rerun QC.</li> <li>2. Prepare a new sample of QC Fluorospheres. Then, rerun QC.                             <p style="margin-left: 20px;"><b>NOTE</b> Mix the fluorospheres dropper bottle thoroughly before dispensing it into a tube.</p> </li> <li>3. Reload the target value file. Refer to <a href="#">CHAPTER 5, Importing Lot-Specific Target Values</a>. Then, rerun QC.</li> <li>4. Clean the sample probe. Refer to <a href="#">CHAPTER 11, Cleaning the Sample Probe</a>. Then, rerun QC.</li> <li>5. Run Prime. Refer to <a href="#">CHAPTER 12, Priming the Flow Cell</a>. Then, rerun QC.</li> <li>6. Run Daily Clean. Refer to <a href="#">CHAPTER 11, Daily Clean</a>. Then, rerun QC.</li> <li>7. Replace the sample probe and sample peristaltic pump tubing. Refer to <a href="#">CHAPTER 12, Replacing the Sample Probe and/or the Sample Peristaltic Pump Tubing</a>. Then, rerun QC.</li> <li>8. If problem persists, <a href="#">contact us</a>.</li> </ol>

**Table 10.1** Troubleshooting (*Continued*)

Problem	Probable Cause	Corrective Action
QC failed.	<ul style="list-style-type: none"> <li>• The sheath fluid container and the waste container are not on the same level as the Cytometer.</li> <li>• The median fluorescence fails to meet the target specification.</li> <li>• The QC gain value does not meet the target gain specifications.</li> <li>• The laser delay settings are too high.</li> <li>• rCV fails specifications.</li> </ul>	<ol style="list-style-type: none"> <li>1. Ensure the sheath fluid container and the waste container are on the same level as the Cytometer.</li> <li>2. Rerun QC. Refer to <a href="#">CHAPTER 5, Instrument Quality Control and Standardization</a>.</li> <li>3. Run Prime. Refer to <a href="#">CHAPTER 12, Priming the Flow Cell</a>. Then, rerun QC.</li> <li>4. Prime the sheath fluid filter with sheath fluid as follows, then rerun QC.             <ol style="list-style-type: none"> <li>a. Remove the vent cap from the sheath fluid filter.</li> <li>b. Ensure that the instrument is in Standby.</li> <li>c. At the Workstation, select <b>Cytometer &gt; Prime</b>.</li> </ol> <p><b>IMPORTANT</b> If the vent cap is not reinstalled as soon as the sheath fluid approaches the vent port, the sheath fluid will overflow.</p> <ol style="list-style-type: none"> <li>d. Wait until the sheath fluid approaches the vent port in the sheath fluid filter, then immediately reinstall the vent cap to avoid overflow.</li> </ol> </li> <li>5. Run Daily Clean. Refer to <a href="#">CHAPTER 11, Daily Clean</a>. Then, rerun QC.</li> <li>6. Run Deep Clean. Refer to <a href="#">CHAPTER 11, Deep Clean Procedure</a>. Then, rerun QC.</li> <li>7. If the problem persists, <a href="#">contact us</a>.</li> </ol>

**Table 10.2** Troubleshooting [With Plate Loader]

Problem	Probable Cause	Corrective Action
The sample probe comes in contact with the bottom of the well plate.	<ul style="list-style-type: none"> <li>• Incorrect plate type selected.</li> <li>• The plate or plate holder is installed incorrectly.</li> <li>• The sample probe sampling position is not calibrated.</li> </ul>	<ol style="list-style-type: none"> <li>1. Verify that the correct plate type is selected in the Plate window.</li> <li>2. Ensure the plate and the plate holder are installed correctly. Refer to <a href="#">CHAPTER 12, Replacing the Plate Holder [With Plate Loader]</a>.</li> <li>3. Calibrate the sample probe sampling position. Refer to <a href="#">CHAPTER 12, Calibrating the Plate Position [With Plate Loader]</a>.</li> </ol>
The dead volume of the plate wells are high.	<ul style="list-style-type: none"> <li>• Incorrect plate type selected.</li> <li>• The sample probe sampling position is not calibrated.</li> </ul>	<ol style="list-style-type: none"> <li>1. Verify that the correct plate type is selected in the Plate window.</li> <li>2. Calibrate the sample probe sampling position. Refer to <a href="#">CHAPTER 12, Calibrating the Plate Position [With Plate Loader]</a>.</li> </ol>
Mixing does not sufficiently suspend the sample particles.	<ul style="list-style-type: none"> <li>• Incorrect plate type selected.</li> <li>• Incorrect sample mixing setting.</li> <li>• The sample probe sampling position is not calibrated.</li> </ul>	<ol style="list-style-type: none"> <li>1. Verify that the correct plate type is selected in the Plate window.</li> <li>2. Verify the sample mixing duration in the Plate window.</li> <li>3. Calibrate the sample probe sampling position. Refer to <a href="#">CHAPTER 12, Calibrating the Plate Position [With Plate Loader]</a>.</li> </ol>
Gain is over 3,000 and default gain settings are needed.	Corrupt/incorrect configuration file.	Reload the configuration file. Refer to <a href="#">APPENDIX A, Installing the Instrument Configuration File</a> .
The configuration file does not match the instrument.	Corrupt/incorrect configuration file.	<ol style="list-style-type: none"> <li>1. Verify the correct configuration file is installed.</li> <li>2. Reload the configuration file. Refer to <a href="#">APPENDIX A, Installing the Instrument Configuration File</a>.</li> </ol>
The Administrative account is locked.	The Admin password was forgotten and the attempts exceed the limit.	<ol style="list-style-type: none"> <li>1. Select <b>Forgot password</b>.</li> <li>2. <a href="#">Contact us</a>.</li> </ol>
Plots are cut off when printing a PDF.	Plots need to be rearranged.	Rearrange the plots until the print preview screen shows all plots correctly.

## Backup and Restore

---

**IMPORTANT** If you have the Electronic Record Management software option installed, ensure the following prior to attempting to restore data:

- The target system includes all of the disk volumes that each experiment directory is saved to.
- The user performing the restore has *Set Experiment Directory* permission in CytExpert.

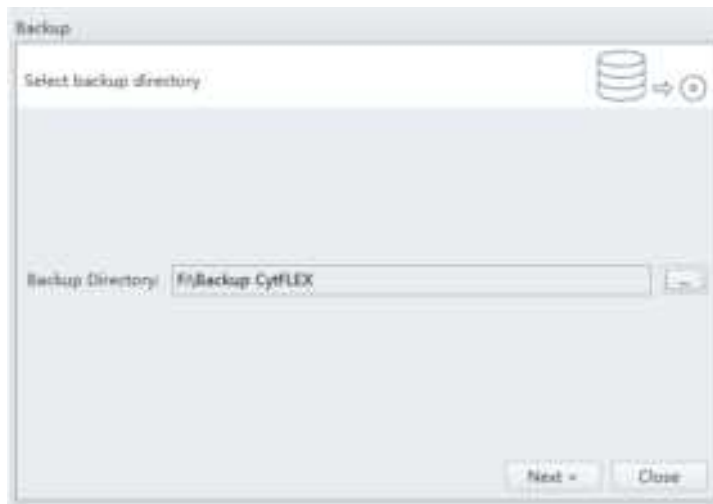
**NOTE** These procedures are only available if you have either the User Management or Electronic Record Management software option installed.

- **Electronic Record Management:** Both the database and experiment files can be backed up or restored.
- **User Management:** Only the database can be backed up or restored.

## Backup


---

- 1 Launch CytExpert.
- 2 Select **Backup/Restore > Backup**. The Backup window appears.

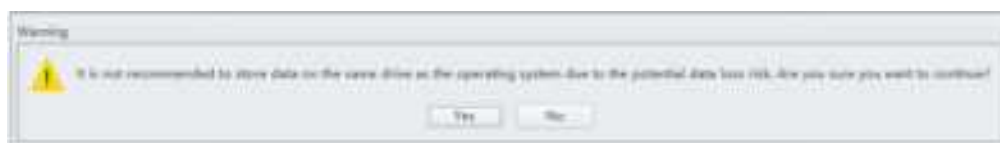


### CAUTION

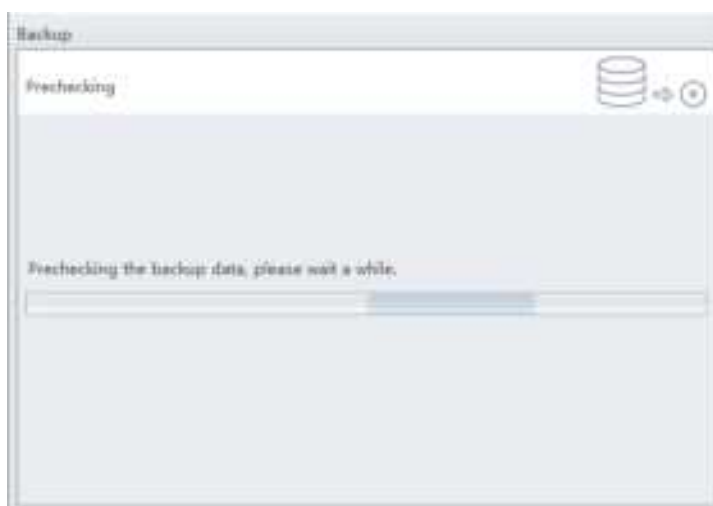
**Risk of data loss. Beckman Coulter recommends storing data on a drive other than the operating system.**

- 3 Select  and browse to the desired backup directory to store the backup data.

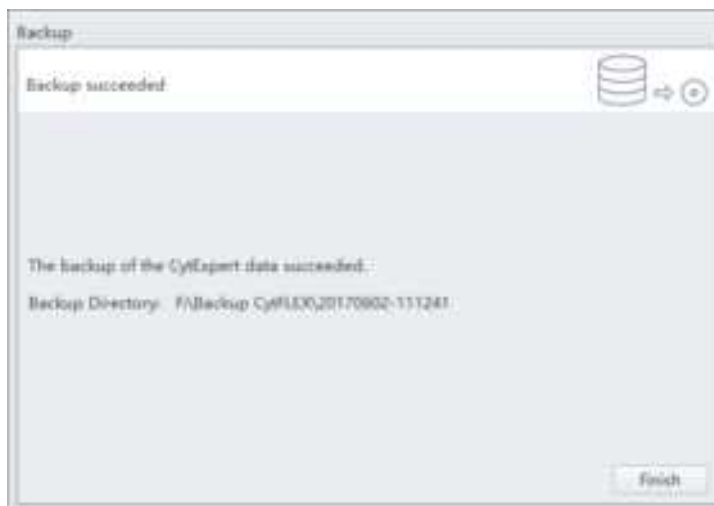
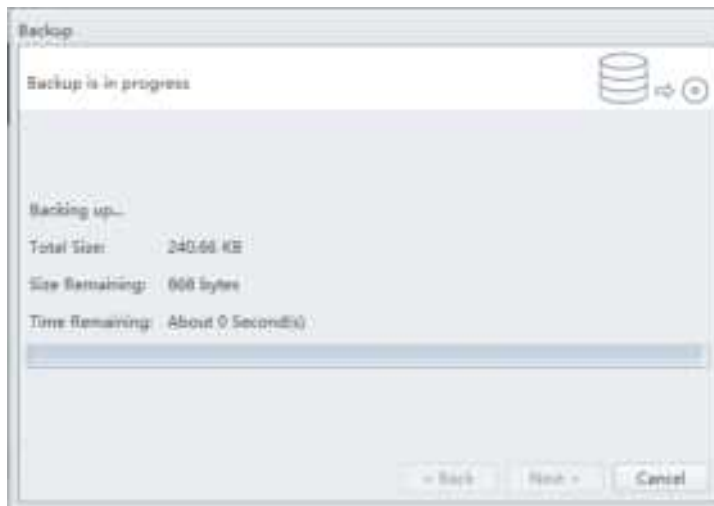
Selecting the same drive as the operation system prompts the following system warning:



**4** Select **Next**. The Prechecking window appears.



The backup starts automatically after the prechecking.



---

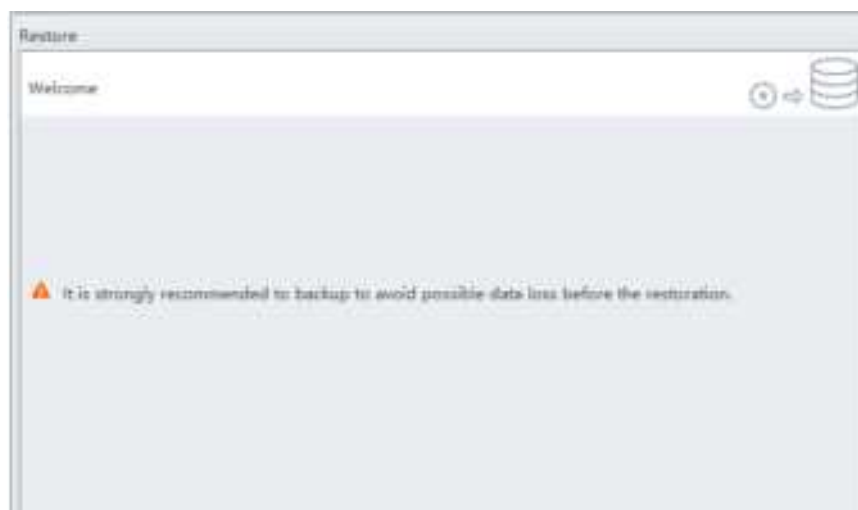
**5** Select **Finish**.

---

## Restore

---


- 1 Select **Backup/Restore > Restore**. The Restore window appears.

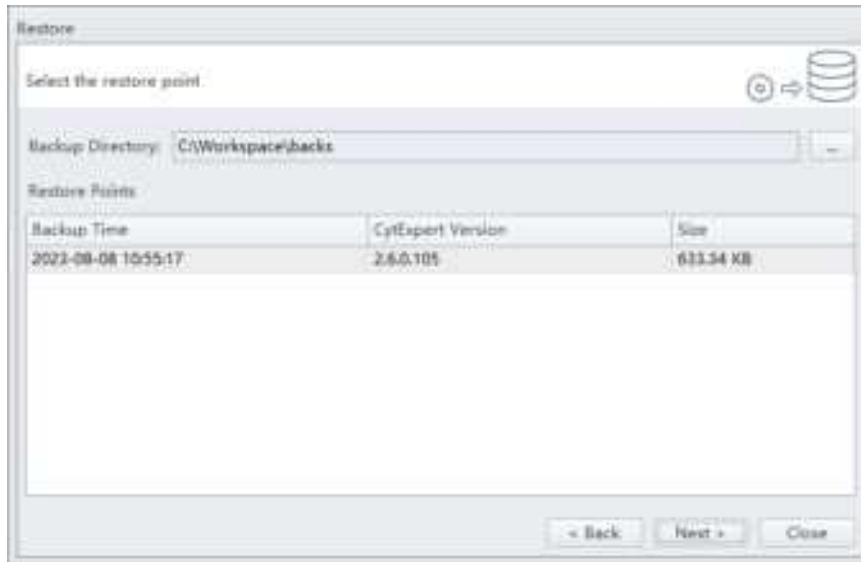



**NOTE** Ensure the data is backed up before the restoration.

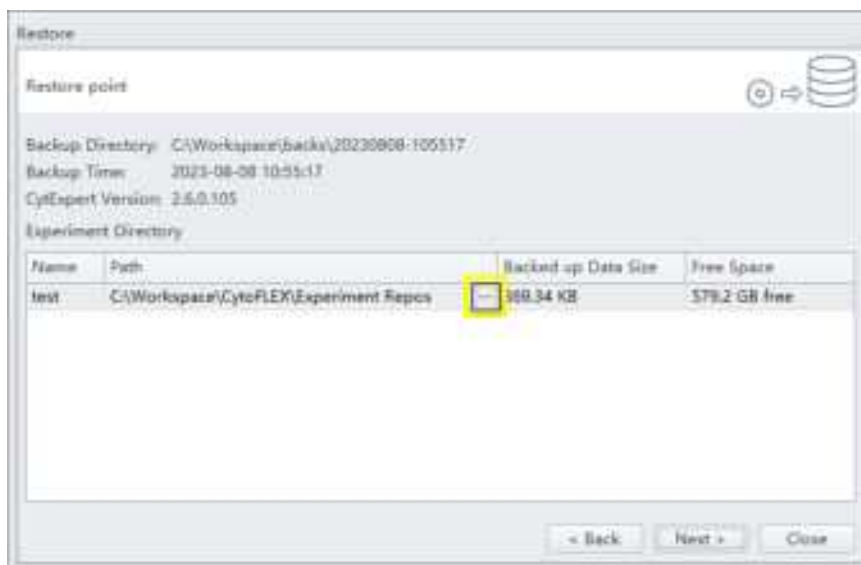
---

- 2 Select **Next**.

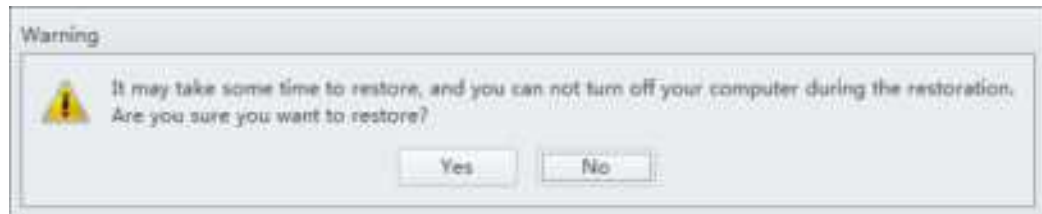
3 Select  and browse to the desired directory to restore.



**NOTE** When the CytExpert Electronic Record Management software option is installed, the experiment path can be modified. Select  and browse to the desired directory to modify the experiment path.

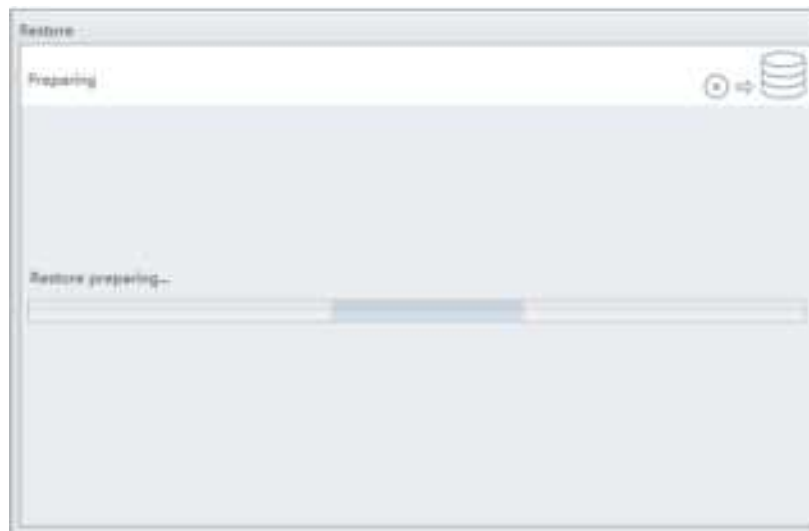


- 4 Select **Next**. The Warning window appears.

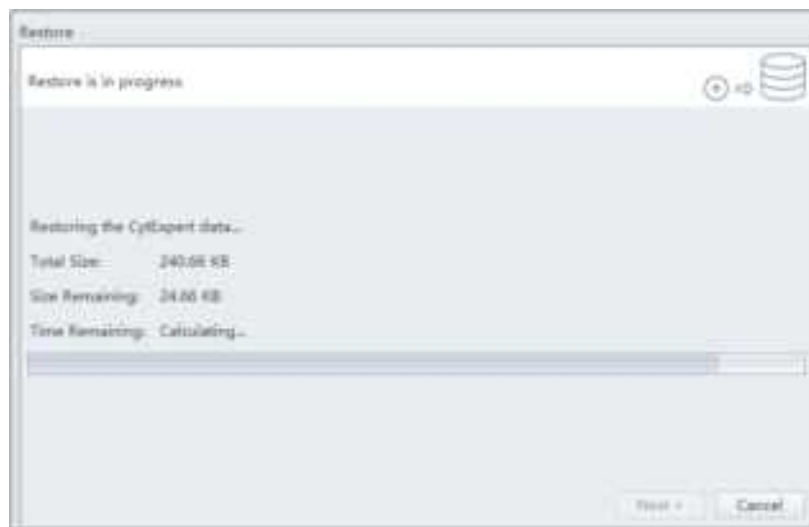


**IMPORTANT** Do not turn off your computer during the restoration.

- 5 Select **Yes**. The Preparing window appears.



The restoration starts automatically after finishing the preparation.





- 
- 6 Select **Finish**. The following system prompt appears.



- 
- 7 Select **OK**.

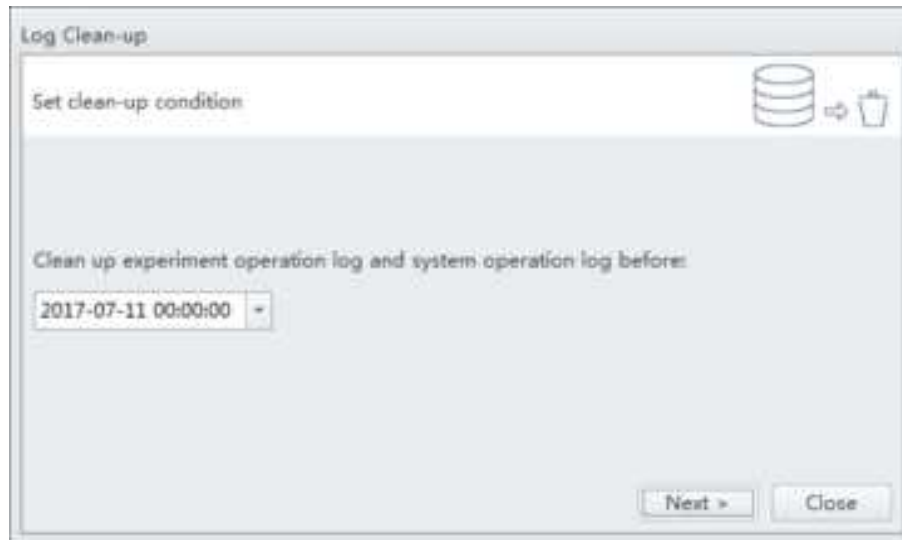
## Log Cleanup

Use Log Cleanup to delete Experiment Operation Logs and System Operation Logs before a selected date.

**NOTE** These procedures are only available if you have the Electronic Record Management software option installed.

- 
- 1 Ensure all experiment files are closed.

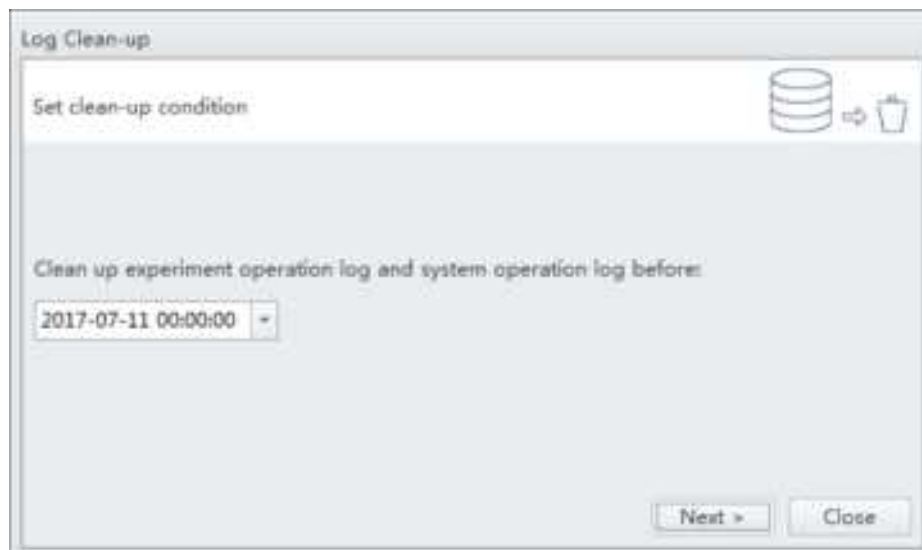
- 2 Select **Backup/Restore > Log Cleanup**. The Log Clean-up window appears.



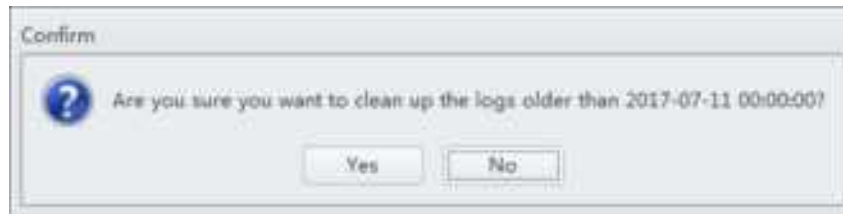
Close the experiment and try again if the operation system prompts the following message:



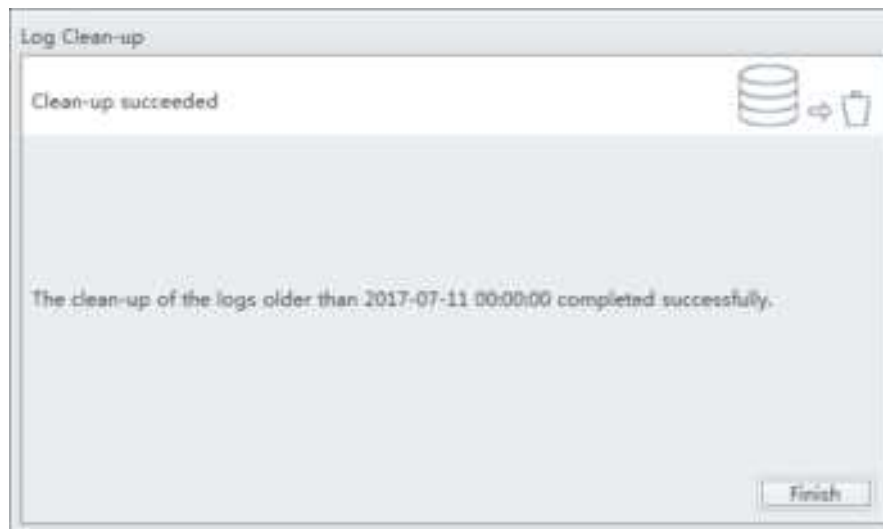
- 3 Select the desired date and time.



- 
- 4 Select **Next**. The Confirm window appears.



- 
- 5 Select **Yes**. The Clean-up succeeded window appears.



- 
- 6 Select **Finish**.
-

## Overview

---

This chapter describes how to carry out certain routine and nonscheduled cleaning procedures. Proper cleaning can help extend the service life of the instrument and ensure experimental accuracy. When conducting any cleaning, take all necessary biosafety precautions and use proper personal protective equipment.

This chapter contains information on:

- Routine Cleaning
  - Daily Clean
  - Daily Clean [With Plate Loader]
  - Cleaning the Sample Station
  - Deep Clean Procedure
  - Cleaning the 4 L Sheath Fluid Container
  - Cleaning the 4 L Waste Container
- Nonscheduled Cleaning
  - Surface Cleaning and Disinfection
  - Preparing the Instrument for Transport or Storage

## Routine Cleaning

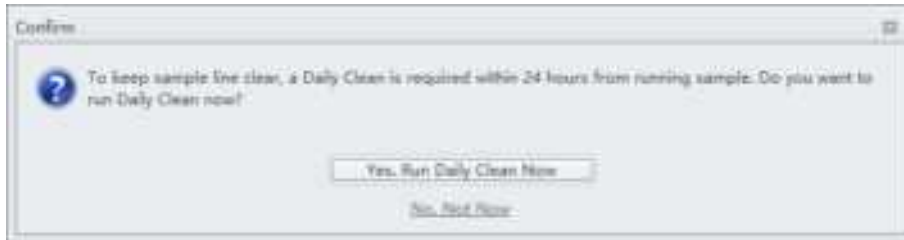
---

### Daily Clean

Daily Clean should be performed during instrument startup and instrument shutdown to clean the sample line.

After sampling an excessively large sample or a sample that can easily clog the sample probe, it is recommended to perform the Daily Clean procedure. Daily Clean can also be used to remove residual sample from previous tubes.

Perform a Daily Clean when the system reminder prompts you to do so. Otherwise, the reminder will prompt you repeatedly.



**NOTE** If you select **No. Not Now**, a warning message appears. Select **Yes** to skip Daily Clean or select **No** and perform Daily Clean. Refer to [CHAPTER 9, Running Daily Clean](#).



- 1 Open the CytExpert software and confirm that the instrument is connected and that it has already been initialized. Refer to [CHAPTER 4, Logging into the Software](#).
- 2 Select **Daily Clean** in the Cytometer menu.



- 3 Add 2 mL of FlowClean solution to an unused sample tube.

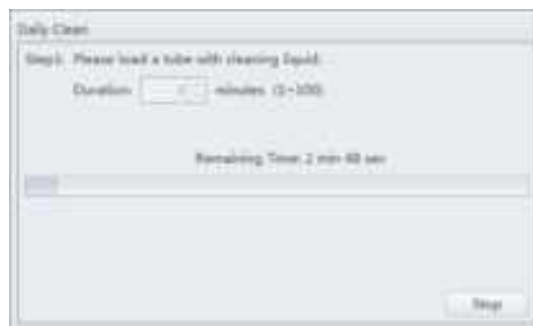
---

**4** Add 3 mL of DI water to an unused sample tube.

---

**5** Insert the sample tube with 2 mL of FlowClean solution into the sample holder and select **Run**.

**NOTE** The default cleaning time is 3 minutes.




---

**6** Remove the Flow Clean tube.

- 7 Insert the sample tube with 3 mL of DI water into the sample holder and select **Run** to perform the second step of the cleaning process.

**NOTE** The default cleaning time is 5 minutes.



- 8 After the process has been completed, remove the sample tube and close the Daily Clean window.

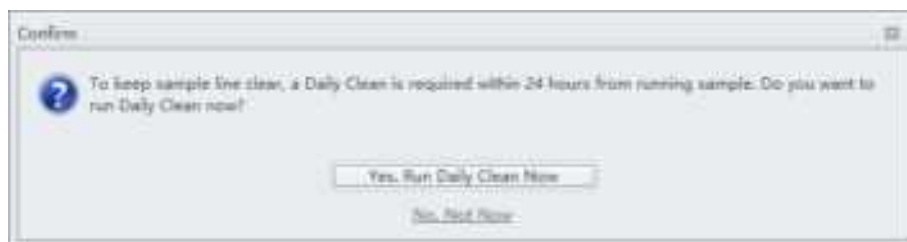


## Daily Clean [With Plate Loader]

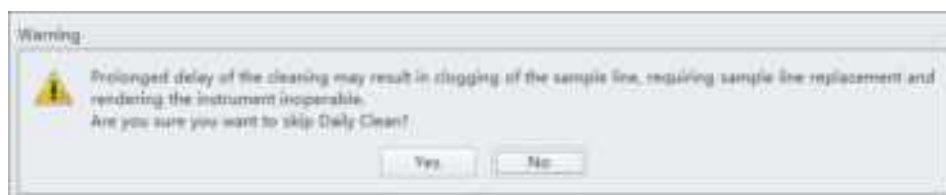
Daily Clean should be performed during instrument startup and instrument shutdown to clean the sample line.

After sampling an excessively large sample or a sample that can easily clog the sample probe, it is recommended to perform the Daily Clean procedure. Daily Clean can also be used to remove residual sample from previous tubes.

Perform a Daily Clean when the system reminder prompts you to do so. Otherwise, the reminder will prompt you repeatedly.

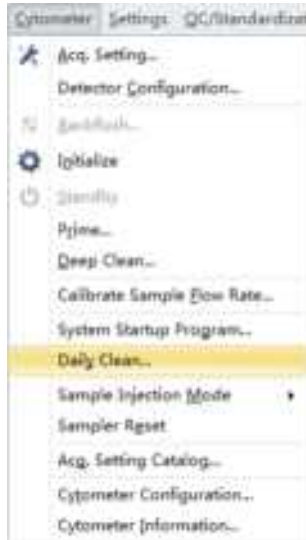


**NOTE** If you select **No. Not Now**, a warning message appears. Select **Yes** to skip Daily Clean or select **No** and perform Daily Clean. Refer to [CHAPTER 9, Running Daily Clean](#).



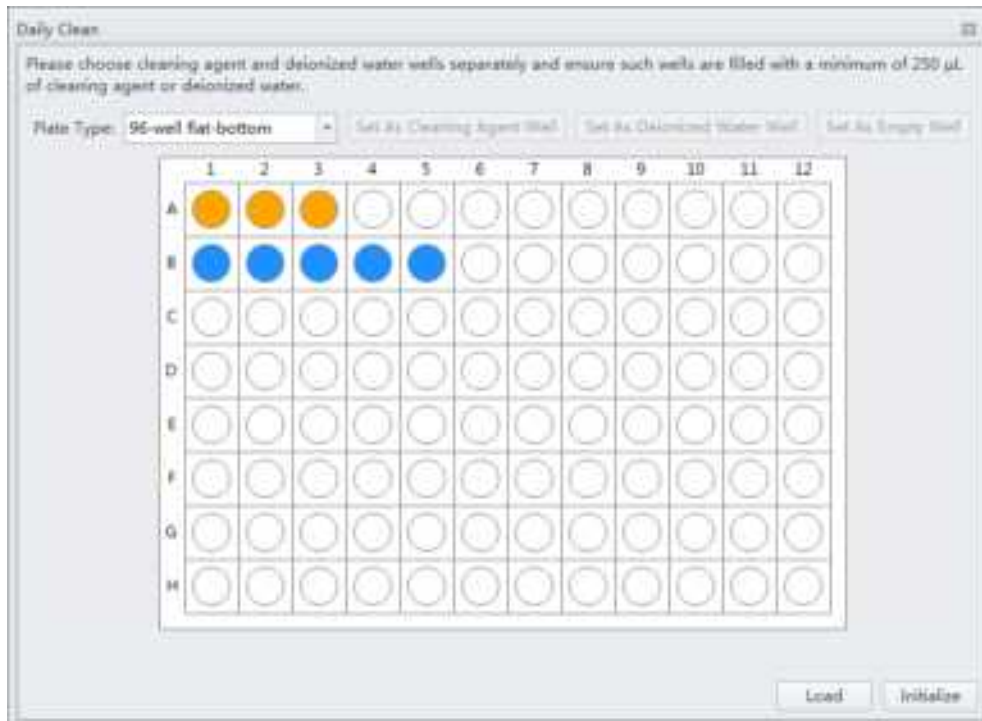
- 1 Open the CytExpert software and confirm that the instrument is connected and that it has already been initialized. Refer to [CHAPTER 4, Logging into the Software](#).

- 2 Select **Daily Clean** in the Cytometer menu. The Daily Clean window appears. The plate loader automatically ejects the plate holder stage.



- 3 Follow the on screen software prompts and select the desired wells for cleaning agent and deionized water.

[CytoFLEX LX Shown]



**IMPORTANT** You must select at least one cleaning solution well and one water well.

- a. Select the desired wells for the cleaning agent and select **Set As Cleaning Agent Well**.
- b. Select the desired wells for the deionized water and select **Set As Deionized Water Well**.

**NOTE** To deselect water wells, select the desired well and select **Set As Empty Well**.

- c. Select the *Turn off cytometer after daily clean* checkbox to automatically shutdown the cytometer after Daily Clean is finished. [**CytoFLEX LX Only**]

---

**4** Select **Start** to start the cleaning procedure. The message *Please confirm that the correct plate is placed properly and press OK* appears. Select **OK**.

---

**5** Select **Close**.

---

## Cleaning the Sample Station



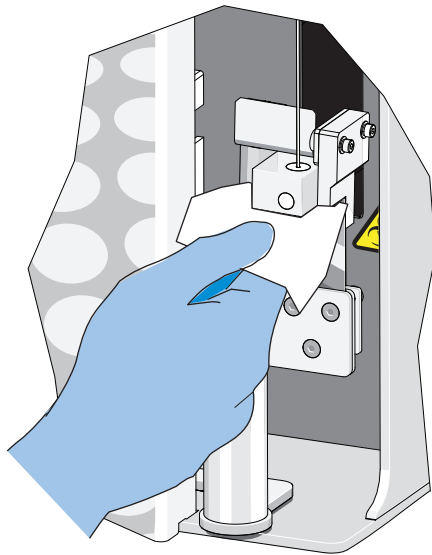
Carry out semi-automatic cleaning for the sample injection device once a week.

- 
- 1** Ensure that the system has been shut down properly. Refer to [CHAPTER 9, Shutting Down the Instrument](#).

 **WARNING**

**Risk of chemical injury from bleach. To avoid contact with the bleach, use barrier protection, including protective eyewear, gloves, and suitable laboratory attire. Refer to the Safety Data Sheet for details about chemical exposure before using the chemical.**

- 2 Use a piece of absorbent material with a 10% bleach solution (1 part high-quality, fragrance-free, gel-free bleach [5 to 6% solution of sodium hypochlorite - available chlorine] with 9 parts DI water) to wipe off all surfaces in the sample station, while taking all necessary biological safety precautions.



- 3 Wipe off the bottom of the semi-automatic sample injection device.

### Cleaning the Sample Probe



When problems such as blockage of the sample probe occur, it is required to replace or clean the sample probe.

- 1 Confirm that the instrument is in the standby state or that the power supply is turned off.

**WARNING**

Risk of biohazardous contamination if you have skin contact with the sample probe or the sample peristaltic pump tubing. The sample probe and the sample peristaltic pump tubing might contain residual biological material and must be handled with care. Clean up spills immediately. Dispose of the sample probe and the sample peristaltic pump tubing in accordance with your local regulations and acceptable laboratory procedures.

- 2 Remove the sample probe. Refer to [CHAPTER 12, Replacing the Sample Probe and/or the Sample Peristaltic Pump Tubing](#).
- 3 Put the sample probe into a clean container and soak it in clean water. Use an ultrasonic cleaning device to clean for 2 minutes.
- 4 Reattach the sample probe to the sample peristaltic pump tubing and confirm that the bead on the sample probe touches the sleeve on the end of the sample peristaltic pump tubing.

**IMPORTANT** To ensure that the proper placement of the sample probe, push the sample pump cover up while installing the thumbscrew.

- 5 Install the sample pump cover.
- 6 If ineffective, replace with a new sample probe. Refer to [CHAPTER 12, Replacing the Sample Probe and/or the Sample Peristaltic Pump Tubing](#).

## Deep Clean Procedure

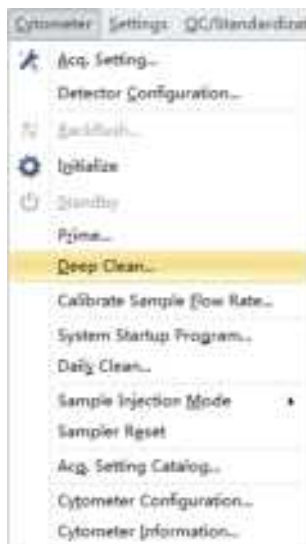
Carry out a deep clean once a month to clean the instrument flow cell. If the unit will be shutdown and not used for more than 10 days, it is recommended to complete one deep clean before resuming use.

- 1 Place the instrument in standby state.
- 2 Remove the right-side cover. Refer to [CHAPTER 12, Right-Side Cover Removal and Reinstallation](#).

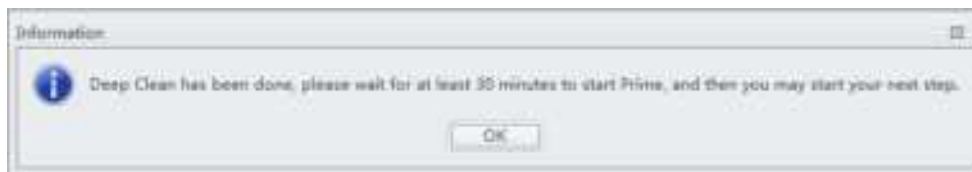
- 
- 3 Confirm that the Deep Clean solution volume in the bottle located inside the Fluidics module is sufficient.

To prepare and add more Deep Clean solution, refer to [CHAPTER 12, Adding the Deep Clean Solution](#).

- 
- 4 Select **Deep Clean** in the Cytometer menu. The software message *Are you sure to start deep clean?* appears. Select **Yes** to start the Deep Clean process in the instrument flow cell.



- 
- 5 The status bar prompts that a deep clean is under way. Wait for the Deep Clean process to finish. The following software message appears:



Select **OK**.

- 
- 6 Allow the cleaning solution to remain in the flow cell for approximately 30 minutes. If you are required to postpone the cleaning time, do not exceed 24 hours. During the Deep Clean cycle, the power supply of the unit can be turned off, but the instrument cannot be initialized.

- 
- 7 Select **Prime** in the Cytometer menu. The software message *Are you sure to start Prime?* appears. Select Yes.



- 
- 8 Run Daily Clean. Refer to [Daily Clean](#).
- 
- 9 Perform initialization as required (see [CHAPTER 4, Initializing the Instrument](#)) to carry out the next experiment or to turn off the instrument.
- 
- 10 Reinstall the right-side cover. Refer to [CHAPTER 12, Right-Side Cover Removal and Reinstallation](#).
- 

## Cleaning the 4 L Sheath Fluid Container

Clean the sheath fluid container once a month.

- 
- 1 Confirm that the instrument is turned off or is in the standby state.
- 
- 2 Remove the sheath fluid container from the Fluid Container holder.
- 
- 3 Remove the sheath fluid harness from the sheath fluid container.
-

- 
- 4 Empty the residual sheath fluid from the sheath fluid container.

---

  - 5 Add about 50 to 100 mL of CytoFLEX Sheath Fluid to the sheath fluid container.

---

  - 6 Insert the sheath fluid harness back into the sheath fluid container and tightly close the sheath fluid container cap.

---

  - 7 Swirl the sheath fluid in the sheath fluid container, rinsing all surfaces.

---

  - 8 Empty the sheath fluid container.

---

  - 9 Refill the sheath fluid container. Refer to [CHAPTER 12, Filling the 4 L Sheath Fluid Container](#).
- 

## Cleaning the 4 L Waste Container



Clean the waste container once a month.

- 
- 1 Confirm that the instrument is turned off or is in the standby state.

---

  - 2 Remove the waste container from the Fluid Container holder.
- 

 **WARNING**

**Risk of biohazardous contamination if you have skin contact with the waste container, its contents, and its associated tubing. The waste container and its associated tubing could contain residual biological material and must be handled with care. Clean up spills immediately.**

- 3 Remove the harness from the waste container.

**⚠ WARNING**

Risk of biohazardous contamination if you have skin contact with the waste container, its contents, and its associated tubing. The waste container and its associated tubing could contain residual biological material and must be handled with care. Clean up spills immediately. Dispose of the contents of the waste container in accordance with your local regulations and acceptable laboratory procedures.

- 4 Empty the waste container.

**⚠ WARNING**

Risk of chemical injury from bleach. To avoid contact with the bleach, use barrier protection, including protective eyewear, gloves, and suitable laboratory attire. Refer to the Safety Data Sheet for details about chemical exposure before using the chemical.

- 5 Add 1 L of sodium hypochlorite solution with 0.5% active chlorine to the waste container.

- 6 Insert the waste harness back into the waste container and tightly close the waste container cap.

**⚠ CAUTION**

Risk of damage to the sheath fluid harness and/or waste harness. Do not leave the sodium hypochlorite solution in the fluid containers longer than 10 minutes.

- 7 Let stand for 5 to 10 minutes.

**⚠ WARNING**

Risk of chemical injury from bleach. To avoid contact with the bleach, use barrier protection, including protective eyewear, gloves, and suitable laboratory attire. Refer to the Safety Data Sheet for details about chemical exposure before using the chemical.

- 8 Dispose of the sodium hypochlorite solution in accordance with your local regulations and acceptable laboratory procedures.

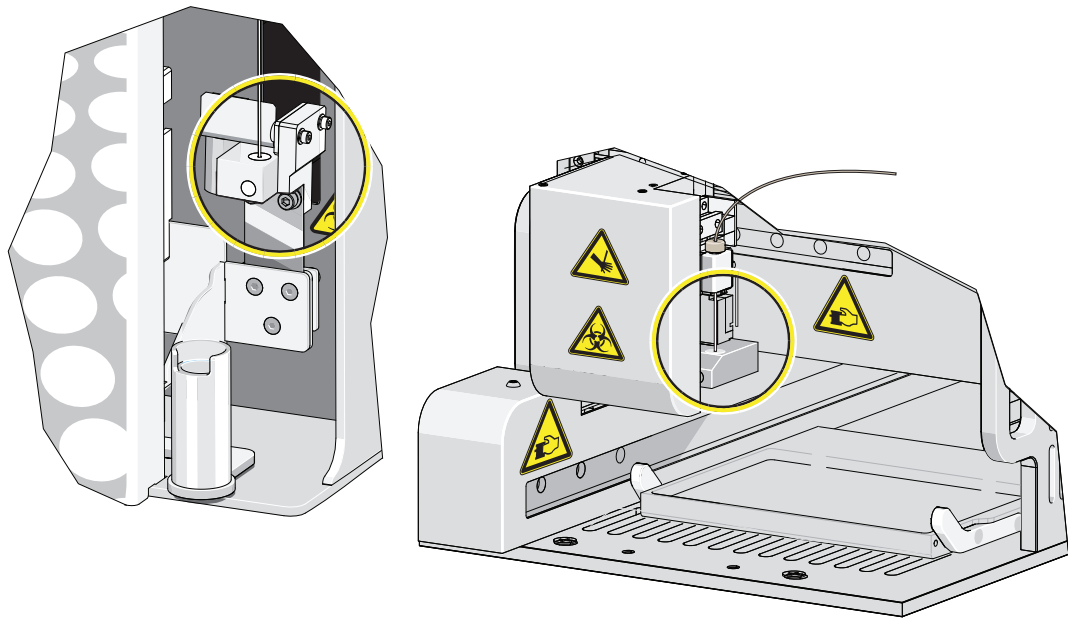
- 9 Use deionized water to rinse the waste container and the waste harness. Ensure that there is no sodium hypochlorite residue.

- 10 Place the waste container back into the Fluid Container holder.

## Nonscheduled Cleaning

### Surface Cleaning and Disinfection

- 1 Wipe all external surfaces of the instrument clean with water and wipe dry immediately.
- 2 If you have a plate loader installed on your instrument, remove the front cover. Refer to [CHAPTER 12, Front Cover Removal and Reinstallation](#).
- 3 Wipe the wash collar modules in the single tube station and the plate loader station with 100% isopropanol and wipe dry immediately.



- 4 If you have a plate loader installed on your instrument, reinstall the front cover. Refer to [CHAPTER 12, Front Cover Removal and Reinstallation](#).

 **WARNING**

**Risk of chemical injury from bleach. To avoid contact with the bleach, use barrier protection, including protective eyewear, gloves, and suitable laboratory attire. Refer to the Safety Data sheet for details about chemical exposure before using the chemical.**

- 5 Prepare a cleaning solution of 1 part high-quality, fragrance-free, gel-free bleach (5 to 6% solution of sodium hypochlorite - available chlorine) and 9 parts distilled water.

 **CAUTION**

**Risk of instrument damage. The instrument label can peel or fade, and the wash collar can become brittle and crack over time if these surfaces are wiped clean using the bleach solution followed by the 70% ethanol. Do not clean the label or the wash collar with the bleach solution followed by the 70% ethanol. Only use the specified cleaning methods in Steps 1 and 3 to clean these surfaces.**

 **CAUTION**

**Risk of personal injury if electronic equipment is used near fumes or flammable gases. Ethanol is a flammability hazard. Avoid this risk by never using it in or near operating instruments.**

- 6 Wipe down all exposed surfaces with the bleach solution and then 70% ethanol. Pay special attention to the Sampling area.  
Be sure to avoid wiping the instrument label and wash collar module with the bleach solution and 70% ethanol.

## Preparing the Instrument for Transport or Storage



When the instrument is to be transported or is not to be used for 30 days or more, complete the emptying processes to prevent instrument damage and to reduce the possibility of biological contamination. [Contact us](#) if you have any questions.

- 1 Run the Deep Clean procedure. Refer to [Deep Clean Procedure](#).
- 2 Run the Daily Clean procedure. Refer to [Daily Clean](#).

- 
- 3 Clean the Sample Station. Refer to [Cleaning the Sample Station](#).

---

  - 4 Empty the sheath fluid container and the waste container (see [CHAPTER 12, Emptying the 4 L Waste Container](#)).

---

  - 5 Clean and disinfect all surfaces. Refer to [Surface Cleaning and Disinfection](#).

 **WARNING**

**Risk of biohazardous contamination if you have skin contact with the waste container, its contents, and its associated tubing. The waste container and its associated tubing could contain residual biological material and must be handled with care. Clean up spills immediately. Dispose of the contents of the waste container in accordance with your local regulations and acceptable laboratory procedures.**

- 6 Clean the sheath fluid container and the waste container. Refer to [Cleaning the 4 L Sheath Fluid Container](#).

---

- 7 Remove the right-side cover (see [CHAPTER 12, Right-Side Cover Removal and Reinstallation](#)).

---

- 8 Remove the Deep Clean solution bottle from the bracket, empty the Deep Clean solution bottle, and rinse with DI water. Then, attach the Deep Clean solution bottle to the bracket.

---

- 9 Remove the Plate Loader module if applicable (see [CHAPTER 12, Plate Loader Module Removal and Reinstallation \[With Plate Loader\]](#)).

---

- 10 Power down and disconnect all the cables and sheath fluid and waste harnesses.

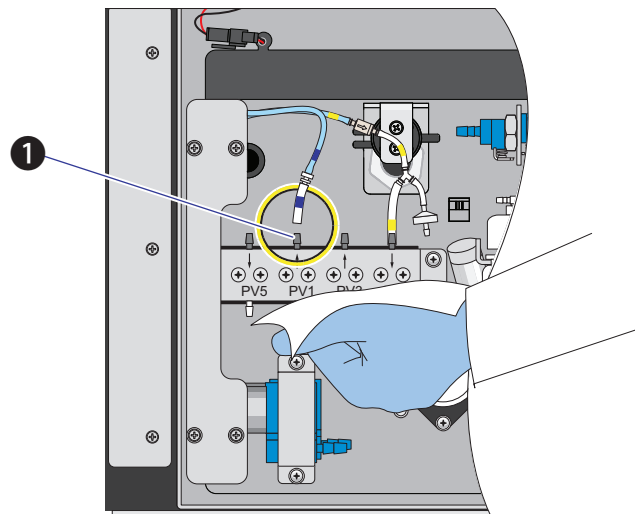
**CAUTION**

Risk of instrument damage. The Cytometer can suffer irreparable damage if it is exposed to subfreezing temperatures while it still contains liquid. Always drain the flow cell after cleaning the Cytometer if the Cytometer will be stored or transported in subfreezing temperatures.

**WARNING**

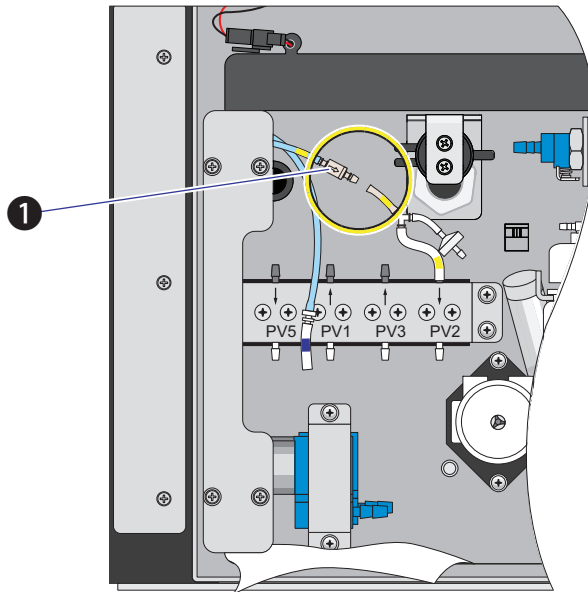
Risk of contamination from biohazardous material. Always wear PPE when performing this procedure as you can contact components with blood residue when handling the Fluidics module. Dispose of any absorbent materials used to collect or clean up leaks in accordance with the local regulations and acceptable laboratory procedures.

- 11 Disconnect the blue-labeled tubing from the pneumatic valve PV1 and hold the absorbent material under the disconnected tubing to collect any dripping liquid.



1. PV1

- 
- 12** Disconnect the yellow-labeled tubing connected to the choke to vent the flow cell, allowing it to drain.



1. Choke

- 
- 13** Verify that liquid has stopped dripping from the blue-labeled tubing.

**NOTE** The flow cell is empty when liquid stops dripping from the blue-labeled tubing.

- 
- 14** Dispose of the absorbent material used to collect the liquid in accordance with the local regulations and acceptable laboratory procedures and cleanup any spills.

- 
- 15** Reconnect the blue-labeled tubing to PV1.

- 
- 16** Reconnect the yellow-labeled tubing to the choke.

- 
- 17** Reinstall the right-side cover (see [CHAPTER 12, Right-Side Cover Removal and Reinstallation](#)).

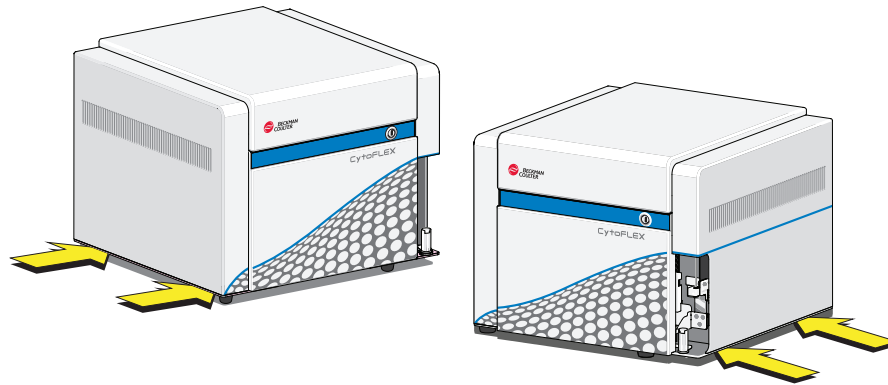
- 
- 18** Ensure that the optical filters are seated properly.

- 
- 19** Ensure that the top cover is tightly closed.

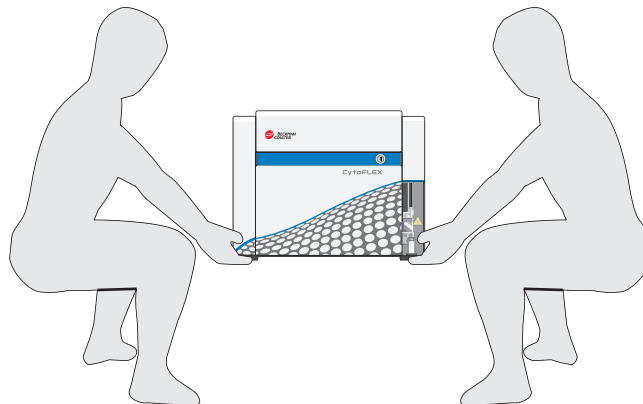
- 20** If the instrument is to be transported or stored, put the instrument and the Plate Loader module (if applicable) into the Beckman Coulter supplied packing and comply with the requirements in [APPENDIX A, Instrument Transportation and Storage](#), regarding correct placement during transportation and storage.

### Lifting and Carrying Instructions

- 1** Position a person on the left and right sides of the Cytometer.
- 2** Reach under the base of the Cytometer in the areas indicated by the arrows in the figure below.



- 3** Gently lift the Cytometer as shown in the figure below.



---

 **WARNING**

**Risk of personal injury. Use caution when lowering the Cytometer to avoid pinching fingers.**

- 4** Lower the Cytometer to its designated location.
-

# Replacement/Adjustment Procedures

## Overview

---

This chapter describes how to carry out certain routine and nonscheduled maintenance procedures. Proper maintenance can help extend the service life of the instrument and ensure experimental accuracy. When conducting any maintenance work, take all necessary biosafety precautions.

**IMPORTANT** In addition to parts specifically discussed, for all replacement parts, use only parts provided by Beckman Coulter to ensure proper functioning of the instrument. Never disassemble any part of the instrument without prior authorization. Beckman Coulter assumes no responsibility for any instrument problems resulting from the use of any part not authorized by Beckman Coulter for use with the instrument.

This chapter contains information on:

- Routine Replacement/Adjustment
  - Front Cover Removal and Reinstallation
  - Right-Side Cover Removal and Reinstallation
  - Filling the 4 L Sheath Fluid Container
  - Replacing the 10 L Sheath Fluid Cubitainer
  - Emptying the 4 L Waste Container
  - Emptying the 10 L Waste Cubitainer
  - Managing the Maintenance Reminder
  - Adding the Deep Clean Solution
  - Replacing the Sheath Fluid Filter
  - Unclogging the Sample Probe [With Sample Injection Mode Control Kit]
  - Unclogging the Sample Probe [Without Sample Injection Mode Control Kit]
  - Replacing the Sample Probe and/or the Sample Peristaltic Pump Tubing
  - Replacing the Sample Probe Assembly [With Plate Loader]
  - Changing the Sample Probe from the Single Tube Sample Station to the Plate Loader [CytoFLEX With Plate Loader]
  - Changing the Sample Probe from the Plate Loader to the Single Tube Sample Station [CytoFLEX With Plate Loader]
  - Inspecting the Liquid Flow Path for Leaks
  - Priming the Flow Cell
  - Replacing the Plate Holder [With Plate Loader]
  - Plate Loader Module Removal and Reinstallation [With Plate Loader]
  - Changing the Event Rate Setting

- Nonscheduled Replacement/Adjustment
  - Calibrating the Sample Flow Rate
  - Calibrating the Sample Flow Rate [With Plate Loader]
  - Setting Laser Delay
  - Replacing the Optical Filter
  - Replacing the Fuse
  - Replacing the Sheath Fluid Harness and/or Waste Harness
  - Changing Sample Mixing and Backflush Settings
  - Calibrating the Plate Position [With Plate Loader]

## Routine Replacement/Adjustment

---

### Front Cover Removal and Reinstallation

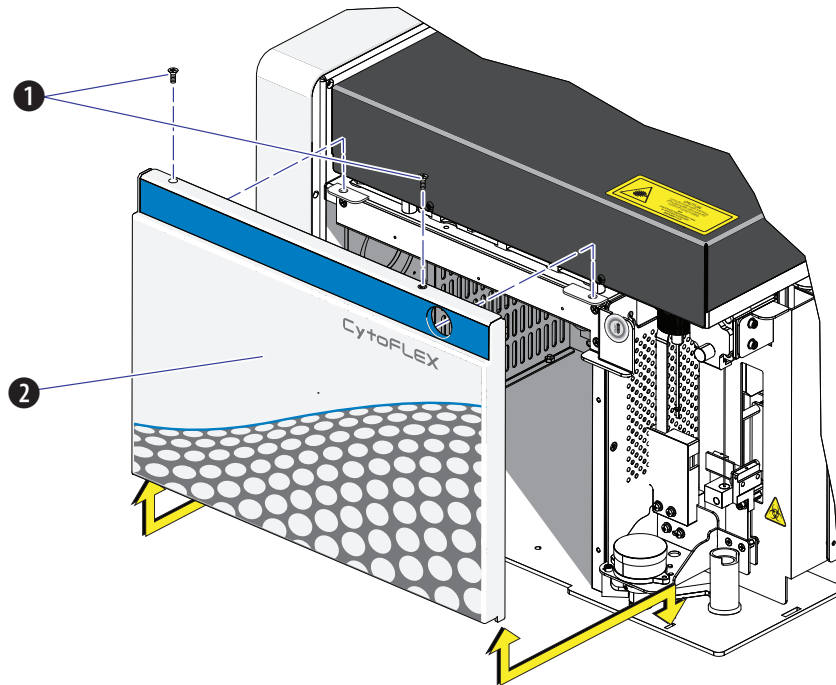
#### Removal



**Risk of personal injury from electric shock caused by contacting exposed electronic components. Power down the instrument before removing the front cover of the Cytometer.**

- 1 Exit the system software.
- 2 Turn off the main power switch on the back of the Cytometer.
- 3 Open the top cover.

- 
- 4** Remove the two screws securing the front cover and pull the front cover forward.



- 1. Securing screws
- 2. Front cover

- 
- 5** Lift the front cover up and out of the slots in the frame.

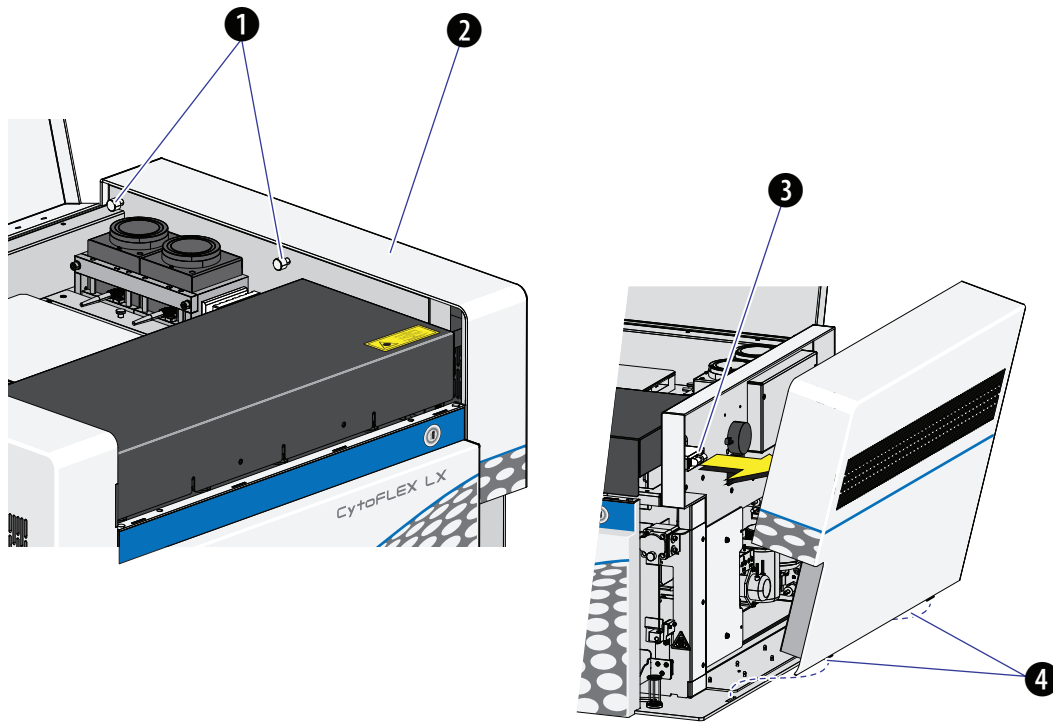
---

### Reinstallation

- 1** Slide the tabs on the bottom of the front cover into the slots in the bottom of the frame.
  - 2** Push in the latches on the front cover to retract the pins, push the front cover into place, and release the latches to secure the cover.
  - 3** Close the top cover.
-

## Right-Side Cover Removal and Reinstallation

**IMPORTANT** The CytoFLEX LX flow cytometer only requires you to unfasten the thumbscrews the first time. There is a retaining clip that is used to secure the right-side cover without the need for the thumbscrews, if desired. Once the thumbscrews are unfastened, the right-side cover can simply be pulled off of the retaining clip for removal and pushed onto the retaining clip for reinstallation. Ensure the top cover is open before removing the right-side cover from the retaining clip.

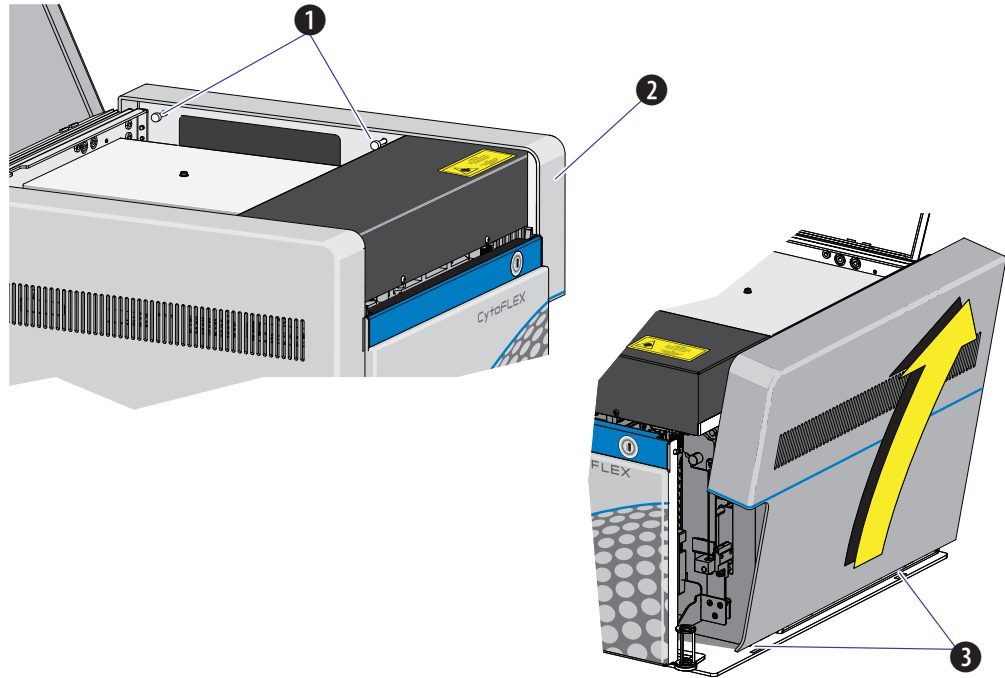


1. Thumbscrews
2. Right-side cover
3. Retaining clip
4. Tabs

### Removal

- 1 Open the top cover.

- 2 Unfasten the two captive thumbscrews for the right-side cover.



1. Captive thumbscrews
2. Right-side cover
3. Tabs

- 3 Lift the right-side cover up and out of the slots in the frame.

### Reinstallation

- 1 Slide the tabs on the bottom of the right-side cover into the slots in the bottom of the frame and push the cover into place.
- 2 Fasten the two captive thumbscrews to secure the right-side cover.
- 3 Close the top cover.

## Filling the 4 L Sheath Fluid Container

- 1 Confirm that the instrument is turned off or is in the standby state.
- 2 If necessary, remove any cardboard cutouts from the new CytoFLEX Sheath Fluid cubitainer. If you do not need a new cubitainer, skip to Step 7.
- 3 Locate the spigot inside the cardboard cutout.
- 4 Remove the cap and seal from the new sheath cubitainer. Be sure to completely remove the foil seal.
- 5 Screw on the spigot.
- 6 Unscrew the sheath fluid harness from the sheath fluid container and place in the fluid sensor holder cutout (refer to [Figure 1.7.](#)) to prevent contamination of the sheath fluid harness.

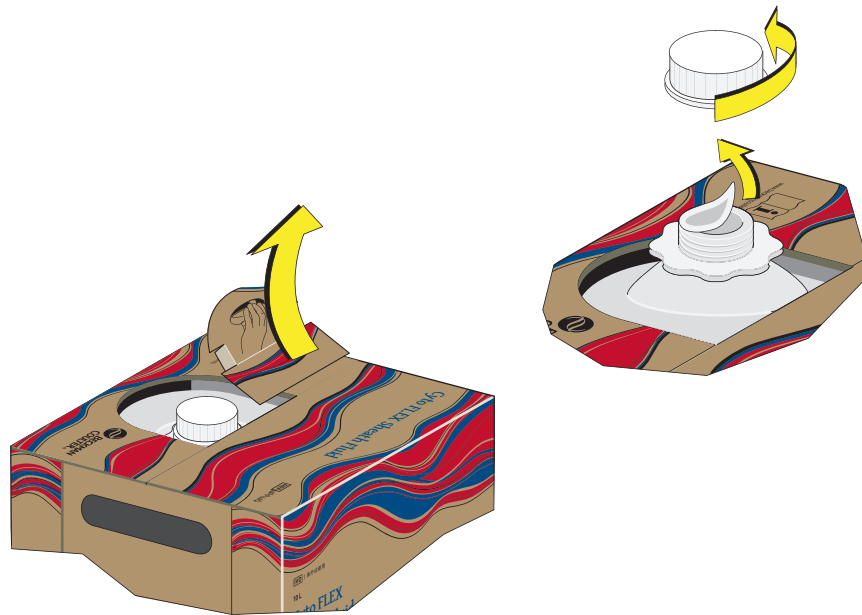
 **CAUTION**

**Risk of instrument damage. Remove the sheath fluid container from the Fluid Container holder and fill away from the instrument to prevent spills that could damage the instrument circuitry.**

- 7 Remove the sheath fluid container from the Fluid Container holder.
- 8 Hold the Sheath fluid container under the CytoFLEX Sheath Fluid cubitainer ensuring the cubitainer is resting on a stable surface.
- 9 Fill the sheath fluid container.
- 10 Reinstall the sheath fluid harness onto the sheath fluid container.
- 11 Place the sheath fluid container back into the Fluid Container holder.

## Replacing the 10 L Sheath Fluid Cubitainer

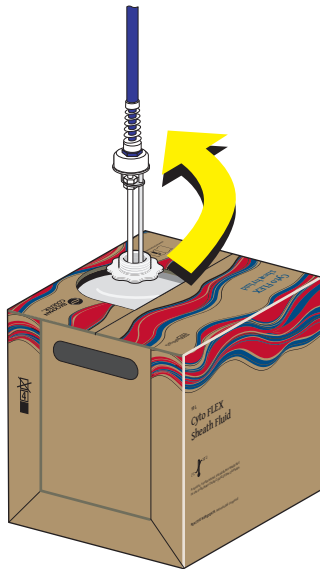
- 1 Confirm that the instrument is turned off or is in the standby state.
- 
- 2 If necessary, remove any cardboard cutouts from the new CytoFLEX Sheath Fluid cubitainer. Remove the cap and seal from the new sheath fluid cubitainer. Be sure to completely remove the foil seal.



**CAUTION**

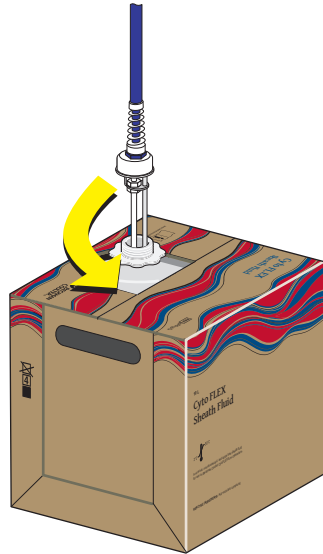
Misleading results could occur if you contaminate the sheath fluid. Be careful not to contaminate the sheath fluid. Do not let your fingers, paper towels, or other objects touch the pickup tube assembly.

- 3 Unscrew the plastic cap that secures the pickup tube assembly into the old sheath fluid container and lay it on a leakproof disposable container, such as a glove or beaker. Lift the pickup tube assembly straight up and out.

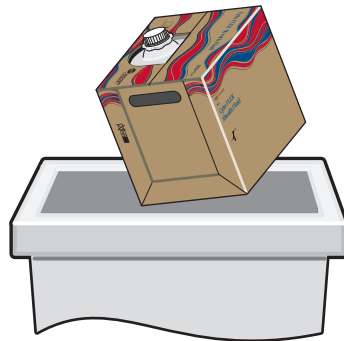


- 4 Inspect the pickup tube assembly and replace it if necessary.

- 
- 5 Carefully insert the pickup tube assembly straight into the new sheath fluid cubitainer.  
Tighten the cap.



- 
- 6 Place the 10 L sheath fluid cubitainer to the left of the instrument.
  - 7 Put the cap from the new container onto the old container and dispose of the container properly.



---

## Emptying the 4 L Waste Container



- 
- 1 Confirm that the instrument is turned off or is in the standby state.

- 
- 2 Remove the waste harness (see [Figure 1.7](#)). The waste harness from the Cytometer is connected to a 4 L waste container.
- 
- 3 Remove the waste container from the Fluid Container holder.

 **WARNING**

**Risk of biohazardous contamination if you have skin contact with the waste container, its contents, and its associated tubing. The waste container and its associated tubing might contain residual biological material and must be handled with care. Clean up spills immediately. Dispose of the contents of the waste container in accordance with your local regulations and acceptable laboratory procedures. Use proper personal protective equipment.**

- 4 Empty the waste container. Dispose of the waste in accordance with your local regulations and acceptable laboratory procedures.

 **WARNING**

**Risk of chemical injury from bleach. To avoid contact with the bleach, use barrier protection, including protective eyewear, gloves, and suitable laboratory attire. Refer to the Safety Data Sheet for details about chemical exposure before using the chemical.**

- 5 Add 400 mL of high-quality, fragrance-free, gel-free bleach (5 to 6% solution of sodium hypochlorite - available chlorine) to the waste container.
- 
- 6 Reinstall the waste harness in the waste container.
- 
- 7 Put the waste container in the Fluid Container holder.
- 

## Emptying the 10 L Waste Cubitainer



- 
- 1 Confirm that the instrument is turned off or is in the standby state.

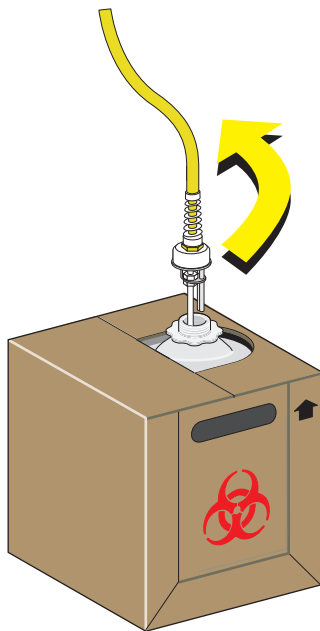
- 2 Lift the waste cubitainer and swirl it before removing the cap.



**WARNING**

Risk of biohazardous contamination if you have skin contact with the waste cubitainer, its contents, and its associated tubing. The waste cubitainer and its associated tubing might contain residual biological material and must be handled with care. Clean up spills immediately. Dispose of the contents of the waste cubitainer in accordance with your local regulations and acceptable laboratory procedures.

- 3 Unscrew the cap and lay it on a leakproof disposable container, such as a glove or beaker.



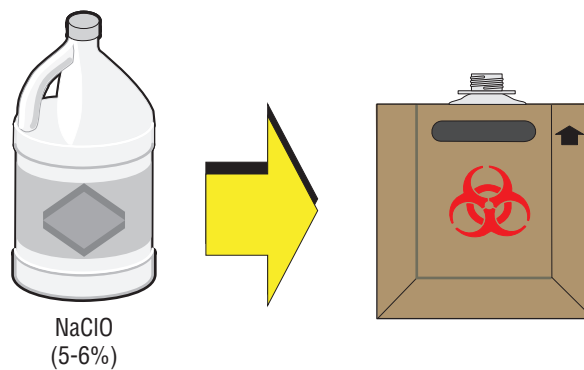
- 4 Empty the waste cubitainer according to your laboratory's procedures.

**NOTE** Take proper precautions to avoid spills if you are emptying the waste cubitainer into a sink, drain, or larger container. When moving the waste cubitainer to dispose of its contents, be sure the cap is secure to avoid spills.

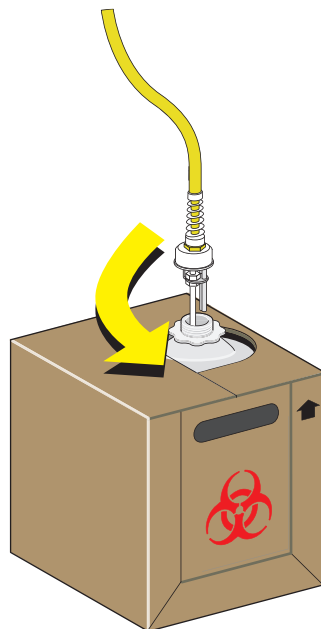
**⚠ WARNING**

**Risk of chemical injury from bleach. To avoid contact with the bleach, use barrier protection, including protective eyewear, gloves, and suitable laboratory attire. Refer to the Safety Data Sheet for details about chemical exposure before using the chemical.**

- Put about 1 L of high-quality, fragrance-free, gel-free bleach (5 to 6% solution of sodium hypochlorite - available chlorine) in the 10 L waste cubitainer to cover the bottom of the cubitainer.



- Replace the cap on the new waste cubitainer and securely tighten.





**NOTE** Properly dispose of the leakproof disposable container used in Step 3 after you screw the cap back on the waste container.

## Managing the Maintenance Reminder


The maintenance reminder tracks the last maintenance date and initiates a reminder to complete maintenance for the following three items:

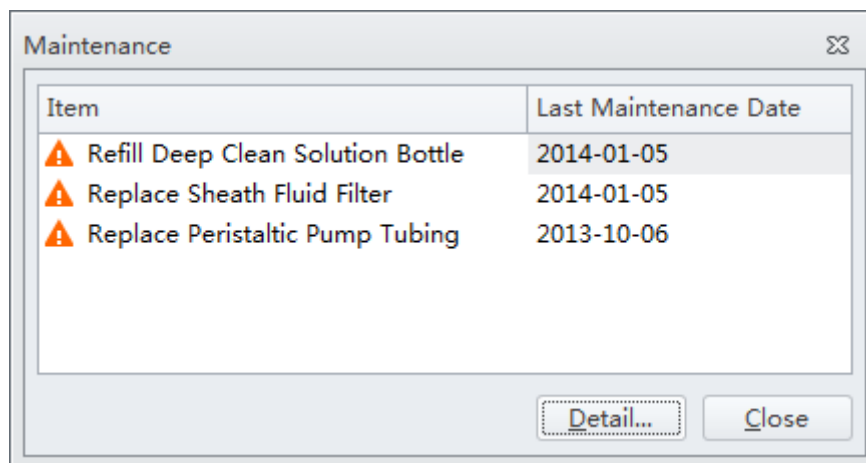
- Refill Deep Clean solution bottle (cleaning solution)
- Replace sheath fluid filter
- Replace sample peristaltic pump tubing

When reagents or parts have reached the designated use time limit in either days or number of uses, the Maintenance Message icon  appears in the right side of the status bar.

1 Select the Maintenance Message icon  from the status bar to access the Maintenance window. The expired item appears with a warning triangle  to the left of the item listed.

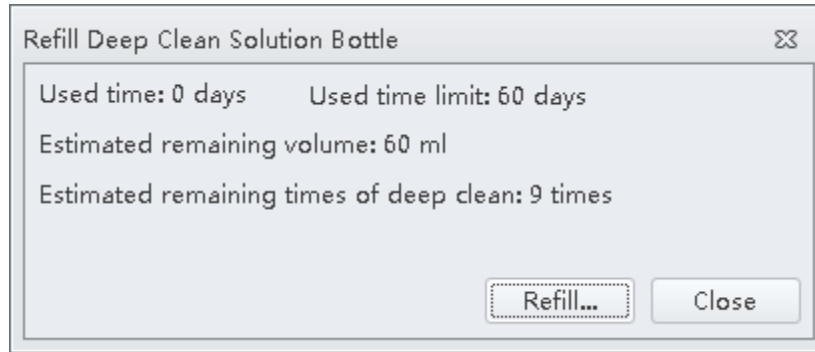
Or

Select **Maintenance** in the Advanced menu. The Maintenance window appears. The expired item is displayed with a warning triangle  to the left of the item listed.

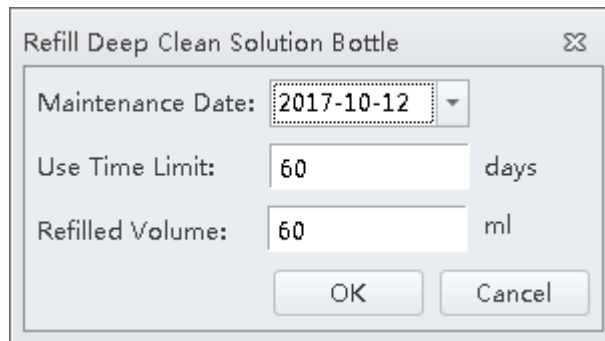


- 2 Select the desired item to manage, then choose one of the following:
- To manage refilling the Deep Clean solution bottle, go to Step 3.
  - To manage replacing the sheath filter, skip to Step 4.
  - To manage replacing the sample peristaltic pump tubing, skip to Step 5.

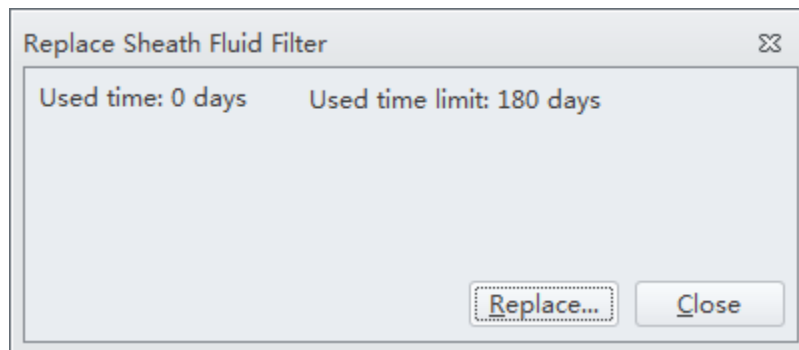
- 3 Select **Detail**. The Refill Deep Clean Solution Bottle window appears.



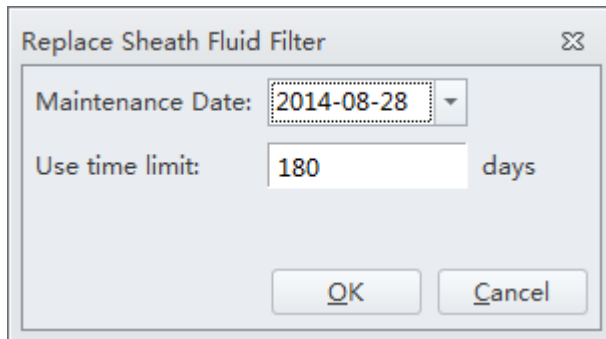
Select **Refill**. A pop-up window appears to reset the maintenance date as the current date that the maintenance was performed.



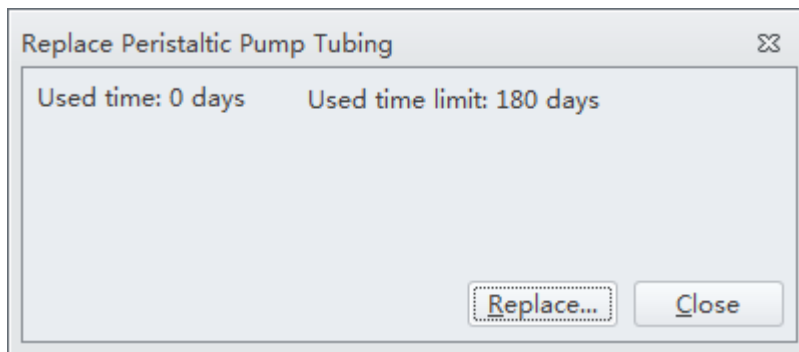
- 4 Select **Detail**. The Replace Sheath Fluid Filter window appears.



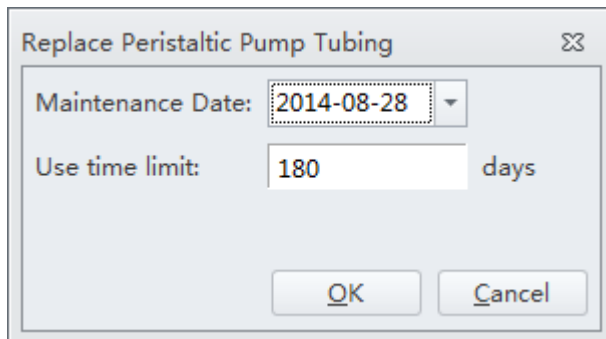
Select **Replace**. A pop-up window appears to reset the maintenance date as the current date that the maintenance was performed.



5 Select **Detail**. The Replace Peristaltic Pump Tubing window appears.



Select **Replace**. A pop-up window appears to reset the maintenance date as the current date that the maintenance was performed.



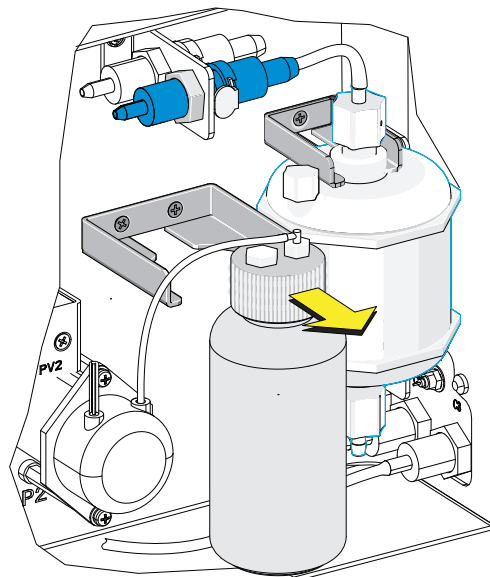
## Adding the Deep Clean Solution

Check occasionally whether the Deep Clean solution in the Deep Clean solution bottle is sufficient. Replace the Deep Clean solution when the maintenance reminder prompts you to do so.

**⚠ WARNING**

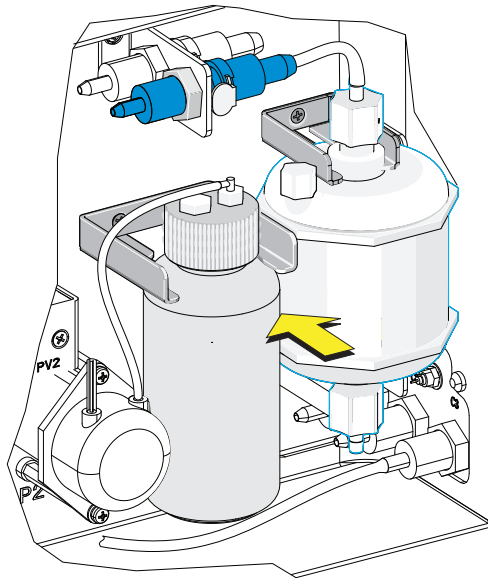
**Risk of chemical injury from Contrad 70 reagent. To avoid contact with the Contrad 70 reagent, use barrier protection, including protective eyewear, gloves, and suitable laboratory attire. Refer to the Safety Data Sheet for details about chemical exposure before using the chemical.**

- 1 Make 60 mL of Deep Clean solution by mixing 30 mL of Contrad 70 and 30 mL DI water in the Deep Clean solution bottle and swirl the solution gently to create the Deep Clean solution.
- 2 Verify that the Cytometer is in standby state or is turned off.
- 3 Remove the right-side cover of the instrument. Refer to [Right-Side Cover Removal and Reinstallation](#).
- 4 Remove the Deep Clean solution bottle and open the cap.



- 5 Add 60 mL Deep Clean solution to the bottle.

- 
- 6 Tighten the cap, and attach the Deep Clean solution bottle to the bracket.



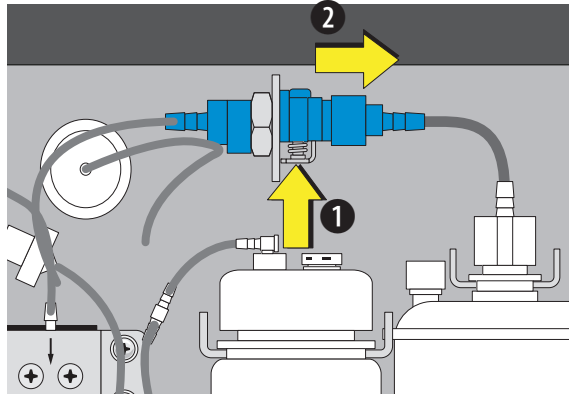
- 
- 7 Reinstall the right-side cover (see [Right-Side Cover Removal and Reinstallation](#)), and fasten the thumbscrews.
  - 8 Reset the maintenance reminder tracker. Refer to [Managing the Maintenance Reminder](#).
- 

## Replacing the Sheath Fluid Filter

It is recommended to replace the sheath fluid filter every six months when the maintenance reminder prompts you to do so. The life of the filter is related to the quality of the sheath fluid used. If it is found that there are impurities in the light scatter pattern, replace the sheath fluid filter.

- 
- 1 Select **Standby** on the left of the screen to place the instrument in standby state, or shut off the Cytometer's power.
  - 2 Remove the right-side cover. Refer to [Right-Side Cover Removal and Reinstallation](#).
-

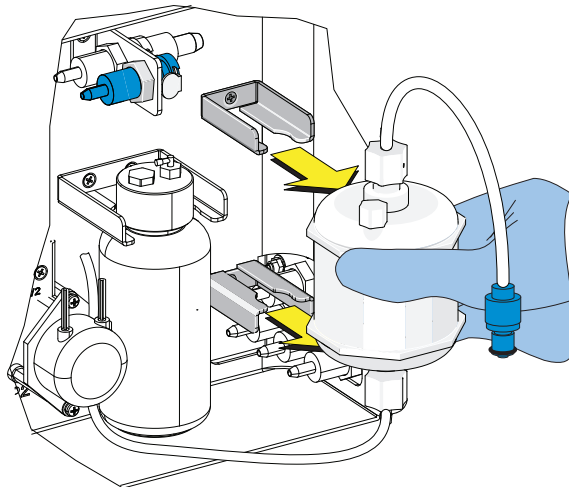
- 3 Press the spring piece on the quick connector and the Cytometer on the upper side of the filter, and disconnect the quick connector.



- 4 Repeat Step 3 for the quick connector behind the quick connector removed in the previous step.

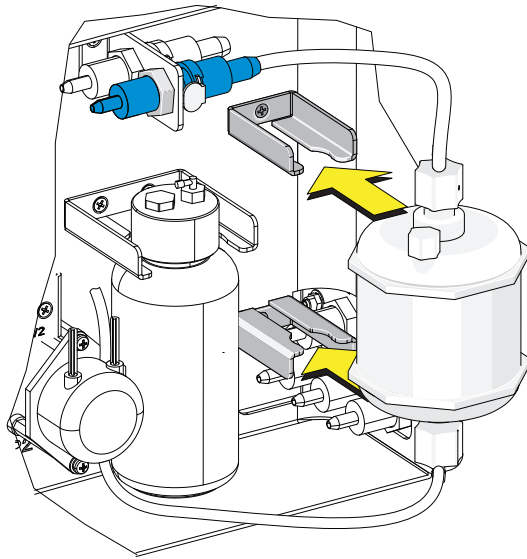
**NOTE** The spring is on the opposite side.

- 5 Remove the sheath fluid filter from the bracket.

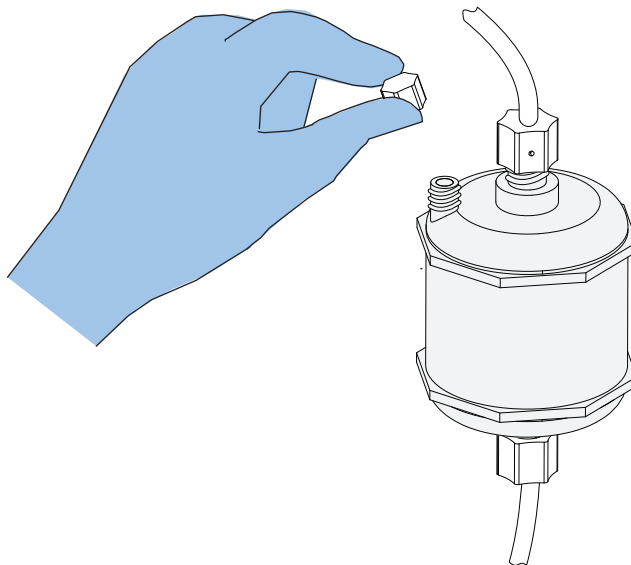


- 6 Connect the new, unused filter using the quick connector springs.

- 
- 7 Attach the filter to the filter bracket.



- 
- 8 Remove the vent cap and set it aside.



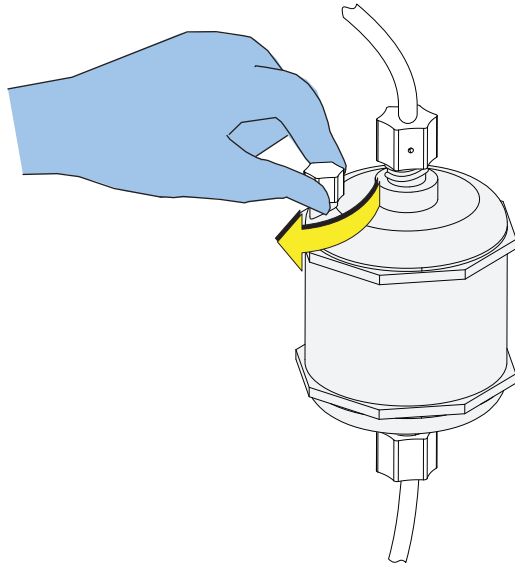
- 
- 9 Turn on the Cytometer and open the software.

- 
- 10 Select **Prime** in the Cytometer menu.

**CAUTION**

**Risk of instrument damage. If the vent cap is not sealed tightly, unstable flow rate and leakage of the sheath fluid can occur.**

- 11 Observe the liquid level in the filter during the prime cycle. When the liquid level reaches the upper section of the filter, reinstall the vent cap to prevent air leakage.



- 12 Reinstall the right-side cover (see [Right-Side Cover Removal and Reinstallation](#)) and lock the screw.
- 13 If the problem persists, [contact us](#).
- 14 Run the system startup program. Refer to [CHAPTER 4, Running the System Startup Program \[with the Single Tube Loader\]](#).
- 15 Reset the maintenance reminder tracker. Refer to [Managing the Maintenance Reminder](#).

## Unclogging the Sample Probe [With Sample Injection Mode Control Kit]

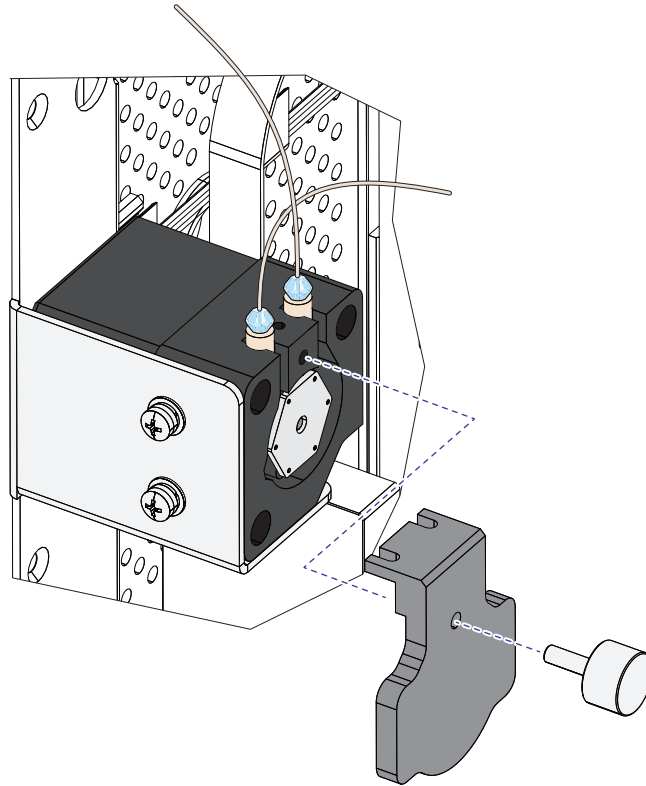


### **WARNING**

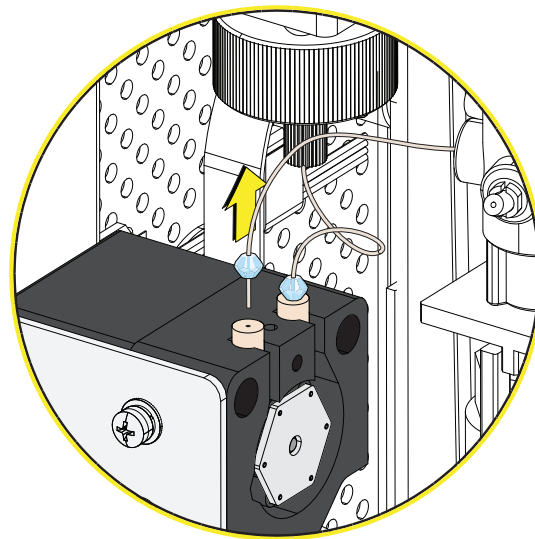
Risk of biohazardous contamination if you have skin contact with the sample probe or the sample peristaltic pump tubing. The sample probe and the sample peristaltic pump tubing could contain residual biological material and must be handled with care. Clean up spills immediately. Dispose of the sample probe and the sample peristaltic pump tubing in accordance with your local regulations and acceptable laboratory procedures.

- 1 Verify that the Cytometer is turned off.
- 2 Remove the right-side cover. Refer to [Right-Side Cover Removal and Reinstallation](#).
- 3 Remove the front cover. Refer to [Front Cover Removal and Reinstallation](#).

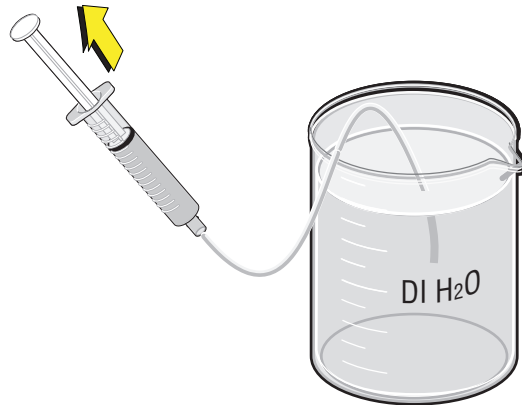
- 4 Remove the sample pump cover thumbscrew and the sample pump cover.



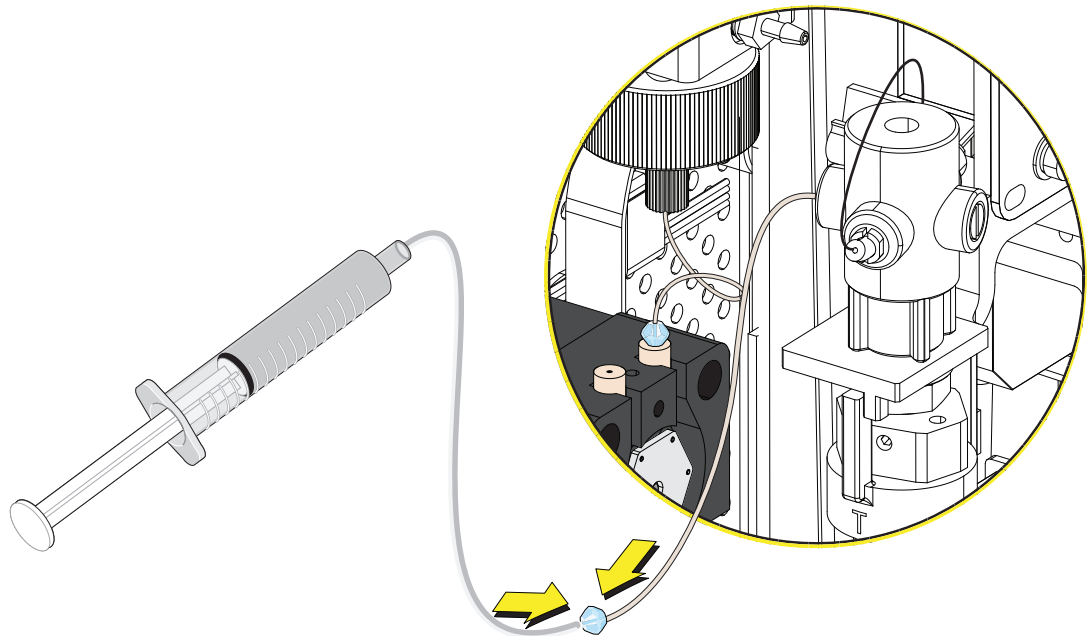
- 5 Remove the sample PEEK tubing from the sample peristaltic pump tubing.



- 6 Fill the sample line declog tool syringe with DI water.

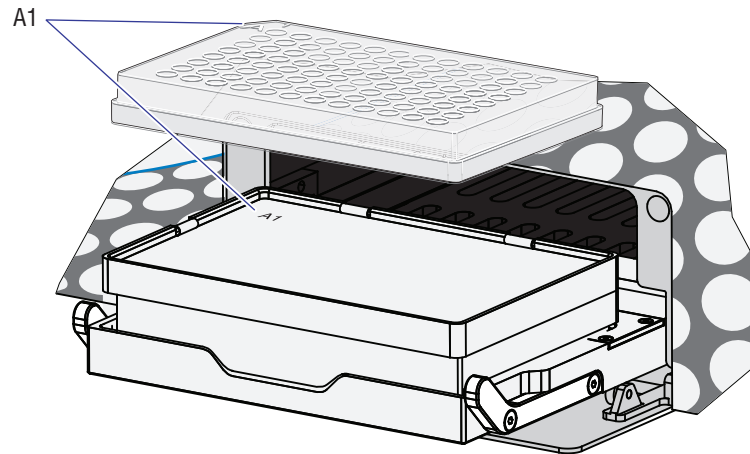


- 7 Use the sample line declog tool, connect the tool tip to the end of the PEEK tube.



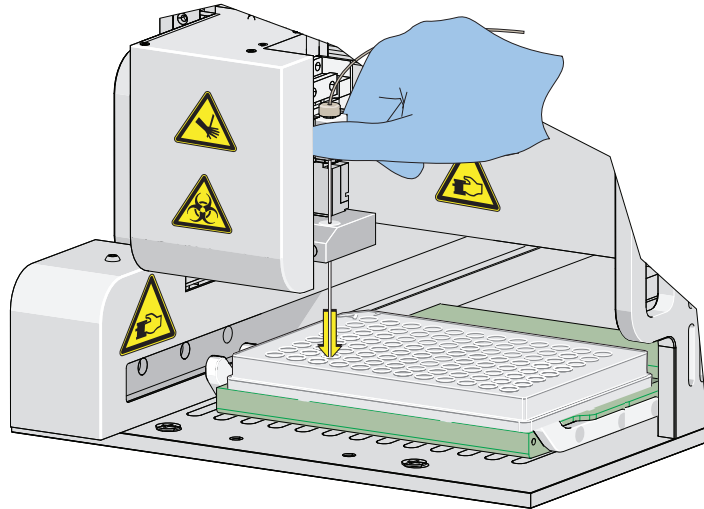
**8 [For Plate Loader Sample Probe]:**

- a. Place the plate on the plate holder.

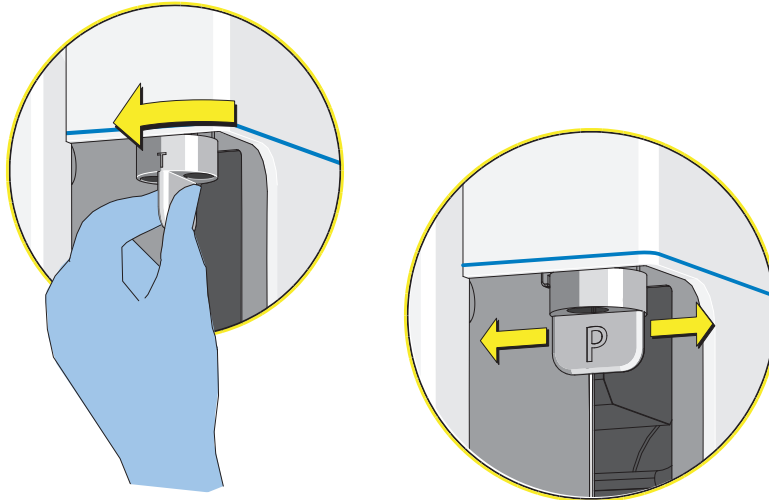


**NOTE** Ensure plate well A1 aligns with position A1.

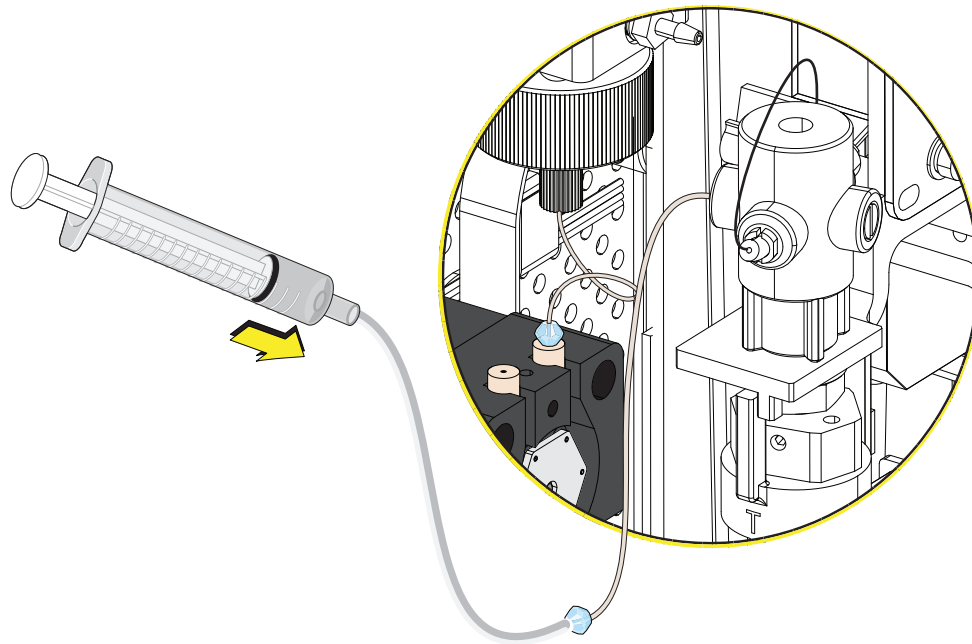
- b. Pull back the plate holder and insert the sample probe into any well manually.



- c. Turn the switch module knob to the left until the flat side of the knob is parallel to the front panel and the **P** is facing you. Ensure that the knob is turned as far as it will go.



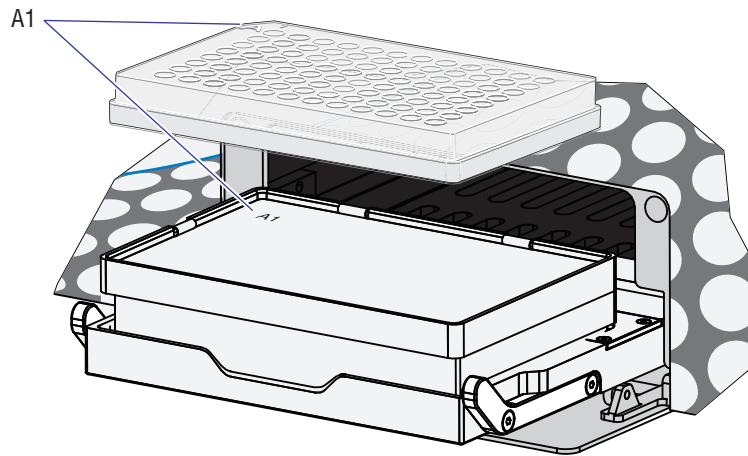
- d. Gently squeeze the DI water into the plate.



Verify whether the DI water is dripping or spraying from the sample probe.

- If yes, the sample probe is un-clogged. Proceed to next step.
- If no dripping water or you cannot squeeze the syringe, the sample probe is severely clogged and you need to replace the sample probe. For instructions, refer to [Replacing the Sample Probe and/or the Sample Peristaltic Pump Tubing](#).

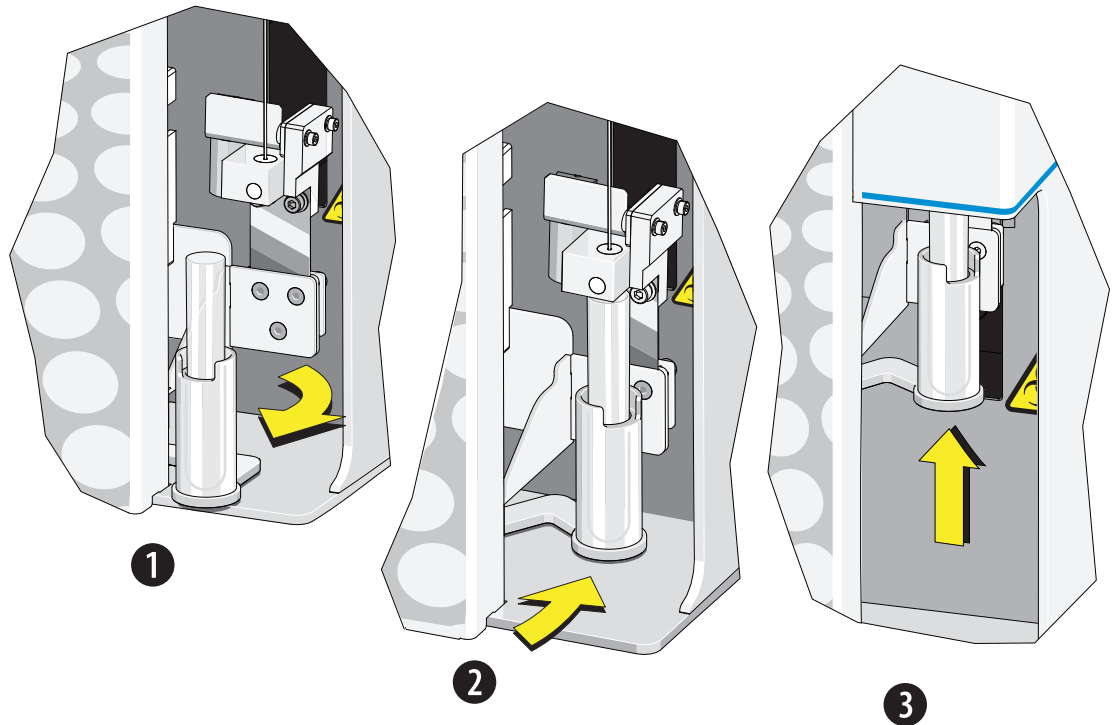
- e. Remove plate from tube holder.



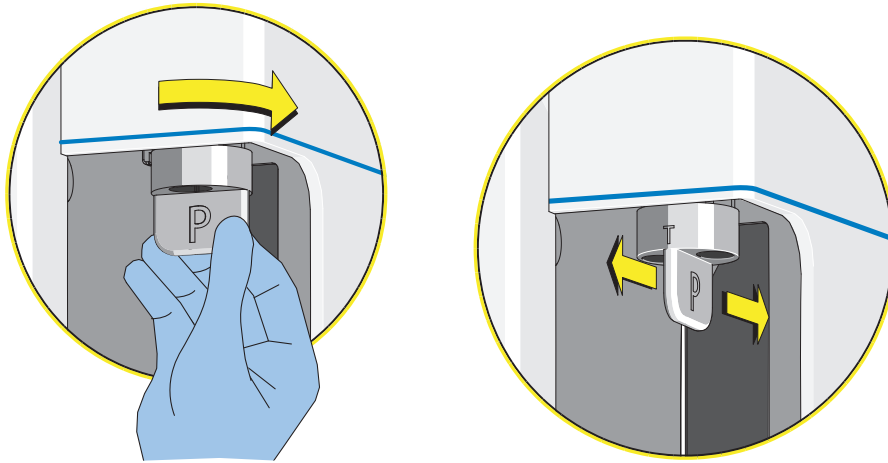
- f. Skip to Step 10.

**9 [For Sample Injection Mode Control Kit Sample Probe]:**

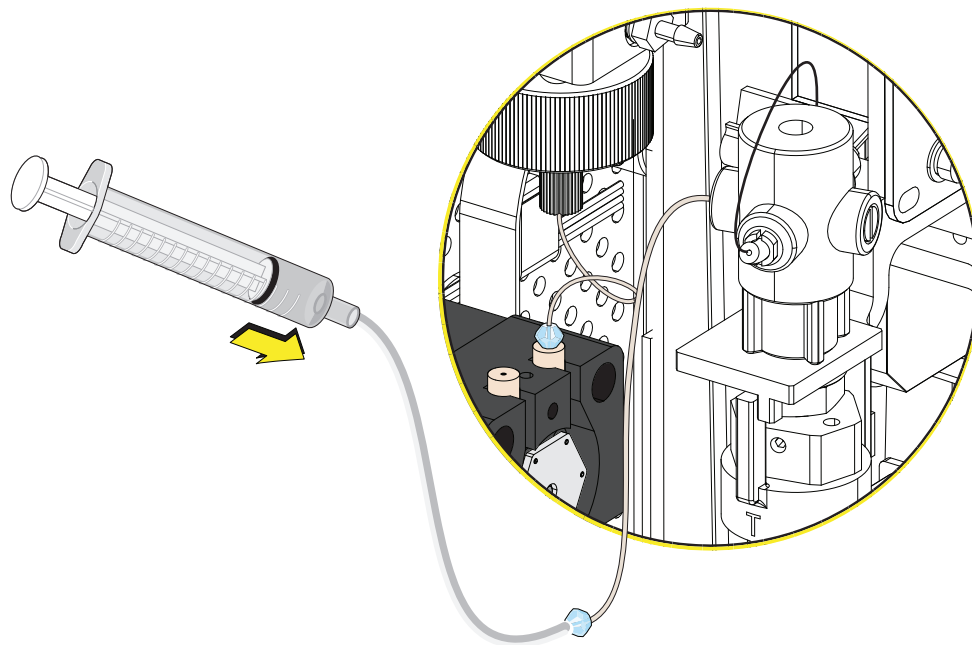
- a. Pull out the tube holder manually. Place an empty tube in tube holder. Push back tube holder and lift the tube holder so the sample probe is inside the sample tube.



- b. Turn the switch module knob to the right until the flat side of knob is perpendicular to the front panel and the T is facing you. Ensure that the knob is turned as far as it will go.



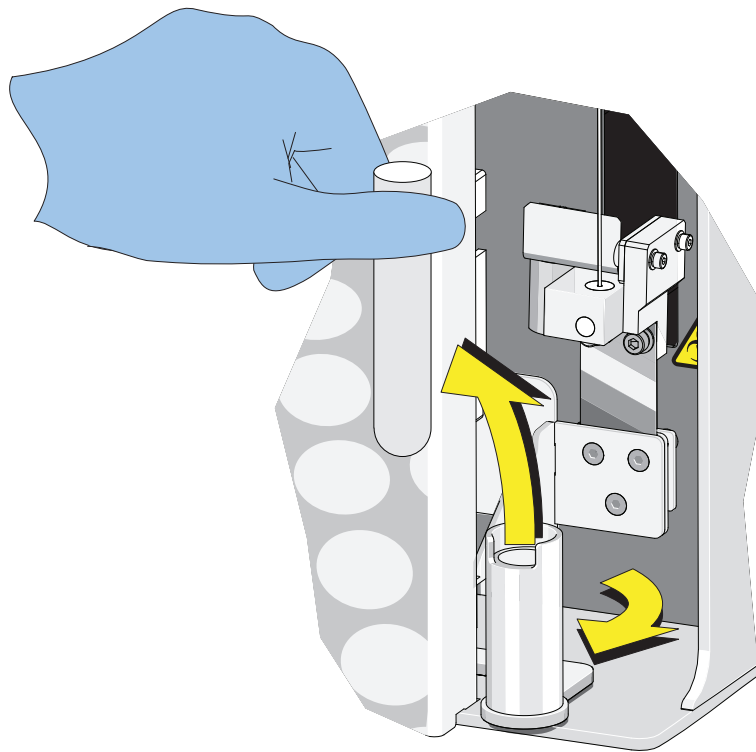
- c. Gently squeeze the DI water into the tubing.



Verify whether the DI water is dripping or spraying from the sample probe.

- If yes, the sample probe is un-clogged. Proceed to Step 10.
- If no dripping water or you cannot squeeze the syringe, the sample probe is severely clogged and you need to replace the sample probe. For instructions, refer to [Replacing the Sample Probe and/or the Sample Peristaltic Pump Tubing](#).

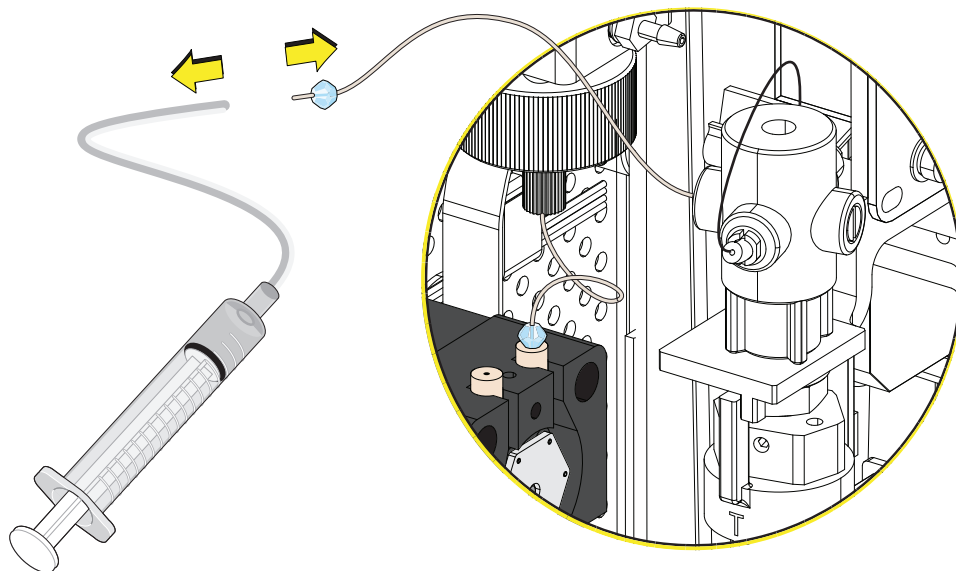
- d. Remove the tube from tube holder.



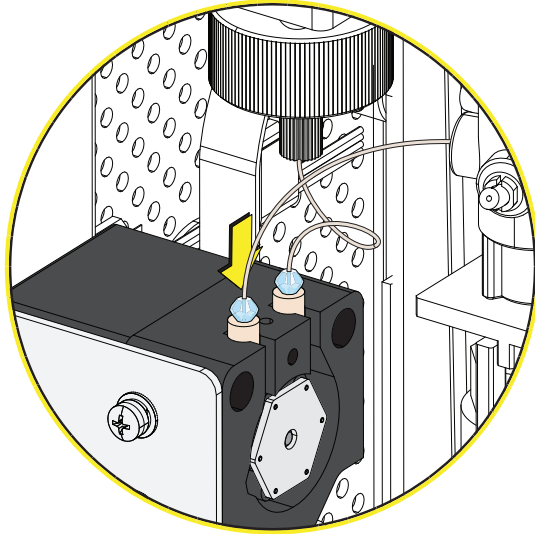
- e. Proceed to Step 10.

---

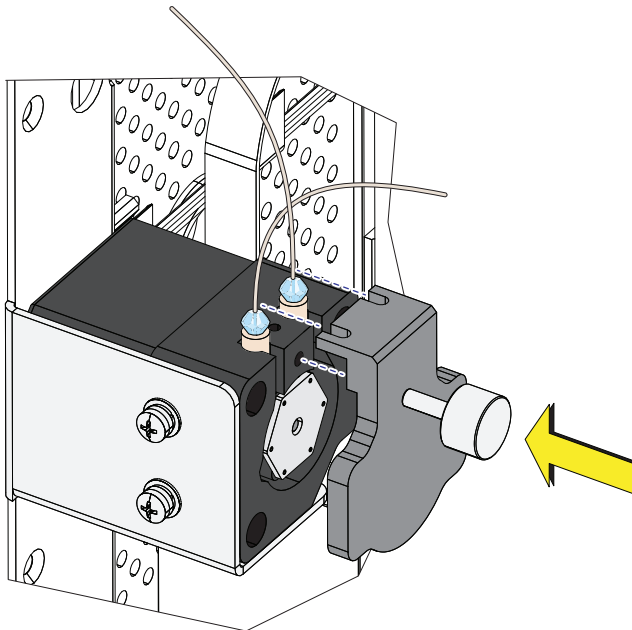
**10** Disconnect the tool tip and the PEEK tube.



- 11** Connect the PEEK tubing to the sample peristaltic pump tubing.



- 12** Install the sample pump cover.



- 13** Reinstall the right-side cover (see [Right-Side Cover Removal and Reinstallation](#)), and lock with the screw.

- 14** Reinstall the front cover. Refer to [Front Cover Removal and Reinstallation](#).

- 
- 15 Start the software. Turn on the instrument. Refer to [CHAPTER 4, Daily Startup](#).

---

  - 16 Select **Initialize** from the Cytometer Menu or select **Initialize** in the Data Acquisition Control screen.

---

  - 17 Select **Backflush** from the Cytometer Menu or select **Backflush** in the Data Acquisition Control screen.
- 

## Unclogging the Sample Probe [Without Sample Injection Mode Control Kit]



### **WARNING**

Risk of biohazardous contamination if you have skin contact with the sample probe or the sample peristaltic pump tubing. The sample probe and the sample peristaltic pump tubing could contain residual biological material and must be handled with care. Clean up spills immediately. Dispose of the sample probe and the sample peristaltic pump tubing in accordance with your local regulations and acceptable laboratory procedures.

- 
- 1 Verify that the Cytometer is turned off.

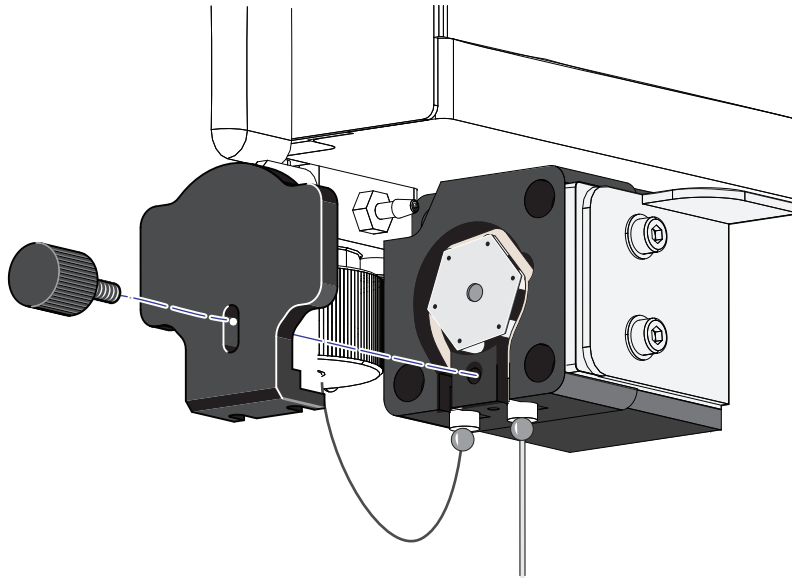
---

  - 2 Remove the right-side cover. Refer to [Right-Side Cover Removal and Reinstallation](#).

---

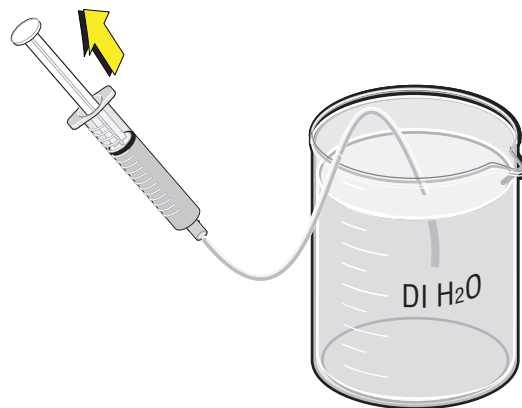
  - 3 Remove the front cover. Refer to [Front Cover Removal and Reinstallation](#).

- 
- 4 Remove the sample pump cover thumbscrew and the sample pump cover.

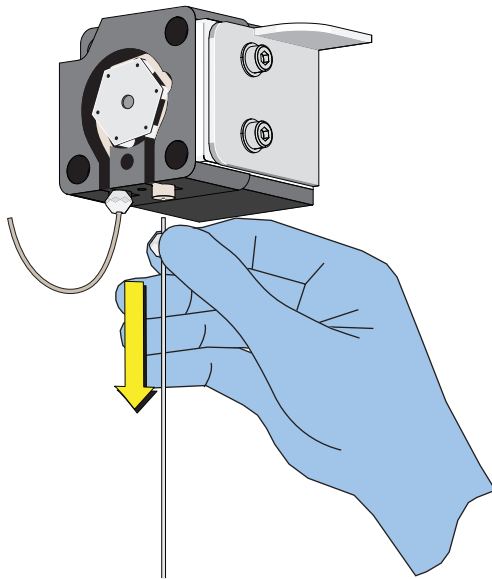


- 
- 5 [For Single Tube Sample Station]:

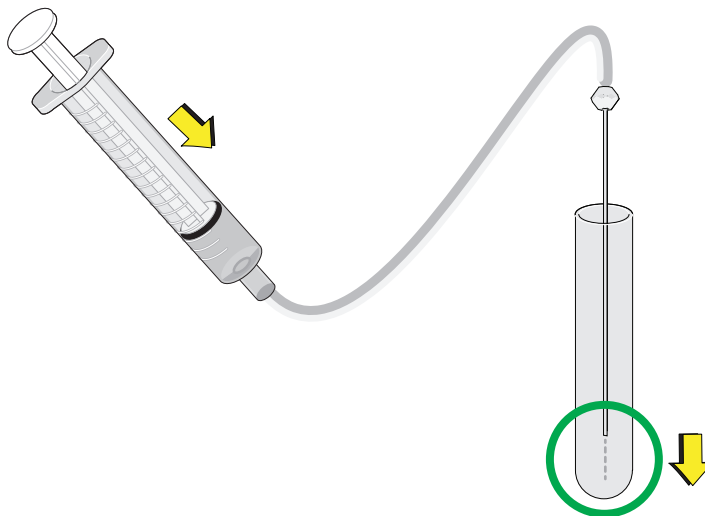
- a. Fill the sample line declog syringe with DI water.



- b. Remove the sample probe from the single tube sample station.



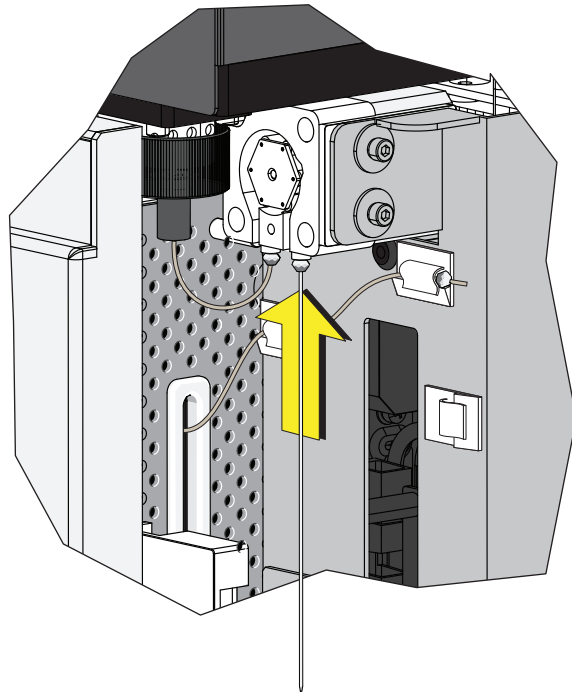
- c. Connect the tool to the end of the sample probe, gently squeeze the DI water into an empty tube.



Verify whether the DI water is dripping or spraying from the sample probe.

- If yes, the sample probe is un-clogged. Proceed to next step.
- If no dripping water or you cannot squeeze the syringe, the sample probe is severely clogged and you need to replace the sample probe. For instructions, refer to [Replacing the Sample Probe and/or the Sample Peristaltic Pump Tubing](#).

- d. Disconnect the sample probe from the declog tool. Connect the sample probe to the sample peristaltic pump tubing.

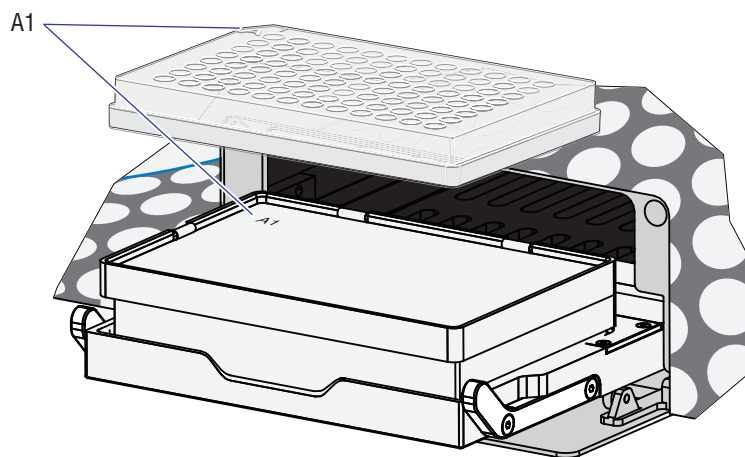


- e. Skip to Step 7.

---

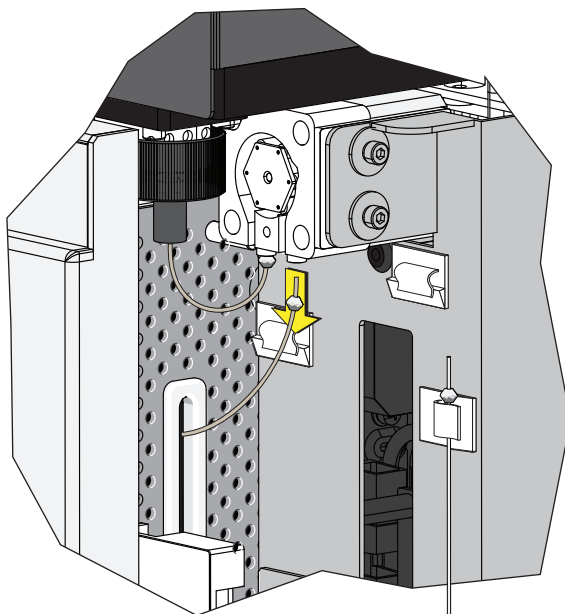
**6** [For Plate Loader]:

- a. Place the plate on the plate holder.



**NOTE** Ensure plate well A1 aligns with position A1.

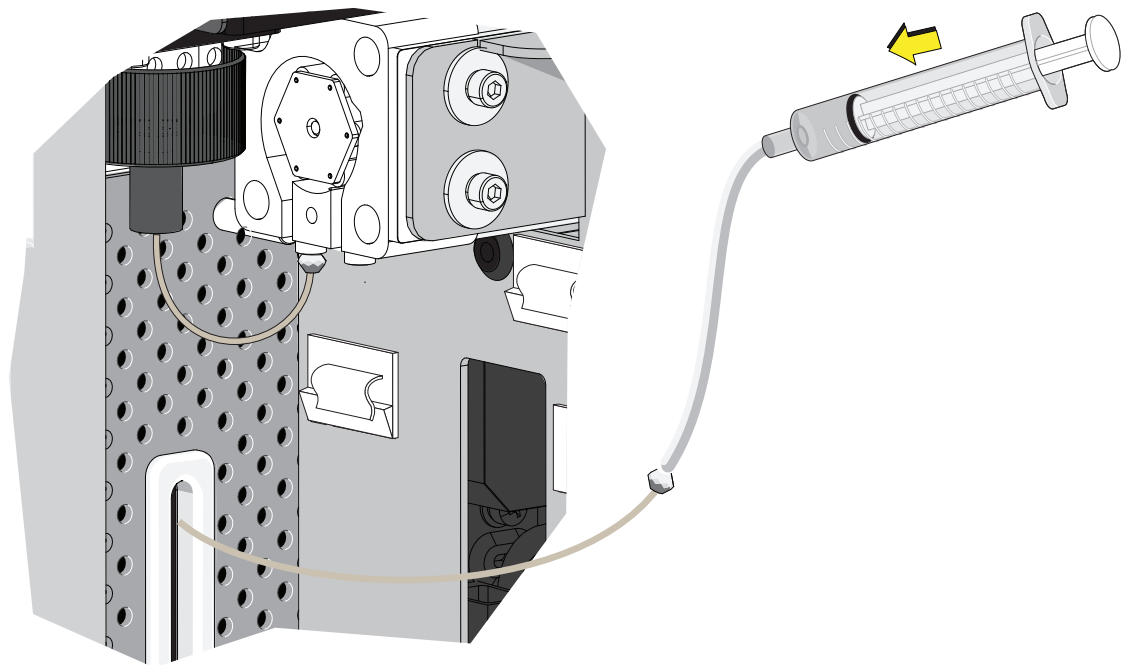
- b. Remove the plate loader PEEK tubing from the sample peristaltic pump tubing.



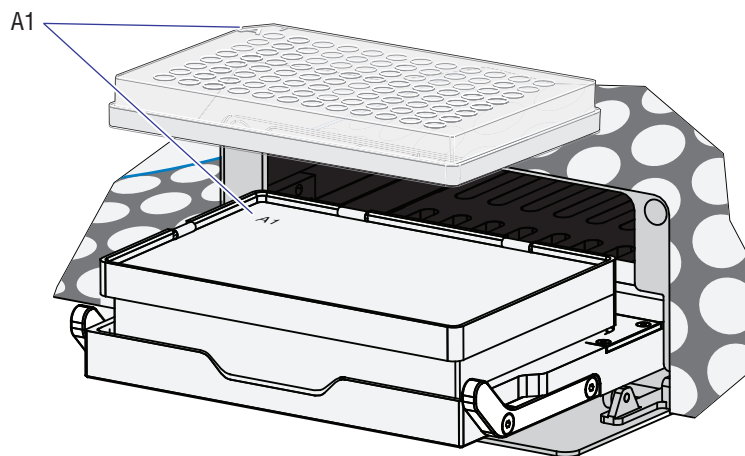
- c. Fill the sample line declog tool syringe with DI water.



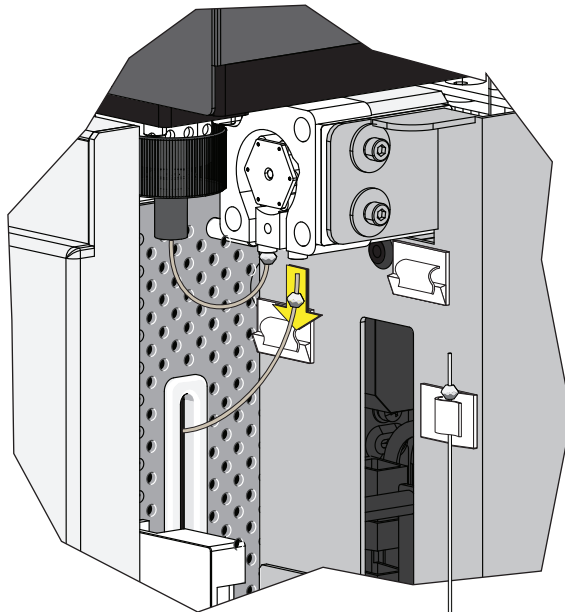
- d. Use the sample line declog tool, connect the tool tip to the end of the PEEK tube.



- e. Gently squeeze the DI water into the plate. Verify whether the DI water is dripping or spraying from the sample probe.
- If yes, the sample probe is un-clogged. Proceed to Step 7.
  - If no dripping water or you cannot squeeze the syringe, the sample probe is severely clogged and you need to replace the sample probe. For instructions, refer to [Replacing the Sample Probe and/or the Sample Peristaltic Pump Tubing](#).
- f. Disconnect the Peek tube from the Declog tool.
- g. Remove plate from tube holder.



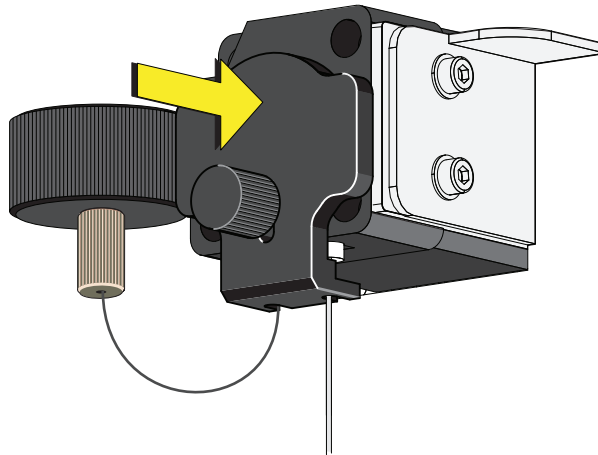
- h. Connect the plate loader PEEK tubing to the sample peristaltic pump tubing.



- i. Proceed to Step 7.

---

**7** Reinstall the sample pump cover.



**NOTE** To ensure the proper placement of the sample probe, push the sample pump cover up while installing the thumbscrew.

---

**8** Reinstall the right-side cover (see [Right-Side Cover Removal and Reinstallation](#)), and lock with the screw.

---

**9** Reinstall the front cover. Refer to [Front Cover Removal and Reinstallation](#).

- 10 Start the software. Turn on the instrument. Refer to [CHAPTER 4, Daily Startup](#).
- 11 Select **Initialize** from the Cytometer Menu or select **Initialize** in the Data Acquisition Control screen.
- 12 Select **Backflush** from the Cytometer Menu or select **Backflush** in the Data Acquisition Control screen.

## Replacing the Sample Probe and/or the Sample Peristaltic Pump Tubing



### **WARNING**

**Risk of biohazardous contamination if you have skin contact with the sample probe or the sample peristaltic pump tubing. The sample probe and the sample peristaltic pump tubing could contain residual biological material and must be handled with care. Clean up spills immediately. Dispose of the sample probe and the sample peristaltic pump tubing in accordance with your local regulations and acceptable laboratory procedures.**

**IMPORTANT** Replace the sample probe only if it is bent or severely clogged. Beckman Coulter recommends unclogging the sample probe before attempting to replace the sample probe. For instruction on unclogging sample probe, refer to [Unclogging the Sample Probe \[With Sample Injection Mode Control Kit\]](#) or [Unclogging the Sample Probe \[Without Sample Injection Mode Control Kit\]](#).

**IMPORTANT** If you need to replace the single tube sample probe assembly and you have the Sample Injection Mode Control Kit installed on your CytoFLEX instrument, pull the probe out of the CytoFLEX Sample Injection Mode Control Kit and push the new probe into place.

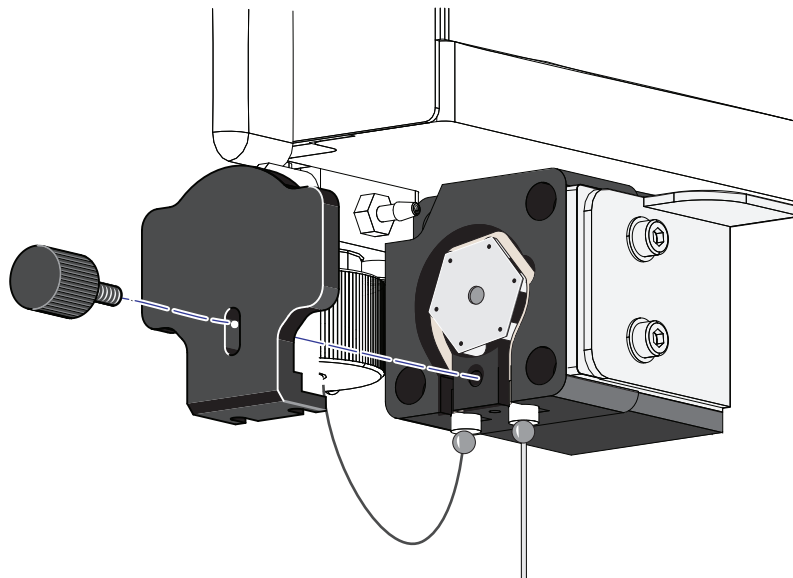
Beckman Coulter recommends replacing the tubing of the sample peristaltic pump every six months, or sooner. High sample volume, degradation of the stability of the sample flow, and increase of the CV may indicate the need to replace the tubing more frequently.

**NOTE** Ensure you replace the sample probe with a sample probe that has the same color jewel.

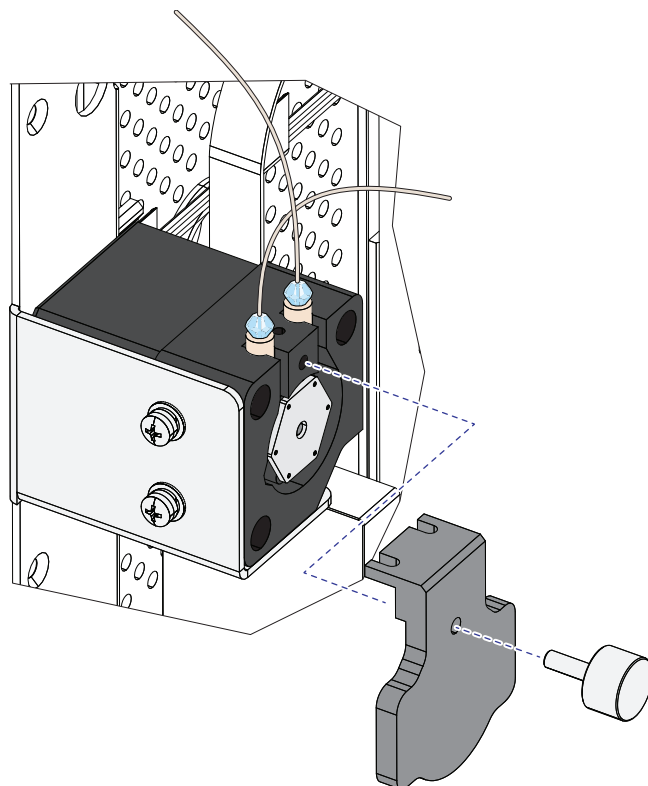
- 1 Place the instrument in standby state.
- 2 Remove the right-side cover. Refer to [Right-Side Cover Removal and Reinstallation](#).
- 3 Remove the front cover. Refer to [Front Cover Removal and Reinstallation](#).

- 4 Remove the sample pump cover thumbscrew and the sample pump cover.

**[Without Sample Injection Mode Control Kit]**

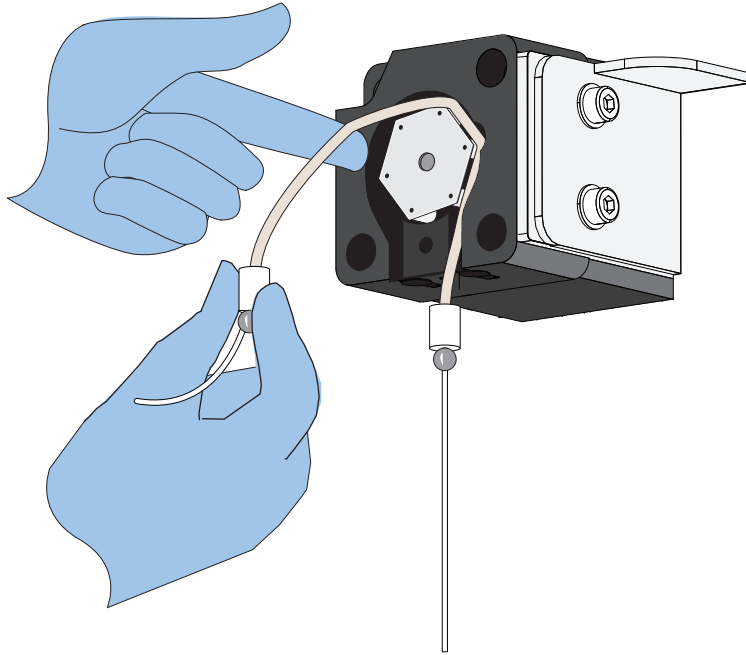


**[With Sample Injection Mode Control Kit]**

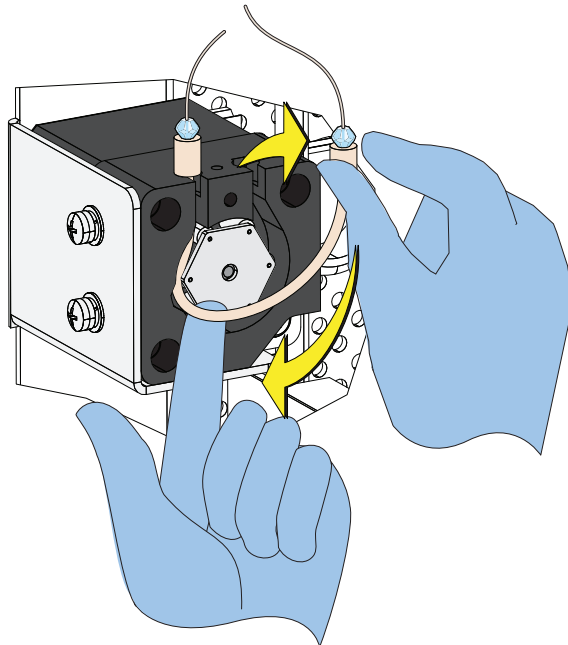


- 5 Take out the sample peristaltic pump tubing.

[Without Sample Injection Mode Control Kit]



[With Sample Injection Mode Control Kit]

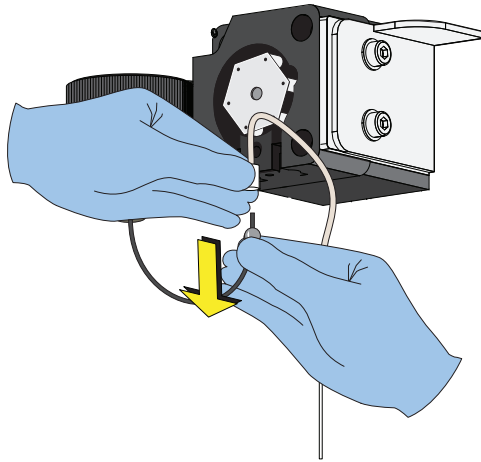


**⚠ CAUTION**

**Risk of optical misalignment. Removing the PEEK tubing from the bottom of the flow cell could cause misalignment of the optical components. Do not remove the PEEK tubing from the bottom of the flow cell.**

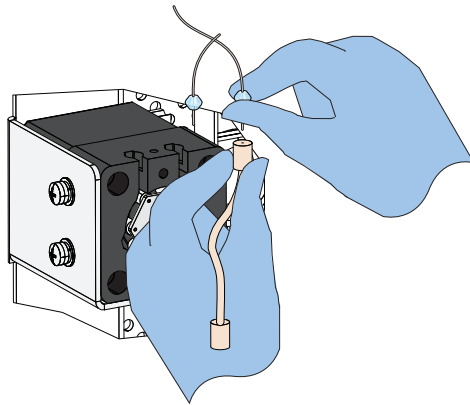
- 6 Remove the sample PEEK tubing from the sample peristaltic pump tubing.

[Without Sample Injection Mode Control Kit]



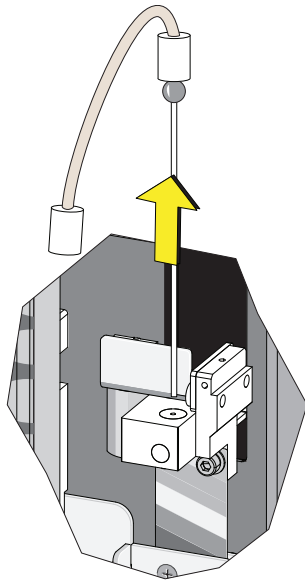
[Without Sample Injection Mode Control Kit]: Proceed to Step 7.

[With Sample Injection Mode Control Kit]

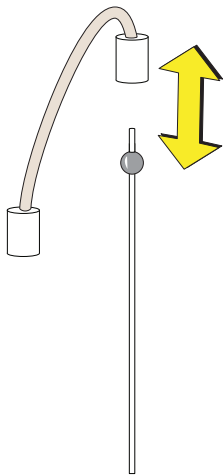


[With Sample Injection Mode Control Kit]: Skip to Step 9.

- 7** [Without Sample Injection Mode Control Kit]: Lift the sample probe out of the wash station.

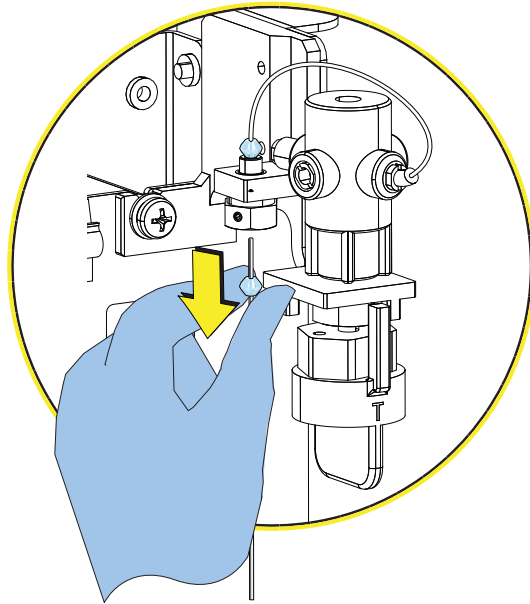


- 8** [Without Sample Injection Mode Control Kit]: Remove the sample peristaltic pump tubing from the sample probe.



Skip to Step 10.

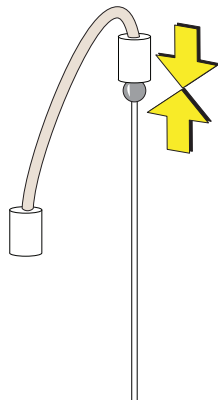
- 9** [With Sample Injection Mode Control Kit]: Remove the sample probe from the metal block if you need replace the sample probe.



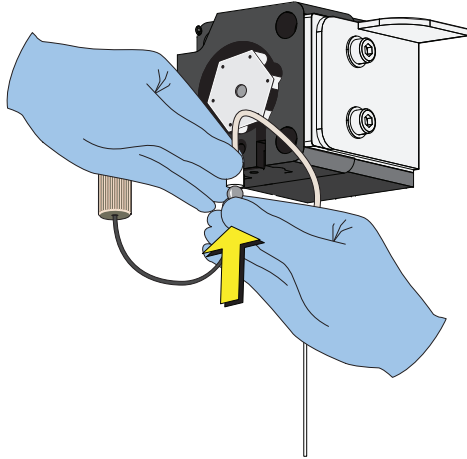
Proceed to Step 10.

- 10** Dispose of the old sample probe and/or sample peristaltic pump tubing in accordance with your local regulations and acceptable laboratory procedures.  
 [Without Sample Injection Mode Control Kit]: Proceed to Step 11.  
 [With Sample Injection Mode Control Kit]: Skip to Step 13.

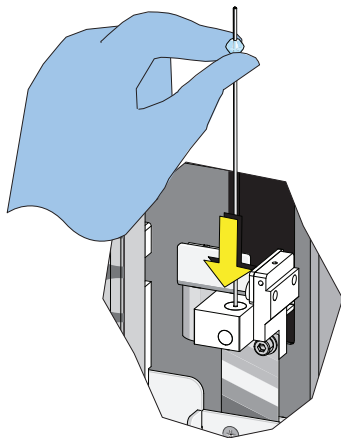
- 11** [Without Sample Injection Mode Control Kit]: Connect the sample peristaltic pump tubing to the sample probe.



- 12** [Without Sample Injection Mode Control Kit]: Connect the sample PEEK tubing to the sample peristaltic pump tubing.

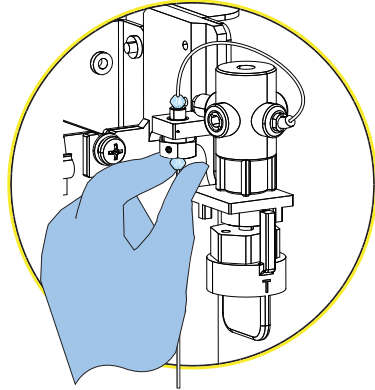


- 13** [With and Without Sample Injection Mode Control Kit]: Slide the sample probe into the wash station.



[Without Sample Injection Mode Control Kit]: Skip to Step 15.  
[With Sample Injection Mode Control Kit]: Proceed to Step 14.

- 14** [With Sample Injection Mode Control Kit]: Connect the sample probe to the metal block.

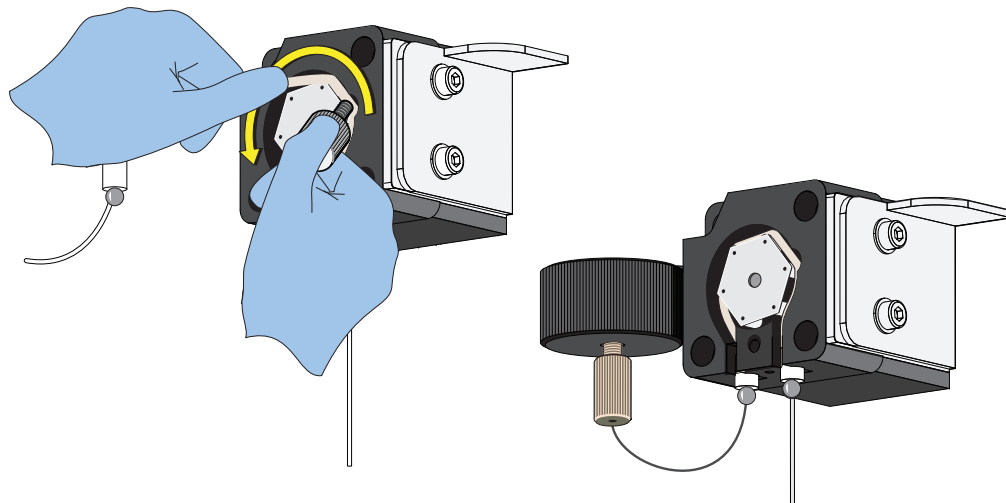


Proceed to Step 15.

- 15** Install the sample peristaltic pump tubing, taking care not to use any sharp tools, ensuring that the tube is fully inserted into the groove.

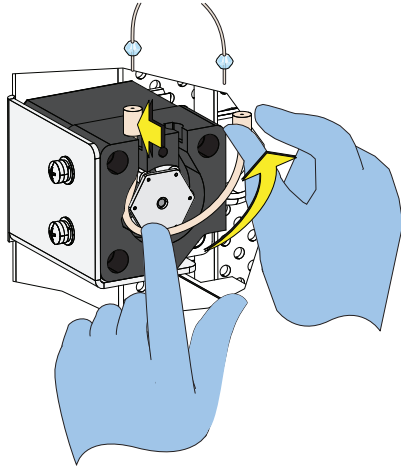
**NOTE** Use the sample pump cover thumbscrew to insert the sample peristaltic pump tubing into the groove while rotating the sample pump.

[Without Sample Injection Mode Control Kit]



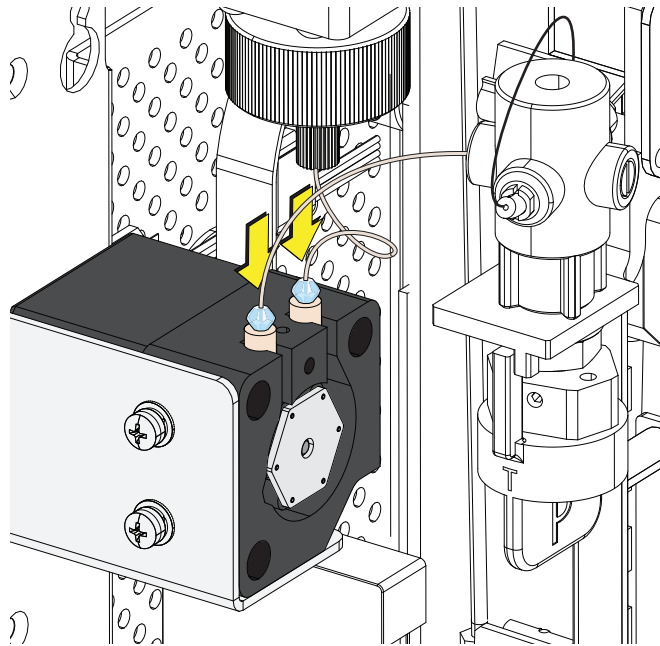
[Without Sample Injection Mode Control Kit]: Skip to Step 17.

[With Sample Injection Mode Control Kit]



[With Sample Injection Mode Control Kit]: Proceed to Step 16.

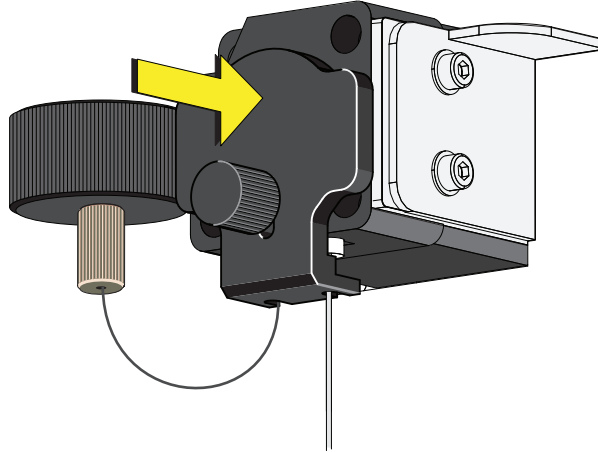
**16** [With Sample Injection Mode Control Kit]: Connect the PEEK tubing to the sample peristaltic pump tubing.



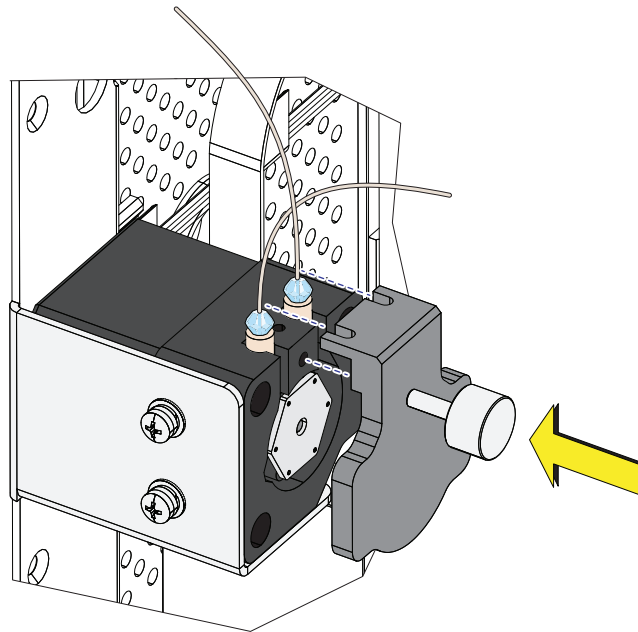
Proceed to Step 17.

**17** Install the sample pump cover.

[Without Sample Injection Mode Control Kit]



[With Sample Injection Mode Control Kit]



**NOTE** To ensure the proper placement of the sample probe, push the sample pump cover up while installing the thumbscrew.

[With and Without Sample Injection Mode Control Kit]: Proceed to Step 18.

**18** Reinstall the right-side cover (see [Right-Side Cover Removal and Reinstallation](#)), and lock with the screw.

## Replacing the Sample Probe Assembly [With Plate Loader]

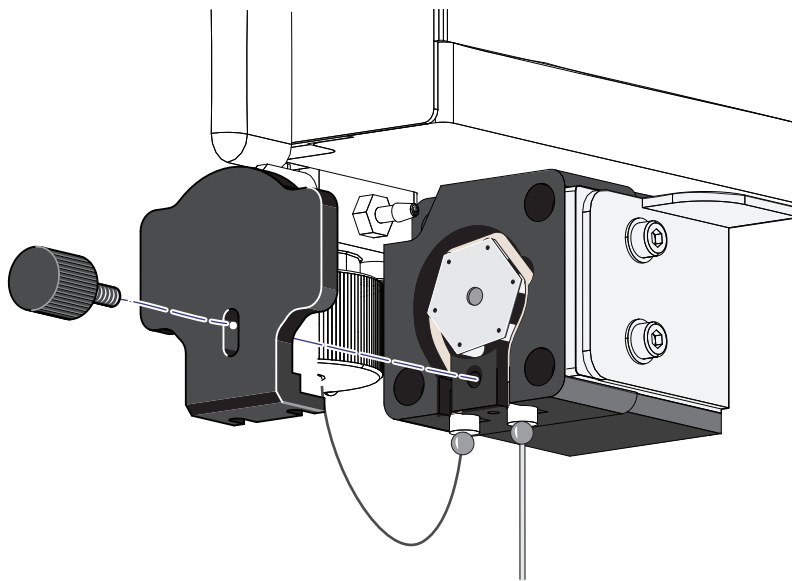


**IMPORTANT** If you have the Sample Injection Mode Control Kit installed on your CytoFLEX flow cytometer, [contact us](#) to replace the sample probe assembly.

### **WARNING**

Risk of biohazardous contamination if you have skin contact with the sample probe or the sample peristaltic pump tubing. The sample probe and the sample peristaltic pump tubing could contain residual biological material and must be handled with care. Clean up spills immediately. Dispose of the sample probe and the sample peristaltic pump tubing in accordance with your local regulations and acceptable laboratory procedures.

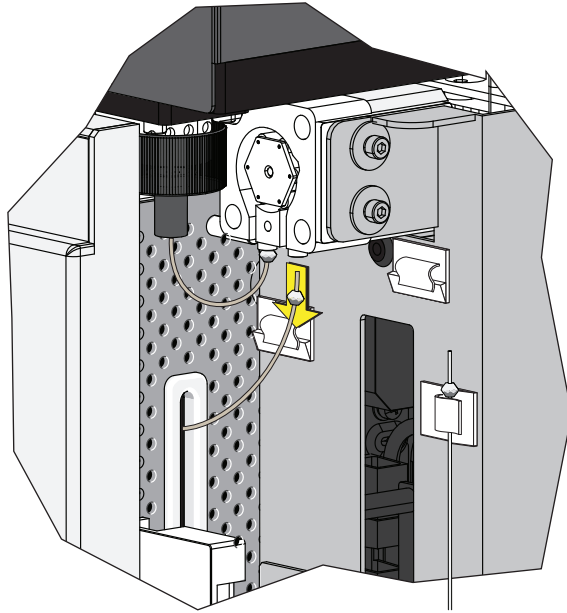
- 1 Turn the Cytometer's main power switch off.
- 2 Remove the right-side cover. Refer to [CHAPTER 12, Right-Side Cover Removal and Reinstallation](#).
- 3 Remove the front cover. Refer to [CHAPTER 12, Front Cover Removal and Reinstallation](#).
- 4 Remove the sample pump cover thumbscrew and the sample pump cover.



**CAUTION**

**Risk of optical misalignment. Removing the PEEK tubing from the bottom of the flow cell could cause misalignment of the optical components. Do not remove the PEEK tubing from the bottom of the flow cell.**

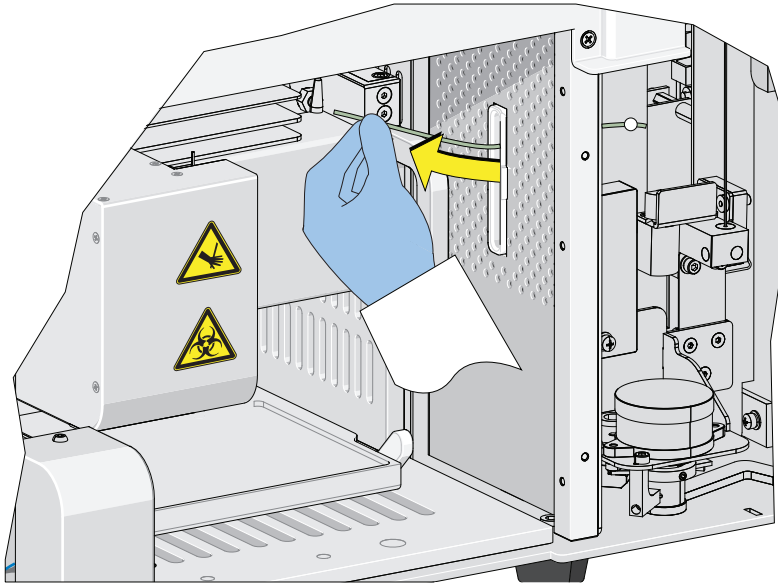
- 5 Remove the plate loader PEEK tubing from the sample peristaltic pump tubing.



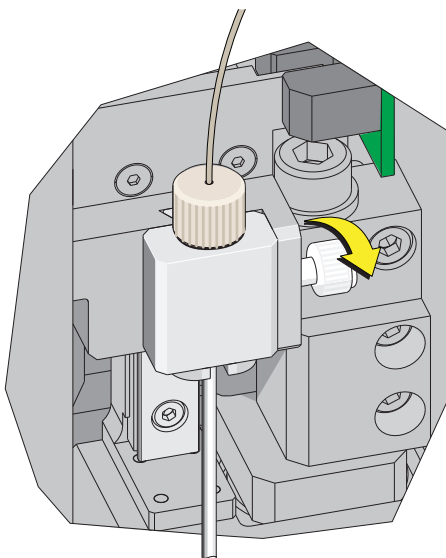
**CAUTION**

The plate loader PEEK tubing can be deformed, which could affect sample flow. When routing the plate loader PEEK tubing to and from the Sample Station, be careful not to pinch, crimp, stretch, or break the tubing.

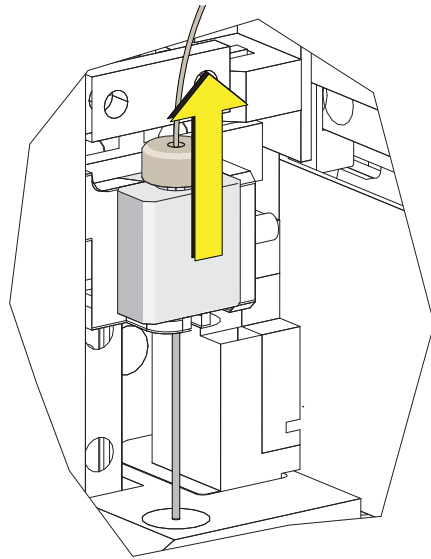
- 6 Pull the plate loader PEEK tubing through the slot so the tubing sits inside the instrument.



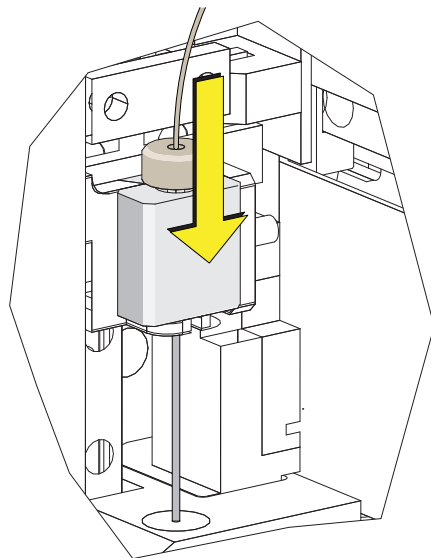
- 7 Loosen the white plastic thumbscrew behind the plate loader sample probe.



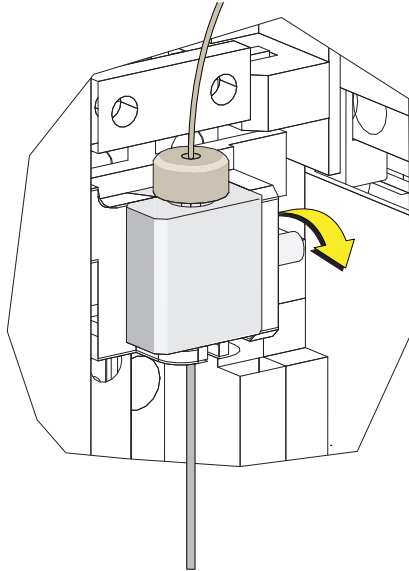
- 8 Lift the plate loader sample probe assembly straight up to remove it from the probe holder.



- 9 Align the tongue on the plate loader sample probe assembly with the groove in the probe holder and slide the probe down until it is flush with the probe holder.



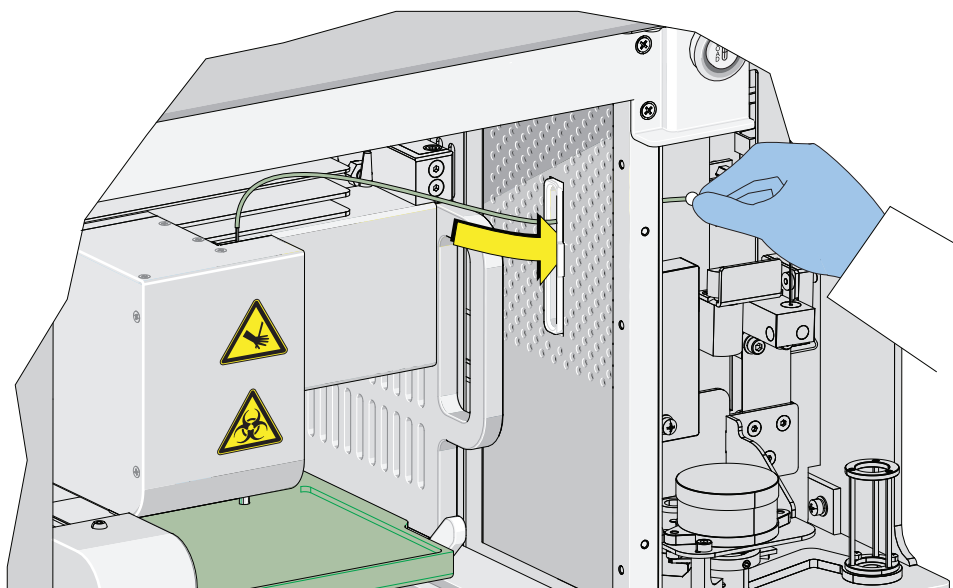
- 10 Tighten the white plastic thumbscrew.



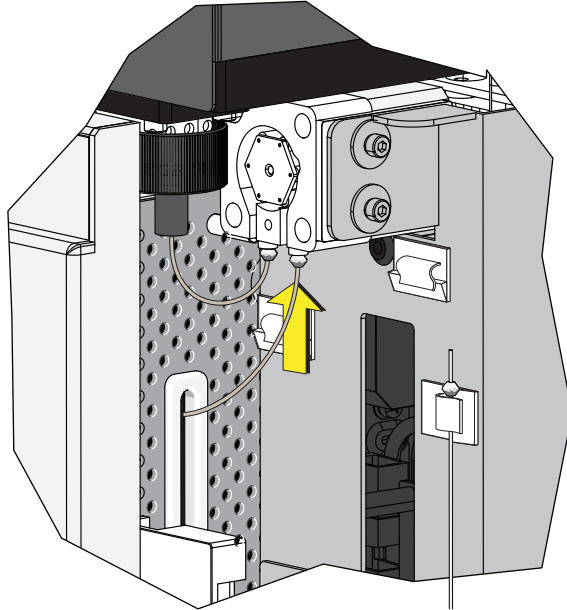
**CAUTION**

The plate loader PEEK tubing can be deformed which could affect sample flow. When routing the plate loader PEEK tubing to and from the Sample Station, be careful not to pinch, crimp, stretch, or break the tubing.

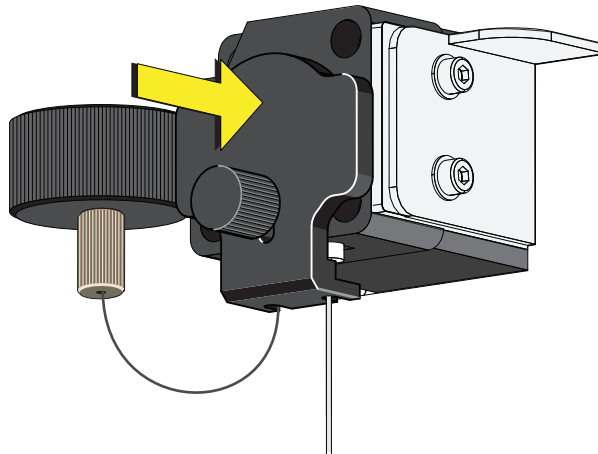
- 11 Slide the new plate loader PEEK tubing through the slot into the single tube sample station area.



- 
- 12** Connect the sample peristaltic pump tubing to the plate loader PEEK tubing.



- 
- 13** Install the sample pump cover.



**NOTE** To ensure the proper placement of the sample probe, push the sample pump cover up while installing the thumbscrew.

- 
- 14** Reinstall the right-side cover (refer to [CHAPTER 12, Right-Side Cover Removal and Reinstallation](#)), and lock with the screw.

- 
- 15** Close the top cover.

- 
- 16 Turn the Cytometer's main power switch on.
- 

## Changing the Sample Probe from the Single Tube Sample Station to the Plate Loader [CytoFLEX With Plate Loader]



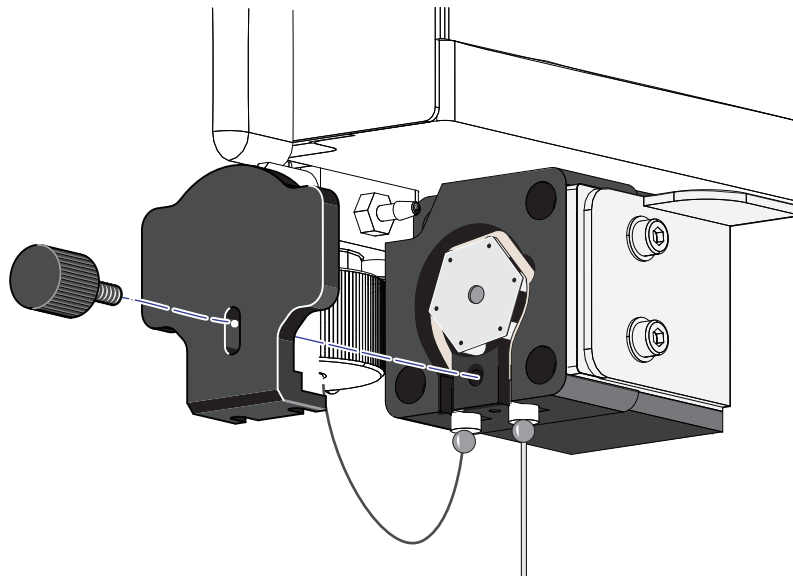
### **WARNING**

**Risk of biohazardous contamination if you have skin contact with the sample probe or the sample peristaltic pump tubing. The sample probe and the sample peristaltic pump tubing could contain residual biological material and must be handled with care. Clean up spills immediately.**

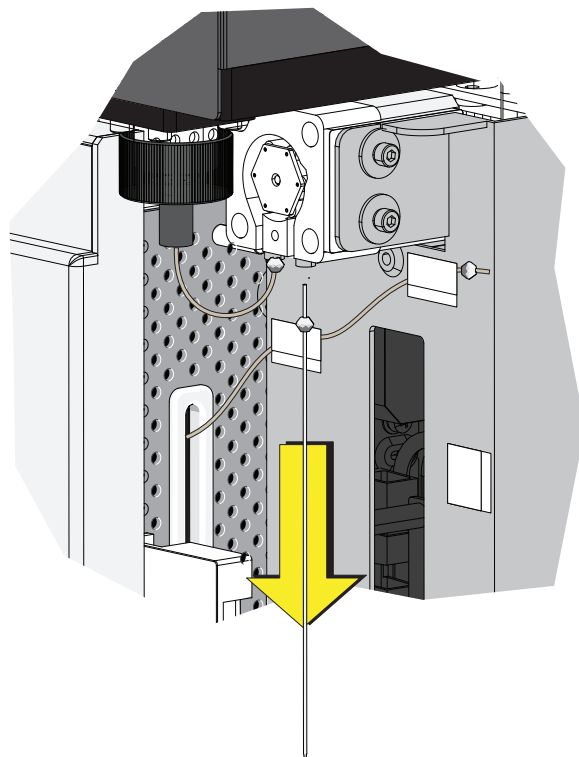
**NOTE** If you have the Sample Injection Mode Control Kit installed on your CytoFLEX flow cytometer, refer to [APPENDIX C, Switching the Sample Probe from the Single Tube Sample Station to the Plate Loader \[With Sample Injection Mode Control Knob\]](#) for instructions on switching between the single tube mode and the plate loader mode.

- 
- 1 Switch to the Plate Loader sample injection mode. Refer to [CHAPTER 4, Selecting the Plate Loader Sample Injection Mode \[With Plate Loader\]](#).
  - 2 Lift the top cover.
  - 3 Remove the right-side cover. Refer to [CHAPTER 12, Right-Side Cover Removal and Reinstallation](#).
  - 4 Remove the front cover. Refer to [CHAPTER 12, Front Cover Removal and Reinstallation](#).
-

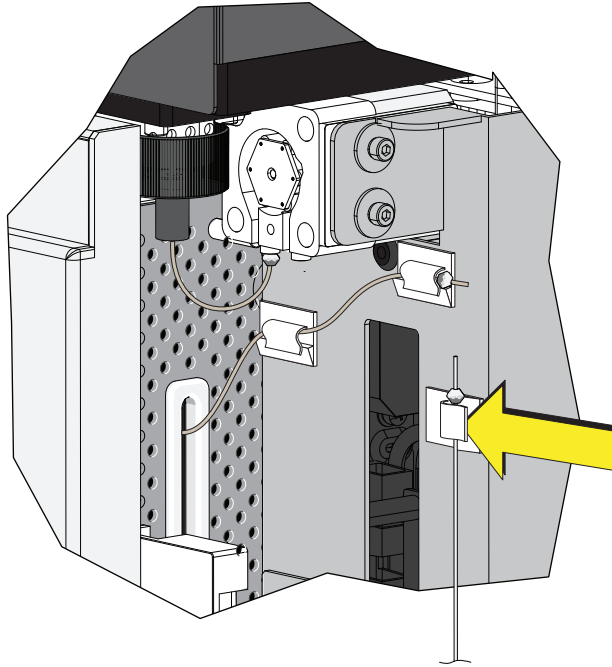
- 5 Remove the sample pump cover thumbscrew and the sample pump cover.



- 6 Remove the sample probe from the single tube sample station.



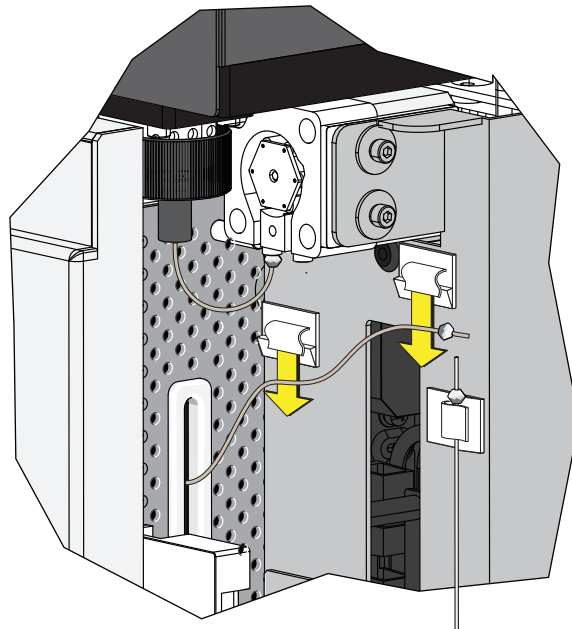
- 7 Place the sample probe in the white clip located on the right side of the sample station.



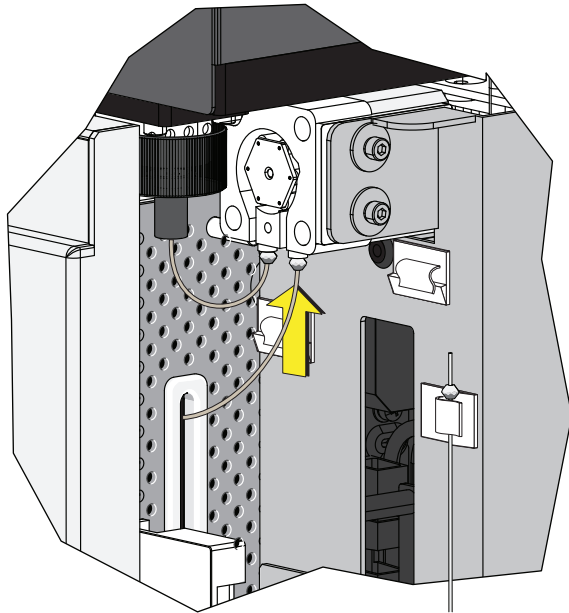
**CAUTION**

The plate loader PEEK tubing can be deformed which could affect sample flow. When removing the plate loader PEEK tubing from the white clips, be careful not to pinch, crimp, stretch, or break the tubing.

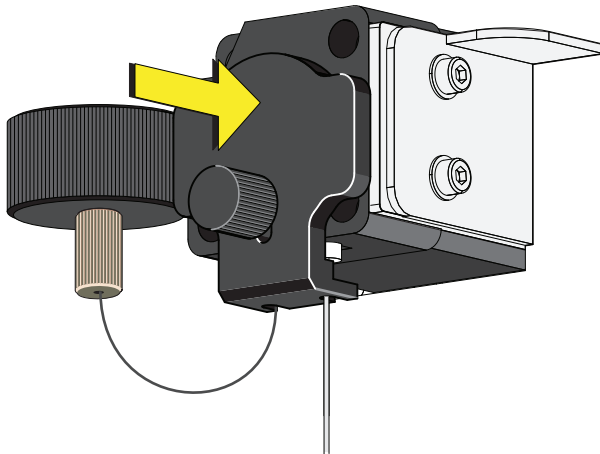
- 8 Remove the plate loader PEEK tubing from the two white clips located at the top of the sample station.



- 
- 9 Connect the plate loader PEEK tubing to the sample peristaltic pump tubing.



- 
- 10 Reinstall the sample pump cover.



**NOTE** To ensure the proper placement of the sample probe, push the sample pump cover up while installing the thumbscrew.

- 
- 11 Reinstall the right-side cover (refer to [CHAPTER 12, Right-Side Cover Removal and Reinstallation](#)), and lock with the screw.

- 
- 12 Close the top cover.

- 
- 13 Turn the Cytometer's main power switch on.
- 

## Changing the Sample Probe from the Plate Loader to the Single Tube Sample Station [CytoFLEX With Plate Loader]



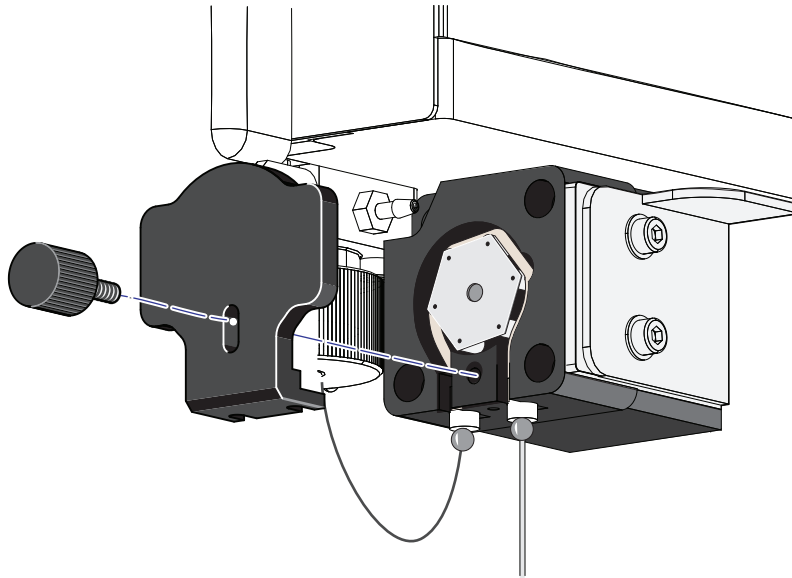
### WARNING

Risk of biohazardous contamination if you have skin contact with the sample probe or the sample peristaltic pump tubing. The sample probe and the sample peristaltic pump tubing could contain residual biological material and must be handled with care. Clean up spills immediately.

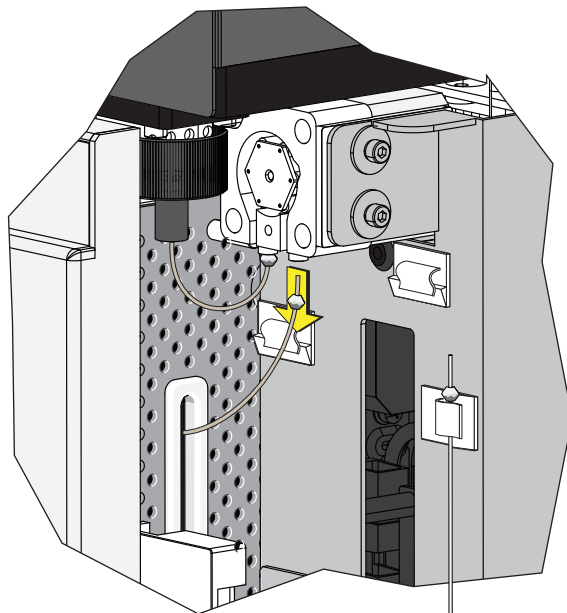
**NOTE** If you have the Sample Injection Mode Control Kit installed on your CytoFLEX flow cytometer, refer to [APPENDIX C, Switching the Sample Probe from the Plate Loader to the Single Tube Sample Station \[With Sample Injection Mode Control Knob\]](#) for instructions on switching between the single tube mode and the plate loader mode.

- 
- 1 Switch to either the Semi-Automatic or manual sample injection mode. Refer to [CHAPTER 4, Selecting the Proper Sample Injection Mode](#).
- 
- 2 Lift the top cover.
- 
- 3 Remove the right-side cover. Refer to [CHAPTER 12, Right-Side Cover Removal and Reinstallation](#).
- 
- 4 Remove the front cover. Refer to [CHAPTER 12, Front Cover Removal and Reinstallation](#).

- 
- 5 Remove the sample pump cover thumbscrew and the sample pump cover.



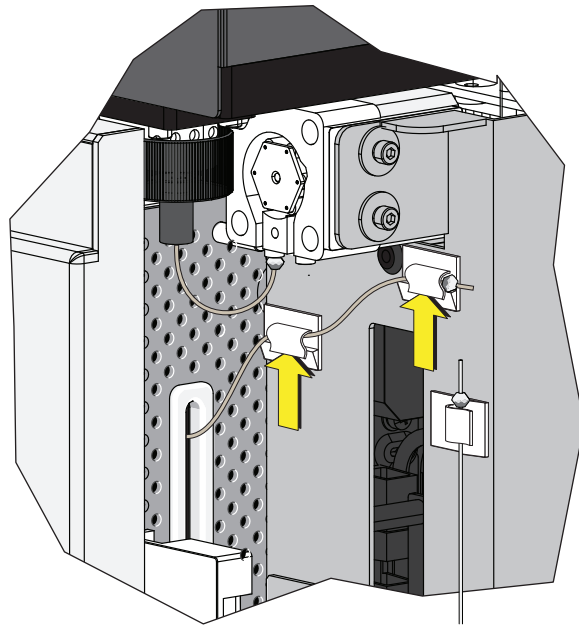
- 
- 6 Remove the plate loader PEEK tubing from the sample peristaltic pump tubing.



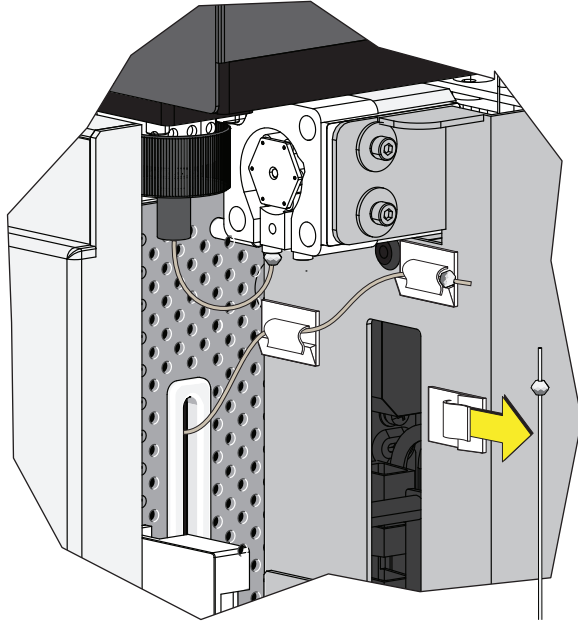
**CAUTION**

The plate loader PEEK tubing can be deformed, which could affect sample flow. When placing the plate loader PEEK tubing in the white clips, be careful not to pinch, crimp, stretch, or break the tubing.

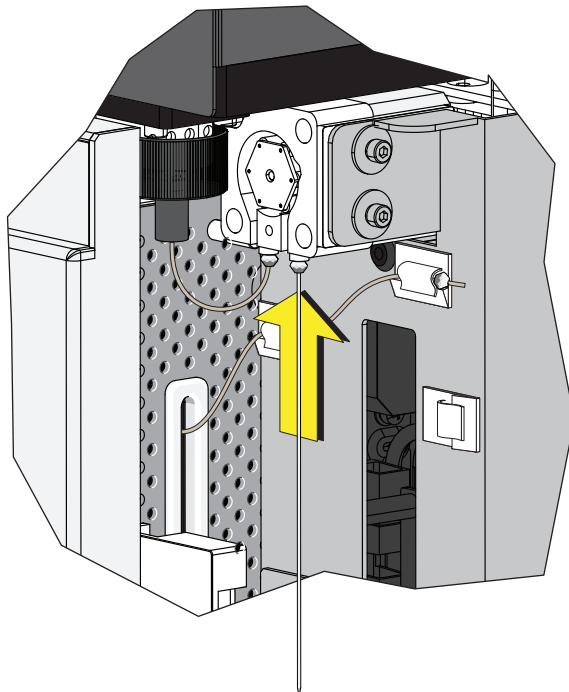
- 7 Place the plate loader PEEK tubing in the two white clips located at the top of the sample station.



- 8 Remove the sample probe from the white clip located on the right side of the sample station.



- 9 Connect the sample probe to the sample peristaltic pump tubing.



- 
- 10 Run [CHAPTER 11, Daily Clean](#).
- 

## Inspecting the Liquid Flow Path for Leaks

 **WARNING**

The liquid flow tubing can be aged and cracked or the connector can be loosened. Liquid leakage can lead to biological harm. To reduce occurrence of such problems, carry out liquid flow tubing inspection every six months and ensure that the Fluidics module functions without any leaks. If any leaks are found when using the Cytometer, stop the experiment immediately and look for the source of the leak.

- 
- 1 Remove the right-side cover of the instrument. Refer to [Right-Side Cover Removal and Reinstallation](#).
  - 2 Perform instrument initialization to enable the sheath fluid to flow. Refer to [CHAPTER 4, Initializing the Instrument](#).
  - 3 Check the connectors and tubes in the Fluidics module, and check whether any liquid leaks out.
  - 4 Check the sheath fluid, backflush, and waste liquid connector on the back of the Cytometer, and check whether any liquid leaks out.
  - 5 Place the instrument in standby state, complete the priming procedure, and check whether the Fluidics module has any liquid leakage.
  - 6 If any liquid leaks out and the point of liquid leakage is from the filter, try to tighten the filter connector and check again. If the problem persists, replace the sheath fluid filter.
  - 7 If any liquid leaks out from any other connector or tube, stop running the instrument and [contact us](#).
-

## Priming the Flow Cell

Priming of the flow cell is required when:

- The instrument is not used for a long period of time.
- The sheath fluid is refilled.
- The instrument is being used for the first time.
- The signal of the instrument is poor or the signal drifts.
- The sheath filter is replaced.

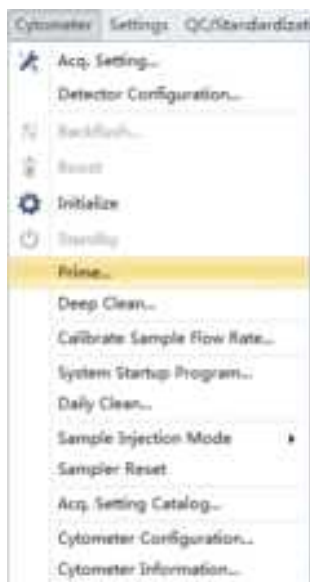
---

**1** Ensure that the instrument is in standby state.

**NOTE** If the instrument is not already in the standby state, select **Standby** from the Cytometer Menu or select **Standby** in the Data Acquisition Control screen.

---

**2** Select **Prime** from the Cytometer Menu to prime the flow cell. Wait for the beep and for the Instructions window to close.



Otherwise, look for the status bar to display that priming has completed.



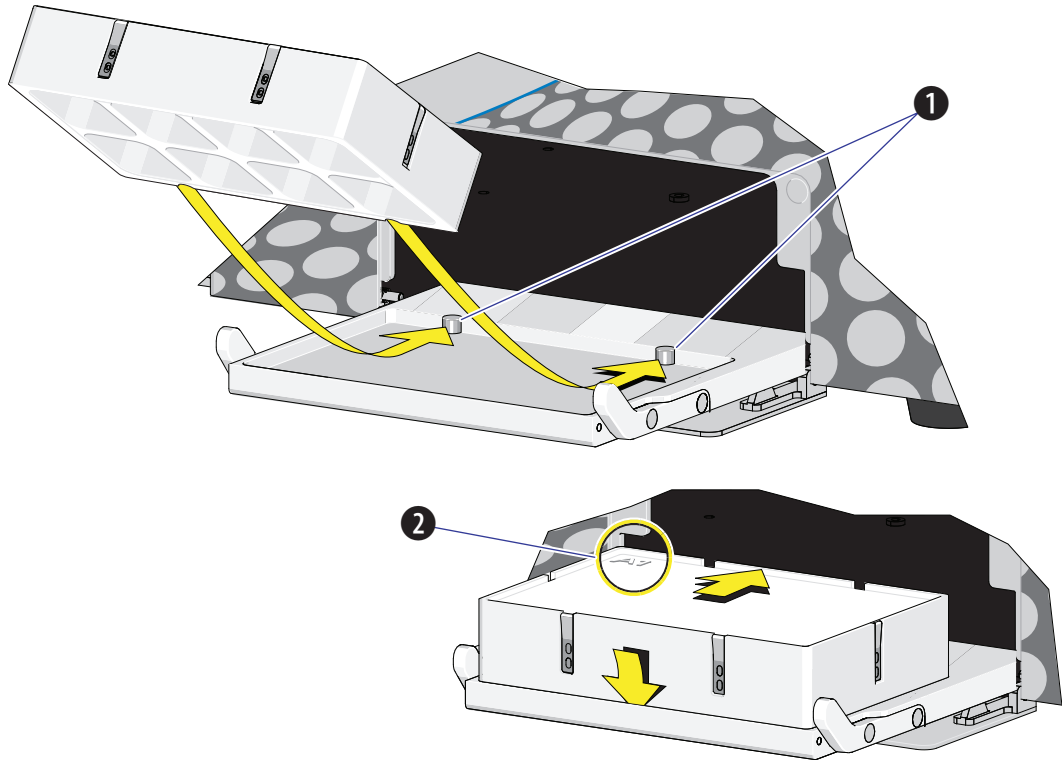
---

**3** Run Daily Clean to clean the sample line. Refer to [CHAPTER 11, Daily Clean](#).

---

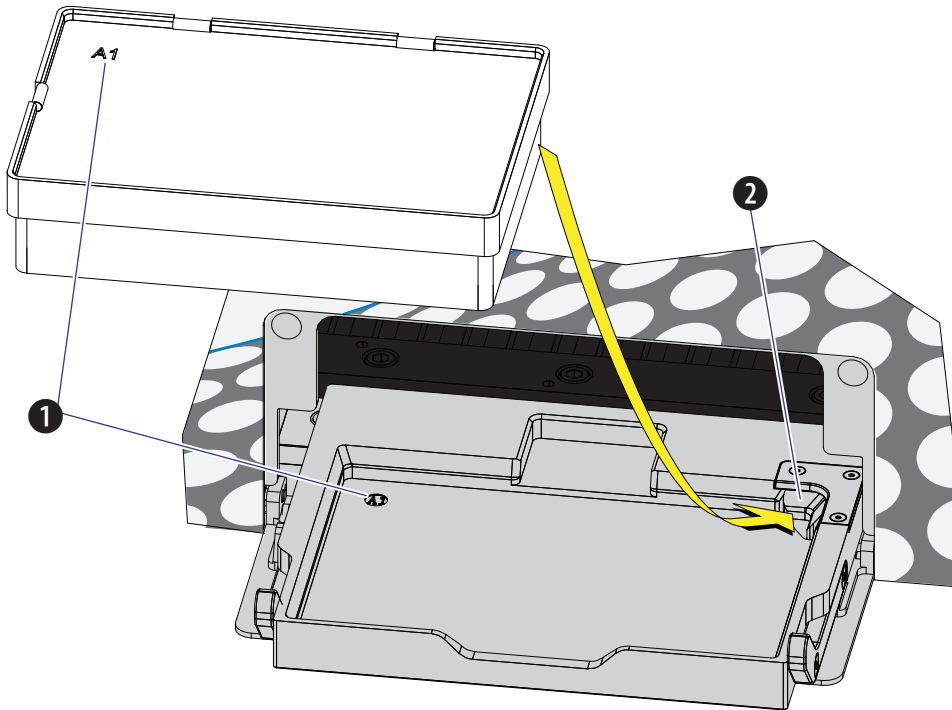
## Replacing the Plate Holder [With Plate Loader]

Figure 12.1 Plate Holder Stage (Standard Plate Loader)



1. Pins
2. Position A1

Figure 12.2 Plate Holder Stage (Plate Loader DW)



1. Position A1
2. Spring lock

**CAUTION**

The plate holder must be secured tightly to the plate holder stage with position A1 located in the top, left corner of the plate holder stage (refer to [Figure 12.1](#) and [Figure 12.2](#)) to prevent instrument damage.

Slide the notches on the bottom of the plate holder (refer to [Figure 1.17](#)) over the pins (refer to [Figure 12.1](#) and [Figure 12.2](#)).

## Plate Loader Module Removal and Reinstallation [With Plate Loader]



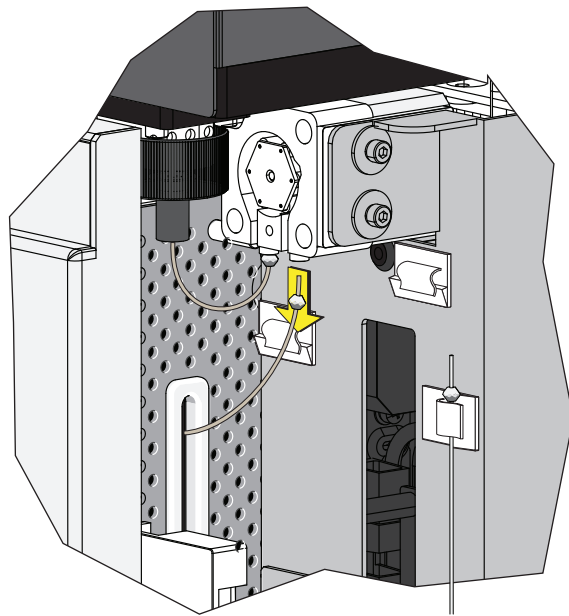
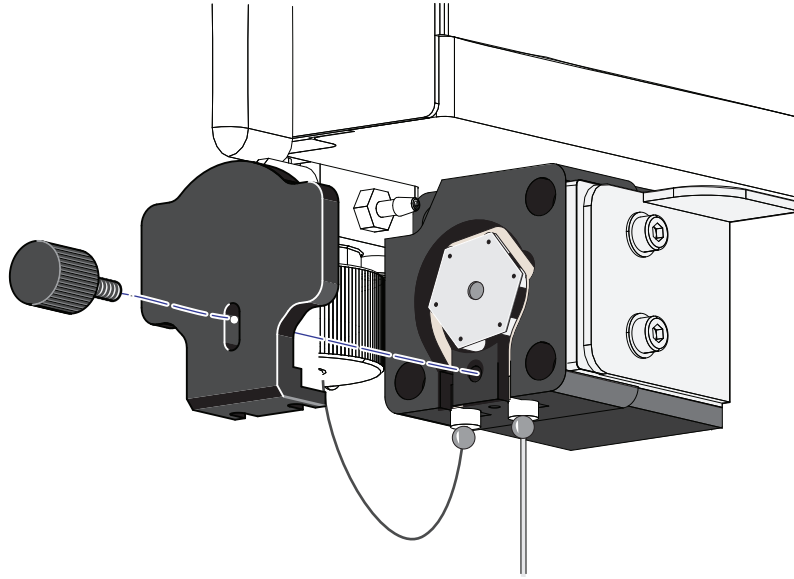
### **WARNING**

**Risk of contamination from biohazardous material. Always wear PPE when performing this procedure as you can contact components with blood residue.**

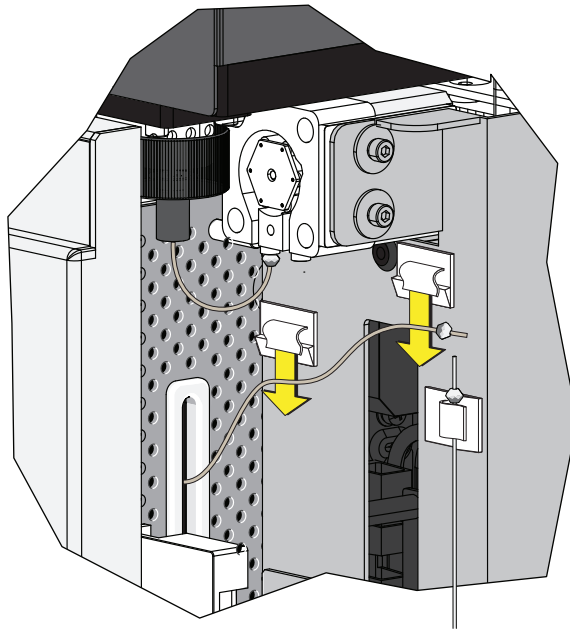
### Removal

- 1 Power down the instrument and disconnect the power cable from the wall.
- 2 Lift the top cover and remove the front cover. Refer to [Front Cover Removal and Reinstallation](#).
- 3 Place absorbent material on the stage in the Plate Loader module.

- 4 In the Sample Station, disconnect that end of the plate loader PEEK tubing.
- If the plate loader PEEK tubing is attached to the sample peristaltic pump tubing, remove the sample pump cover and disconnect the plate loader PEEK tubing.



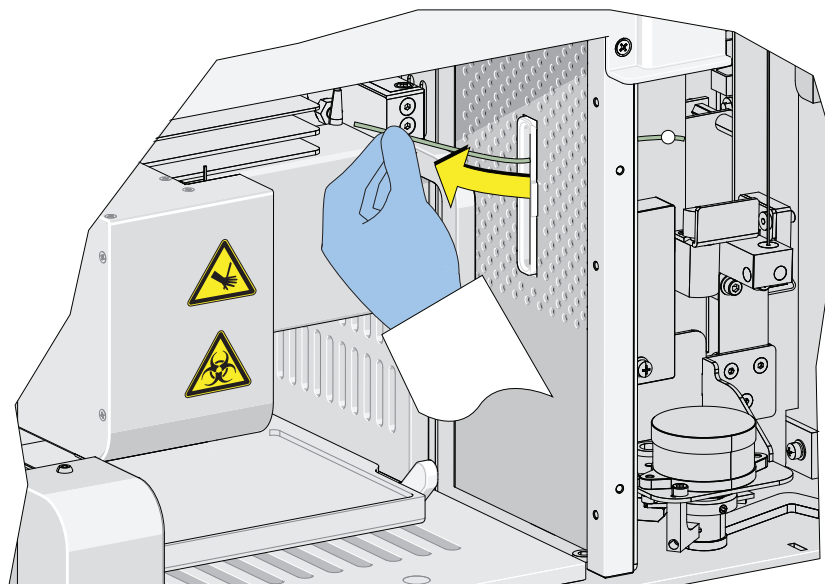
- If the plate loader PEEK tubing is in the plate loader PEEK tubing clips, remove the tubing from the clips.



**⚠ CAUTION**

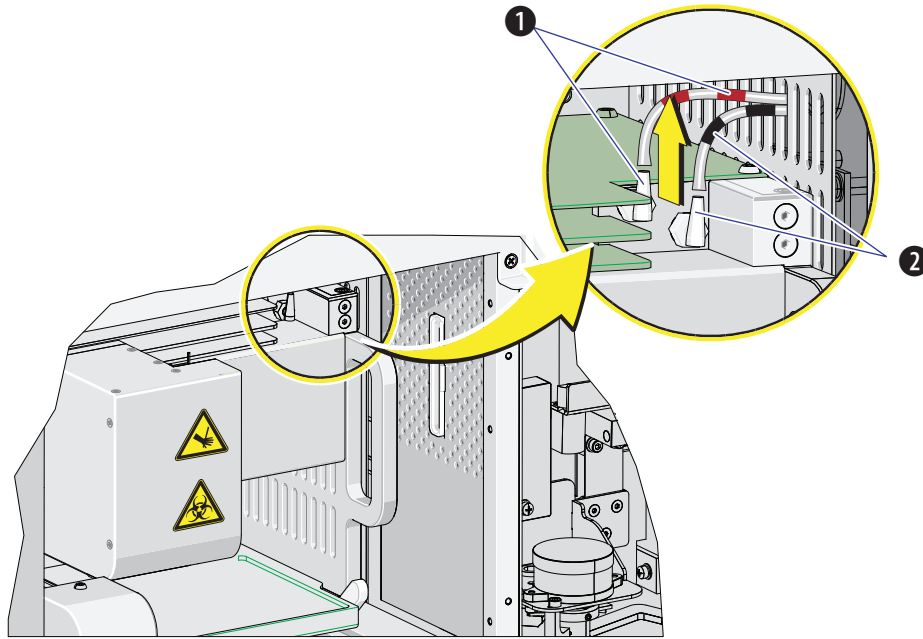
The PEEK tubing can be deformed which could affect sample flow. When routing the Plate Loader PEEK tubing to and from the Sampling Station, be careful not to pinch, crimp, stretch, or break the tubing.

- 5 Pull the plate loader PEEK tubing through the slot so the tubing sits inside the instrument.



- 6 Remove the red and black marked tubes that are attached to the left and right connectors in the Plate Loader module, respectively, as shown in [Figure 12.3](#).

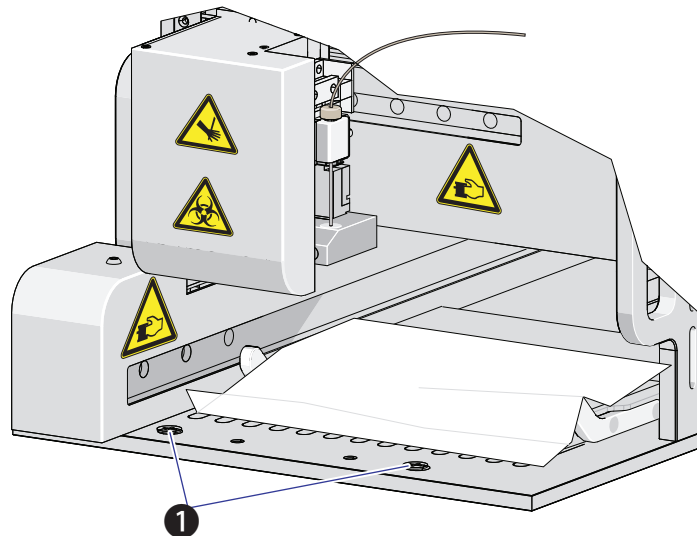
**Figure 12.3** Removing the Tubings from the Fluidics Module to the Plate Loader



1. Red
2. Black

- 7 Remove the two countersunk M4 x 10 Phillips-head screws in the Plate Loader module. Refer to [Figure 12.4](#).

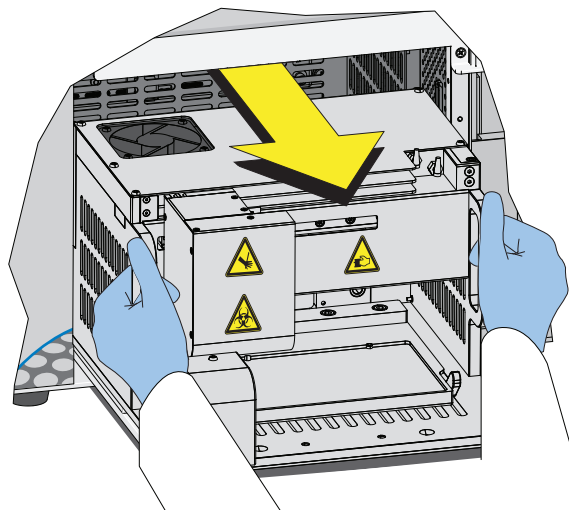
**Figure 12.4** Plate Loader Module Securing Screws



1. Securing screws

- 8 Slide the Plate Loader module out of the Cytometer. Refer to [Figure 12.5](#).

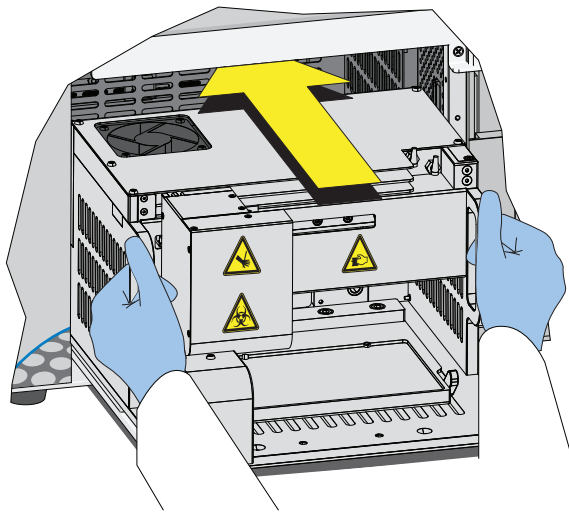
**Figure 12.5** Removing the Plate Loader from the Cytometer



## Installation

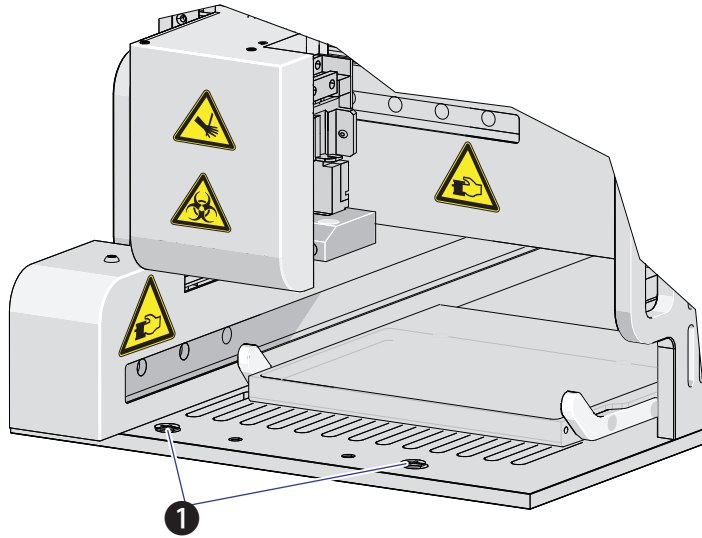
- 1 Remove the front cover. Refer to [Front Cover Removal and Reinstallation](#).
- 2 Remove the right-side cover. Refer to [Right-Side Cover Removal and Reinstallation](#).
- 3 Slide the Plate Loader module into the Cytometer. Refer to [Figure 12.6](#).

**Figure 12.6** Installing the Plate Loader into the Cytometer



- 4 Install the two countersunk M4 x 10 Phillips-head screws in the Plate Loader module. Refer to [Figure 12.7](#).

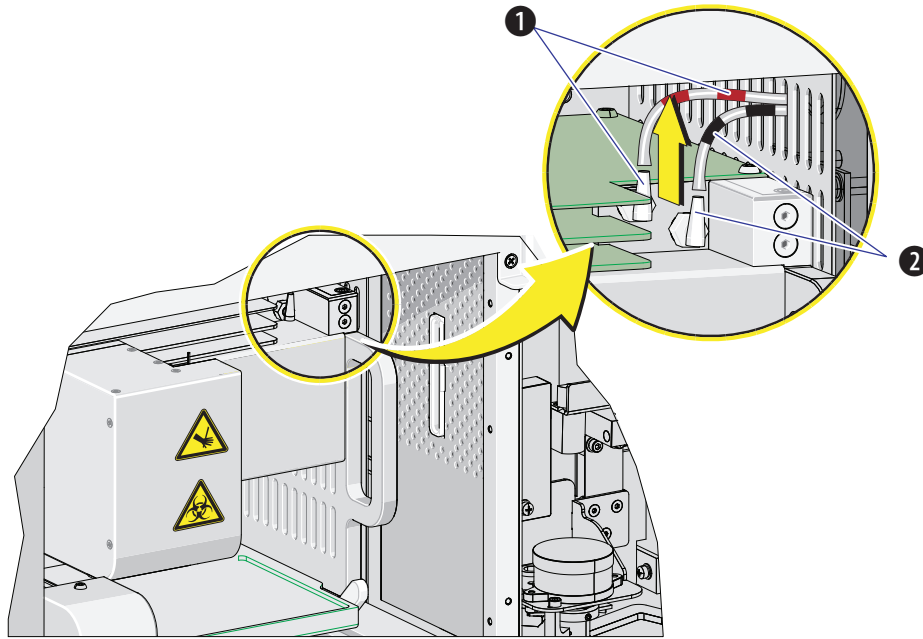
**Figure 12.7** Plate Loader Module Securing Screws



1. Securing screws

- 5 Install the red and black marked tubings that are attached to the left and right connectors in the Plate Loader module, respectively, as shown in [Figure 12.8](#).

**Figure 12.8** Connecting the Tubings from the Fluidics Module to the Plate Loader

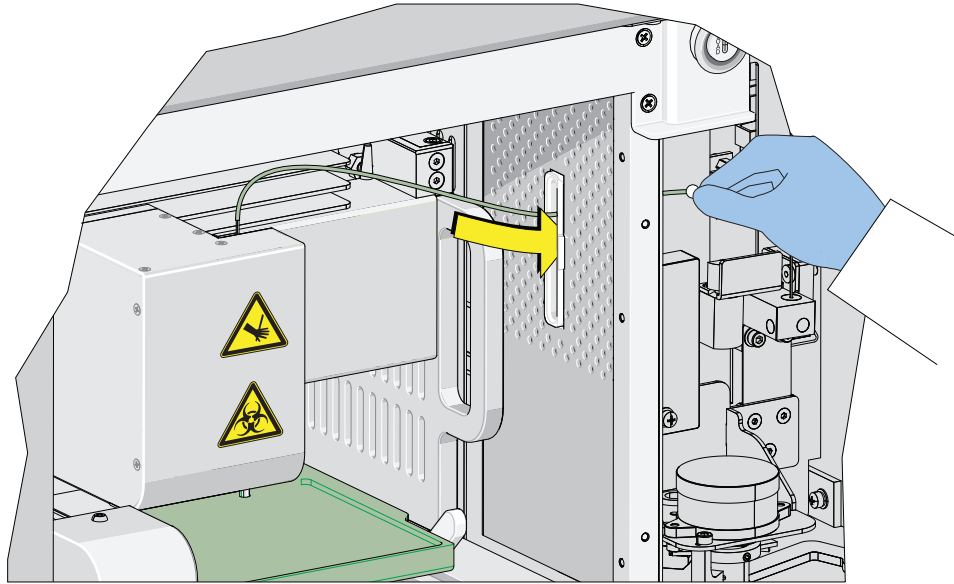


1. Red
2. Black

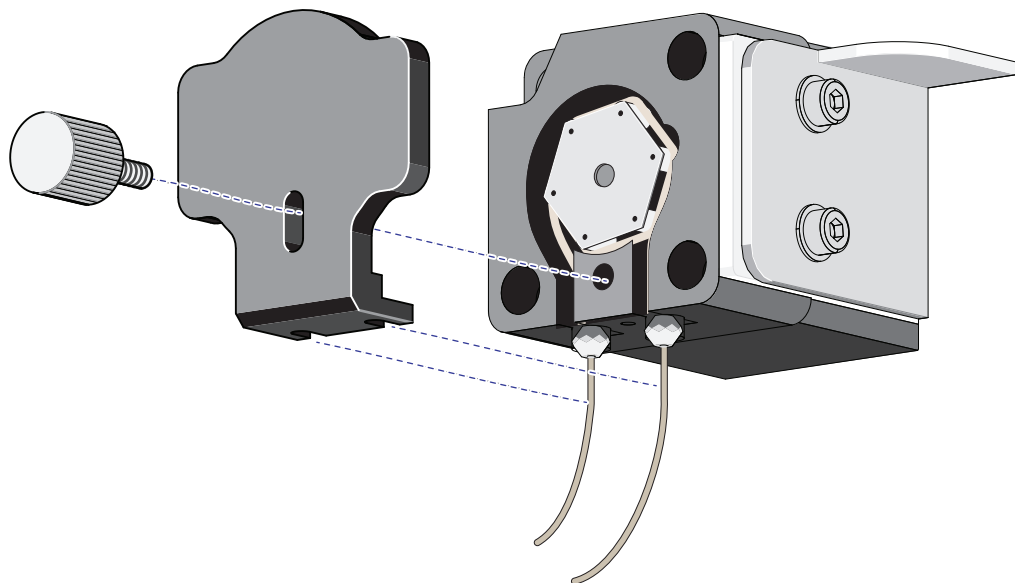
**⚠ CAUTION**

The PEEK tubing can be deformed, which could affect sample flow. When routing the Plate Loader PEEK tubing to and from the Sampling Station, be careful not to pinch, crimp, stretch, or break the tubing.

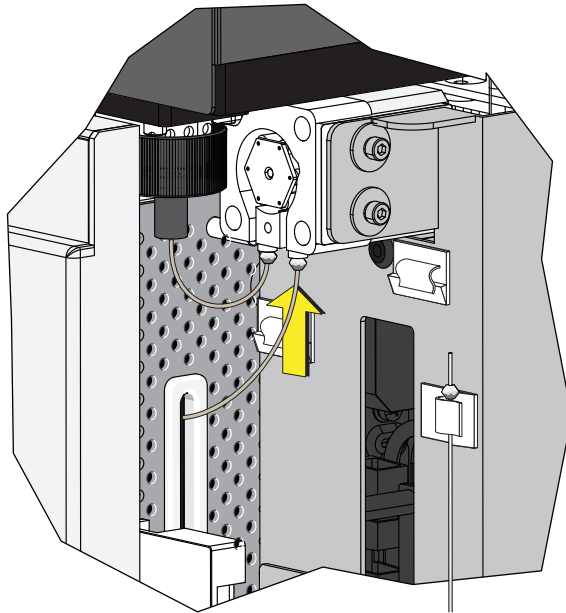
- 6 Slide the new plate loader PEEK tubing through the slot into the single tube sample station area.



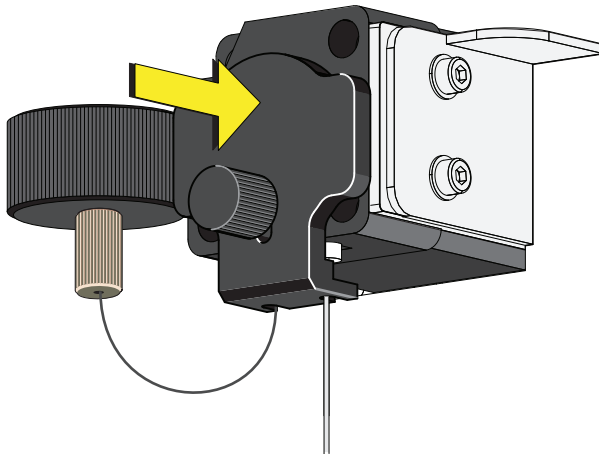
- 7 Remove the sample pump cover thumbscrew and the sample pump cover.



- 
- 8 Connect the plate loader PEEK tubing to the sample peristaltic pump tubing.



- 
- 9 Reinstall the sample pump cover.



**NOTE** To ensure the proper placement of the sample probe, push the sample pump cover up while installing the thumbscrew.

- 
- 10 Replace the right-side cover (refer to [CHAPTER 12, Right-Side Cover Removal and Reinstallation](#)), and lock with the screw.

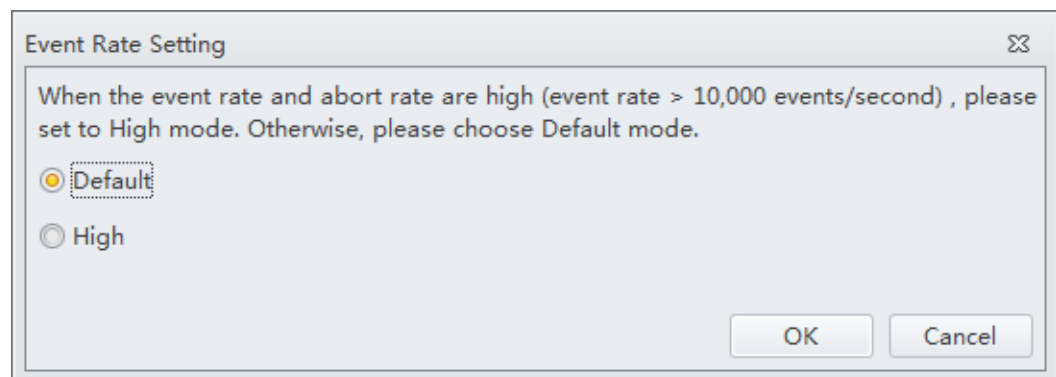
- 
- 11 Replace the front cover. Refer to [Front Cover Removal and Reinstallation](#).

- 12 Close the top cover.
- 13 Turn the Cytometer's main power switch on.
- 14 Verify that the system is operating correctly by running QC in the Plate Loader mode. Refer to [CHAPTER 5, Preparing the QC Sample \[With Plate Loader\]](#) and [CHAPTER 5, Collecting QC Data \[With Plate Loader\]](#).

## Changing the Event Rate Setting

The Event Rate Setting adjusts the collection setting around signal measurement so that the system is able to optimize the acquisition of events ensuring optimal sensitivity and abort rates when acquiring at higher event rates.

- 1 Select **Event Rate Setting** in the Advanced menu. The Event Rate Setting window appears.



- 2 Select **High** if the event rate is >10,000 events/second.  
Or  
Select **Default** if the event rate is <10,000 events/second.
- 3 Select **OK**.

## Nonscheduled Replacement/Adjustment

---

### Calibrating the Sample Flow Rate

Calibrate the sample flow rate:

- After replacing the sample peristaltic pump tubing.
- If a precise volumetric measurement is required.  
The accuracy of concentration calculations can be affected by the sample flow rate.

- 
- 1 Verify that the instrument is in the initialized state.
- 
- 2 Select **Calibrate Sample Flow Rate** in the Cytometer menu.

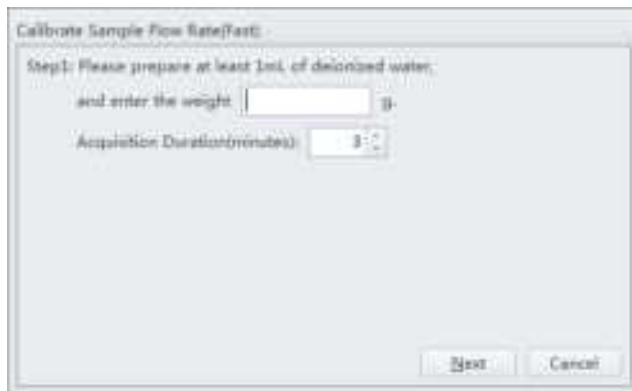


**3** Select the flow rate to be calibrated.

If you want to calibrate all flow rates at once, fast calibration is recommended. The rate selected in the Calibrate Sample Flow Rate window overrides the rate selected in the Acquisition window.



**4** Prepare one sample tube with 1 mL of clean deionized water then use a calibrated analytical balance to measure the weight of the prepared sample tube. Record the weight and enter it into the software.



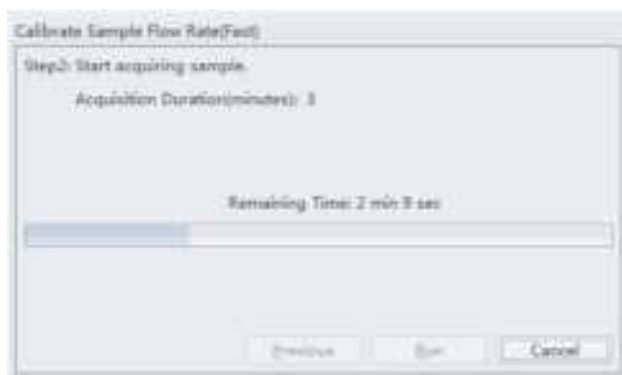
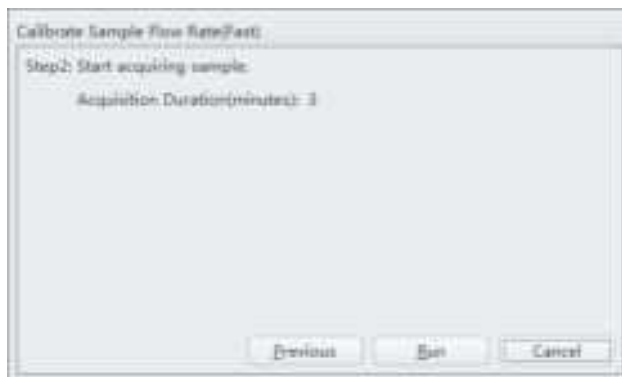
**NOTE** The weight section accepts up to four decimal places.

**5** Select **Next** and put the sample tube in the sample loading position (see [Figure 1.12](#)).

- 6 Select **Initialize** to start the sample run.



- 7 Select **Run** to begin acquiring the sample.



- 8 Wait for the sample run to finish, remove the sample tube, and use the analytical balance to measure the weight and record the value.



- 9 Select **Next** to determine if the results fall within the acceptable range.  
**If the results fall within the acceptable range, the current setting is kept.**



If deviation occurs, the setting is automatically corrected.



## Calibrating the Sample Flow Rate [With Plate Loader]

Calibrate the sample flow rate:

- After replacing the sample peristaltic pump tubing.
- If a precise volumetric measurement is required.

The accuracy of concentration calculations can be affected by the sample flow rate.

---

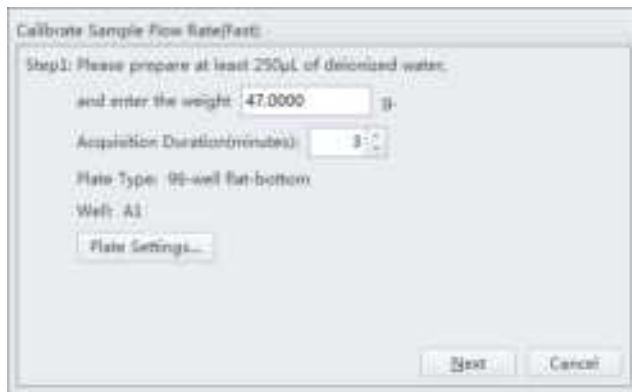
1 Verify that the instrument is in the initialized state.

---

2 Select **Calibrate Sample Flow Rate** in the Cytometer menu. The plate loader automatically ejects the plate holder stage.



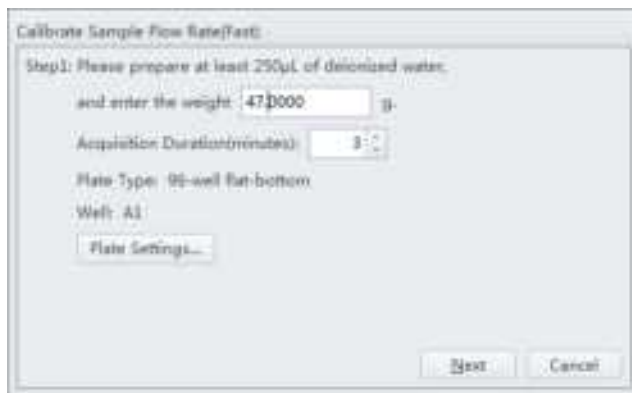
- 3 Select the sampling speed that needs to be calibrated and select **Calibrate**. The Calibrate Sample Flow Rate window appears.



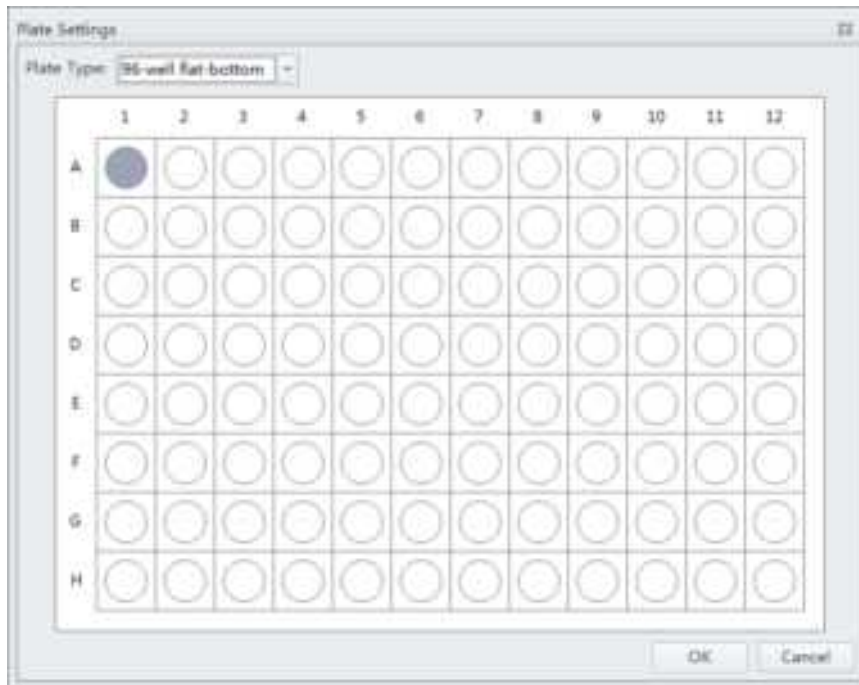
- 4 Follow the on-screen software prompts, then weigh the sample plate.

- 5 Enter the weight of the sample plate and set the acquisition time.

**NOTE** Do not exceed three minutes when using the fast sampling rate.



- 6 Select **Plate Settings** to set the sample well and plate type.



- 7 Select **OK** to save the settings.

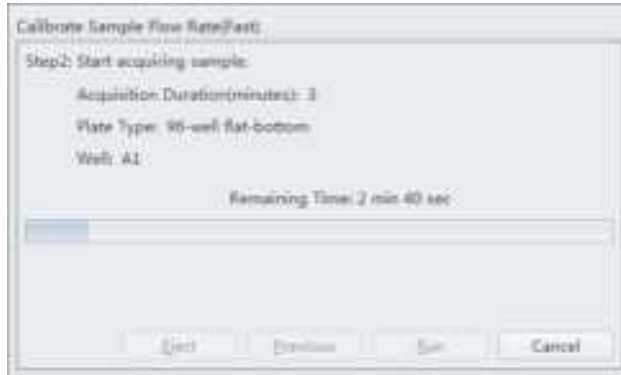
- 8 Select **Next** to proceed to the next step. The plate loader automatically ejects the plate holder stage.



- 9 Place the sample plate onto the plate loader.

- 10 Verify the settings and select **Load** to load the plate.

- 11** Select **Run**. The message *Please confirm that the correct plate is placed properly and press OK* appears. Select **OK**. The system begins acquiring the sample.



- 12** The plate loader automatically ejects the plate holder stage after the sample is acquired. Weigh the plate.

- 13** Enter the remaining weight value and select **Next** to confirm the calibration.

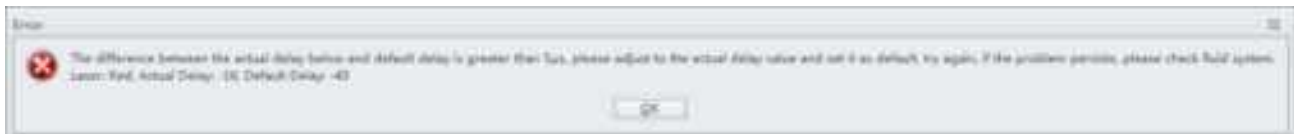


14 Select **OK**.

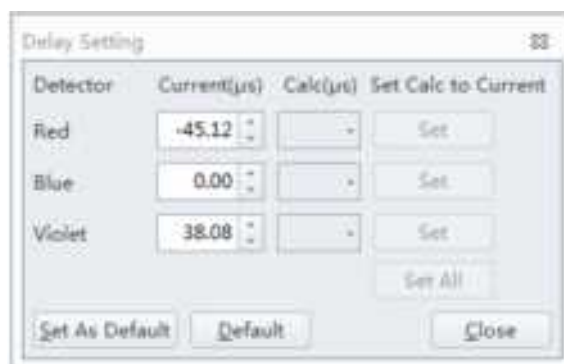


## Setting Laser Delay

Laser delay is preset for QC. Only change the laser delay if the software prompts you that there is a difference in the actual delay and the default delay.



1 Select **Delay Setting** from the Advanced menu. The Delay Setting window appears.



2 Set the current to the actual delay for the specified detector stated in the error message received.

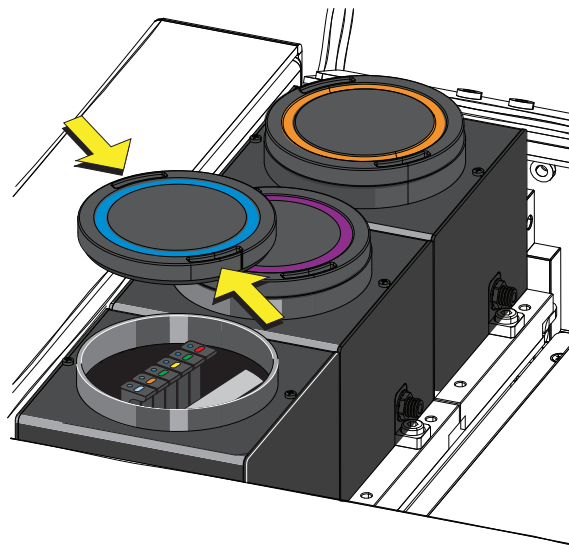
3 Select **Set as Default**.

- 
- 4 Select **Close**.
- 

## Replacing the Optical Filter

When the optical filter is damaged or it is required to use an optical filter with a non-standard wavelength, you must replace the optical filter yourself. For the specific part number of the optical filter, consult your Beckman Coulter Representative or your local dealer.

- 
- 1 Confirm that the instrument is in the standby state or that the instrument is turned off.
  - 2 Confirm the laser corresponds to the channel in which the optical filter is to be replaced.
  - 3 Open the top cover of the instrument.
- 
- 4 Press the spring piece of the WDM cap corresponding to the laser, and open the WDM cap.
- 



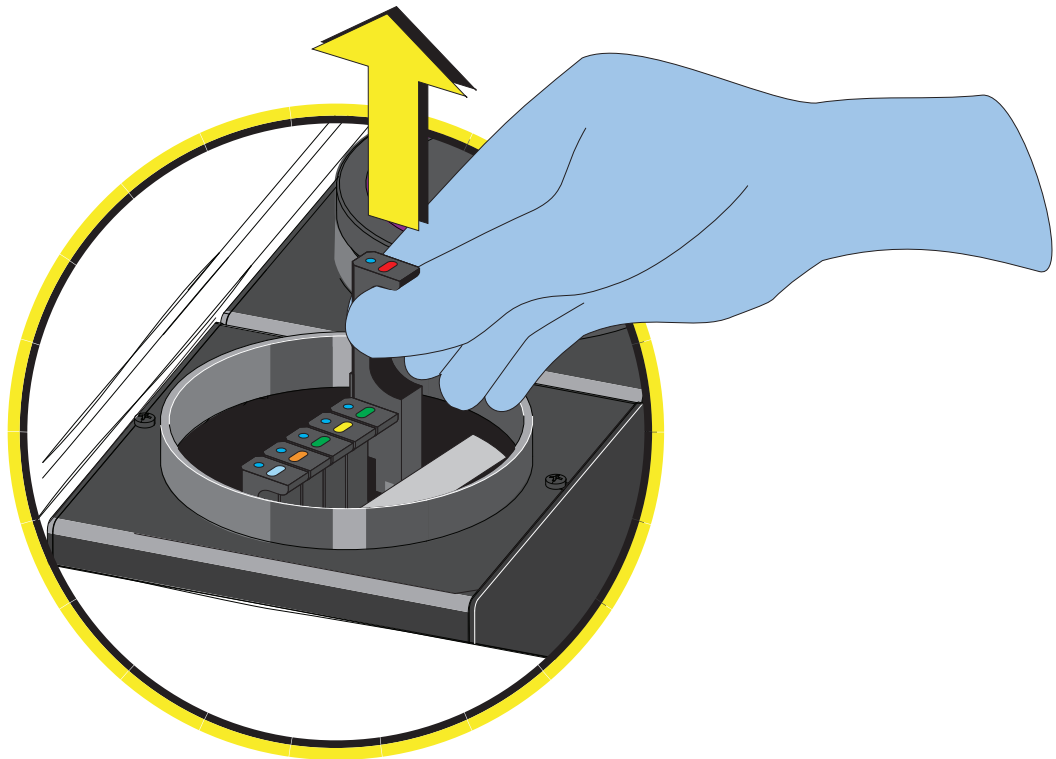
**CAUTION**

Risk of damage to the optical filter. Do not touch the optical filter glass piece. Touching the optical filter glass piece can obscure and/or scratch the optical filter glass piece.

**CAUTION**

Risk of damage to the optical filter. Pull the filter straight up when removing it from the WDM. Removing the filter at an angle could chip the edge of the filter glass.

- 5 Use vertical force to remove the optical filter to be replaced, and note the color identification and wavelength identification on the optical filter bracket.



 **CAUTION**

**Risk of damage to the optical filter. Push the filter straight down when inserting it into the WDM. Inserting the filter at an angle could chip the edge of the filter glass.**

**IMPORTANT** Stop applying downward force as soon as you feel a click. This indicates that the ball-lock is seated correctly and that the filter is in the correct position. Continuing to apply downward pressure may damage the filter.

**6** Insert the optical filter to be installed vertically into the corresponding position, taking care to align the wavelength identification with the left, and that the bracket is inserted into the bottom.

**7** Close the WDM cap and the instrument top cover.

**8** Turn on the Cytometer and open the software.

**9** Select **Detector Configuration** in the Cytometer menu and create a new instrument configuration based on the settings of the new optical filter. Refer to [CHAPTER 6, Verifying, Selecting, Editing, and Creating Detector Configuration](#). Set this new configuration as the current configuration.

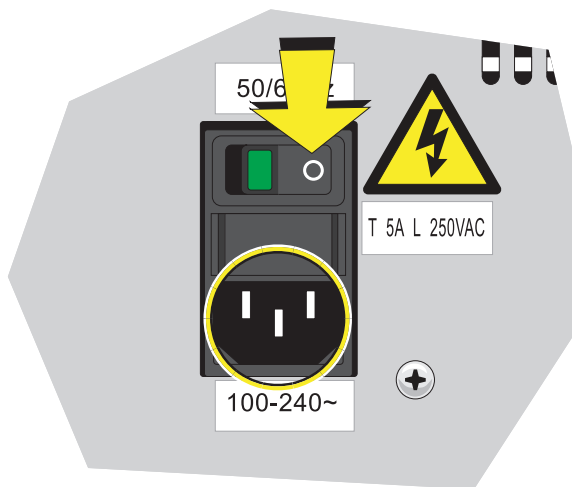
## Replacing the Fuse

Use a 5 A, time delay, T 5 AL, 250 VAC fuse.

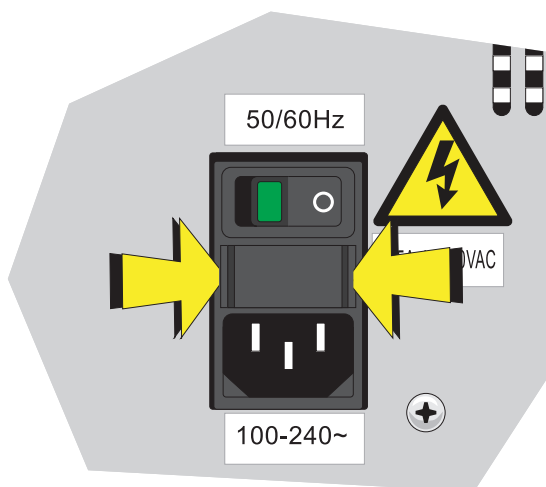
**⚠ WARNING**

**Risk of personal injury. A shock hazard exists if the power cable is connected. Turn off the Cytometer and disconnect the primary power cable before performing these procedures.**

- 1 Turn off the Cytometer, and disconnect the power cable.



- 2 Press both sides of the fuse holder of the instrument inwards using a flat head screwdriver, and pull out the fuse holder.



---

**IMPORTANT** Select well-performing products that comply with the specifications required, to ensure that the instrument can function normally and safely.

- 3 Check whether the fuse installed is blown, and replace the blown fuse with a new one.

The specifications of the fuse required are: T 5 AL 250 VAC, delay blow fuse, 5A, 250 VAC, 5 x 20 mm. Beckman Coulter recommends using SCHURTER 0034.3124.



- 
- 4 Insert the fuse holder.

- 
- 5 Reconnect the power cable.
- 

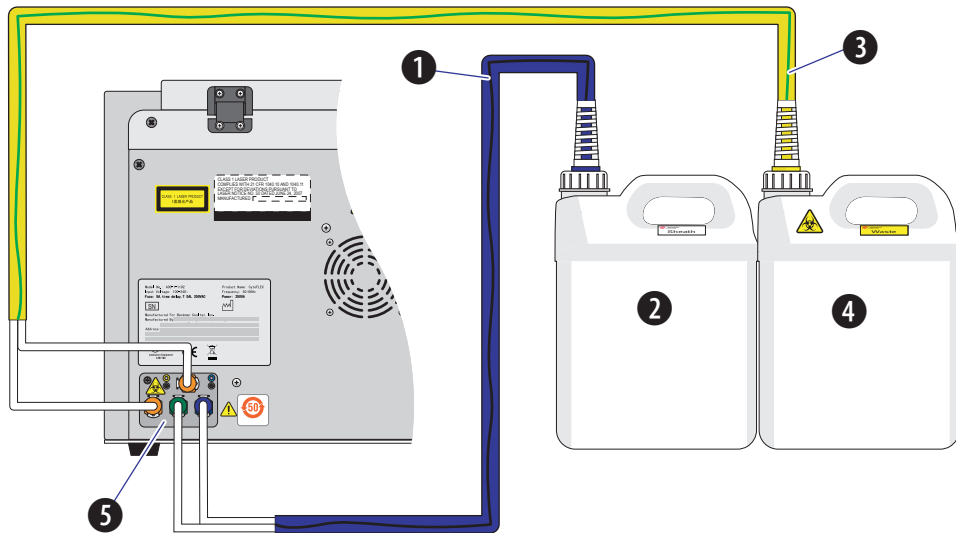
## Replacing the Sheath Fluid Harness and/or Waste Harness

Replace the sheath fluid harness and/or the waste harness if you have a faulty sheath fluid sensor and/or waste sensor.

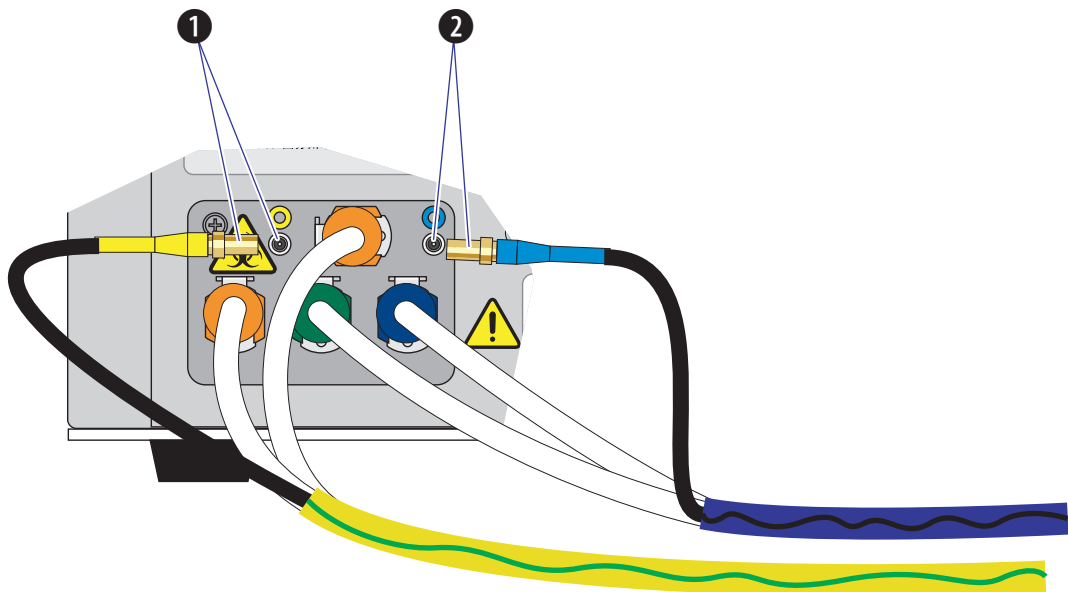
- 
- 1 Confirm that the instrument is turned off or is in the standby state.

- 
- 2 Remove sheath and/or waste pickup tubing from the appropriate container.

- 3 Disconnect the blue harness (1) from the sheath fluid container (2) and/or the yellow harness (3) from the waste container (4) from the fluid connector panel (5) on the back right corner of the instrument according to the color code.

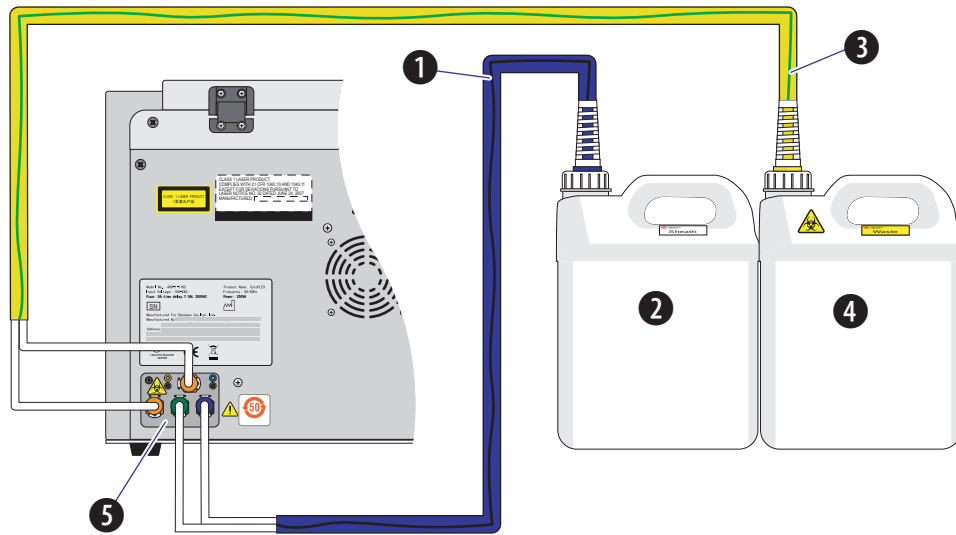


Disconnect the waste (1) and/or sheath (2) level sensors.

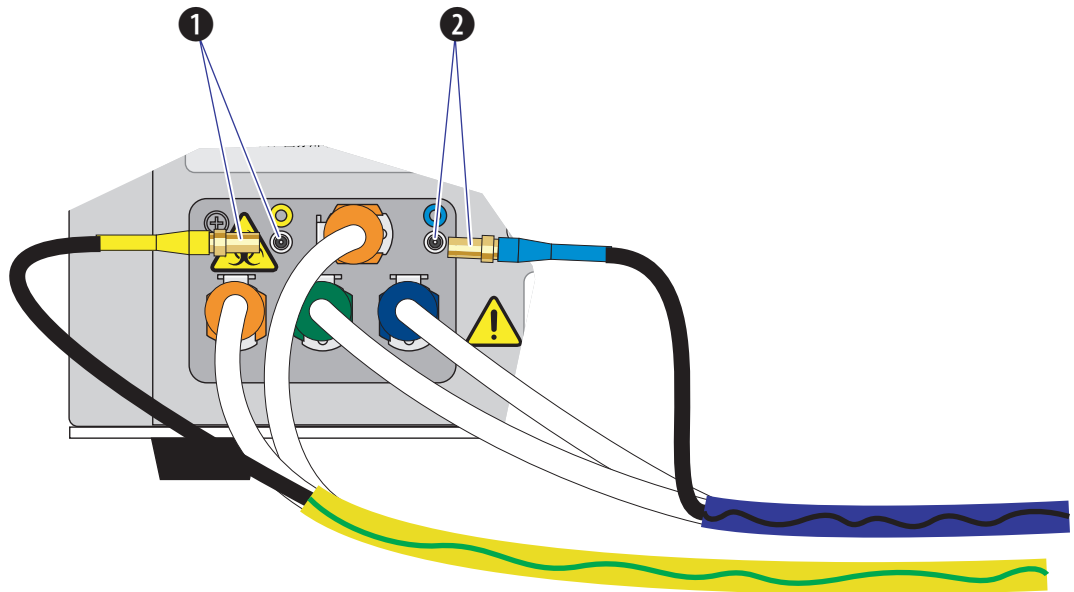


- 4 Dispose of the sheath fluid harness and/or the waste harness according to your laboratory procedures.
- 5 Insert the new sheath and/or waste pickup tubing into the appropriate container.

- 6 Connect the blue harness (1) from the sheath fluid container (2) and/or the yellow harness (3) from the waste container (4) to the fluid connector panel (5) on the back right corner of the instrument according to the color code.



Connect the waste (1) and/or sheath (2) level sensors.



## Changing Sample Mixing and Backflush Settings



### WARNING

**Risk of biohazardous contamination. Enabling sample mixing for 1.5 mL and 2 mL sample tubes in the semi-automatic sample injection mode can result in sample splashing. Exceeding 300  $\mu$ L sample volume when using 1.5 mL and/or 2 mL sample tubes can also result in sample splashing. Disable sample mixing in the semi-automatic sample injection mode when using 1.5 mL and 2 mL sample tubes and do not exceed 300  $\mu$ L sample volume.**

The sample mixer can be enabled or disabled if necessary. The sample mixing duration can also be increased or decreased if necessary.

Whenever a sample is likely to leave residue or cause contamination, the backflush time can be increased to reduce cross contamination.

- 1 Open the CytExpert software and confirm that the instrument is connected. Refer to [CHAPTER 4, Logging into the Software](#).
- 2 Select **Cytometer Configuration** in the Cytometer menu. The Cytometer Configuration window appears.



---

**3** Select the Sample Mixing checkbox to enable sample mixing.

Or

Deselect the Sample Mixing checkbox to disable sample mixing.

---

**4** Change the sample mixing duration to the desired time.

**NOTE** The default setting is 1 second. Select **Default** to set the Cytometer configuration settings back to the factory default settings.

---

**5** Change the backflush duration to the desired time for either the Manual/Semi-Automatic sample injection mode or the Plate Loader sample injection mode depending on the current sample injection mode selected.

**NOTE** The default setting is 3 seconds without the Sample Injection Mode Control Kit installed or 4 seconds [**CytoFLEX and CytoFLEX S**] or 6 seconds [**CytoFLEX LX**] with the Sample Injection Mode Control Kit installed. For [**CytoFLEX and/or CytoFLEX S**] with Sample Injection Mode Control Kit, perform an additional 6 second backflush or alternatively running daily clean after running QC.

---

**6** Select **OK**.

---

## Calibrating the Plate Position [With Plate Loader]

Use the following procedure to calibrate the plate position and the sample probe position:

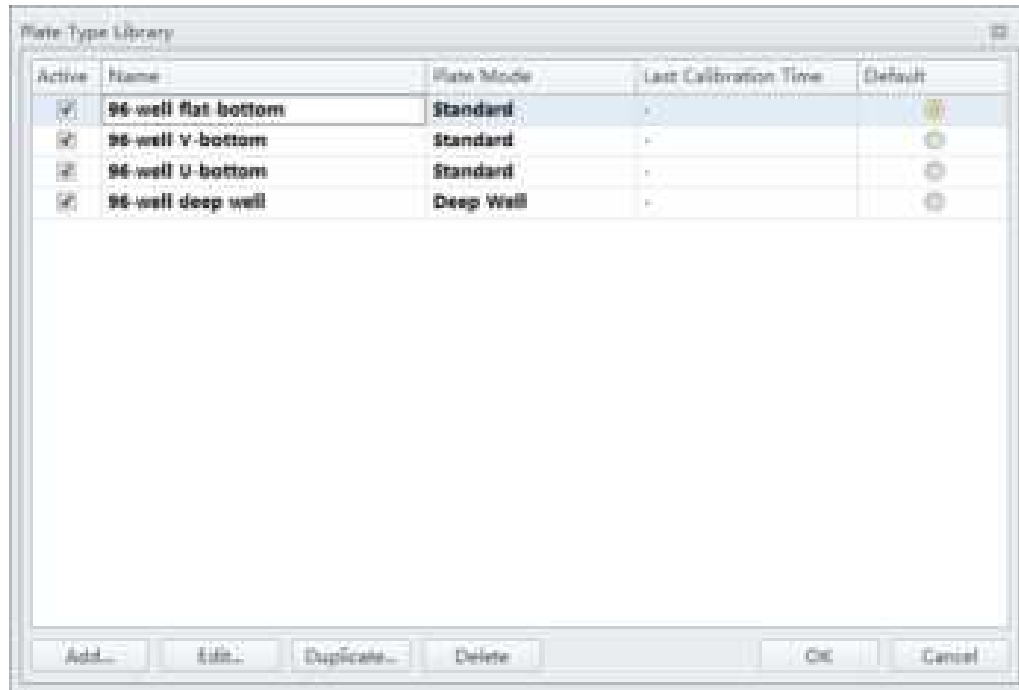
- Upon installation
  - After a new plate type is defined for first use
  - After changing plate manufacturers of the same previously calibrated plate type
  - When optimizing plate performance
- 

**1** Remove the front cover. Refer to [CHAPTER 12, Front Cover Removal and Reinstallation](#).

---

**2** Select  .

- 3 Select **Plate Type Library** in the Advanced menu. The plate loader automatically ejects the plate holder stage and the Plate Type Library window appears.



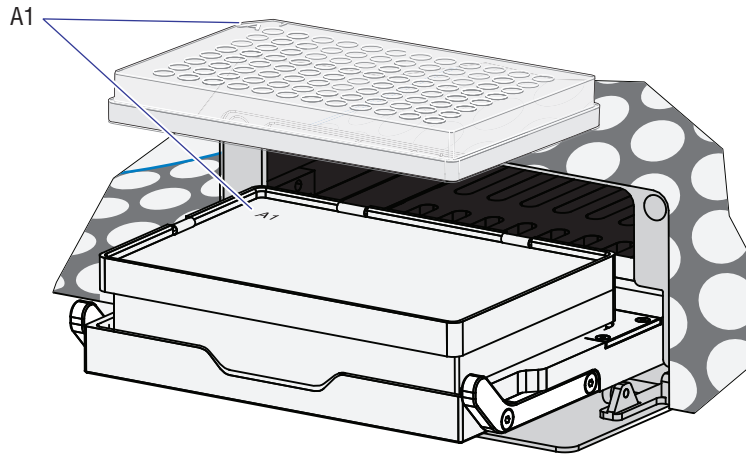
**NOTE** The 96-well deep well plate is only available for use if the Plate Loader DW is installed.

**[Standard 96-Well Plate]:** Proceed to Step 4.

**[96-Well Deep Well Plate]:** Skip to Step 5.

- 4** [Standard 96-Well Plate]: Select the plate type and place the plate on the plate holder. Skip to Step 11.

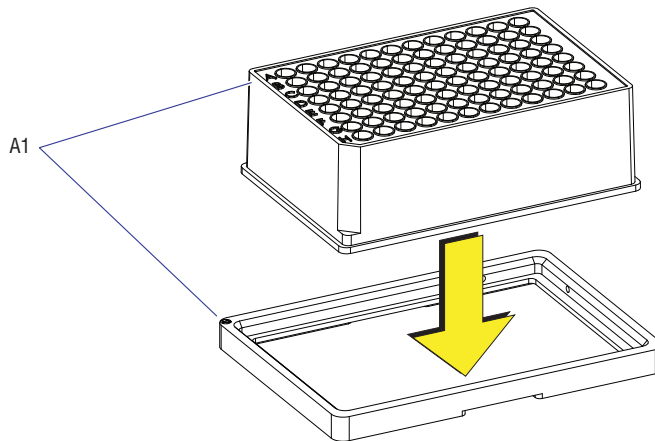
**[Standard 96-Well Plate in the Plate Holder (Plate Loader DW -With groove)]**



**NOTE** Ensure plate well A1 aligns with position A1.

- 5** [96-Well Deep Well Plate]: Select the 96-Well Deep Well plate type.

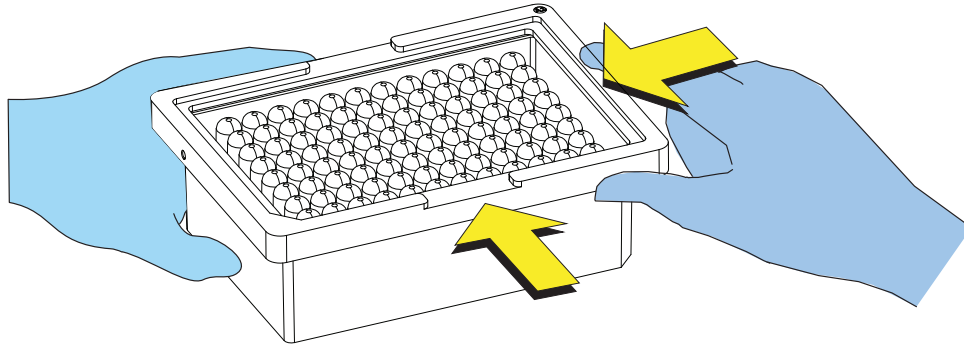
- 6** [96-Well Deep Well Plate]: Place a 96-well deep well plate into the calibration frame.



**NOTE** Ensure plate well A1 aligns with position A1.

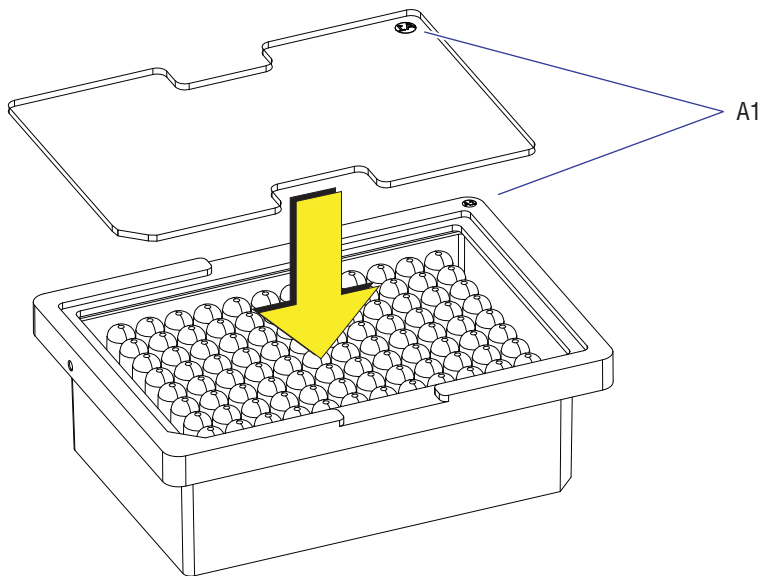
**NOTE** The calibration frame and the transparent plate are used to assist the calibration in X-axis and Y-axis. They are delivered together with the Plate Loader DW.

- 7 [96-Well Deep Well Plate]:** Turn the calibration frame together with the deep well plate upside down. Push the right corner of the frame into place against the lower right corner of the plate.



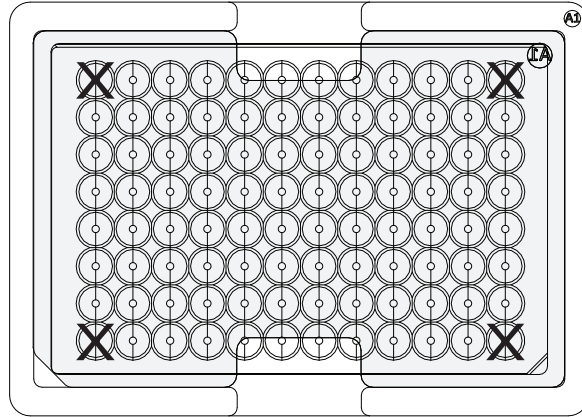
**NOTE** Ensure the deep well plate is correctly placed into the calibration frame.

- 8 [96-Well Deep Well Plate]:** Place the transparent plate on the frame.

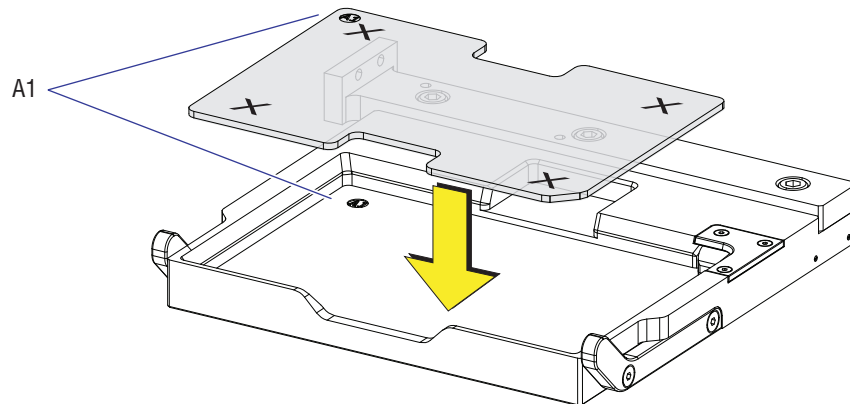


**NOTE** Ensure the A1 of the transparent plate aligns with position well A1.

- 9 [96-Well Deep Well Plate Shown]:** Mark the center position of well A1, A12, H1, H12 on the transparent plate.



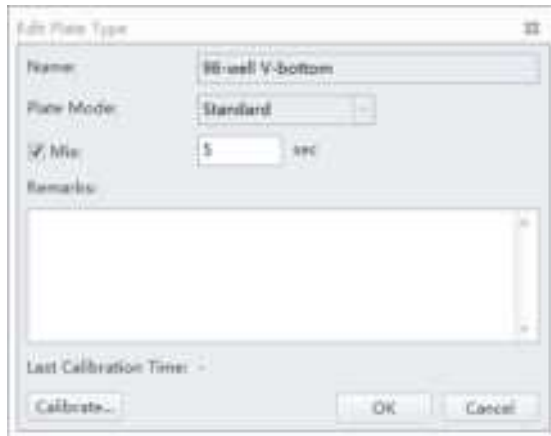
- 10 [96-Well Deep Well Plate]:** Place the transparent plate on the plate holder stage.



**NOTE** Ensure plate well A1 aligns with position A1.

**11** Select **Edit** to access the calibrate icon. The Edit Plate Type window appears.

**[Standard 96-Well Plate]**



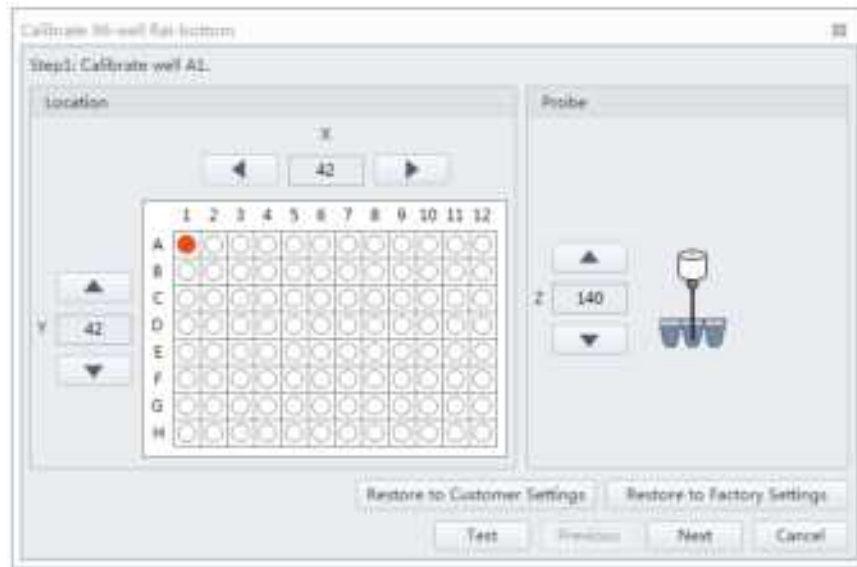
**[96-Well Deep Well Plate]**



**NOTE** You can access the calibrate icon by either adding a plate or duplicating a plate. Refer to [CHAPTER 2, Plate Type Library](#).

**12** Set the Mix settings.

- 13** Select **Calibrate**. The message *Please confirm that the plate is placed properly and Press Ok.* appears. Select **OK**. The plate loader loads the plate holder stage and the sample probe moves to the sample aspiration position of well A1.







[Standard 96-Well Plate]: Proceed to Step 14.

[96-Well Deep Well Plate]: Skip to Step 15.

**CAUTION**

**Risk of instrument damage. Do not crash the probe into the bottom of the plate as this will cause irreparable damage to the probe. Move the probe one step at a time when lowering the probe on the Z-axis toward the bottom of the plate. You will hear a click when the probe makes contact with the bottom of the well, this is the extreme position for the Z-axis of the probe. Do not move the probe any lower after you hear the click.**

- 14** [Standard 96-Well Plate]: Select  and  or  and  to adjust the sample probe positions in the X-, Y-, and Z-axes.





Ensure the sample probe is centered and touches the bottom of the well.

**NOTE** The sample probe should just make contact with the bottom of the well.

**NOTE** The X-axis arrows moves the sample probe well position left and right. The Y-axis arrows moves the sample probe well position forward and back. The Z-axis arrows moves the sample probe up and down.

Skip to Step 16.

---

**15 [96-Well Deep Well Plate]:** Select  and  or  and  to adjust the sample probe positions in the X- and Y-axes.

Ensure the sample probe is centered on the mark of transparent plate.

**NOTE** The X-axis arrows moves the sample probe well position left and right. The Y-axis arrows moves the sample probe well position forward and back. The Z-axis arrows moves the sample probe up and down.

---

**16** Select **Test** to verify the sample probe position.

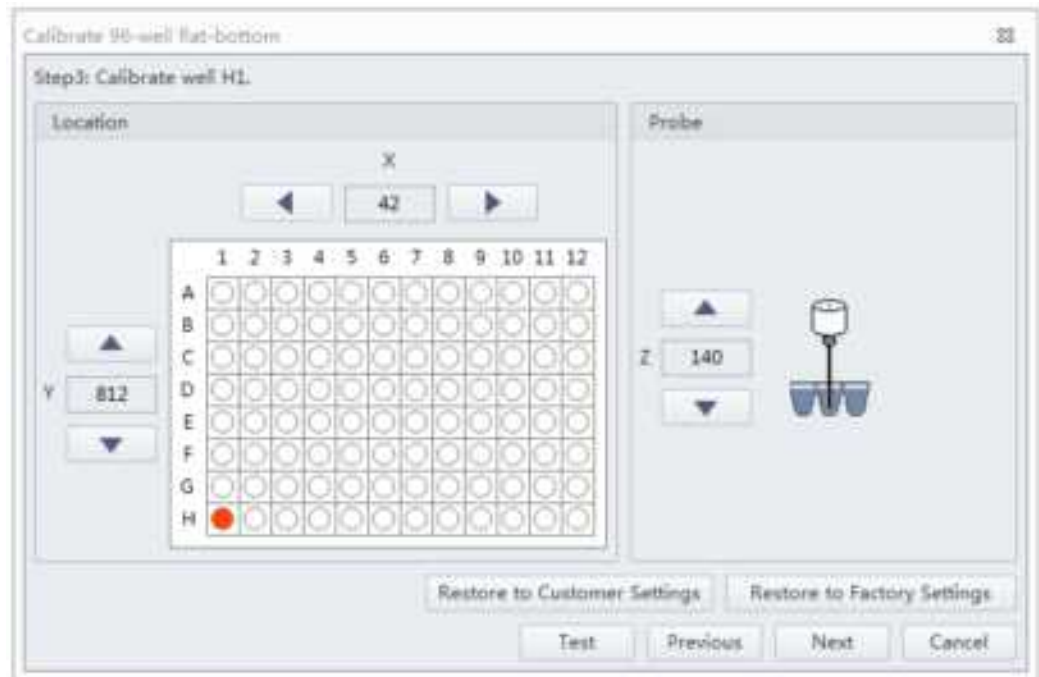
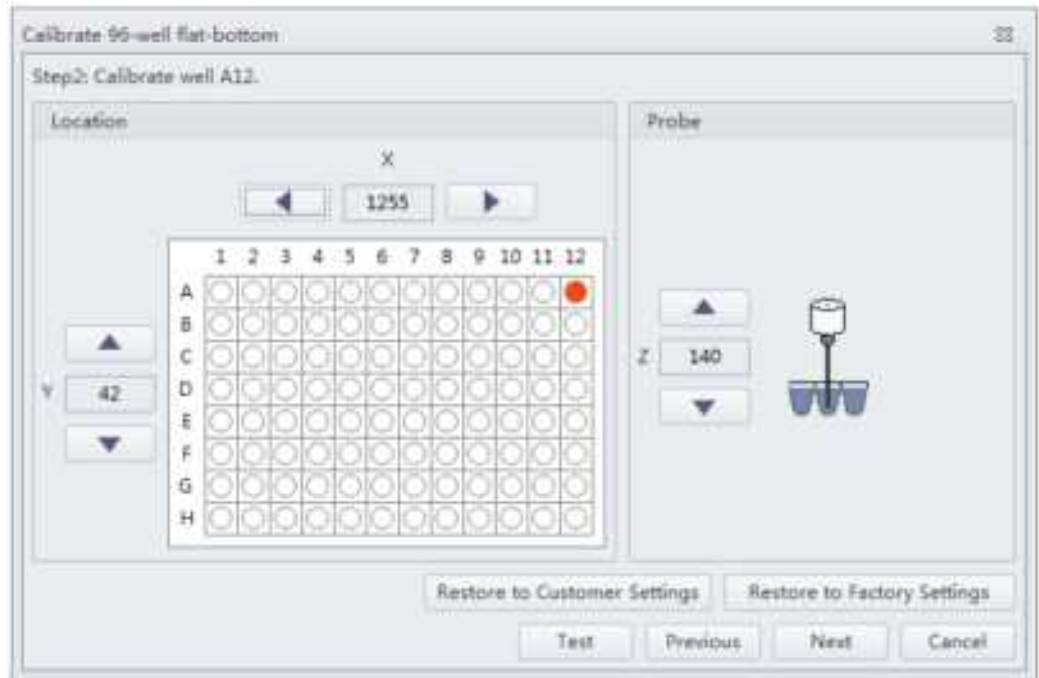
Listen for the click to ensure the probe has made contact with the bottom of the well. Readjust the sample probe position by moving the probe 3 steps up. This is the correct position for the Z-axis of the probe.

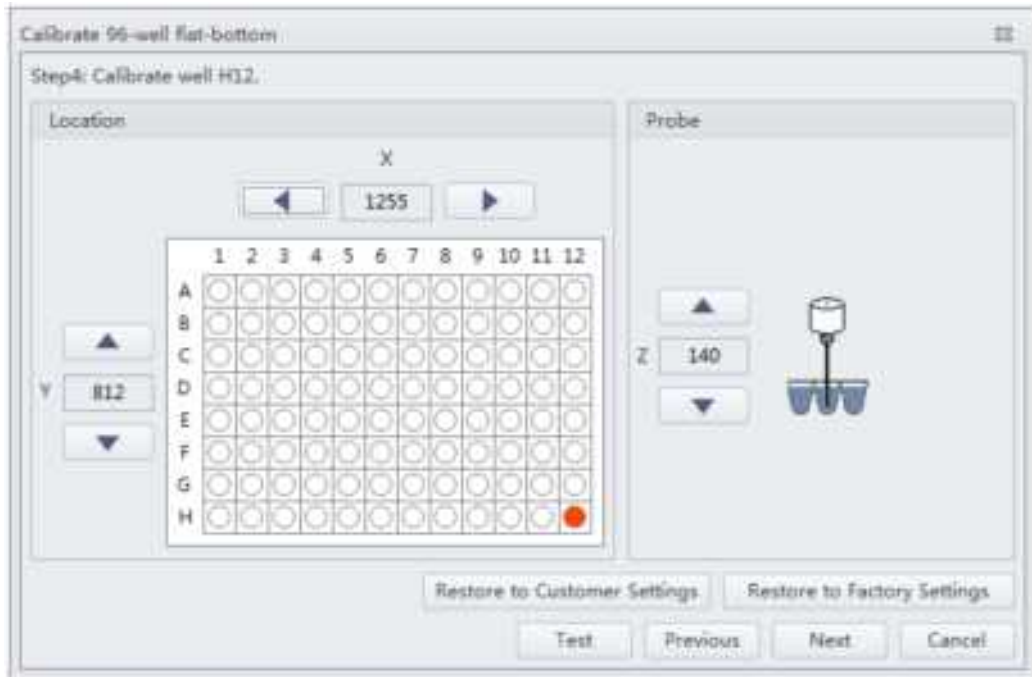
**NOTE [Transparent Plate]:** The sample probe cannot come in contact with the surface of the transparent plate in the Z-axis. This is normal. Do not adjust the sample probe positions in the X-axis. The probe position in the Z-axis will be calibrated using a deep well plate.

---

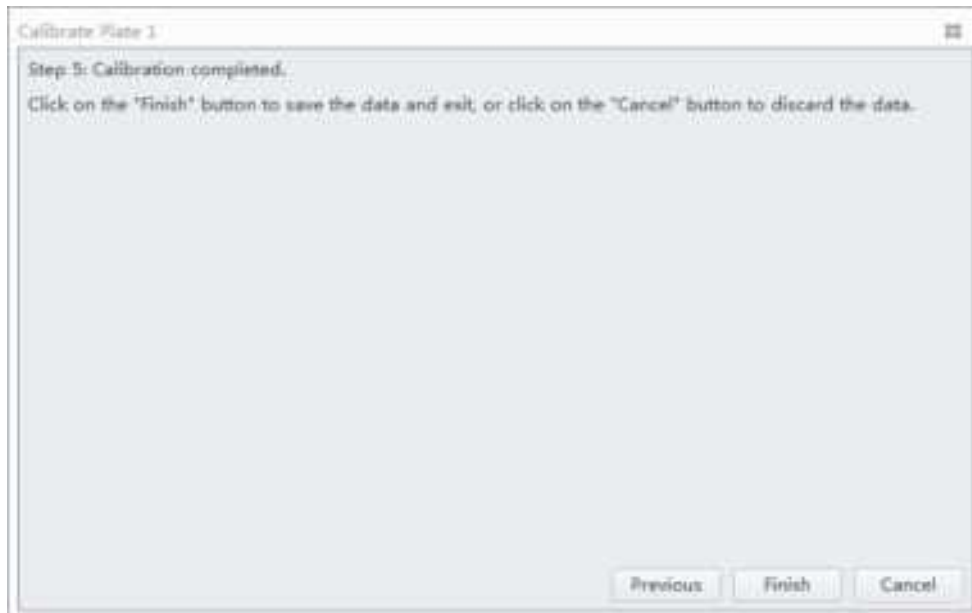
**17** Select **Next** to move to the next well.

**18** Repeat Steps 14-17 for wells A12, H1, and H12.





19 Select **Next**. The calibration completion window appears.



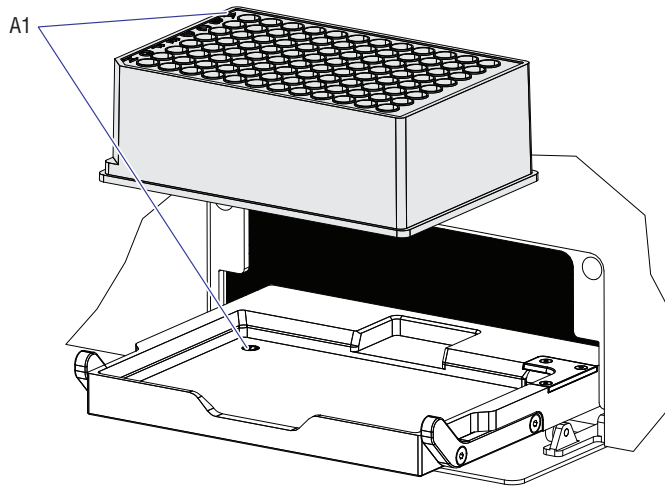
20 [Standard 96-Well Plate]: Select **Finish** to save the settings and exit. Skip to Step 30.

[96-Well Deep Well Plate]: Select **Finish** to save the settings and exit. Continue to calibrate the probe position of Z-axis for the deep well plate. Proceed to Step 21.

**21 [96-Well Deep Well Plate]:** Remove the transparent plate from the plate holder stage.

**22 [96-Well Deep Well Plate]:** Select the plate type which has already been calibrated on the X-axis and Y-axis above on the Plate Type Library window, and place the deep well plate on the plate holder stage.

**[96-Well Deep Well Plate]**

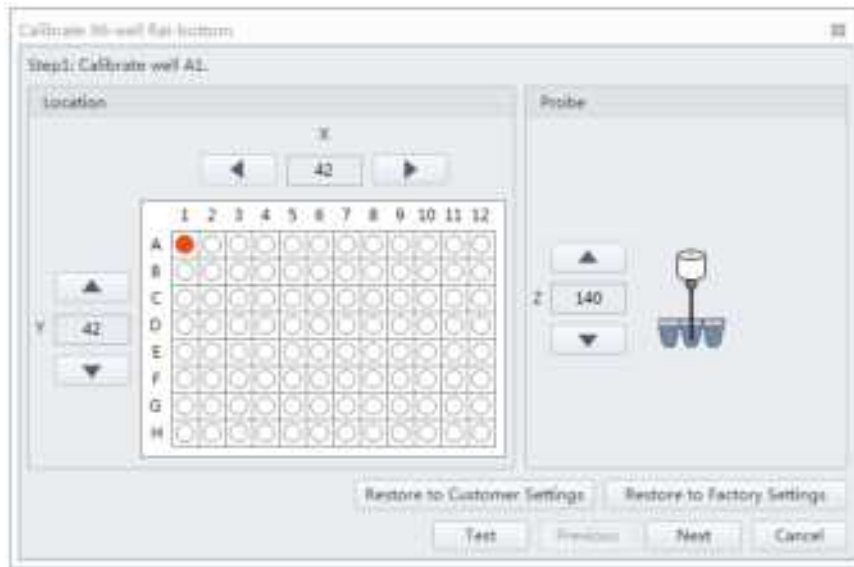


**NOTE** Ensure plate well A1 aligns with position A1.

**23 [96-Well Deep Well Plate]:** Select **Edit** to access the calibrate icon again. The Edit plate window appears.





- 24** Select **Calibrate**. The message *Please confirm that the plate is placed properly and Press Ok.* appears. Select **OK**. The plate loader loads the plate holder stage and the sample probe moves to the sample aspiration position of well A1.



**CAUTION**

**Risk of instrument damage. Do not crash the probe into the bottom of the plate as this will cause irreparable damage to the probe. Move the probe one step at a time when lowering the probe on the Z-axis toward the bottom of the plate. You will hear a click when the probe makes contact with the bottom of the well, this is the extreme position for the Z-axis of the probe. Do not move the probe any lower after you hear the click.**

- 25** [96-well Deep Well Plate]: Select  and  to adjust the sample probe positions in the Z-axis.

Ensure the sample probe is centered and touches the bottom of the well.

**NOTE** The sample probe should just make contact with the bottom of the well.

**NOTE** The probe positions of X-axis and Y-axis have already been calibrated on the transparent plate. Do not continue to adjust the sample probe positions in X-axis and Y-axis.

- 26** [Deep-96 Well Plate]: Select **Test** to verify the sample probe position.

Listen for the click to ensure the probe has made contact with the bottom of the well. Readjust the sample probe position by moving the probe 3 steps upper. This is the correct position for the Z-axis of the probe.

---

**27** [96-Well Deep Well Plate]: Select **Next** to move to the next well.

---

**28** [96-Well Deep Well Plate]: Repeat Steps [25-27](#) for wells A12, H1, and H12.

---

**29** [96-Well Deep Well Plate]: Select **Finish** to save the settings and exit.

---

**30** Reinstall the front cover. Refer to [CHAPTER 12, Front Cover Removal and Reinstallation](#).

---



## Overview

---

**[CytoFLEX]:** Your instrument may have been shipped directly to your laboratory, in which case you will need to set up and connect the Cytometer and the Workstation. Refer to this chapter for the instrument installation procedure.

Validate the environment	→	Open the package	→	Install the instrument	→	Prepare to boot
--------------------------	---	------------------	---	------------------------	---	-----------------

**[CytoFLEX LX]:** The CytoFLEX LX is installed by your Beckman Coulter Service Representative. Do not open the box or crate. Wait for a qualified Beckman Coulter Service Representative.

This chapter contains information on:

- [Instrument Transportation and Storage](#)
- [Installation Environment Validation](#)
- [Unpacking the Instrument and Inspecting the Materials for Defects or Omissions \[CytoFLEX\]](#)
- [CytExpert Software Installation Options](#)
- [Installing the Software \[CytoFLEX Platform\]](#)
- [Upgrading the CytExpert Software](#)
- [Reinstalling the CytExpert Software](#)

## Instrument Transportation and Storage

---

Refer to [CHAPTER 11, Preparing the Instrument for Transport or Storage](#), prior to transportation or storage.

Attention to the following items is required when transporting or storing the instrument:

- Take caution to protect the instrument from exposure to rain or sunlight.
- Always place the instrument on a flat, stable surface, and take note of the symbol for *this side up*.
- Temperature range: see [Temperature and Humidity](#).
- To prevent extrusion, the load on top cannot exceed 100 kg.
- CytoFLEX Cytometer net weight 23 kg, gross weight 27 kg; transport the instrument using only appropriate equipment so as to guard against personal injury.
- CytoFLEX LX Cytometer net weight 83 kg, gross weight 103 kg; transport the instrument using only appropriate equipment so as to guard against personal injury.

## Installation Environment Validation

---

**IMPORTANT** This instrument is intended for indoor use only.

Verify whether the installation environment satisfies the following requirements:

### Worktable



**Risk of instrument damage. Place the instrument on a level surface. Failing to do so places the system in danger of toppling and can result in damage. Take all necessary precautions throughout the process of storing or transporting the instrument.**

- The tabletop must be smooth and level.
- Minimum tabletop load bearing capacity [CytoFLEX]: 50 kg.
- Minimum tabletop load bearing capacity [CytoFLEX LX]: 100 kg.
- The tabletop must not vibrate or shake.
- Minimum tabletop dimensions [CytoFLEX]: 120 cm x 80 cm; minimum vertical space above tabletop: 80 cm.
- Minimum tabletop dimensions [CytoFLEX LX]: 200 cm x 80 cm; minimum vertical space above tabletop: 100 cm.
- Position the instrument in such a manner that it will facilitate disconnection of the power cable at the instrument end.

### Ventilation and Cleaning

**IMPORTANT** If necessary, use ventilation equipment, but airflow must not be allowed to blow directly on the system, as it can affect the reliability of the data.

- Ensure that the working environment is well ventilated for proper heat dissipation.
- Maintain a clearance of at least 20 cm from the back of the instrument for heat dissipation.
- Keep the environment as dust free as possible.
- Avoid direct exposure to sunlight.
- Avoid placing near heat sources or exposing to drafts.
- Avoid corrosives or flammable gases.

## Power Source

**DANGER**

**Risk of electric shock and/or instrument damage. Ensure that the power source is properly grounded. Improper grounding can cause electric shock and damage the system. Verify that the output voltage of the power outlet conforms to the system requirements and that a 5 A, time delay, T 5 AL 250 VAC fuse is installed. To prevent personal injury, Beckman Coulter recommends using a power source designed to protect against electrical shock.**

**CAUTION**

**Possible instrument damage could occur if you use an extension cord or a power strip to connect the Cytometer. Always plug the Cytometer into a dedicated outlet with an isolated ground.**

The power source requirements are as follows:

- This instrument has been tested to and meets all applicable requirements for CE Marking.
- This instrument complies with the emission and immunity requirements described in IEC 61326-1.
- This equipment has been designated and tested to CISPR 11 Class A. In a domestic environment it may cause radio interference, in which case, you may need to take measures to mitigate the interference.
- It is advised that the electromagnetic environment should be evaluated prior to operation of the device.
- Do not use this device in close proximity to sources of strong electromagnetic radiation (unshielded intentional RF sources), as these may interfere with the proper operation.
- 100-240 volts, 50/60 Hz, 3-wire power cable, well grounded.
- Amperage not less than 10 A.
- The system requires a well-grounded power outlet (150 VA normal, 250 VA max) to provide the necessary power.
- Distance from system to socket less than 1.5 m.

Power consumption of the Plate Loader is <30 W.

## Temperature and Humidity



**Risk of instrument damage and/or erroneous results. To ensure reliability, the system must be operated in the specified environment, within the required temperature and humidity ranges. If the ambient temperature or humidity level falls outside the ranges mentioned above, use appropriate air conditioning.**

- **CytoFLEX:** Ambient temperature: 15-27°C with fluctuations of no more than  $\leq \pm 2^\circ\text{C}$  per hour.
- **CytoFLEX LX:** Ambient temperature: 15-30°C with fluctuations of no more than  $\leq \pm 2^\circ\text{C}$  per hour.
- Relative humidity: 15% RH-80% RH, non-condensing.

## Waste Disposal



**Risk of biohazardous contamination if you have skin contact with the waste container, its contents, and its associated tubing. The waste container and its associated tubing might contain residual biological material and must be handled with care. Clean up spills immediately. Dispose of the contents of the waste container in accordance with your local regulations and acceptable laboratory procedures.**

The waste line from the Cytometer is connected to a waste container/cubitainer. Dispose of the system's waste in accordance with your local regulations and acceptable laboratory procedures.

The waste line supplied with the instrument can be connected to an open drain. If you use an open drain, mechanically secure the waste tube into the drain so the tube cannot accidentally come out of the drain. This prevents spillage.

## Unpacking the Instrument and Inspecting the Materials for Defects or Omissions [CytoFLEX]

---

Take care to store the instrument in a suitable environment where it can remain in the proper position.

Check that the following components on the packing list are present:

- Cytometer
- Cables
- Computer

- Mouse
- Keyboard
- Monitor
- Fluid Container holder [CytoFLEX]
- Sheath fluid container
- Waste container
- Sheath fluid tubing
- Waste tubing
- USB configuration key
- Software USB

## Installing the Instrument and Connecting the Equipment [CytoFLEX]

**IMPORTANT** Use the appropriate power cable plug for your geographic region.



**Risk of erroneous results. Place the Fluid Containers and the instrument on the same, level surface. An excessive difference in height can alter the flow velocity.**



**Possible instrument damage could occur if you use an extension cord or a power strip to connect the Cytometer. Always plug the Cytometer into a dedicated outlet with an isolated ground.**

- 
- 1 Remove the Cytometer, the Fluid Containers, the accompanying holder, the computer, the monitor, and the keyboard and mouse from each respective box placing them flat on the instrument worktable.

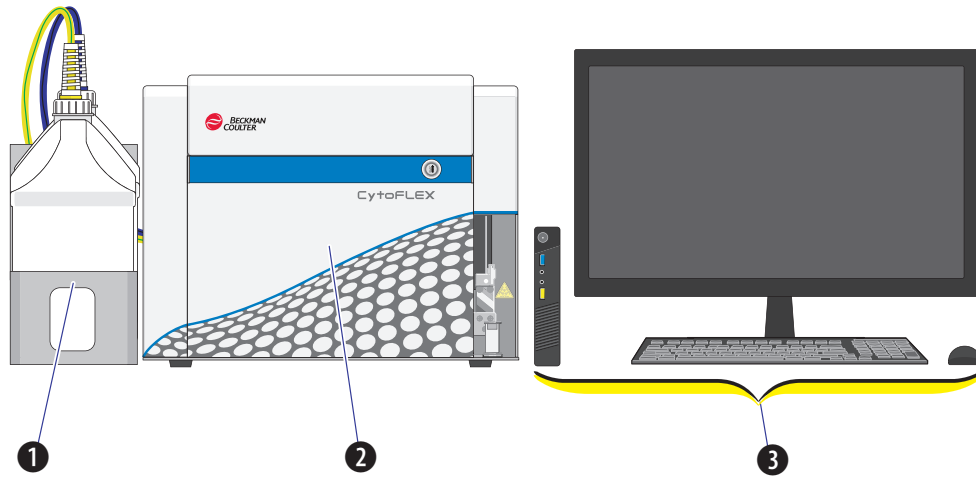
**NOTE** The Fluid Container holder must be on the same plane as the Cytometer.

Reach under the base of the instrument to lift the Cytometer out of the package. Beckman Coulter recommends that two people lift the Cytometer out together.

- 
- 2 Ensure a minimum clearance of 20 cm on both sides and to the back of the Cytometer to maintain enough room to access the on/off controls for the Cytometer devices.

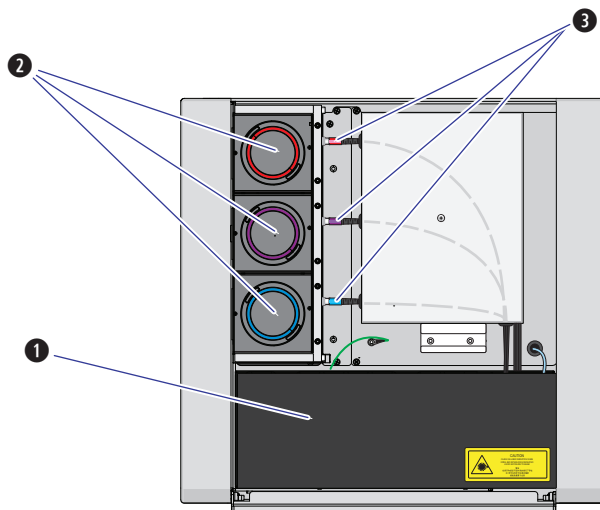
- 3** After removing the monitor and attaching the base, place them on the worktable with the computer.

[CytoFLEX Without Plate Loader Shown]

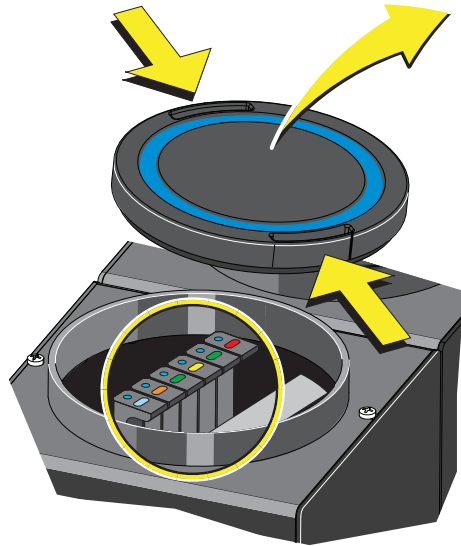


- 1. Fluid Containers.** Place on the left side of the Cytometer.
- 2. Cytometer.** Place between the Fluid Containers and the Workstation.
- 3. Workstation.** Place on the right side of the Cytometer.

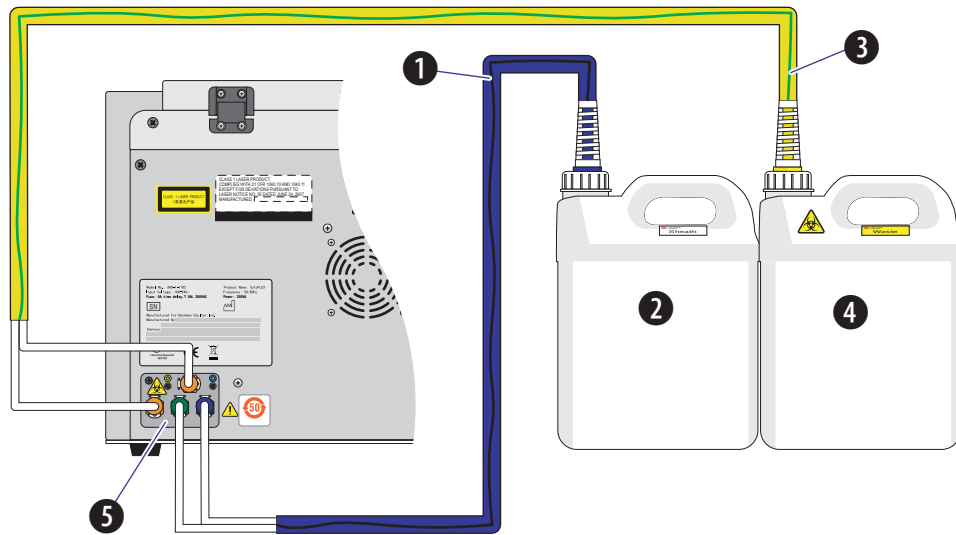
- 4** Open the top cover of the Cytometer. Check inside to verify that the optical bench cover (1) is tightly closed and that the optical fibers (3) and WDMs (2) are securely connected.



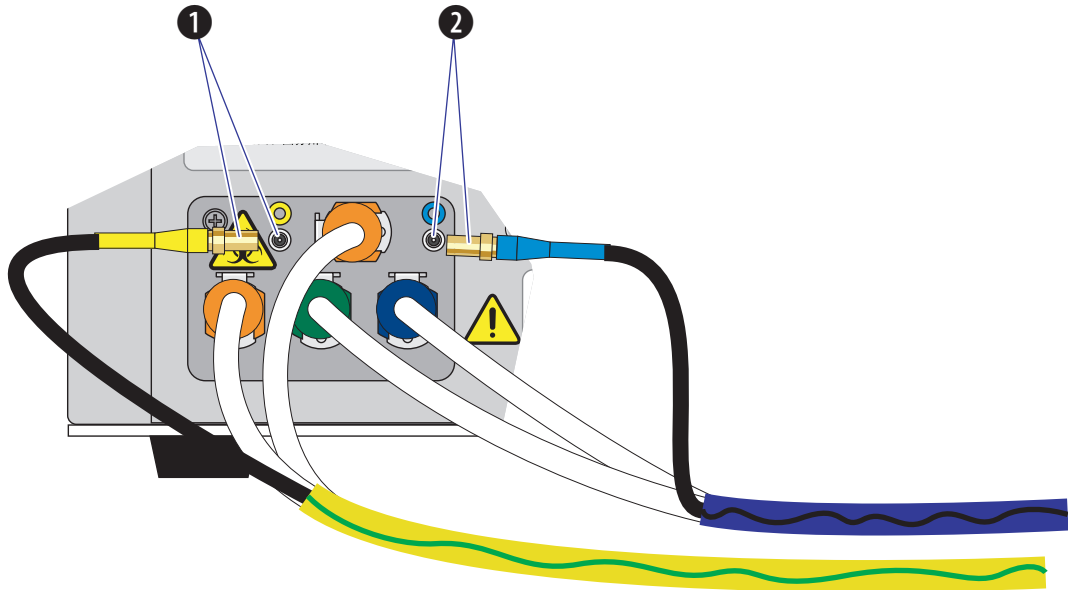
- Remove any shipping tape and open the cap of each WDM. Verify that the light filters inside are in place.



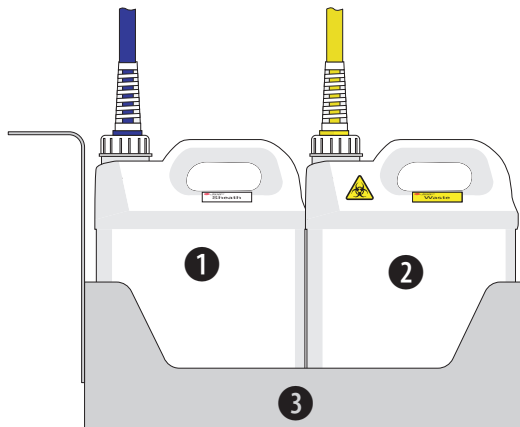
- Insert sheath and waste pickup tubing into the appropriate container.
- Connect the blue harness (1) from the sheath fluid container (2) and the yellow harness (3) from the waste container (4) to the fluid connector panel (5) on the back right corner of the Cytometer according to the color code.



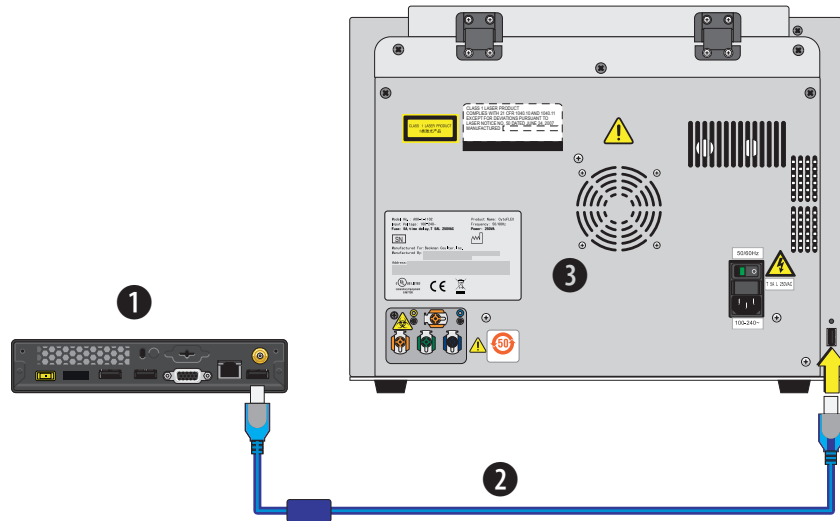
- 
- 8** Connect the waste (1) and sheath (2) level sensors.



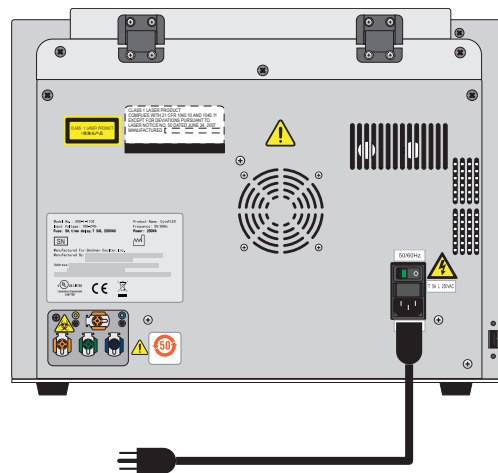
- 
- 9** Place the sheath fluid container (1) and the waste container (2) in the Fluid Container holder (3).



- 10** Set up the supplied computer (1) and connect the USB cable (2) from the back of the Cytometer (3) to a USB port on the back of the computer.



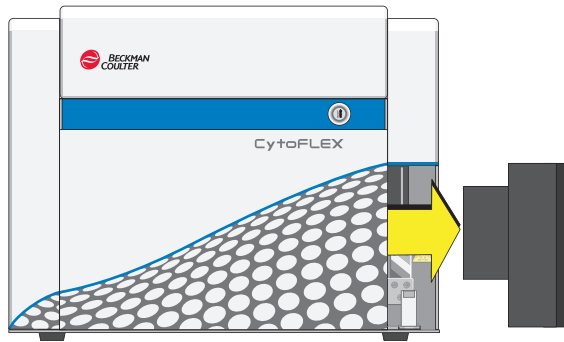
- 11** Plug the Cytometer power cable into the back of the Cytometer.



- 12** Connect the computer keyboard, mouse, and monitor.

- 
- 13** Remove the foam support from the instrument.

[CytoFLEX Without Plate Loader Shown]



- 
- 14** Add Deep Clean solution to the Deep Clean solution bottle. Refer to Step 1 and Steps 3 - 7 of the [CHAPTER 12, Adding the Deep Clean Solution](#).

- 
- 15** Clean the sheath fluid container. Refer to [CHAPTER 11, Cleaning the 4 L Sheath Fluid Container](#).

- 
- 16** Fill the Sheath fluid container. Refer to [CHAPTER 12, Filling the 4 L Sheath Fluid Container](#).

**⚠ WARNING**

**Risk of chemical injury from bleach. To avoid contact with the bleach, use barrier protection, including protective eyewear, gloves, and suitable laboratory attire. Refer to the Safety Data Sheet for details about chemical exposure before using the chemical.**

- 
- 17** Add 400 mL of high-quality, fragrance-free, gel-free bleach (5 to 6% solution of sodium hypochlorite - available chlorine) to the waste container.

- 
- 18** Install the CytExpert software. Refer to [Installing the Software \[CytoFLEX Platform\]](#).

- 
- 19** Turn on the instrument. Refer to [CHAPTER 4, Turning On the Instrument](#).

- 
- 20** Open the CytExpert software. Refer to [CHAPTER 4, Logging into the Software](#).

- 
- 21** Run the System Startup Program. Refer to [CHAPTER 4, Running the System Startup Program \[with the Single Tube Loader\]](#).

---

**22** Prime the instrument three times. Refer to [CHAPTER 12, Priming the Flow Cell](#).

---

**23** Prepare a QC sample. Refer to [CHAPTER 5, Preparing the QC Sample](#).

---

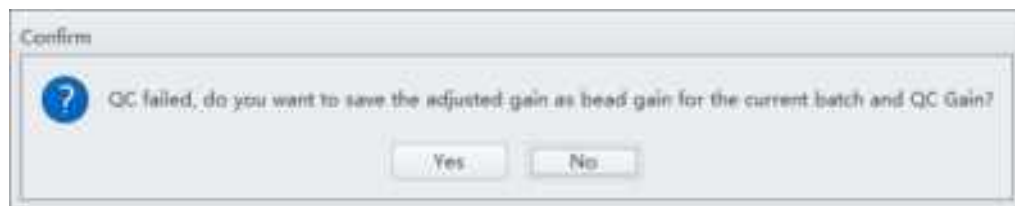
**24** Import the lot-specific target values files. Refer to [CHAPTER 5, Importing Lot-Specific Target Values](#).

---

**25** Perform a QC to establish the target gain values for your instrument. Refer to [CHAPTER 5, Collecting QC Data](#).

---

**26** If the lot number is new and QC fails, the following software message appears. Select **Yes**.



**NOTE** Target gain values must be established for each new lot number of CytoFLEX QC Fluorospheres. QC could fail up to 3 times upon running each new lot number for the first time until target gain values are established.

---

**27** Repeat Steps [23-26](#) until the target gain values are established and QC has passed.

**NOTE** If QC fails more than three times, [contact us](#).

---

**28** Within five business days, activate your Warranty by [contacting us](#) and providing them with your latest QC run results.

---

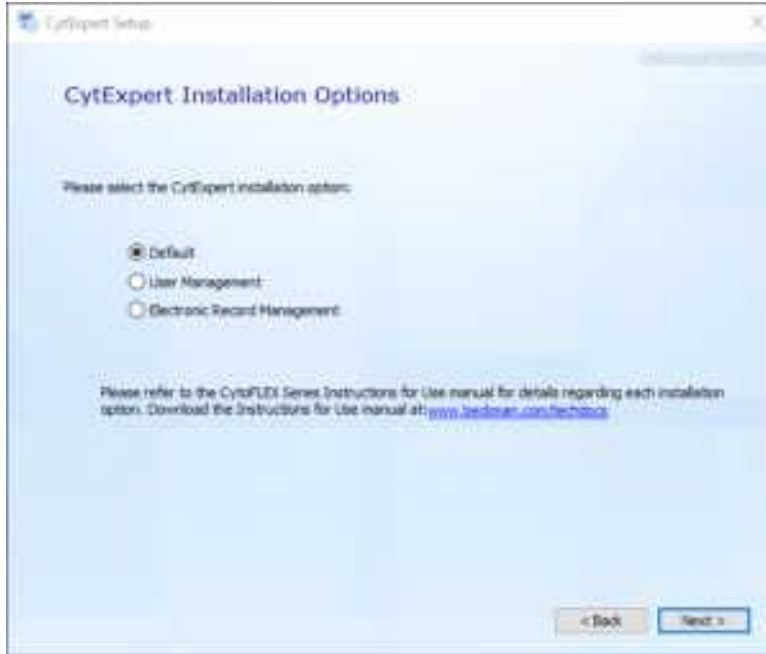
## Installing the Instrument and Connecting the Equipment [CytoFLEX LX]

The CytoFLEX LX is installed by Beckman Coulter service.

## CytExpert Software Installation Options

---

CytExpert software version 2.0 and higher has three installation options upon install.

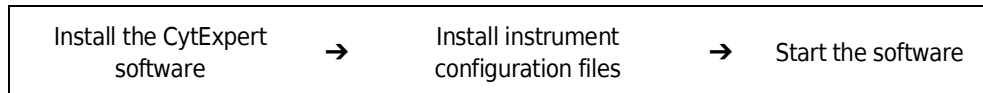


- **CytExpert Default software option.** User Login is not required to run the system.
- **CytExpert User Management software option.** User Login is required to run the system. Contains features and functionality that facilitates user and role management.
- **CytExpert Electronic Record Management software option.** User Login is required to run the system. Contains features and functionality that facilitates compliance with 21 CFR Part 11 guidelines for Electronic Records and Signatures.

## Installing the Software [CytoFLEX Platform]

---

The installation process workflow is as follows:



The CytExpert software can be installed on any computer that meets the minimum specifications (see [CHAPTER 1, Instrument Specifications](#)) for analysis-only use.

## Required Materials

The following materials are required to install the CytExpert software:

- CytoFLEX platform flow cytometer.
- Workstation.
- CytExpert software installation USB.
- Authorized Beckman Coulter CytoFLEX USB configuration key.

## Installing the CytExpert Software

**IMPORTANT** Follow this procedure when installing the CytExpert software for the first time.

- 1 Ensure the workstation and the monitor are powered on.
- 2 Insert the software USB into the computer.

**NOTE** If the Autoplay window appears, select Open folder to view files.



- 3 Select **CytExpert\_Setup\_X.X.exe**. The User Account Control window appears.

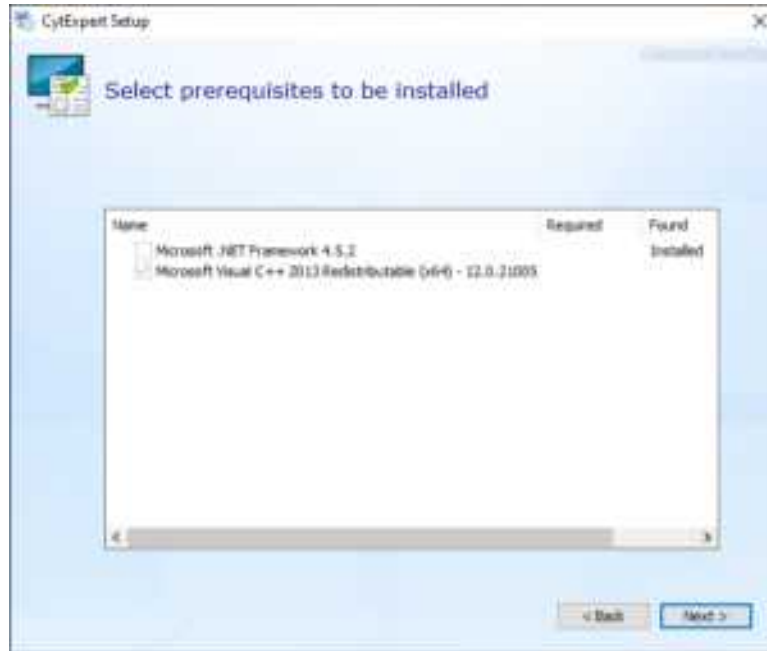


- 4 Select **Yes**. The CytExpert Setup Welcome window appears.



- 5 Select **Next**.

- 6 Select both support program checkboxes in the CytExpert Setup Prerequisites window.

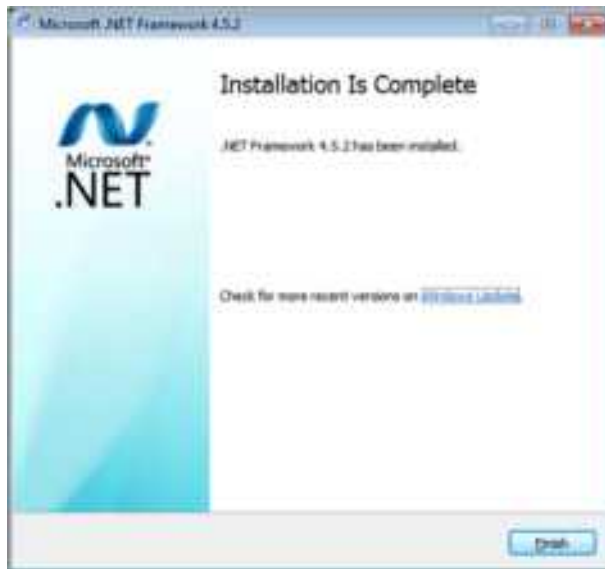


- 7 Select **Next**. The Microsoft .NET Framework window appears.

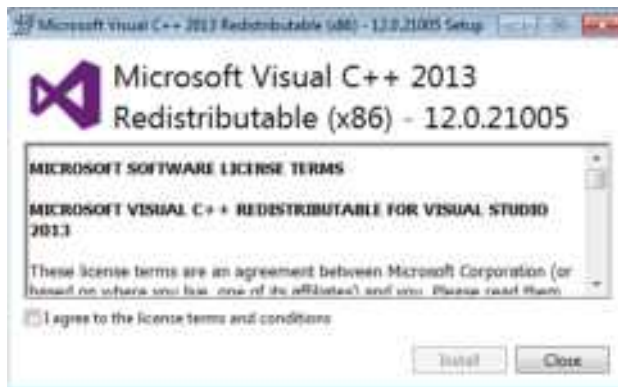


- 8 Select the *I have read and accept the license terms* checkbox.

- 9 Select **Install**. The Installation is Complete window appears when installation has finished.

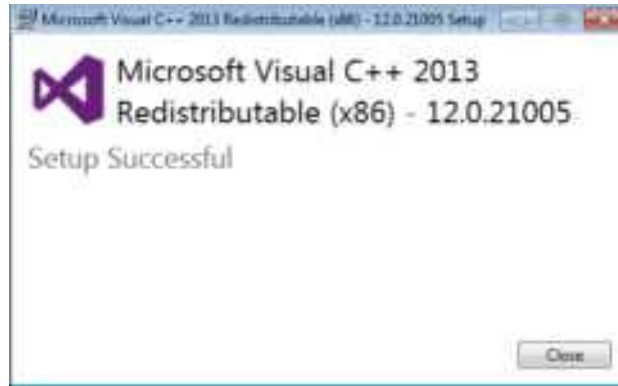


- 10 Select **Finish**. The Microsoft Visual C++ 2013 Redistributable Setup window appears.



- 11 Select the *I have read and accept the license terms* checkbox.

**12** Select **Install**. The Setup Successful window appears when installation has finished.



**13** Select **Close**. The Welcome to the CytExpert Setup Wizard window appears.



- 14 Select **Next**. The Beckman Coulter License Terms window appears.

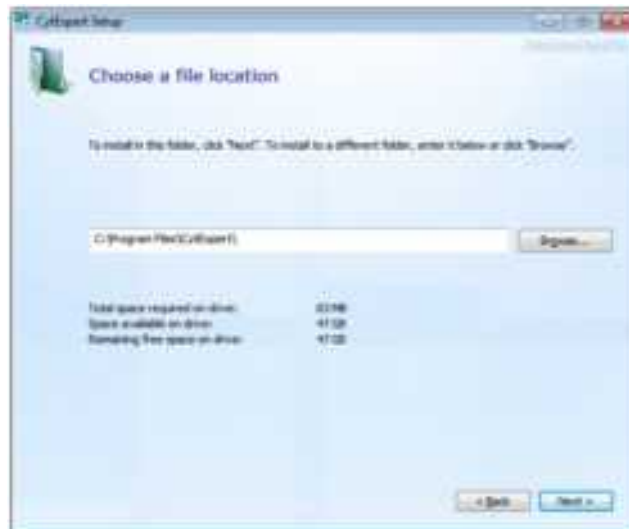


- 15 Read the Beckman Coulter Customer End User License Agreement.

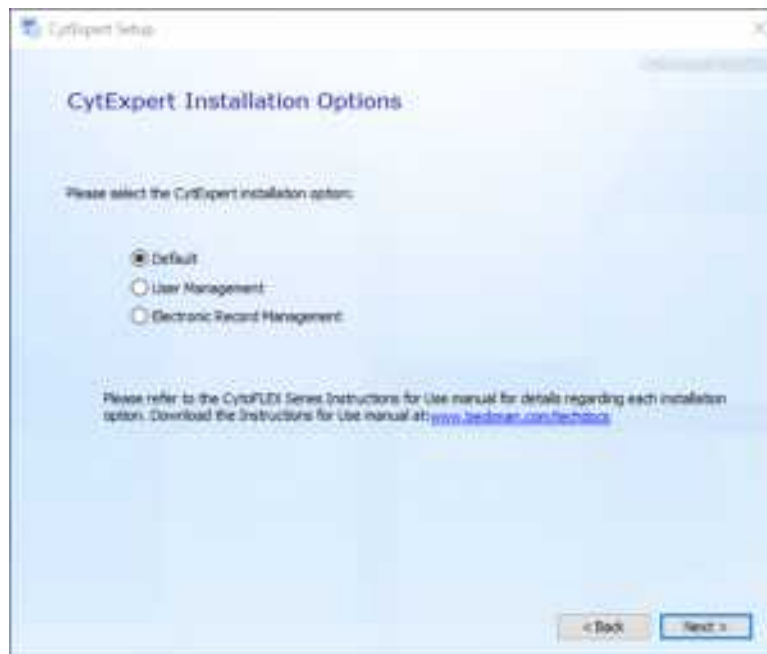
- 16 Select the *I accept the terms of this agreement* checkbox.

**NOTE** The checkbox is not selectable until you scroll all the way to the end of the agreement.

17 Select **Next**. The Choose a file location window appears.



18 Select **Next**. The Installation Options window appears.

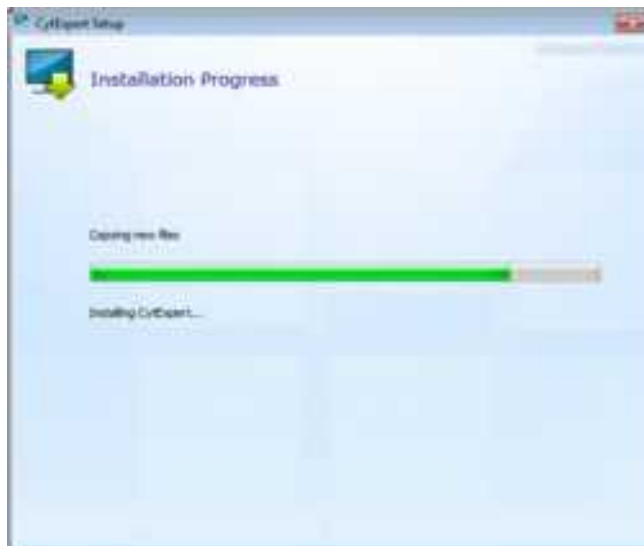


19 Select the desired installation option. Refer to [CytExpert Software Installation Options](#).

**20** Select **Next**. The Begin installation of CytExpert window appears.



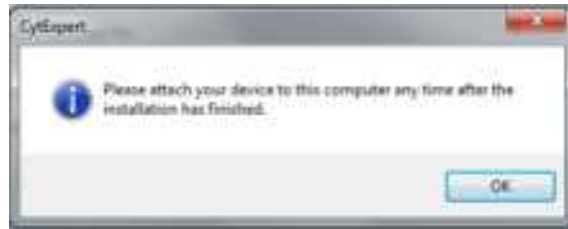
**21** Select **Install** to begin installing the software. The Installation Progress window appears.



**NOTE** The software will install into the default file path provided unless otherwise specified.

---

**22** The following software prompt appears. Select **OK**.



**NOTE** The term "device" in this message refers to the cytometer.

---

**23** Wait for the software to finish installing. The install complete window appears.



---

**24** Select **Close** to finish the CytExpert software installation.

---

**25** Install the instrument configuration file. Refer to [Installing the Instrument Configuration File](#).

---

## Installing the Instrument Configuration File



**Risk of erroneous results or instrument damage. Only install the configuration file that matches your instrument. Installing an incorrect configuration file could cause erroneous results or instrument damage.**

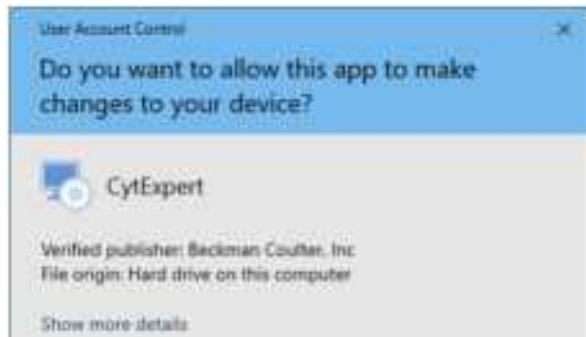
Use this procedure to install the configuration settings for the instrument. If the CytExpert software will not be connected to a Cytometer, this step can be skipped.

---

**IMPORTANT** You must install the CytExpert software before installing the instrument configuration file. Refer to [Installing the Software \[CytoFLEX Platform\]](#).

- 1 Select and run **CytExpert\_X.X\_Config\_Setup\_XXXX.exe**. The User Account Control window appears.

**NOTE** XXXX refers to the serial number of the instrument.



- 2 Select **Yes**. The CytExpert Config Welcome window appears.



- 3 Select **Next**. The CytExpert Config Ready to Install window appears.



- 4 Verify that the serial name displayed at the top of the window is correct.

- 5 Select **Install**. When the installation has finished, the Completing the CytExpert Config Setup Wizard window appears.



- 6 Select **Finish**.

- 7 If you get the following message, select **OK**. When you launch CytExpert, the system will automatically upgrade your configuration file.



## Starting the Software

**IMPORTANT** The default username is *admin*. The default password is *password*.

- 1 Insert the USB configuration key into the USB port of the computer.
- 2 Start the software. Refer to [CHAPTER 4, Logging into the Software](#), for detailed instructions on opening the software and confirming the connection status.

**NOTE** If the software shows *Connected*, data collection and analysis can be completed.

## Upgrading the CytExpert Software

Use this procedure to upgrade to software version 2.0 or higher from any previous version.

If you only need to upgrade to the CytExpert Default software option, you should follow the procedure below.

If you need to install either the CytExpert User Management software option or the CytExpert Electronic Record Management software option, you should first follow the procedure below then follow the reinstallation procedure. Refer to [Reinstalling the CytExpert Software](#).

Refer to [CytExpert Software Installation Options](#) for the differences between each software option available.

**CAUTION**

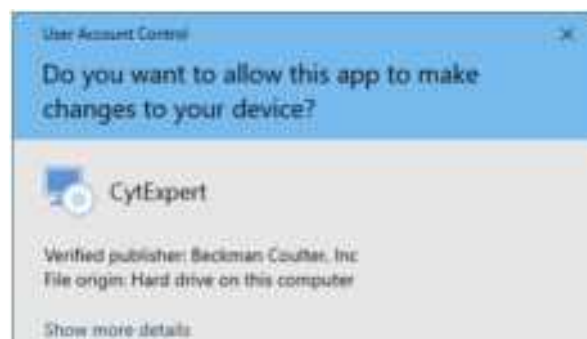
**Risk of data loss. Reinstalling the CytExpert Software could overwrite your database. Ensure you backup your database prior to software reinstallation.**

- 1 Insert the software USB into the computer.

**NOTE** If the Autoplay window appears, select Open folder to view files.



- 2 Select **CytExpert\_X.X\_Setup.exe**. The User Account Control window appears.



- 3 Select **Yes**. The Welcome to CytExpert Setup Wizard window appears.



- 4 Select **Next**. The Beckman Coulter License Terms window appears.

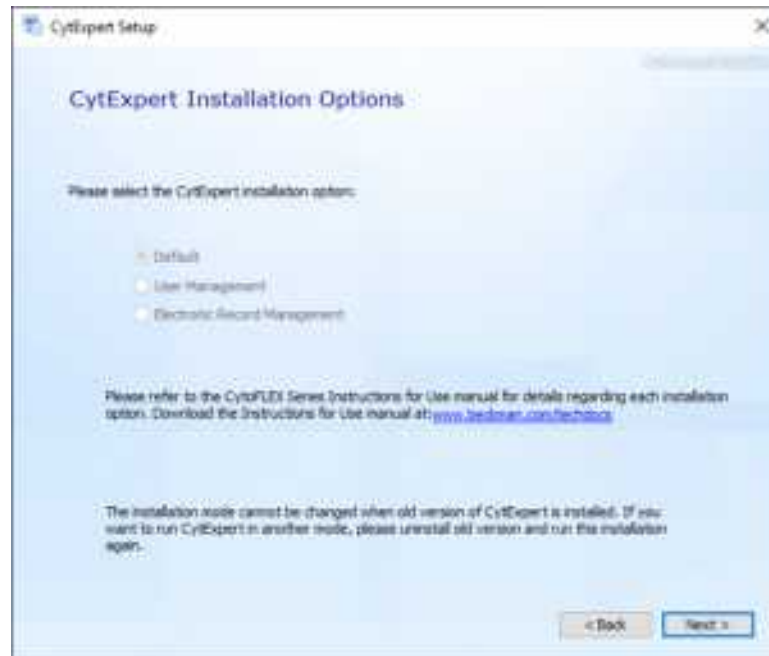


- 5 Read the Beckman Coulter Customer End User License Agreement.

6 Select the *I accept the terms of this agreement* checkbox.

**NOTE** The checkbox is not selectable until you scroll all the way to the end of the agreement.

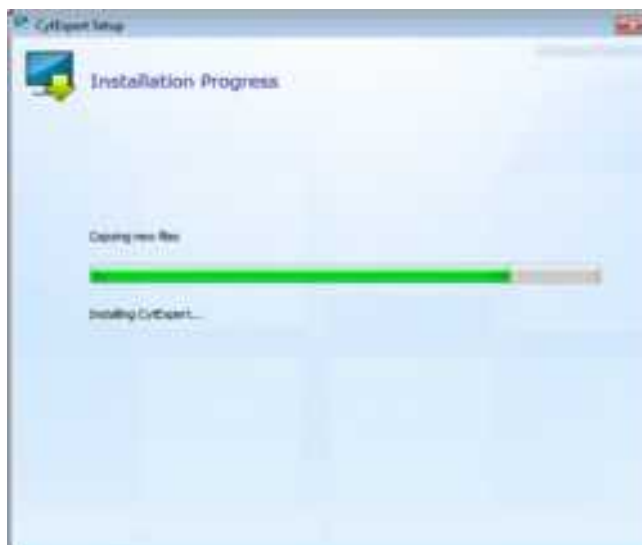
7 Select **Next**. The Installation Options window appears.



- 8 Select **Next**. If you are upgrading your software from a previous version and the previous version is not uninstalled first, the following window appears.



- 9 Select **Install** to begin installing the software. The Installation Progress window appears.



- 10 If the following software prompt appears, select **OK**.



**NOTE** The term “device” in this message refers to the cytometer.

- 11 Wait for the software to finish installing. The install complete window appears.



- 12 Select **Close** to finish the CytExpert software installation.

## Reinstalling the CytExpert Software

Use this procedure to:

- Change the software option installed in all software versions 2.0 and higher. Refer to [CytExpert Software Installation Options](#) for the differences between each software option available.

**NOTE** If you are upgrading to software version 2.0 or higher from any software version prior to software version 2.0, refer to [Upgrading the CytExpert Software](#).

- Reinstall the same version of software.
- Upgrade your software to a version newer than software version 2.0.

**⚠ CAUTION**

**Risk of data loss. Reinstalling the CytExpert Software could overwrite your database. Ensure you backup your database prior to software reinstallation.**

---

**1** Backup your CytExpert data if you previously had a software option other than the Default software option installed. Refer to [CHAPTER 10, Backup and Restore](#).

---

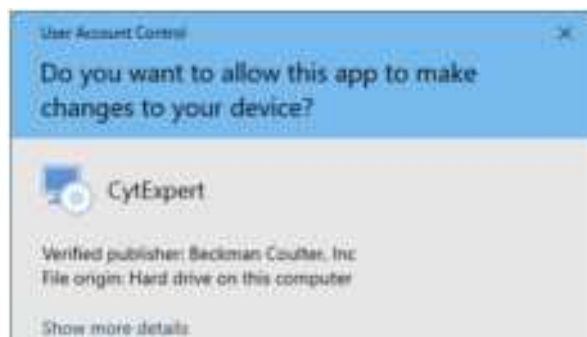
**2** Insert the software USB into the computer.

**NOTE** If the Autoplay window appears, select Open folder to view files.



---

**3** Select **CytExpert\_X.X\_Setup.exe**. The User Account Control window appears.



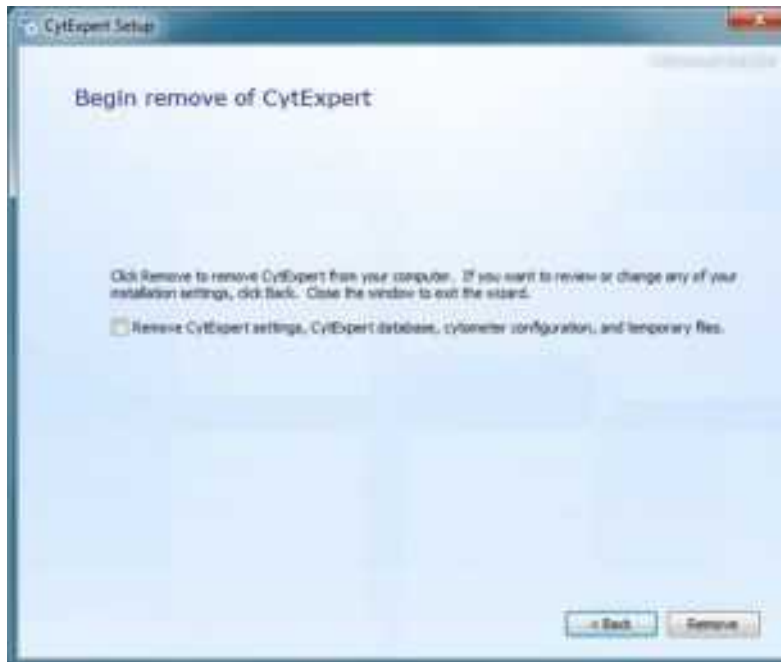
- 4 Select **Yes**. The Welcome to CytExpert Setup Wizard window appears.



- 5 Select **Next**. The Change your installation of CytExpert screen appears.



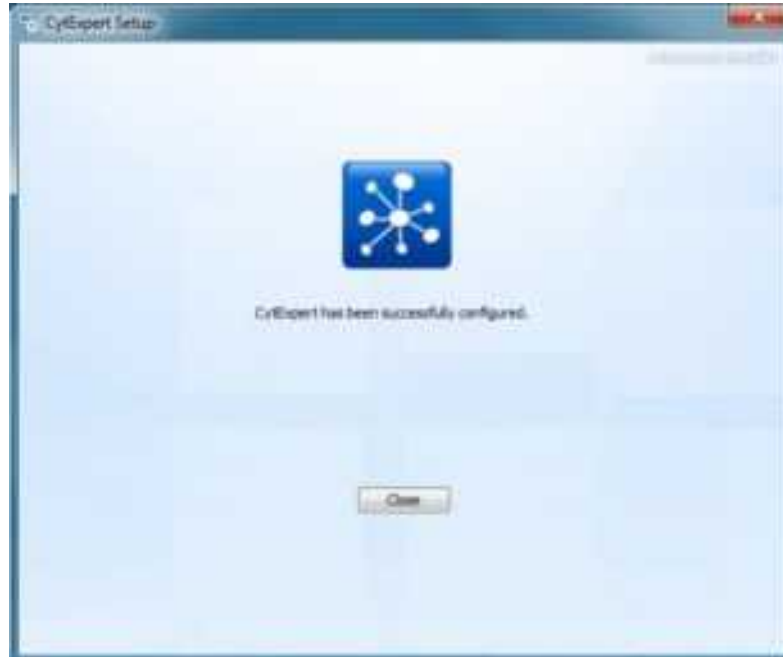
- 6 Select **Remove**. The Begin Remove of CytExpert screen appears.



**IMPORTANT** If the *Remove CytExpert settings, CytExpert database, cytometer configuration, and temporary files* checkbox is checked, your settings, database, configuration files, and temporary files will be overwritten and you will need to reinstall your cytometer configuration and restore any databases you might have.

- 7 Ensure the *Remove CytExpert settings, CytExpert database, cytometer configuration, and temporary files* checkbox is unchecked.

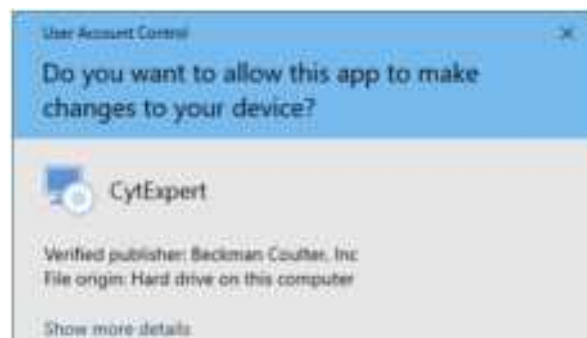
- 
- 8 Select **Remove**. When software removal is complete, the software displays the message *CytExpert has been successfully configured*.



- 
- 9 Select **Close**.

- 
- 10 Navigate back to the software USB folder.

- 
- 11 Select **CytExpert\_X.X\_Setup.exe**. The User Account Control window appears.



12 Select **Yes**. The Welcome to CytExpert Setup Wizard window appears.



13 Select **Next**. The Beckman Coulter License Terms window appears.



14 Read the Beckman Coulter Customer End User License Agreement.

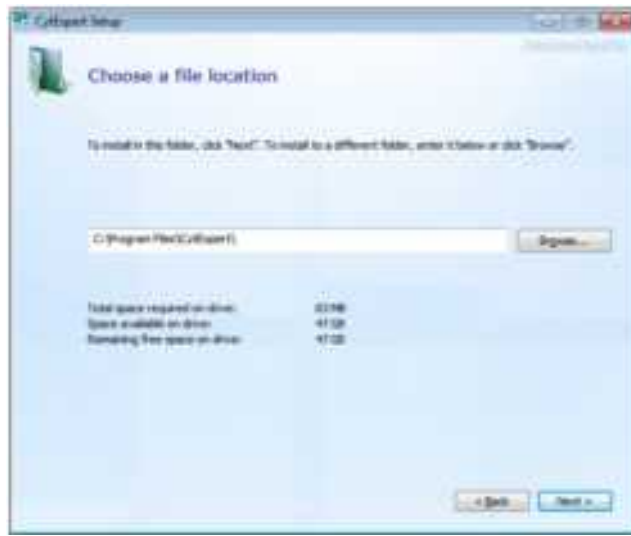
---

**15** Select the *I accept the terms of this agreement* checkbox.

**NOTE** The checkbox is not selectable until you scroll all the way to the end of the agreement.

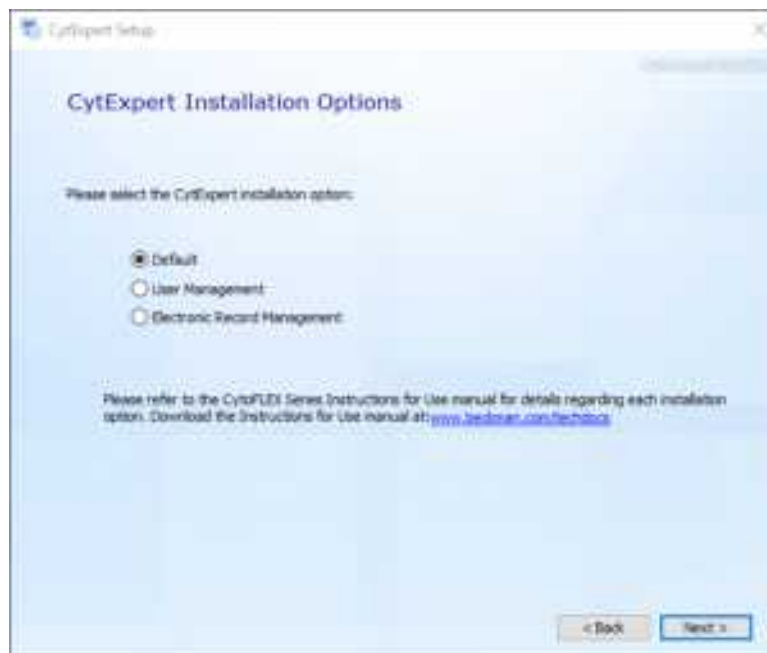
---

**16** Select **Next**. The Choose a file location window appears.



---

**17** Select **Next**. The Installation Options window appears.



---

**18** Select the desired installation option. Refer to [CytExpert Software Installation Options](#).

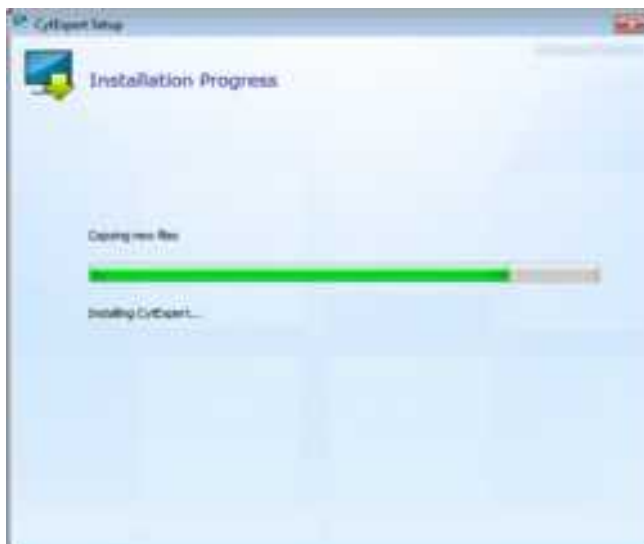
---

**19** Select **Next**. The Begin installation of CytExpert window appears.



---

**20** Select **Install** to begin installing the software. The Installation Progress window appears.



---

**21** If the following software prompt appears, select **OK**.



**NOTE** The term "device" in this message refers to the cytometer.

---

**22** Wait for the software to finish installing. The install complete window appears.



---

**23** Select **Close** to finish the CytExpert software installation.

---



# CytExpert Electronic Record Management

## Overview

---

**IMPORTANT** You must have the CytExpert Electronic Record Management software option installed to use the features listed below. Refer to [APPENDIX A, CytExpert Software Installation Options](#).

Beckman Coulter's CytoFLEX with CytExpert software version 2.0 and higher contains features and functionality that facilitates compliance with 21 CFR Part 11 guidelines for Electronic Records and Signatures. This electronic record management includes controls for user identification, permissions, electronic signatures, data integrity, operation and experiment logs and audit trails. CytExpert software version 2.0 and higher contains a database that uses checksum matching to prevent tampering of the records and files that are indexed in the Closed File System.

This chapter contains information on:

- [Software Menu](#)
- [Experiment Management](#)
- [Log](#)
- [Electronic Signature](#)
- [User Management](#)

## Software Menu

---

The CytExpert Electronic Record Management software option includes additional software menu items that are not available in the CytExpert Default software option or the CytExpert User Management software option. Refer to [Figure 2.3](#) and [Figure 2.4](#) for comprehensive software menu trees and details on which menu item applies to each software option.

## Experiment Management



### CAUTION

**Risk of file corruption. Do not add, delete, or modify data from the Windows Explorer directory. Manage all data changes using Experiment Explorer to ensure file indexing remains intact.**

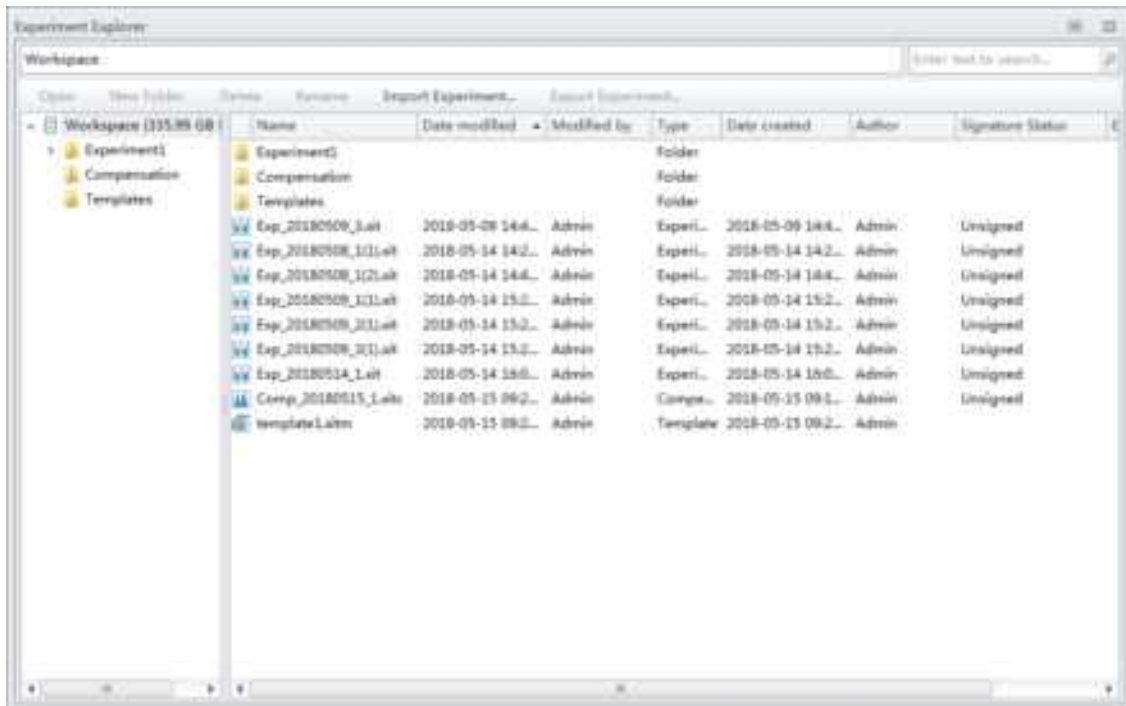
## Closed File System

The closed file system provides audit trail capability for CytExpert experiment files. The closed file system provides a secure layer between the actual Windows Explorer files and the CytExpert users to retain file integrity.

Three file types are managed by the closed file system:

- Experiment files
- Compensation experiment files
- Experiment template files

The Experiment Explorer dialog can be accessed by selecting **File > Experiment Explorer**. The Experiment Explorer dialog functions similarly to Windows Explorer.



Experiments, compensation experiments, and experiment templates created in other modes can be imported into the closed file system. These closed file system experiments can also be exported. Refer to [Importing an Experiment/Template](#) and [Exporting an Experiment/Template](#).

## Experiment Directory Management

When launching CytExpert for the first time after installing the software, the Administrator must set up at least one experiment directory for experiment files.

**NOTE** Only one experiment directory can be created per drive.

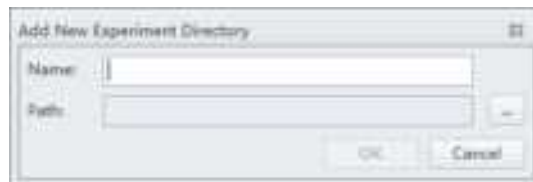
### Setting Up the Experiment Directory


---

- 1 Select **Settings > Set Experiment Directory**. The Set Experiment Directory window appears.



- 2 Select **Add**. The Add New Experiment Directory window appears.



- 3 Enter a name for the experiment directory.
- 4 Select  and browse to the desired Windows file system folder.

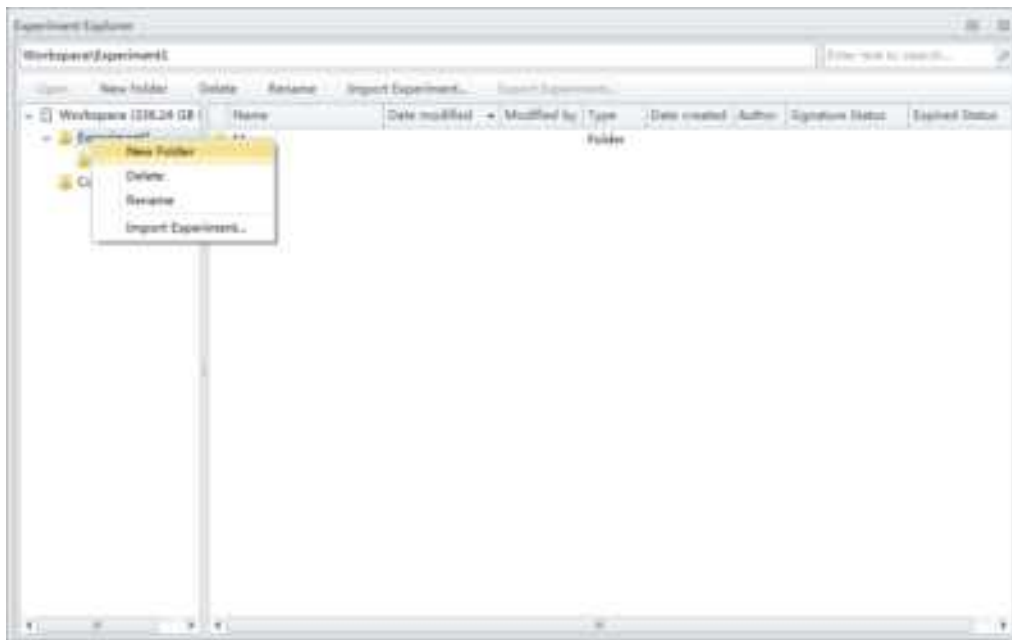
- 5 Select **OK**. The specified folder appears in the Set Experiment Directory window.



**NOTE** Select **Rename** to rename the experiment directory. Select **Delete** to delete an experiment directory.

## Folder Hierarchy Management

Select **File > Experiment Explorer** to view Experiment Explorer. Select **New Folder** from the right-click drop down menu or from the Experiment Explorer toolbar to create a new subfolder.

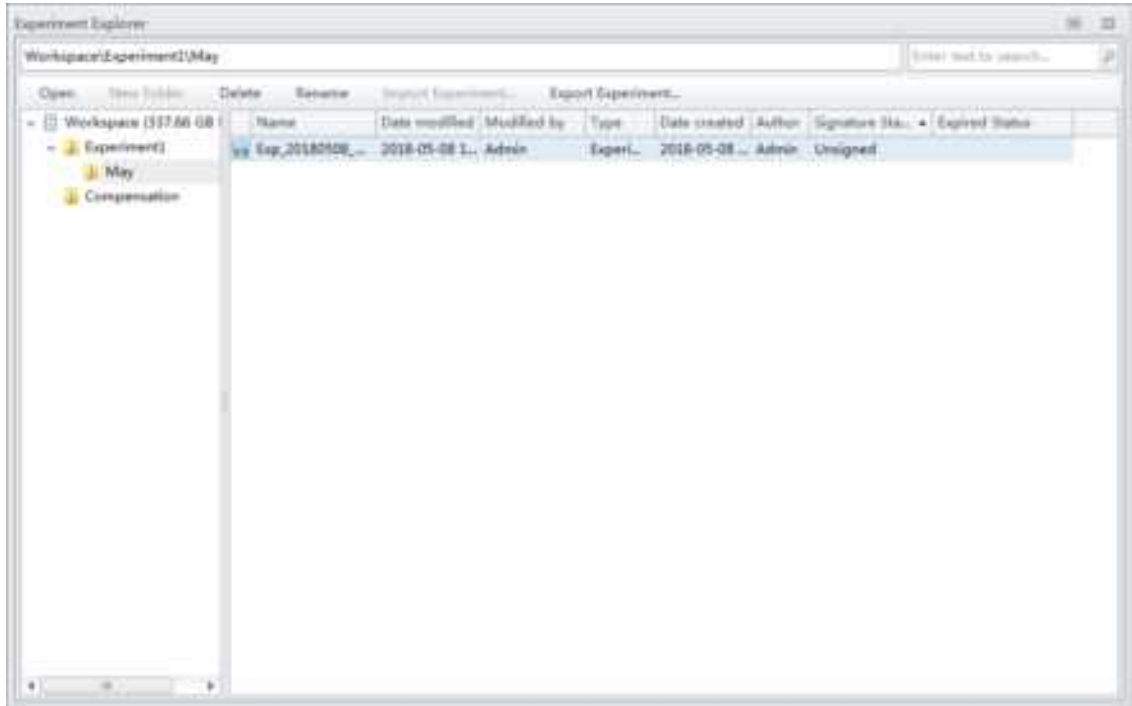


Select **Rename** from the right-click drop down menu or from the Experiment Explorer toolbar to rename a subfolder.

Select **Delete** from the right-click drop down menu or from the Experiment Explorer toolbar to delete a subfolder.

## Experiment Related Operations

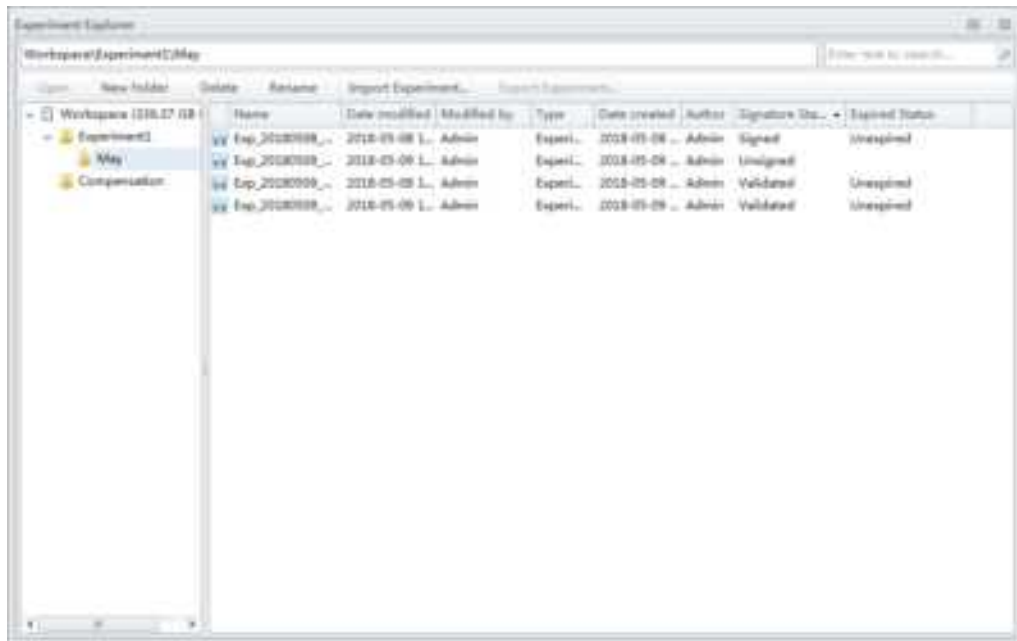
The Experiment Explorer dialog appears in place of the Windows File Explorer in the following operations: New/Open Experiment, New/Open Compensation Experiment, Save As, Save Experiment As Template, Recent Template, and New Experiment from Template.



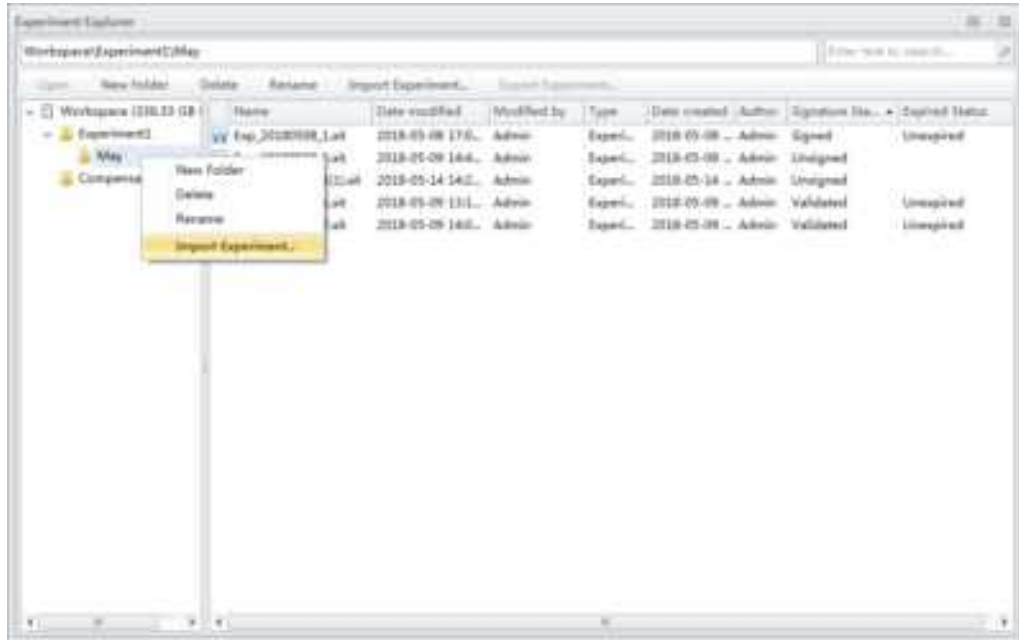
## Importing an Experiment/Template

Use the following procedure to import experiment (.xit), compensation (.xipc), or experiment from template (.xitm) files into the system.

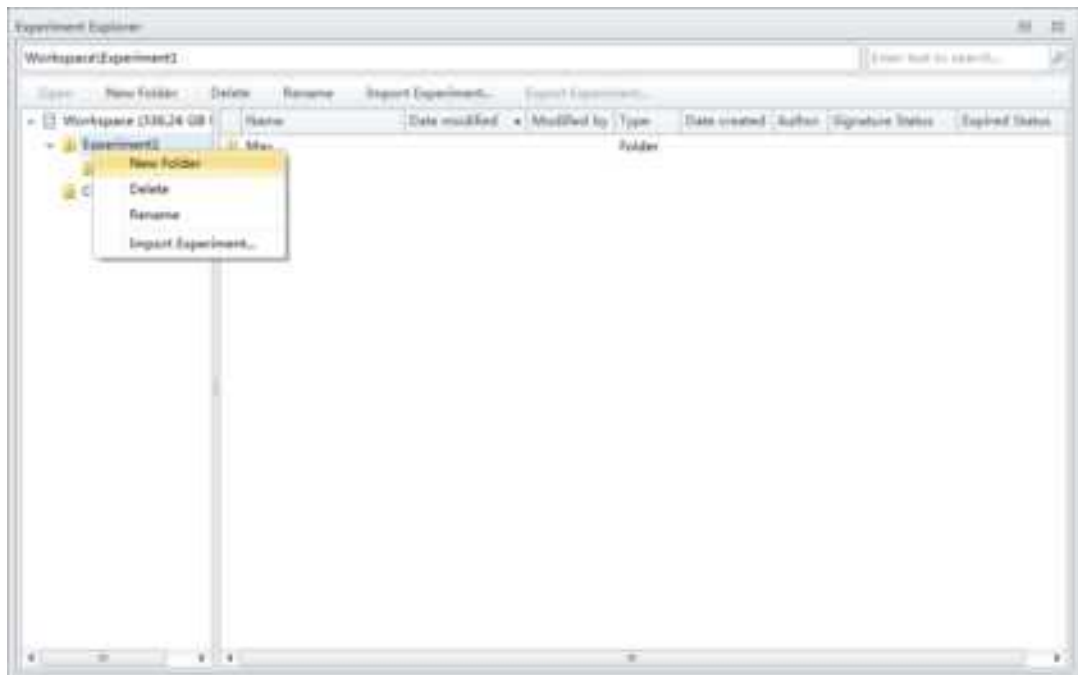
- 1 Select **File > Experiment Explorer**. The Experiment Explorer window appears.



- 2 Select **Import Experiment** from the right-click drop down menu or from the Experiment Explorer toolbar.



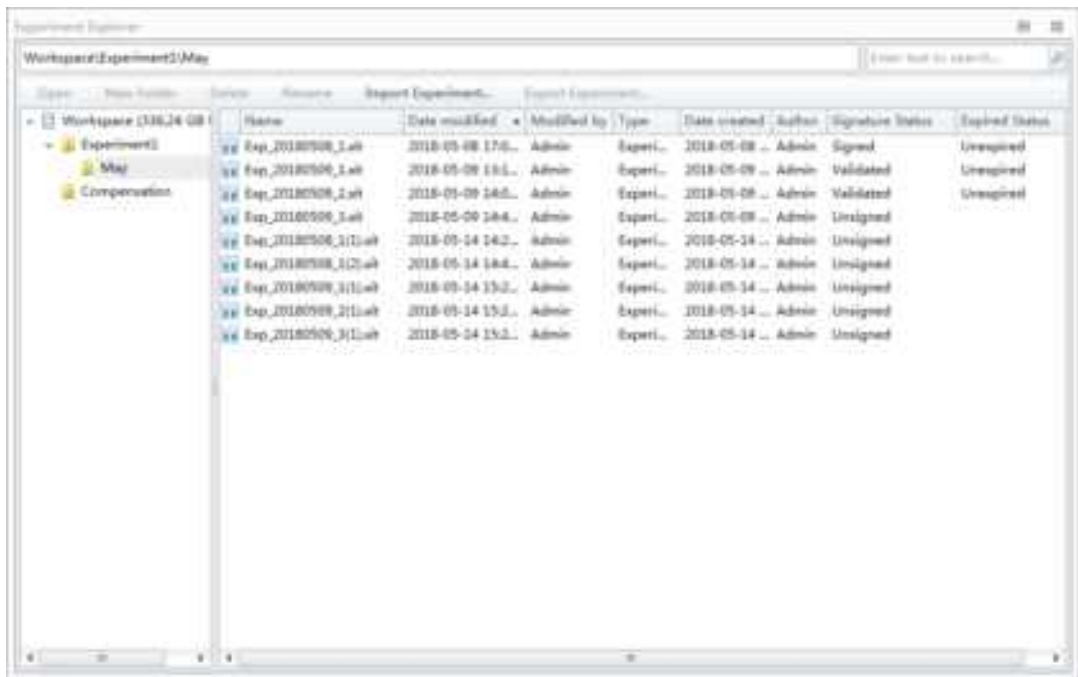
- 3 Browse to the desired file path to import and select **Open**.



A progress bar appears when importing files.



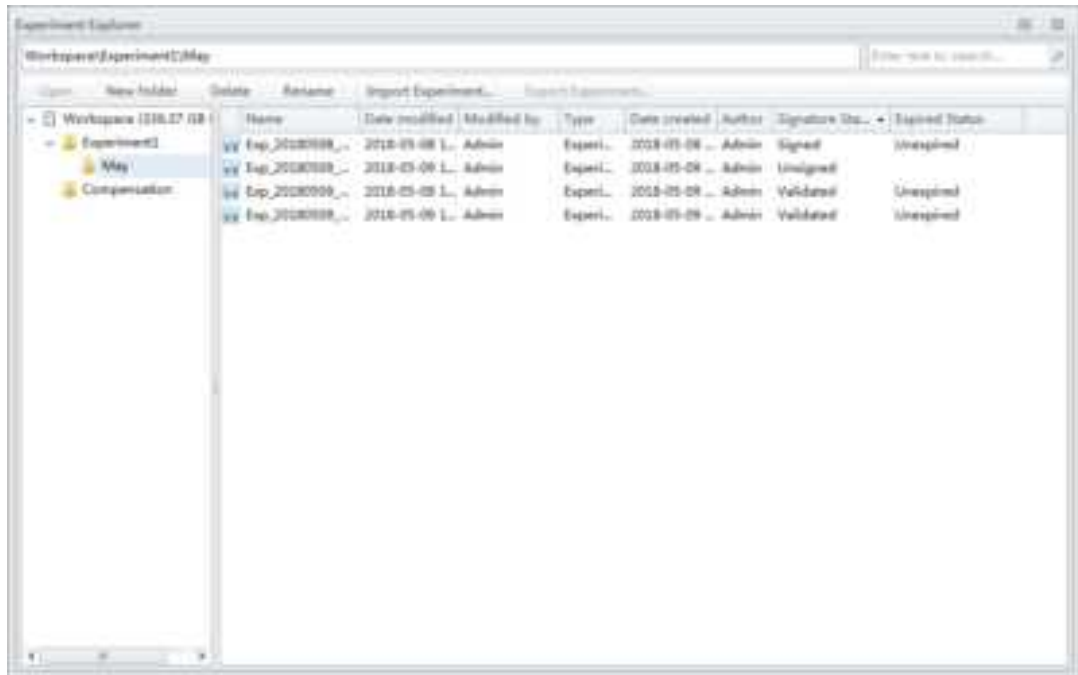
Once the import is complete, the imported files display in the Experiment Explorer.



**NOTE** Users can import .xit, .xitc, and .xitm files individually or multiple files at a time.

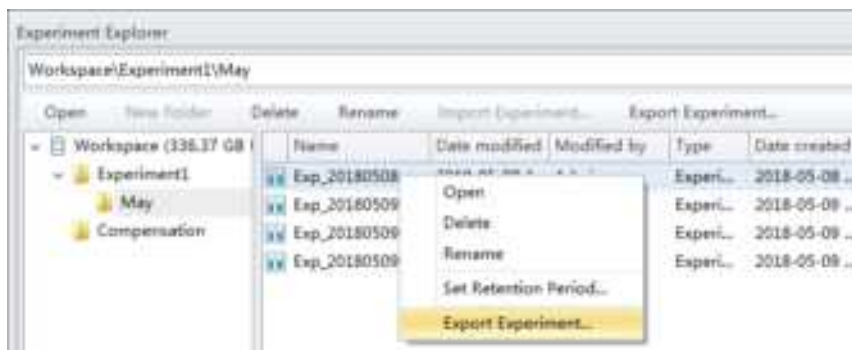
## Exporting an Experiment/Template

- 1 Select **File > Experiment Explorer**. The Experiment Explorer window appears.

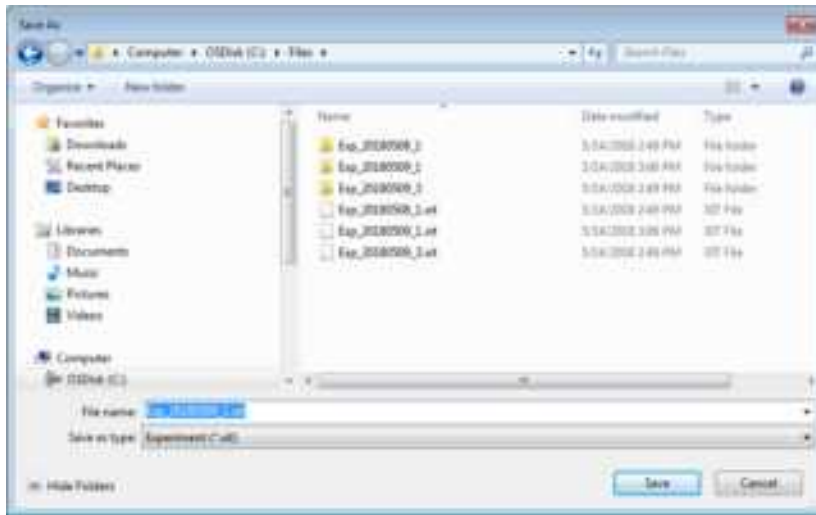


- 2 To export a single experiment:

- a. Select **Export Experiment** from the right-click drop down menu or from the Experiment Explorer toolbar.



- b. Browse to the desired file path for export and select **Save**.



A progress bar appears when exporting files.

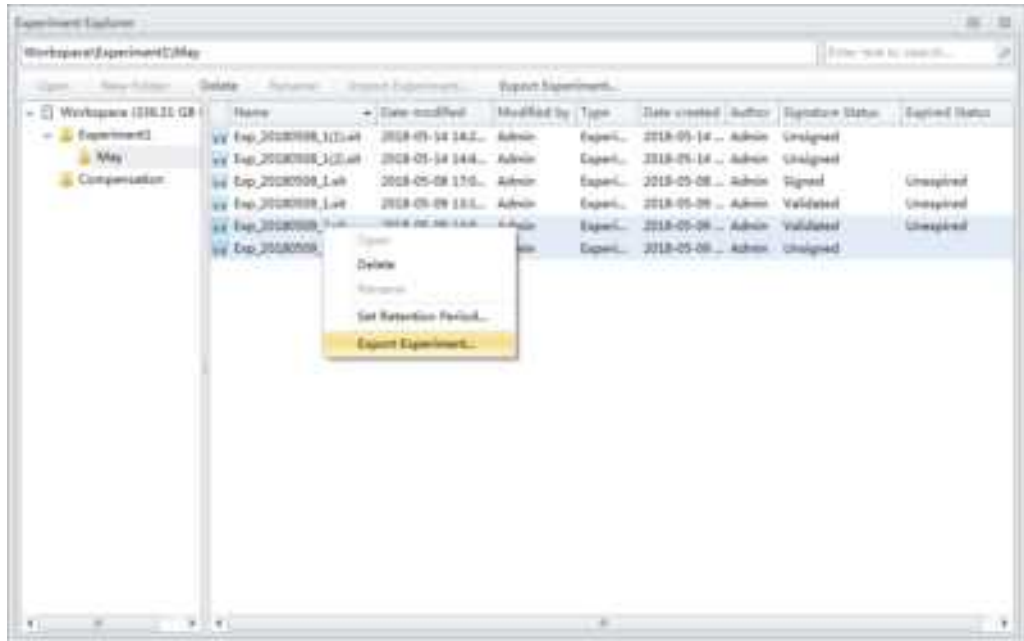


Once the export is complete, the exported file displays in the target folder.

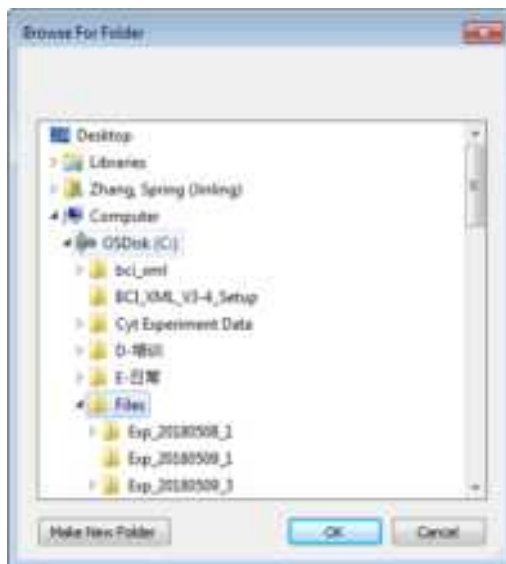
OR

To export multiple experiments:

- a. Select all of the experiments to be exported then select **Export Experiment** from the right-click drop down menu or from the Experiment Explorer toolbar.



- b. Browse to the desired file path for export and select **OK**.



A progress bar appears when exporting files.



Once the export is complete, the exported file displays in the target folder.

## Log

---

The CytExpert Electronic Record Management software option includes three logs:

**Experiment Operation Log** — The experiment operation log lists the audit trail records related to the experiment operations based on query criteria.

**System Operation Log** — The system operation log lists the log records associated with the system configuration changes based on query criteria.

**User Management Operation Log** — The user management operation log lists all of the log records related to the user management operations based on query criteria.

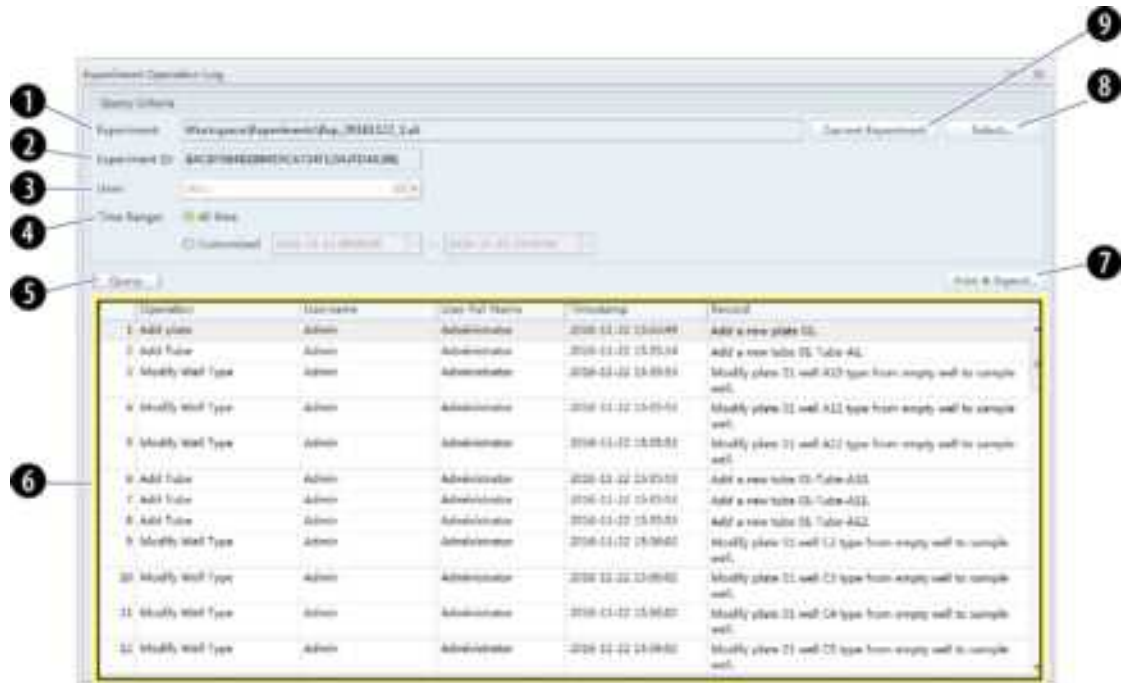
**NOTE** All three logs support print and export to PDF or CSV file functions.

### Experiment Operation Log

The Experiment Operation Log generates an experiment audit trail record when performing experiment operations.

Select **Log > Experiment Operation Log** to open the Experiment Operation Log window. Refer to [Figure B.1](#).

Figure B.1 Experiment Operation Log Window



1. **Experiment:** Used to specify the experiment file criteria.

**NOTE** If an experiment is open, the current experiment displays in the Experiment section.

2. **Experiment ID:** Used to specify the experiment ID query criteria.

3. **User:** Used to specify the user query criteria.

**NOTE** The default selection all users.

4. **Time range:** Used to specify the operation time range query criteria.

5. **Query** : Runs the query on the specified query criteria.

6. **Query display:** Displays the queried results.

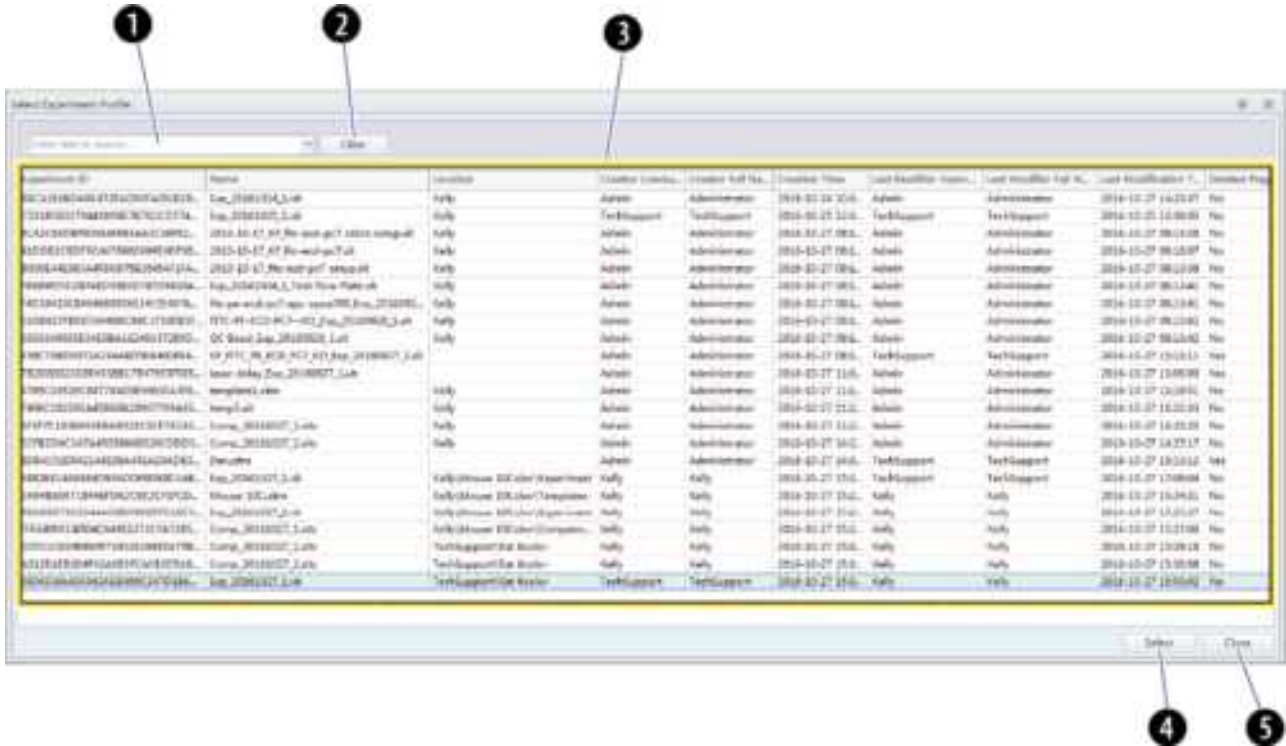
7. **Print & Export...** : Displays the print and export preview dialog. Refer to [Figure B.3](#).

8. **Select...** : Selects an experiment from the Select Experiment Profile window. Refer to [Figure B.2](#).

9. **Current Experiment** : Selects the experiment that is currently open.

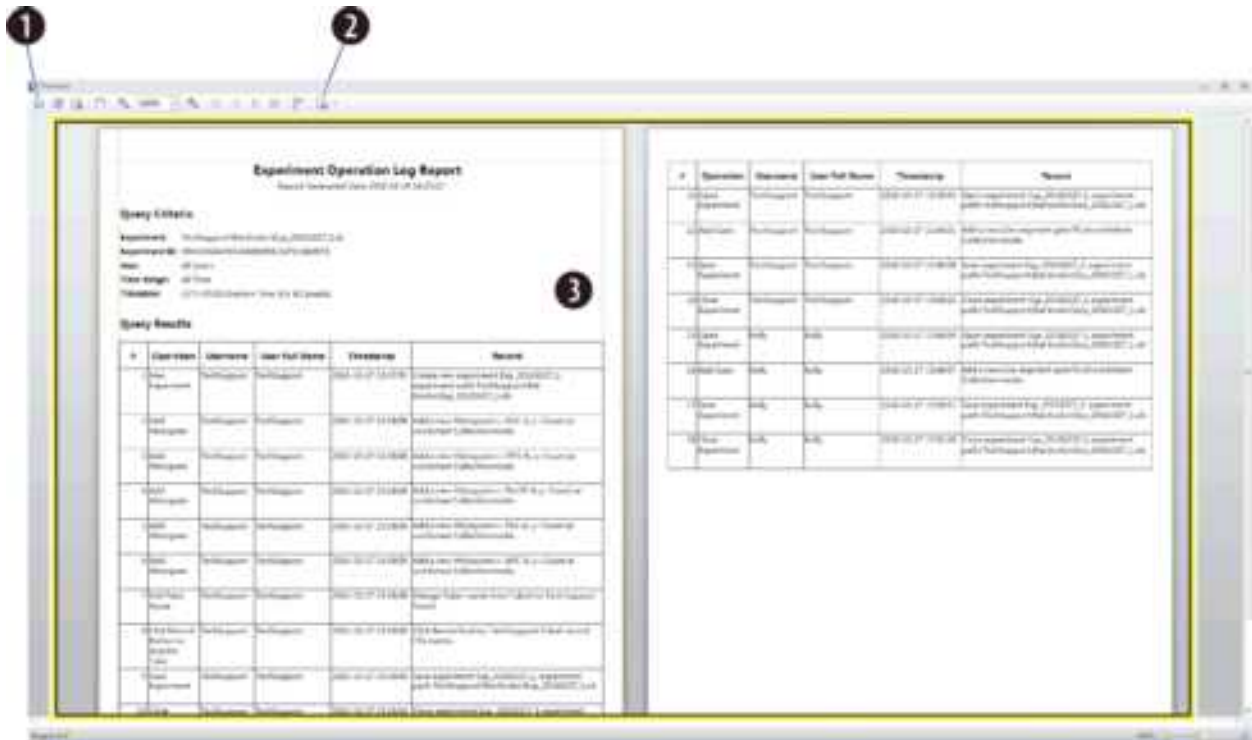
**NOTE** An experiment must be open for the button to be selectable.

Figure B.2 Select Experiment Profile Window



- 1. Keyword search:** Used to search for keywords in the experiment display list.
- 2. Clear:** Clears the keyword search.
- 3. Experiment display list:** Displays the experiments in a list.
- 4. Select:** Selects an experiment.
- 5. Close:** Closes the Select Experiment Profile window.

Figure B.3 Print and Export Preview Window



1. **Print:** Prints the report.
2. **Export to PDF or CSV:** Exports the report as a PDF or CSV file.
3. **Report view:** Displays the detailed report view.

## System Operation Log

The System Operation Log generates system log records for settings, configuration, maintenance, and QC.

Select **Log > System Operation Log** to open the System Operation Log window. Refer to [Figure B.4](#).

Figure B.4 System Operation Log Window

#	Operation	Username	User Full Name	Timestamp	Record
1	Modify Sample Injection M...	Admin	Administrator	2016-10-24 09:55:34	Modify sample injection mode from plate loader mode to semi automation mode.
2	Modify Laser Settings	TechSupport	TechSupport	2016-10-24 11:28:27	Modified laser settings.
3	Modify Laser Settings	TechSupport	TechSupport	2016-10-24 11:29:22	Modified laser settings.
4	Modify Sample Injection M...	Admin	Administrator	2016-10-24 11:28:38	Modify sample injection mode from semi automation mode to manual mode.
5	Import QC Target File	Admin	Administrator	2016-10-24 15:28:55	Import QC target file C:\BAHQ\log, lot No.: BAH02.
6	Run QC	Admin	Administrator	2016-10-24 15:31:36	Run QC, lot No.: BAH02.
7	Run QC	Admin	Administrator	2016-10-24 15:32:29	Run QC, lot No.: BAH02.
8	Run QC	Admin	Administrator	2016-10-24 15:33:05	Run QC, lot No.: BAH02.
9	Modify Sample Injection M...	Admin	Administrator	2016-10-24 15:35:42	Modify sample injection mode from manual mode to semi automation mode.
10	Run QC	Admin	Administrator	2016-10-24 15:40:01	Run QC, lot No.: BAH02.
11	Run QC	Admin	Administrator	2016-10-24 15:44:10	Run QC, lot No.: BAH02.
12	Run QC	Admin	Administrator	2016-10-24 16:00:00	Run QC, lot No.: BAH02.
13	Delete QC Result	Admin	Administrator	2016-10-24 16:11:44	Delete QC result, lot No.: BAH02, date: 2016-10-24.
14	Run QC	Admin	Administrator	2016-10-25 08:28:01	Run QC, lot No.: BAH02.
15	Run QC	Admin	Administrator	2016-10-27 08:57:21	Run QC, lot No.: BAH02.
16	Run QC	Admin	Administrator	2016-10-27 09:00:44	Run QC, lot No.: BAH02.
17	Run QC	Admin	Administrator	2016-10-27 09:10:54	Run QC, lot No.: BAH02.
18	Run QC	Admin	Administrator	2016-10-27 09:18:44	Run QC, lot No.: BAH02.
19	Delete QC Result	Admin	Administrator	2016-10-27 09:20:41	Delete QC result, lot No.: BAH02, date: 2016-10-17.

**NOTE** The System Operation Log uses the same query criteria and functions as the Experiment Operation Log. Refer to [Figure B.1](#).

## User Management Operation Log

The User Management Operation Log generates audit log records for user management, role management, account policies, password changes, and login/logout records.

Select **Log > User Management Operation Log** to open the User Management Operation Log window. Refer to [Figure B.5](#).

**Figure B.5** User Management Operation Log Window

Operation	Username	User Full Name	Timestamp	Record
1 Login	Admin	Administrator	2016-11-04 10:03:40	Login successfully.
2 Change password	Admin	Administrator	2016-11-04 10:03:00	Change password.
3 Logout	Admin	Administrator	2016-11-04 10:03:00	Logout.
4 Login	Admin	Administrator	2016-11-04 10:41:00	Login failed (Username: Admin).
5 Login	Admin	Administrator	2016-11-04 10:41:13	Login successfully.
6 Logout	Admin	Administrator	2016-11-04 10:42:42	Logout.
7 Login	Admin	Administrator	2016-11-04 10:44:00	Login successfully.
8 Login	Admin	Administrator	2016-11-04 10:46:40	Login successfully.
9 Logout	Admin	Administrator	2016-11-04 11:07:20	Logout.
10 Login	Admin	Administrator	2016-11-07 09:03:10	Login successfully.
11 Logout	Admin	Administrator	2016-11-08 11:00:07	Logout.
12 Login	Admin	Administrator	2016-11-08 11:00:11	Login failed (Username: Admin).
13 Login	Admin	Administrator	2016-11-08 11:00:14	Login successfully.
14 Logout	Admin	Administrator	2016-11-08 10:01:42	Logout.
15 Login	Admin	Administrator	2016-11-08 11:00:52	Login failed (Username: Admin).
16 Login	Admin	Administrator	2016-11-08 11:01:01	Login successfully.
17 Create user	Admin	Administrator	2016-11-08 07:07:02	Create new user (Username: Sarah, Full Name: Sarah L. Rolland-Operatic, Enabled: Yes).
18 Modify user information	Admin	Administrator	2016-11-08 07:08:02	Modify user usability (Username: Sarah from [Yes] to [No]).
19 Modify user information	Admin	Administrator	2016-11-08 07:08:00	Modify user usability (Username: Sarah from [No] to [Yes]).
20 Reset password	Admin	Administrator	2016-11-08 07:07:00	Reset password for user (Username: Sarah).
21 Create role	Admin	Administrator	2016-11-08 06:16:12	Create new role (Role Name: Quality Control, Description: Test, Assigned).

**NOTE** The User Management Operation Log uses the same query criteria and functions as the Experiment Operation Log. Refer to [Figure B.1](#).

## Electronic Signature

### Signing Experiments

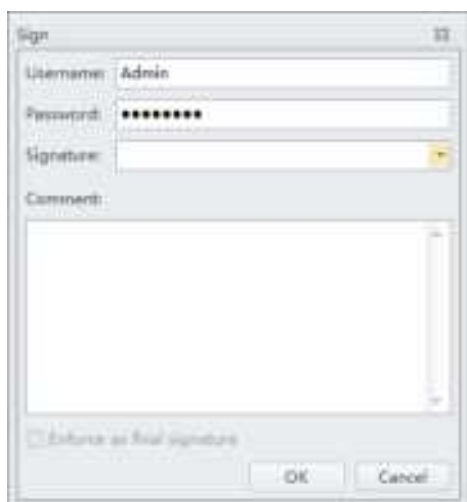
- 1 Select **File > Save** to save the experiment.

- 2 Select **Signature > Sign**. The Sign window appears.



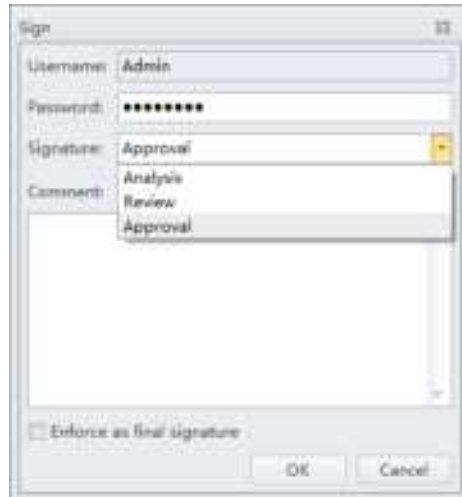
The screenshot shows a dialog box titled "Sign". It has a "Username" field with the text "Admin" entered. Below it is a "Password" field which is currently empty. Underneath the password field is a "Comment" label followed by a large, empty text area. At the bottom of the dialog box are two buttons: "OK" and "Cancel".

- 3 Enter your user name and password.



The screenshot shows the same "Sign" dialog box. The "Username" field still contains "Admin". The "Password" field now contains eight asterisks. A new "Signature" field has appeared below the password field, and it is currently empty. The "Comment" field remains empty. At the bottom of the dialog box, there is a checkbox labeled "Enforce as final signature" which is currently unchecked. The "OK" and "Cancel" buttons are still present.

- 4 Select the appropriate signature.



**NOTE** Only the highest signature level can skip to the final approval by selecting **Enforce as the final signature**.

- 5 If necessary, enter comments related to the experiment.

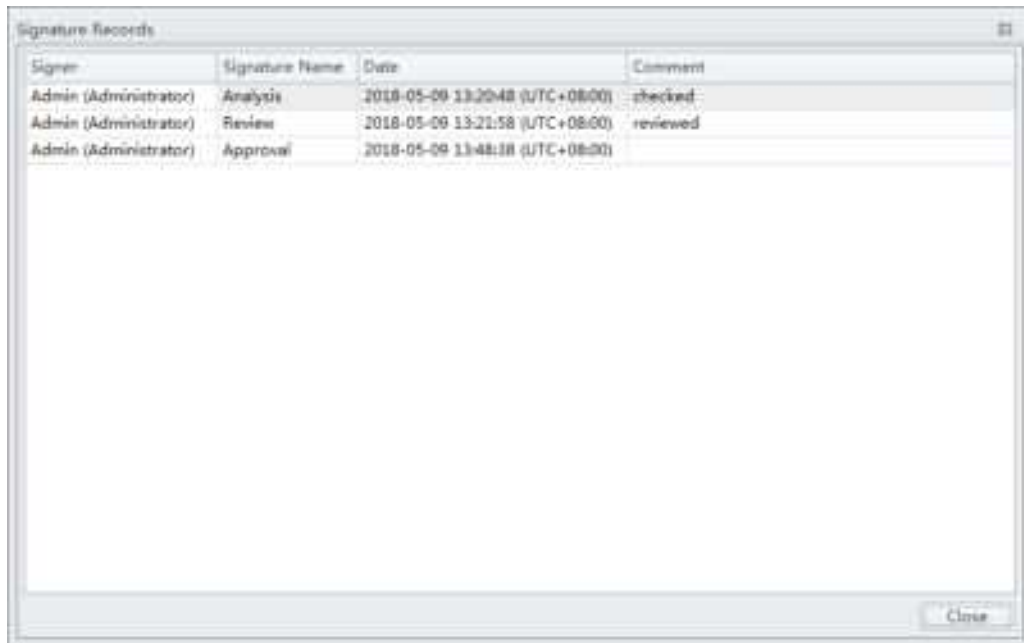
- 6 Select **OK**.

The signature status displays in the top-left corner of the software screen.



If the experiment has been signed by all required signatures or the **Enforce as final signature** is selected, the status displays: *The experiment has been validated.*

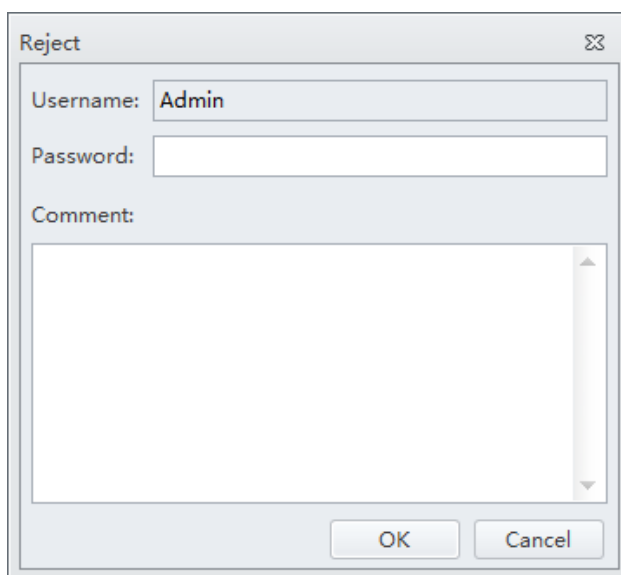
- 7 Select **Signature > Signature Records** to view the electronic signature details.



Signer	Signature Name	Date	Comment
Admin (Administrator)	Analysis	2018-05-09 13:20:48 (UTC+08:00)	checked
Admin (Administrator)	Review	2018-05-09 13:21:58 (UTC+08:00)	reviewed
Admin (Administrator)	Approval	2018-05-09 13:48:18 (UTC+08:00)	

## Rejecting Experiment

- 1 Select **Signature > Reject**.



Reject

Username:

Password:

Comment:

OK Cancel

**NOTE** You cannot reject an experiment if it has been validated.

- 2 If necessary, enter comments related to the experiment.
- 3 Select **OK**. The following message appears: *Are you sure you want to reject the signature?*
- 4 Select **Yes** to confirm the rejection of your signature or **No** to cancel.

## Setting the Signature Retention Period

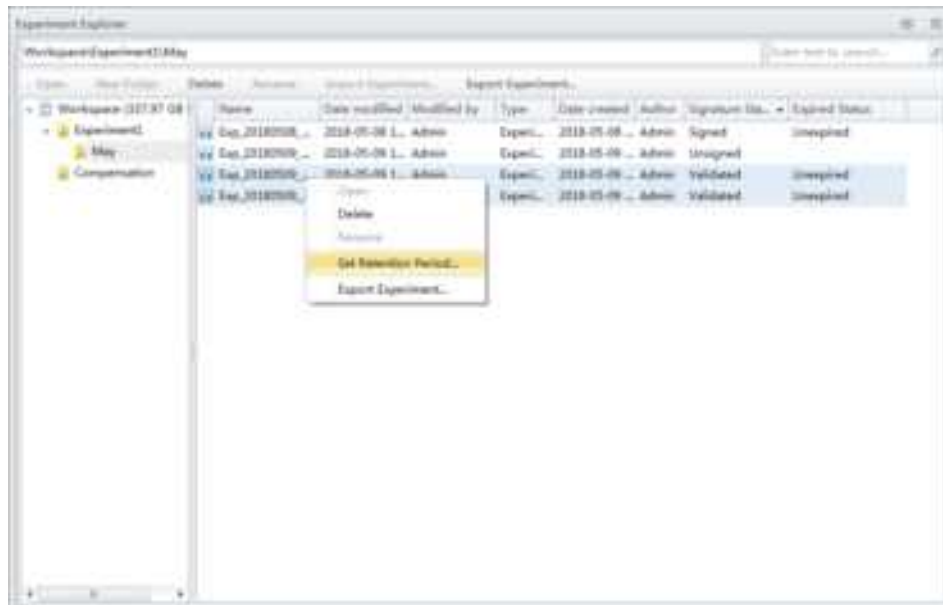
The signature retention period becomes effective immediately once an experiment has been signed. The experiment cannot be deleted or edited within the retention period.

Select **Settings > Set Retention Period** to set the signature retention period for an experiment.



**NOTE** The default signature retention period is 300 days. The allowable range is 1-9999 days.

Select **Settings > Set Retention Period** to navigate to the Experiment Explorer window to set the signature retention period for multiple experiments.



Select **Settings > Retention Period Options** to default signature retention period for experiments.

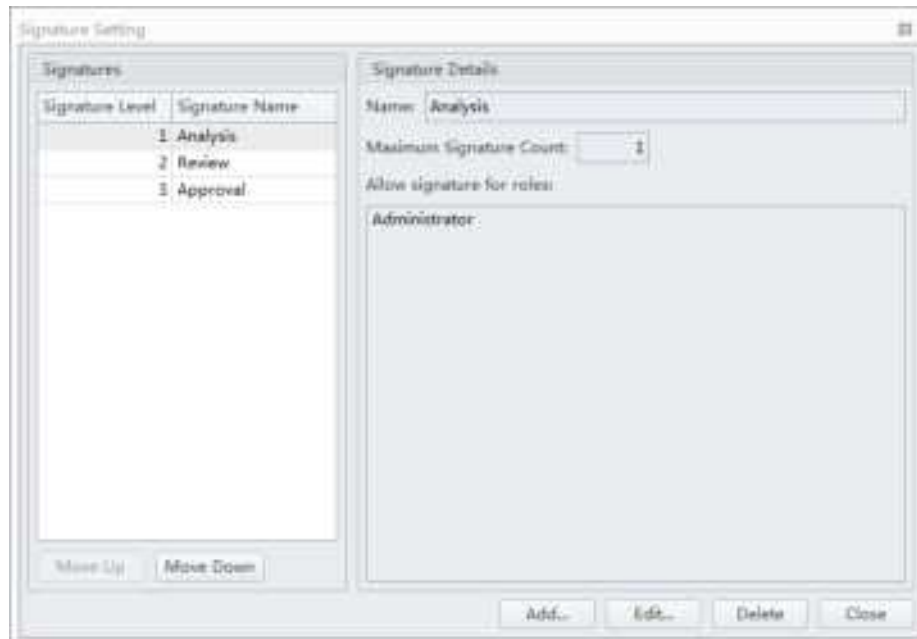


**NOTE** Select **Allow retention period modification for a validated experiment** to allow modifying the signature retention period for a validated experiment.

## Signature Setting

The Signature Setting allows you to set the signature hierarchy, the signature name, and the maximum signature count for each signature level.

**1** Select **Signature > Signature Setting**. The Signature Setting window appears.



**NOTE** You can add a maximum of 3 signature levels.

- 2 Select the signature name to be edited from the Signatures section of the Signature Setting window. Then, select **Edit**. The Edit Signature window appears.



- 3 Enter the signature name.

- 4 Select the desired Maximum Signature Count.

**NOTE** The signature count means the allowable number of signatures for the signature name. You can choose between 1 and 10. The default value is 1.

- 5 Select a role for the signature from the *Allow signature for roles* section of the Edit Signature window.



**NOTE** Each role can sign or reject only if the sign/reject permission is assigned and the role signature is selected. The available roles displayed in the window depend on the permission setting assigned in Role Manager. To assign sign/reject permissions to a role, refer to [CHAPTER 2, Modifying User Roles in the Role Window](#).

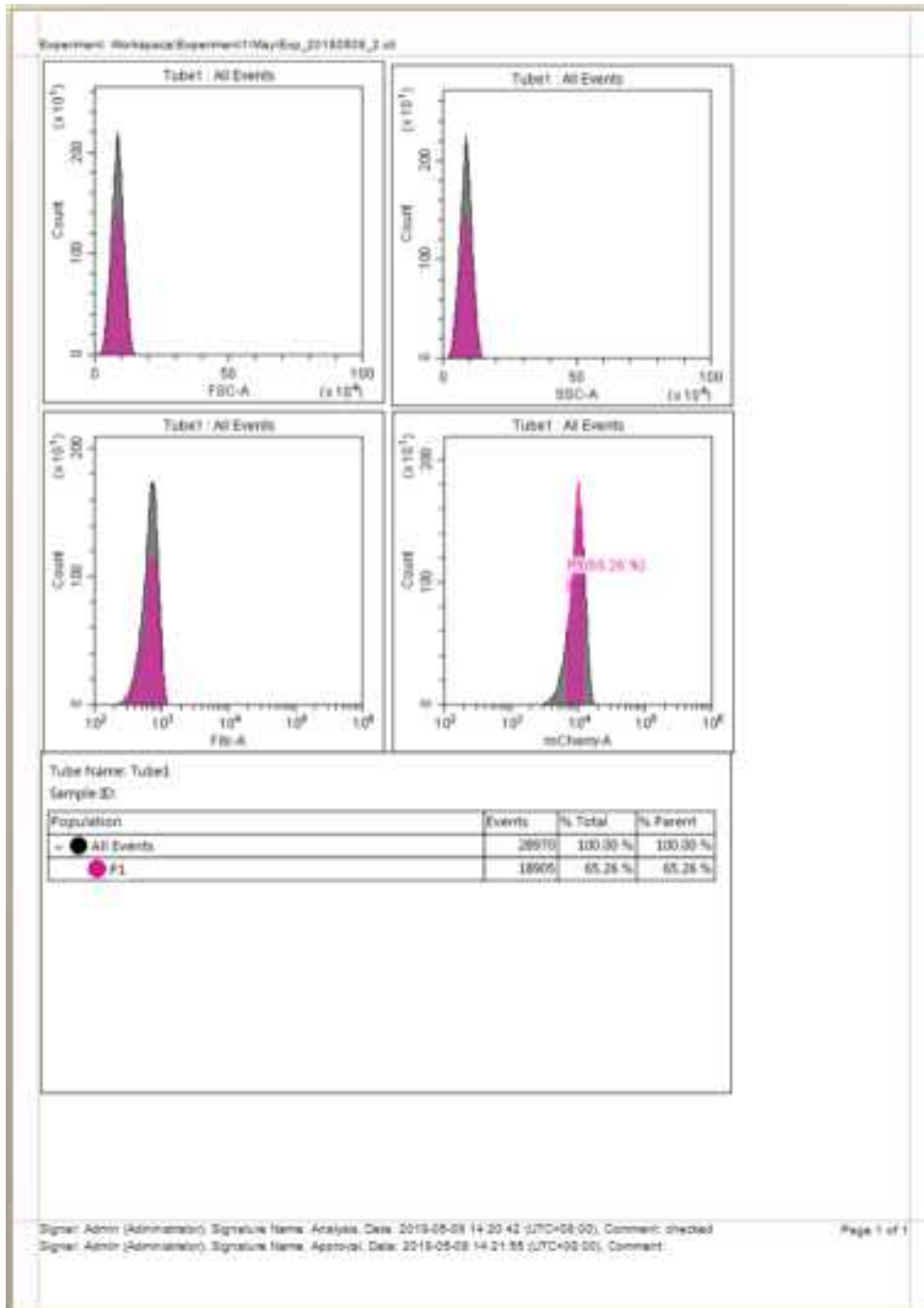
- 6 Select **OK**.

- 7 Select **Close**.

## Printing an Experiment Signature

**IMPORTANT** Ensure an experiment is signed prior to attempting to print the experiment signature.

To print an experiment with a signature, refer to [Printing Graphics](#) in [CHAPTER 6, Data Acquisition and Sample Analysis](#).



## User Management

---

### User Administration

#### Logging In and Out of the Software

Refer to [Logging into the Software](#) and [Logging Out of the Software](#) in [CHAPTER 4, Daily Startup](#).

#### Locking the Account

Refer to [Locking the Account](#) in [CHAPTER 4, Daily Startup](#).

#### Role Management

Refer to [Role Management](#) in [CHAPTER 2, Using the CytExpert Software](#).

#### User Management

Refer to [User Management](#) in [CHAPTER 2, Using the CytExpert Software](#).

#### Account Policies

Refer to [Account Policies](#) in [CHAPTER 2, Using the CytExpert Software](#).

# Sample Injection Mode Control Kit

## Overview

The Sample Injection Mode Control Kit is a mechanical knob installed by your service engineer that enables users to switch between the Plate Loader sample injection mode and the Semi-Automatic or manual sample injection mode. The switch eliminates the need to manually re-route the tubing.

This chapter contains information on:

- [Performance Characteristics \[With the Sample Injection Mode Control Knob\]](#)
- [Sample Injection Mode Control Kit Components](#)
- [Switching the Sample Probe from the Single Tube Sample Station to the Plate Loader \[With Sample Injection Mode Control Knob\]](#)
- [Switching the Sample Probe from the Plate Loader to the Single Tube Sample Station \[With Sample Injection Mode Control Knob\]](#)

## Performance Characteristics [With the Sample Injection Mode Control Knob]

Performance [CytoFLEX or CytoFLEX S With Standard Plate Loader]	
Throughput [With Standard Plate Loader] <sup>a</sup>	10 second acquisition without mixing or backflush: <35 min.
	10 second acquisition with 3 second mixing and 4 second backflush: <50 min.

- a. This performance characteristic is different if you do not have the Sample Injection Mode Control Kit installed on your CytoFLEX flow cytometer. Refer to [CHAPTER 1, Performance Characteristics](#).

Performance [CytoFLEX or CytoFLEX S With Plate Loader DW]		
Carryover	Plate Loader format	≤1.0%
Throughput [With Plate Loader DW] <sup>a</sup>	Standard 96-well plate, 10 second acquisition without mixing or backflush:	<36 min.
	96-well deep well plate, 10 second acquisition without mixing or backflush:	<37 min.
	Standard 96-well plate, 10 second acquisition with 5 second mixing and 4 second backflush:	<54 min.
	96-well deep well plate, 10 second acquisition with 10 second mixing and 4 second backflush:	<64 min.

- a. The Plate Loader DW is equipped with the Sample Injection Mode Control Kit. Refer to [APPENDIX C, Sample Injection Mode Control Kit](#).

Performance [CytoFLEX LX With Standard Plate Loader]	
Throughput [With Standard Plate Loader] <sup>a</sup>	10 second acquisition without mixing or backflush: <38 min.
	10 second acquisition with 3 second mixing and 6 second backflush: < 56 min.

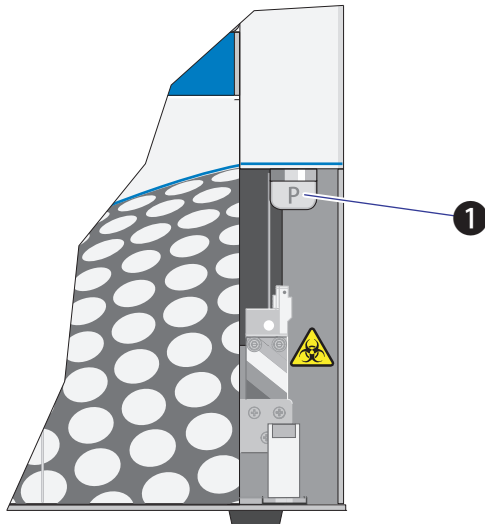
a. This performance characteristic is different if you do not have the Sample Injection Mode Control Kit installed on your CytoFLEX LX flow cytometer. Refer to [CHAPTER 1, Performance Characteristics](#).

Performance [CytoFLEX LX With Plate Loader DW]		
Carryover	Plate Loader format	≤1.0%
Throughput [With Plate Loader DW] <sup>a</sup>	Standard 96-well plate, 10 second acquisition without mixing or backflush:	<39 min.
	96-well deep-well plate, 10 second acquisition without mixing or backflush:	<40 min.
	Standard 96-well plate, 5 second acquisition with 6 second mixing and 4 second backflush:	<60 min.
	96-well deep well plate, 10 second acquisition with 6 second mixing and 4 second backflush:	<69 min.

a. The Plate Loader DW is equipped with the Sample Injection Mode Control Kit. Refer to [APPENDIX C, Sample Injection Mode Control Kit](#).

## Sample Injection Mode Control Kit Components

Figure C.1 Sample Injection Mode Control Knob



1. Switch module knob

**NOTE** The **P** indicates the instrument is set to Plate Loader sample injection mode. The **T** indicates the instrument is set to the Semi-Automatic or manual sample injection mode.

## Switching the Sample Probe from the Single Tube Sample Station to the Plate Loader [With Sample Injection Mode Control Knob]

---



### WARNING

Risk of biohazardous contamination if you have skin contact with the sample probe or the sample peristaltic pump tubing. The sample probe and the sample peristaltic pump tubing could contain residual biological material and must be handled with care. Clean up spills immediately.

Use universal precautions when working with pathogenic materials. Means must be available to decontaminate the instrument and to dispose of biohazardous waste.

### WARNING

Risk of biohazardous contamination and/or sample dilution when performing a manual backflush. If the CytExpert Sample Injection Mode does not match the Sample Injection Control Knob position, a manual backflush can cause backflush fluid to flow through the path set by the Sample Injection Mode Control knob potentially contaminating the sample tube/plate and/or the sample station. Ensure the Sample Injection Mode Control Knob is positioned to match the correct CytExpert Sample Injection Mode. Clean up spills immediately.

Use universal precautions when working with pathogenic materials. Means must be available to decontaminate the instrument and to dispose of biohazardous waste.

### CAUTION

Risk of instrument damage. The sample probe can easily become damaged or deformed. To avoid damage to the sample probe, turn the switch module knob carefully and avoid contacting the sample probe.

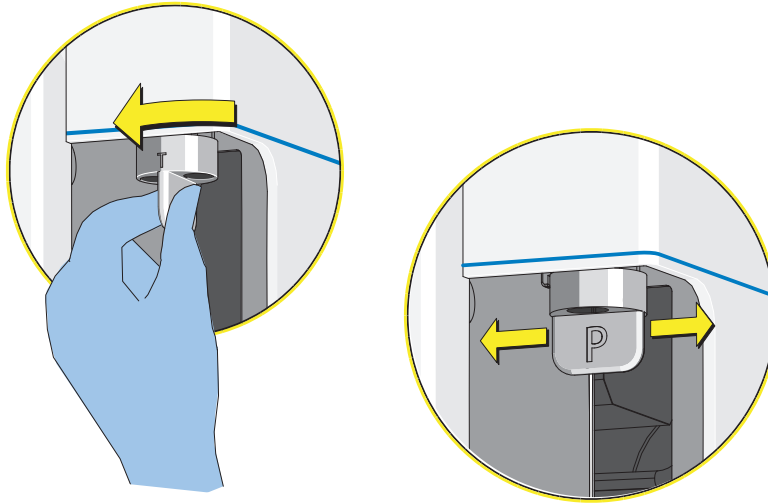
**NOTE** If you do not have the Sample Injection Mode Control Kit installed, refer to [CHAPTER 12, Changing the Sample Probe from the Single Tube Sample Station to the Plate Loader \[CytoFLEX With Plate Loader\]](#).

- 1 Switch to the Plate Loader sample injection mode. Refer to [CHAPTER 4, Selecting the Plate Loader Sample Injection Mode \[With Plate Loader\]](#).

## Sample Injection Mode Control Kit

Switching the Sample Probe from the Single Tube Sample Station to the Plate Loader [With Sample Injection Mode Control Knob]

- 2 Turn the switch module knob to the left until the flat side of the knob is parallel to the front panel and the **P** is facing you. Ensure that the knob is turned as far as it will go.



The system is now ready for use in the Plate Loader sample injection mode.

**NOTE** If you do not see any events upon running an acquisition:

1. Select  to stop the acquisition.
2. Ensure that the switch module knob is turned as far as it will go.
3. Rerun the acquisition.
4. If the problem persists, [contact us](#).

## Switching the Sample Probe from the Plate Loader to the Single Tube Sample Station [With Sample Injection Mode Control Knob]

---



### WARNING

Risk of biohazardous contamination if you have skin contact with the sample probe or the sample peristaltic pump tubing. The sample probe and the sample peristaltic pump tubing could contain residual biological material and must be handled with care. Clean up spills immediately.

Use universal precautions when working with pathogenic materials. Means must be available to decontaminate the instrument and to dispose of biohazardous waste.

### WARNING

Risk of biohazardous contamination and/or sample dilution when performing a manual backflush. If the CytExpert Sample Injection Mode does not match the Sample Injection Control Knob position, a manual backflush can cause backflush fluid to flow through the path set by the Sample Injection Mode Control knob potentially contaminating the sample tube/plate and/or the sample station. Ensure the Sample Injection Mode Control Knob is positioned to match the correct CytExpert Sample Injection Mode. Clean up spills immediately.

Use universal precautions when working with pathogenic materials. Means must be available to decontaminate the instrument and to dispose of biohazardous waste.

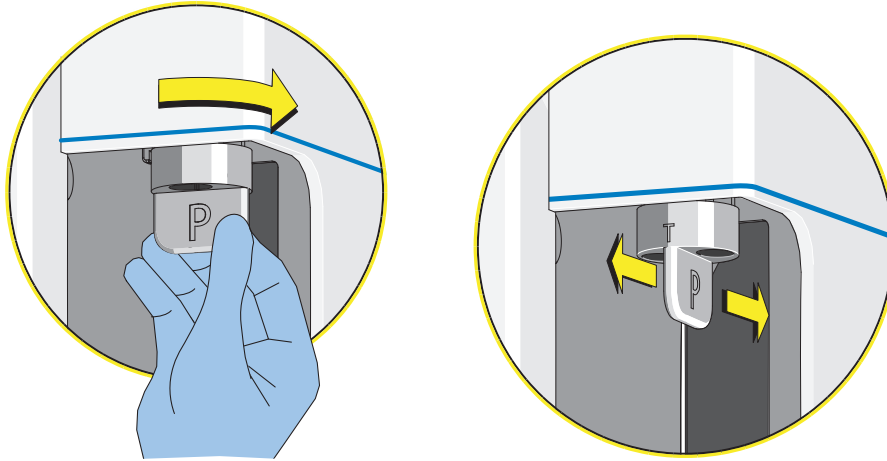
### CAUTION

Risk of instrument damage. The sample probe can easily become damaged or deformed. To avoid damage to the sample probe, turn the switch module knob carefully and avoid contacting the sample probe.

**NOTE** If you do not have the Sample Injection Mode Control Kit installed, refer to [CHAPTER 12, Changing the Sample Probe from the Plate Loader to the Single Tube Sample Station \[CytoFLEX With Plate Loader\]](#).


- 1 Switch to either the Semi-Automatic or manual sample injection mode. Refer to [CHAPTER 4, Selecting the Proper Sample Injection Mode](#).

- 2 Turn the switch module knob to the right until the flat side of knob is perpendicular to the front panel and the T is facing you. Ensure that the knob is turned as far as it will go.



The system is now ready for use in either the Semi-Automatic or manual sample injection mode.

**NOTE** If you do not see any events upon running an acquisition:

1. Select  to stop the acquisition.
2. Ensure that the switch module knob is turned as far as it will go.
3. Rerun the acquisition.
4. If the problem persists, [contact us](#).

## Specimen Collection Plate Specifications

---

Beckman Coulter does not recommend the use of one plate in preference to another nor guarantee the acceptability of the plates to produce quality results. If you need information on a plate not listed in [Table D.1](#), ensure that the plate size and characteristics conform to the specifications listed below. Calibrate the plate position for any new plate types prior to acquisition. Refer to [CHAPTER 12, Calibrating the Plate Position \[With Plate Loader\]](#).

**Table D.1** Deep Well Plate [with Plate Loader DW]

Name	Volume	Material	Manufacturer	PN
96-well deep well plate	1 mL	Polystyrene	Beckman Coulter	267001
96-well deep well plate	1 mL	Polypropylene	Beckman Coulter	267006
96-well deep well plate	2 mL	Polypropylene	Beckman Coulter	140504

**NOTE** Ensure that the following specifications are met when you select the 96-well deep well plates:

- The inner well diameter is  $\geq 5.8$  mm.
- The plate height is  $\leq 45.5$  mm.



## Overview

---

**IMPORTANT** A custom optical filter could influence the performance of other channels due to the band pass and the reflection efficiency. Beckman Coulter recommends the operator to validate the performance of the custom optical filter within their configuration prior to accepting experimental results.

The optical filter is critical for optimal experiment results. When selecting an optical filter glass piece, the filter should comply with the following specifications.

**Table E.1** CytoFLEX Platform Optical Filter Specifications

Length	14.5 mm $\pm$ 0.1 mm
Width	6.1 mm $\pm$ 0.1 mm
Thickness	2.0 mm $\pm$ 0.1 mm
Incident angle	14 $^{\circ}$ $\pm$ 2 $^{\circ}$
Material	Fused silica, N-BK7, or equivalent
Surface quality	60/40 on both surfaces
Parallelism	$\leq$ 20 arc seconds
Optical density	Make sure the optical density of the optical filter glass is big enough to block the wavelengths of the installed lasers to decrease the background noise.

**NOTE** When installing a custom filter, you need to create a new detector configuration. Refer to [CHAPTER 6, Verifying, Selecting, Editing, and Creating Detector Configuration](#). For QC, refer to [CHAPTER 5, Instrument Quality Control and Standardization](#).

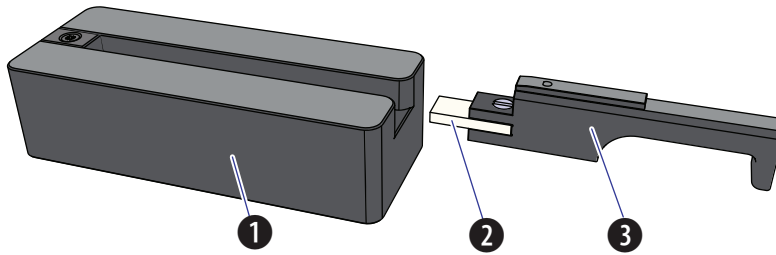
## Installing a Custom Optical Filter

---

**IMPORTANT** Keep the optical filter mounting fixture for future use.

The optical filter mounting fixture is used to align the custom optical filter glass piece with the optical filter holder. The optical filter mounting fixture and the optical filter holder are optional accessories that can be purchased separately.

Figure E.1 Optical Filter Mounting Fixture and Optical Filter



1. Optical filter mounting fixture
2. Custom optical filter glass piece
3. Optical filter holder

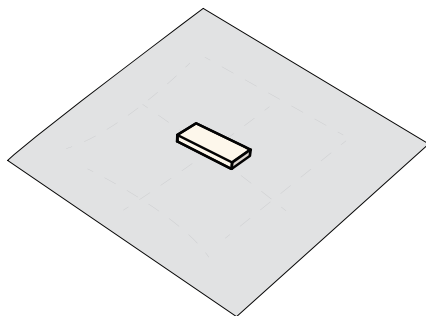
Before you start to install the custom optical filter glass piece, ensure the following items are available:

- Custom optical filter glass piece
- Optical filter mounting fixture
- Optical filter holder
- 3.0 mm flat-head screwdriver
- Lens papers
- Absolute ethanol

**⚠ CAUTION**

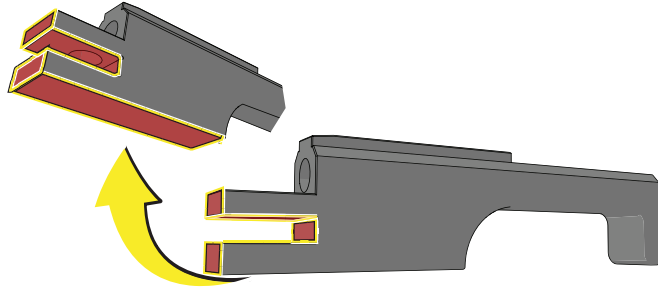
**Risk of damage to the optical filter. When cleaning or replacing a filter, handle with care to avoid scratching the glass surface and to prevent the filter from falling. Use optical lens paper and absolute ethanol to clean the optical filters.**

- 1 Place the new custom optical filter glass piece on a piece of clean lens paper.



- 2 Moisten a piece of lens paper with several drops of absolute ethanol.

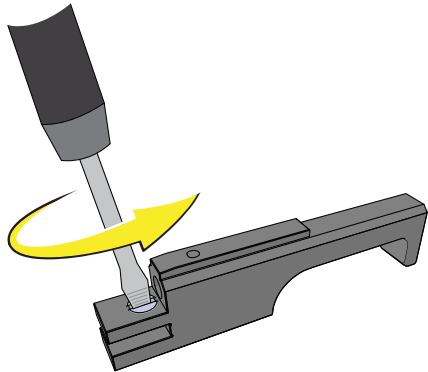
- 
- 3 Using the moistened lens paper gently clean any spots on the surface of the optical filter glass piece and the socket of the optical filter holder.



- 
- 4 Allow the custom optical filter glass piece to dry and check the optical filter glass piece for streaks.

**NOTE** If streaks remain, repeat Steps 2-3 until the custom optical filter glass piece is clean. If the optical filter glass piece is scratched, replace the optical filter glass piece as needed.

- 
- 5 Using the 3.0 mm flat-head screwdriver, loosen the screw on the optical filter holder.



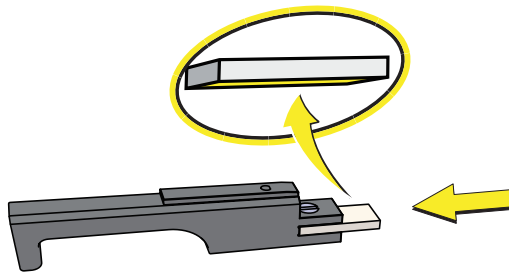
**CAUTION**

Risk of damage to the optical filter glass piece. Push the optical filter glass piece straight into the optical filter holder socket carefully. Inserting the optical filter glass piece at an angle could chip the edge of the optical filter glass piece.

**CAUTION**

Risk of damage to the optical filter glass piece. Do not touch the filter glass piece. Touching the optical filter glass can obscure and/or scratch the optical filter. Always handle the optical filter glass piece with lens paper.

- 6 Push the clean optical filter glass piece straight into the optical filter holder socket with the band pass coating surface facing down.



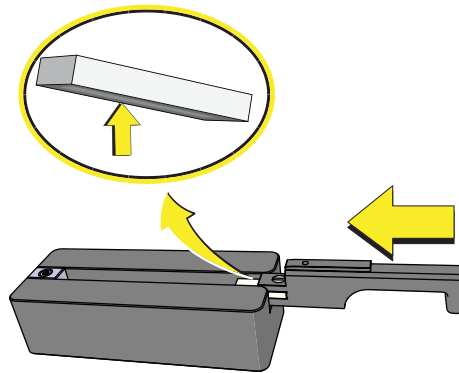
**NOTE** If you are unsure about which surface is the band pass coating surface, consult the supplier of your custom filter glass piece.

- 7 Using the 3.0 mm flat-head screwdriver, fasten the screw on the filter holder. Do not fully tighten the screw until adjustments are completed below.

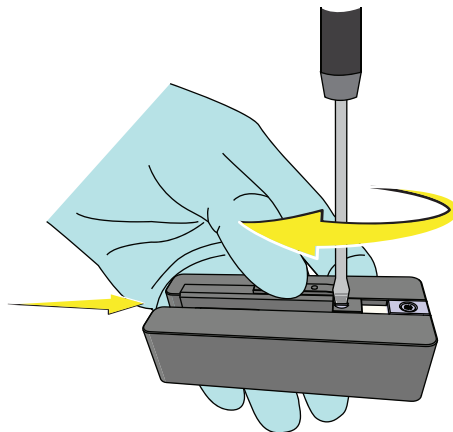
**⚠ CAUTION**

**Risk of damage to the optical filter. Push the filter all the way into the mounting fixture carefully. Inserting the filter at an angle could chip the edge of the filter glass piece.**

- 8 Slide the optical filter into the slot of the optical filter mounting fixture until it touches the end of the fixture.



- 9 Hold the optical filter and tighten the screw using the 3-mm flat-head screwdriver.



- 10 If necessary, label the optical filter holder with the corresponding band pass information.

- 11 Install the optical filter into the WDM. Refer to [CHAPTER 12, Replacing the Optical Filter](#).

- 12 Edit the detector configuration to ensure the correct display of axis labels. Refer to [CHAPTER 6, Verifying, Selecting, Editing, and Creating Detector Configuration](#).

---

**13** Run QC to check whether the custom filter has impacted the performance of the default channels. Refer to [CHAPTER 5, Instrument Quality Control and Standardization](#).

**NOTE** QC will not provide a result for laser-filter combinations that do not have a target value.

---

**14** If necessary, you need to adjust the filter screw slightly and repeat QC until optimal performance is achieved. Refer to Step 9 and Steps 11-13.

---

# APPENDIX F

## WDM Beam Splitter

### Overview

---

**IMPORTANT** This chapter applies to CytoFLEX LX instruments with the WDM beam splitter installed. The WDM beam splitter is installed by your Beckman Coulter Service Representative. The instrument configuration must have the IR laser and WDM activated to use the WDM beam splitter.

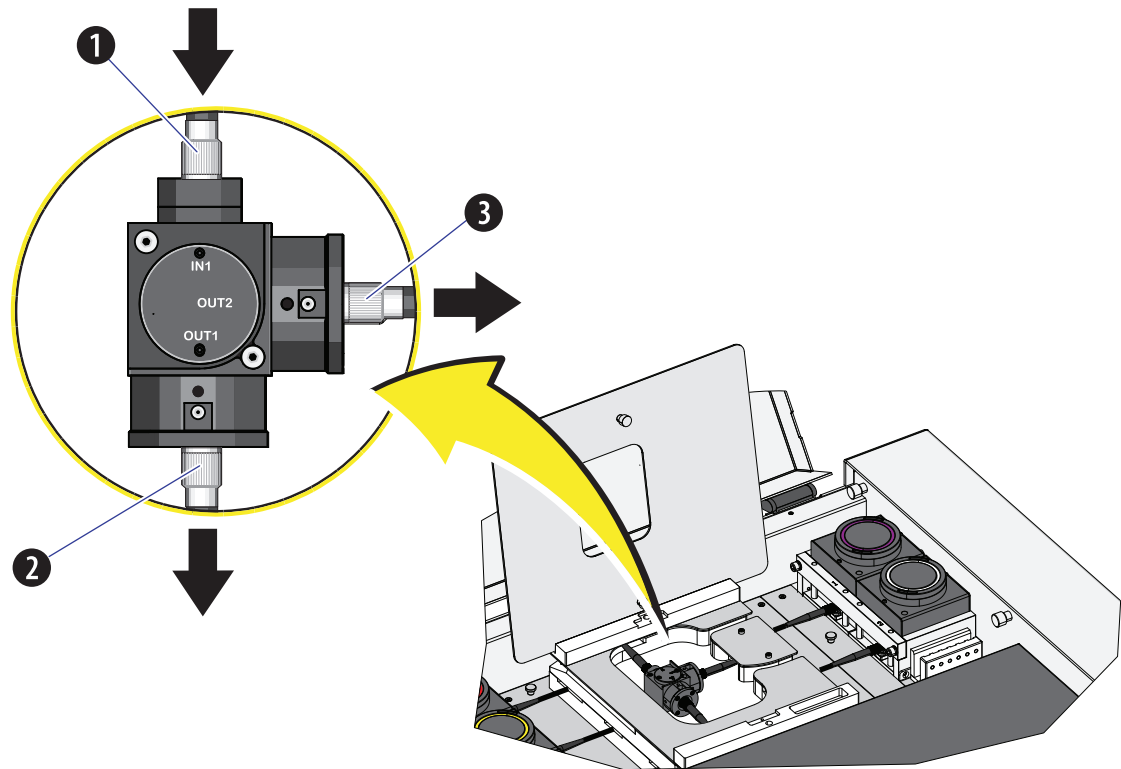
The WDM beam splitter splits the light from the UV, Near UV or Violet laser into the original WDM and the Infrared WDM. This results in the following new channels:

- V(S)712 for the Violet laser line
- N(S)740 and N(S)819 for the Near UV laser line
- U(S)740 and U(S)819 for UV laser lines.

Refer to [Table 1.7](#).

**NOTE** The labels on the beam splitter ports indicate the direction that the fluorescence is transmitted. Refer to [Figure F.1](#).

Figure F.1 WDM Beam Splitter



1. Fiber inlet: Connects to either violet, UV or NUV laser.
2. Beam outlet 1: Transfers the light with wavelength longer than 695 nm to the IR WDM.
3. Beam outlet 2: Transfers the light with wavelength shorter than 695 nm back to the original WDM.

**Table F.1** Configuration Comparison

WDM		Fluorescent Channel (Standard)	Fluorescent Channel (WDM Beam Splitter)
355 nm	355 nm	405/30 BP	405/30 BP
		525/40 BP	525/40 BP
		675/30 BP	675/30 BP
	808 nm	840/20 BP	740/35 BP
		885/40 BP	819/44 BP
375 nm	375 nm	450/45 BP	450/45 BP
		525/40 BP	525/40 BP
		675/30 BP	675/30 BP
	808 nm	840/20 BP	740/35 BP
		885/40 BP	819/44 BP
405 nm	405 nm	405/10 BP <sup>a</sup>	885/40 BP <sup>b</sup>
		450/45 BP	405/10 BP (VSSC)
		525/40 BP	450/45 BP
		610/20 BP	525/40 BP
		660/10 BP	610/20 BP
		763/43 BP	660/10 BP
	808 nm	840/20 BP	712/25 BP
		885/40 BP	763/43 BP

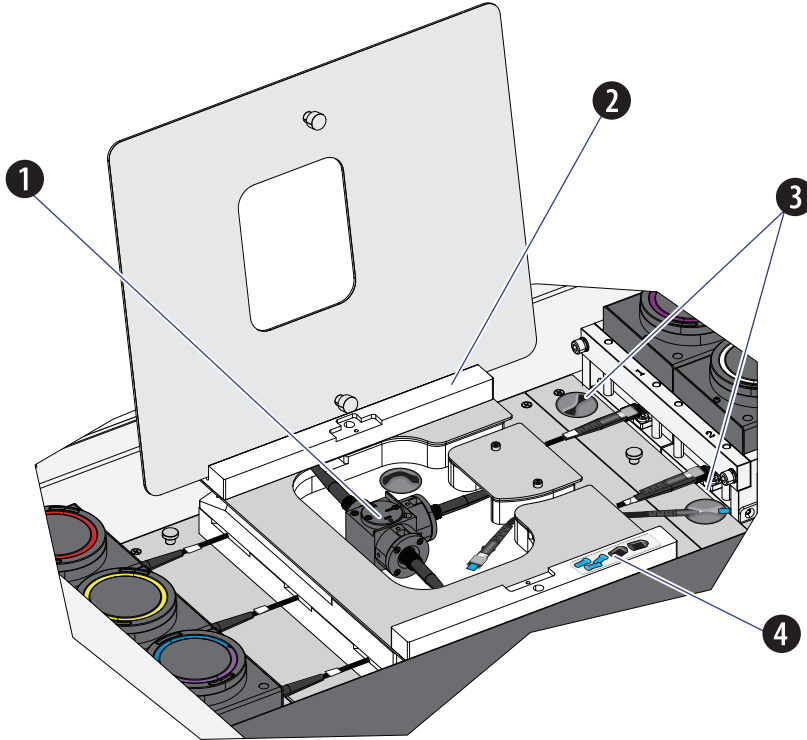
a. This channel has no detector.

b. This channel has no detector.

**NOTE** The 712/25 BP filter, the 740/35 BP filter, and the 819/44 BP filter are supplied in the WDM beam splitter package.

## Modifying Detector Configuration [With WDM Beam Splitter]

Figure F.2 CytoFLEX LX with the WDM Beam Splitter



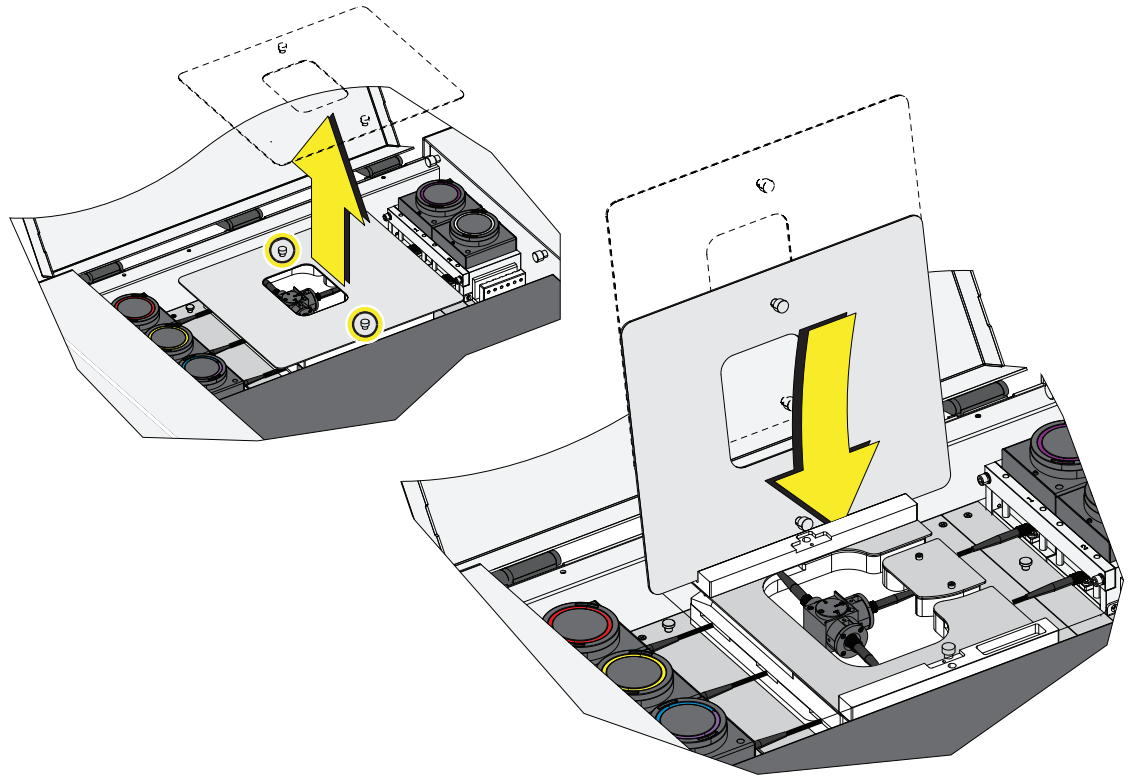
1. WDM beam splitter
2. Cover holder
3. Clips for idle fibers
4. Holder for idle fiber caps

Table F.2 Optical Fibers with Indicator

Optical Fibers	Indicator	Name
	1	Long violet fiber
	2	Long UV/NUV fiber
	3	Red fiber
	4	Yellow fiber
	5	Blue fiber
	6	Long IR fiber
	Violet color ring	Short violet fiber
	White color ring	Short UV/NUV fiber
	Red color ring	Short IR fiber

**NOTE** The short IR fiber, short violet fiber, and the short UV/NUV fibers are delivered with the WDM beam splitter package.

- 1 Open the top cover of the instrument.
- 2 Loosen the two thumbscrews securing the beam splitter cover and put the cover in the cover holder.



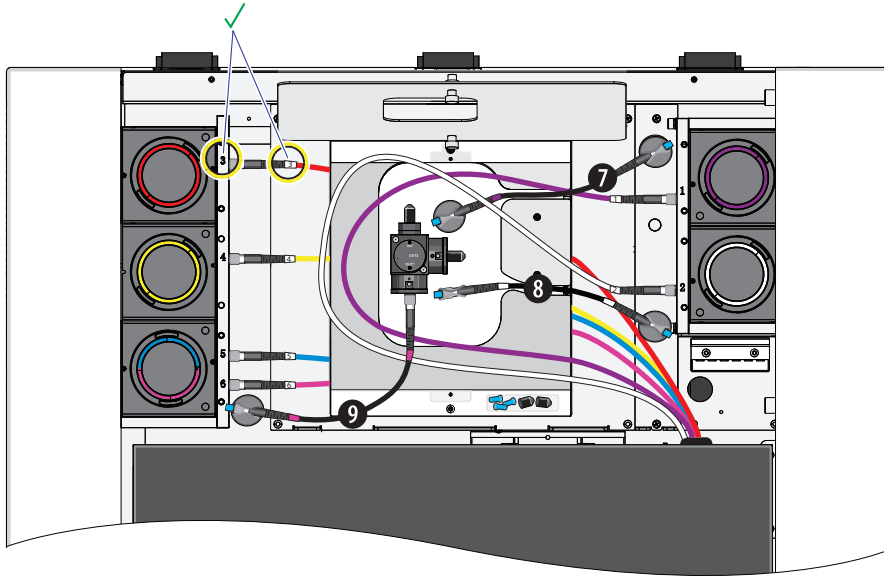
**CAUTION**

Risk of data integrity damage.

- During use, verify that the optical fibers are securely connected to the WDM. A loose connection can alter the optical path and affect fluorescence.
- Do not kink the optical fibers.

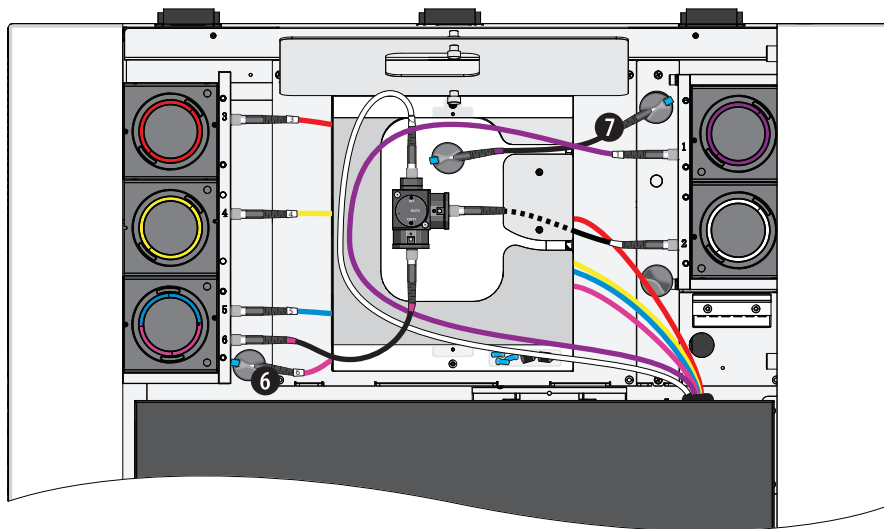
- 3 Connect the correct optical fibers to the corresponding WDMs as needed. Ensure the indicator number or the color ring of the optical fiber matches the corresponding WDM. Refer to [Table F.2](#).

**[WDM Beam Splitter-Not engaged]**



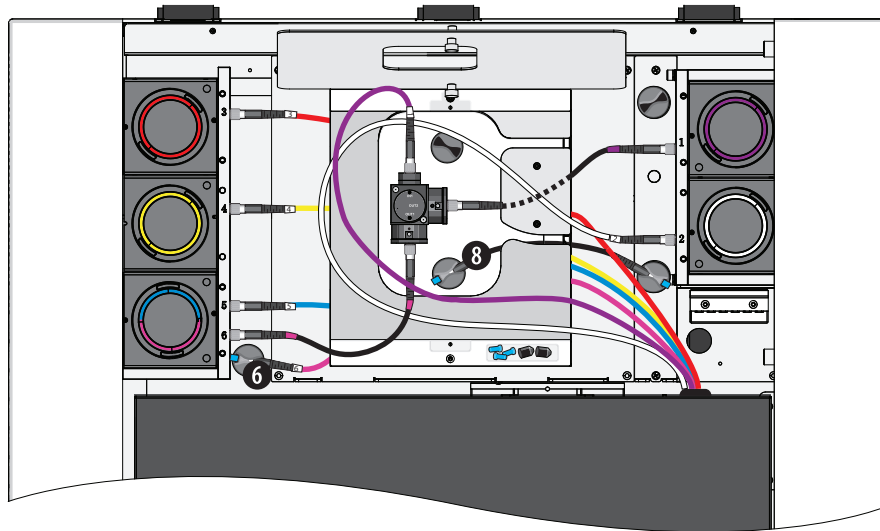
**NOTE** The short IR fiber (9), short violet fiber (7), and the short UV/NUV fiber (8) are idle.

**[UV/NUV Splitter]**



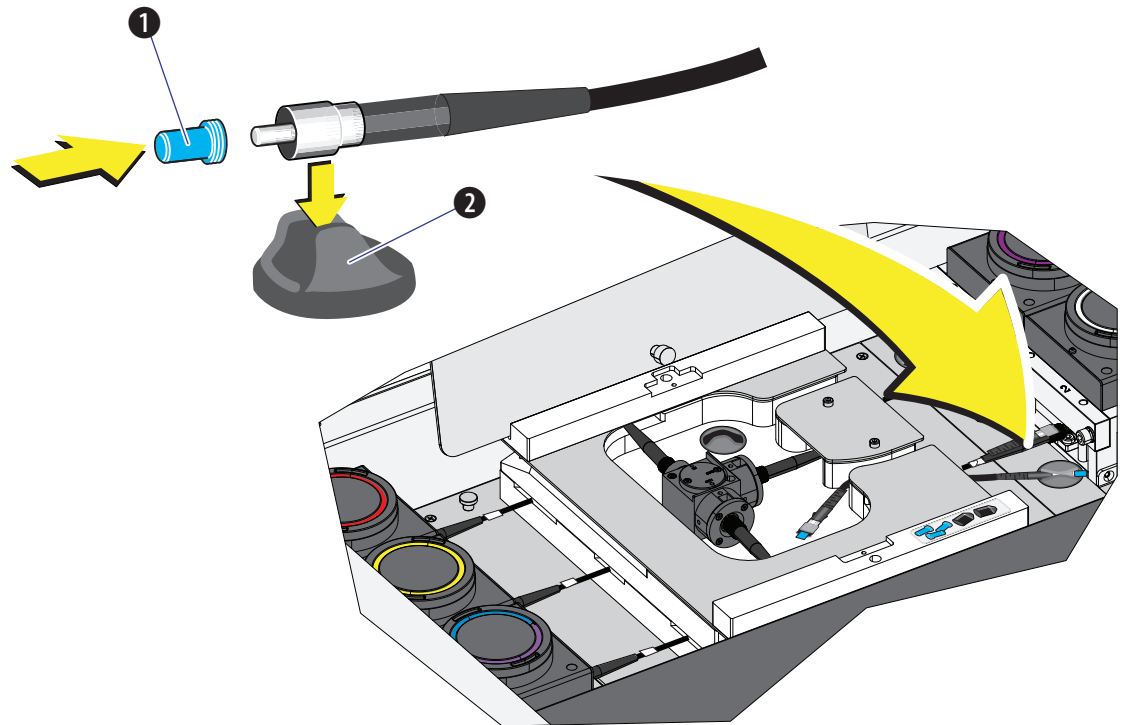
**NOTE** The long IR fiber (6), and the short violet fiber (7) are idle.

[Violet Splitter]



**NOTE** The long IR fiber (6), and the short UV/NUV fiber (8) are idle.

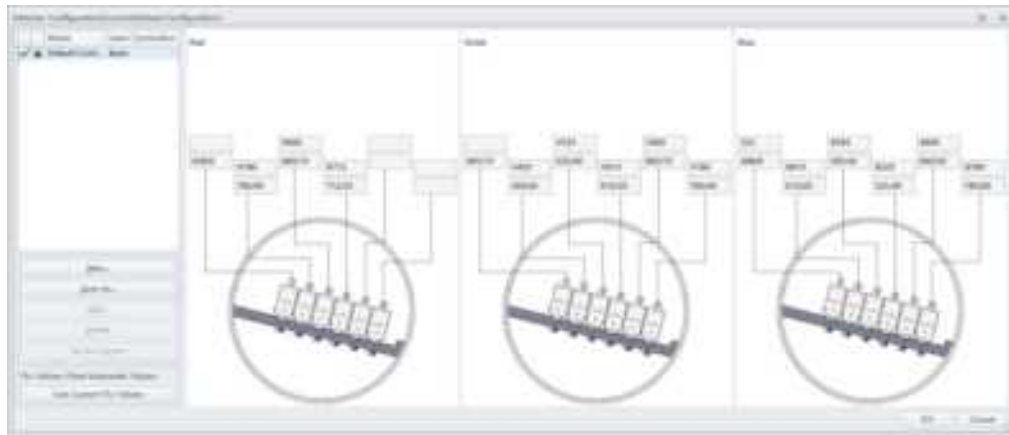
- 4 Put the blue fiber cap (1) on the head of idle fibers and fix the idle fibers in place with the fiber clips (2).



- 
- 5 Change the optical filters in the WDM accordingly. Refer to [Table F.1, Configuration Comparison](#) for the positions of the corresponding optical filters. Refer to [CHAPTER 12, Replacing the Optical Filter](#).

**NOTE** The optical system does not require realignment once the filters are changed.

- 
- 6 Select the proper detector configuration. Refer to [CHAPTER 6, Verifying, Selecting, Editing, and Creating Detector Configuration](#).



- 
- 7 Verify the installed optical filters match the selected detector configuration.

- 
- 8 Run QC. Refer to [CHAPTER 5, Instrument Quality Control and Standardization](#).
-

# Good Practices for Cyber Security

## Overview

---

The following procedures are the only validated and approved recommendations for cyber privacy and security. Contact your IT professional for assistance.

- Changes below require Administrator Level Windows access.
- Before connecting to an external device such as a hard drive, USB, or DVD/CD, verify it does not have a virus or malware.

**NOTE** Beckman Coulter recommends using different anti-virus software to ensure that all viruses or malware can be identified.

- Disable all the unused USB ports on the instrument computer.
- Close all unnecessary applications while operating the CytExpert software.

### CAUTION

**System integrity could be compromised and operational failures could occur if:**

- **This equipment is used in a manner other than specified. Operate the instrument as instructed in the Product Manuals.**
- **You introduce software that is not authorized by Beckman Coulter into your computer. Only operate your system's computer with software authorized by Beckman Coulter.**
- **You install software that is not an original copyrighted version. Only use software that is an original copyrighted version to prevent virus contamination.**

This chapter contains information on:

- [Drive Encryption](#)
- [Protection from Malware Software](#)
- [Operating System Updates](#)
- [System Hardening](#)

## Drive Encryption

---

Your Windows 10 system is equipped with BitLocker. Use BitLocker disk encryption software to prevent unauthorized access to your hard drive, refer to [BitLocker Keys](#). For instructions on BitLocker Encryption or BitLocker Decryption, see [Enabling BitLocker](#) or [BitLocker Decryption](#).

**IMPORTANT** BitLocker is the only approved encryption method.

### BitLocker Keys



**Risk of data loss. Store your BitLocker key in a safe place. For instructions on saving your BitLocker key, refer to [Backing Up Your Recovery Key](#). If you lose your BitLocker Key, you will lose access to your entire hard drive including all of your data. Beckman Coulter is not responsible for security keys and will not be able to recover your data off your hard drive. Work with your IT department in creating and storing the keys in a safe place.**

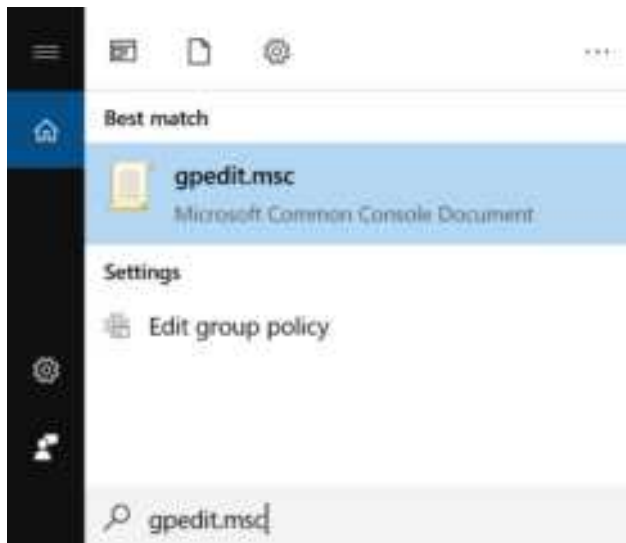
### Changing Encryption Strength Level for BitLocker

BitLocker defaults to XTS-AES 128-bit encryption method. To alter the encryption, follow the steps below before enabling BitLocker. Changes to the encryption level will only impact the encryption of new volumes. Work with your IT department to change the Encryption Strength Level.

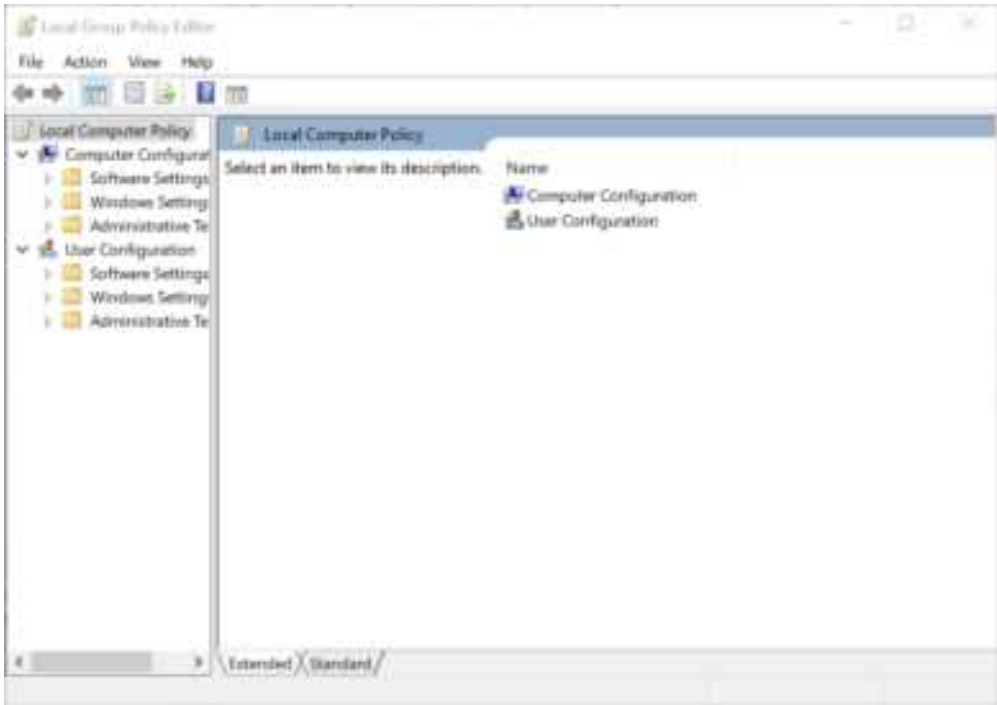
#### Changing the encryption strength for BitLocker

---

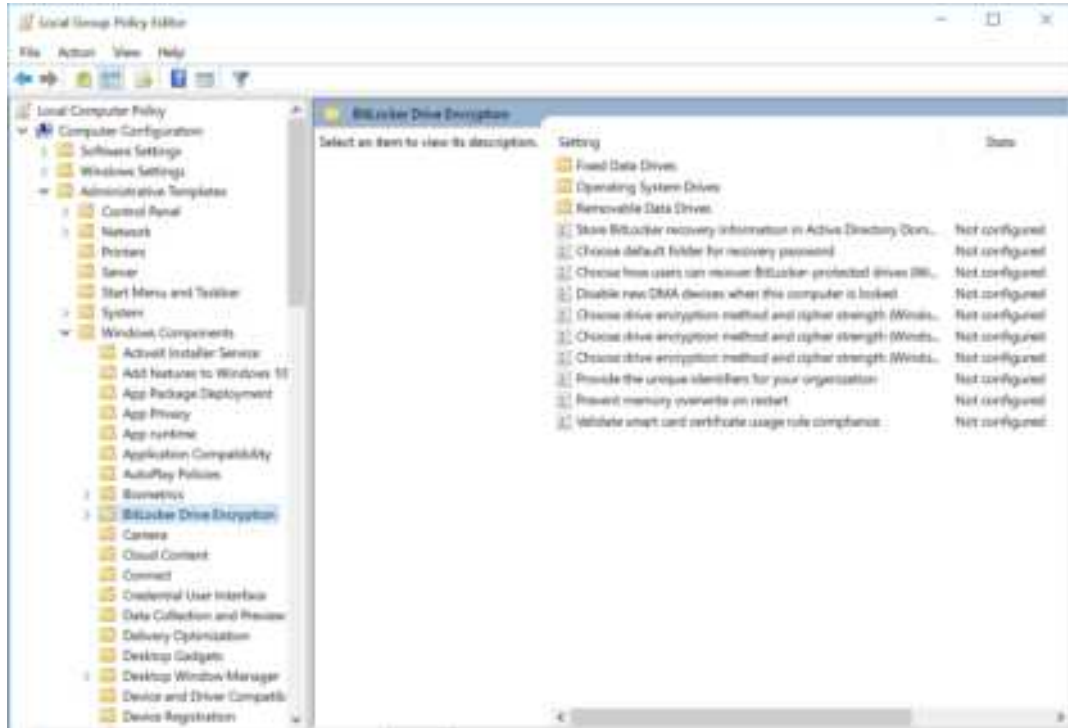
- 1 Type `gpedit.msc` from the Windows search bar to locate the gpedit Control Panel.



2 Click **gpedit.msc**. The Local Group Policy Editor window appears.

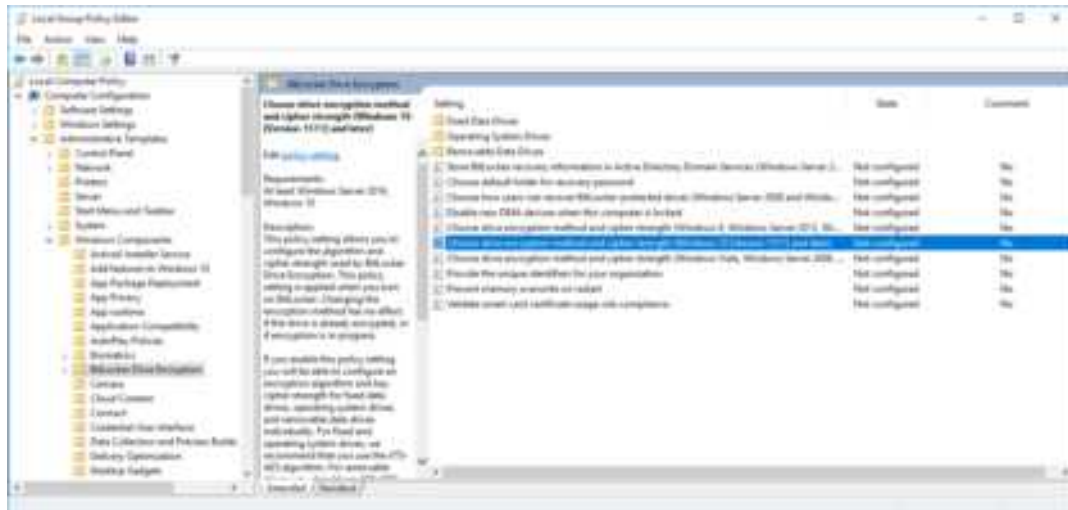


- 3 Navigate to **Computer Configuration > Administrative Templates > Windows Components > BitLocker Drive Encryption**.



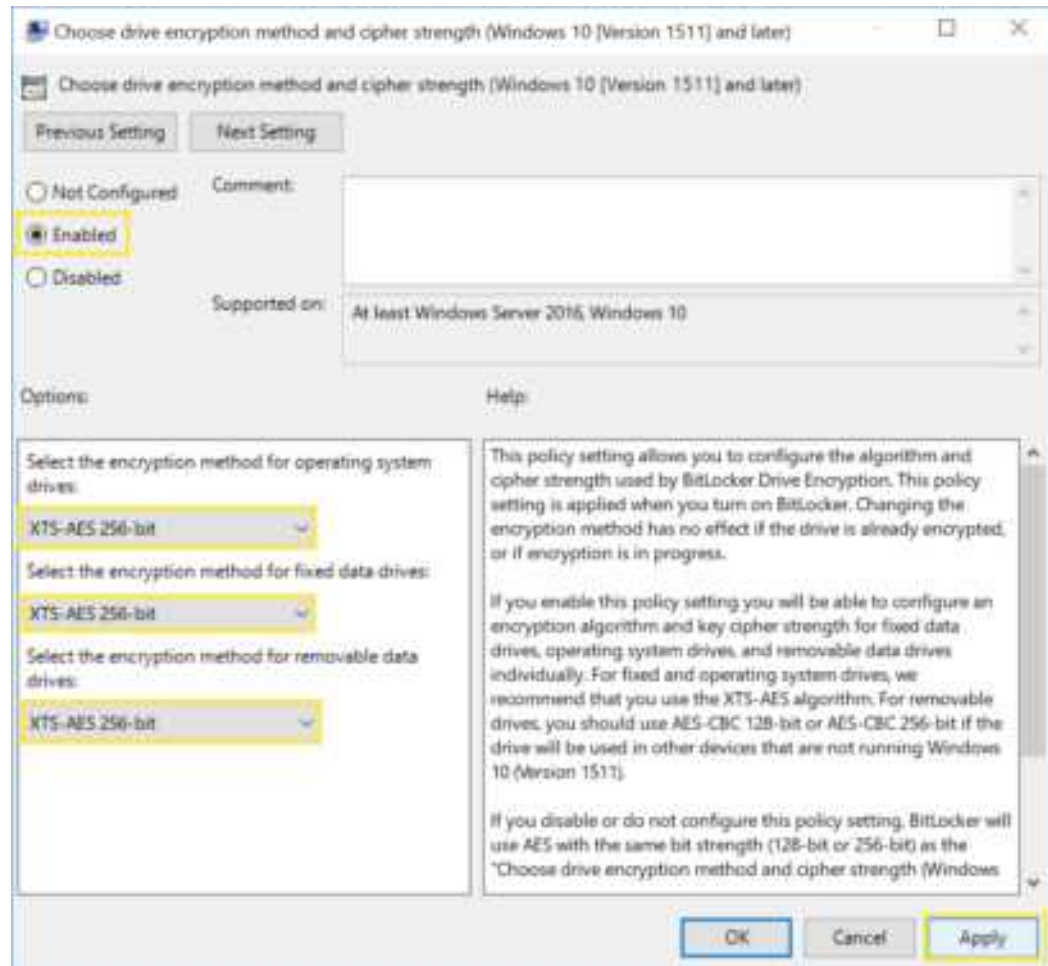
- 4 Double-click “Choose drive encryption method and cipher strength (Windows 10....)”. Refer to Figure G.1.

Figure G.1 Choosing Drive Encryption Method and Cipher Strength



- 5 Select **Enabled** and use the drop-down arrows to select the encryption method for the operating system drive, fixed data drive, and for the removable data drives, see [Figure G.2](#).

**Figure G.2** Choosing the Encryption Level

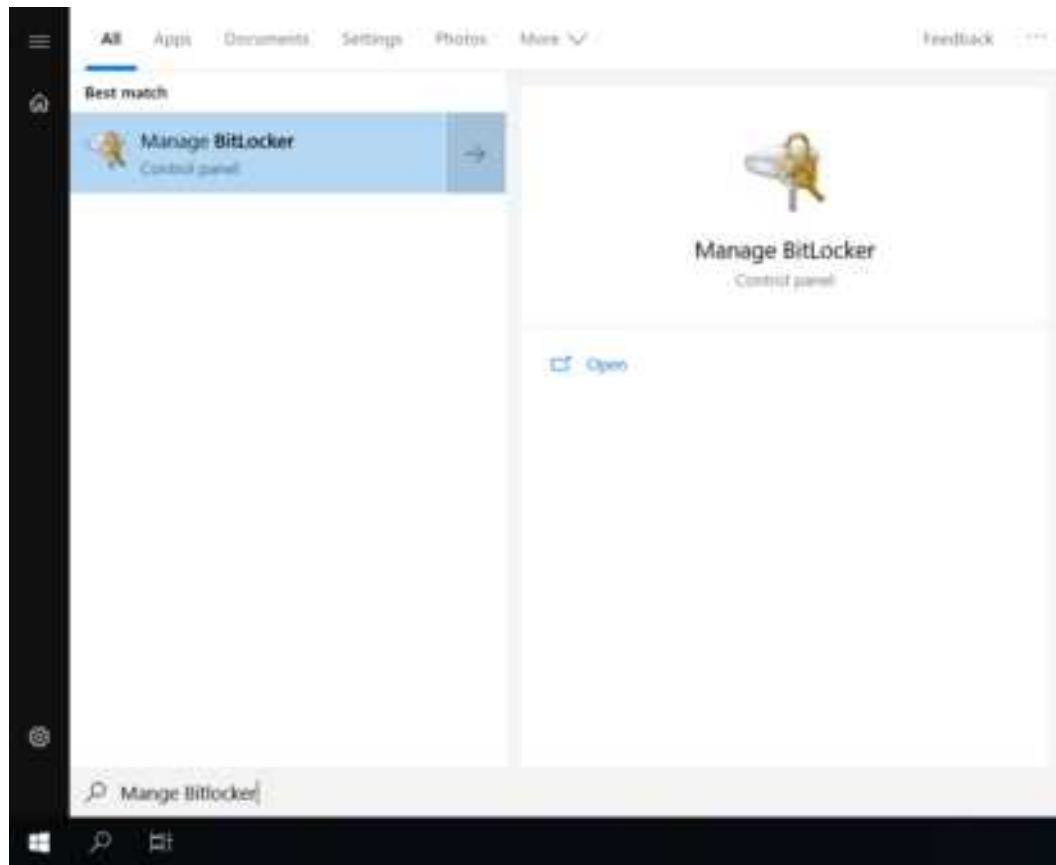


**NOTE** The default is set to XTS-AES 128-bit.

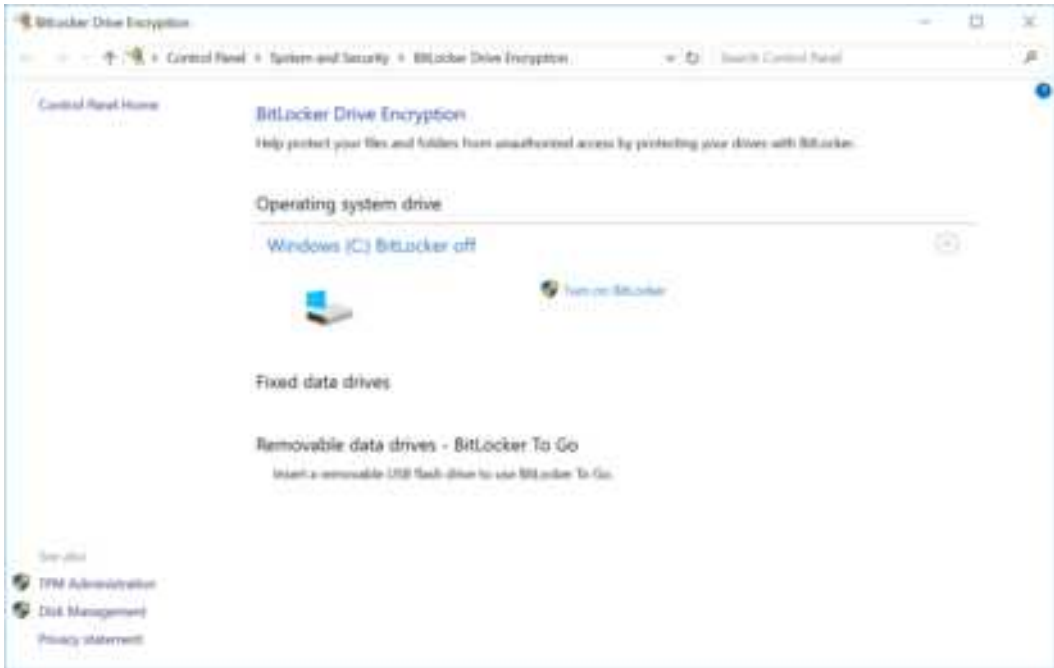
- 6 Select **Apply**.
- 7 Select **OK** and close all windows.
- 8 Restart the computer and proceed to [Enabling BitLocker](#).

## Enabling BitLocker

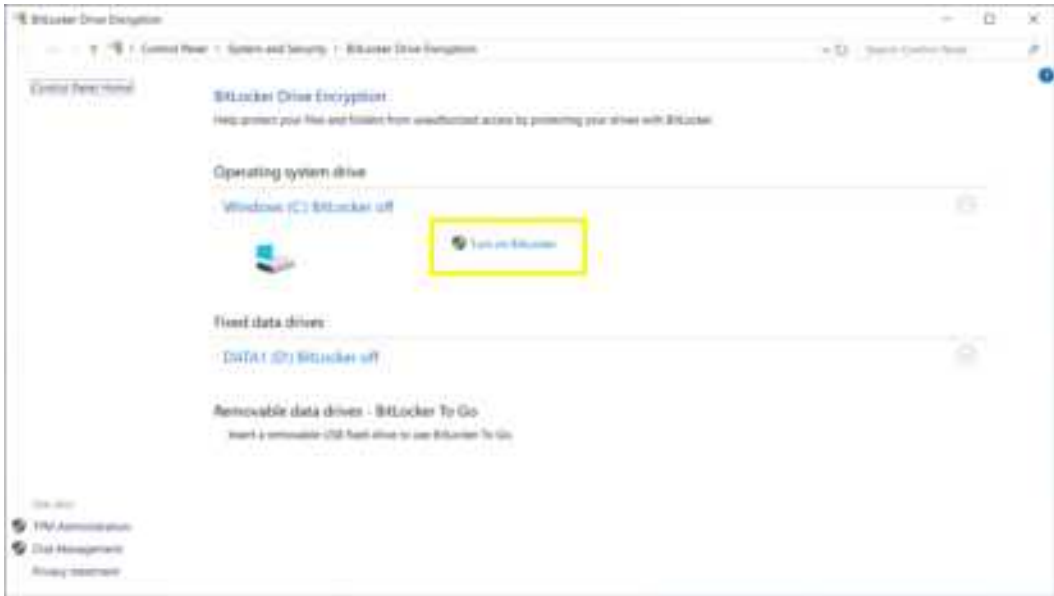
- 1 Type **Manage BitLocker** from the Windows search bar to locate the **Manage BitLocker Control Panel**.



2 Double-click **Manage BitLocker** to open the BitLocker Drive Encryption window.

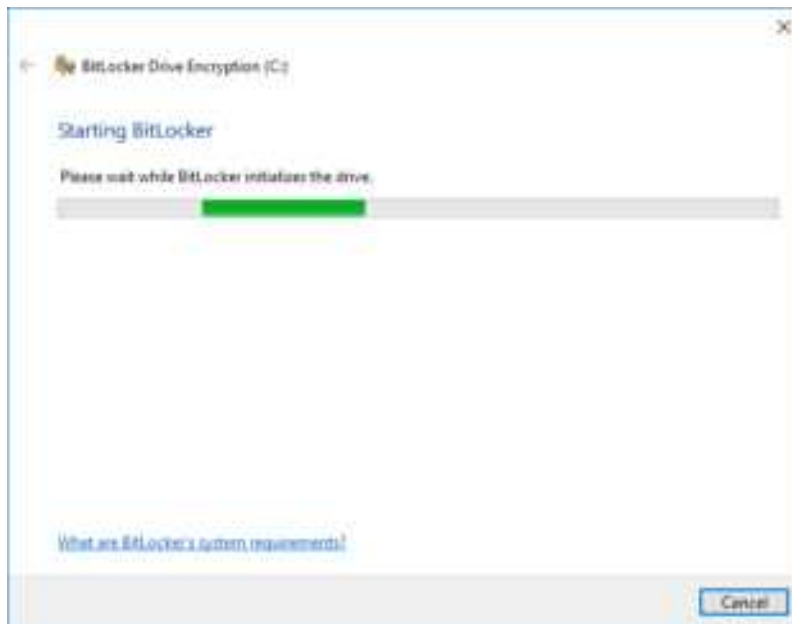


3 Select **Turn on BitLocker** from the Control Panel screen.

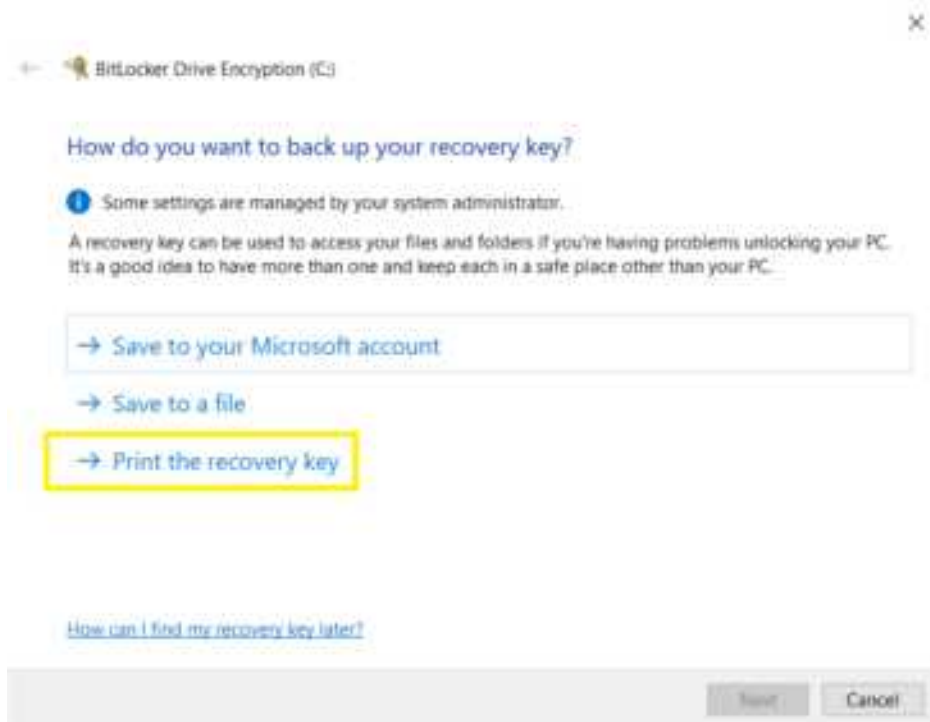


- 4 BitLocker verifies that your PC meets the requirements. Refer to [Figure G.3](#).

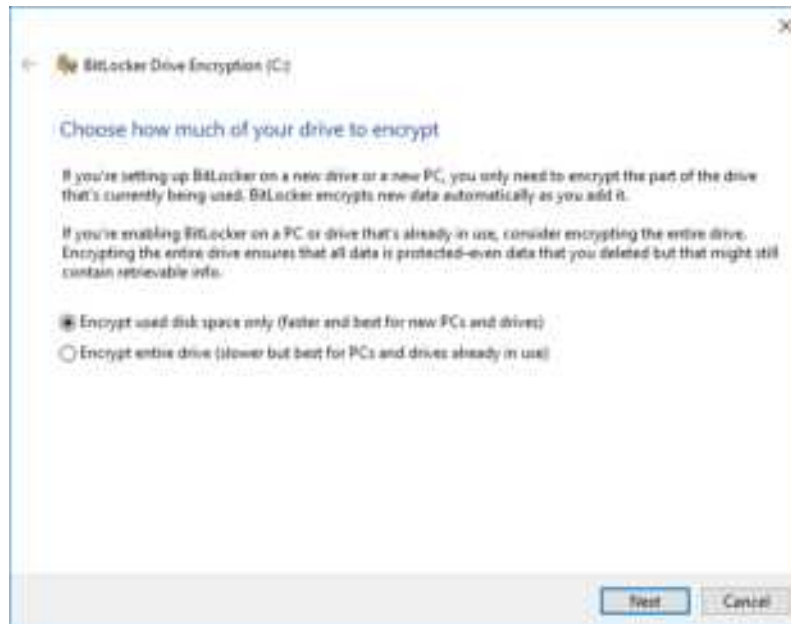
**Figure G.3** Checking PC Configurations



- 5 Select **Print the recovery key** to back up the recovery key. For instructions, refer to [Backing Up Your Recovery Key](#).



- 6 Select “Encrypt used disk space only (faster and best for new PCs and drives)”, then select **Next**.



- 7 Select “New encryption mode (best for fixed drives on this device)”, then select **Next**.



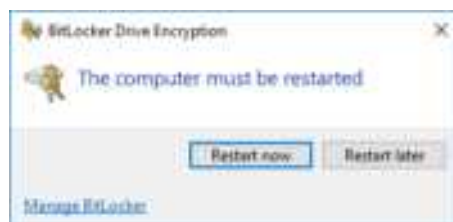
**IMPORTANT** The system check ensures that BitLocker can read the recovery and encryption keys correctly before encrypting the drive. This check might take some time, but it is recommended to ensure that your selected unlock method works without requiring the recovery key.

8 Select “Run BitLocker system check”, then select **Start encrypting**.



**NOTE** BitLocker restarts your computer before encrypting.

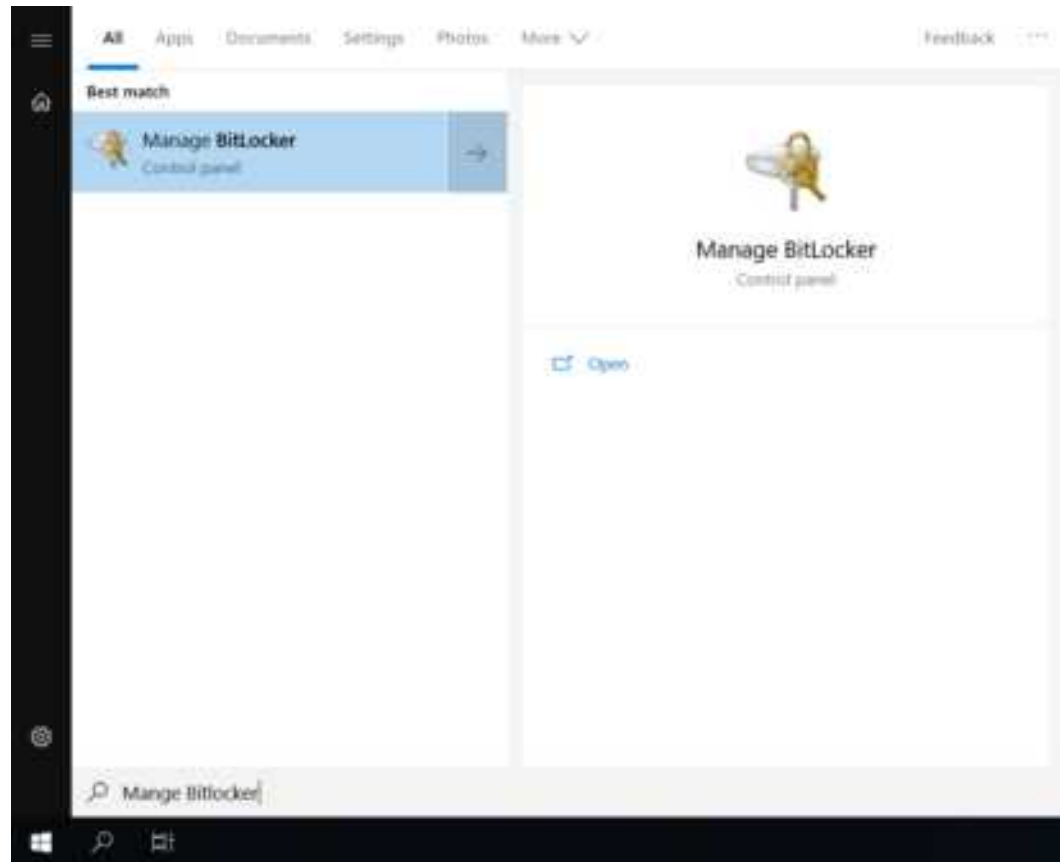
9 Select **Restart now** to start the BitLocker Encryption.



10 Enter your password in the Password screen.

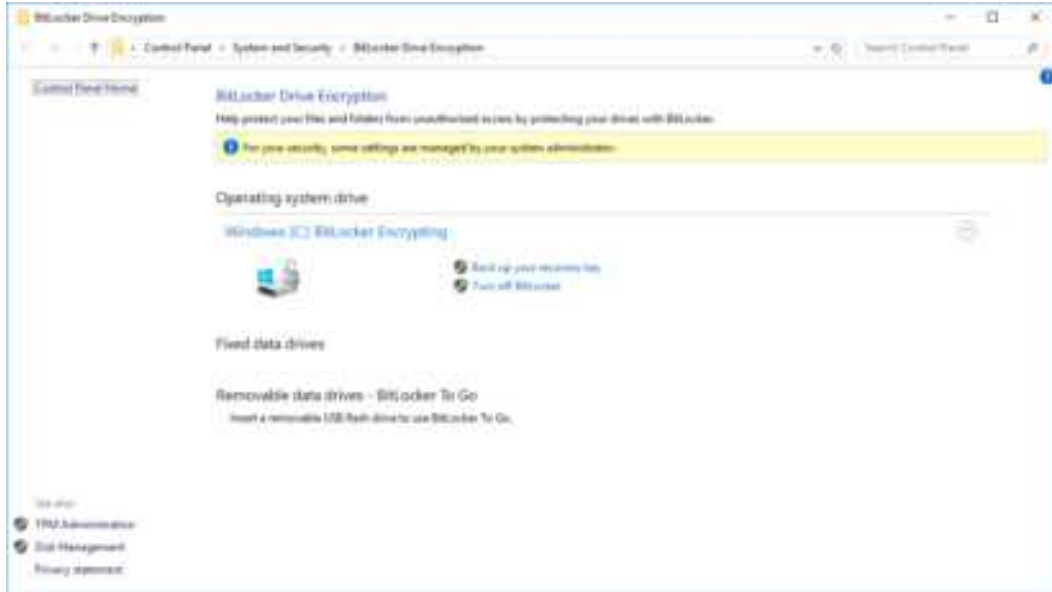
**NOTE** After logging in you will see a Window that says **Encrypting in Progress**.

11 Open the **Manage BitLocker Control Panel** from the Windows search bar.



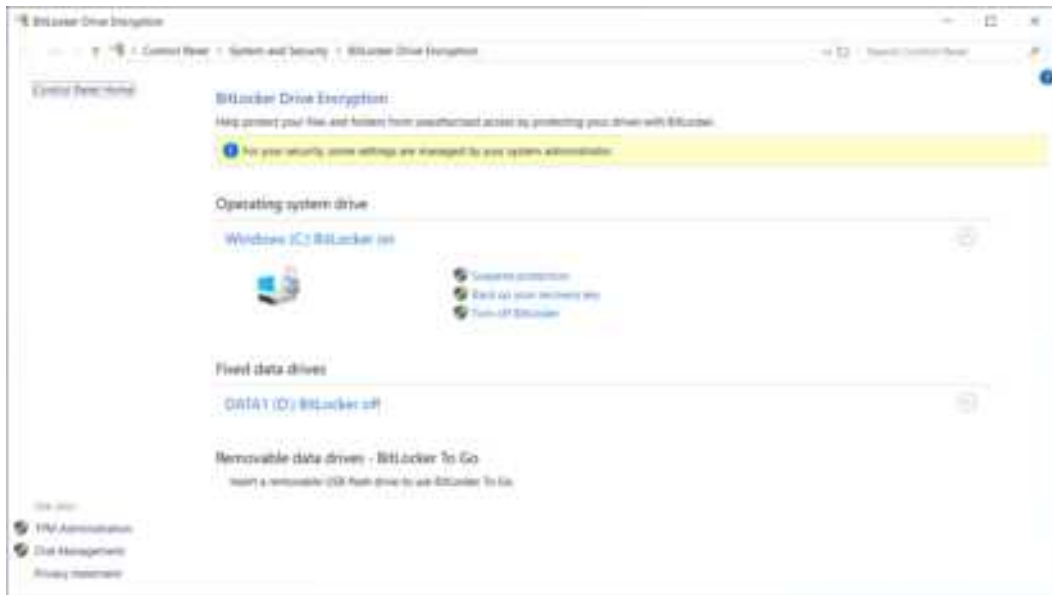
12 Under Operating System Drive, you will see the BitLocker is Encrypting the drive. See [Figure G.4](#).

Figure G.4 BitLocker Encrypting the Drive



13 Once the BitLocker has encrypted the drive, the BitLocker will be on. See [Figure G.5](#).

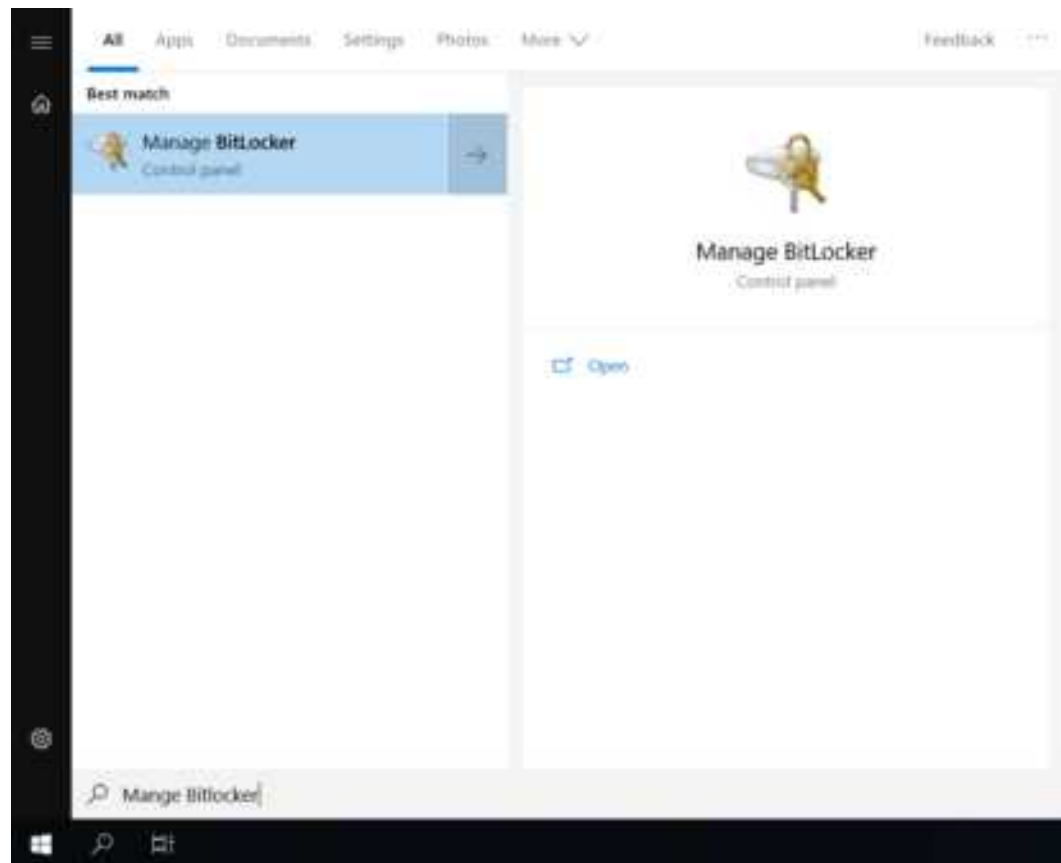
Figure G.5 BitLocker Successfully On



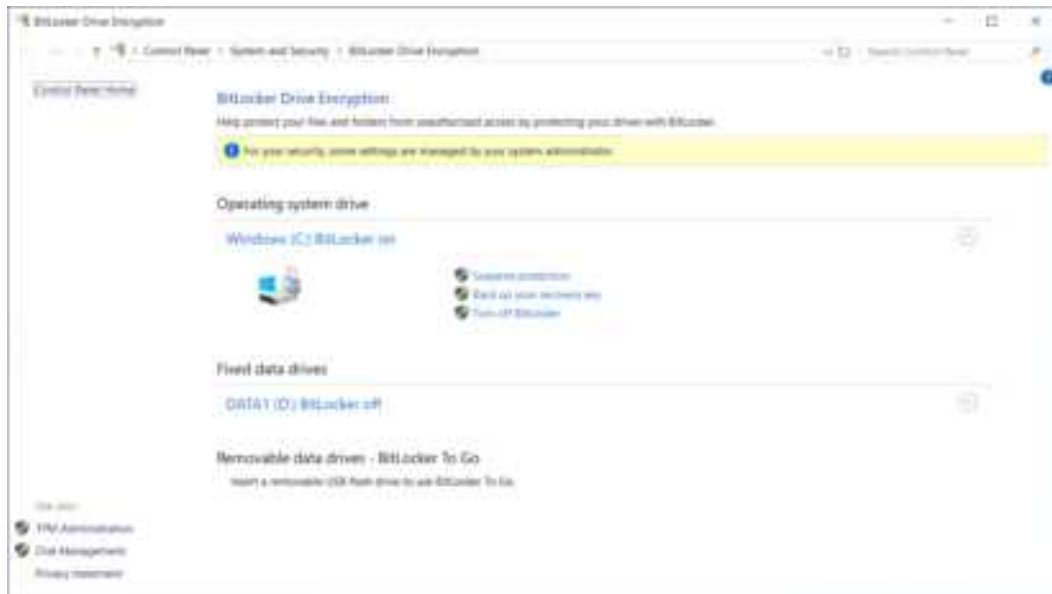
## Backing Up Your Recovery Key

**IMPORTANT** The Back Up Your Recovery Key to your Microsoft Account is not supported at this time.

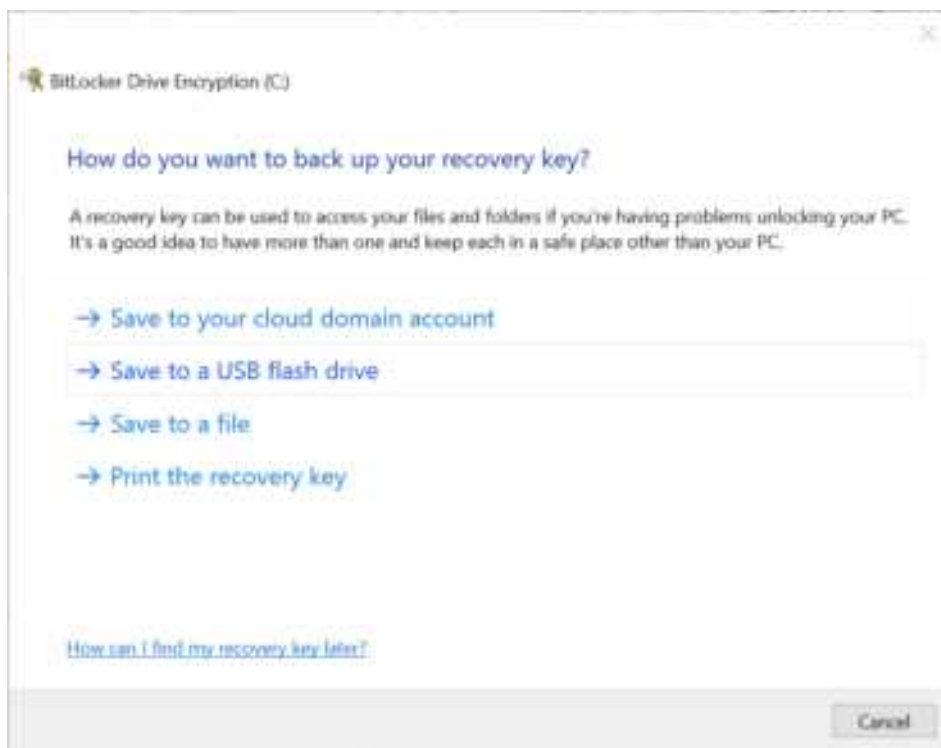
- 1 Type **Manage BitLocker** from the Windows search bar to locate the **Manage BitLocker Control Panel**, see below.



- 2 Double-click Manage BitLocker to open the BitLocker Drive Encryption window.



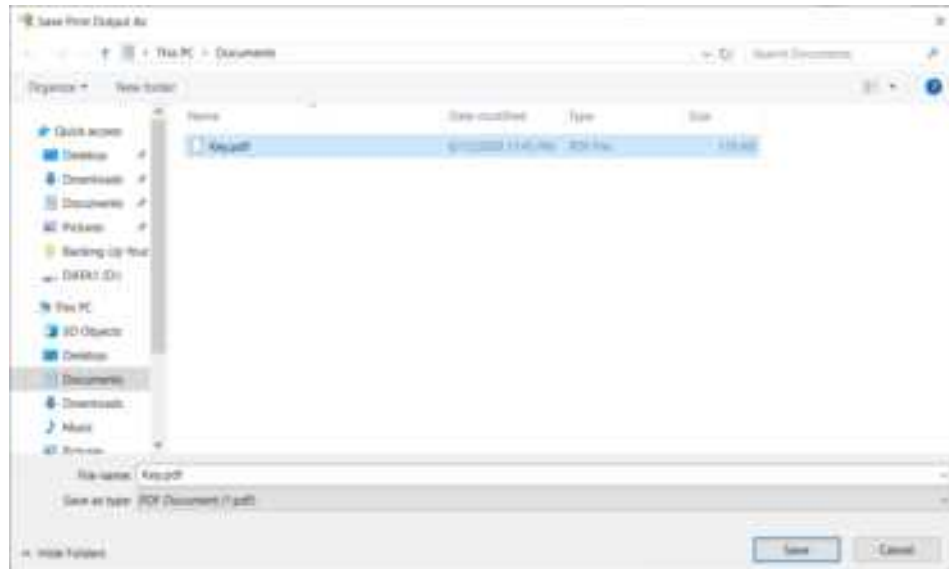
- 3 Select "Backup your recovery key". The following window appears.



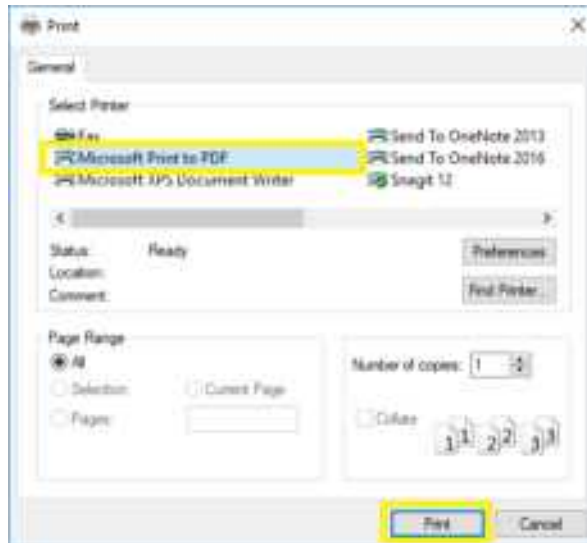
**IMPORTANT** The Recovery Key can only be saved to a USB or external drive. You cannot save to a location on your PC.

**4** Select a destination to save the Recovery Key.

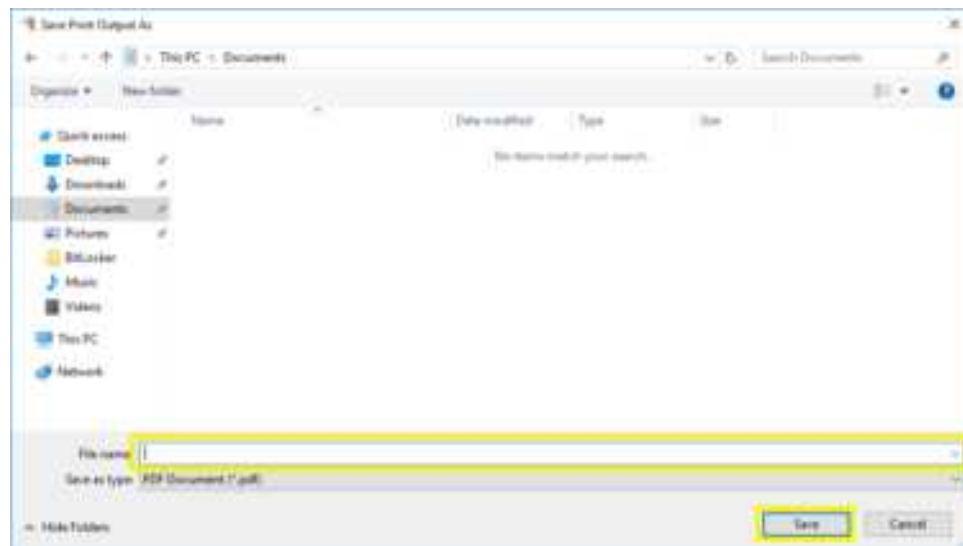
- **Save to a file:** Select “*Save to a file*”. The following screen appears.



- **Print the recovery key:** Select “*Print the recovery key*”. The following screen appears.



1. Select “*Microsoft Print to PDF*”, and then select **Print**.



2. Select the location that you want the file saved. In the File name, type **BitLocker Key** and in the Save as type, ensure that it is listed as.pdf.

---

**5** Select **Save** then select **Finish**.

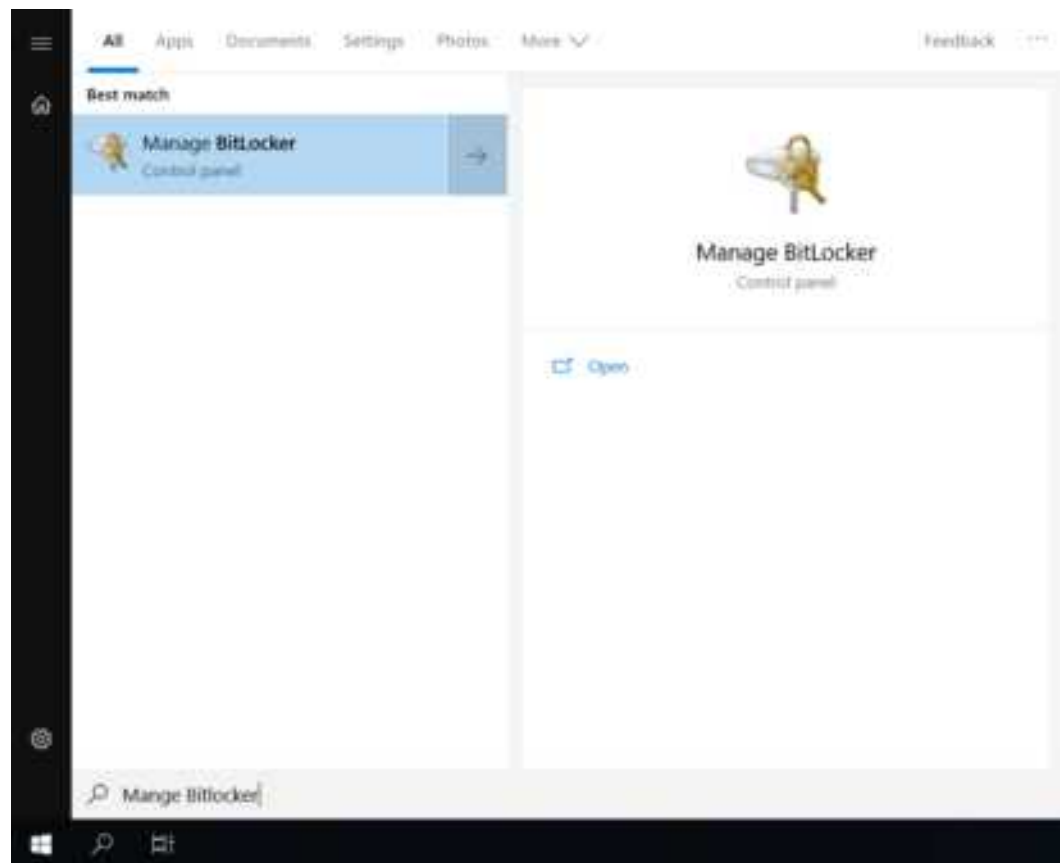
---

## BitLocker Decryption

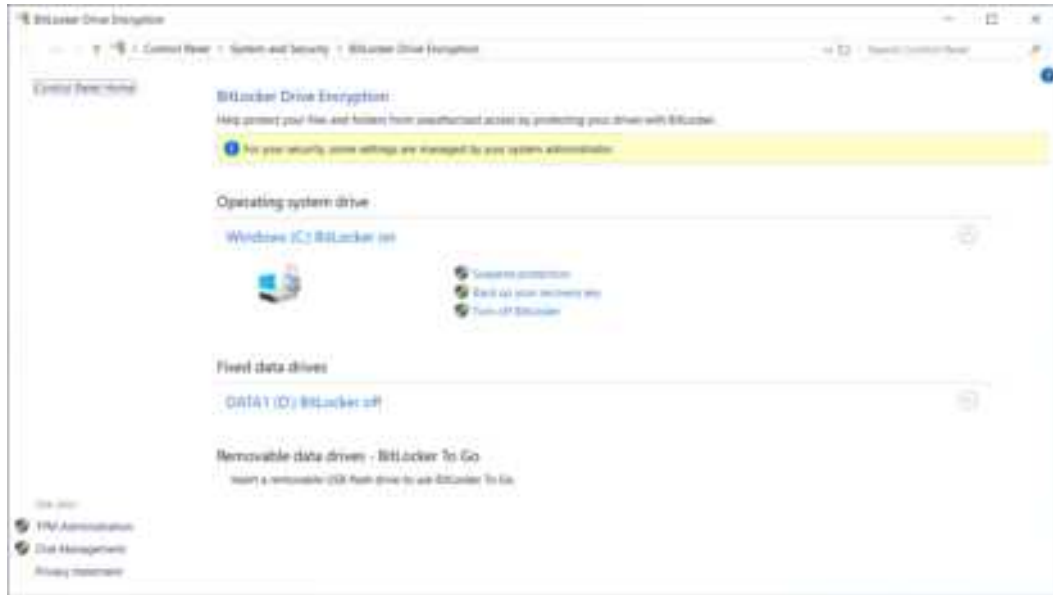
**IMPORTANT** Turning off the BitLocker feature decrypts all the data on the drive. Decrypting your operating system means that you have removed BitLocker from your system. The BitLocker key will change each time BitLocker is re-enabled. Only the latest BitLocker key will work. Previous BitLocker keys will be invalid and will not unlock the system. Please note this is a time-consuming process. However, you can also suspend BitLocker instead of decrypting the drive, see [Suspending BitLocker Drive Encryption](#).

### Turning off BitLocker

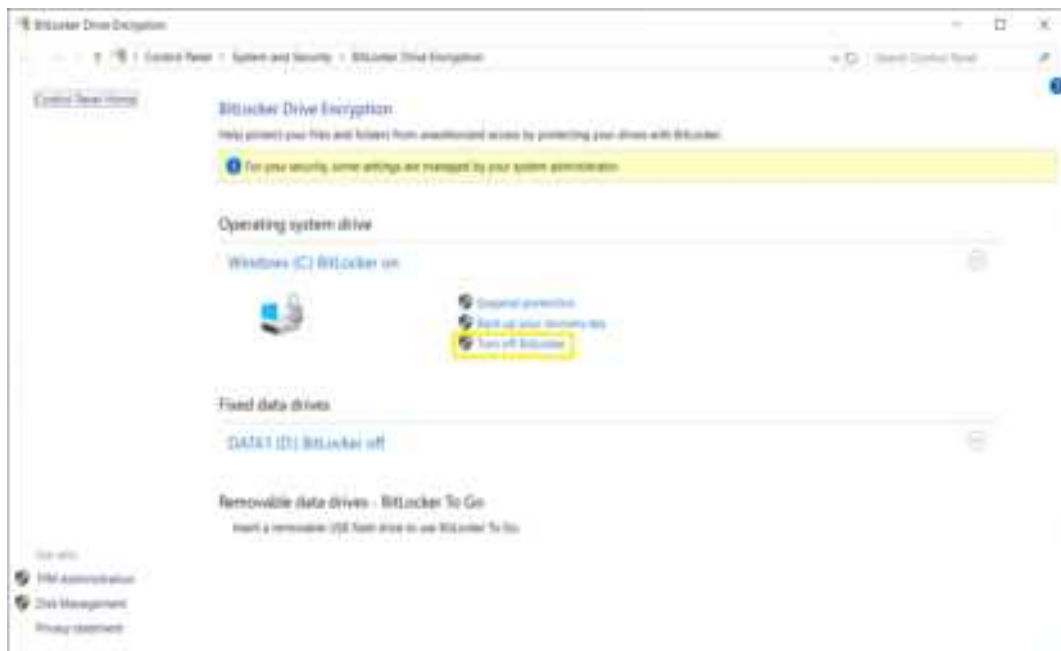
- 1 Type **Manage BitLocker** from the Windows search bar to locate the **Manage BitLocker Control Panel**.



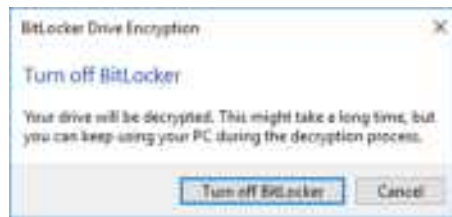
2 Double-click Manage BitLocker to open the BitLocker Drive Encryption.



3 Select Turn off BitLocker.



The following message appears.

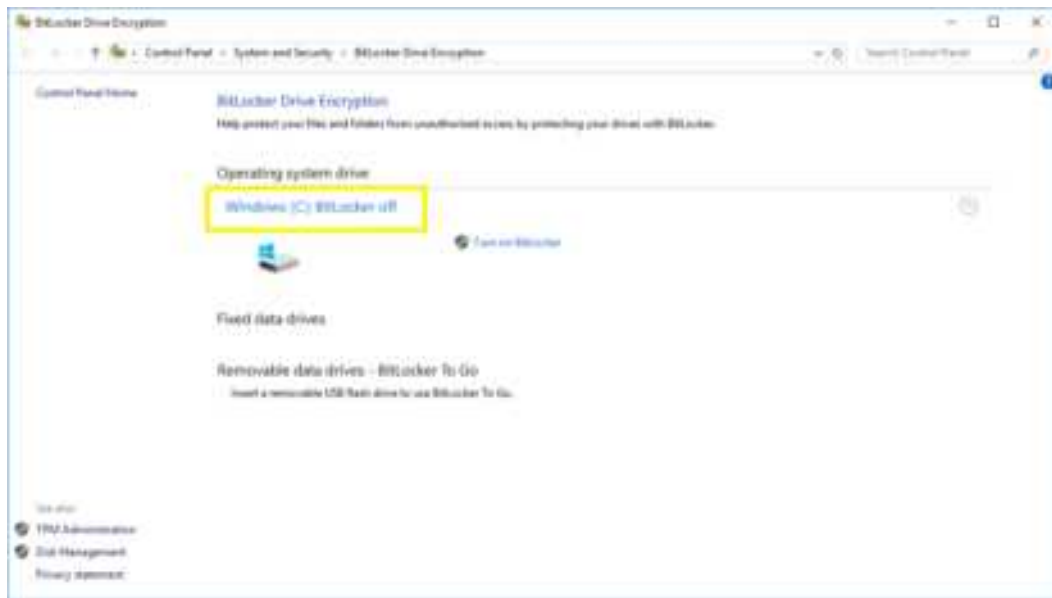


**IMPORTANT** Drive decryption might take a long time, but you can keep using your PC during the decryption process.

**4** Select **Turn off BitLocker**. The BitLocker Drive Decryption screen displays.



After the decryption has completed, the following screen displays.

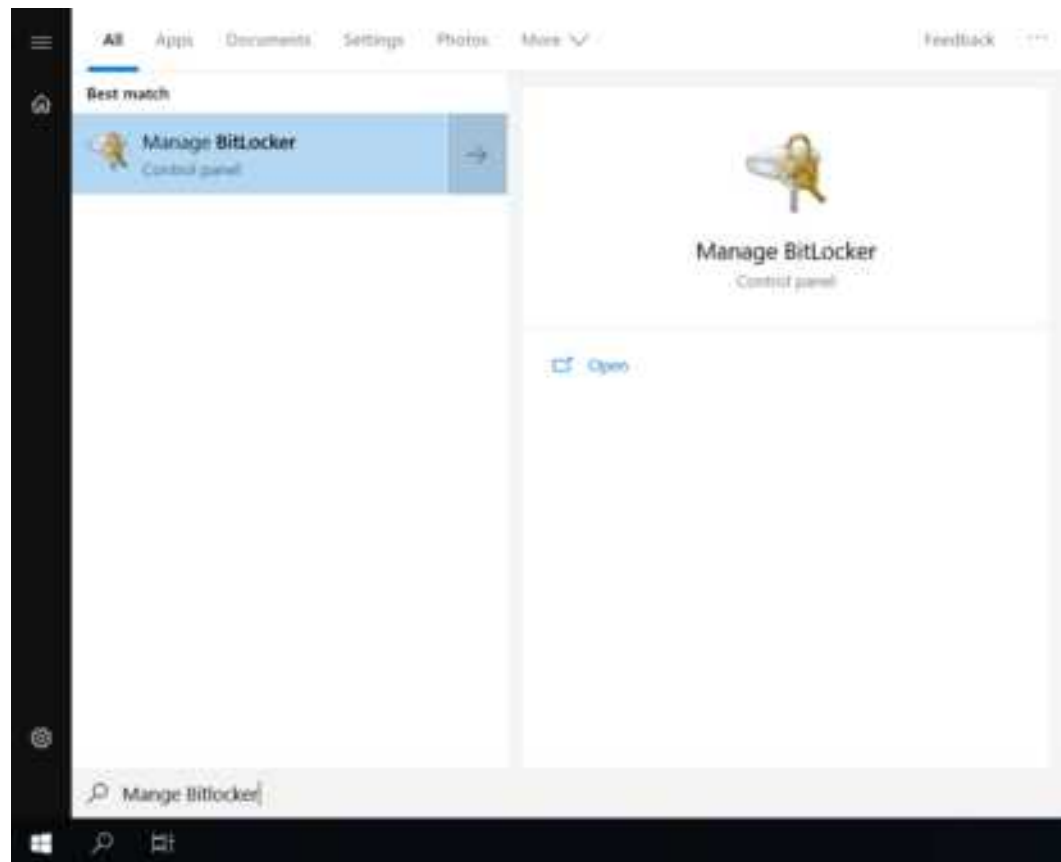


## Suspending BitLocker Drive Encryption

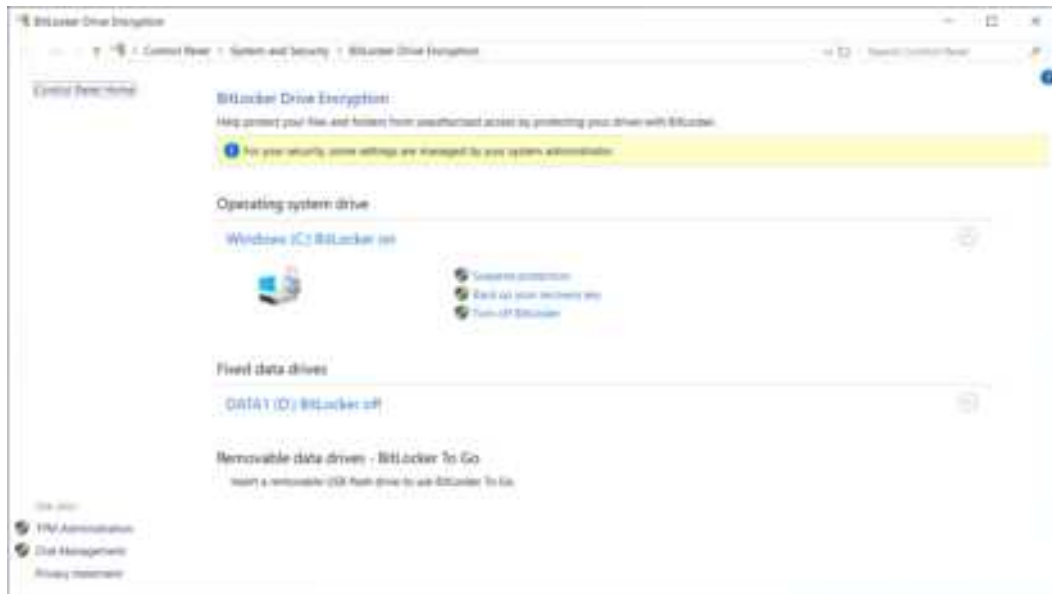
**IMPORTANT** Suspending BitLocker Drive Encryption is a temporary method for removing BitLocker protection without decrypting the Windows drive. Use Suspend BitLocker if you need to update the BIOS firmware or Windows boot loader/startup files that requires access to the drive in a pre-boot environment. This will help prevent BitLocker from locking the drive and can avoid a lengthy decryption process.

### Suspending BitLocker

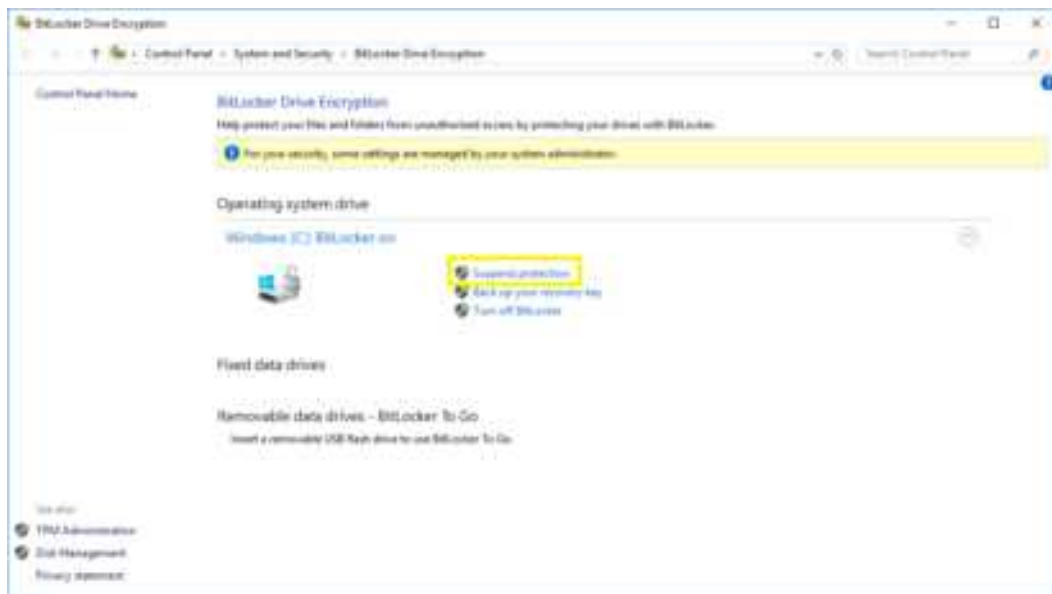
- 1 Type **Manage BitLocker** from the Windows search bar to locate the Manage BitLocker Control Panel.



2 Double-click Manage BitLocker to open the BitLocker Drive Encryption window.



3 Select **Suspend protection**.



A confirmation message “Do you want to suspend BitLocker protection?” displays.



---

**IMPORTANT** If you choose to suspend BitLocker, your data will not be protected.

**4** If you want to proceed, select **Yes** and the following popup information will display.



If you do not want to proceed, select **No**.

**NOTE** There are certain situations where you may want to suspend BitLocker such as updating your PC's firmware, hardware, or operating system. If you forget to resume BitLocker after these updates are completed, BitLocker will resume automatically the next time you restart your PC.

---

## Restarting BitLocker Protection

**1** Select **Resume Protection**.

---

## Recovering Your BitLocker Key

There might be situations where the BitLocker Key is requested from your computer, such as:

- Your drive is placed onto another computer
- Computer requests your recovery key, it may be due to one of the following but is not limited to:
  - Hardware changes
  - Firmware changes
  - Other Windows updates

## BitLocker Recovery

---

- 1 BitLocker Recovery window will be displayed upon powering on your system.



- 2 Enter your key from your saved text file or printed copy, then select **Enter**.



- 3 Windows will reboot your computer.

## Protection from Malware Software

 **CAUTION**

**The instrument workstation is vulnerable to malware, viruses, and unauthorized access if the instrument PC is connected directly to the laboratory network without installation of all approved OS and malware patches.**

**IMPORTANT** Only the version of the McAfee Application Control (Version 8.3) has been validated to work with the CytoFLEX platform instrument.

For more information on Configuration of McAfee Application Control, refer to McAfee Application Control Guide.

## Installing McAfee Application Control

**IMPORTANT** The McAfee Application Control Software (version 8.3) should be purchased separately from Trellix/McAfee.

1 Unzip the McAfee Application Control file  **SOLIDCORxxx\_xxx\_WIN.zip**

2 Right-click **Setup-win-8-10-2012-amd64-xxx.exe**, and select **Run as administrator**. The McAfee Installer opens.



- 3 Select **Next**. The License Agreement displays.



Read the license agreement and select **I accept the terms in the license agreement**, then select **Next**.

- 4 Enter the username and the serial number.

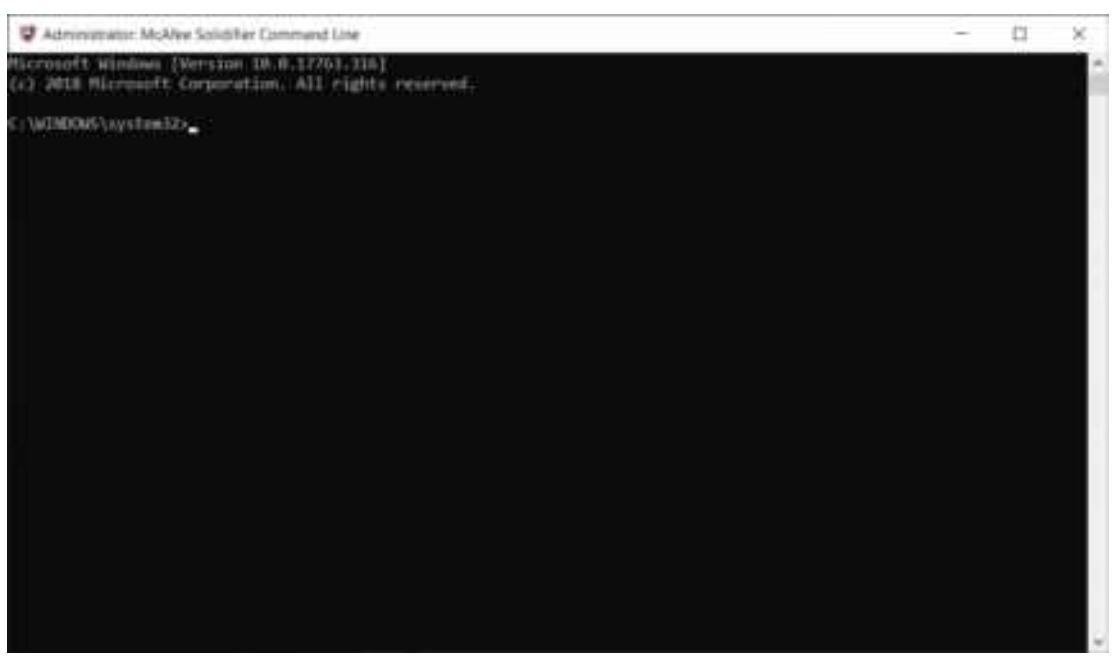


If you select **Install without license key**, follow the procedures below to add the license key after the installation.

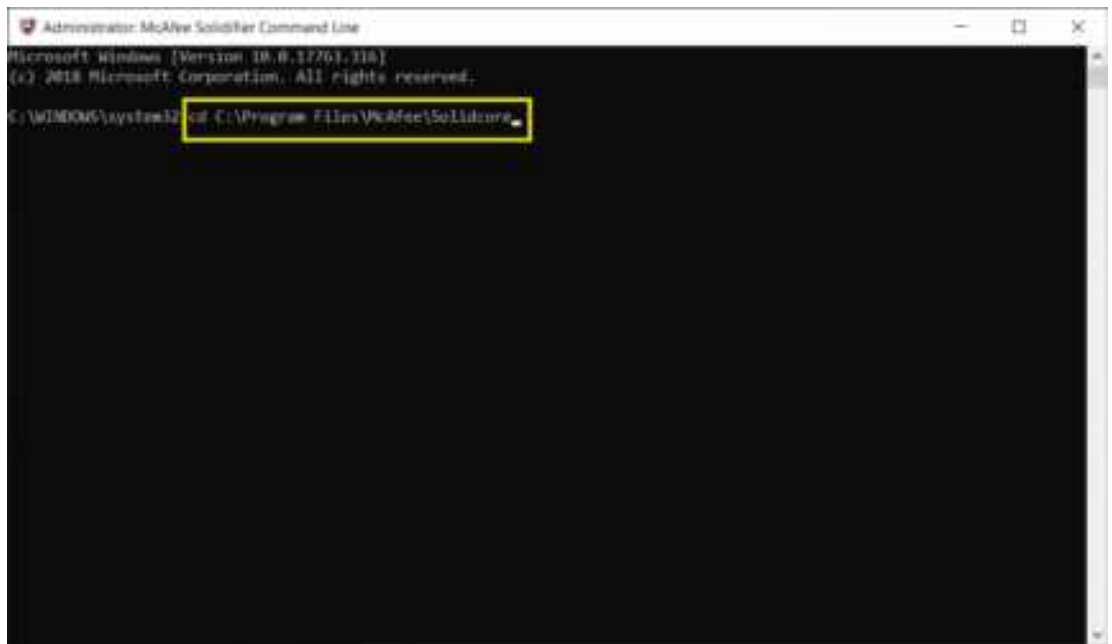
- a. Right-click  on your desktop, and select **Run as administrator**.



The following window displays.



- b. Enter `cd C:\Program Files\McAfee\Solidcore.`



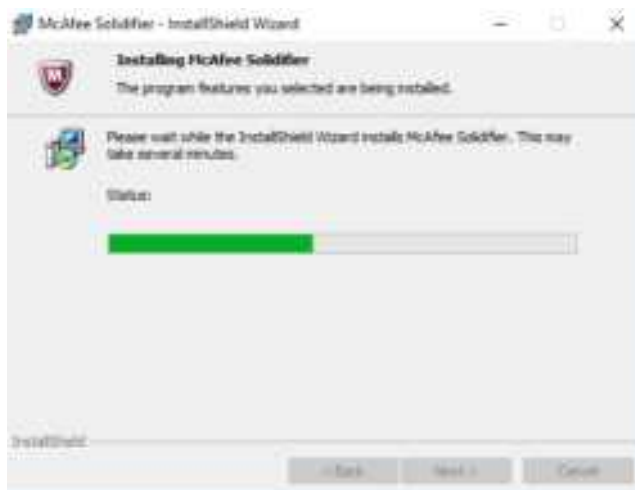
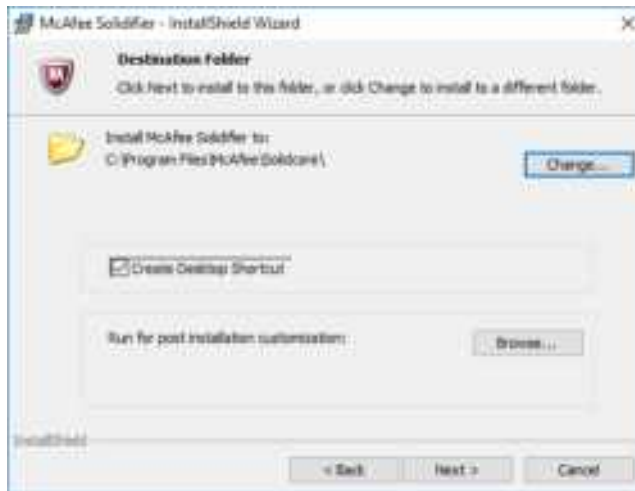
- c. Enter the license key in the console.



The license key is added.



5 Select Next.



- 
- 6 Select the destination folder and select **Next**. The system starts to install McAfee Solidifier.




- 
- 7 Select **Finish**.
-

## Enabling McAfee Application Control

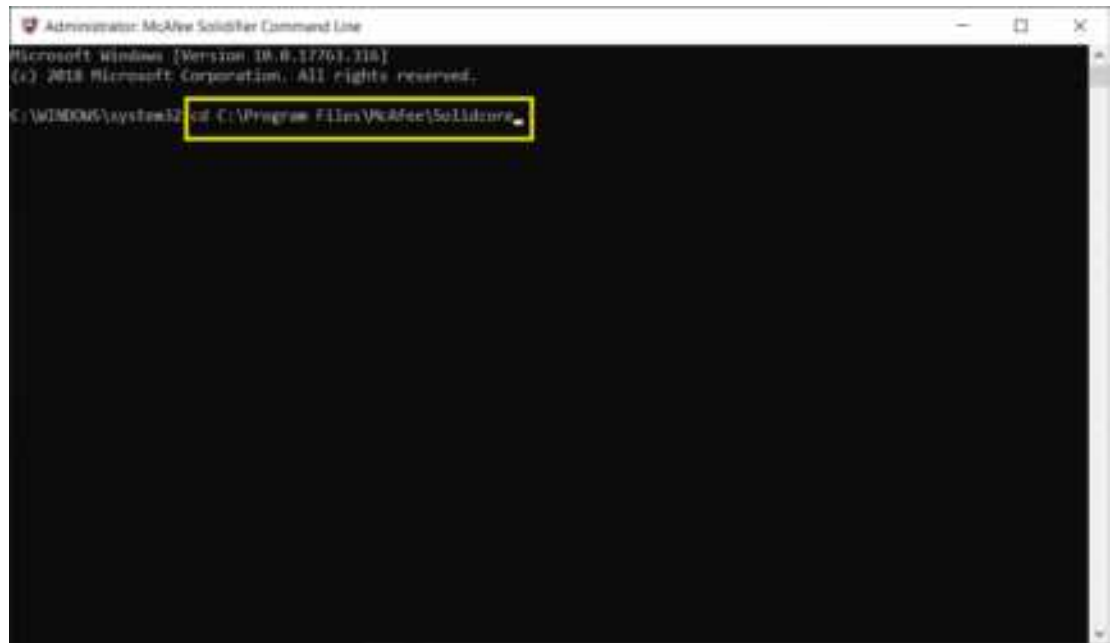
The enabled McAfee Application Control Software prevents your system from executing unauthorized applications on your instrument workstation.

**IMPORTANT** Ensure all the necessary applications have been installed prior to enabling the McAfee Application Control.

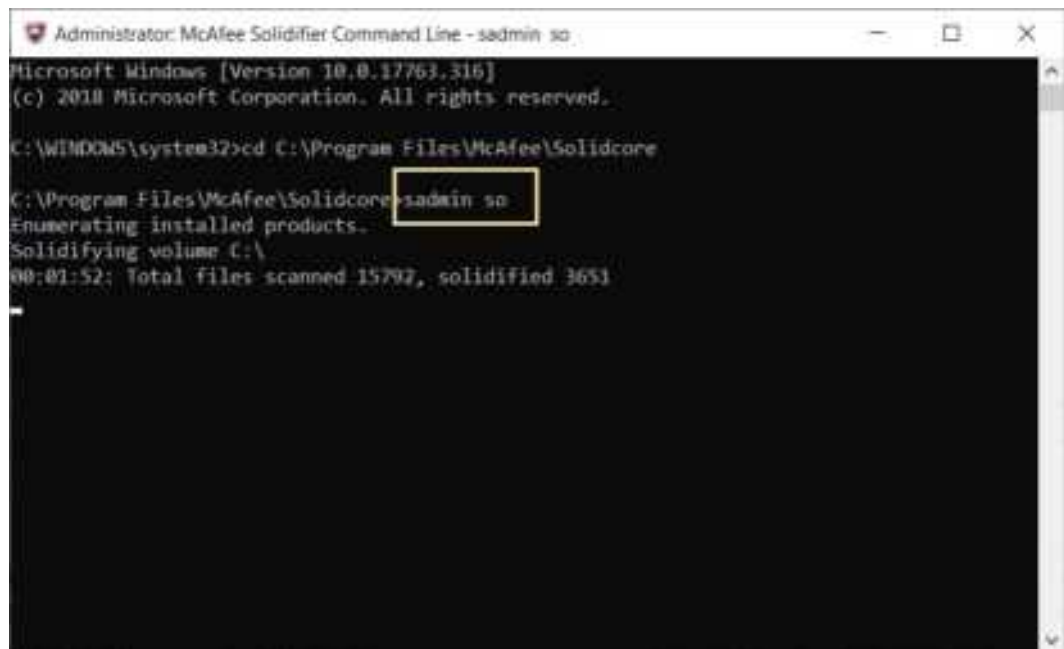
- 1 Right-click  on your desktop, and select **Run as administrator**. The following window displays.



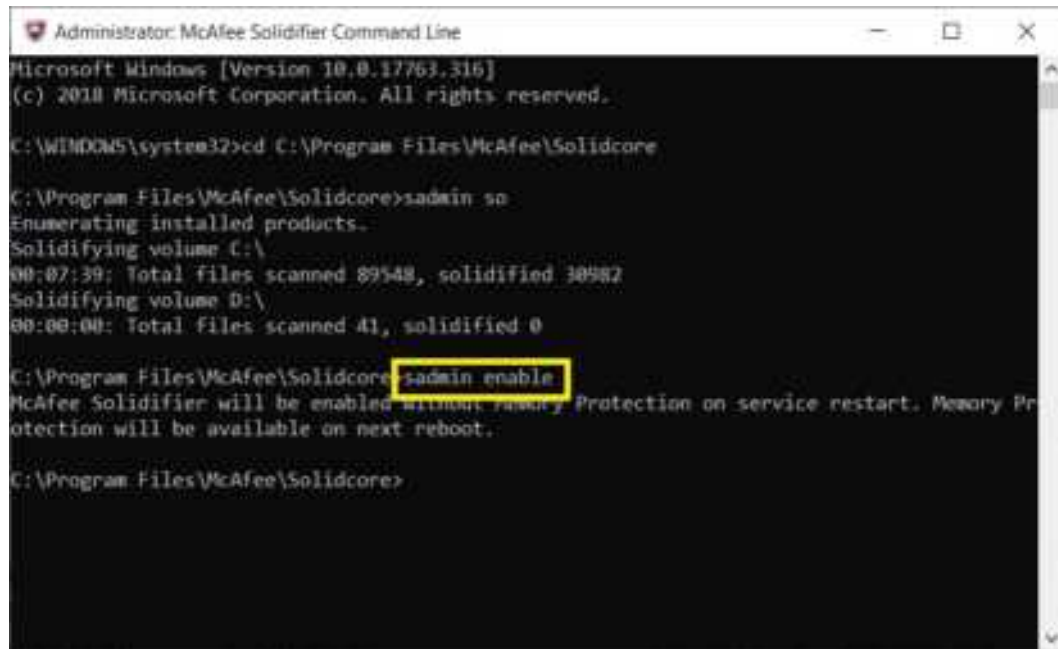
- 2 Enter `cd C:\Program Files\McAfee\Solidcore`.



- 3 Enter `sadmin so` in the console to scan the system and create a white list. The solidification process takes about 30 minutes depending on your system size and CPU performance.



- 4 Enter **admin enable** to enable the McAfee Application Control.



```
Administrator: McAfee Solidifier Command Line
Microsoft Windows [Version 10.0.17763.316]
(c) 2018 Microsoft Corporation. All rights reserved.

C:\WINDOWS\system32>cd C:\Program Files\McAfee\Solidcore

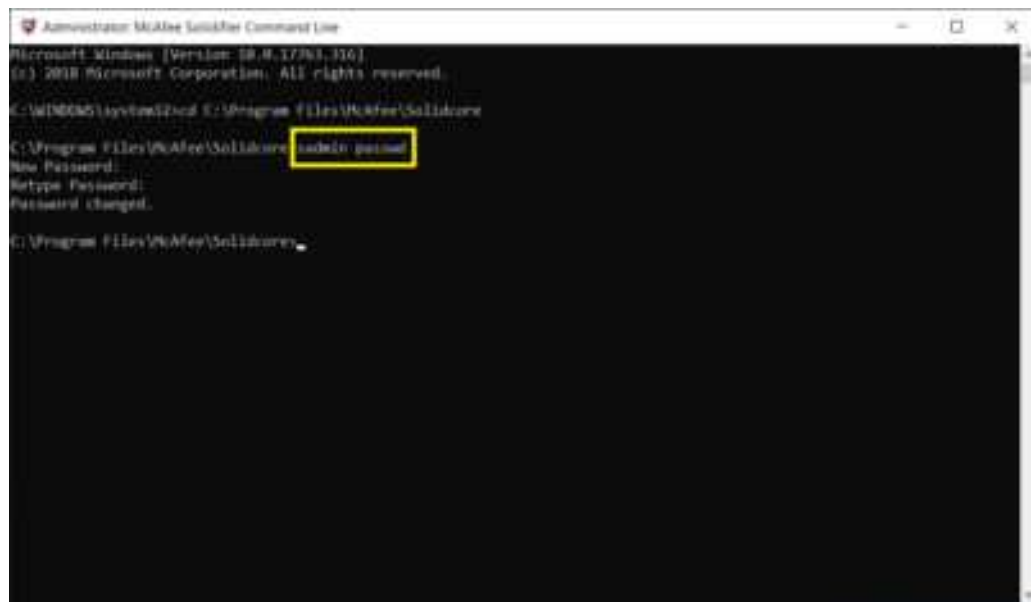
C:\Program Files\McAfee\Solidcore>admin so
Enumerating installed products.
Solidifying volume C:\
00:07:39: Total files scanned 89548, solidified 30982
Solidifying volume D:\
00:00:00: Total files scanned 41, solidified 0

C:\Program Files\McAfee\Solidcore>admin enable
McAfee Solidifier will be enabled without memory protection on service restart. Memory Protection will be available on next reboot.

C:\Program Files\McAfee\Solidcore>
```

**IMPORTANT** Beckman Coulter recommends setting a password to manage the authority of enabling/disabling the McAfee Application Control.

- 5 Enter **admin passwd** to set a password to lock the McAfee Application Control authority.



```
Administrator: McAfee Solidifier Command Line
Microsoft Windows [Version 10.0.17763.316]
(c) 2018 Microsoft Corporation. All rights reserved.

C:\WINDOWS\system32>cd C:\Program Files\McAfee\Solidcore

C:\Program Files\McAfee\Solidcore>admin passwd
New Password:
Retype Password:
Password changed.

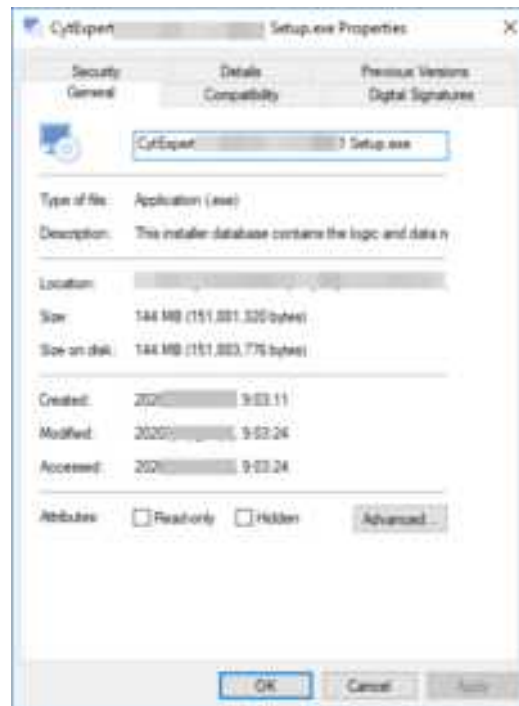
C:\Program Files\McAfee\Solidcore>
```

- 6 Restart the system.

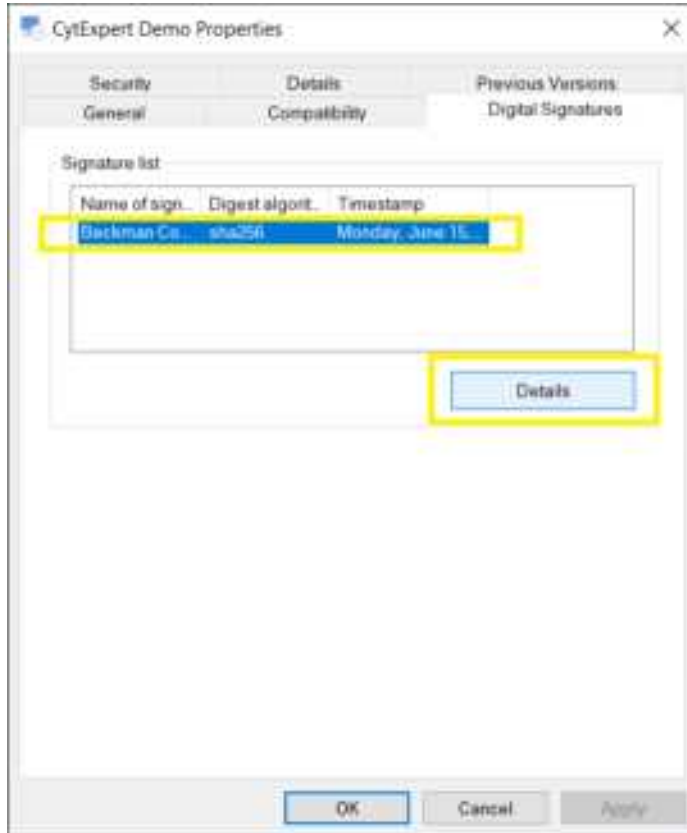
## Exporting the Certificate

Follow procedures below to export the certificate of CytExpert software into your PC.

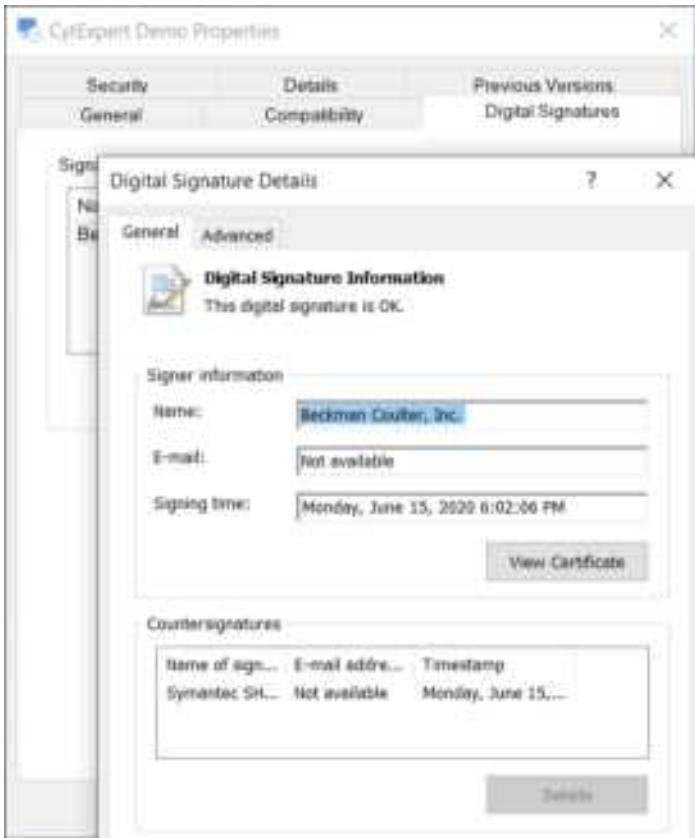
- 1 Right-click on the application **CytExpert for xxxx Setup**, and select **Properties**. The following window displays.



- 2 Select the **Digital Signatures** tab. Then select the signature and select **Details** to view the signature information.



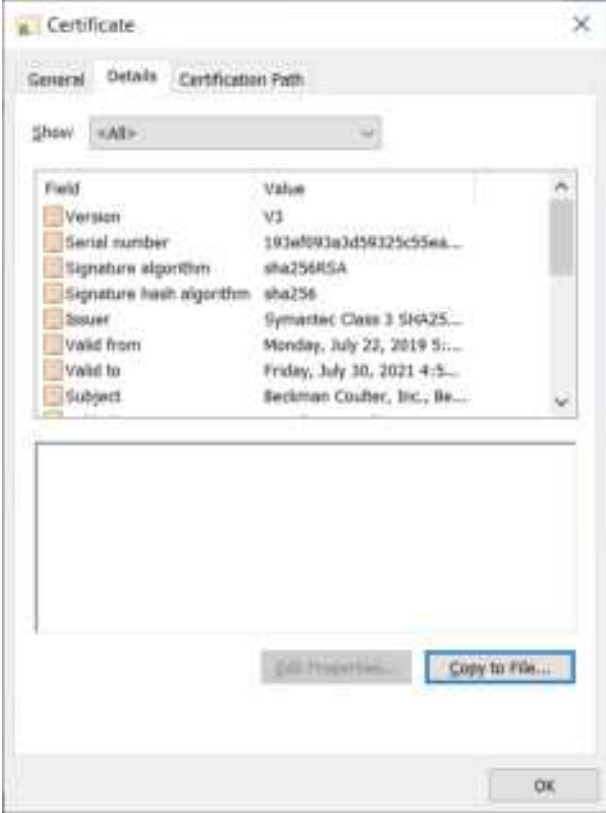
The Digital Signature Details window displays.



3 Select **View Certificate**.



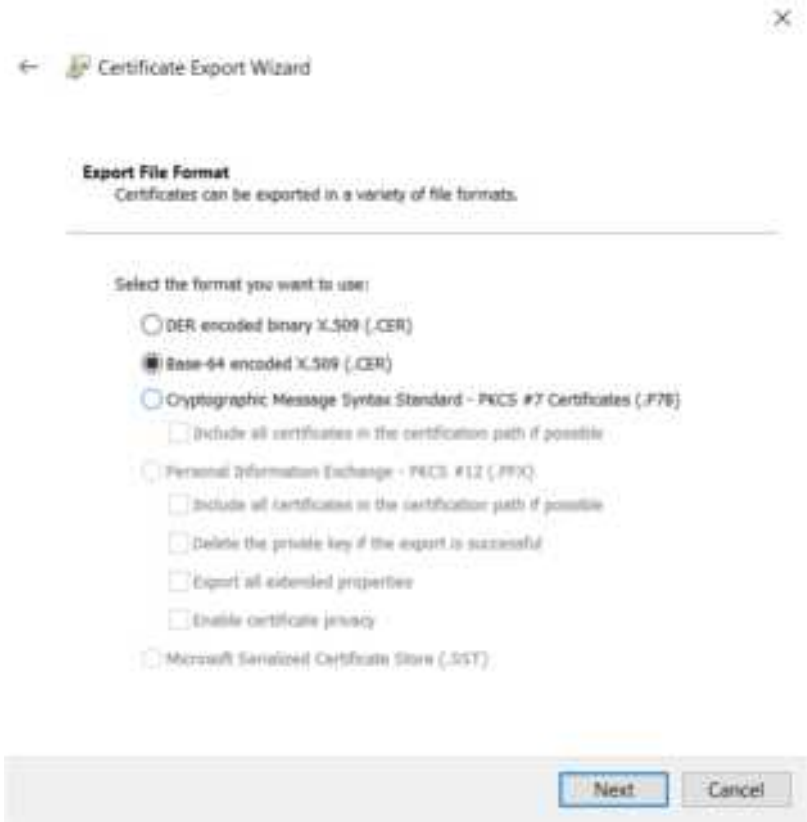
4 Select the **Details** tab and then select **Copy to File**.



The Certificate Export Wizard window appears.



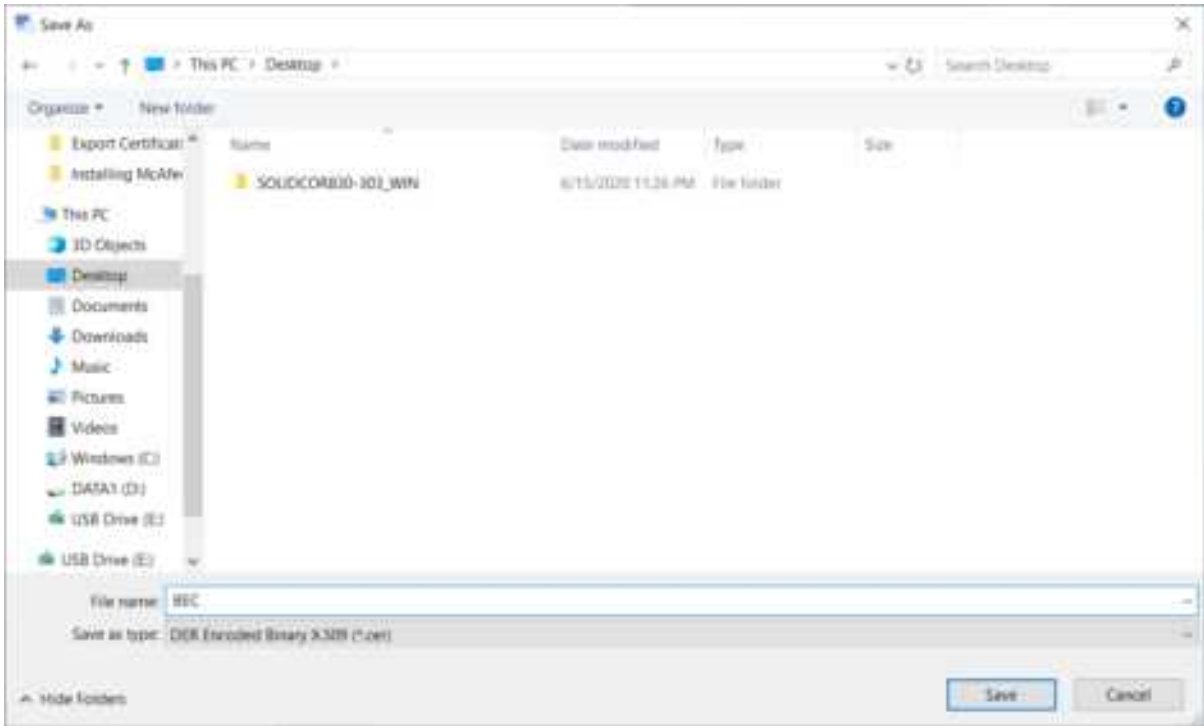
5 Select **Next** to export the certificate.



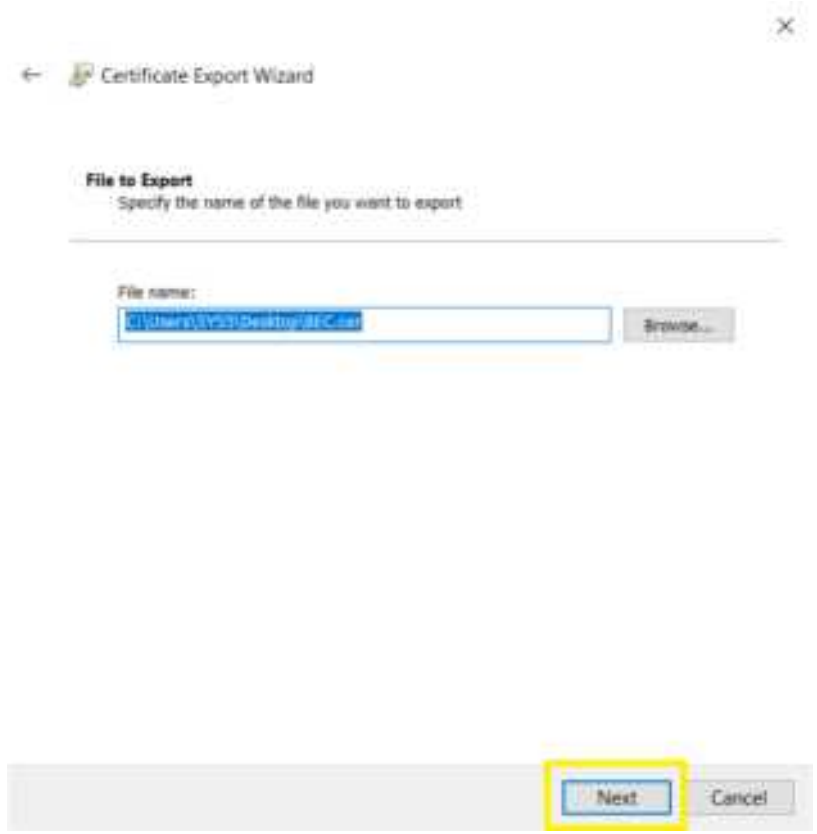
**6** Select **Base-64-encoded X.509** and then select **Next**.



7 Select a destination to save the certificate and then select **Save**.



8 Select **Next**.



- 9 Select **Finish** when the success message displays.




## Importing BEC Certificate

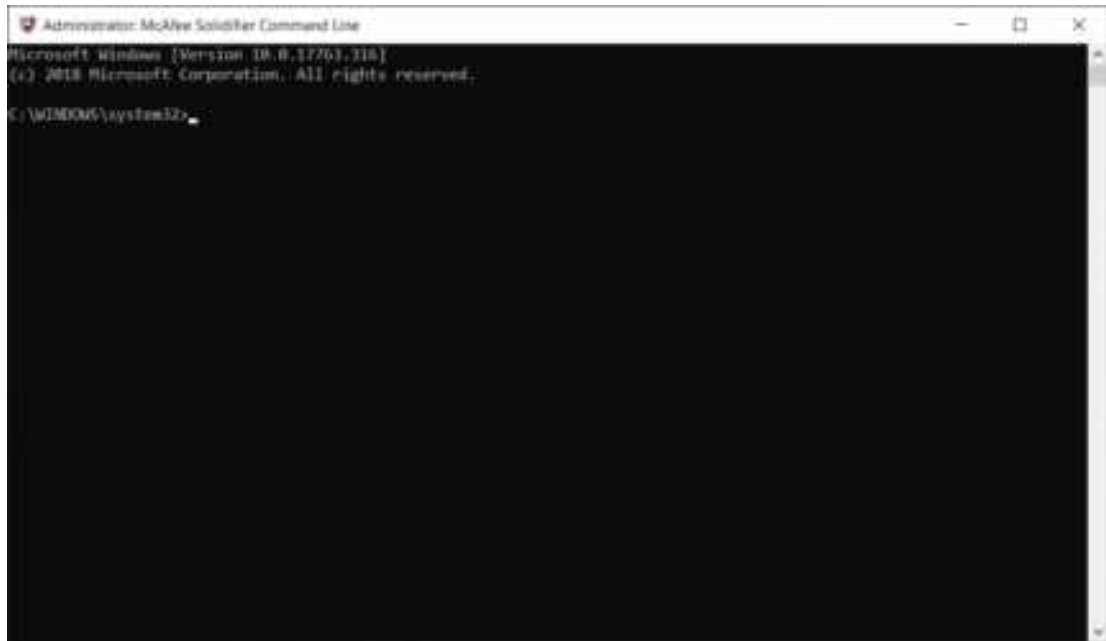
Follow the procedures below to add the certificate of CytExpert software into the McAfee Certificate list. All the certified applications will be regarded as trusted and authorized by the McAfee Application Control.

**IMPORTANT** McAfee Application Control recognize only X.509 certificates.

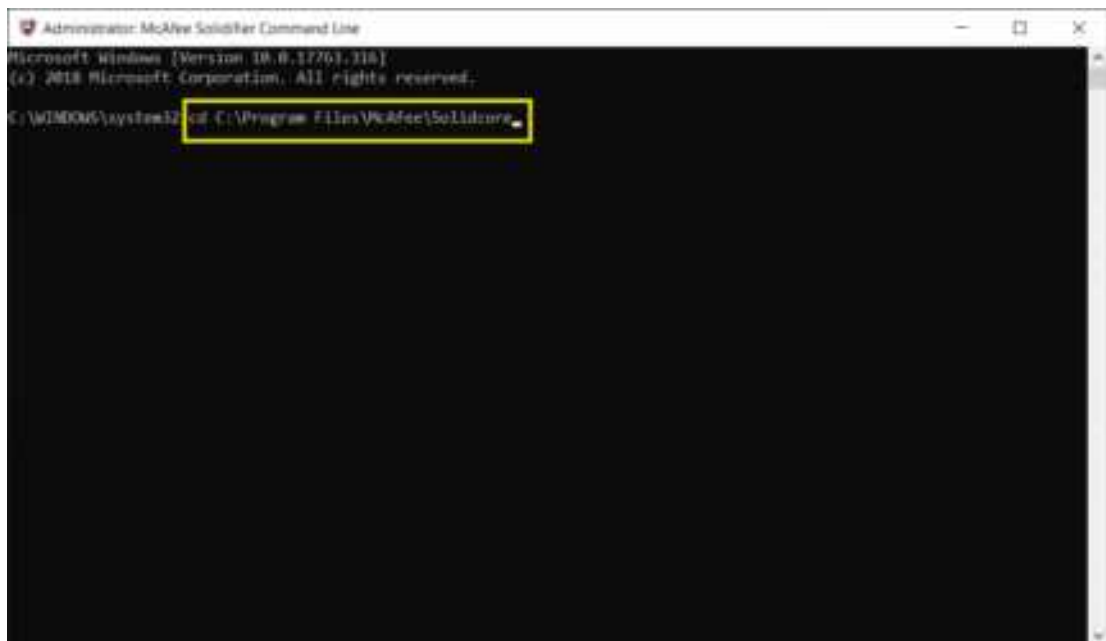
- 1 Copy the certificate *BEC.cer* from the CytExpert software disk into your instrument PC.



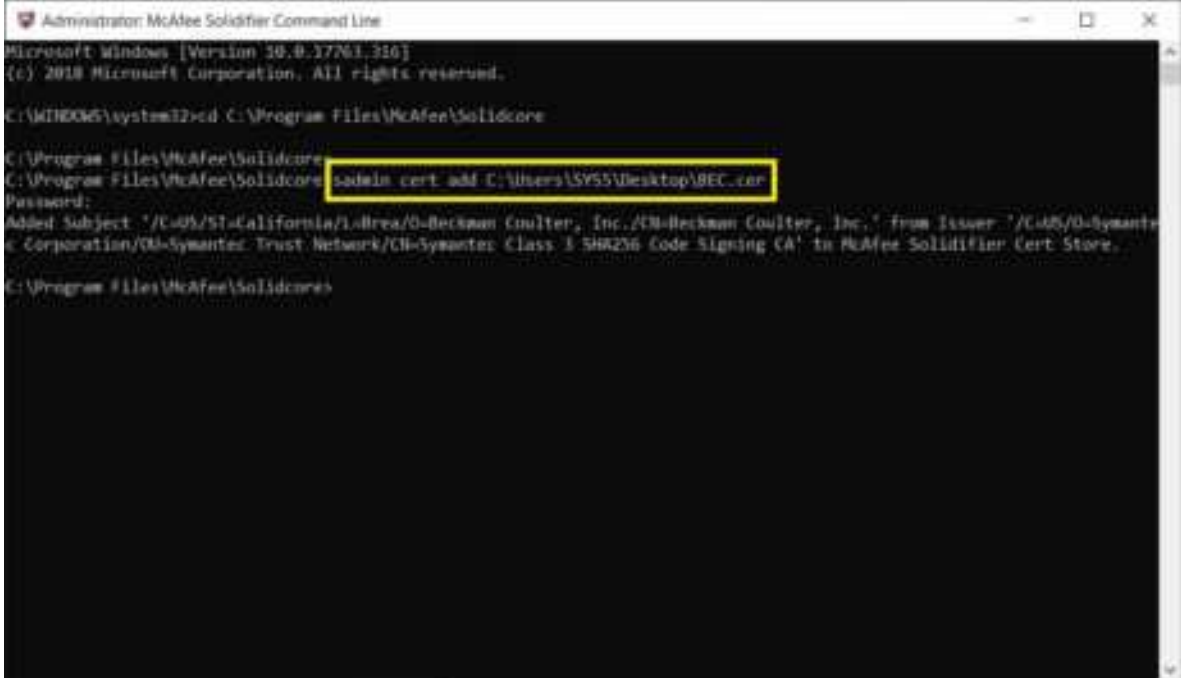
- Right-click  on your desktop, and select **Run as administrator**. The following window displays.



- Enter `cd C:\Program Files\McAfee\Solidcore`.



- 4 Enter `sadmin cert add C:\BEC.cer` to add the certificate.




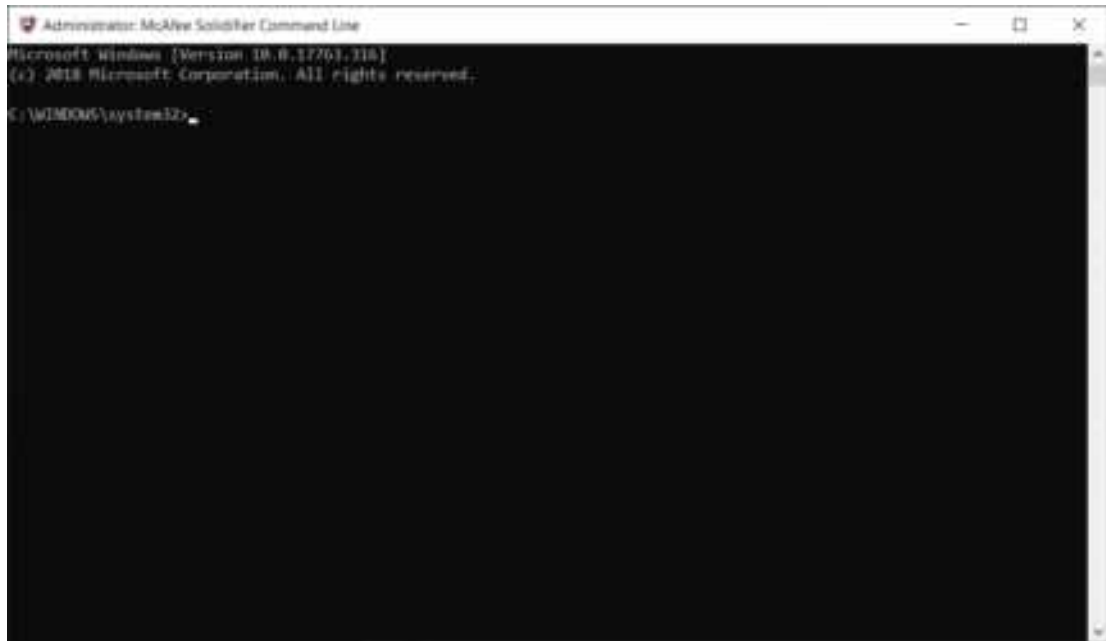
```
Administration: McAfee Solidifier Command Line
Microsoft Windows [Version 10.0.17761.316]
(c) 2018 Microsoft Corporation. All rights reserved.

C:\WINDOWS\system32>cd C:\Program Files\McAfee\Solidifier
C:\Program Files\McAfee\Solidifier>
C:\Program Files\McAfee\Solidifier> sadmin cert add C:\Users\SY55\Desktop\BEC.cer
Password:
Added Subject 'C:\OS\51-California\1\Area\0-Beckman Coulter, Inc./0-Beckman Coulter, Inc.' from Issuer 'C:\OS\0-Symantec
 Corporation\00-Symantec Trust Network\01-Symantec Class 3 SHA256 Code Signing CA' to McAfee Solidifier Cert Store.
C:\Program Files\McAfee\Solidifier>
```

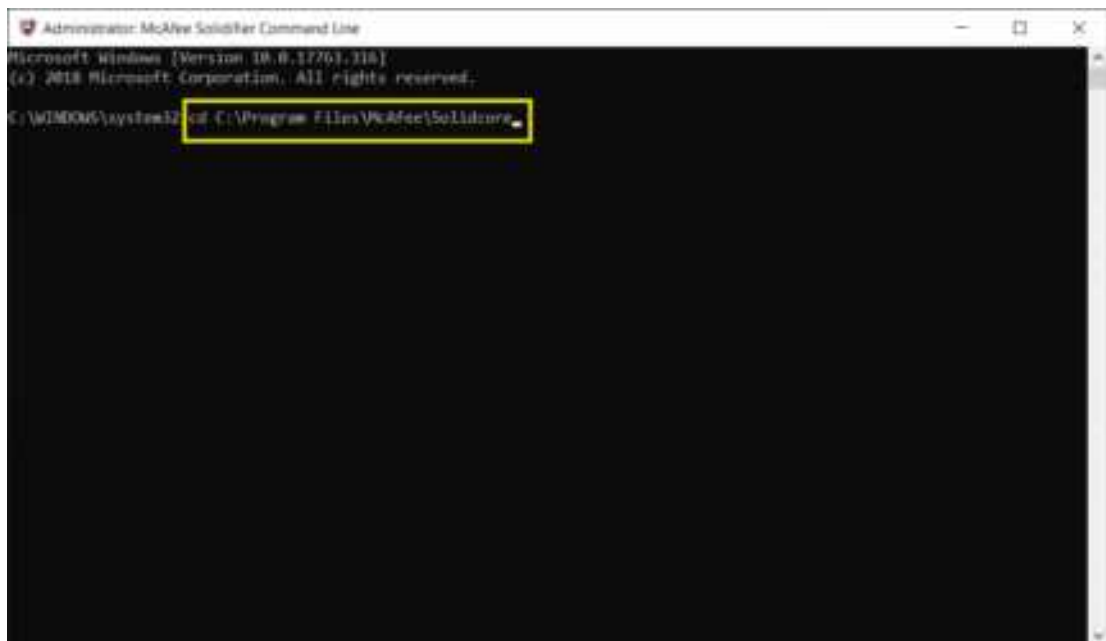
## Switching McAfee Application Control to Update Mode

The update mode allows the McAfee Application Control to scan the instrument workstation and add the newly-installed application into the white list automatically. Switch the McAfee Application Control to the update mode when you execute scheduled or emergency changes on your instrument workstation.

- 1 Right-click  on your desktop, and select **Run as administrator**. The following window displays.



- 2 Enter `cd C:\Program Files\McAfee\Solidcore`.



- 3 Enter **sadmin bu** to switch the McAfee Application Control to Update Mode.

```

Administrator: McAfee Solidifier Command Line
Microsoft Windows [Version 10.0.17763.316]
(c) 2018 Microsoft Corporation. All rights reserved.

C:\WINDOWS\system32>cd C:\Program Files\McAfee\Solidcore
C:\Program Files\McAfee\Solidcore> sadmin bu
Password:
McAfee Solidifier is entering update mode.
    
```

- 4 Execute scheduled or emergency changes, patch installations, or software updates for your instrument workstation.

- 5 Enter **sadmin eu** to exit the Update Mode.

```

Administration: McAfee Solidifier Command Line
Microsoft Windows [Version 10.0.17763.316]
(c) 2018 Microsoft Corporation. All rights reserved.


C:\WINDOWS\system32>cd C:\Program Files\McAfee\Solidcore
C:\Program Files\McAfee\Solidcore>sadmin bu
Password:
McAfee Solidifier is entering update mode.
C:\Program Files\McAfee\Solidcore> sadmin eu
Password:
McAfee Solidifier exiting from update mode.
C:\Program Files\McAfee\Solidcore>
    
```

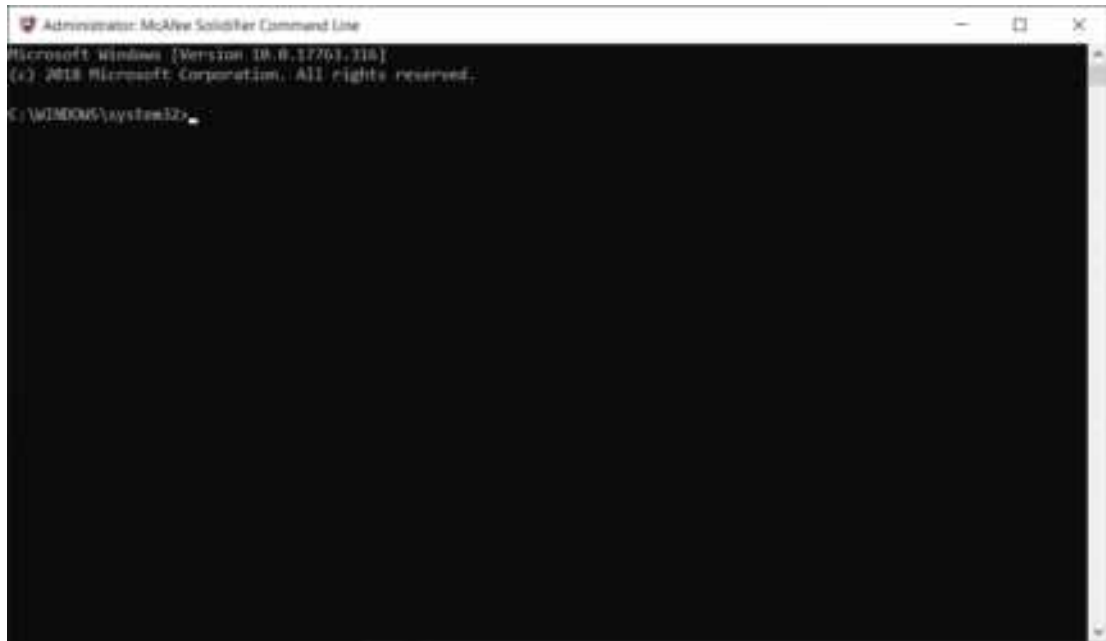
## Disabling McAfee Application Control

**IMPORTANT** Disabling McAfee Application Control is a temporary method in special cases, for example, Windows or firmware changes. This will help stop McAfee Application Control from blocking unauthorized applications. Beckman Coulter recommends enabling the McAfee Application Control in most cases.

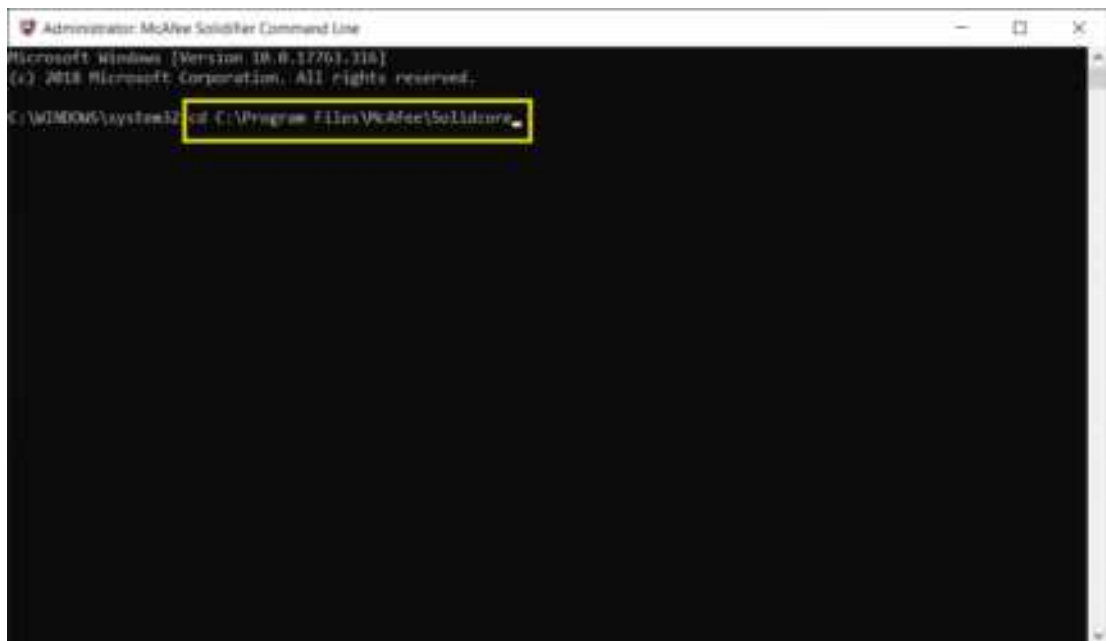
All the applications installed in this mode will not be included in the McAfee white list.



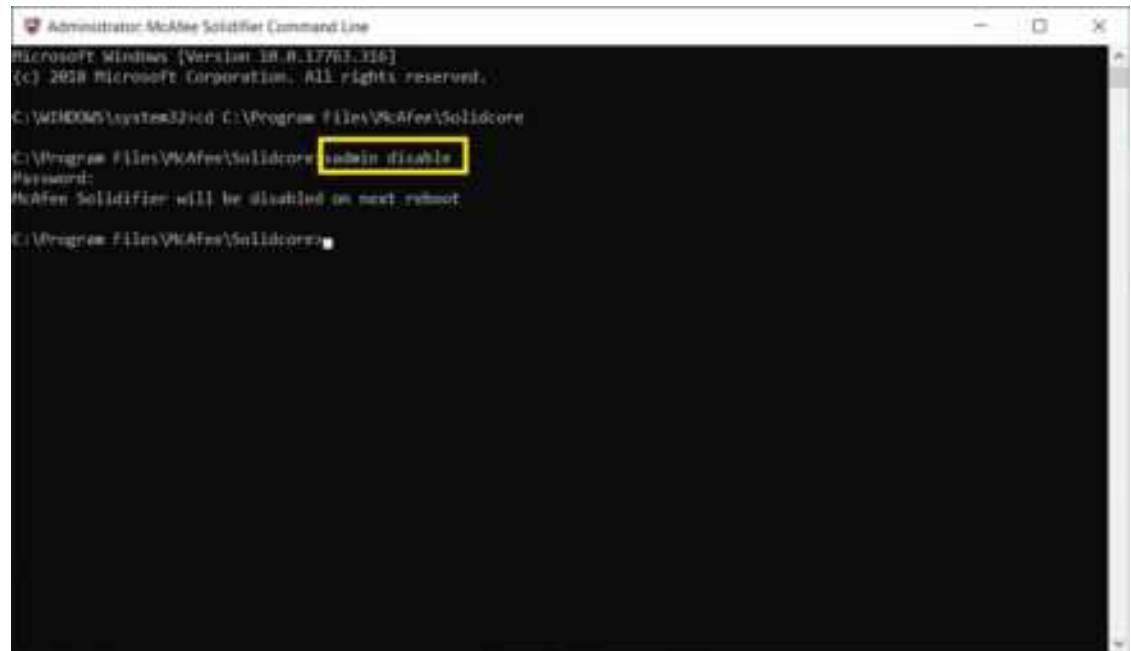
- 1 Right-click  on your desktop, and select **Run as administrator**. The following window displays.



- 2 Enter `cd C:\Program Files\McAfee\Solidcore`.



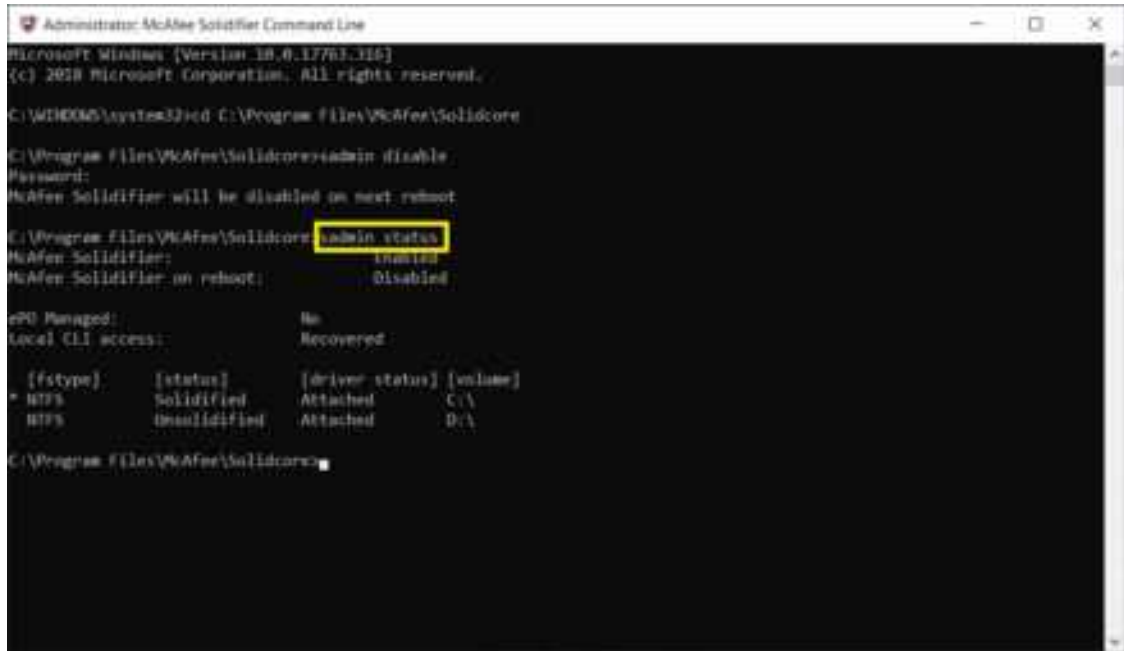
- 
- 3 Enter **sadmin disable** in the console.



- 
- 4 Select **Enter**.

- 
- 5 Restart the System.

6 Enter **admin status** to view the status of McAfee Application Control.



```
Administrator: McAfee Solidifier Command Line
Microsoft Windows [Version 10.0.17763.316]
(c) 2018 Microsoft Corporation. All rights reserved.

C:\WINDOWS\system32>cd C:\Program Files\McAfee\Solidcore

C:\Program Files\McAfee\Solidcore>admin disable
Password:
McAfee Solidifier will be disabled on next reboot.

C:\Program Files\McAfee\Solidcore>admin status
McAfee Solidifier:          Enabled
McAfee Solidifier on reboot: Disabled

ePO Managed:                No
Local CLI access:           Recovered

  [fstype]  [status]  [drive status] [volume]
* HFS      Solidified  Attached       C:\
  HFS      Unsolidified  Attached       D:\

C:\Program Files\McAfee\Solidcore>
```

## Operating System Updates

---



### WARNING

**Risk of software incompatibility. Only operating system updates posted to the Beckman Coulter website should be installed on the instrument controller PC. Do not install patches from any other source.**

**Install the update on one instrument and verify functionality before installing on other instruments.**

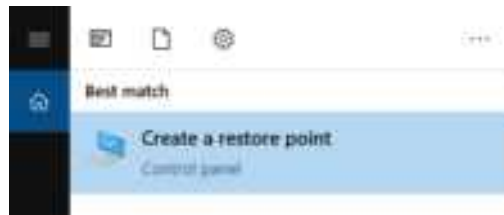
**IMPORTANT** For information on the currently supported Windows build and security updates, consult the Release Notes of the latest validated update posted to the website (see [Downloading Operating System Updates](#) for details).

**IMPORTANT** Before installing the operating system updates, ensure you have a recent backup of the instrument database and experiment files, refer to [CHAPTER 10, Backup and Restore](#), and the current BitLocker key, refer [Backing Up Your Recovery Key](#). Ensure the backups are saved to an encrypted external media or secured network drive.

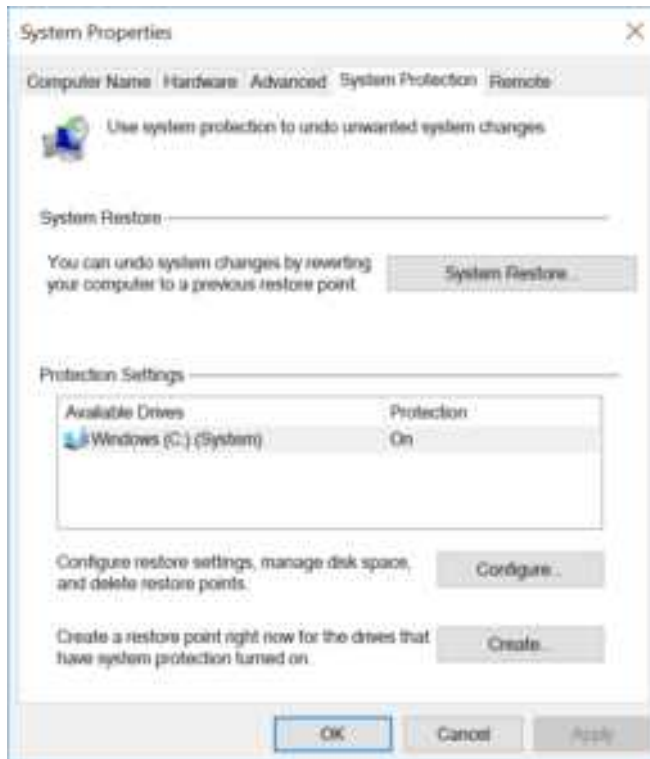
## Enabling System Protection

---

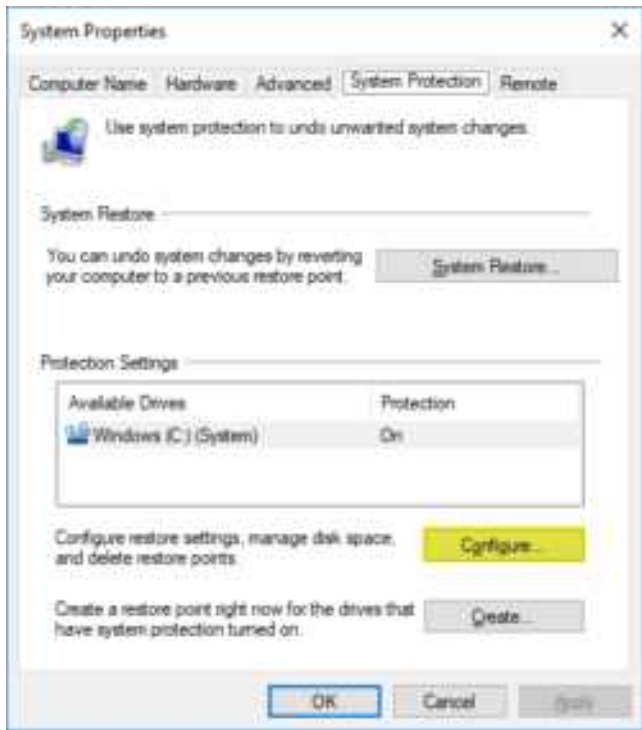
- 1 In the Start Menu, type **Restore** to locate the **Create a Restore Point**.



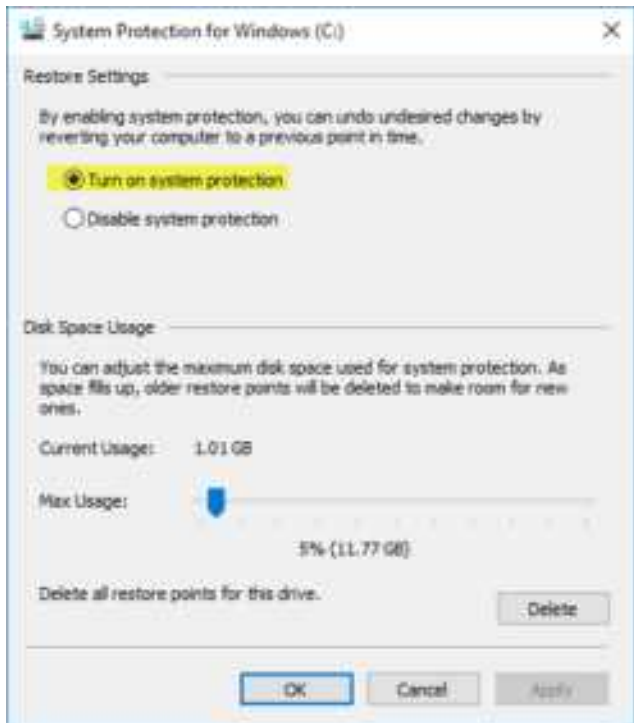
2 Double-click **Create a Restore Point** to open the System Properties window.



3 Select **Configure**.



The following window appears.



- 
- 4 Select **Turn on system protection**, then select **Apply**.
- 
- 5 Close the System Properties window by selecting **OK**.
- 

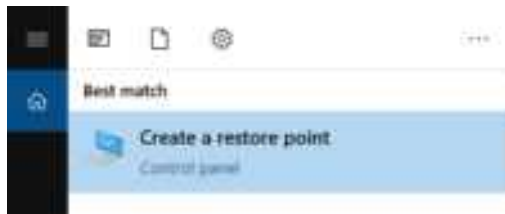
## Creating a Restore Point

A restore point is used to remove all software and update installations that occurred after it was created. If installing an update on your PC causes any loss of functionality, the restore point can be used to place the system back into the operable state present before the update installation. In all cases, a system restore with any restore point would not cause loss of any data (i.e. LMD files) on the system.

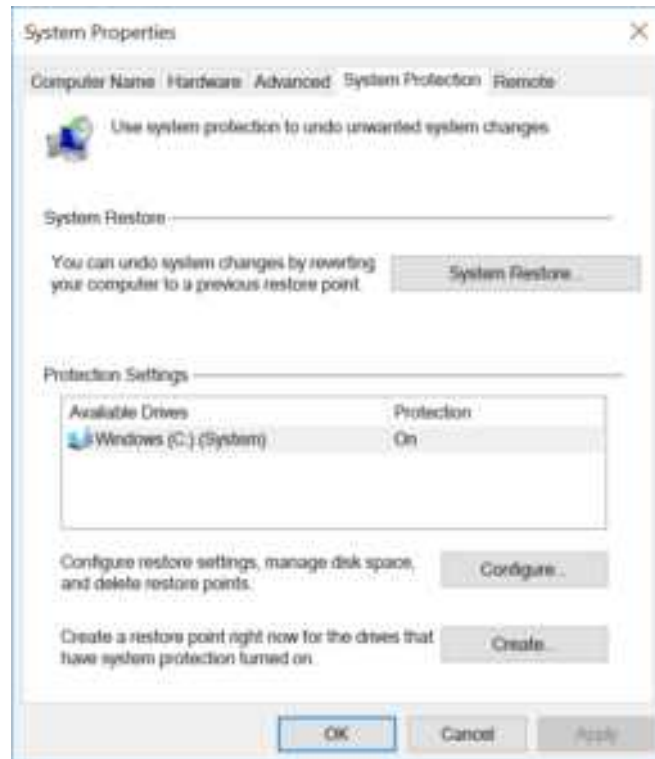
### CAUTION

**Risk of unexpected software modification. To ensure a system recovery point is available that is indicative of the most recent software configuration, the user should create a system restore point immediately prior to running the operating system update installer. Otherwise, a user would need to utilize the most recent automatically created restore point which might be up to 72 hours old and not include all recent software modifications.**

- 
- 1 In the Start Menu, type **Restore** to locate the **Create a Restore Point**.



- 2 Double-click **Create a Restore Point** to open the System Properties window.



- 3 Type a name for the restore point and select **Create**.
- 4 Wait for the restore point creation to complete and then select **Close**.
- 5 Close the System Properties window by selecting **OK**.

## Downloading Operating System Updates

In order to download and install operating system updates, you will need to access the Beckman Coulter website at [www.beckmancoulter.com](http://www.beckmancoulter.com).

**IMPORTANT** Account registration is required for new users.

- 1 Go to [www.beckmancoulter.com](http://www.beckmancoulter.com).

---

2 Using the menu bar in the in the upper right hand corner of the screen, hover over **Login**, then scroll down to select **Software Downloads**.

---

3 To search by product:

- a. Select **Research & Discovery** from the Market Segment drop-down menu.
- b. Select **Flow Cytometry** from the Product Line. drop-down menu.
- c. Select **Instruments** from the Product Series drop-down menu.
- d. Select **CytoFLEX** from the Product drop-down menu.

---

4 Select **Search**.

---

**IMPORTANT** Print out the Release Notes for each update as they will not be available when the next update is released. The Component Name section of the release notes identifies the Microsoft updates that are included in the download. This information may be requested by your IT team and will be needed to recover from a failed update.

5 Each operating system update is cumulative and only the most recent validated set of updates will be available for download. Select the first file in the results to view the release notes and then select **Download**.

If more than one update is listed in the search results, select **Back**, and repeat this step for each update.

If the operating system updates cannot be not downloaded directly to the instrument controller system, transfer the downloaded files via an encrypted external media or secured network drive to the instrument controller PC.

---

## Notification Options

To receive notification when a new operating system update is validated and available for download, you must sign up for an account on [www.beckmancoulter.com](http://www.beckmancoulter.com) and follow the procedure for setting up subscriptions.

Sign up for subscriptions as outlined below:

- Select the **Document Language** consistent with your IFU language.
- Select **Research & Discovery** from Market Segment.
- Select **Flow Cytometry** from Product Line.
- Select **Instruments** from Product Series.
- Select **CytoFLEX** from Product.

If you do not sign up for product notifications, you will have to check periodically for newly released operating system updates, see [Downloading Operating System Updates](#).

## Installing the Operating System Updates

 **CAUTION**

**Risk of software incompatibility. Beckman Coulter can only support operating system updates on unmodified systems. Application of domain policies or other configuration changes may impact compatibility.**

**IMPORTANT** If more than one update is available for your product, install the updates in the order indicated by the sequence number as outlined in the file naming convention below.

RSU-<Operating System> <Product Name>-<Year><Month>\_<Sequence #>\_<Sequence Revision#>

**Example:** RSU-W10-CytoExpert-2021Sep\_1\_0

- 
- 1** Ensure you have a recent copy of your BitLocker key, refer to [Backing Up Your Recovery Key](#).

---

  - 2** Login to Windows as a user with Administrator access.

---

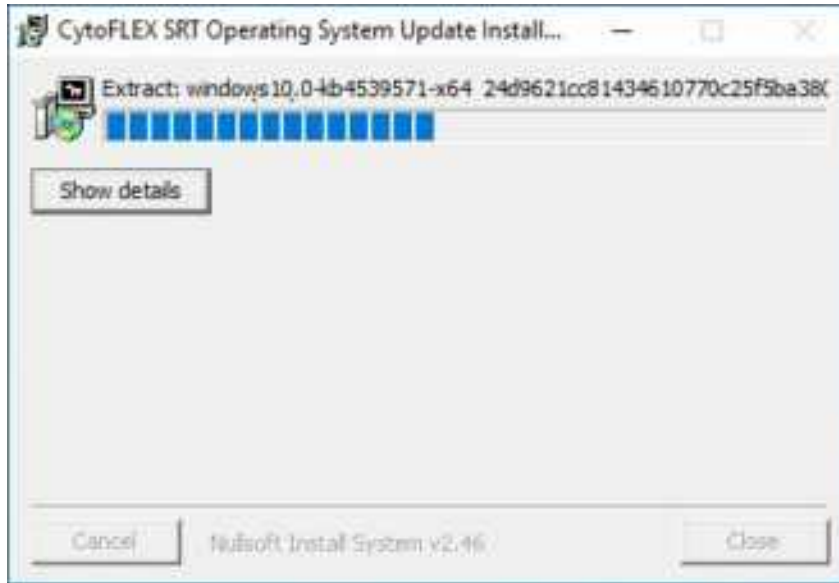
  - 3** Close all program and save open files.

---

  - 4** Power down the instrument.

- 5 Open the first operating system update file (For example: RSU-W10LTSC-CytoFLEX-2020Jun\_1\_0) on the Instrument Controller PC by double-clicking on the file. If the Microsoft Windows Defender Smart Screen prompt appears, select **More Info** and **Run Anyway** to launch the installer. This process may take several minutes. See [Figure G.6](#).

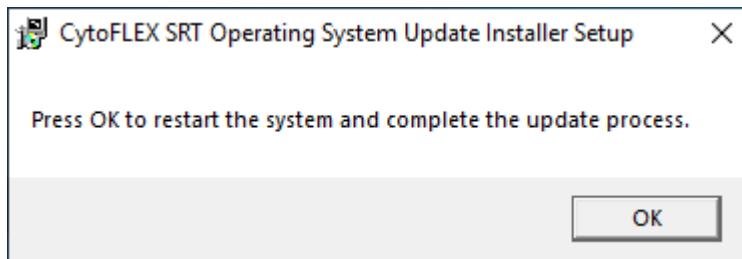
**Figure G.6** Security Update Setup Installing



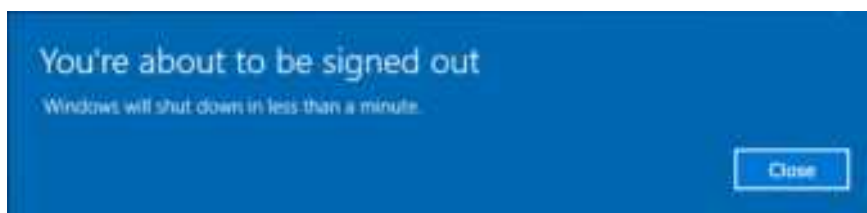
**NOTE** The security update installer will automatically detect and install only the necessary updates.

- 6 Once the operating system update setup has completed, select **OK** to restart the system and complete the update process. See [Figure G.7](#) and [Figure G.8](#).

**Figure G.7** Security Update Setup Successfully Installed

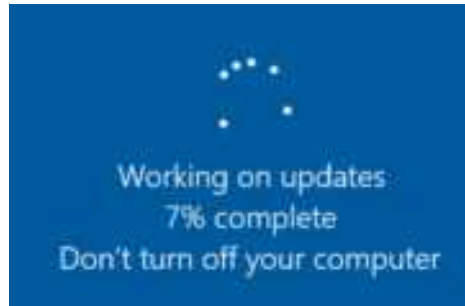


**Figure G.8** Windows Shutdown



- 
- 7 Wait while the system completes the installation of the security updates. This process may take several minutes and will return you to the Windows login screen. See [Figure G.9](#).

**Figure G.9** Working on Completing Security Updates



- 
- 8 Install any additional downloaded operating system updates (sequence numbers above 1) by repeating Steps 4 to 6.
  - 9 Verify functionality of instrument software before installing operating system updates on any other system. If functionality is impaired, see [Recovering from Failed Operating System Updates](#).
- 

## Recovering from Failed Operating System Updates

These steps below should only be followed if the instrument software or operating system functionality is impaired after an operating system update was applied.

- 
- 1 Power down the instrument and close all programs. Do not turn your workstation off.
  - 2 In the start menu, type view update and select **View your Update History**.
  - 3 Select **Uninstall Updates**.
  - 4 Highlight the update listed under Microsoft Windows that matches the cumulative security update KB number in the release notes. Refer to Component Name section of the Release Notes, see Step 5, [Downloading Operating System Updates](#).
  - 5 Select **Uninstall** and select **Yes** when prompted to verify the uninstall. This process may take several minutes to complete.

- 
- 6 When prompted to restart, select **Restart Now**.

---

  - 7 Once the PC has been rebooted, login and verify Microsoft update has been removed by repeating Steps 2 and 3. Verify the KB selected in Step 4 is no longer listed.

---

  - 8 Power on the instrument and verify restored software functionality.
    - If software functionality has been restored, continue using your instrument without the update installed. [Contact us](#) for troubleshooting the update incompatibility.
    - If software functionality has not been restored and the PC was not provided by Beckman Coulter, contact laboratory IT for system restore options.
    - If software functionality has not been restored and the PC was provided by Beckman Coulter, [contact us](#) for system restore.
- 

## System Hardening

---

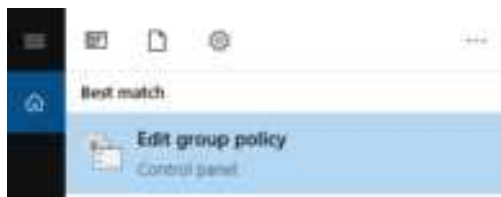
### Enabling Automatic Log-Off

**IMPORTANT** Automatic log-Off can protect your instrument PC from unauthorized operation when you leave the PC temporarily. Follow the steps below to enable the Screen Saver protection.

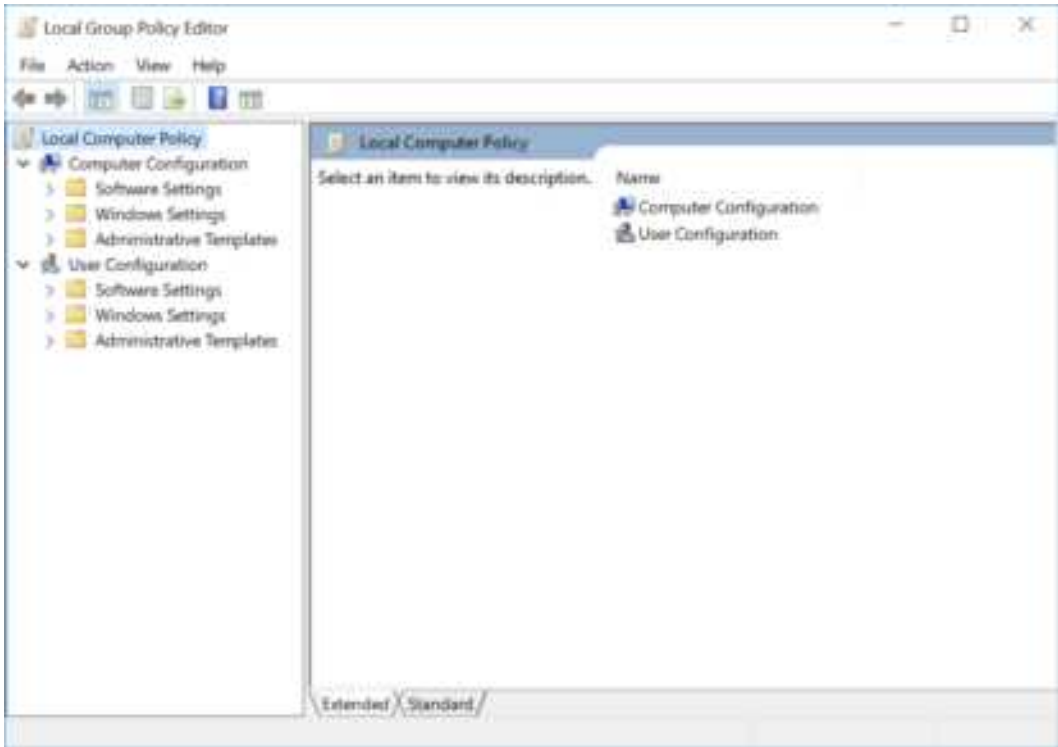
#### Enabling Screen Saver Protection

---

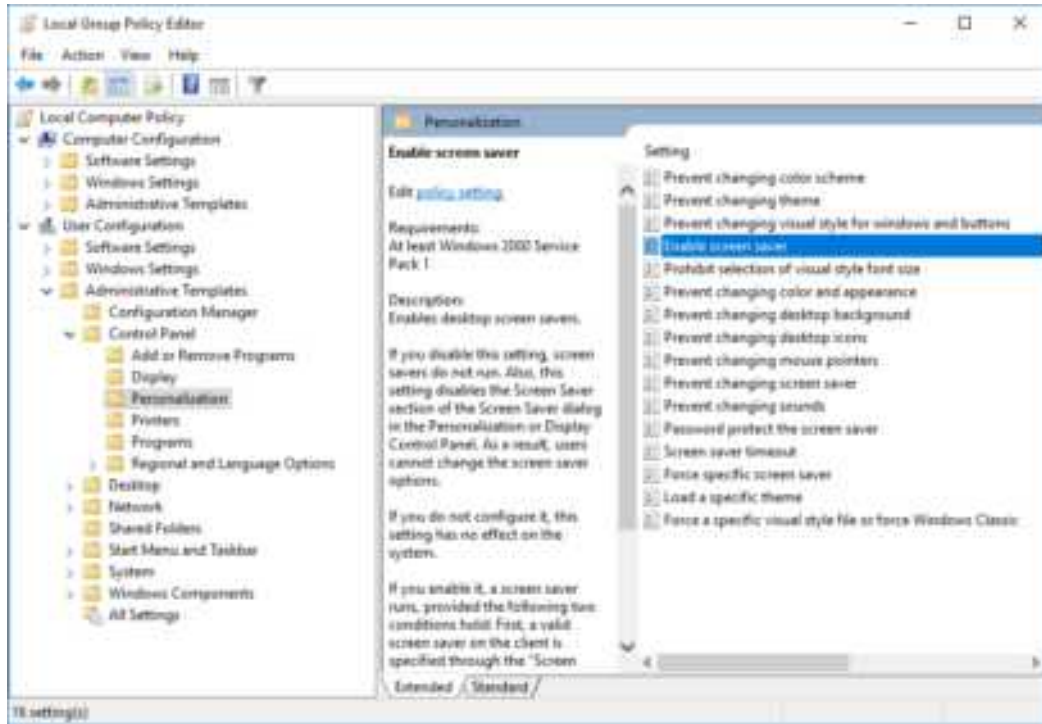
- 1 Type **Edit group policy** from the Windows search bar to locate the Edit group policy editor.



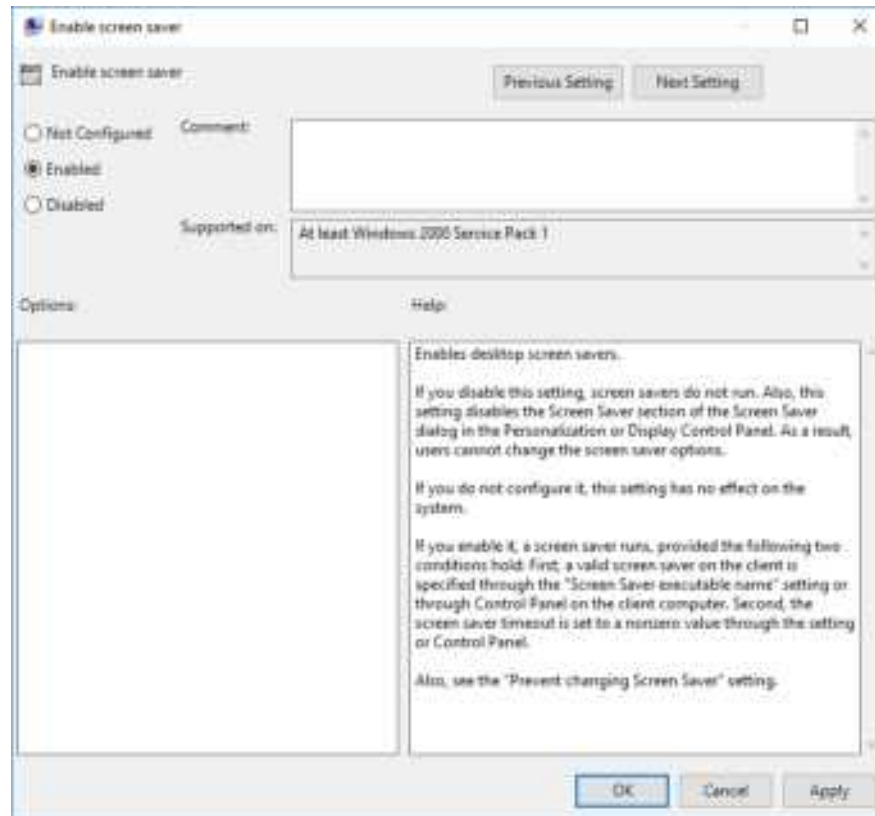
2 Select **Edit group policy**. The Local Group Policy Editor window displays.



3 Navigate to **User Configuration > Administrative Templates > Control Panel > Personalization**.

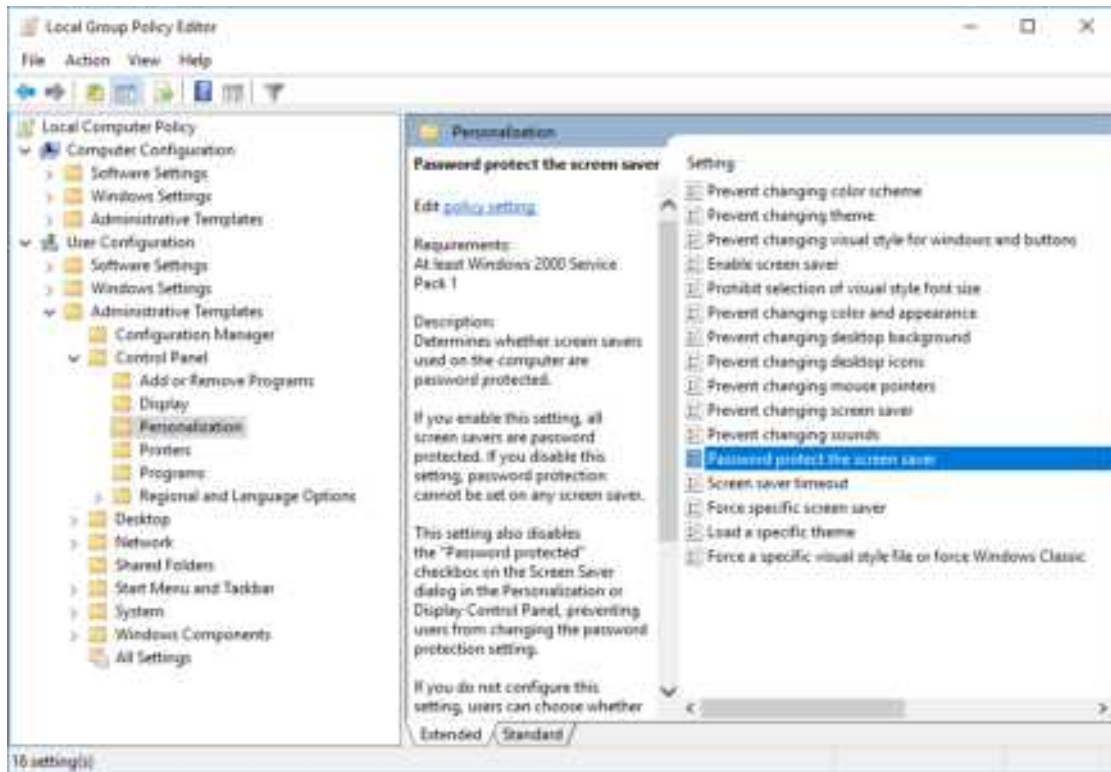


- 4 Select **Enable screen saver**. The following window appears.

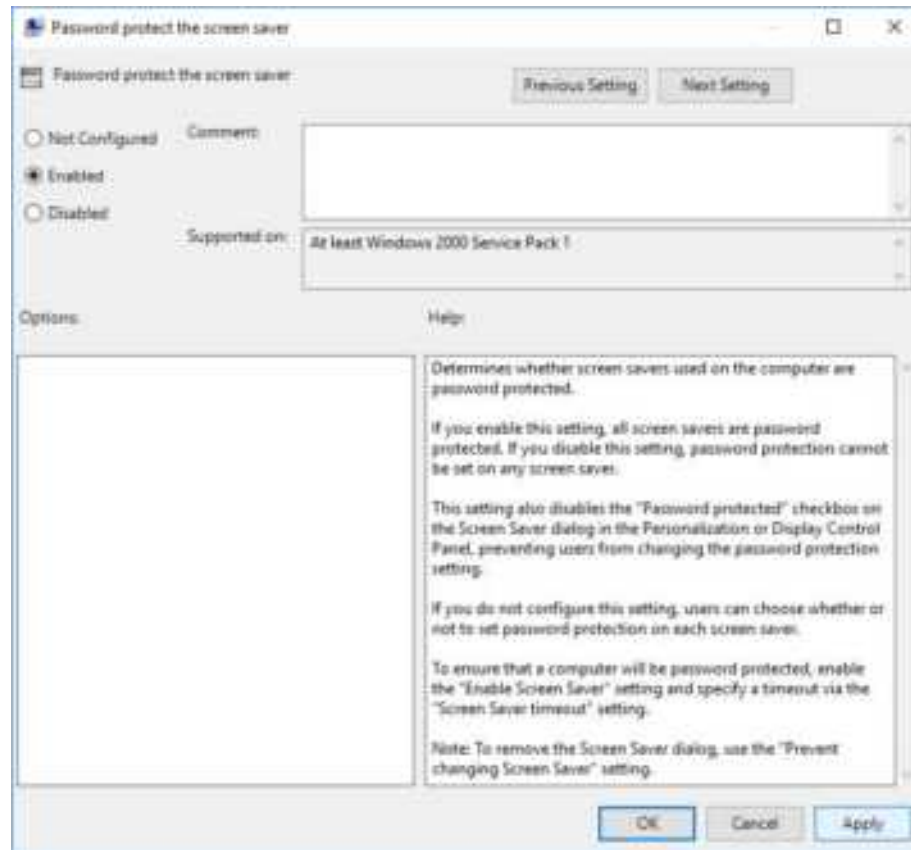


- 5 Select **Enabled** and **Apply**.
- 6 Select **OK** to close the Enable screen saver window.

7 Select **Password protect the screen saver** from the Local Group Policy Editor window.

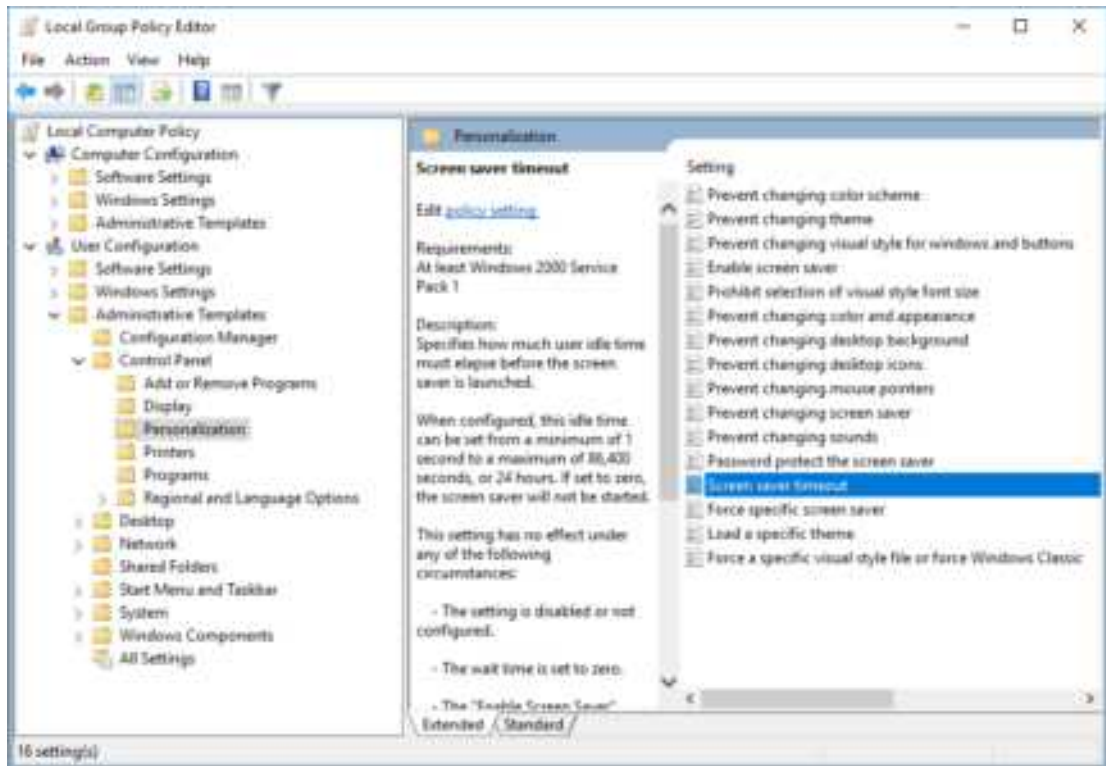


8 Select **Enabled** and **Apply**.

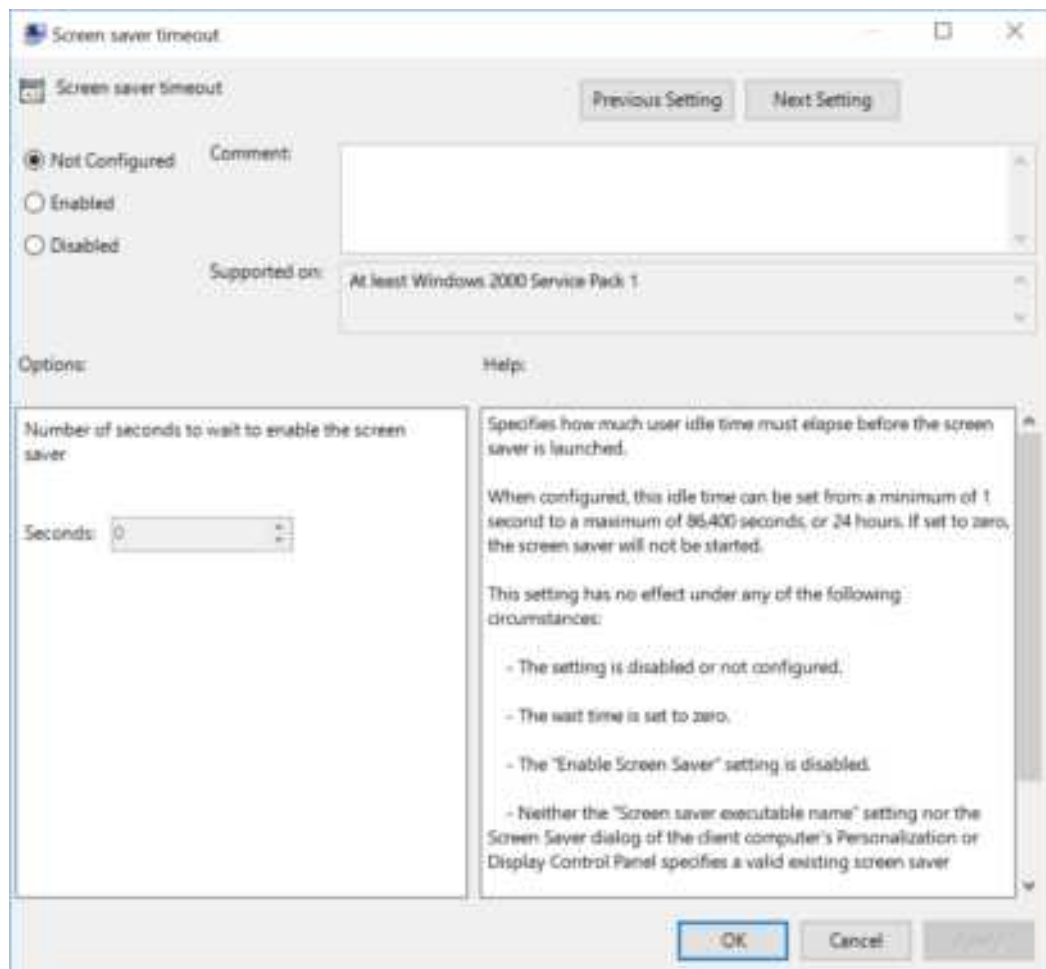


9 Select **OK** to close the window.

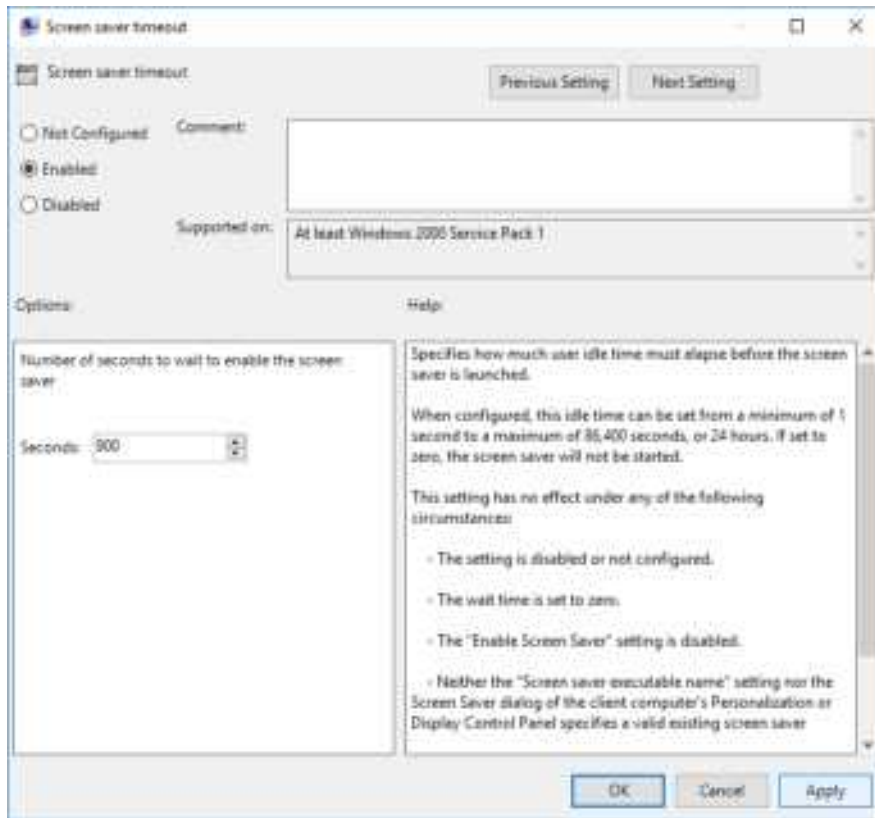
10 Select **Screen saver timeout** from the Local Group Policy Editor window.



The Screen saver timeout window appears.



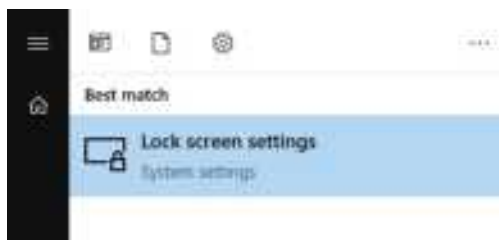
**11** Select **Enabled** and **Apply**.



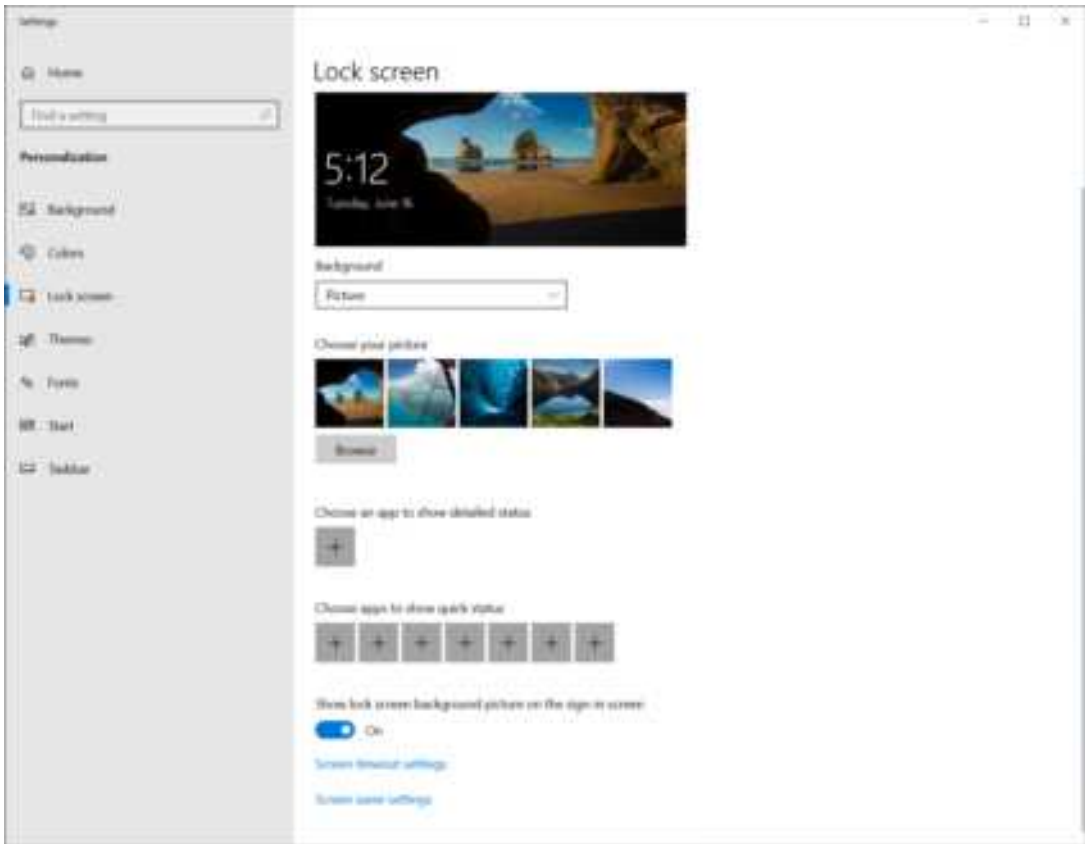
**12** Select **OK** to close the window.

**Setting Lock Screen**

**1** Type **Lock screen settings** from the Windows search bar to locate **Screen saver settings**.



The Settings window appears.



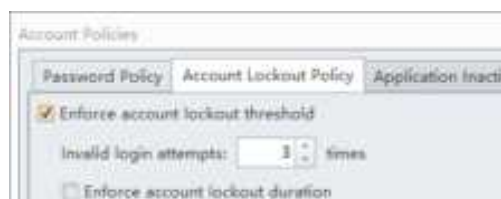
- 2 Scroll down to the bottom and select **Screen saver settings**. The Screen Saver Settings window appears.



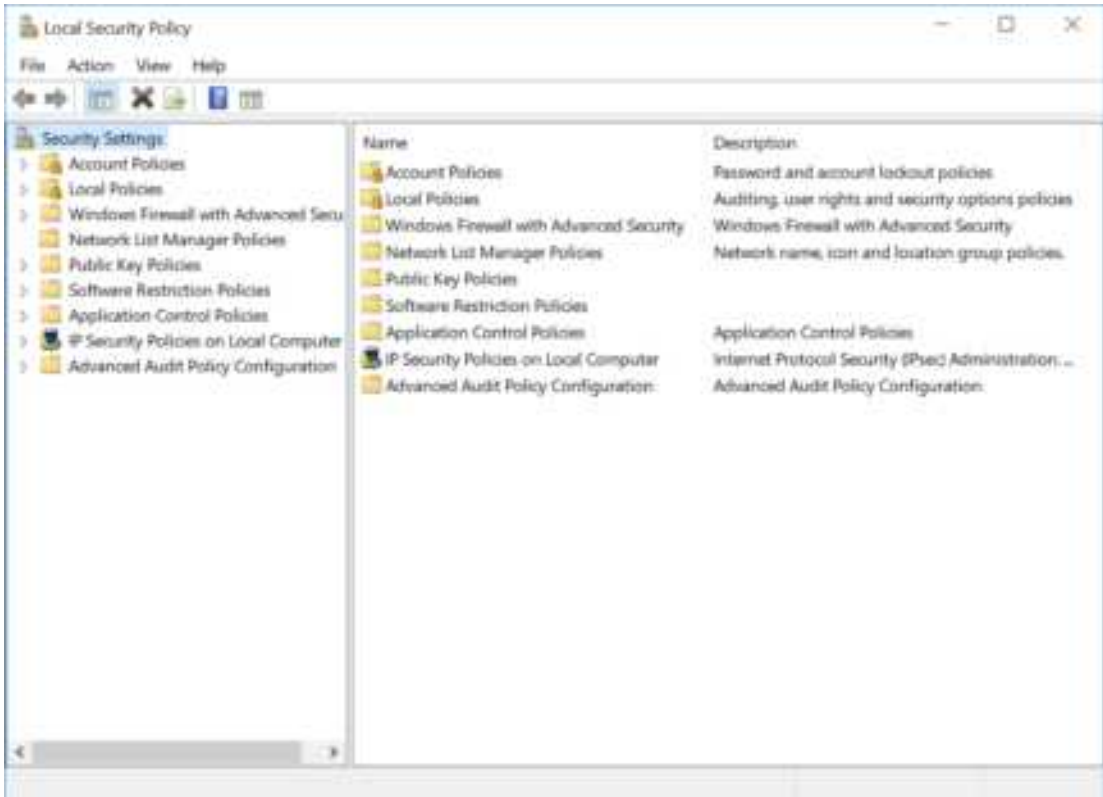
- 3 Select **Apply**.
- 4 Select **OK** to close the window.

## Setting Account Lockout Policy

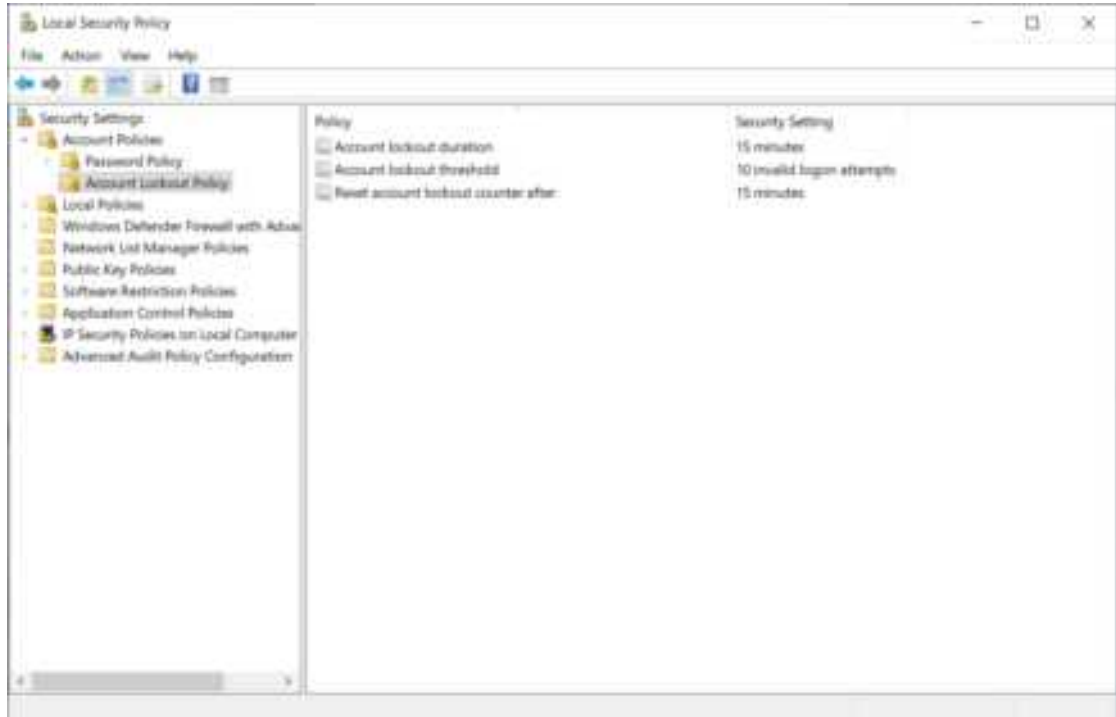
- 1 Type **Local Security Policy** from the Windows search bar to locate the **Local Security Policy**.



2 Double-click **Local Security Policy** to open the Local Security Policy window.



- 3 Navigate to **Security Setting > Account Policies > Account Lockout Policy**. Configure the Security Settings as below.

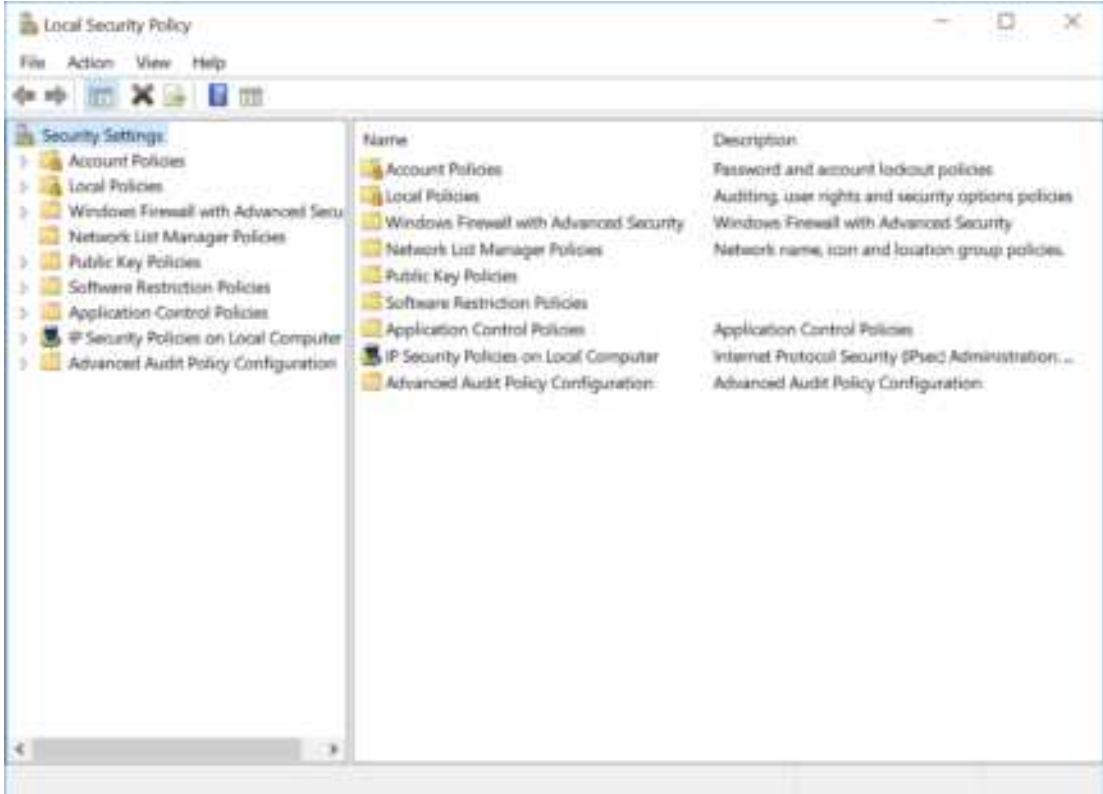


## Setting Password Policy

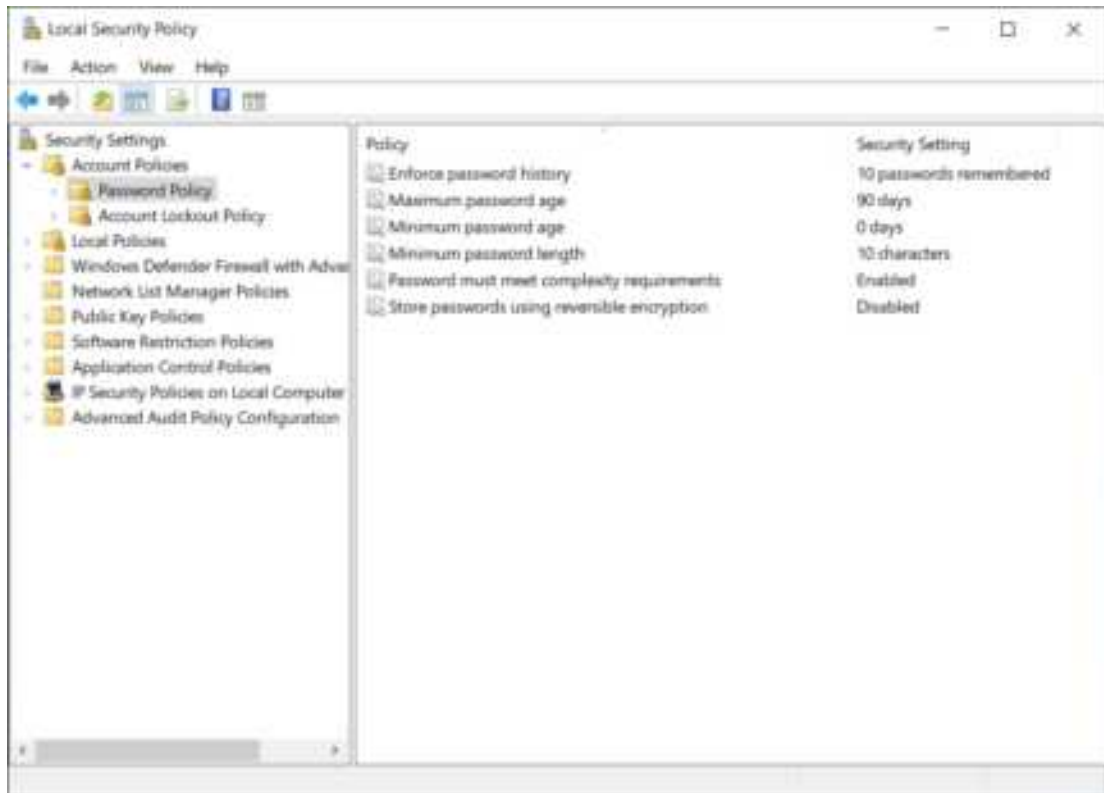
- 1 Type **Local Security Policy** from the Windows search bar to locate the **Local Security Policy**.



2 Double-click **Local Security Policy** to open the Local Security Policy window.



3 Navigate to **Security Setting > Account Policies > Password Policy**.



4 Customize the password policy according to the following.

- **Enforce password history:** 10 passwords remembered
- **Maximum password age:** 90 days
- **Minimum password age:** optional
- **Minimum password length:** 10 characters
- **Password must meet complexity requirements:** enabled

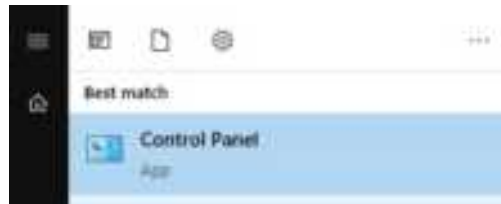
The password must contain all four of the following character types:

- letter in upper case (A -Z)
- letter in lower case (a -z)
- numbers (0-9)
- special character (i.e.,!, @, #, \$,% , ^, &)

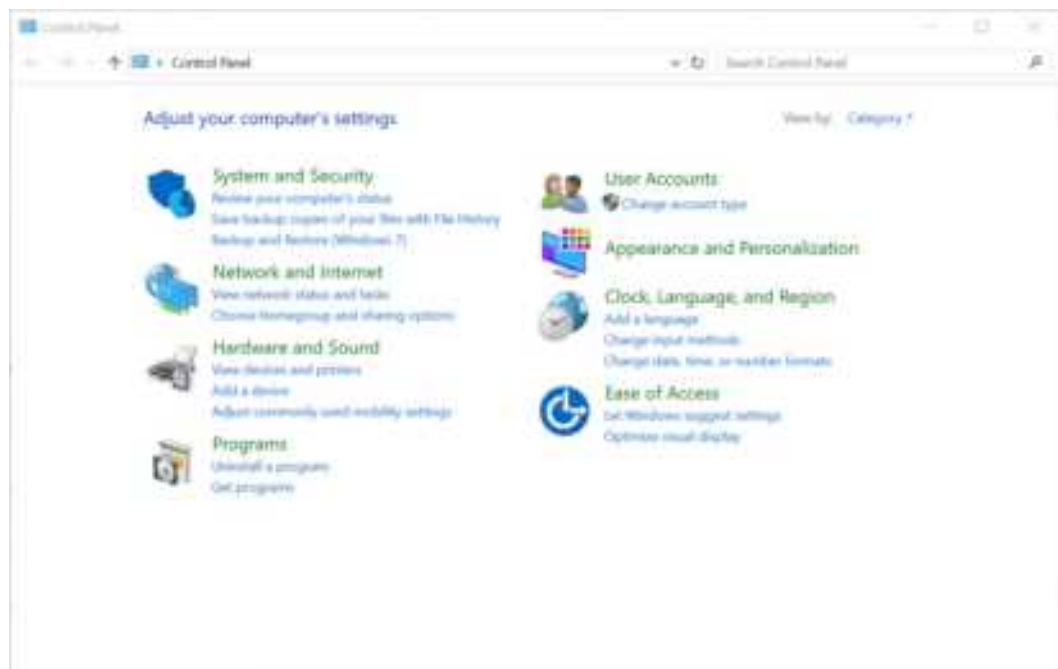
- **Store passwords using reversible encryption:** optional

## Disabling Remote Access

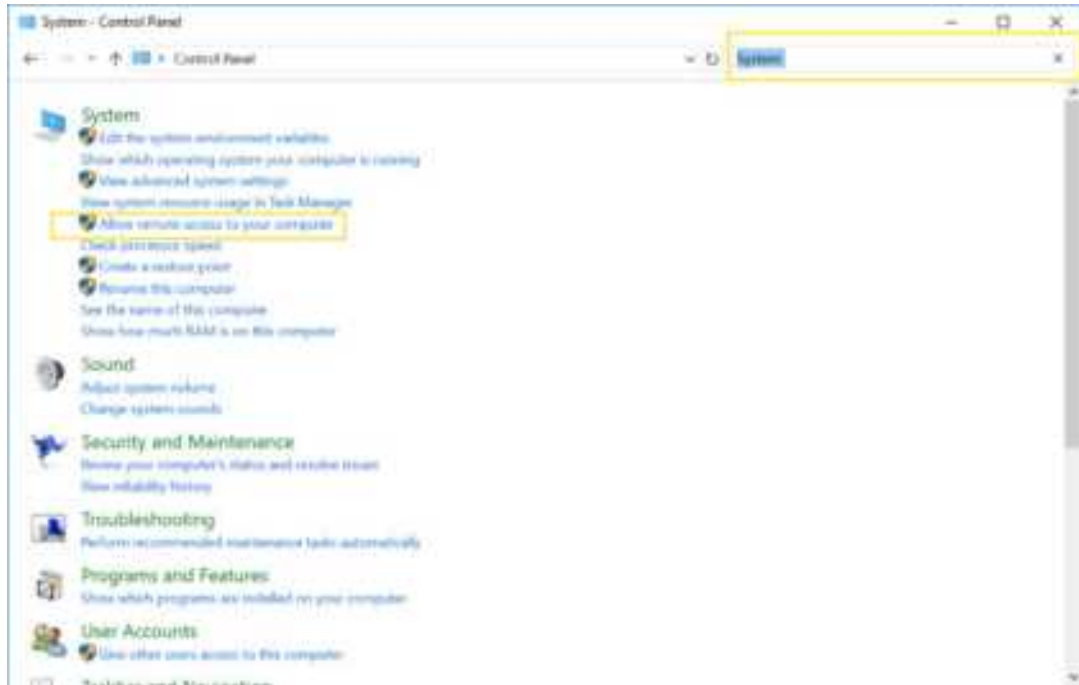
- 1 Type **Control Panel** from the Windows search bar to locate the **Control Panel** app.



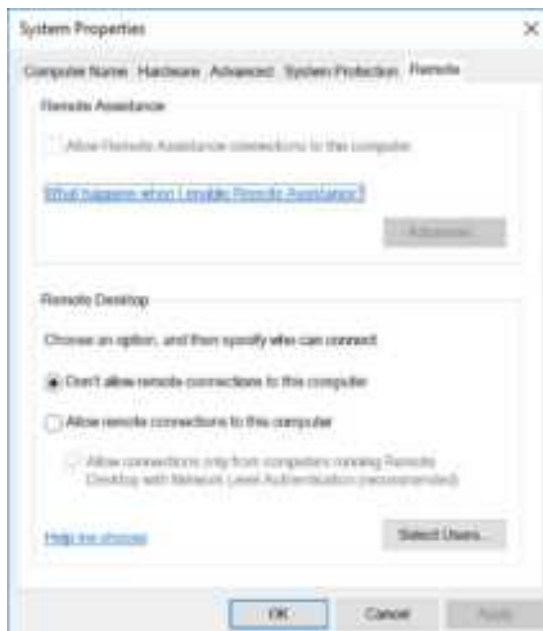
- 2 Select **Control Panel** to open the Control Panel window.



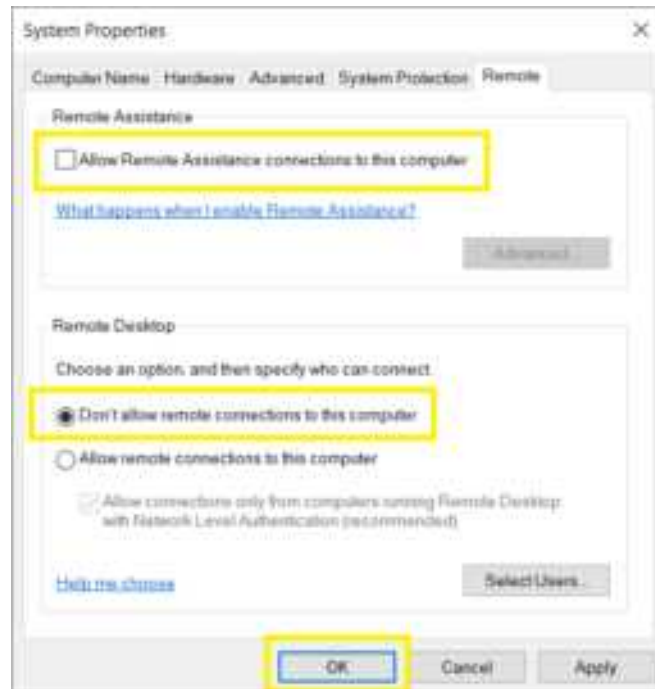
3 Type **Security** from the search bar to locate **Allow remote access to your computer**.



4 Select **Allow remote access to your computer**. The System Properties window appears.



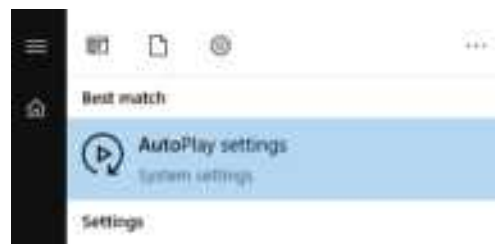
- 5 Select **Don't allow remote connections to this computer** from the Remote tab.



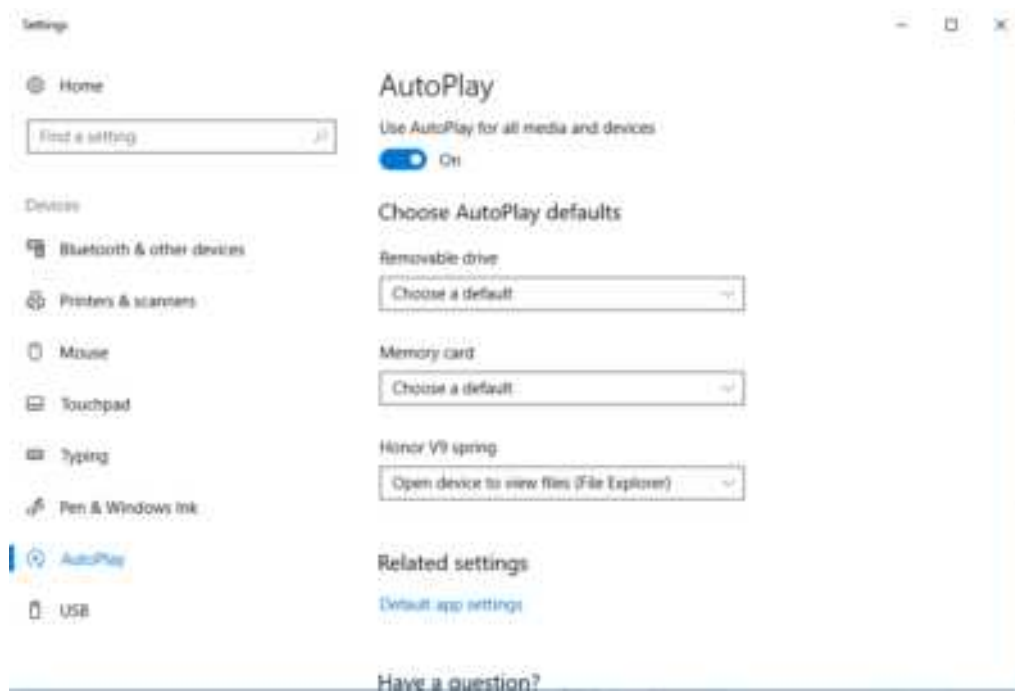
- 6 Select **OK** to close the window.

## Disabling Auto Play

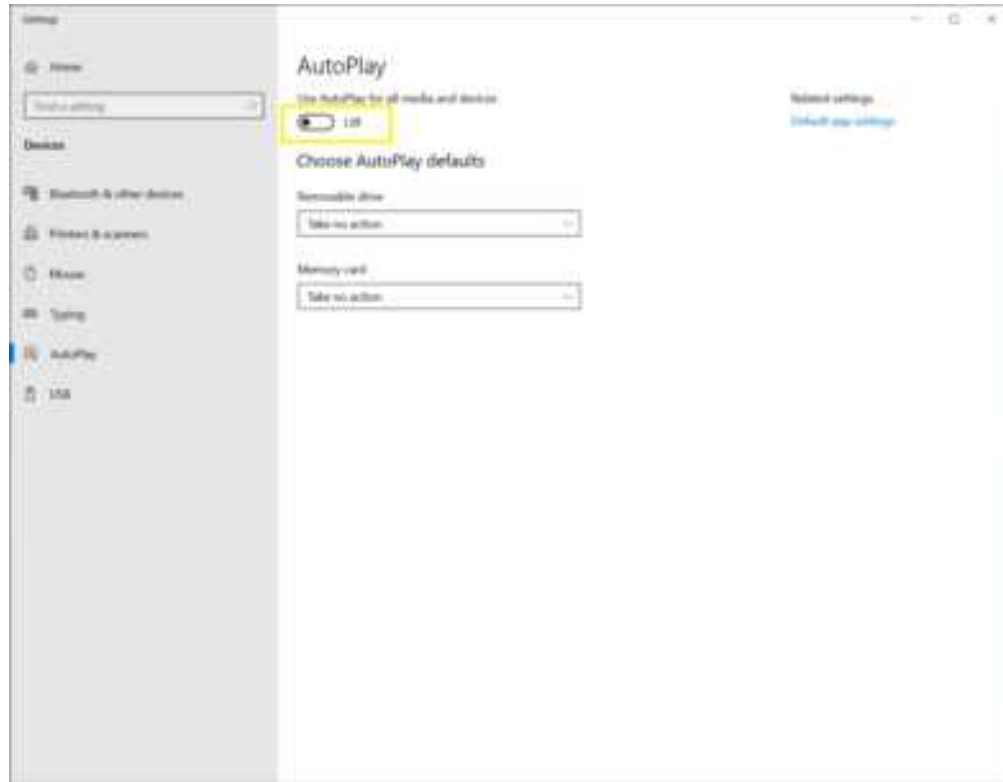
- 1 Type **Auto Play settings** from the Windows search bar to locate the **Auto Play settings**.



2 Select **Auto Play settings**. The Settings window appears.



3 Select **Off** to turn off Auto Play.



4 Close the window.

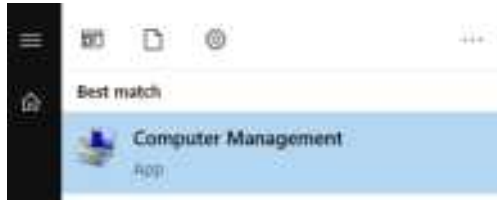
## Disabling Unnecessary Services

It is recommended to disable all the unnecessary services while operating the CytExpert software. Refer to [Table G.1](#).

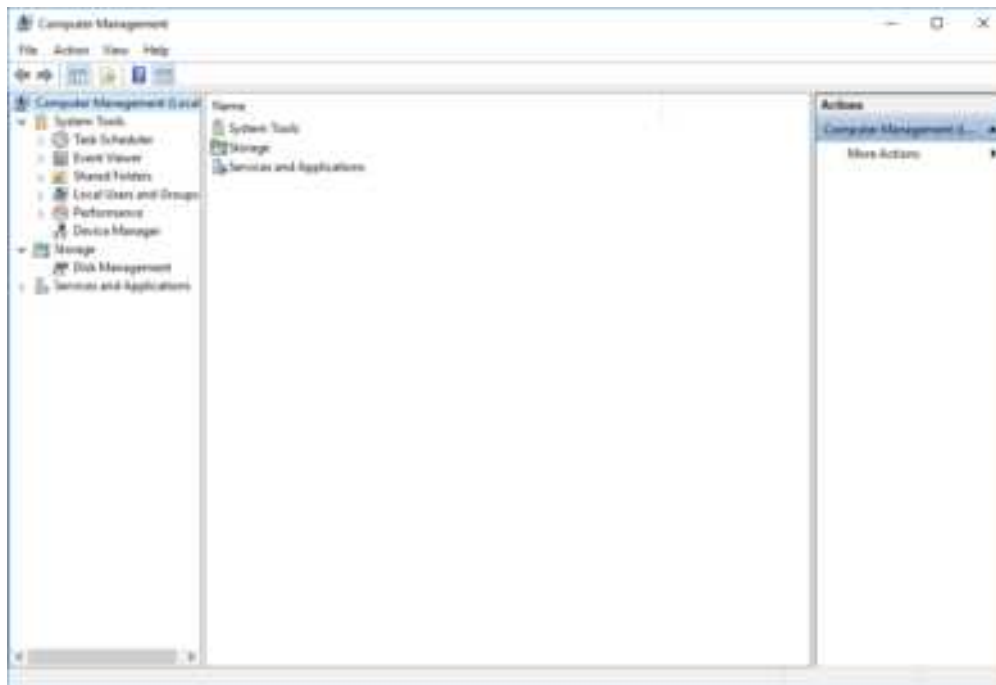
**Table G.1** List of Unnecessary Services

Bluetooth Support Service	Microsoft FTP Service (If available)	Windows Media Player Network Sharing Service
Geo-location Service	Microsoft iSCSI Initiator Service	Windows Mobile Hotspot Service
Infrared monitor service	Remote Procedure Call (RPC) Locator	WinHTTP Web Proxy Auto-Discovery Service
Internet Connection Sharing	Routing and Remote Access	Xbox Live Game Save
Link-Layer Topology Discovery Mapper	SSDP Discovery	Xbox Live Networking Service
LxssManager (If available)	UPnP Device Host	

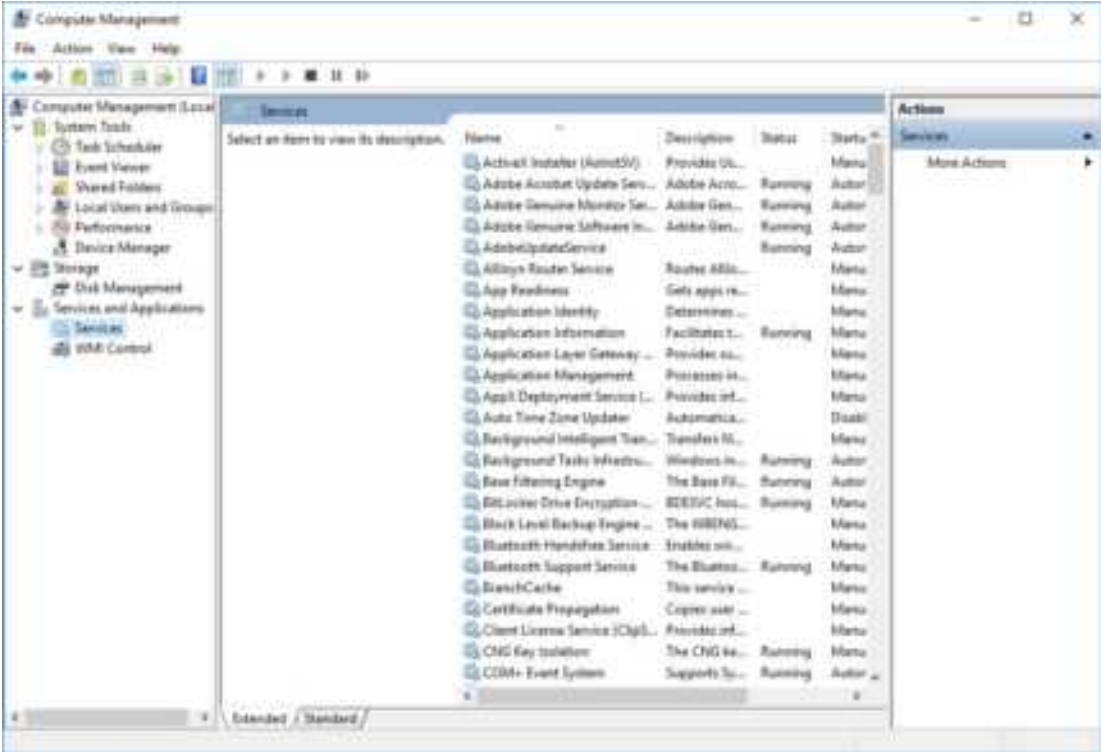
- 1 Type **Computer Management** from the Windows search bar to locate the Computer Management App.



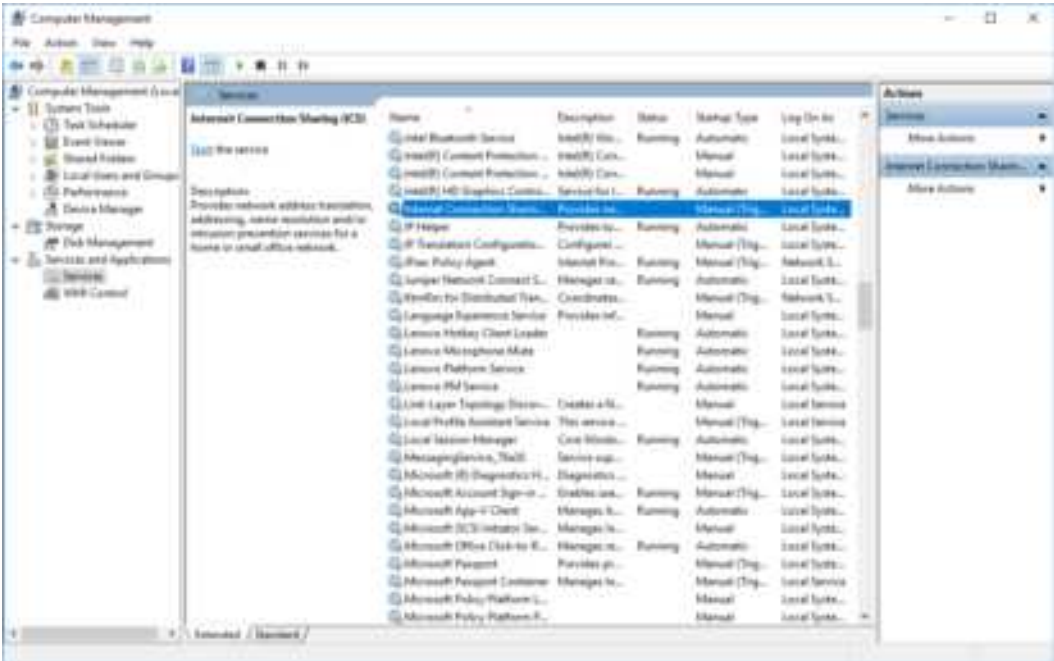
- 2 Select **Computer Management**.



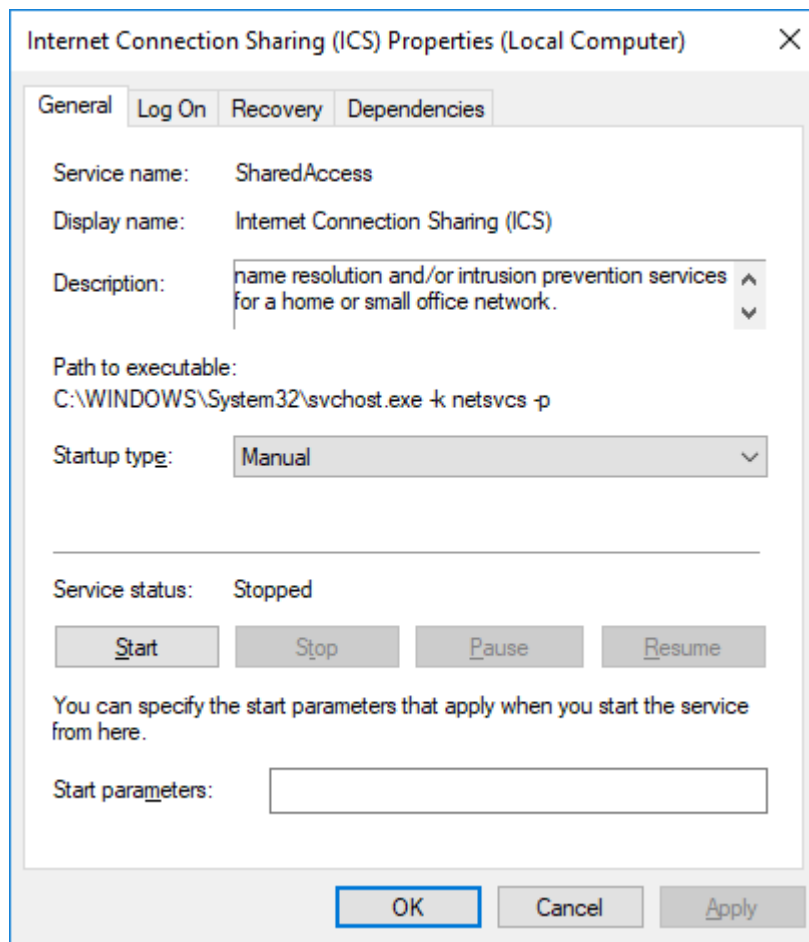
3 Navigate to **Services and Applications > Services**.



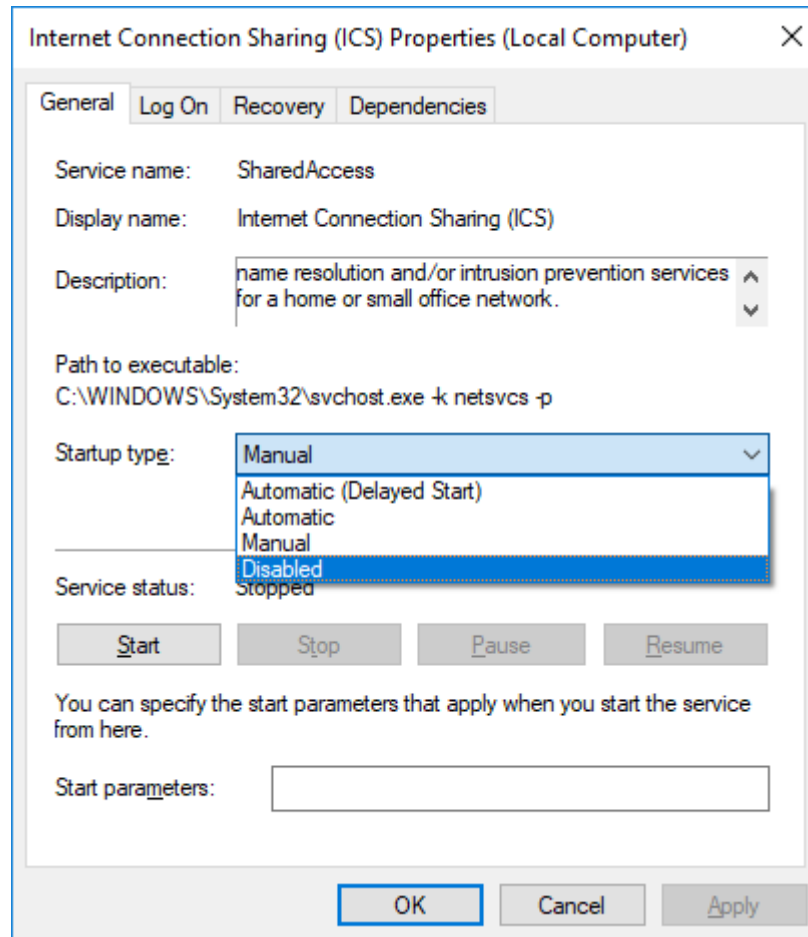
4 Select the service you want to disable.



The following window appears.



- 5 Select **Disabled** from the Startup type drop-down.

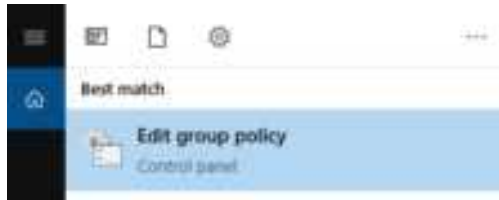


- 6 Select **Apply**.

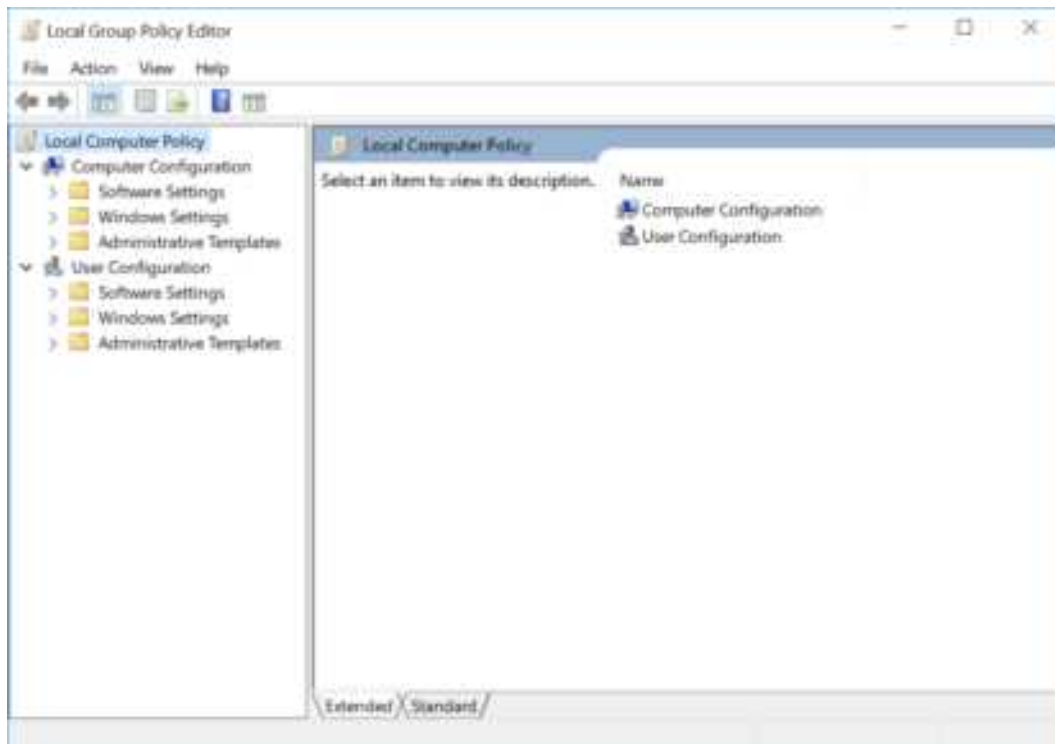
- 7 Select **OK** to close the window.

## Disabling Unauthorized Applications

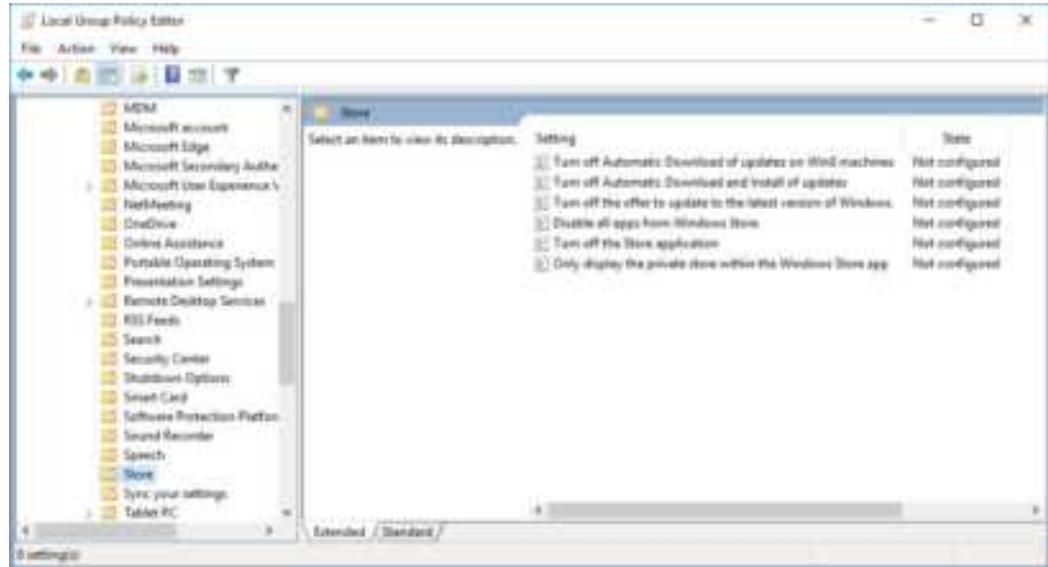
- 1 Type **Edit group policy** from the Windows search bar to locate the **Edit group policy editor** control panel.



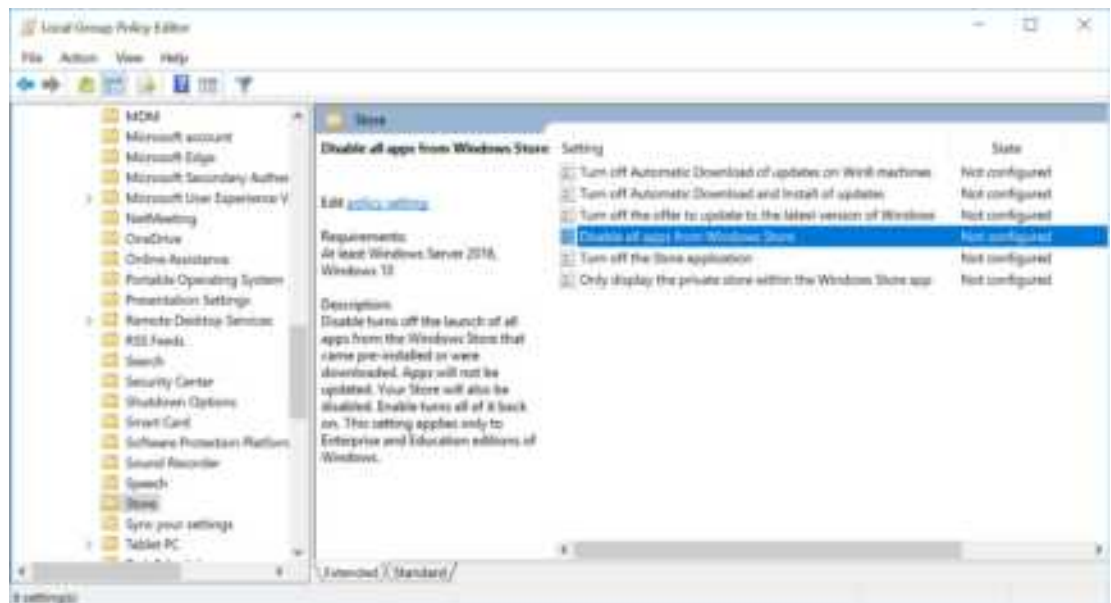
- 2 Select **Edit group policy editor**. The Local Group Policy Editor window displays.



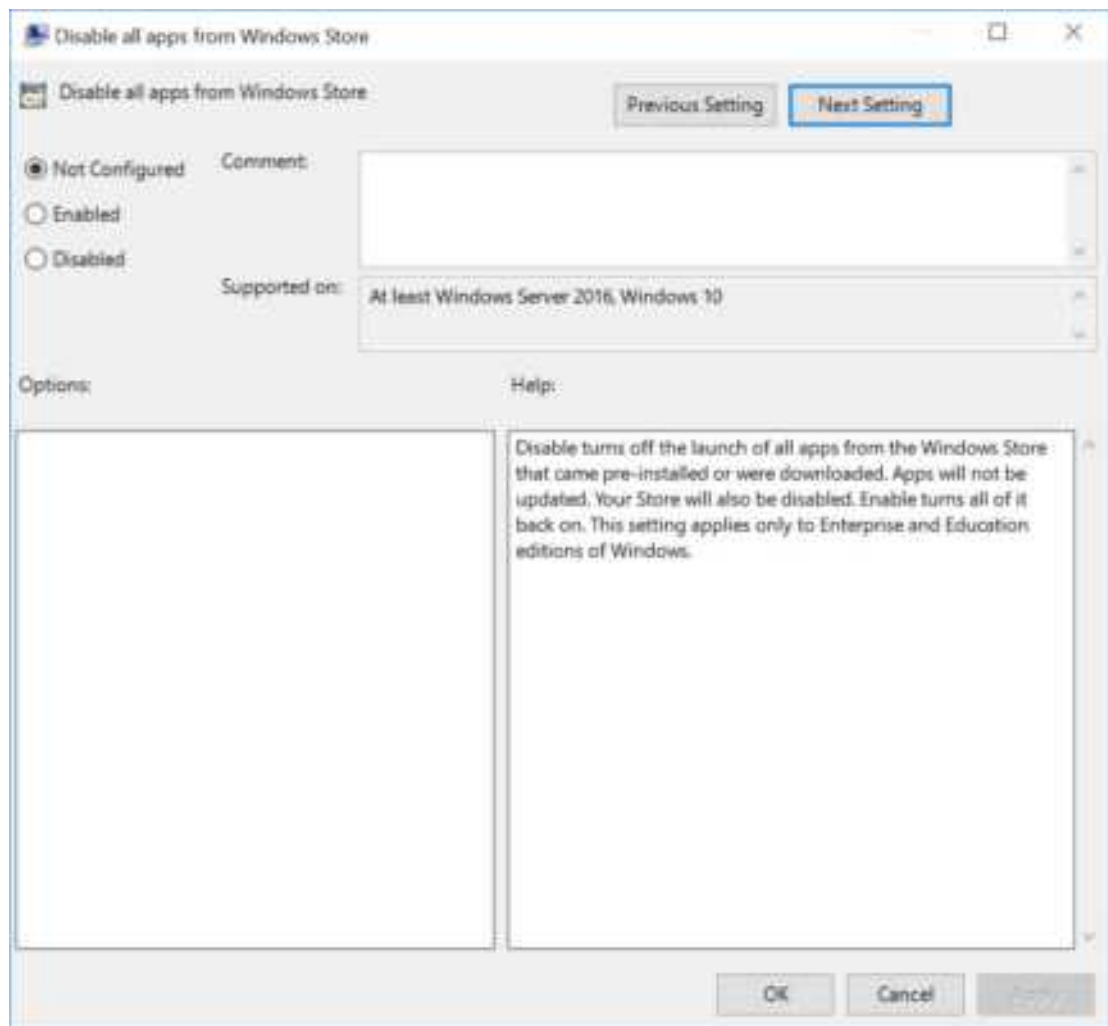
- 3 Navigate to **Computer Configuration > Administrative Templates > Windows Components > Store**.



- 4 Select **Disable all apps from Windows Store**.



The following window appears.



---

**5** Select **Enabled** and **Apply**.

---

**6** Select **OK** to close the window.

---

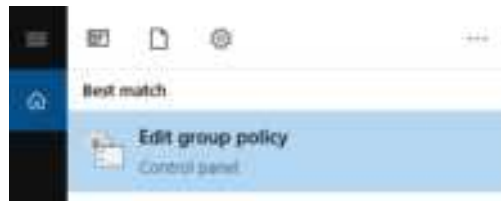
**7** Disable the following applications. Refer to Steps 4-6.

- Turn off **Automatic Download and Install of updates**.
  - Turn off the offer to update to the latest version of Windows.
  - Turn off the Store application.
-

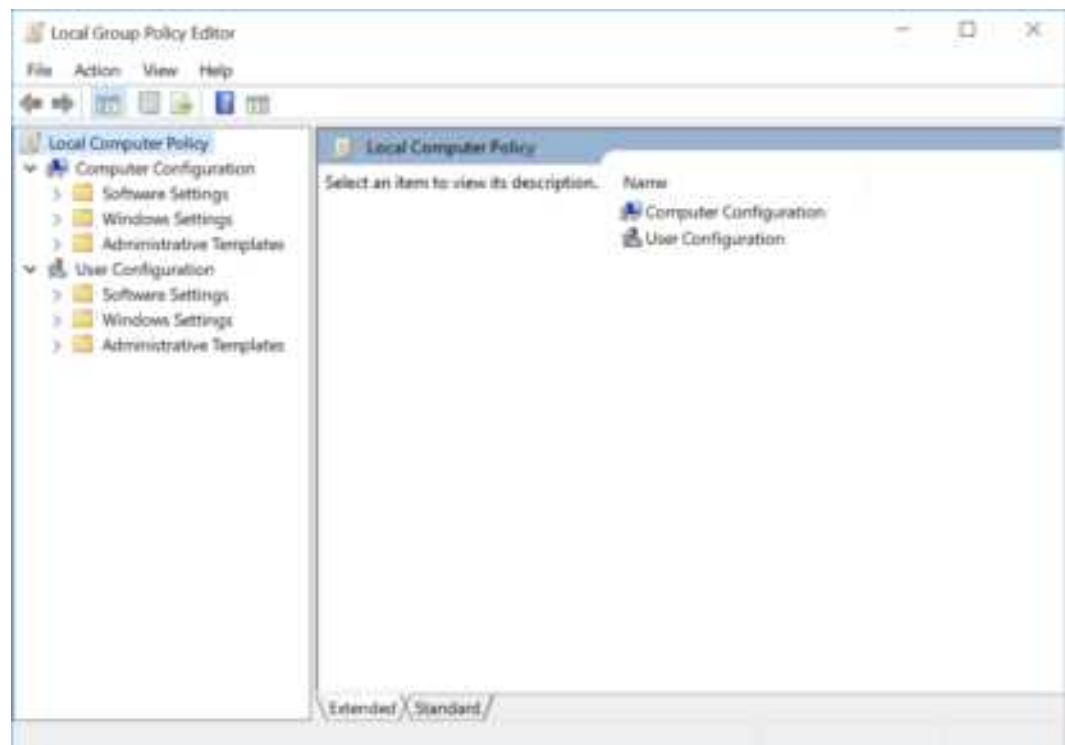
## Enabling SMB Digitally Sign Communications

The Server Message Block (SMB) protocol provides the basis for file and print sharing and many other networking operations, such as remote Windows administration. To prevent man-in-the-middle attacks that modify SMB packets in transit, follow the instructions below to enable the SMB Digitally Sign Communications.

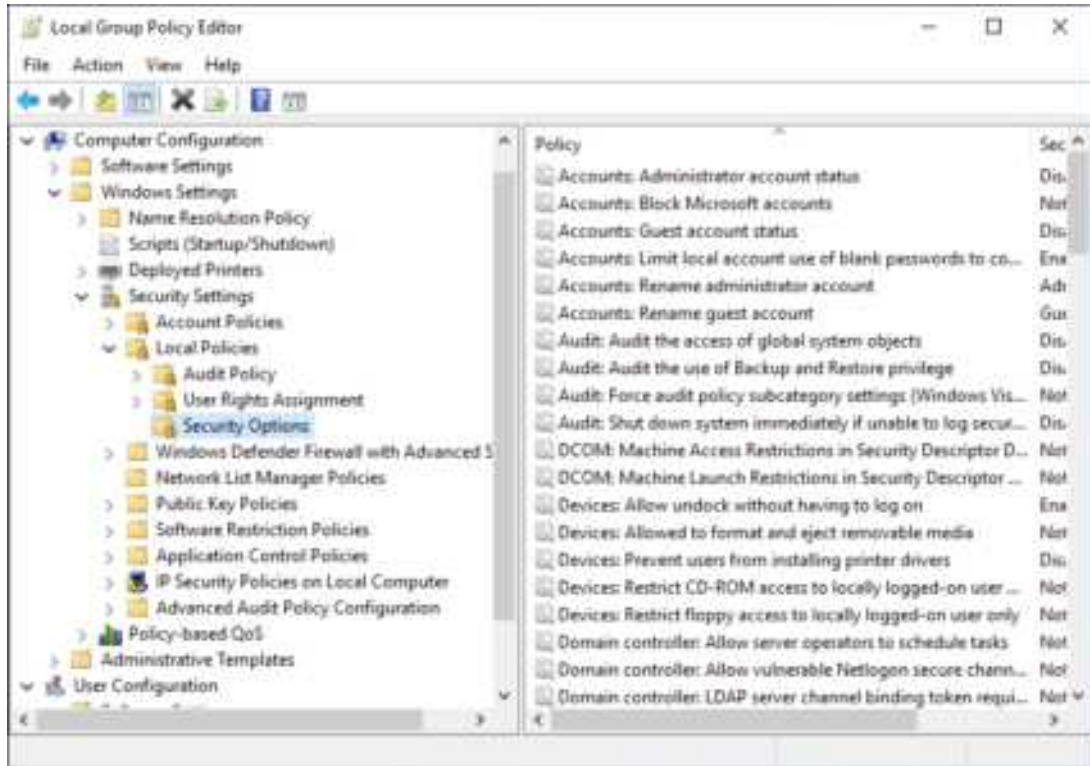
- 1 Type **Edit group policy** from the Windows search bar to locate the **Edit group policy editor** control panel.



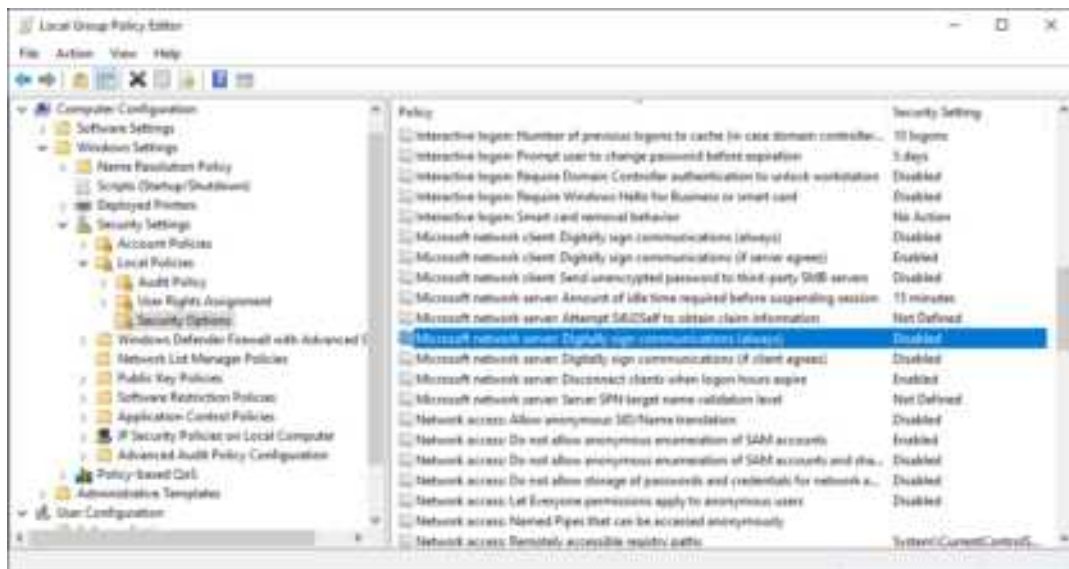
- 2 Select **Edit group policy editor**. The Local Group Policy Editor window displays.



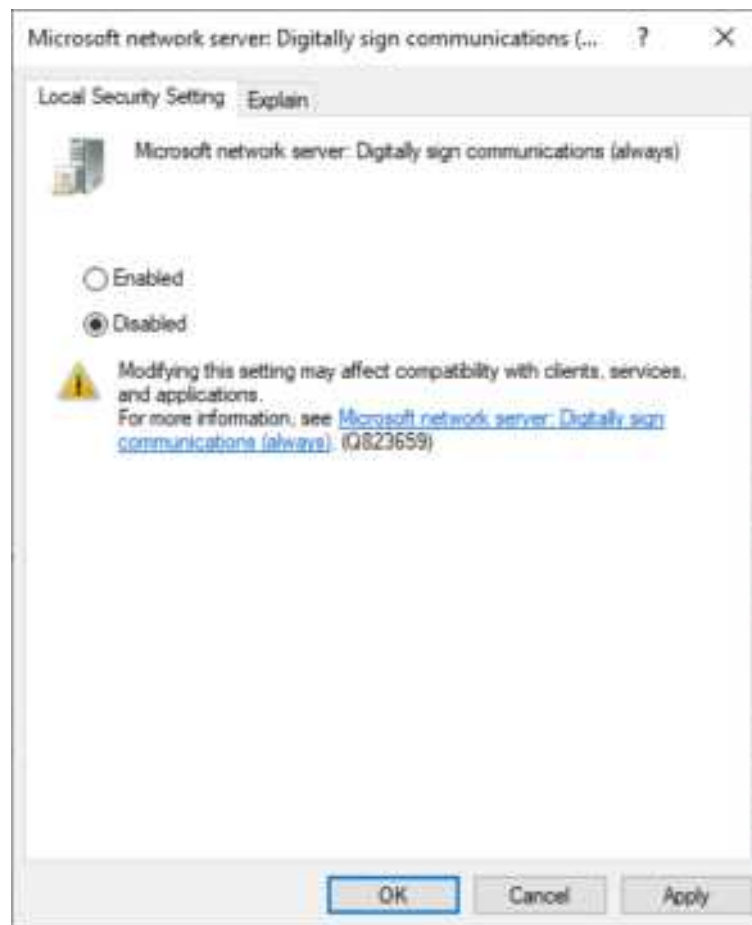
3 Navigate to **Computer Configuration > Windows Settings > Security Settings > Security Options**.



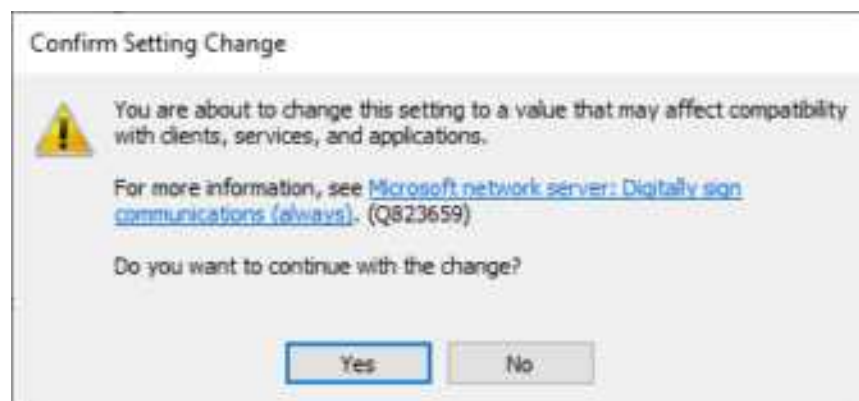
4 Select **Microsoft network server: Digitally sign communications (always)**.



The following window appears.



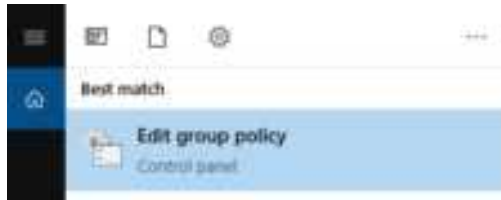
**5** Select **Enabled** and **Apply**. The Confirm window appears.



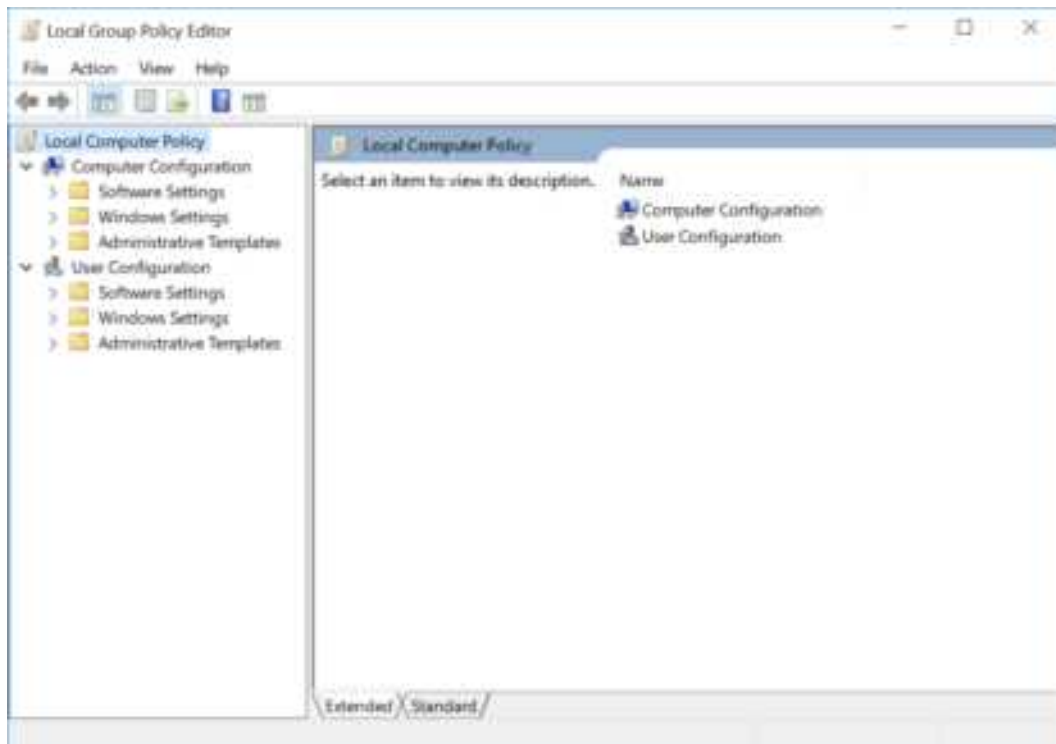
**6** Select **Yes**. Then select **OK** to close the window.

## Enabling Installation Restriction

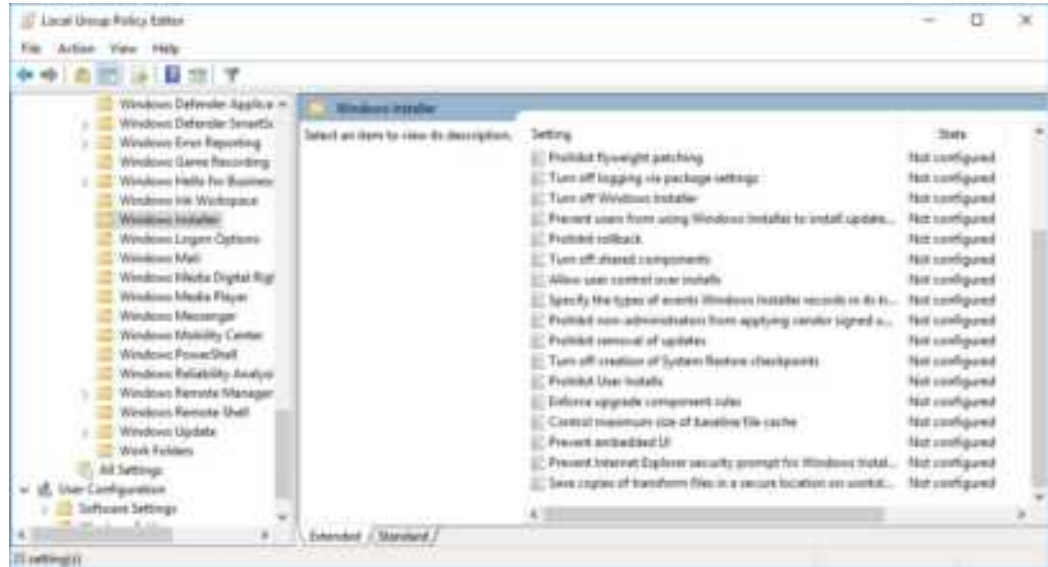
- 1 Type **Edit group policy** from the Windows search bar to locate the **Edit group policy editor** control panel.



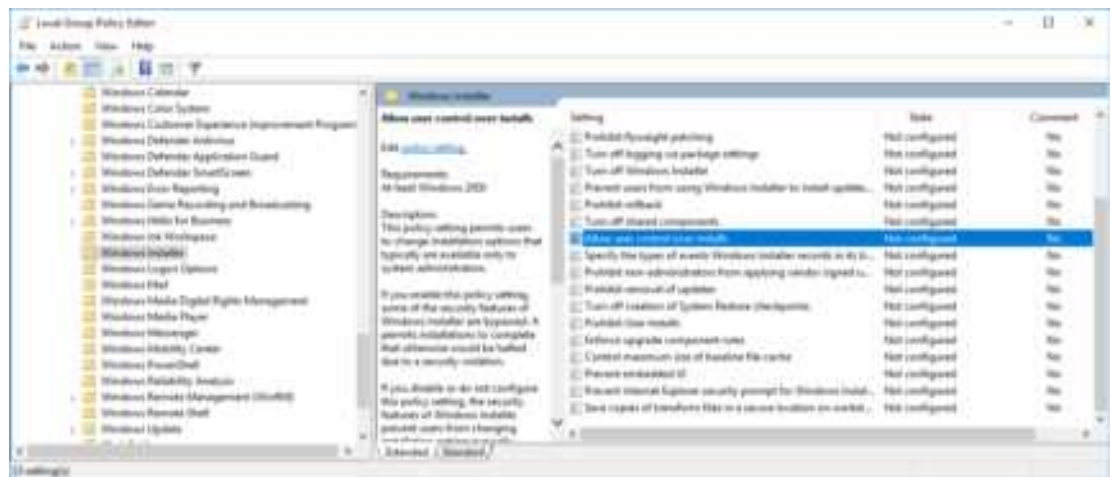
- 2 Select **Edit group policy editor**. The Local Group Policy Editor window displays.



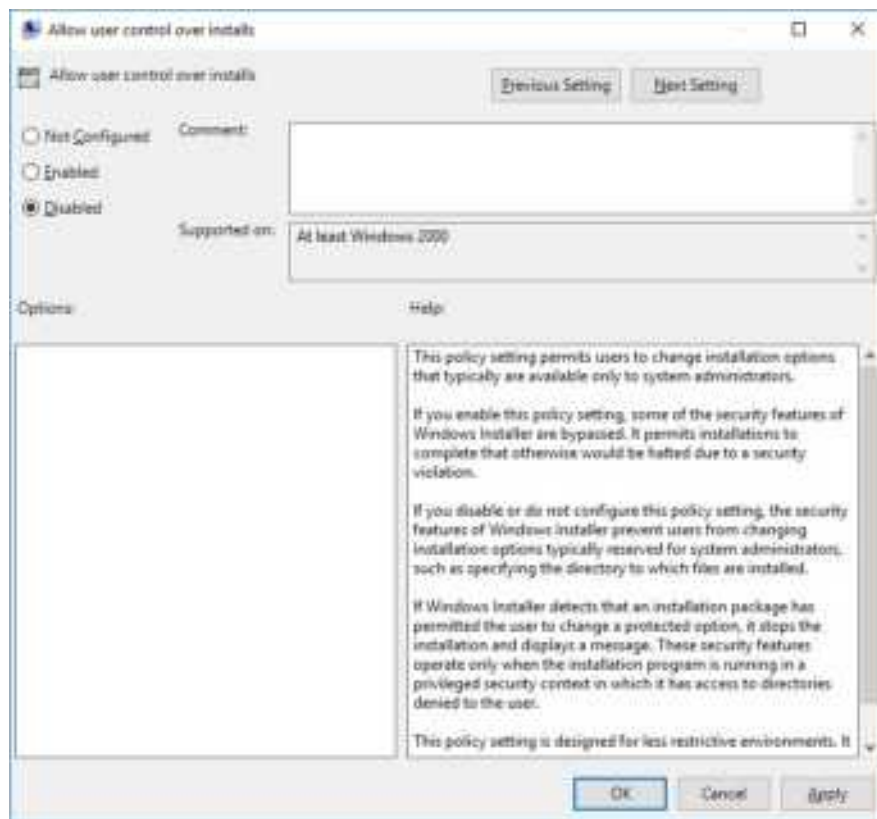
- 3 Navigate to **Computer Configuration > Administrative Templates > Windows Components > Windows Installer**.



- 4 Select **Allow user control over installs**.



The following window appears.



- 5 Select **Disabled** and **Apply**.
- 6 Select **OK** to close the window.
- 7 Disable **install with elevated privileges**. Refer to Steps 4-6.

## Enabling Firewall Defender

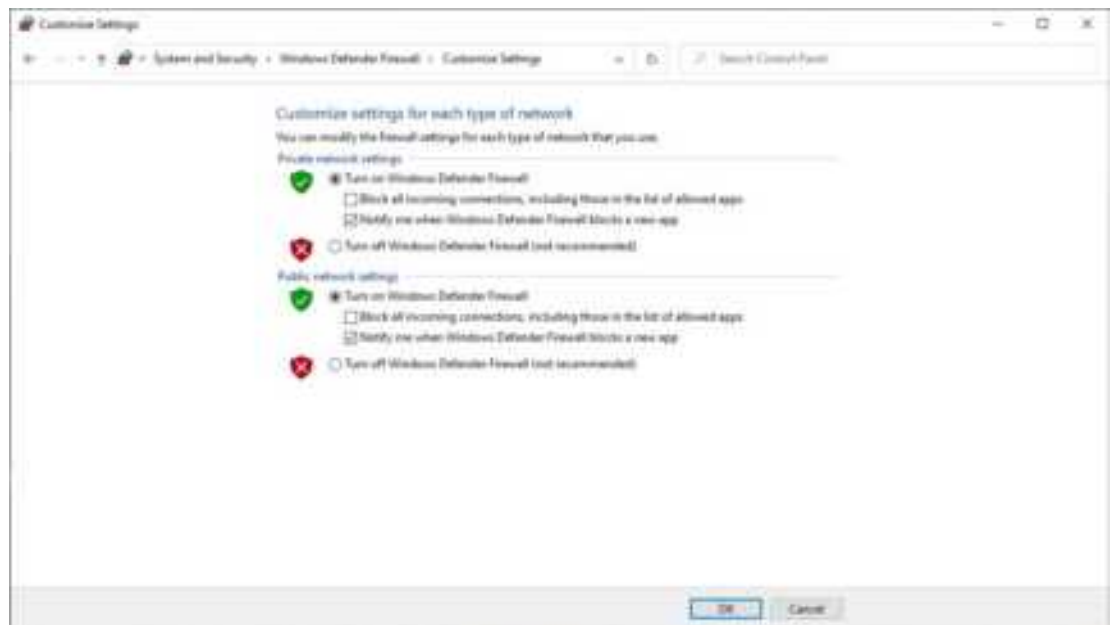
- 1 Type **Windows Defender Firewall** from the Windows search bar to locate the Windows Defender Firewall app.



**2** Select **Turn Windows Defender Firewall on or off**.



**3** Select **Turn on Windows Defender Firewall** for both Private network and Public network settings.

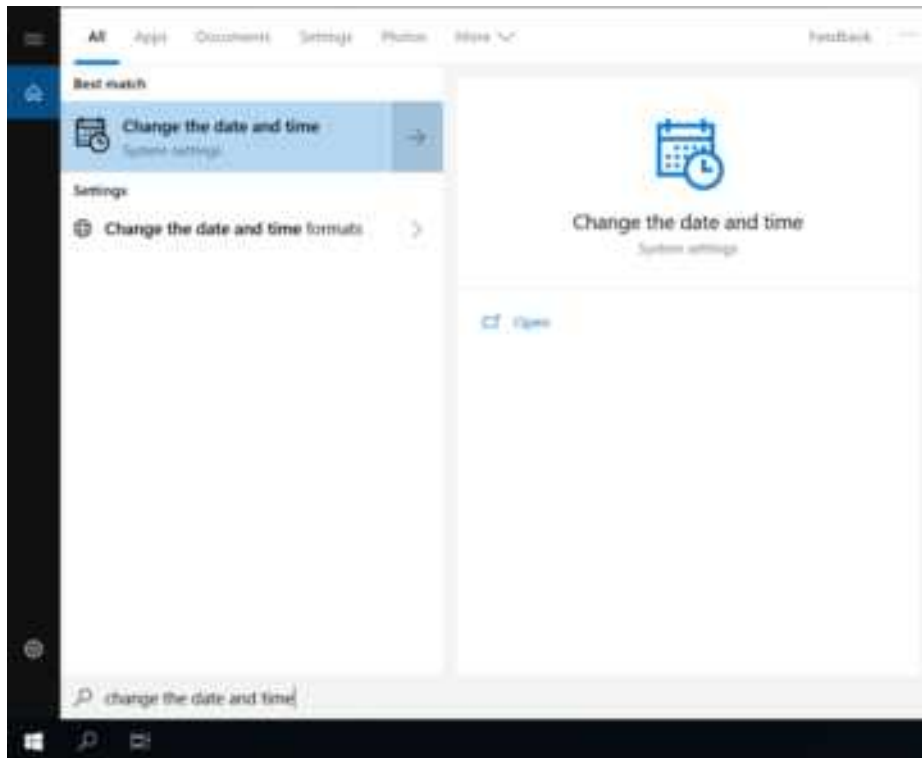


**4** Select **OK**.

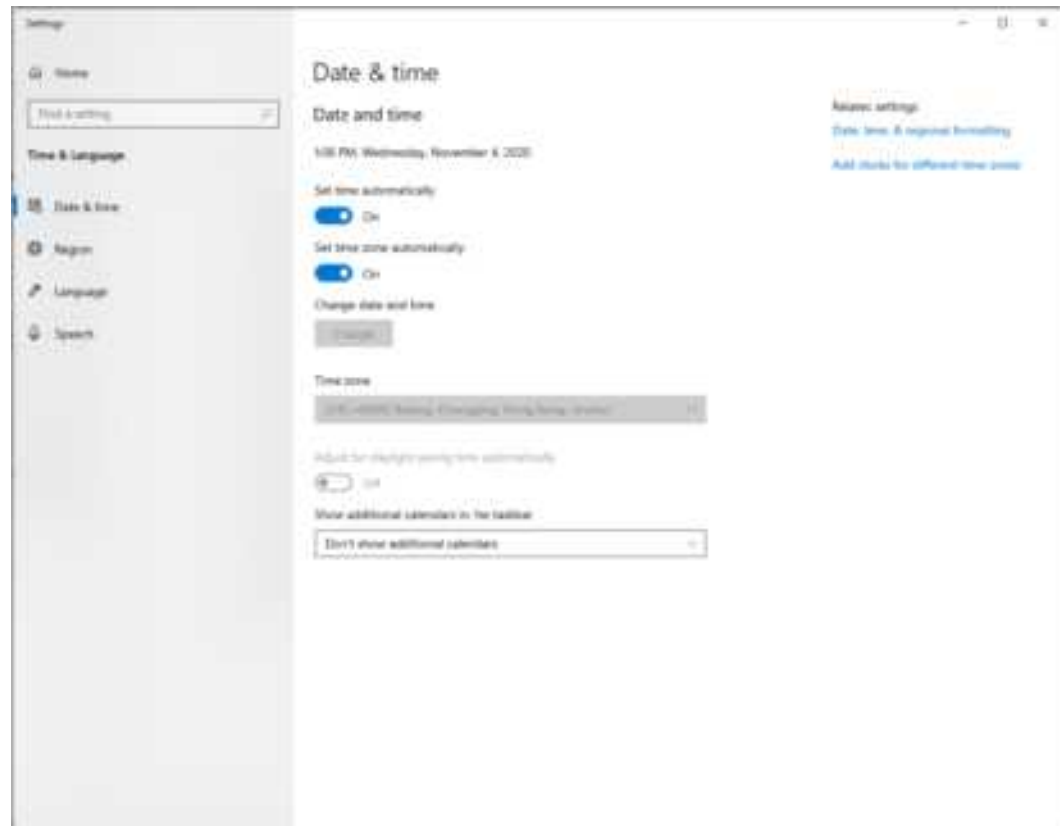
## Enabling Network Time Protocol

To ensure the accuracy of date and time information included in logs, follow the instructions below to enable the Network Time Protocol.

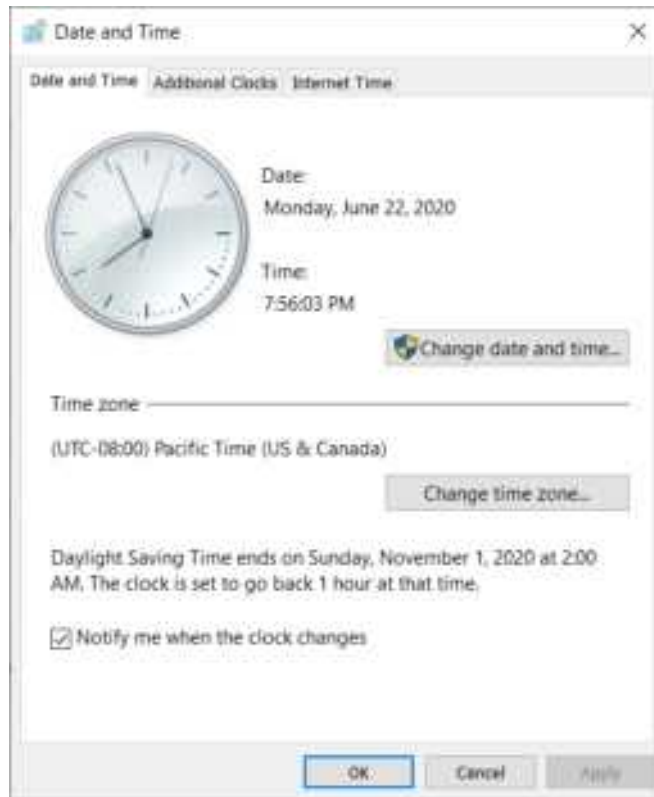
- 1 Type **Change the date and time** from the Windows search bar.



- 2 Double-click **Change the date and time**. The Date and Time Settings window appears.



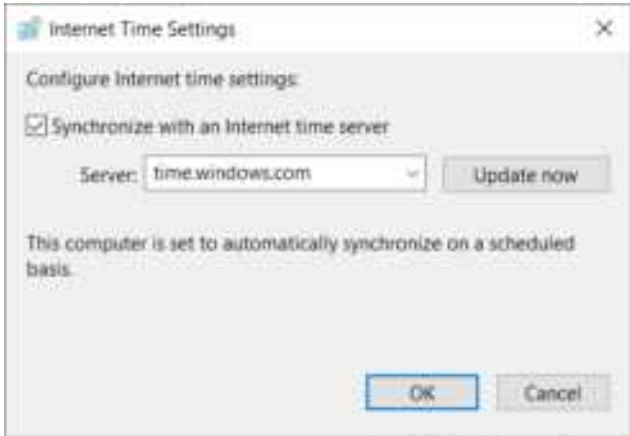
- 3 Select **Set time automatically** to access the Date and Time window.



4 Select **Change settings** from the Internet Time tab.



The Internet Time Settings window displays.



- 
- 5** Select **Synchronize with an internet time server**, and select **OK**. The PC is set to automatically synchronize with the internet time server.
-

# Table of Hazardous Substances

## Table of Hazardous Substances

---

The Hazardous Substances Names and Concentration are shown in [Table H.1](#), [Table H.2](#), and [Table H.3](#).

**Table H.1** 有毒有害物质名称及含量的标识格式 Table of Hazardous Substances Name and Concentration [CytoFLEX]

电子电气产品号码 EEP Part Number:	产品名称 Product Name: CytoFLEX 产品型号 Product Model Number:					
部件名称 Component Name	有毒有害物质或元素 Hazardous Substances Name					
	铅 (Pb)	汞 (Hg)	镉 (Cd)	六价铬 (Cr <sup>6+</sup> )	多溴联苯 (PBB)	多溴二苯醚 (PBDE)
印刷电路板组件 Circuit Boards	X	0	0	0	0	0
电源组件 Power Supplies	0	0	0	0	0	0
计算机 Computer	0	0	0	0	0	0
功率调节器 Power Conditioner	0	0	0	0	0	0
光量传感器 Optical Sensors	0	0	0	0	0	0
激光 Laser	0	0	0	0	0	0
发动机/泵/阀门/ Motors/Pumps/Valves	0	0	0	0	0	0
电线 Cables	X	0	0	0	0	0
管路及橡胶 Tubing & Rubber	0	0	0	0	0	0
塑料部件 Plastic	0	0	0	0	0	0
连接部件 Hardware	0	0	0	0	0	0
包装材料 Packing Material	0	0	0	0	0	0

This table is prepared in accordance with the provisions of SJ/T 11364

0: 表示该有毒有害物质在该部件所有均质材料中的含量均在GB/T 26572标准规定的限量要求以下

x: 表示该有毒有害物质至少在该部件的某一均质材料中的含量超出GB/T 26572标准规定的限量要求

(企业可在此处, 根据实际情况对上表中打“x”的技术原因进行进一步说明)

0: Indicates that the toxic or hazardous substances contained in all of the homogenous materials for this part is below the limit requirements in GB/T 26572.

X: Indicates that the toxic or hazardous substance contained in at least one of the homogenous materials used for this part in above the limit requirement in GB/T 26572.

**Table H.2** 有毒有害物质名称及含量的标识格式 Table of Hazardous Substances Name and Concentration [CytoFLEX S]

电子电气产品号码 EEP Part Number:	产品名称 Product Name: CytoFLEX S 产品型号 Product Model Number:					
部件名称 Component Name	有毒有害物质或元素 Hazardous Substances Name					
	铅 (Pb)	汞 (Hg)	镉 (Cd)	六价铬 (Cr <sup>6+</sup> )	多溴联苯 (PBB)	多溴二苯醚 (PBDE)
印刷电路板组件 Circuit Boards	X	0	0	0	0	0
电源组件 Power Supplies	0	0	0	0	0	0
计算机 Computer	0	0	0	0	0	0
功率调节器 Power Conditioner	0	0	0	0	0	0
光量传感器 Optical Sensors	0	0	0	0	0	0
激光 Laser	X	0	0	0	0	0
发动机/泵/阀门/ Motors/Pumps/Valves	0	0	0	0	0	0
电线 Cables	X	0	0	0	0	0
管路及橡胶 Tubing & Rubber	0	0	0	0	0	0
塑料部件 Plastic	0	0	0	0	0	0
连接部件 Hardware	X	0	0	0	0	0
包装材料 Packing Material	0	0	0	0	0	0

This table is prepared in accordance with the provisions of SJ/T 11364

○: 表示该有毒有害物质在该部件所有均质材料中的含量均在GB/T 26572标准规定的限量要求以下

x: 表示该有毒有害物质至少在该部件的某一均质材料中的含量超出GB/T 26572标准规定的限量要求

(企业可在此处, 根据实际情况对上表中打“x”的技术原因进行进一步说明)

O: Indicates that the toxic or hazardous substances contained in all of the homogenous materials for this part is below the limit requirements in GB/T 26572.

X: Indicates that the toxic or hazardous substance contained in at least one of the homogenous materials used for this part in above the limit requirement in GB/T 26572.

**Table H.3** 有毒有害物质名称及含量的标识格式 Table of Hazardous Substances Name and Concentration [CytoFLEX LX]

电子电气产品号码 EEP Part Number:	产品名称 Product Name: CytoFLEX LX 产品型号 Product Model Number:					
部件名称 Component Name	有毒有害物质或元素 Hazardous Substances Name					
	铅 (Pb)	汞 (Hg)	镉 (Cd)	六价铬 (Cr <sup>6+</sup> )	多溴联苯 (PBB)	多溴二苯醚 (PBDE)
印刷电路板组件 Circuit Boards	X	0	0	0	0	0
电源组件 Power Supplies	0	0	0	0	0	0
计算机 Computer	0	0	0	0	0	0
功率调节器 Power Conditioner	0	0	0	0	0	0
光量传感器 Optical Sensors	0	0	0	0	0	0
激光 Laser	X	0	0	0	0	0
发动机/泵/阀门/ Motors/Pumps/Valves	0	0	0	0	0	0
电线 Cables	X	0	0	0	0	0
管路及橡胶 Tubing & Rubber	0	0	0	0	0	0
塑料部件 Plastic	0	0	0	0	0	0
连接部件 Hardware	X	0	0	0	0	0
包装材料 Packing Material	0	0	0	0	0	0

This table is prepared in accordance with the provisions of SJ/T 11364

0: 表示该有毒有害物质在该部件所有均质材料中的含量均在GB/T 26572标准规定的限量要求以下

x: 表示该有毒有害物质至少在该部件的某一均质材料中的含量超出GB/T 26572标准规定的限量要求

(企业可在此处, 根据实际情况对上表中打“x”的技术原因进行进一步说明)

0: Indicates that the toxic or hazardous substances contained in all of the homogenous materials for this part is below the limit requirements in GB/T 26572.

X: Indicates that the toxic or hazardous substance contained in at least one of the homogenous materials used for this part in above the limit requirement in GB/T 26572.

# Abbreviations

The following list is a composite of the symbols, abbreviations, acronyms, and reference designators either used in this manual or related to the information in it. When the same abbreviation (or reference designator) is used for more than one word (or type of component), all meanings relevant to this manual are included, separated by semicolons.

' — foot	<b>BP</b> — band-pass filter
“ — inch	<b>CDRH</b> — Center for Devices and Radiological Health
% — percent	<b>CFSE</b> — carboxyfluorescein succinimidyl ester
°C — degrees Celsius	<b>cm</b> — centimeters
°F — degrees Fahrenheit	<b>CSV</b> — comma separated value
± — plus or minus	<b>CV</b> — coefficient of variation
< — less than	<b>DNA</b> — deoxyribonucleic acid
> — greater than	<b>DW</b> — deep well
≤ — less than or equal to	<b>ECD</b> — Energy Coupled Dye
μ — micron	<b>EFUP</b> — Environmentally friendly Use Period
μL — microliters	<b>EMC</b> — Electromagnetic Compatibility
μm — micrometer	<b>EMF</b> — enhanced metafile format
<b>A</b> — ampere	<b>EMR</b> — electromagnetic radiation
<b>AC</b> — alternating current	<b>FAPD</b> — Fiber Array Photo Detector
<b>APC</b> — Allophycocyanin	<b>FCS</b> — flow cytometry standard
<b>APC-A700</b> — Allophycocyanin-Alexa Fluor 700 tandem dye	<b>FITC</b> — Fluorescein isothiocyanate
<b>APC-A7500</b> — Allophycocyanin-Alexa Fluor 750	<b>FLn</b> — Fluorescence Number
<b>APC-Cy7</b> — Allophycocyanin-Cyanin 7	<b>FSC</b> — forward scatter
<b>API</b> — Application Programming Interface	<b>GB</b> — gigabyte
<b>Acq.</b> — Acquisition	<b>GHz</b> — gigahertz
<b>BCI</b> — Beckman Coulter Incorporated	<b>Gr Wt</b> — gross weight
<b>BMP</b> — bitmap	<b>H</b> — humidity
	<b>Hz</b> — hertz

<b>IEC</b> — International Electrotechnical Commission	<b>PI</b> — Propidium Iodide
<b>IR</b> — infrared	<b>PN</b> — part number
<b>kg</b> — kilograms	<b>QC</b> — quality control
<b>KO</b> — Krome Orange	<b>RAM</b> — random access memory
<b>LED</b> — light emitting diode	<b>rCV</b> — robust coefficient of variation
<b>L</b> — liter	<b>RH</b> — relative humidity
<b>LJ</b> — Levey-Jennings	<b>RoHS</b> — Restriction of Hazardous Substances Directive
<b>LWH</b> — length, width, height	<b>RPTM</b> — real-time messaging protocol
<b>m</b> — meter	<b>S/N</b> — serial number
<b>MB</b> — megabyte	<b>SNR</b> — signal to noise ratio
<b>MFI</b> — median fluorescence intensity	<b>SSC</b> — side scatter
<b>MHz</b> — megahertz	<b>USB</b> — universal serial bus
<b>min</b> — minute	<b>UV</b> — ultraviolet
<b>mL</b> — milliliter	<b>V</b> — volts
<b>mm</b> — millimeter	<b>VA</b> — volt-ampere
<b>mW</b> — milliwatt	<b>VAC</b> — voltage alternating current
<b>NA</b> — numerical aperture	<b>VSSC</b> — violet side scatter
<b>NaClO</b> — sodium hypochlorite solution	<b>WDM</b> — wavelength division multiplexer
<b>NaN<sub>3</sub></b> — sodium azide	<b>W</b> — watts
<b>nm</b> — nanometer	
<b>Nt Wt</b> — net weight	
<b>PB</b> — Pacific Blue dye	
<b>PC5</b> — Phycoerythrin-Cy5 tandem dye	
<b>PC5.5</b> — Phycoerythrin-Cy5.5 tandem dye	
<b>PC7</b> — Phycoerythrin-Cy7 tandem dye	
<b>PE</b> — Phycoerythrin	
<b>PEEK</b> — polyether ether ketone	
<b>PerCP</b> — Peridinin-Chlorophyll	

routine maintenance, [12-22](#), [12-31](#)

## Symbols

- '  
define, [Abbreviations-1](#)
- "  
define, [Abbreviations-1](#)
- °C  
define, [Abbreviations-1](#)
- °F  
define, [Abbreviations-1](#)
- μ  
define, [Abbreviations-1](#)
- μL  
define, [Abbreviations-1](#)
- μm  
define, [Abbreviations-1](#)
- ±  
define, [Abbreviations-1](#)
- <  
define, [Abbreviations-1](#)
- >  
define, [Abbreviations-1](#)

## Numerics

- 10 L sheath fluid cubitainer  
replacing, [12-7](#)
- 10 L waste cubitainer (CytoFLEX LX)  
emptying, [12-10](#)
- 4 L sheath fluid container  
to clean, [11-11](#)
- 4 L sheath fluid container (cleaning)  
routine maintenance, [11-11](#)
- 4 L sheath fluid container (CytoFLEX)  
filling, [12-6](#)
- 4 L waste container  
to clean, [11-12](#)
- 4 L waste container (cleaning)  
routine maintenance, [11-12](#)
- 4 L waste container (CytoFLEX)

emptying, [12-9](#)

## A

- A  
define, [Abbreviations-1](#)
- about this manual, [xli](#)
- AC  
define, [Abbreviations-1](#)
- account  
locking, [4-9](#)  
unlock, [2-27](#)
- account menu, [2-21](#)
- account policies, [2-31](#)
- acoustic noise level, [1-38](#)
- Acq.  
define, [Abbreviations-1](#)
- acquisition screen, [2-3](#)  
collection, [2-5](#)  
navigation, [2-4](#)  
plot area, [2-8](#)  
status bar, [2-9](#)  
test tubes, [2-7](#)
- acquisition settings  
to configure, [6-38](#)
- add  
vertex to auto polygon gate, [6-30](#)
- adding  
Deep Clean solution, [12-17](#)  
standardization item, [5-34](#)
- adding channels  
for compensation, [7-22](#)
- adjust compensation  
manually, [7-16](#)
- adjusting  
autogate movement, [6-31](#)  
compensation, [7-16](#)  
compensation settings, [8-8](#)  
gain, [6-41](#)  
threshold, [6-43](#)
- adjusting auto gates, [6-28](#)
- adjustment  
nonscheduled, [12-78](#)

- routine, 12-2
- advanced menu, 2-20
- alarm
  - Fluidics module, 1-19
  - mute, 1-19
- alarm does not sound when the waste container is full or the sheath fluid container is low and the software status display is red, 10-10
- alerts
  - caution define, xvii
  - important define, xvii
  - note define, xvii
  - warning define, xvii
- analysis
  - screen, 8-1
- analysis screen, 2-9
  - to open, 8-3
- analyzing
  - data, 6-73
- APC
  - define, Abbreviations-1
- APC-A7500
  - define, Abbreviations-1
- APC-Cy7
  - define, Abbreviations-1
- API
  - define, Abbreviations-1
- applying
  - standardization in QC, 5-38, 5-41
- auto gates
  - adjusting, 6-28
  - creating, 6-28
- auto polygon gate
  - add vertex, 6-30
- auto recalculate
  - turn off, 6-30
  - turn on, 6-30
- auto sampling system
  - Deep Clean solution peristaltic pump, 1-19
- auto shutdown, 6-8, 9-3, 11-7
- auto startup, 9-3
- autogate
  - adjusting movement, 6-31
  - extent, 6-32
  - movement, 6-31
- automated software feature, 3-6

**B**

- backflush settings
  - to change, 12-94
- backup, 10-20
  - manual injection mode, 4-10
- band-pass filter, 1-7, 1-9, 1-11, 1-12, 1-14, Abbreviations-1
- band-pass filters, 1-6
- bar-code labels
  - used on sample carousel, 3-1
- BCI
  - define, Abbreviations-1
- beam shaping
  - laser, 3-3
- Beckman Coulter Customer Support Center,
  - contacting, ii
- BMP
  - define, Abbreviations-1
- bold face font
  - conventions, xliii
- bottle
  - Deep Clean solution, 1-19
- BP
  - define, Abbreviations-1

**C**

- calculating
  - compensation values, 7-8, 7-13
  - concentration, 8-7
  - sample volume, 8-7
- calculation of the automatic compensation
  - experiment is incorrect, 10-14
- calculations
  - compensation, 7-1
- calibrating
  - plate position [with plate loader], 12-95
  - sample flow rate, 12-78
  - sample flow rate with plate loader, 12-82
- call center, contact information, ii
- carousel, sample
  - bar-code labels, 3-1
  - description, 3-1
  - See also MCL
- caution
  - define, xvii
- CDRH
  - define, Abbreviations-1
- cell illumination

- description, 3-4
- CFSE
  - define, [Abbreviations-1](#)
- change
  - password, 2-27
- changing
  - mixer and backflush settings, 12-94
  - tube name, 6-38
- changing sample probe
  - from plate loader to single tube sample station, 12-59
  - from single tube sample station to plate loader, 12-54
- channel
  - to set, 6-16
- channels
  - adding for compensation, 7-22
  - fluorescence, 6-49, 6-50
  - to set, 6-16
- characteristics
  - performance, 1-41
- check
  - waste and reagent levels (10 L fluid cubitainers), 4-4
  - waste and reagent levels (4 L fluid containers), 4-2
- cleaning
  - 4 L sheath fluid container, 11-11
  - 4 L waste container, 11-12
  - nonscheduled, 11-14
  - routine, 11-1
  - sample probe, 11-8
  - sample station, 11-7
  - surfaces, 11-14
- cleaning and ventilation
  - installation environment validation, [A-2](#)
- cleaning solution
  - to prepare, 9-1
- cleaning the 4 L sheath fluid container
  - routine maintenance, 11-11
- cleaning the 4 L waste container
  - routine maintenance, 11-12
- cleaning the sample station
  - routine maintenance, 11-7
- closed file system
  - electronic record management, [B-2](#)
- cm
  - define, [Abbreviations-1](#)
- collecting
  - data, 6-58
  - QC data, 5-12
  - QC data with plate loader, 5-15
- collection
  - acquisition screen, 2-5
- collection conditions
  - to set, 6-44
- compensation
  - adding channels, 7-22
  - calculations, 7-1
  - to adjust, 7-16
  - to manually adjust, 7-16
- compensation controls
  - compensation experiment screen, 2-11
- compensation experiment
  - to create, 7-2
- compensation experiment screen, 2-11
  - compensation controls, 2-11
- compensation experiment with plate loader
  - creating, 7-10
- compensation library
  - to manage, 7-21
- compensation matrix
  - to create from previously acquired data, 7-14
  - to generate, 7-4, 7-13
- compensation sample
  - prepare, 7-4, 7-13
- compensation settings
  - adjust, 8-8
  - exporting, 7-19
  - importing and exporting, 6-83
- compensation settings from compensation library
  - to import, 7-18
- compensation settings from compensation matrix files
  - to import, 7-16
- compensation values
  - to calculate, 7-8, 7-13
- components
  - Cytometer, 1-2
  - Fluid Containers/Cubitainers, 1-2
  - fluidics system, 1-17
  - instrument, 1-1
  - main, 1-2
  - optical, 1-4
  - plate holder, 1-27
  - plate loader, 1-23
  - sample injection mode control kit, [C-2](#)
  - Workstation, 1-2

- concentration
  - calculation, [8-7](#)
  - sample volume, [8-7](#)
- concentration calculation is incorrect, [10-15](#)
- concluding
  - experiment, [6-86](#)
- configuration
  - system, [1-31](#)
- configuring
  - acquisition settings, [6-38](#)
- confirming results, [5-20](#)
- connection indicator light in the lower left corner of the software screen is red and displays Disconnected and Error, [10-10](#)
- contact information, Beckman Coulter Customer Support Center, [ii](#)
- conventions
  - bold face font, [xliv](#)
  - the term press, [xliv](#)
  - the term select, [xliv](#)
- conventions used, [1-xliv](#)
- copying
  - experiments, [8-1](#)
  - previously acquired experiment, [8-1](#)
- create a compensation experiment
  - start page operations, [2-2](#)
- create a new experiment from a template
  - start page operations, [2-2](#)
- create a new screen
  - start page operations, [2-2](#)
- creating
  - compensation experiment, [7-2](#)
  - compensation experiment with plate loader, [7-10](#)
  - compensation matrix from previously acquired data, [7-14](#)
  - detector configuration, [6-48](#)
  - dot plot overlays, [8-5](#)
  - heat map (plate loader), [6-63](#)
  - histogram overlays, [8-5](#)
  - Levey-Jennings charts, [5-23](#)
  - new experiment, [6-1](#)
  - new experiment with plate loader, [6-1](#), [6-3](#)
  - plots and gates, [6-19](#)
  - user roles, [2-29](#)
  - users, [2-25](#)
- creating auto gates, [6-28](#)
- CSV
  - define, [Abbreviations-1](#)
- custom filter, [E-1](#)
- custom statistics
  - setting, [6-35](#)
- customer-replaceable parts
  - ordering, [H-1](#)
- customized parameters
  - setting, [6-33](#)
- CV
  - define, [Abbreviations-1](#)
- cyber security, [G-53](#)
  - backing up your recovery key, [G-13](#)
  - BitLocker decryption, [G-17](#)
  - BitLocker encryption, [G-6](#)
  - BitLocker keys, [G-2](#)
  - changing encryption strength, [G-2](#)
  - disabling McAfee application control, [G-49](#)
  - drive encryption, [G-2](#)
  - enabling McAfee application control, [G-32](#)
  - exporting certificate, [G-35](#)
  - good practices in cyber security, [G-1](#)
  - Importing certificate, [G-45](#)
  - installing McAfee Application Control, [G-26](#)
  - malware detection software, [G-25](#)
  - operating system patching, [G-57](#), [G-61](#)
  - recovering your BitLocker key, [G-23](#)
  - suspending BitLocker drive encryption, [G-21](#)
  - switching McAfee Application control to update mode, [G-47](#)
- CytExpert
  - installation options, [A-12](#)
- CytExpert API test client
  - setup, [2-48](#)
- CytExpert certificate, [G-35](#)
- CytExpert software
  - reinstall, [A-29](#)
  - upgrade, [A-24](#)
- Cytobank, [2-14](#)
  - instrument, [1-36](#)
- dimensions, [1-36](#)
  - instrument, [1-37](#)
- dimensions, [1-37](#)
- Cytometer, [1-2](#), [1-3](#), [A-6](#)
- Cytometer cannot be turned on, [10-9](#)
- cytometer menu, [2-17](#)

**D**

- daily shutdown
  - routine maintenance, [11-1](#)
- daily shutdown with plate loader
  - routine maintenance, [11-5](#)
- daily start up
  - routine maintenance, [11-1](#)
- daily start up with plate loader
  - routine maintenance, [11-5](#)
- data
  - analyzing, [6-73](#)
  - collecting, [6-58](#)
  - exporting, [6-73](#)
  - sampling, [6-58](#)
  - to import, [8-1](#)
- data populations are normal on one laser, but too low on another laser, [10-13](#)
- data populations are not where they are expected, [10-14](#)
- data sheets, material safety
  - how to order, [1-44](#)
- data storage
  - description, [3-6](#)
- Deep Clean
  - procedure, [11-9](#)
  - routine maintenance, [11-9](#)
- Deep Clean solution
  - to add, [12-17](#)
  - to prepare, [12-17](#)
- Deep Clean solution bottle
  - fluidics module, [1-19](#)
- Deep Clean solution peristaltic pump
  - auto sampling system, [1-19](#)
- default
  - detector configuration, [6-49](#)
- default password, [2-24](#), [A-24](#)
- default username
  - username
    - default, [A-24](#)
- define
  - %, [Abbreviations-1](#)
  - caution, [xvii](#)
  - important, [xvii](#)
  - note, [xvii](#)
  - quality control (QC), [5-1](#)
  - symbols, [-xix](#)
  - warning, [xvii](#)
- defining the negative population, [7-5](#)
- delete
  - experiment directory (electronic record management), [B-4](#)
  - heat map parameter, [6-65](#)
- deleting
  - heat map (plate loader), [6-72](#)
  - standardization items, [5-46](#)
  - user roles, [2-30](#)
  - users, [2-26](#)
- detector (WDM)
  - optical components, [1-4](#)
- detector configuration
  - to create, [6-48](#)
  - to edit, [6-48](#)
  - to select, [6-48](#)
  - to verify, [6-48](#)
- detector configuration default, [6-49](#)
- detector unit
  - wavelength division multiplexor (WDM), [1-5](#)
- disabling lasers, [6-40](#)
- disinfection
  - surfaces, [11-14](#)
- disposal
  - precaution, [10-9](#)
  - waste, [A-4](#)
- DNA
  - define, [Abbreviations-1](#)
- document overview, [xli](#)
- dot plot overlays
  - to create, [8-5](#)
- downloading security updates, [G-57](#)
- drive decryption
  - enabling BitLocker, [G-17](#)
- drive encryption, [G-2](#)
  - BitLocker keys, [G-2](#)
  - BitLocker recovery, [G-23](#)
  - changing encryption strength level for BitLocker, [G-2](#)
  - enabling BitLocker, [G-6](#)
- dual-parameter plots, [2-34](#)
- duplicating
  - standardization item parameters, [5-45](#)
- DW
  - define, [Abbreviations-1](#)

**E**

- ECD
  - define, [Abbreviations-1](#)
- editing
  - detector configuration, [6-48](#)

- standardization item parameters, 5-45
  - EFUP
    - define, [Abbreviations-1](#)
  - electronic devices
    - fuse, 1-32, 1-34
    - load button, 1-32, 1-34
    - power switch, 1-32, 1-34
  - electronic record management
    - closed file system, B-2
    - electronic signature, B-17
    - experiment directory management, B-3
    - experiment management, B-2
    - experiment operation log, B-12
    - experiment related operations, B-5
    - exporting an experiment/template, B-9
    - folder hierarchy management, B-4
    - importing an experiment/template, B-6
    - log, B-12
    - software menu, B-1
    - system operation log, B-15
    - user management, B-26
    - user management operation log, B-16
  - electronic signature
    - electronic record management, B-17
    - retract, B-20
  - EMC
    - define, [Abbreviations-1](#)
  - EMF
    - define, [Abbreviations-1](#)
  - emptying
    - 10 L waste cubitainer (CytoFLEX LX), 12-10
    - 4 L waste container (CytoFLEX), 12-9
  - EMR
    - define, [Abbreviations-1](#)
  - enabling lasers, 6-40
  - environment validation
    - installation, A-2
  - environment validation (installation)
    - power source, A-3
    - temperature and humidity, A-4
    - ventilation and cleaning, A-2
    - worktable, A-2
  - exchange detector configuration
    - WDM beam splitter, F-4
  - exit the software
    - start page operations, 2-2
  - experiment
    - concluding, 6-86
    - sign, B-17
  - experiment (new)
    - creating, 6-1
  - experiment directory (electronic record management)
    - delete, B-4
    - rename, B-4
    - setup, B-3
  - experiment directory management
    - electronic record management, B-3
  - experiment management
    - electronic record management, B-2
  - experiment operation log
    - electronic record management, B-12
  - experiment related operations
    - electronic record management, B-5
  - experiment saving, 6-86
  - experiment selection
    - start page, 4-27
  - experiment settings, 2-45
  - experiment signature
    - print, B-25
  - experiments
    - to copy, 8-1
  - exporting
    - compensation settings, 6-83, 7-19
    - data, 6-73
    - FCS files, 6-78
    - heat map (plate loader), 6-72
    - instrument settings, 6-81, 6-82
    - plots of multiple tubes as picture files, 6-80
    - results, 8-9
    - standardization item, 5-45
    - statistics table of multiple tubes as a picture file, 6-80
    - user logs, 2-33
  - exporting and experiment/template
    - electronic record management, B-9
  - extent
    - autogate, 6-32
- ## F
- FAPD
    - define, [Abbreviations-1](#)
  - FCS
    - define, [Abbreviations-1](#)
  - FCS files
    - exporting, 6-78
  - files menu, 2-15
  - filling

- 4 L sheath fluid container (CytoFLEX), 12-6
  - filling sheath fluid container, 4-2
  - filter, E-1
    - optical, 1-5
    - sheath fluid, 1-19
  - FITC
    - define, [Abbreviations-1](#)
  - FL
    - See fluorescent light (FL)
  - FLn
    - define, [Abbreviations-1](#)
  - flow cell
    - hydrodynamic focusing, 3-2
    - illustration, 3-3
    - to prime, 12-64
  - flow cell waste out
    - fluidic connection, 1-20, 4-3, 4-5
  - Fluid Container holder, 1-17
  - Fluid Containers, 1-2, 1-3, A-6
  - Fluid Containers/Cubitainers
    - component, 1-2
    - fluidics system, 1-18
    - fluidics system component, 1-17
  - fluid sensor holder cutout, 1-17
  - fluid status information displays red for Sheath and/or Waste even though the sheath fluid container is full and the waste container is empty, 10-11
  - fluidic connections
    - flow cell waste out, 1-20, 4-3, 4-5
    - sheath fluid in, 1-20, 4-3, 4-5
    - sheath fluid level sensor connector, 1-20, 4-3, 4-5
    - sheath return, 1-20, 4-3, 4-5
    - waste level sensor connector, 1-20, 4-3, 4-5
    - waste out, 1-20, 4-3, 4-5
  - Fluidics module
    - alarm, 1-19
  - fluidics module
    - Deep Clean solution bottle, 1-19
    - fluidics system, 1-19
    - fluidics system component, 1-17
    - sheath fluid filters, 1-19
  - fluidics system
    - components, 1-17
    - Fluid Containers/Cubitainers, 1-18
    - fluidics module, 1-19
  - fluidics system components
    - Fluid Containers/Cubitainers, 1-17
    - fluidics module, 1-17
  - fluorescence channels, 6-49, 6-50
  - fluorescent light (FL)
    - cell illumination, 3-4
    - collection, 3-5
    - when to use, example, 3-4
  - focusing, hydrodynamic
    - description, 3-2
  - folder hierarchy management
    - electronic record management, B-4
  - forward scatter (FS)
    - cell illumination, 3-4
  - four-quadrant gates
    - for dual-parameter plots, 2-35
  - front cover
    - removal, 12-2
  - FS
    - See forward scatter
  - FSC
    - define, [Abbreviations-1](#)
  - functions
    - software, 2-1
  - fuse
    - electronic devices, 1-32, 1-34
    - to replace, 12-90
- ## G
- gain
    - to adjust, 6-41
  - gate settings, 2-47
  - gates
    - to create, 6-19
  - gates for dual-parameter plots
    - four-quadrant gates, 2-35
    - lasso gates, 2-35
    - polygon gates, 2-35
    - rectangle gates, 2-35
  - gates for single-parameter plots
    - line-segment gates, 2-35
    - vertical gates, 2-35
  - GB
    - define, [Abbreviations-1](#)
  - generating
    - compensation matrix, 7-4, 7-13
  - Ghz
    - define, [Abbreviations-1](#)
  - Gr. Wt.
    - define, [Abbreviations-1](#)
  - graphic and gating styles, 2-34
  - graphics

printing, 6-83

## H

H

define, [Abbreviations-1](#)

hazard

laser, 10-1

hazards

laser beam, 10-2

radiation, 10-3

hazards/precautions, 10-1

heat map (plate loader)

creating, 6-63

deleting, 6-72

exporting, 6-72

modifying, 6-71

refreshing, 6-70

heat map parameter

deleting, 6-65

help menu, 2-22

help, Beckman Coulter Customer Support

Center, [ii](#)

histogram

types of display, 3-7

histogram overlays

to create, 8-5

how to

use your manual, [xli](#)

humidity and temperature

installation environment validation, [A-4](#)

hydrodynamic focusing

description, 3-2

Hz

define, [Abbreviations-1](#)

## I

IEC

define, [Abbreviations-2](#)

important

define, [xvii](#)

importing

compensation settings, 6-83

compensation settings from compensation library, 7-18

compensation settings from compensation matrix files, 7-16

data, 8-1

instrument settings, 6-81

lot-specific target values, 5-7

previously acquired data, 8-1

standardization item, 5-44

importing an experiment/template

electronic record management, [B-6](#)

information

ordering, 1-35

initializing the instrument, 4-28

inspecting materials

unpacking, [A-4](#)

inspection

liquid flow tubing, 12-63

pre-boot, 4-1

inspection when unpacking, [A-4](#)

installation

environment validation, [A-2](#)

instrument, [A-1](#)

software, [A-12](#)

installation category, 1-37

installation options

CytExpert, [A-12](#)

installing

custom filter, [E-1](#)

instrument configuration file, [A-22](#)

Plate Loader module, 12-67

software, [A-13](#)

installing security updates, [G-61](#)

installing the instrument and connecting the

equipment

unpacking inspection, [A-5](#), [A-11](#)

instrument

components, 1-1

initializing, 4-28

inspecting materials, [A-4](#)

installation, [A-1](#)

maintenance, 12-1

parameters, 1-38

shut off, 9-2

transportation and storage, [A-1](#)

unpacking, [A-4](#)

instrument characteristics, 1-36

instrument components

Cytometer, 1-2

Fluid Containers/Cubitainers, 1-2

Workstation, 1-2

instrument configuration

unpacking inspection, [A-4](#)

instrument configuration file

to install, [A-22](#)

- instrument dimensions, [1-36, 1-37](#)
  - instrument operations cannot be performed in the Acquisition screen, [10-16](#)
  - instrument settings
    - exporting, [6-82](#)
    - importing, [6-81](#)
    - importing and exporting, [6-81](#)
  - instrument specifications, [1-36](#)
  - instrument transport or storage
    - to prepare, [11-15](#)
  - IR
    - define, [Abbreviations-2](#)
  - items
    - adding for standardization, [5-34](#)
    - deleting for standardization, [5-46](#)
    - duplicating for standardization, [5-45](#)
    - editing for standardization, [5-45](#)
    - exporting for standardization, [5-45](#)
    - importing for standardization, [5-44](#)
- K**
- kg
    - define, [Abbreviations-2](#)
  - KO
    - define, [Abbreviations-2](#)
- L**
- L
    - define, [Abbreviations-2](#)
  - labels
    - to set, [6-16](#)
  - language settings, [2-48](#)
  - laser
    - beam shaping, [3-3](#)
    - hazards, [10-1](#)
    - settings, [6-38](#)
    - target power settings (CytoFLEX LX only), [6-40](#)
  - laser beam
    - hazards, [10-2](#)
  - laser delay
    - to set, [12-86](#)
  - laser delay values are out of range, [10-13](#)
  - laser lines, [1-38](#)
  - laser power is low, [10-12](#)
  - laser target power settings (CytoFLEX LX only), [6-40](#)
  - laser wavelength, [1-38](#)
  - lasers
    - disable, [6-40](#)
    - enable, [6-40](#)
  - lasso gates
    - for dual-parameter plots, [2-35](#)
  - launching the software, [2-1](#)
  - LED
    - define, [Abbreviations-2](#)
  - lenses
    - beam shaping, [3-3](#)
    - cross-cylindrical, [3-3](#)
  - Levey-Jennings charts
    - to create, [5-23](#)
  - light collection, separation and measurement
    - description, [3-4](#)
  - line segment gates
    - for single-parameter plots, [2-35](#)
  - liquid flow tubing
    - inspection, [12-63](#)
  - liquid flow tubing inspection
    - routine maintenance, [12-63](#)
  - LJ
    - define, [Abbreviations-2](#)
  - load button
    - electronic devices, [1-32, 1-34](#)
  - locking
    - account, [4-9](#)
  - log
    - electronic record management, [B-12](#)
    - user management operation, [2-33](#)
  - log in
    - software, [4-6](#)
  - log menu, [2-22](#)
  - logs
    - exporting, [2-33](#)
    - viewing, [2-33](#)
  - lot-specific target values
    - to import, [5-7](#)
  - LWH
    - define, [Abbreviations-2](#)
- M**
- m
    - define, [Abbreviations-2](#)
  - main components, [1-2](#)
  - maintenance
    - instrument, [12-1](#)
    - See also* routine maintenance; nonscheduled maintenance

- maintenance reminder
    - to manage, [12-14](#)
  - malware detection software, [G-25](#)
  - managing
    - compensation library, [7-21](#)
    - maintenance reminder, [12-14](#)
  - manual
    - about, [xli](#)
    - adjust compensation, [7-16](#)
  - manual injection mode
    - running small sample volumes, [4-10](#)
  - manuals
    - updating, [iii](#)
  - material safety data sheets (MSDS/SDS)
    - how to order, [1-44](#)
  - maximum altitude, [1-38](#)
  - MB
    - define, [Abbreviations-2](#)
  - McAfee application certificate, [G-45](#)
  - McAfee application control
    - disabling, [G-49](#)
    - enabling, [G-32](#)
    - update mode, [G-47](#)
  - MCL (Multi-Tube Carousel Loader)
    - loading the sample, [3-1](#)
  - menu
    - account, [2-21](#)
    - acquisition and analysis screen, [2-15](#)
    - advanced, [2-20](#)
    - cytometer, [2-17](#)
    - files, [2-15](#)
    - help, [2-22](#)
    - log, [2-22](#)
    - QC/Standardization, [2-20](#)
    - settings, [2-19](#)
    - signature, [2-22](#)
    - software, [2-14](#)
  - menu tree
    - software, [2-14](#)
  - MFI
    - define, [Abbreviations-2](#)
  - MHz
    - define, [Abbreviations-2](#)
  - min
    - define, [Abbreviations-2](#)
  - mixer is not functioning, [10-16](#)
  - mixer settings
    - to change, [12-94](#)
  - mL
    - define, [Abbreviations-2](#)
  - mm
    - define, [Abbreviations-2](#)
  - modifying
    - heat map (plate loader), [6-71](#)
    - user roles, [2-30](#)
    - users, [2-26](#)
    - well settings with plate loader, [6-14](#)
  - modifying well settings, [6-14](#)
    - applying existing well settings to additional wells, [6-15](#)
    - moving well location [with plate loader], [6-16](#)
  - movement
    - adjusting for autogates, [6-31](#)
    - autogate, [6-31](#)
  - moving
    - well location [with plate loader], [6-16](#)
  - MSDS (material safety data sheets)
    - how to order, [1-44](#)
  - multiple tube plots
    - export as picture files, [6-80](#)
  - multiple tube statistics table
    - export as picture files, [6-80](#)
  - mute
    - alarm, [1-19](#)
  - mute alerter icon, [1-19](#)
  - mW
    - define, [Abbreviations-2](#)
- ## N
- NA
    - define, [Abbreviations-2](#)
  - NaClO
    - define, [Abbreviations-2](#)
  - NaN3
    - define, [Abbreviations-2](#)
  - navigation
    - acquisition screen, [2-4](#)
    - QC screen, [2-13](#)
  - negative population
    - to define using unstained samples, [7-5](#)
  - new experiment
    - creating, [6-1](#)
  - new experiment with plate loader
    - creating, [6-1](#), [6-3](#)
  - nm
    - define, [Abbreviations-2](#)

- no changes occurred after manually adjusting compensation settings, [10-14](#)
- no data acquisition, [10-13](#)
- nonscheduled cleaning, [11-14](#)
- nonscheduled maintenance
  - adding the Deep Clean solution, [12-17](#)
  - calibrating the sample flow rate, [12-78](#)
  - calibrating the sample flow rate with plate loader, [12-82](#)
  - cleaning the sample probe, [11-8](#)
  - preparing the instrument for storage or transport, [11-15](#)
  - replacing the fuse, [12-90](#)
  - replacing the optical filter, [12-87](#)
- nonscheduled replacement/adjustment, [12-78](#)
- note
  - define, [xvii](#)
- Nt. Wt.
  - define, [Abbreviations-2](#)

## O

- open a compensation experiment
  - start page operations, [2-2](#)
- open an experiment
  - start page operations, [2-2](#)
- open software, [4-6](#)
- opening
  - analysis screen, [8-3](#)
- operating system patching, [G-53](#)
- optical
  - components, [1-4](#)
- optical bench
  - optical component, [1-4](#)
- optical components
  - detector (WDM), [1-4](#)
  - optical bench, [1-4](#)
  - optical fiber, [1-4](#)
- optical fiber, [1-16](#)
- optical filter, [1-5](#)
  - to replace, [12-87](#)
- ordering
  - customer-replaceable parts, [H-1](#)
- ordering information, [1-35](#)
- overlay dot plots, [2-34](#)
- overlay histograms, [2-34](#)
- overview
  - document, [xli](#)

## P

- page setup settings, [2-47](#)
- parameter (heat map)
  - delete, [6-65](#)
- parameters
  - description, [3-7](#)
  - duplicating standardization items, [5-45](#)
  - editing standardization items, [5-45](#)
  - instrument, [1-38](#)
  - TIME, [3-7](#)
- password
  - change, [2-27](#)
  - default, [2-24](#), [A-24](#)
  - reset, [2-27](#)
- PB
  - define, [Abbreviations-2](#)
- PC5
  - define, [Abbreviations-2](#)
- PC5.5
  - define, [Abbreviations-2](#)
- PC7
  - define, [Abbreviations-2](#)
- PE
  - define, [Abbreviations-2](#)
- PEEK
  - define, [Abbreviations-2](#)
- PerCP
  - define, [Abbreviations-2](#)
- performance characteristics, [1-41](#)
  - sample injection mode control knob, [C-1](#)
- performing
  - daily quality control, [5-1](#)
- PI
  - define, [Abbreviations-2](#)
- picture files
  - to export, [6-80](#)
- plate holder
  - components, [1-27](#)
- plate holder with plate loader
  - replacing, [12-65](#)
- plate loader
  - components, [1-23](#)
- Plate Loader module
  - installing, [12-67](#)
  - removing, [12-67](#)
- plate loader PEEK tubing
  - replacing, [12-48](#)
- plate loader PEEK tubing (replacing)
  - routine maintenance, [12-48](#)

- plate position [with plate loader]
    - calibrating, [12-95](#)
  - plate type, [2-36](#)
  - plate type library, [2-36](#)
  - plot area
    - acquisition screen, [2-8](#)
  - plot display conditions
    - to set, [6-46](#)
  - plot settings, [2-46](#)
  - plots
    - dual-parameter, [2-34](#)
    - overlay dot plots, [2-34](#)
    - overlay histograms, [2-34](#)
    - single-parameter, [2-34](#)
    - to create, [6-19](#)
    - to set, [8-3](#)
    - types of display, [3-7](#)
  - PN
    - define, [Abbreviations-2](#)
  - policies
    - account, [2-31](#)
  - pollution degree, [1-38](#)
  - polygon gates
    - for dual-parameter plots, [2-35](#)
  - population amplitude is decreasing and CV
    - values are increasing, [10-12](#)
  - populations are drifting, [10-12](#)
  - position
    - sample tube holder, [1-22](#)
  - power source
    - installation environment validation, [A-3](#)
  - power source inspection
    - pre-boot, [4-5](#)
  - power switch
    - electronic devices, [1-32](#), [1-34](#)
  - pre-boot inspection, [4-1](#)
    - check waste and reagent levels (10 L fluid cubitainers), [4-4](#)
    - check waste and reagent levels (4 L fluid containers), [4-2](#)
    - power source inspection, [4-5](#)
    - workstation connections inspection, [4-5](#)
  - precaution
    - disposal, [10-9](#)
  - precautions
    - safety, [-xviii](#)
  - precautions/hazards, [10-1](#)
  - preparation process
    - QC sample (CytoFLEX Daily IR QC Fluorospheres), [5-4](#)
    - QC sample (CytoFLEX Daily IR QC Fluorospheres) with plate loader, [5-6](#)
    - QC sample (CytoFLEX Daily QC Fluorospheres), [5-3](#), [5-28](#)
    - QC sample (CytoFLEX Daily QC Fluorospheres) with plate loader, [5-5](#)
    - QC sample (CytoFLEX Ready to Use Daily QC Fluorospheres), [5-4](#), [5-6](#)
  - preparing
    - compensation sample, [7-4](#), [7-13](#)
    - Deep Clean solution, [12-17](#)
    - instrument for storage or transport, [11-15](#)
    - QC sample, [5-3](#)
    - QC sample with plate loader, [5-5](#)
    - Standardization sample, [5-27](#)
    - the cleaning solution, [9-1](#)
  - preparing QC sample
    - required materials, [5-3](#), [5-28](#)
  - preparing QC sample with plate loader
    - required materials, [5-5](#)
  - press
    - conventions, [xliii](#)
  - previously acquired data
    - to import, [8-1](#)
  - previously acquired experiment
    - to copy, [8-1](#)
  - priming
    - flow cell, [12-64](#)
  - print
    - experiment signature, [B-25](#)
  - printing
    - graphics, [6-83](#)
  - procedure
    - Deep Clean, [11-9](#)
  - product description, [1-1](#)
- ## Q
- QC
    - applying standardization, [5-38](#), [5-41](#)
    - define, [Abbreviations-2](#)
    - result manager, [5-26](#)
    - standardization, [5-28](#)
  - QC aborted due to low event rate, [10-17](#)
  - QC data
    - collecting, [5-12](#)
  - QC data with plate loader
    - collecting, [5-15](#)
  - QC experiment screen, [2-12](#), [2-13](#)

- QC failed, [10-18](#)
  - QC menu tree
    - software, [2-15](#)
  - QC report screen, [2-12](#)
  - QC sample
    - preparation, [5-3](#)
  - QC sample (CytoFLEX Daily IR QC Fluorospheres)
    - preparation process, [5-4](#)
  - QC sample (CytoFLEX Daily IR QC Fluorospheres) with plate loader
    - preparation process, [5-6](#)
  - QC sample (CytoFLEX Daily QC Fluorospheres)
    - preparation process, [5-3](#), [5-28](#)
  - QC sample (CytoFLEX Daily QC Fluorospheres) with plate loader
    - preparation process, [5-5](#)
  - QC sample (CytoFLEX Ready to Use Daily QC Fluorospheres)
    - preparation process, [5-4](#), [5-6](#)
  - QC sample with plate loader
    - preparation, [5-5](#)
  - QC screen
    - navigation, [2-13](#)
  - QC software menu tree, [2-15](#)
  - QC/Standardization menu, [2-20](#)
  - Quality Control, [5-2](#)
  - quality control, [5-2](#)
    - perform daily, [5-1](#)
  - quality control (QC)
    - define, [5-1](#)
- R**
- radiation
    - hazards, [10-3](#)
  - RAM
    - define, [Abbreviations-2](#)
  - rCV
    - define, [Abbreviations-2](#)
  - reagent levels (10 L fluid cubitainers)
    - check, [4-4](#)
  - reagent levels (4 L fluid containers)
    - check, [4-2](#)
  - recovery key, [G-13](#)
  - rectangle gates
    - for dual-parameter plots, [2-35](#)
  - refreshing
    - heat map (plate loader), [6-70](#)
  - reinstall
    - CytExpert software, [A-29](#)
    - reinstallation procedures
      - right-side cover, [12-5](#)
    - removal procedures
      - front cover, [12-2](#)
      - right-side cover, [12-4](#)
    - removing
      - Plate Loader module, [12-67](#)
    - rename
      - experiment directory (electronic record management), [B-4](#)
    - replacement
      - nonscheduled, [12-78](#)
      - routine, [12-2](#)
    - replacing
      - 10 L sheath fluid cubitainer, [12-7](#)
      - fuse, [12-90](#)
      - optical filter, [12-87](#)
      - plate holder with plate loader, [12-65](#)
      - plate loader PEEK tubing, [12-48](#)
      - sample peristaltic pump tubing for sample loading, [12-38](#)
      - sheath fluid filter, [12-18](#)
      - sheath fluid harness and/or waste harness, [12-91](#)
    - replacing sheath fluid cubitainer, [4-4](#)
    - replacing the peristaltic pump for sample loading
      - routine maintenance, [12-38](#)
    - replacing the sample probe for plate loader
      - routine maintenance, [12-48](#)
    - replacing the sheath fluid filter
      - routine maintenance, [12-18](#)
    - required materials
      - QC sample preparation, [5-3](#), [5-28](#)
      - QC sample preparation with plate loader, [5-5](#)
      - software installation, [A-13](#)
    - reset
      - password, [2-27](#)
    - restore, [10-20](#)
    - result manager
      - QC, [5-26](#)
    - results
      - confirming, [5-20](#)
      - to export, [8-9](#)
    - retention period
      - setting, [B-21](#)
    - retract
      - electronic signature, [B-20](#)
  - RH

- define, [Abbreviations-2](#)
  - right-side cover
    - reinstallation, [12-5](#)
    - removal, [12-4](#)
  - RoHS
    - define, [Abbreviations-2](#)
  - role management, [2-27](#)
  - roles
    - creating, [2-29](#)
    - deleting, [2-30](#)
    - modifying, [2-30](#)
  - routine cleaning, [11-1](#)
  - routine maintenance
    - cleaning the 4 L sheath fluid container, [11-11](#)
    - cleaning the 4 L waste container, [11-12](#)
    - cleaning the sample station, [11-7](#)
    - daily startup and shutdown, [11-1](#)
    - daily startup and shutdown with plate loader, [11-5](#)
    - Deep Clean, [11-9](#)
    - liquid flow tubing inspection, [12-63](#)
    - replacing the plate loader PEEK tubing, [12-48](#)
    - replacing the sample peristaltic pump tubing for sample loading, [12-38](#)
    - replacing the sheath fluid filter, [12-18](#)
  - routine replacement/adjustment, [12-2](#)
  - RPTM
    - define, [Abbreviations-2](#)
  - running
    - single positive control samples, [7-6](#)
    - system startup program, [4-16](#)
    - system startup program with plate loader, [4-19](#)
  - running small sample volumes
    - manual injection mode, [4-10](#)
- S**
- S/N
    - define, [Abbreviations-2](#)
  - safety
    - precautions, [-xviii](#)
  - sample
    - checks before running, [6-47](#)
    - flow, description, [3-1](#)
    - illuminated in the flow cell, [3-4](#)
    - loading, automated, [3-1](#)
  - sample acquisition position
    - sample tube holder position, [1-22](#)
  - sample carousel
    - bar-code labels, [3-1](#)
    - description, [3-1](#)
    - See also* carousel, sample and MCL
  - sample flow
    - description, [3-1](#)
  - sample flow rate
    - calibrating, [12-78](#)
  - sample flow rate is unstable, [10-11](#)
  - sample flow rate with plate loader
    - calibrating, [12-82](#)
  - sample injection control knob
    - performance characteristics, [C-1](#)
  - sample injection mode
    - selecting, [4-9](#)
  - sample injection mode control kit
    - components, [C-2](#)
  - sample is flowing, but no signal appears in the plot, [10-15](#)
  - sample loading
    - backup, [4-10](#)
  - sample loading position
    - sample tube holder position, [1-22](#)
  - sample peristaltic pump tubing
    - to replace, [12-38](#)
  - sample peristaltic pump tubing for sample loading
    - to replace, [12-38](#)
  - sample peristaltic pump tubing for sample loading (replacing)
    - routine maintenance, [12-38](#)
  - sample probe
    - to clean, [11-8](#)
    - to unclog, [12-22](#), [12-31](#)
  - sample probe change
    - from plate loader to single tube sample station, [12-59](#)
    - from single tube sample station to plate loader, [12-54](#)
  - sample probe for plate loader
    - replacing, [12-48](#)
  - sample probe for sample loading
    - to replace, [12-22](#), [12-31](#)
  - sample probe for sample loading (unclogging)
    - routine maintenance, [12-22](#), [12-31](#)
  - sample probe is too low, [10-16](#)
  - sample probe switch
    - from plate loader to single tube sample station, [C-5](#)

- from single tube sample station to plate loader, C-3
- sample station, 1-21
  - to clean, 11-7
- sample station (cleaning)
  - routine maintenance, 11-7
- sample tube holder cannot move up and down
  - automatically, 10-11
- sample tube holder position
  - sample acquisition position, 1-22
  - sample loading position, 1-22
  - standby position, 1-22
- sample wells with plate loader
  - setting, 6-9
- sampling
  - data, 6-58
- sampling flow rate is too fast, 10-12
- saving
  - experiment, 6-86
- screen
  - acquisition, 2-3
  - analysis, 2-9, 8-1, 8-3
  - compensation experiment, 2-11
  - QC experiment, 2-12, 2-13
  - QC report, 2-12
  - software, 2-1
- SDS (safety data sheets)
  - how to order, 1-44
- select
  - conventions, xliiii
- selecting
  - detector configuration, 6-48
  - proper sample injection mode, 4-9
- service, contact information, ii
- setting
  - channel, 6-16
  - channels, 6-16
  - collection conditions, 6-44
  - custom statistics, 6-35
  - customized parameters, 6-33
  - labels, 6-16
  - laser delay, 12-86
  - laser target power settings (CytoFLEX LX only), 6-40
  - plot display conditions, 6-46
  - retention period, B-21
  - sample wells with sample wells, 6-9
  - signature, B-22
  - the plots and statistics, 8-3
- setting up
  - violet side scatter channel (VSSC), 6-55
- settings
  - acquisition, 6-38
  - experiment, 2-45
  - gate, 2-47
  - language, 2-48
  - laser, 6-38
  - page setup, 2-47
  - plot, 2-46
  - software, 2-45
  - tube, 2-46
- settings menu, 2-19
- setup
  - CytExpert API test client, 2-48
  - experiment directory (electronic record management), B-3
- sheath fluid container, 1-17
  - to fill, 4-2
- sheath fluid container 4 L (CytoFLEX)
  - filling, 12-6
- sheath fluid container/cubitainer, 1-18
- sheath fluid cubitainer
  - to replace, 4-4
- sheath fluid cubitainer 10 L
  - replacing, 12-7
- sheath fluid filter
  - to replace, 12-18
- sheath fluid filter (replacing)
  - routine maintenance, 12-18
- sheath fluid filters
  - fluidics module, 1-19
- sheath fluid harness and sensor, 1-17, 1-18
- sheath fluid in
  - fluidic connection, 1-20, 4-3, 4-5
- sheath fluid level sensor connector
  - fluidic connection, 1-20, 4-3, 4-5
- sheath return
  - fluidic connection, 1-20, 4-3, 4-5
- shut off
  - the instrument, 9-2
- shutdown
  - automatic, 6-8, 9-3, 11-7
- shutdown daily
  - routine maintenance, 11-1
- shutdown daily with plate loader
  - routine maintenance, 11-5
- side scatter (SS)
  - cell illumination, 3-4
  - collection, 3-5
  - when to use, example, 3-4

- sign
  - experiment, [B-17](#)
- signals
  - processing of, operation principles, [3-6](#)
- signature
  - setting, [B-22](#)
- signature menu, [2-22](#)
- single positive control samples
  - to run, [7-6](#)
- single-parameter plots, [2-34](#)
- SNR
  - define, [Abbreviations-2](#)
- software
  - functions, [2-1](#)
  - launching, [2-1](#)
  - log in, [4-6](#)
  - main screen, [2-1](#)
  - open, [4-6](#)
  - to install, [A-13](#)
  - to start, [A-24](#)
- software installation, [A-12](#)
  - installing CytExpert software, [A-13](#)
  - installing instrument configuration file, [A-22](#)
  - required materials, [A-13](#)
  - starting the software, [A-24](#)
- software installation fails, [10-16](#)
- software menu, [2-14](#)
  - acquisition and analysis screen menu, [2-15](#)
  - electronic record management, [B-1](#)
- software menu tree, [2-14](#)
- software operations
  - create a new experiment, [2-2](#)
- software screen, [2-1](#)
  - start page, [2-2](#)
  - start page operations, [2-2](#)
- software settings, [2-45](#)
- specifications
  - characteristics, [1-36](#)
  - instrument, [1-36](#)
- specimen
  - See sample
- SS
  - See side scatter
- SSC
  - define, [Abbreviations-2](#)
- Standardization
  - loading standardization sample, [5-28](#)
  - Target value, [5-28](#)
- standardization, [5-27](#)
  - applying in QC, [5-38](#), [5-41](#)
- standardization item
  - adding, [5-34](#)
  - deleting, [5-46](#)
  - exporting, [5-45](#)
  - importing, [5-44](#)
- standardization item parameters
  - duplicating, [5-45](#)
  - editing, [5-45](#)
- Standardization sample
  - preparation, [5-27](#)
- standardization target library
  - deleting standardization target settings, [5-44](#)
  - duplicate standardization target settings, [5-44](#)
  - editing standardization target settings, [5-44](#)
  - exporting standardization target settings, [5-44](#)
  - importing standardization target settings, [5-44](#)
- standby position
  - sample tube holder position, [1-22](#)
- start page
  - main software screen, [2-2](#)
  - selecting experiments, [4-27](#)
- start page operations
  - create a compensation experiment, [2-2](#)
  - create a new experiment from a template, [2-2](#)
  - exit the software, [2-2](#)
  - main software screen, [2-2](#)
  - open a compensation experiment, [2-2](#)
  - open an experiment, [2-2](#)
- starting
  - the software, [A-24](#)
- startup
  - automatic, [9-3](#)
- startup daily
  - routine maintenance, [11-1](#)
- startup daily with plate loader
  - routine maintenance, [11-5](#)
- station
  - sample, [1-21](#)
- statistics
  - setting, [3-8](#)
  - to set, [8-3](#)
- status bar

- acquisition screen, [2-9](#)
- storing the instrument, [A-1](#)
- support, Beckman Coulter customer, [ii](#)
- surface
  - cleaning and disinfection, [11-14](#)
- suspending BitLocker drive encryption, [G-21](#)
- switching sample probe
  - from plate loader to single tube sample station, [C-5](#)
  - from single tube sample station to plate loader, [C-3](#)
- symbols
  - define, [-xix](#)
- system configuration, [1-31](#)
- system operation log
  - electronic record management, [B-15](#)
- system startup program
  - to run, [4-16](#)
- system startup program with plate loader running, [4-19](#)

## T

- table
  - troubleshooting, [10-9](#)
- target power settings (CytoFLEX LX only)
  - laser, [6-40](#)
- target value
  - Standardization, [5-28](#)
- temperature and humidity
  - installation environment validation, [A-4](#)
- test tubes
  - acquisition screen, [2-7](#)
- the term press
  - conventions, [xliv](#)
- the term select
  - conventions, [xliv](#)
- threshold
  - to adjust, [6-43](#)
- TIME parameter
  - description, [3-7](#)
- transporting the instrument, [A-1](#)
- troubleshooting, [10-1](#)
  - alarm does not sound when the waste container is full or the sheath fluid container is low and the software status display is red, [10-10](#)
  - calculation of the automatic compensation experiment is incorrect, [10-14](#)
  - concentration calculation is incorrect, [10-15](#)

- connection indicator light in the lower left corner of the software screen is red and displays Disconnected and Error, [10-10](#)
- Cytometer cannot be turned on, [10-9](#)
- data populations are normal on one laser, but too low on another laser, [10-13](#)
- data populations are not where they are expected, [10-14](#)
- fluid status information displays red for Sheath and/or Waste even though the sheath fluid container is full and the waste container is empty, [10-11](#)
- instrument operations cannot be performed in the Acquisition screen, [10-16](#)
- laser delay values are out of range, [10-13](#)
- laser power is low, [10-12](#)
- mixer is not functioning, [10-16](#)
- no changes occurred after manually adjusting compensation settings, [10-14](#)
- no data acquisition, [10-13](#)
- population amplitude is decreasing and CV values are increasing, [10-12](#)
- populations are drifting, [10-12](#)
- QC aborted due to low event rate, [10-17](#)
- QC failed, [10-18](#)
- sample flow rate is unstable, [10-11](#)
- sample is flowing, but no signal appears in the plot, [10-15](#)
- sample probe is too low, [10-16](#)
- sample tube holder cannot move up and down automatically, [10-11](#)
- sampling flow rate is too fast, [10-12](#)
- software installation fails, [10-16](#)
- table, [10-9](#)
- wash station drips during backflush, [10-16](#)
- Workstation cannot be turned on, [10-9](#)
- tube
  - settings, [2-46](#)
- tube name
  - to change, [6-38](#)
- turn off
  - auto recalculate, [6-30](#)
- turn on
  - auto recalculate, [6-30](#)
- turning the power on, [4-6](#)

## U

- unclogging
  - sample probe for sample loading, [12-22](#),

- 12-31
  - unlock
    - user account, 2-27
  - unpacking inspection, A-4
    - check instrument configuration, A-4
    - installing the instrument and connecting the equipment, A-5, A-11
  - unpacking the instrument, A-4
  - unstained samples
    - to define the negative population, 7-5
  - upgrade
    - CytExpert software, A-24
  - USB
    - define, Abbreviations-2
  - use your manual
    - how to, xli
  - user account
    - unlock, 2-27
  - user management, 2-23
    - electronic record management, B-26
  - user management operation
    - log, 2-33
  - user management operation log
    - electronic record management, B-16
  - user roles
    - creating, 2-29
    - deleting, 2-30
    - modifying, 2-30
  - users
    - creating, 2-25
    - deleting, 2-26
    - modifying, 2-26
  - using unstained samples, 7-5
  - UV
    - define, Abbreviations-2
- V**
- V
    - define, Abbreviations-2
  - VA
    - define, Abbreviations-2
  - VAC
    - define, Abbreviations-2
  - ventilation and cleaning
    - installation environment validation, A-2
  - verifying
    - detector configuration, 6-48
  - vertex
    - add to auto polygon gate, 6-30
  - vertical gates
    - for single-parameter plots, 2-35
  - viewing
    - user logs, 2-33
  - violet side scatter channel (VSSC)
    - to set up, 6-55
  - VSSC
    - define, Abbreviations-2
- W**
- W
    - define, Abbreviations-2
  - warning
    - define, xvii
  - wash station drips during backflush, 10-16
  - waste container, 1-17
  - waste container 4 L (CytoFLEX)
    - emptying, 12-9
  - waste container/cubitainer, 1-18
  - waste cubitainer 10 L (CytoFLEX LX)
    - emptying, 12-10
  - waste disposal, A-4
  - waste fluid harness and sensor, 1-17, 1-18
  - waste harness
    - to replace, 12-91
  - waste level sensor connector
    - fluidic connection, 1-20, 4-3, 4-5
  - waste levels (10 L fluid cubitainers)
    - check, 4-4
  - waste levels (4 L fluid containers)
    - check, 4-2
  - waste out
    - fluidic connection, 1-20, 4-3, 4-5
  - wavelength
    - laser, 1-38
  - wavelength division multiplexer (WDM), 1-5
  - WDM
    - define, Abbreviations-2
  - WDM beam splitter
    - exchange detector configuration, F-4
  - well settings with plate loader
    - modifying, 6-14
  - copying
    - wells, 6-15
  - cutting
    - wells, 6-15
  - modifying well settings
    - copying wells, 6-15
    - cutting wells, 6-15

- pasting wells, [6-15](#)
- pasting
  - wells, [6-15](#)
- running
  - samples, [6-61](#)
- sample, [6-61](#)
- sample injection mode
  - selecting, [4-12](#)
- selecting
  - proper sample injection mode, [4-12](#)
- routine maintenance
  - unclogging the sample probe, [12-22](#)
- unclogging the sample probe, [12-22](#)
- routine maintenance
  - unclogging the sample probe, [12-31](#)
- unclogging the sample probe, [12-31](#)
- Workstation, [1-2](#), [1-3](#), [A-6](#)
  - component, [1-2](#)
- Workstation cannot be turned on, [10-9](#)
- workstation connections inspection
  - pre-boot, [4-5](#)
- worktable
  - installation environment validation, [A-2](#)



# Beckman Coulter, Inc.

## SOFTWARE END-USER LICENSE AGREEMENT

IMPORTANT: READ THIS END-USER LICENSE AGREEMENT:

THIS END-USER LICENSE AGREEMENT (“*Agreement*”) GOVERNS THE USE OF CERTAIN COMPUTER PROGRAMS ASSOCIATED WITH THE CORRESPONDING PRODUCT (“*Product*”) OF BECKMAN COULTER, INC. OR ITS AFFILIATES (“*BCI*”). YOUR USE OF SUCH COMPUTER PROGRAMS, YOUR PURCHASE OF THE PRODUCT, AND/OR YOUR USE OF THE PRODUCT CONSTITUTES ASSENT AND ACCEPTANCE OF THIS AGREEMENT BY YOU (collectively “*You*” or “*Your*”) AND SIGNIFIES YOUR AGREEMENT TO BE BOUND BY THE TERMS AND CONDITIONS OF THIS AGREEMENT. IF YOU DO NOT AGREE WITH ALL OF THE TERMS AND CONDITIONS OF THIS AGREEMENT, YOU DO NOT HAVE THE RIGHT TO AND MAY NOT USE THE COMPUTER PROGRAMS PROVIDED.

1. **GRANT OF LICENSE.** Subject to all of the terms and conditions of this Agreement, BCI grants to You a non-exclusive, non-sub licensable license to use the computer programs provided by BCI (“*Programs*”) in connection with and/or installed on the Product, and the associated user documentation (“*Documentation*”) (together with the Programs referred to herein, collectively, as the (“*Software*”)), only in accordance with the Documentation (“*License*”). You have no right to receive, use or examine any source code or design documentation relating to the Programs. The Software is licensed and not sold. As between the parties, BCI and its licensor retains all right, title and interest in and to the Software and any and all derivative works, except as expressly and unambiguously licensed herein, and BCI reserves all rights in the Software not granted to You. Except as otherwise expressly provided under the Agreement, You shall only use the Software for Your internal research and development purposes.
2. **USE RESTRICTIONS.** You shall not (and shall not allow others to), directly or indirectly:
  - a. use (including make any copies of) the Programs beyond the scope of the license granted under Section 1.;
  - b. modify, translate, adapt, or otherwise create derivative works or improvements, whether or not patentable, of the Programs or any part thereof;
  - c. combine the Programs or any part thereof with, or incorporate the Programs or any part thereof in, any other programs;
  - d. reverse engineer, disassemble, decompile, decode, or otherwise attempt to derive or gain access to the source code of the Programs or any part thereof;
  - e. reverse engineer, disassemble, decompile, decode, or otherwise attempt to derive or gain access to the object code of the Programs or any part thereof;
  - f. remove, delete, alter, or obscure any trademarks or any copyright, trademark, patent, or other intellectual property or proprietary rights notices provided on or with the Software, including any copy thereof;
  - g. rent, lease, lend, sell, sub license, assign, distribute, publish, transfer, or otherwise make available the Programs, or any features or functionality of the Programs, to any third party for any reason, whether or not over a network or on a hosted basis, including in connection with the Internet or any web hosting, wide area network (WAN), virtual private network (VPN), virtualization, time-sharing, service bureau, software as a service, cloud, or other technology or service;
  - h. use the Software in, or in association with, the design, construction, maintenance, or operation of any hazardous environments or systems;
  - i. use the Software in violation of any law, regulation, or rule; or

- j. use the Software for purposes of competitive analysis of the Programs, the development of a competing software product or service, or any other purpose that is to BCI's commercial disadvantage.
3. **TERMINATION.** The License is effective until terminated. You may terminate the Agreement and the License at any time by destroying all copies of the Programs. The License will terminate automatically without notice if You fail to comply with any provision of this Agreement. Within fourteen (14) days following termination, You shall cease all use of, and, destroy all copies of the Software in Your possession or control and so certify to BCI in writing. Except for the License, the terms of this Agreement shall survive termination. Termination is not an exclusive remedy and all other remedies will be available to BCI whether or not the License is terminated.
4. **SOFTWARE SUPPORT.** Please refer to the BCI support number provided in the Documentation for the Product for information regarding support of the Product.
5. **DISCLAIMER OF WARRANTY.** THE SOFTWARE IS PROVIDED TO YOU "AS IS" AND WITH ALL FAULTS AND DEFECTS WITHOUT WARRANTY OF ANY KIND. TO THE MAXIMUM EXTENT PERMITTED UNDER APPLICABLE LAW, BCI, ON ITS OWN BEHALF AND ON BEHALF OF ITS AFFILIATES AND ITS AND THEIR RESPECTIVE LICENSORS AND SERVICE PROVIDERS, EXPRESSLY DISCLAIMS ALL WARRANTIES, WHETHER EXPRESS, IMPLIED, STATUTORY, OR OTHERWISE, WITH RESPECT TO THE SOFTWARE, INCLUDING ALL IMPLIED WARRANTIES OF MERCHANTABILITY, FITNESS FOR A PARTICULAR PURPOSE, TITLE, AND NON-INFRINGEMENT, AND WARRANTIES THAT MAY ARISE OUT OF COURSE OF DEALING, COURSE OF PERFORMANCE, USAGE, OR TRADE PRACTICE. WITHOUT LIMITATION TO THE FOREGOING, BCI PROVIDES NO WARRANTY OR UNDERTAKING, AND MAKES NO REPRESENTATION OF ANY KIND THAT THE LICENSED SOFTWARE WILL MEET YOUR REQUIREMENTS, ACHIEVE ANY INTENDED RESULTS, BE COMPATIBLE, OR WORK WITH ANY OTHER SOFTWARE, APPLICATIONS, SYSTEMS, OR SERVICES, OPERATE WITHOUT INTERRUPTION, MEET ANY PERFORMANCE OR RELIABILITY STANDARDS OR BE ERROR FREE, OR THAT ANY ERRORS OR DEFECTS CAN OR WILL BE CORRECTED.
6. **LIMITATION OF LIABILITY.** TO THE FULLEST EXTENT PERMITTED UNDER APPLICABLE LAW:
  - a. IN NO EVENT WILL BCI OR ITS AFFILIATES, OR ANY OF ITS OR THEIR RESPECTIVE LICENSORS OR SERVICE PROVIDERS, BE LIABLE TO YOU OR ANY THIRD PARTY FOR ANY USE, INTERRUPTION, DELAY, OR INABILITY TO USE THE SOFTWARE; LOST REVENUES OR PROFITS; DELAYS, INTERRUPTION, OR LOSS OF SERVICES, BUSINESS, OR GOODWILL; LOSS OR CORRUPTION OF DATA; LOSS RESULTING FROM SYSTEM OR SYSTEM SERVICE FAILURE, MALFUNCTION, OR SHUTDOWN; FAILURE TO ACCURATELY TRANSFER, READ, OR TRANSMIT INFORMATION; FAILURE TO UPDATE OR PROVIDE CORRECT INFORMATION; SYSTEM INCOMPATIBILITY OR PROVISION OF INCORRECT COMPATIBILITY INFORMATION; OR BREACHES IN SYSTEM SECURITY; OR FOR ANY CONSEQUENTIAL, INCIDENTAL, INDIRECT, EXEMPLARY, SPECIAL, OR PUNITIVE DAMAGES, WHETHER ARISING OUT OF OR IN CONNECTION WITH THIS AGREEMENT, BREACH OF CONTRACT, TORT (INCLUDING NEGLIGENCE), OR OTHERWISE, REGARDLESS OF WHETHER SUCH DAMAGES WERE FORESEEABLE AND WHETHER OR YOU WERE ADVISED OF THE POSSIBILITY OF SUCH DAMAGES;
  - b. IN NO EVENT WILL THE COLLECTIVE AGGREGATE LIABILITY OF BCI AND ITS AFFILIATES, INCLUDING ANY OF THEIR RESPECTIVE LICENSORS AND SERVICE PROVIDERS, UNDER OR IN CONNECTION WITH THIS AGREEMENT OR ITS SUBJECT MATTER, UNDER ANY LEGAL OR EQUITABLE THEORY, INCLUDING BREACH OF CONTRACT, TORT (INCLUDING NEGLIGENCE), STRICT LIABILITY, AND OTHERWISE, EXCEED TWO HUNDRED AND FIFTY DOLLARS (US\$250); AND

- c. THE LIMITATIONS SET FORTH IN THIS SECTION 6. SHALL APPLY EVEN IF YOUR REMEDIES UNDER THIS AGREEMENT FAIL OF THEIR ESSENTIAL PURPOSE.
7. **U.S. GOVERNMENT RIGHTS.** The Software is commercial computer software, as such term is defined in 48 C.F.R. §2.101. Accordingly, if You are the US Government or any contractor therefor, You shall receive only those rights with respect to the Software as are granted to all other end users under license, in accordance with
- a. 48 C.F.R. §227.7201 through 48 C.F.R. §227.7204, with respect to the Department of Defense and their contractors, or
  - b. 48 C.F.R. §12.212, with respect to all other US Government licensees and their contractors.
8. **EXPORT REGULATION.** The Software may be subject to US export control laws, including the US Export Administration Act and its associated regulations. You shall not, directly or indirectly, export, re-export, or release the Software to, or make the Software accessible from, any jurisdiction or country to which export, re-export, or release is prohibited by law, rule, or regulation. You shall comply with all applicable federal laws, regulations, and rules, and complete all required undertakings (including obtaining any necessary export license or other governmental approval), prior to exporting, re-exporting, releasing, or otherwise making the Software available outside the US.
9. **INTELLECTUAL PROPERTY RIGHTS.** You acknowledge and agree that the Software is provided under license, and not sold, to You. You do not acquire any ownership interest in the Software under this Agreement, or any other rights thereto, other than to use the same in accordance with the license granted and subject to all terms, conditions, and restrictions under this Agreement. BCI shall retain its entire right, title, and interest in and to the Software and all intellectual property rights arising out of or relating to the Software, except as expressly granted to You in this Agreement. You shall use commercially reasonable efforts to safeguard all Software (including all copies thereof) from infringement, misappropriation, theft, misuse, or unauthorized access.
10. **THIRD PARTY COMPONENTS; ADDITIONAL TERMS.** The Software may contain or be delivered with one or more components, which may include third-party components, identified by BCI in the Documentation, readme.txt file, third-party click-accept or elsewhere (e.g., on [www.beckman.com](http://www.beckman.com) or attached to this Agreement as an appendix) (the “Identified Component(s)”) as being subject to different license agreement terms, disclaimers of warranties, limited warranties or other terms and conditions (collectively, “Additional Terms”) than those set forth herein. You agree to the applicable Additional Terms for any such Identified Component(s).
11. **MISCELLANEOUS.** You may not assign this Agreement or any of Your rights hereunder without BCI's prior written consent and any attempt to do so without such consent shall cause this Agreement and any of Your associated rights hereunder to be null and void. No failure to exercise any right hereunder will operate as a waiver thereof. If any provision of this Agreement shall be adjudged by any court of competent jurisdiction to be unenforceable or invalid, that provision shall be limited or eliminated to the minimum extent necessary so that this Agreement shall otherwise remain in full force and effect and enforceable. This Agreement shall be construed in accordance with the laws of the State of California and the United States without regard to conflicts of laws provisions thereof and without regard to the United Nations Convention on Contracts for the International Sale of Goods. The sole and exclusive jurisdiction and venue for any actions related to the subject matter hereof shall be the state and U.S. federal courts located in the County of Orange, California. You irrevocably submit to the jurisdiction of such courts and consent to venue in such forum with respect to any action or proceeding that relates to this Agreement. The prevailing party in any action to enforce this Agreement shall be entitled to recover its reasonable costs and expenses including reasonable attorneys' fees. No amendment to or modification of this Agreement will be binding unless in writing and signed by a duly authorized officer of BCI. This Agreement is in the English language only, which language shall be controlling and any revision of this Agreement in any other language shall not be binding. Both parties agree that this Agreement is the complete and exclusive statement of the mutual understanding of the parties relating to the subject matter of this Agreement.





# Related Documents

**CytoFLEX Instructions for Use**  
PN B49006

[www.beckman.com](http://www.beckman.com)

