



# Leica DMI 6000 B

Operating Manual

*Leica*  
MICROSYSTEMS

Published October 2004 by:

Leica Microsystems Wetzlar GmbH  
Ernst-Leitz-Straße  
D-35578 Wetzlar (Germany)

Responsible for contents:

Bernard Kleine  
(Marketing CM, Compound Microscopy, Product Management)

Holger Grasse

(Safety Officer according to MPG §30)

In case of questions, please contact the hotline:

Phone +49(0)6441-292286

Fax +49(0)6441-292255

E-mail: [MQM-Hotline@leica-microsystems.com](mailto:MQM-Hotline@leica-microsystems.com)



# Leica DMI6000 B

Operating Manual

*Leica*  
MICROSYSTEMS

# Copyrights

All rights to this documentation are held by Leica Microsystems Wetzlar GmbH. Reproduction of text or illustrations (in whole or in part) by print, photocopy, microfilm or other method (including electronic systems) is not allowed without express written permission from Leica Microsystems Wetzlar GmbH.

The term "Windows" may appear in the following text without further identification. It is, however, a registered trademark of Microsoft Corporation. The names of companies and products used herein may be trademarks of their respective owners.

The instructions contained in the following documentation reflect state-of-the-art technology and knowledge standards. We have compiled the texts and illustrations as accurately as possible. Nevertheless, no liability of any kind may be assumed for the accuracy of this manual's contents. Still, we are always grateful for comments and suggestions regarding potential mistakes within this documentation.

The information in this manual is subject to modification at any time and without notification.

# Contents

<b>1. Important Notes about this Manual .....</b>	<b>7</b>	6.11 Installation of Lamp Housing Mount and Mirror Housing .....	42
<b>2. Intended Purpose of the Microscope ...</b>	<b>8</b>	6.12 Installation and Replacement of Incident Light Lamps .....	44
<b>3. Safety Notes .....</b>	<b>9</b>	6.13 Equipping the Incident Light Turret Disk .....	48
3.1 General Safety Notes .....	9	6.14 Installation of the Polarizer and Analyzer .....	50
3.2 Electrical Safety .....	10	6.15 Optional Accessories .....	52
<b>4. Overview of the Leica DMI 6000 B .....</b>	<b>12</b>	6.16 Connection to the Electronics Box CTR6000 .....	53
4.1 Specifications .....	12	6.17 Connection to the Computer .....	54
4.2 Glossary .....	16	6.18 Connection to the Power Supply .....	54
<b>5. Unpacking the Microscope .....</b>	<b>22</b>	<b>7. Start-up .....</b>	<b>55</b>
<b>6. Assembling the Microscope .....</b>	<b>25</b>	7.1 Functional Principle .....	55
6.1 Assembly Tools .....	25	7.2 Switching on the Microscope .....	59
6.2 Installation of the Transmitted Light Illumination Carrier (DL) .....	26	7.3 The LeicaScreen .....	60
6.3 Installation of the DIC Module and DIC Objective Prisms .....	27	7.4 The Function Buttons on the Stand .....	61
6.4 Installation of Specimen Stages .....	28	7.5 The SmartMove Remote Control Module .....	64
6.5 Installation of Condensers .....	34	7.6 Illumination .....	65
6.6 Installation of Eyepieces .....	39	7.6.1 Transmitted Light .....	65
6.7 Installation of Objectives .....	39	7.6.2 Incident Light - Fluorescence .....	68
6.8 Installation of Filters in the Illumination Arm .....	40	7.7 Checking Phase Contrast Rings .....	69
6.9 Installation of the Transmitted Light Lamp Housing .....	40	7.8 Setting the Motorized Polarizer .....	70
6.10 Installation and Replacement of the Transmitted Light Lamps: .....		7.9 Adjusting the Light Sources .....	71
Lamp Housing 107 or 107/2 .....	41		

<b>8. Operation .....</b>	<b>74</b>	<b>10. Care of the Microscope .....</b>	<b>95</b>
8.1 Switching On .....	74	10.1 Dust Cover .....	95
8.2. Contrast Methods .....	76	10.2 Cleaning .....	95
8.2.1 Brightfield (TL) .....	76	10.3 Handling Acids and Bases .....	96
8.2.2 Phase Contrast (TL) .....	77		
8.2.3 Darkfield (TL) .....	77	<b>11. Major Consumable and Replacement</b>	
8.2.4 Polarization (TL) .....	78	<b>Parts .....</b>	<b>97</b>
8.2.5 Differential			
Interference Contrast (TL) .....	79	<b>12. Dimensions .....</b>	<b>98</b>
8.3 Fluorescence .....	80	<b>13. Abbreviations and Pictograms .....</b>	<b>99</b>
8.4 Combination Methods .....	81	<b>14. Index .....</b>	<b>101</b>
8.5 Focusing .....	82	<b>15. EU Declaration of Conformity .....</b>	<b>104</b>
8.6 Tubes .....	84		
8.7 Eyepieces .....	85		
8.8 Objectives .....	85		
8.9 Stages and Object Displacement .....	88		
8.10 Magnification Changer .....	89		
8.11 Light Sources .....	89		
8.12 Aperture and			
Field Diaphragm .....	90		
<b>9. Troubleshooting .....</b>	<b>91</b>		

# 1. Important Notes about this Manual



**Caution!**

This operating manual is an essential component of the microscope, and must be read carefully before the microscope is assembled, put into operation or used.

This operating manual contains important instructions and information for the operational safety and maintenance of the microscope and accessories. It must therefore be kept safely for future reference.

A separate manual is available on CD-ROM covering the operation of the Leica Application Suite (LAS).

**Text symbols, pictograms and their meanings:**

(1.2)

Numbers in parentheses, such as "(1.2)", correspond to illustrations (in the example, Figure 1, Item 2).

→ p.20

Numbers with pointer arrows (for example → p.20), point to a certain page of this manual.



**Caution!**

Special safety instructions within this manual are indicated with the triangle symbol shown here, and have a gray background.



**Caution!** The microscope and accessories can be damaged when operated incorrectly.



Explanatory note.

\*

Item not contained in all configurations.

# 2. Intended Purpose of the Microscope

The Leica DMI 6000 B microscope described in these instructions is intended for biological routine and research applications. This includes the examination of samples taken from the human body to provide information on physiological or pathological states or congenital abnormalities, or determining the safety and compatibility with potential recipients, or monitoring therapeutic measures.

The Leica DMI 6000 B is a further development of Leica's proven inverted research microscopes. It is designed for cellular and tissue examination, micromanipulation and microinjection techniques, microdissection, and confocal microscopy. The Leica DMI 6000 B is suitable for universal deployment, all contrast methods such as darkfield, brightfield, phase contrast, DIC, fluorescence, and modulation contrast are integral to the microscope and can be adapted or changed quickly and easily. Variable illumination and imaging beam paths, as well as HCS optics, modular accessories and a comprehensive range of peripherals, complement the Leica DMI 6000 B inverted research stand.

The above-named microscope complies with the Council Directive 98/79/EEC concerning in vitro diagnostics. It also conforms to the Council Directives 73/23/EEC concerning electrical apparatus and 89/336/EEC concerning electromagnetic compatibility for use in an industrial environment.



### Caution!

The manufacturer assumes no liability for damage caused by, or any risks arising from using the microscope for other purposes than those for which it is intended or not using it within the specifications of Leica Microsystems Wetzlar GmbH. In such cases the declaration of conformity shall cease to be valid.



### Caution!

This (IVD) device is not intended for use in the patient environment defined by DIN VDE 0100-710. Neither is it intended for combining with medical instruments according to EN 60601-1. If a microscope is electrically connected to a medical instrument according to EN 60601-1, the requirements defined in EN 60601-1-1 shall apply.

# 3. Safety Notes

## 3.1 General Safety Notes

This safety class 1 device is constructed and tested in accordance with  
EN 61010-2-101:2002,  
EN 61010-1:2001,  
IEC 1010-1:2001,  
Safety regulations for electrical measuring, control, and laboratory devices.



### Caution!

In order to maintain this condition and to ensure safe operation, the user must follow the instructions and warnings contained in this operating manual.



### Caution!

The devices and accessories described in this operating manual have been tested for safety and potential hazards.

The responsible Leica affiliate or the main plant in Wetzlar must be consulted whenever the device is altered, modified, or used in conjunction with non-Leica components that are outside of the scope of this manual.

Unauthorized alterations to the device or noncompliant use shall void all rights to any warranty claims!

### 3. Safety Notes

#### 3.2 Electrical Safety

##### General specifications

##### Leica CTR6000 Electronics Box

For indoor use only.

Supply voltage:	90-250V~
Frequency:	50-60 Hz
Power input:	max. 290VA
Fuses:	T6.3 A (IEC 60127-2/3)
Ambient temperature:	15-35°C
Relative humidity:	max. 80% to 30°C
Overvoltage category:	II
Pollution degree:	2

##### Microscope

For indoor use only.

Supply voltage:	90-250V~
Frequency:	50-60 Hz
Power input:	See CTR6000
Fuses:	See CTR6000
Ambient temperature:	15-35°C
Relative humidity:	max. 80% to 30°C
Overvoltage category:	II
Pollution degree:	2

##### ebq 100 Supply Unit\*

For indoor use only.

Supply voltage:	90-250V~
Frequency:	50-60 Hz
Power input:	max. 155VA
Fuses:	2xT2A (IEC 127)
Ambient temperature:	10-36°C
Relative humidity:	max. 80% to 30°C
Overvoltage category:	II
Pollution degree:	2

(See enclosed manual)



##### Caution!

Power plugs may only be plugged into an outlet equipped with a grounding contact.

Do not interfere with the grounding function by using an extension cord without a ground wire. Any interruption of the ground wire inside or outside of the device, or release of the ground wire connection, can cause the device to become hazardous. Intentional ground interruption is not permitted!



##### Caution!

Peripheral devices with their own or separate power supplies that are connected to the microscope can have the same protective conductor potential by connecting them to the ground screw on the back of the Leica CTR6000 electronics box. For connections without a ground connector, Leica Service must be consulted.



##### Caution!

Never use any fuses as replacements other than those of the types and the current ratings listed here. Using patched fuses or bridging the fuse holder is not permitted. The use of incorrect fuses may result in a fire hazard.



**Caution!**

The microscope's electrical accessory components are not protected against water. Water can cause electric shock.



**Caution!**

Protect the microscope from excessive temperature fluctuations. Such fluctuations can lead to the accumulation of condensation, which can damage the electrical and optical components.  
Ambient temperature: 15-35°C.



**Caution!**

Before exchanging the fuses or lamps, be absolutely certain to switch off the main power switch and remove the power cable.

# 4. Overview of the Leica DMI 6000 B

## 4.1 Specifications

<p><b>Contrast Methods</b></p>	<ul style="list-style-type: none"> <li>• Transmitted light (DL): BF, DF, PH, DIC, Pol</li> <li>• Incident light (IL): Fluo</li> <li>• Combination (DL/IL): Fluo/DIC, Fluo/PH</li> <li>• Intermediate pupil: IMC (integrated modulation contrast) IPH (integrated pos./neg. phase contrast)</li> </ul>
<p><b>Transmitted Light Axis</b></p>	<ul style="list-style-type: none"> <li>• Automatic Illumination Manager (aperture, field diaphragm, intensity, process switching)</li> <li>• Automatic, color-neutral intensity control</li> <li>• Manual or motorized shutter</li> <li>• Lamp housing mount for interchangeable lamp housings.</li> <li>• Automatic, electronic condenser identification</li> </ul>
<p><b>Incident Light Axis</b></p>	<ul style="list-style-type: none"> <li>• Automatic Illumination Manager (aperture, field diaphragm, intensity, process switching)</li> <li>• Automatic, color-neutral intensity control             <ul style="list-style-type: none"> <li>• Motorized shutter (switching speed &lt; 50ms)</li> </ul> </li> <li>• Lamp housing mount for up to 3 interchangeable light sources</li> <li>• Motorized 6-place filter turret</li> <li>• Fluorescence Intensity Manager (FIM) (reduction of incident illumination intensity)</li> <li>• Mechanical booster lens for central boosting of fluorescence or uniform distribution</li> <li>• Motorized Excitation Manager to monitor fluorescence emission when using double and triple filter cubes</li> <li>• Ultrafast filter wheel for 3 excitation wavelengths (switching speed &lt; 50 ms)</li> </ul>
<p><b>Tube</b></p>	<ul style="list-style-type: none"> <li>• Ergonomic with or without camera port at left</li> <li>• 2 switching positions: 100%VIS and 50%VIS / 50%CAM</li> <li>• Optional Bertrand lens</li> <li>• Eye spacing adjustment</li> <li>• Height and angle adjustment (10° - 45°)</li> </ul>

<b>Magnification Changer</b>	<ul style="list-style-type: none"> <li>• Motorized</li> <li>• 3 switching positions (choice of magnifications: 1x, 1.5x, 1.6x or 2.0x)</li> <li>• Effective for all camera ports</li> </ul> <p>or</p> <ul style="list-style-type: none"> <li>• Manual</li> <li>• 2 switching positions (choice of magnifications: 1x, 1.5x, 1.6x or 2.0x)</li> <li>• Effective on tube port</li> </ul>
<b>Objective Turret</b>	<ul style="list-style-type: none"> <li>• Motorized and coded</li> <li>• 6x for objectives with M25 thread and 45mm parfocal distance</li> <li>• For DIC: motorized/coded Wollaston prism carousel</li> <li>• Anti-vibration locking</li> </ul>
<b>Stages</b>	<p>Fixed regular stages</p> <ul style="list-style-type: none"> <li>• Ceramic-coated stage plate (248mm x 204mm)</li> <li>• Heated stage plate (from 3°C above room temperature to 60°C) (248 x 212mm)</li> <li>• Temperature-controlled stage plate (0°C to 60°C) (248mm x 212mm)</li> </ul> <p>Fixed micromanipulation stages</p> <ul style="list-style-type: none"> <li>• Ceramic-coated stage plate (248mm x 204/122mm)</li> <li>• Heated stage plate (from 3°C above room temperature to 60°C) (248mm x 204/122mm)</li> <li>• Temperature-controlled stage plate (0°C to 60°C) (248mm x 204/122mm)</li> </ul> <p>Regular manual 3-plate cross-stage</p> <ul style="list-style-type: none"> <li>• Positioning range: 83mm x 127mm</li> <li>• 20 optional inserts (standard, heating, cooling) for a variety of applications, size of inserts:160mm x 110mm (compatible with scanning stages)</li> </ul> <p>Manual micromanipulation 3-plate cross-stage</p> <ul style="list-style-type: none"> <li>• Positioning range: 40mm x 40mm</li> <li>• 3 optional inserts for a variety of applications</li> </ul> <p>Motorized micromanipulation 3-plate cross-stage</p> <ul style="list-style-type: none"> <li>• Positioning range: 40mm x 40mm</li> </ul> <p>Scanning stage IM 120 x 100 (motors on top)</p> <ul style="list-style-type: none"> <li>• 1mm, 2mm, 4mm spindle pitch (higher resolution v. higher speed)</li> <li>• 20 optional inserts (standard, heating, cooling) for a variety of applications, size of inserts:160mm x 110mm</li> </ul>

## 4. Overview of the Instrument

	<p>Scanning stage IM 120 x 100 (motors on bottom)</p> <ul style="list-style-type: none"> <li>• 1mm, 2mm, 4mm spindle pitch (higher resolution vs. higher speed)</li> <li>• 20 optional inserts (standard, heating, cooling) for a variety of applications, size of inserts: 160mm x 110mm</li> </ul>
<b>Condensers</b>	<ul style="list-style-type: none"> <li>• Motorized and coded</li> <li>• Motorized or manual aperture diaphragm</li> <li>• Contrast methods: BF, DF, PH, DIC, Pol, IMC</li> <li>• Automatic method switching</li> <li>• Condenser turret with 7 positions for contrast methods</li> <li>• 2 condenser housings (S1-S28 and S70)</li> <li>• Condenser heads: S1/1.4 oil, S1/0.9 dry, S23/0.53, S28/0.55</li> <li>• Condenser heads can be swung out</li> <li>• Condenser S70 with additional lens for low magnifications</li> <li>• All condensers suitable for magnifications from 1.25x to 100x</li> <li>• With or without motorized or manual polarizer</li> <li>• With or without motorized or coded Wollaston prism disk</li> </ul>
<b>Z focus</b>	<ul style="list-style-type: none"> <li>• Motorized and coded</li> <li>• 9mm travel (1mm below, 8mm above the stage)</li> <li>• Maximum travel speed: 5mm/s</li> <li>• 5 focus steps: 0.05 <math>\mu\text{m}</math>, 0.1 <math>\mu\text{m}</math>, 0.7 <math>\mu\text{m}</math>, 1.5 <math>\mu\text{m}</math>, 5.0 <math>\mu\text{m}</math></li> <li>• Electronic focus repositioning</li> <li>• Automatic lowering prior to objective change</li> <li>• Electronic parfocality</li> </ul>
<b>Observation Ports</b>	<ul style="list-style-type: none"> <li>• Motorized and coded</li> <li>• Left side ports (100%, 80%, or 50% transmission)</li> <li>• Left side port dichroic splitting at 680 nm</li> <li>• Right side ports (100%, 80%, or 50% transmission)</li> <li>• Bottom port</li> </ul> <p>Optional</p> <ul style="list-style-type: none"> <li>• Top port with 2 switching positions <ul style="list-style-type: none"> <li>• 100% to eyepieces</li> <li>• 50% to eyepieces/ 50% to port</li> </ul> </li> </ul>

<b>Controls</b>	<ul style="list-style-type: none"> <li>• 7 fixed control buttons for illumination and apertures</li> <li>• 7 variable function buttons behind the focus controls</li> <li>• 3 fixed control buttons for focus steps</li> <li>• 2 focus hand wheels</li> <li>• 7 buttons for fluorescence cubes and shutters</li> <li>• 4 buttons for magnification changers and ports</li> <li>• SmartMove: ergonomic controller for x, y, z and 4 additional variable function buttons</li> </ul>
<b>Electronics Box Leica CTR6000</b>	<ul style="list-style-type: none"> <li>• Separate control unit for all motorized and electronic elements of the microscope such as: <ul style="list-style-type: none"> <li>• Objective turret</li> <li>• Ffocus</li> <li>• Ports</li> <li>• Magnification changer</li> <li>• Fluorescence</li> <li>• Condenser</li> <li>• Motorized stages</li> </ul> </li> <li>With <ul style="list-style-type: none"> <li>• Power supply for 100W halogen lamp</li> <li>• Power supply for SmartMove</li> </ul> </li> </ul>
<b>Interfaces</b>	<ul style="list-style-type: none"> <li>• 2 x RS232C</li> <li>• 2 x USB</li> <li>• 4 x external/internal peripherals</li> </ul>
<b>Software Tools</b>	<ul style="list-style-type: none"> <li>• Leica Application Suite (LAS) for Windows™ 2000, XP with plug-ins For: <ul style="list-style-type: none"> <li>• Microscope and camera configuration</li> <li>• Microscope and camera control</li> <li>• Image acquisition</li> </ul> </li> </ul>

## 4. Overview of the Instrument

### 4.2 Glossary

#### The Stand

Four basic versions of the Leica DMI stand (DMI 3000 B, DMI 4000 B, DMI 5000 B, DMI 6000 B) are available which can be combined into a wide range of microscope variants.

The basic building blocks of the Leica DMI6000 B stand are:

- DMI6000 B electronic stand
- Integrated fluorescence axis with motorized filter cube changer (6 positions)
- With or without bottom port
- Lateral camera ports, 100%, 80%, or 50%
- Optional top port at the left side of the tube
- Integrated motorized tube lens changer
- Optional Bertrand lens

The individual variants and their components, differences, and applications are described in this manual. The function and performance of all microscopy techniques and required accessories of the Leica DMI6000 B will be described in detail in the section of this manual that covers the operation of the microscope.

#### Tube

The tube and tube lens create the primary image together with the objective.

The tubes are an integral part of the stand and consist of a basic body and a binocular section. The trinocular tube also features a photo/video port. A switchable mirror diverts either 100% of the light to the eyepieces or camera port, or splits it, with 50% each going to the eyepieces and camera port.

A Bertrand lens is also available as an option.

#### Eyepieces

The eyepieces create an enlarged, virtual image of the actual intermediate image created by the objective. The eyepiece serves as a magnifier in this respect.

#### Intensity Controller

The stand contains a 12V 100 W transformer for continuous regulation of the intensity via the intensity controller.

The intensity can be adjusted using the controls (1.6).

#### Focus Wheel

The focus wheel allows quick, precise focusing of the microscopic image. Focusing is realized by the vertical travel of the objective turret, with a total range of 9mm.

#### Incident Light-Fluorescence Unit

The stand features an integrated fluorescence axis and a motorized filter cube changer with 6 positions.

#### Aperture Diaphragm

The aperture diaphragm determines the resolution, depth of field, and contrast of the microscopic image. The best resolution is obtained when the apertures of the objective and the condenser are roughly the same.



#### Caution:

The aperture diaphragm in the **illumination light path** is not for setting the image brightness. This should be done only with the intensity controls or neutral filters.

### Condenser

The condenser is a lens system that gathers light and projects it onto the specimen from above. The condenser is designed for the utilization of the numerical aperture in the objective.

### Condenser Height Adjustment

The markings of the transmitted-light column indicate the height to be set for the used condenser.

### Stages and Accessories

The stage is designed to accommodate the specimens to be observed. Mechanical and motorized 3-plate cross-stages are available for the Leica DMI 6000 B.

### Motorized Objective Turret and Objectives

The motorized objective turret is designed to accommodate the objectives. The L-objectives with their long working distances especially take into consideration the correction of varying container bottom thicknesses.

All microscope objectives are usable, from 1.25:1 to 100:1 magnification. All objectives in the Leica product range with a 25mm thread and coverslip correction are compatible. For performance data on Leica objectives, please refer to the most current valid objective lists available from your Leica representative.

### Transmitted Light Illumination Unit

The transmitted light illumination unit consists of an illumination carrier and the transmitted light illumination column. The transmitted light illumination carrier does not contain a lamp housing, but a filter module for two swing-in filters and, depending on the condenser used, a field diaphragm.

### Filter

The filters are generally used to enhance the contrast of the specimen and are installed in the illumination carrier. A selection of various filters can be interchanged as required.

### Field Diaphragm

The field diaphragm is used to realize Koehler illumination.

### Lamp Housing for Transmitted Light

The lamp housings 107/2 and 107 (both for 12V 100W halogen) are available for the Leica DMI 6000 B. For their descriptions and applications, please refer to the section of this manual describing the use of the microscope.

The letter L indicates a lamp housing designed for left-handed operation.

### Lamp Housing for Incident Light

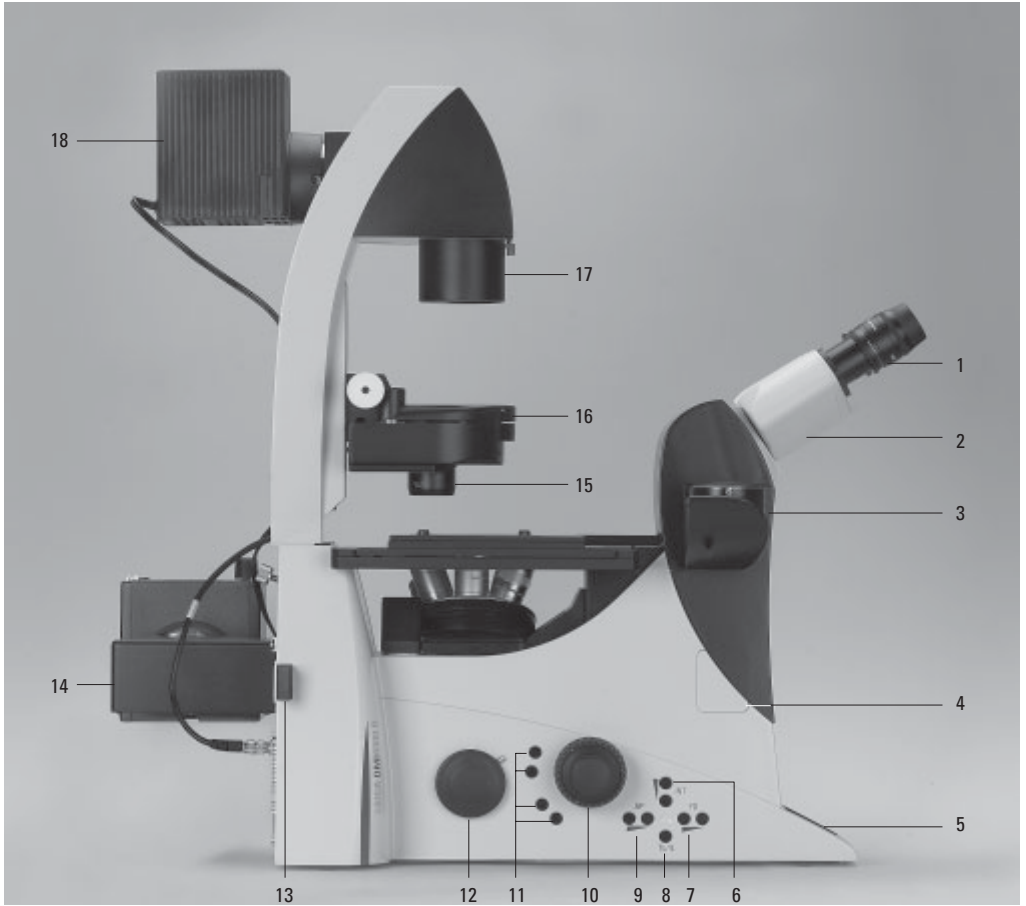
The 106 z L lamp housing (for halogen or xenon) is available for the Leica DMI 6000 B. For their descriptions and applications, please refer to the section of this manual describing the use of the microscope.

The letter L indicates a lamp housing designed for left-handed operation.

### Leica CTR6000 Electronics Box

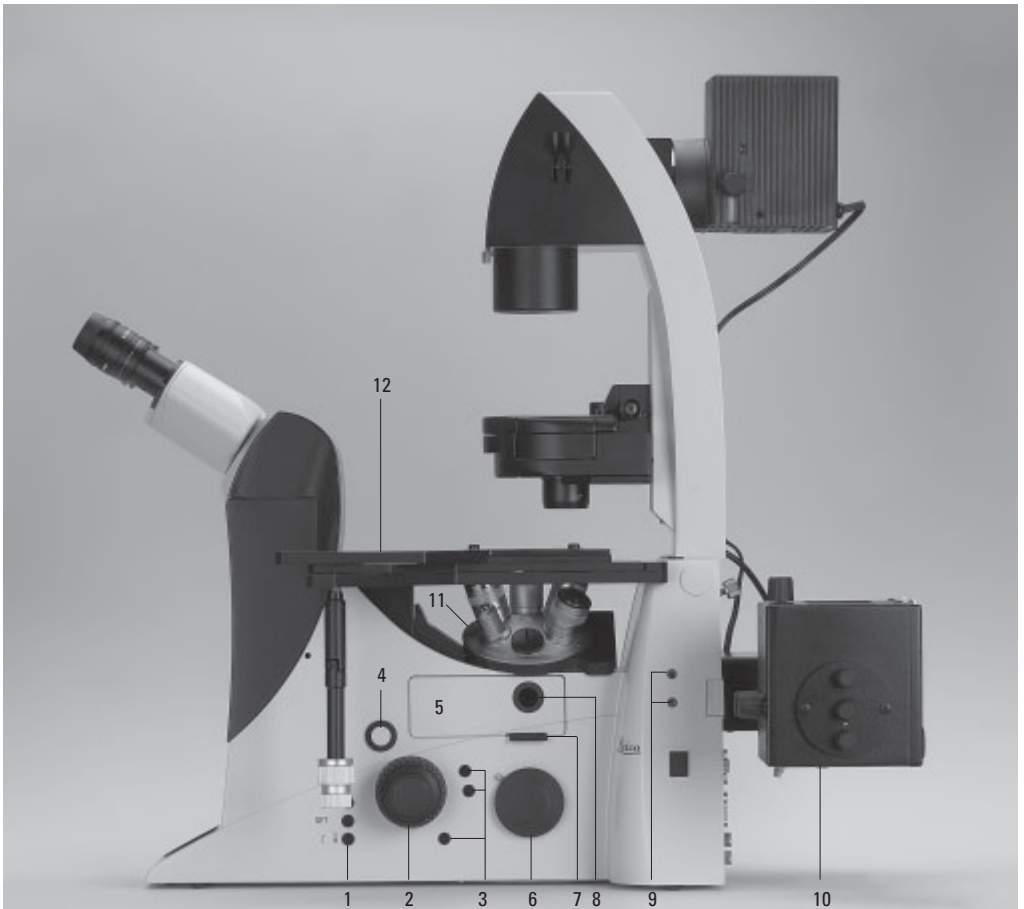
The Leica CTR6000 electronics box contains the power supply for the lamp and the circuit boards required to control the motorized functions of the stand.

## 4. Overview of the Instrument



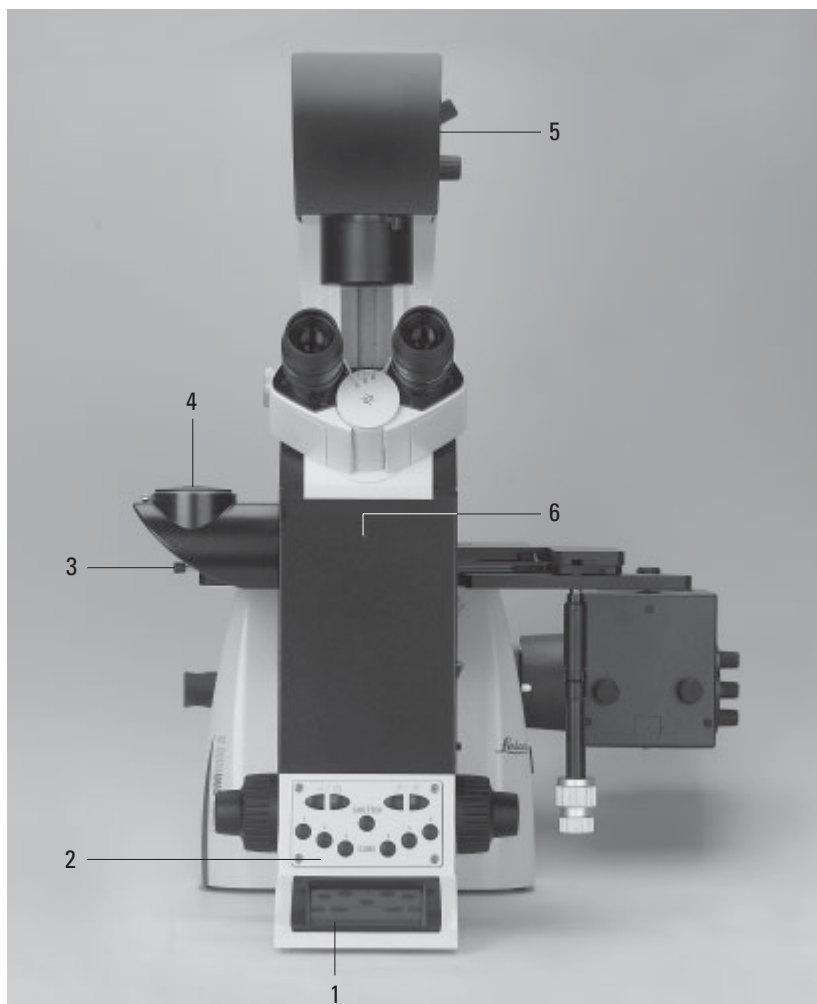
**Fig. 1** Leica DMI 6000 B left view

- |                                |                                   |
|--------------------------------|-----------------------------------|
| 1 Eyepiece                     | 11 Variable function buttons      |
| 2 Eyepiece tube                | 12 Right side port                |
| 3 Top port                     | 13 Booster lens                   |
| 4 Intermediate pupil interface | 14 Lamp mount                     |
| 5 LeicaScreen                  | 15 Condenser head                 |
| 6 Light intensity              | 16 Condenser base                 |
| 7 Field diaphragm              | 17 Field diaphragm                |
| 8 TL/IL switching              | 18 Transmitted light lamp housing |
| 9 Aperture diaphragm           | 19 DIC objective prism disk       |
| 10 Focus wheel                 |                                   |



**Fig. 2** Leica DMI 6000 B right view

- |   |                           |    |  |
|---|---------------------------|----|--|
| 1 | E-focus control buttons   | 7  | Analyzer slot                          |
| 2 | Focus wheel               | 8  | Centering window                       |
| 3 | Variable function buttons | 9  | Field diaphragm centering              |
| 4 | Opener for drawer         | 10 | Incident light lamp housing            |
| 5 | Drawer                    | 11 | Objective turret                       |
| 6 | Right side port           | 12 | Stage with attachable mechanical stage |



**Fig. 3** Leica DMI 6000 B front view

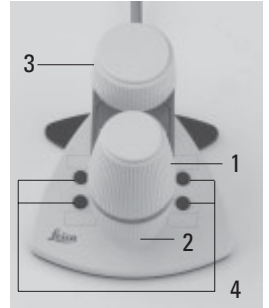
- 1 LeicaScreen
- 2 Front control panel
- 3 Port switching
- 4 Top port
- 5 Manual transmitted light filters
- 6 Field diaphragm centering

**Fig. 3a** Front control panel



**Fig. 3b** SmartMove remote control module

- 1 Travel in x
- 2 Travel in y
- 3 Focus
- 4 Variable function buttons (preassigned at factory)



**Fig. 4** Overall view of Leica DMI 6000 B with SmartMove remote control module



# 5. Unpacking the Microscope

The microscope is delivered in several packages.

The **stand package** contains the following components:

- Stand with integrated incident light axis, objective turret and tube
- Illumination arm
- Specimen stage
- CD with Leica Application Suite (LAS) software package
- Instructions and list of microscope presets (identification sheet)

The **system package** contains the microscope's accessories:

- Eyepieces
- Objectives
- Condenser
- Lamp housings with accessories
- Assembly tools
- Additional accessories such as filter cubes, etc. depending on feature set

The Leica CTR6000 electronics box, the Smart-Move remote control module and the ebq 100 supply unit are supplied in separate packages.

Please carefully compare the contents of the delivery to the packing slip, delivery note, or invoice. We urgently recommend storing a copy of these documents with the manual to ensure that you have information on the time and scope of delivery handy for subsequent orders or service work.

Please make sure that no small parts remain in the packing material. Parts of our packing material are marked by symbols to simplify recycling.

First, carefully remove all components from the transportation and packaging materials.



### Caution!

Do not put the instrument into operation in the event of visible damage to the components or packing material.



### Note:

If at all possible, avoid touching the lens surfaces of the objectives. If fingerprints do appear on the glass surfaces, remove them with a soft leather or linen cloth. Even small traces of finger perspiration can damage the surfaces in a short time. See the chapter "Care of the Microscope" → p. 95, for additional instructions.



### Caution!

Do not connect the microscope or peripherals to an AC power source at this time under any circumstances!

### Installation Location

Work with the microscope should be performed in a dust-free room, which is free of oil vapors and other chemical vapors, as well as extreme humidity. At the workplace, large temperature fluctuations, direct sunlight, and vibrations should be avoided. These may adversely affect measurements and long-term observations.

#### Allowable ambient conditions

Temperature	15-35°C
Relative humidity	maximum 80% up to 30°C

Microscopes in warm and warm-damp climatic zones require special care in order to prevent the build up of fungus.

See the chapter "Care of the Microscope" → p. 95, for additional instructions.



### Caution!

Electrical components must be placed at least 10 cm away from the wall and away from flammable substances.

## 5. Unpacking the Microscope

---

### Transport

For shipping or transporting the microscope and its accessory components, the original packaging should be used.

As a precaution to prevent damage from vibrations, the following components should be disassembled and packaged separately:

- Unscrew the objectives.
- Remove the eyepieces.
- Remove the condenser.
- Remove the specimen stage.
- Remove the transmitted light arm.
- Remove the lamp housings.
- Remove the lamp housing mount.
- Disassemble the burner of 106 z lamp housing.
- Remove the filter cube.
- Remove all moving or loose parts.

# 6. Assembling the Microscope

The microscope components are logically assembled in this order:

- Transmitted light illumination carrier
- DIC module and DIC objective prisms\*
- Specimen stage
- Condenser with condenser head
- Eyepieces
- Objectives
- Transmitted light lamps
- Lamp housing mount (mirror housings)
- Incident light lamps
- Assembly of incident light turret disk\*
- Polarizer and analyzer\*

When using intermediate systems and optical accessories, the sequence may vary.

In this case, read Chapter "6.15 Optional Accessories" → p. 52.

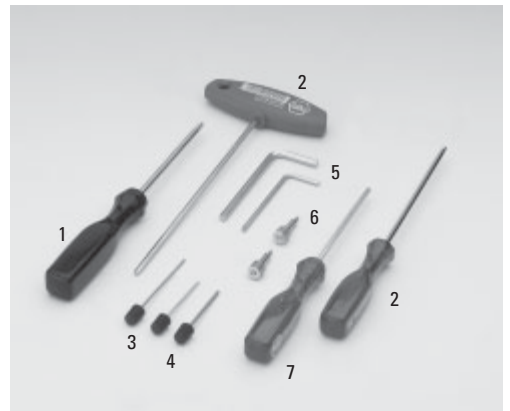
## 6.1 Assembly Tools

If possible, the microscope should be assembled and set up with the assistance of Leica sales or service personnel.

A small number of universal screwdrivers which are included in the scope of delivery are required for assembly (Fig. 7).

**Fig. 7** Assembly tools

- 1 Phillips screwdriver\*
- 2 3mm Allen key
- 3 1.5mm centering key\*
- 4 2mm centering key\*
- 5 3mm hex key\*
- 6 2.5mm hex key\* (short type)
- 7 2.5mm hex key\*



\* depending on scope of delivery

### 6.2 Installation of the Transmitted Light Illumination Carrier (DL)

Wipe the installation surface (8.3) with a dry cloth. Tip the illumination carrier (8.1) back slightly and install it so that the pin (8.2) engages the groove in the support surface (8.4).

Set the DL illumination carrier upright and fasten it with the 4 screws.

When fastening the transmitted light illumination carrier, do not hold it so as to ensure its optimal alignment with the optical axis.

The tilt angle of the illumination carrier can be varied with the knurled screw (9.1) or fixed vertically. Connect the electronics cable to one of the sockets, EXT1 - EXT4.

The transmitted light lamp housing for 12V 100W halogen lamps is a separate component. For instructions on replacing the halogen lamp → Ch. 6.10, p. 41.

### 6.3 Installation of the DIC Module and DIC Objective Prisms

If your microscope is not equipped with DIC, please continue with Chapter 6.4.

In the Leica DMI 6000 B microscope, the DIC prisms are already installed in the DIC disk below the objective turret (Fig. 10b).

Proceed as follows when making changes to the IC prism disk:

- Remove the front cover (Fig. 11) below the objective revolver after releasing the socket screws (Fig. 10a).

**Fig. 10a** Removing the front cover



**Fig. 11** Front cover, DIC prism disk



**Fig. 12** IC objective prism

- 1 Objective prism in frame
- 2 Screw and washer



- Insert the DIC prism disk (Fig. 10b) in its receptacle and tighten the two socket screws.

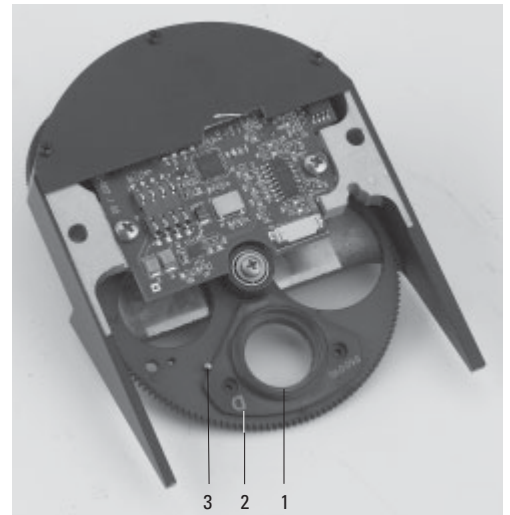
Note: insert the prism disk with the electronics board facing down.

#### Replacing Individual IC Prisms:

- Release the two socket screws and remove the prism disk.
- Place the prism against the stop pin (10b.3), place the washer between the screw and the prism, and tighten gently to prevent undue tension. Insert the prism so that its identifying letter, e.g. ID, is facing upward and is legible.
- After installing the prisms, replace the prism disk into its receptacle.

**Fig. 10b** DIC objective prism turret (coded and motorized)

- 1 IC objective prism in frame
- 2 Identification letter (ID)
- 3 Orientation pin



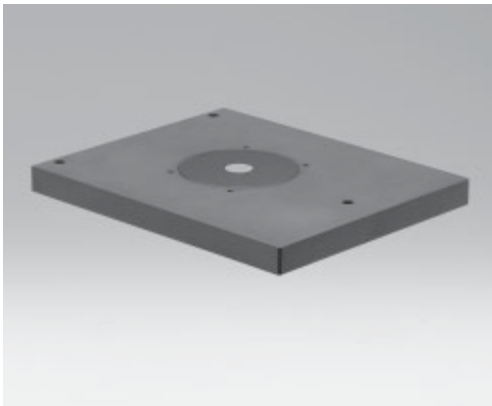
## 6. Assembly

### 6.4 Installation of Specimen Stages

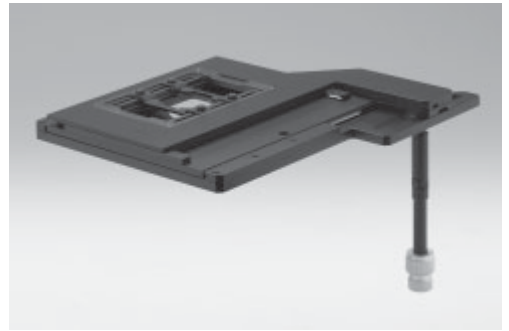
A wide range of specimen stages are available. The most important are the following:

- Fixed stage (248mm x 204mm): normal, heating and temperature-controlled
- Fixed micromanipulation stage (248mm x 204/112mm): normal, heating, temperature-controlled
- Regular manual 3-plate cross-stage, positioning range: 83mm x 127mm
- Manual micromanipulation 3-plate cross-stage positioning range: 40mm x 40mm
- Motorized micromanipulation 3-plate cross-stage positioning range: 40mm x 40mm
- Manual rotating stage
- Scanning stage IM 120 x 100 (motors on top)
- Scanning stage IM 120 x 100 (motors on bottom)

**Fig. 13** Fixed stage (normal)



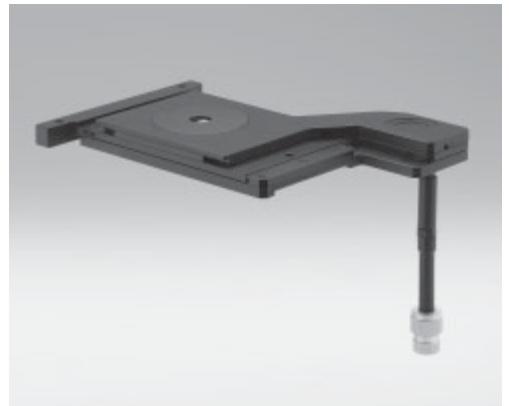
**Fig. 14** Mechanical 3-plate stage



**Fig. 15** Micromanipulation stage with attachable mechanical stage



**Fig. 16** 3-plate micromanipulation stage



The assembly of these stages is identical. The stages are solidly attached to the microscope by three screws. In the case of fixed stages, an attachable mechanical stage may be installed (Fig. 18). These are supplied in a separate package.

Multiple-plate stages are supplied separately. Like the fixed stages, these stages are mounted as follows:

- If the screws for the stage are already in the stand, remove them first. In most cases, the screws will be found in the packing material of the stand.

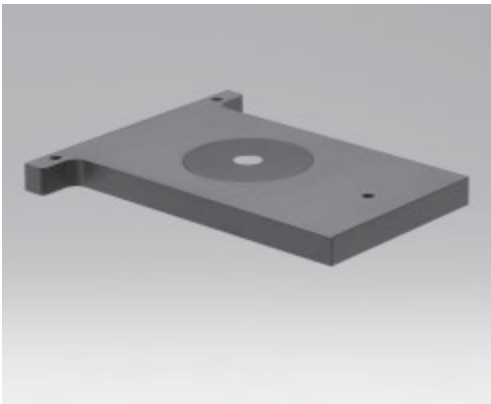


### Caution!

**The screw lengths may vary. When using screws of different lengths, use the shorter of the three screws in the front hole and the equally long ones in the rear holes.**

- Use a clean cloth to remove dust and packing material residue from the stand's contact surface with the stage.
- Align the stage so that the pair of holes faces back toward the illumination axis and the single hole faces forward toward the tube.
- Align the mounting holes in the stage with the holes in the support surface. If the holes are covered, in the case of 3-plate cross-stages or scanning stages, please shift the upper stage plate until the opening becomes visible.
- First, tighten the single front screw with the included 3mm hex screwdriver. Be sure to use the shortest of the three screws in the front hole, as an excessively long screw can interfere with the focus travel. (If you have a rotating stage, please continue reading under "Rotating Stage and Insert Frame for Cover-slips").

**Fig. 17** Fixed micromanipulation stage



**Fig. 18** Attachable mechanical stage for fixed micromanipulation stage



## 6. Assembly

- Next, firmly tighten the two rear screws.
- Finally, give the front screw a final firm tightening.

### Fixed Stage

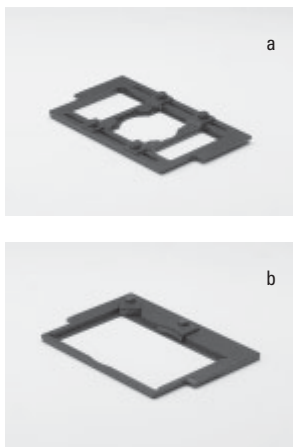
Attachable mechanical stages that are designed to accept a variety of culture dishes are also available for fixed stages. These mechanical stages may be attached to either side of the fixed stage (Fig. 17).

Two screws are located at the underside (right or left) of the attachable mechanical stage. Tighten these screws in the threaded holes on the underside of the fixed stage with the 3mm hex screwdriver. Retighten these screws from time to time after frequent use.

The attachable mechanical stage has been pre-adjusted in the factory. In the event that the attachable mechanical stage runs out of focus when moving from right to left, this can be corrected by Leica's technical service.

**Fig. 19 a, b**

Inserts for attachable mechanical stage (fixed stage)



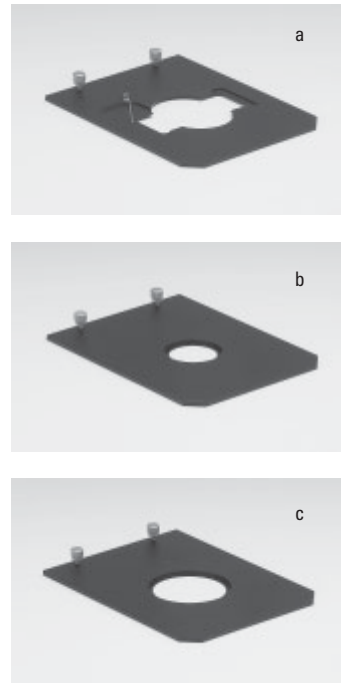
Next, remove one or more of the ordered insert frames (Fig. 20) from their packaging and place the insert frame into the precise retention system. The stage, the attachable mechanical stage, and the insert frame are now ready for use.

Some (not all) inserts are provided with self-adhesive scales to allow the coordinates to be read.

Apply these scales to the recesses of the attachable mechanical stage.

**Fig. 20 a, b, c**

Inserts for attachable mechanical stage (micromanipulation stage)

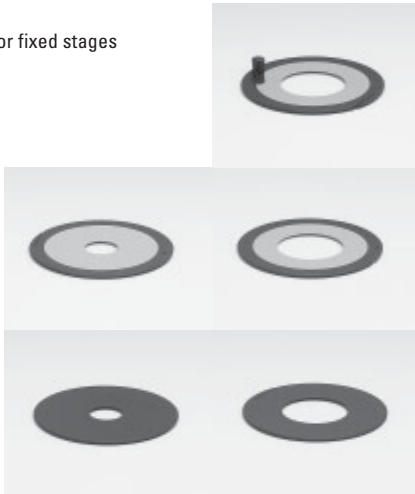


## Manual Fixed Micromanipulation Stage

To install the attachable mechanical stage for the manual fixed micromanipulation stage (Fig. 24), proceed as you would for the normal attachable mechanical stage.

The insert frames (Fig. 20a to c) differ at this point. These are held by two screws on the attachable mechanical stage and changed by releasing the screws.

**Fig. 21**  
Inserts for fixed stages



**Fig. 22**  
Glass insert for  
3-plate cross-stage  
and scanning stage



**Fig. 23**  
Heating insert P



**Fig. 24** Installation of attachable mechanical stage



**Fig. 25** Installation of attachable mechanical stage



## 6. Assembly

---

### Motorized 3-plate or Scanning Stages

**3-plate stage:** After installing the stage, connect the included stage cable to the socket on the stage, then with the CRT6000 box. The correct place on the box is called "XY Stage".

**Scanning stage:** After installing the stage, connect the included stage cable first to the X and Y sockets of the stage and the DM STC control unit for the scanning stage: XY Stage

Next, connect the DM STC control unit to the CRT6000 box. Connect the Y-cable as follows: Insert the small round plug into the **COAX CTRL** socket and the second flat plug in the **XYZ-Control** socket of the CRT6000 box. Connect the plug with the two cables to the SmartMove.

A variety of inserts (including heating ones) are available for the normal 3-plate and scanning stages. Install these inserts diagonally from above into the corner with the spring clips. The insert will click into place when installed properly.



#### Caution:

Press the spring clip into place only from the side.

Do not press the insert onto the spring clips diagonally from above, as the insert will not be aligned parallel to the stage and may be bent in the process.

### Rotating Stage and Insert Frames for Coverslips

The rotating stage (Fig. 30) is also mounted with 3 screws (30.2). Rotate the stage to make all of the threaded holes accessible. Insert the screws (30.2).



#### Caution:

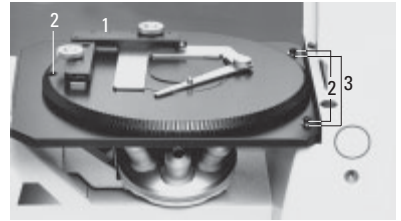
Use additional washers (30.3) for the rear holes. Tighten the screws only lightly, as the rotating stage must be centered first: Insert the adjusting aid into the rotating stage for this purpose. Activate the Bertrand lens and focus, or use a focusing telescope (Fig. 32). Move the stage until the bright circle is in the middle of the field of view. Next, tighten the stage, swing the Bertrand lens out and remove the adjusting aid.

To insert glass slides in insert frames (31.1), press on the center of the leaf spring (31.2) and insert the coverslip in the direction of the arrow.

### 6.5 Installation of Condensers

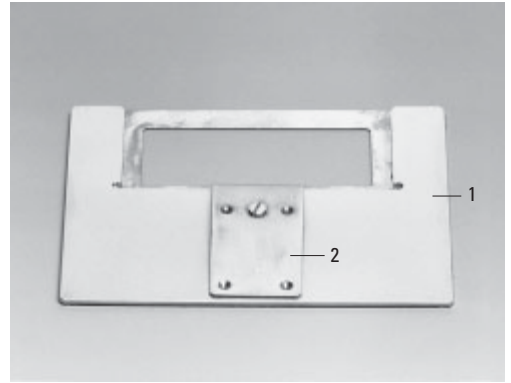
**Fig. 30** Rotating stage

- 1 Attachable mechanical stage
- 2 Screws for stage mounting
- 3 Washers

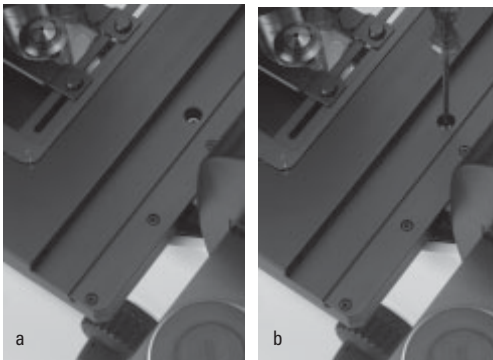


**Fig. 31**

- 1 Insert frame for coverslips
- 2 Leaf springs



**Fig. 29 a, b** Mounting screws for 3-plate cross-stage



**Fig. 32** Focusing telescope



## 6. Assembly

All the Leica DMI 6000 B microscope condensers feature 7-position turrets and can be equipped individually with suitable ring diaphragms for phase contrast (PH), darkfield (DF) or IC prisms for DL interference contrast (DIC). Light rings and condenser prisms are generally already installed in the turret at the factory, making the following assembly steps unnecessary. Please continue on → page 37, Installation of Condensers.

To change the components, proceed as follows:

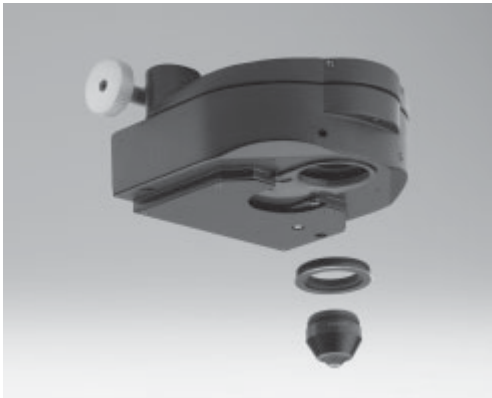
### Installing the Light Rings

Change the light rings only with the instrument's power turned off. To change the light rings, start by removing the complete condenser from the transmitted light illumination axis. Simply release the socket-head screw at the right side of the condenser mount. The condenser can now be removed very easily with Leica's own condenser quick release. Open the condenser cov-

er at the top right side. You will now have access to the various numbered openings for the light rings.

Install light rings for phase contrast (designated by the ID numbers 0, 1, 2, 3 and the focal intercept S of the corresponding condenser head) and the DF diaphragm (designated by D for darkfield and the focal intercept S of the corresponding condenser head) in the positions of the turret disk as follows:

**Fig. 33** Condenser base S1-S28



**Fig. 34**  
Condenser head S1



**Fig. 35**  
Condenser head S28



- Select a position and make sure that the two mounting screws have been released to the point that they no longer extend into the position. To adjust the screws, turn the desired light ring position into the beam path. You can now turn the screws using the two adjusting keys.
- Next, take the special condenser tool (Fig. 38).
- If possible, install the light rings 0 to 3 in ascending order. The numbering of the openings is located at the edge of the crown gear (4 large openings: 1-4; 3 small openings: 5-7).
- Grasp the light ring to be installed with the condenser tool (the lettering must face upward and be legible) so that the groove of the tool just reaches over the edge of the light ring and the upper edge of the light ring is lying flat in the holder of the tool. Press the cheeks of the tool to grasp the light ring.
- Place the light ring in the desired opening and make a note of the opening and light ring designation for the subsequent configuration of the Leica Application Suite (LAS).
- Insert the light ring at a slight angle from above so that the frame slides under the spring clip of the receptacle. Do not press the spring clip down under any circumstances. This can destroy the clip or result in an unstable position of the light ring.
- Once the light ring is properly positioned, release the tool and install the remaining light rings in the same way.
- Use the front openings to coarsely center the light rings; the screws must not extend beyond the outer edge of the disk under any circumstances.
- Perform the fine adjustment with the Bertrand lens or telescope after switching the unit on.

**Fig. 36** Phase contrast rings



**Fig. 37** Condenser prisms



## 6. Assembly

Please continue reading if you also have to install IC prisms. Otherwise, skip to the next section.

### Installation of IC prisms

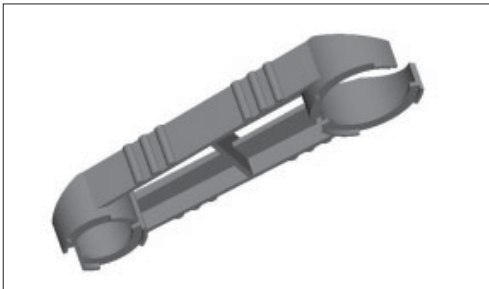
The IC prisms are installed at the factory. To change the components, proceed as follows:

Change the IC prisms only with the instrument's power turned off. To change the IC prisms, start by removing the complete condenser from the transmitted light illumination axis. Simply release the socket-head screw at the right side of the condenser mount. The condenser can now be removed very easily with Leica's own condenser quick release. Open the condenser cover at the top right side. You will now have access to the various numbered openings for the IC prisms.

- IC prisms can only be installed in the large positions of the condenser turret with guide grooves.

- Select a position and make sure that the two mounting screws have been released to the point that they no longer extend into the position. It is advisable to remove one of the screws when installing a prism, as a single screw is sufficient for centering. The opposing pressure resulting from the use of two screws may destroy the prism.
- Next, take the special condenser tool (Fig. 38).
- If possible, install the prisms 0 to 3 in ascending order. The numbering of the openings is located at the edge of the crown gear.
- Grasp the prism to be installed with the condenser tool (the lettering must face upward and be legible) so that the groove of the tool just reaches over the edge of the prism and the upper edge of the prism is lying flat in the holder of the tool. The numbers K2 to K16 should be positioned toward the end of the tool. Press the cheeks of the tool to grasp the light prism.

**Fig. 38** Condenser tool



**Fig. 39**

Inserting the condenser prisms and phase rings



- Place the prism in the desired opening and make a note of the opening and prism designation for the subsequent configuration of the Leica Application Suite (LAS).
- Insert the prism at a slight angle from above so that the frame slides under the spring clip of the receptacle. Do not press the spring clip down under any circumstances. This can destroy the clip or result in an unstable position of the prism. Two guide hooks are located on the underside of the prisms. These must fit into the two grooves of the opening. Only one of the two possible alignments is correct.
- The ID, e.g. K10, must be visible when the prism is installed and must be oriented toward the center of the condenser. The prism will also fit with the ID facing outward, but DIC imaging will not be possible in this position.
- Use the adjusting key to tighten the centering screws to the point that they no longer extend over the edge of the disk. Use only the left centering screw to position the prism (see ICT operation). The right centering screw must not restrict the range of adjustment under any circumstances.
- If necessary, carefully remove dust or fingerprints from the prisms.
- Once the prism is properly positioned, release the tool and install the remaining prisms in the same way.
- Use the front openings to coarsely center the prisms; the screws must not extend beyond the outer edge of the disk under any circumstances.
- Perform the fine adjustment with the Bertrand lens or telescope after switching the unit on.

### Installation of Condensers

The installation procedure is identical for all condensers S1 to S70 (motorized or manual/coded).

Release the socket-head screw at the right side of the condenser holder. Place the condenser on the retaining pins of the illumination arm and move the condenser to the correct height. Use the markings on the column and condenser to determine the correct position.

Once you have reached the correct position, tighten the socket-head screw.

**Fig. 40**

Installation of condenser on transmitted light illumination arm



### Condenser Heads

Four different condenser heads are available:

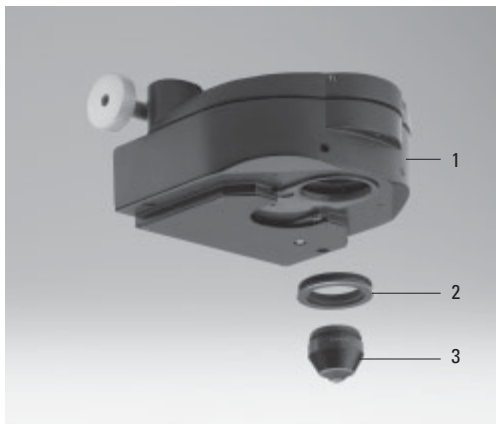
- 1) S1/1.40 oil
- 2) S1/0.90 dry
- 3) S23/0.53
- 4) S28/0.55

Condensers 3 and 4 are screwed directly into the condenser body. A spacer ring (42.2) must be screwed into the thread at the bottom of the condenser body prior to installing condensers 1 and 2. The S1 condenser heads will fit into this ring.

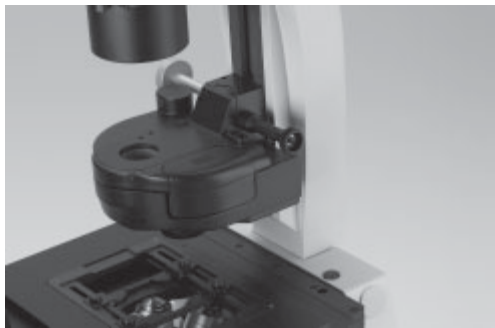
The S70 condenser is delivered complete with a condenser head, which makes additional assembly unnecessary.

**Fig. 42** Installation of condenser heads S1

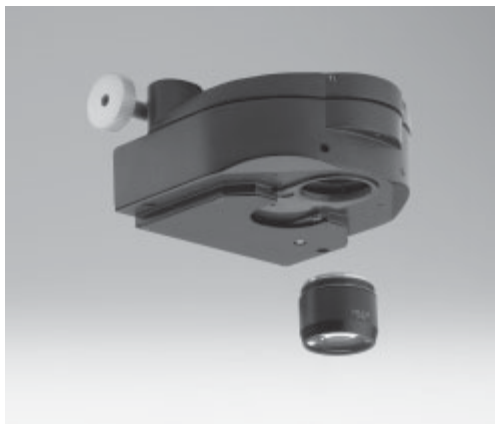
- 1 Condenser base
- 2 Spacer ring
- 3 Condenser head



**Fig. 41** Condenser on transmitted light illumination arm



**Fig. 43** Installation of condenser head S28



## 6.6 Installation of Eyepieces

The eyepieces are inserted into the eyepiece tubes.



### Note:

We recommend running a teach-in via the Leica Application Suite (LAS) software when using eyepieces not included in the scope of delivery. This will ensure that the total magnification shown in the LeicaScreen is correct.

Fig. 44 Eyepieces



Fig. 45a Objective turret



## 6.7 Installation of Objectives

The positions in the objective turret disk are numbered (Fig. 45). Depending on your equipment, the individual objectives have already been assigned to specific positions at the factory.

For details on the exact positions of the objectives, please refer to the enclosed identification sheet.



### Caution:

Close vacant threads in the nosepiece with dust protection caps!

Please note that the front lenses of the objectives point upward and are therefore more vulnerable to contamination than those of upright microscopes.

Check the front lenses for cleanliness frequently.



### Note:

We recommend running a parfocality compensation via the Leica Application Suite (LAS) software.

Fig. 45b Objective turret, loaded



## 6. Assembly

### 6.8 Installation of Filters in the Illumination Arm

The Leica DMI 6000 B is generally equipped with a holder for two 40mm diameter filters. The filters are installed at the factory. To change filters yourself, proceed as follows:

Release the screw (46.1) and remove the cover.

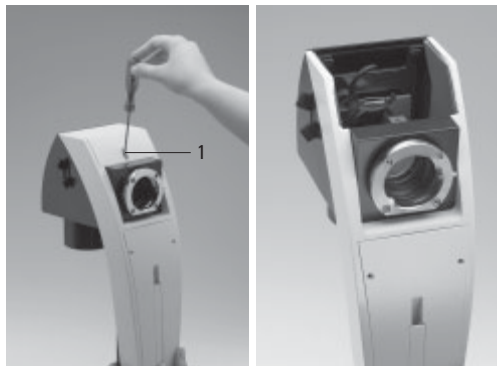
Place the filter in the holder.

Place the cover on the transmitted light illumination carrier and fasten with the locking screw.

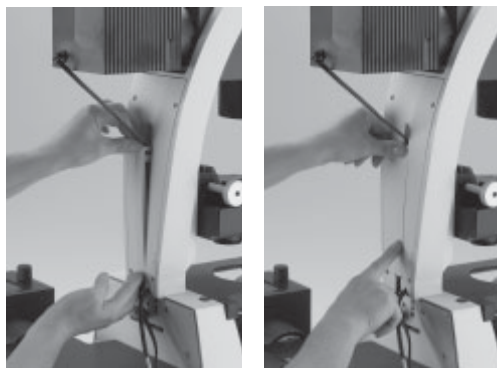
- Mark the lever with the provided adhesive labels.

**Fig. 46** Unscrewing the filter holder cover and inserting filters in the transmitted light illumination arm

1 Screw



**Fig. 48** Lamp housing cabling (cable duct)



### 6.9 Installing the Transmitted Light Lamp Housing

- Place the lamp housing in the transmitted light lamp housing mount (fig. 47) and fasten it with the clamping screw on the side.
- Thread the cable through the transmitted light illumination arm (Fig. 48).
- Connect the lamp housing cable to the power supply for transmitted light on the Leica CTR6000 electronics box (Fig. 49.1).

For instructions on changing the lamp, please see Chapter 6.10.

These instructions also apply to installing an Hg lamp on the transmitted light axis. For descriptions of the lamp housings and replacement of the burner, please see Chapter 6.12, → p. 44ff.

**Fig. 47** Mounting the lamp housing on the transmitted light illumination arm



**Fig. 49** Connecting the lamp housing to the Leica CTR6000 electronics box



## 6.10 Installation and Replacement of the Transmitted-Light Lamps: 107 or 107/2 Lamp Housing

This lamp housing is used with a 12V 100W halogen lamp, which is already mounted. In case the lamp has to be removed:

### Changing the 12V 100W Halogen Lamp



#### Caution!

Make sure that the lamp housing has been disconnected from the power supply. Unplug the power plug and the power supply during assembly.



#### Caution!

Light sources pose a potential irradiation risk (glare, UV-radiation, IR-radiation). Therefore, lamps have to be operated in closed housings.

- Remove the fastener screw on the housing (Fig. 50a).

**Fig. 50a**  
Lamp housing 107/2  
Releasing the  
fastening screw



- Lift the housing off (Fig. 50b).
- Remove the lamp.



#### Caution!

Do not remove the new lamp's dust cover until you have installed the lamp. Avoid fingerprints on the lamp.

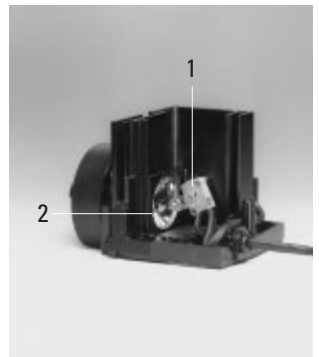
- Insert the new 12V 100W lamp (Fig. 51) with the dust cover straight into the socket until it stops. Be sure that the lamp is inserted straight.
- Remove the lamp's dust cover.
- Replace the housing and fasten it in place using the fastening screw.

**Fig. 50b**  
Removing housing



**Fig. 50c**  
Lamp housing 107/2  
opened

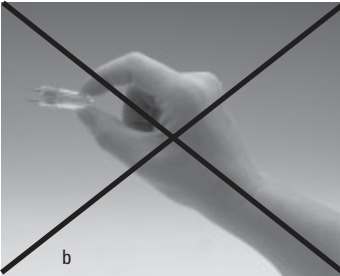
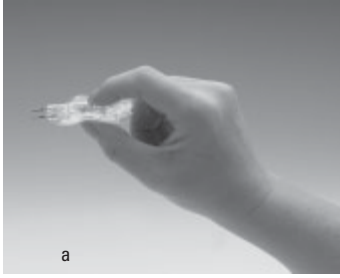
- 1 Mount with halogen lamp
- 2 Collector



## 6. Assembly

**Fig. 51**  
Inserting  
lamp with  
cover

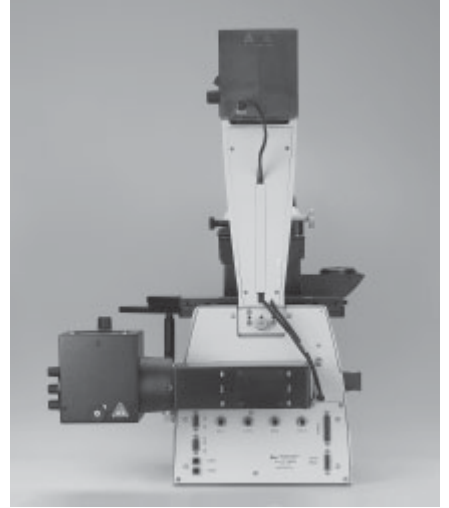
- a Right
- b Wrong



### 6.11 Installation of Lamp Housing Mount and Mirror Housing

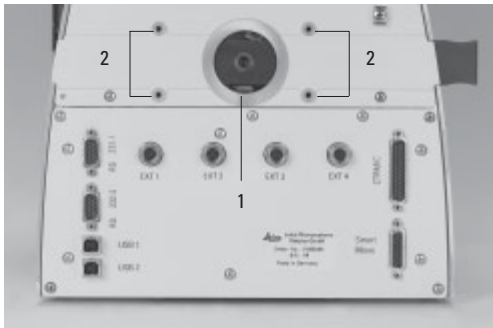
Place lamp housing mount (Fig. 53) or mirror housing on rear wall. Mount from front with socket-head screws.

**Fig. 53** Lamp housing mount



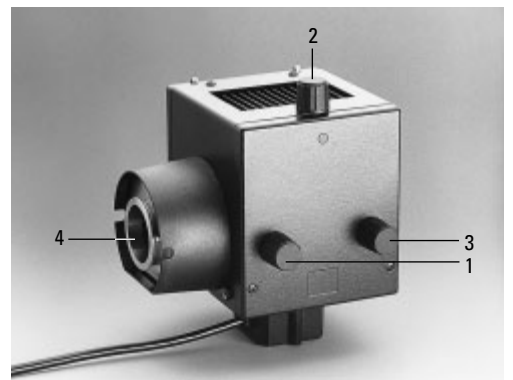
**Fig. 52** Leica DMI 6000 B rear panel

- 1 Installation point for lamp housing mount or mirror housing
- 2 Holes for lamp housing mount or mirror housing screws





**Fig. 54** Lamp housing 106z

- 1 Collector adjustment
- 2 Vertical lamp adjustment
- 3 Horizontal lamp adjustment
- 4 Adapter ring

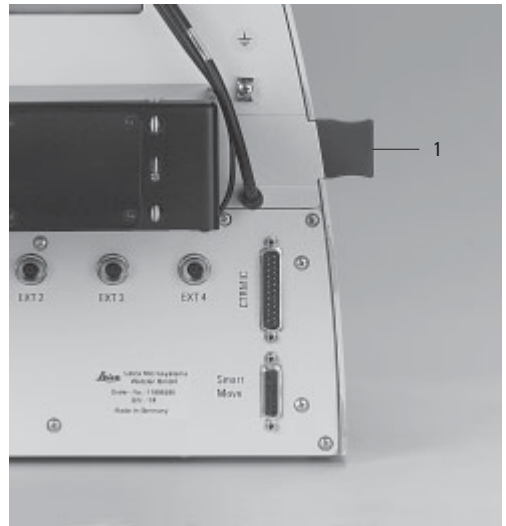


If a booster lens is included in the scope of delivery, insert it into the rear stand opening at the left or right, depending on the stand model.

The booster slide has several positions:

1. Slide pulled out:  
no effect
2. Filter position:  
wavelength of the installed filter activated
3. Depending on orientation of slide:
  - a) symbol  visible:  
center orientation  
The intensity of the fluorescence is increased by 50% in the center of the field of view (approx. 30% of the field).
  - b) symbol  visible:  
The overall intensity is reduced by 25%. The entire field of view is evenly illuminated, however.

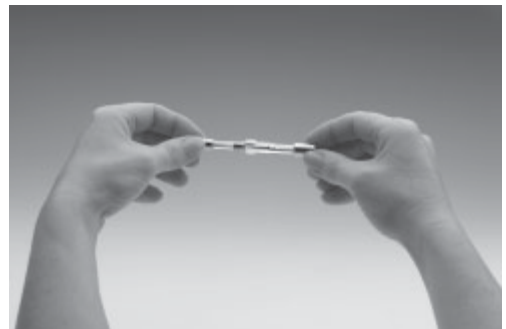
**Fig. 56** Booster lens in stand  
1 Booster lens



**Fig. 55** Booster lens



**Fig. 57** Hg-mercury burner



## 6. Assembly

### 6.12 Installation and Replacement of Incident Light Lamps



#### Caution!

Light sources pose a potential irradiation risk (glare, UV-radiation, IR-radiation). Therefore, lamps have to be operated in closed housings.

Make sure that the lamp housing has been disconnected from the power supply. Unplug the power plug and the power supply during assembly.

During assembly work on xenon burners, always wear the supplied protective gloves and face protection (Fig. 58) (risk of explosion).

Never touch the glass parts of the burner with bare hands.  
Never look directly into the beam path (blinding hazard).

**Fig. 58**  
Protective gloves and mask



### Lamp Housing 106 z

This lamp housing is suitable for use with a 12V 100W halogen lamp or a variety of gas discharge lamps.

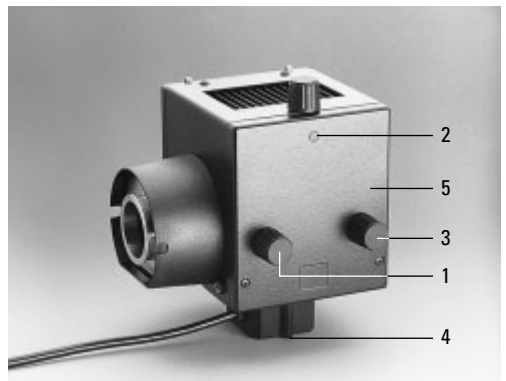


#### Caution!

Make sure to follow the instructions and safety notes of the lamp supplier.  
Before changing lamps allow at least 30 minutes for cooling down!

**Fig. 59** Lamp housing 106 z L with Hg 100W lamp

- 1 Collector focusing
- 2 Vertical lamp adjustment
- 3 Horizontal lamp adjustment
- 4 Hg lamp mount
- 5 Reflector adjustment (not visible)



## Inserting Gas Discharge Lamps (Hg and Xe) in the 106z Lamp Housing

Hg and Xe lamps are powered by separate supply units.

Please also read the separate instruction manual provided with these supply units.

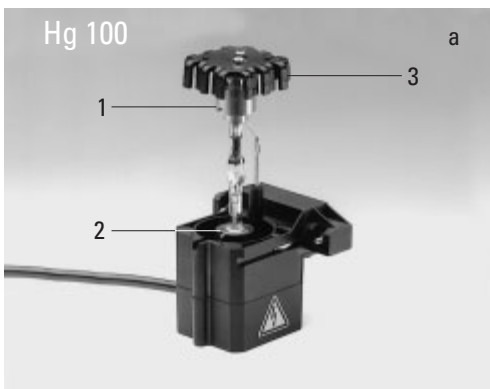
The following gas discharge lamps may be used and require different supply units and lamp mounts (Fig. 60, 61):

Type	Typical Bulb Life*
100W high-pressure mercury burner (direct current)	200 hours
100W high-pressure mercury burner (direct current, type 103 W/2)	300 hours
75W high-pressure xenon burner (direct current)	400 hours

\* Please observe the data sheets of the lamp manufacturer.

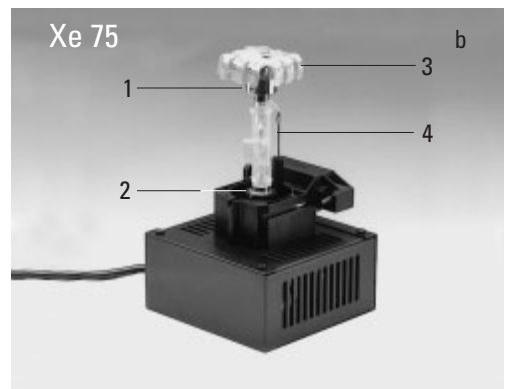
**Fig. 60** Lamp mounts for Hg 100 gas discharge lamp

- 1 Upper clamping system
- 2 Lower clamping system
- 3 Cooling element



**Fig. 61** Lamp mounts for gas discharge lamp Xe 75

- 1 Upper clamping system
- 2 Lower clamping system
- 3 Cooling element
- 4 Protective cover of Xe 75 burner



## 6. Assembly



### Caution!

**Make sure to follow the safety notes on page 44.**

- To open the 106 z lamp housing, unscrew the fastening screws (63.8) on the cover. Loosen the contact plug somewhat and pull it out of the socket (63.9). Flip the cover up (63.1).
- Loosen the mounting screws (63.8) on the lamp socket and pull the socket out.
- Remove the transport anchorage (red plastic rod in place of the burner) in the lamp mount. To do so, remove the lower clamp (60.1, 61.1). Pull up the cooling element (61.3, 60.3) and turn it to the side. Detach the lower clamp system (61.2, 60.2) and remove the transport anchorage.



### Caution!

Do not remove the burner's dust cover until you have installed the lamp. Avoid fingerprints on the lamp. Sweat from your fingers on the glass will shorten the life of the lamp significantly.

- Install the burner in reverse order.



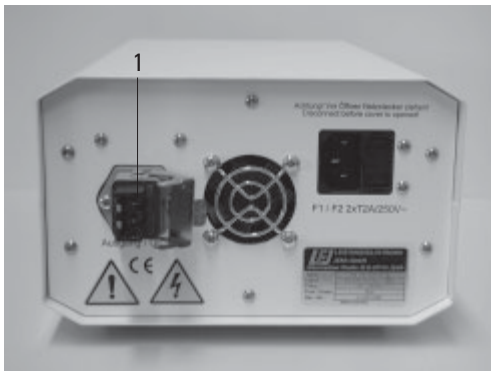
### Caution!

Xe 75 burner:

Remove the burner's dust cover (61.4) after you have installed the burner.

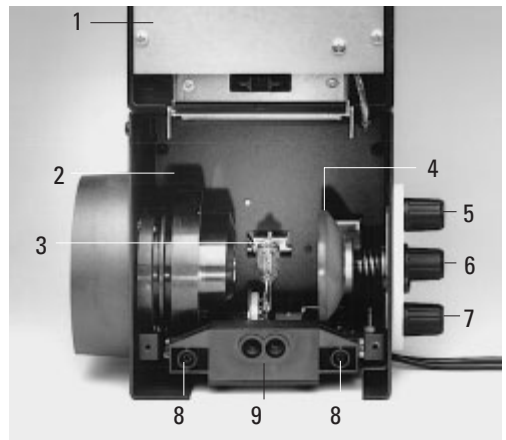
**Fig. 62** Rear panel of ebq 100 supply unit

1 Lamp connection



**Fig. 63** 106 z lamp housing (on the side, open)

- 1 Cover raised
- 2 Collector
- 3 12V 100W lamp or gas discharge lamp in mount
- 4 Reflector (mirror)
- 5, 6, 7 Adjusting screw for x-y reflector
- 8 Locking screws for lamp mount
- 9 Socket for contact plug



- Insert the lamp mount, with the burner installed, into the lamp housing and tighten it with the screws (63.8).
- Test the adjustment of the collector (63.2):  
Do not touch the power supply while performing these actions. When closing the lamp housing, make sure that the pins of the contact plug engage in their sockets (63.9). Tighten the screws of the cover and press the contact plug home.
- Place the lamp housing in the incident light lamp housing mount (fig. 53) and fasten it with the clamping screw on the side.
- Connect the lamp housing to the external power supply (62.1).



### **Caution!**

The burner must be adjusted immediately after lighting.

### 6.13 Equipping the Incident Light Turret Disk

The fluorescence drawer is located on the right side of the stand. Before opening this drawer, remove the cap below the drawer covering the analyzer slot. Remove the analyzer if it is already in the slot.

The replacement of individual cubes is more convenient with the microscope switched on. The position to be changed then automatically turns to the outside and you can be sure that the cube is positioned in the correct holder. You can therefore postpone installing the filter cubes until after the microscope has been switched on.

You can also insert the filter cubes while the instrument is switched off.

Press the white button next to the drawer. The drawer will glide out into its initial position.

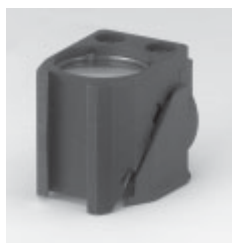
This is the only position in which the inner disk for the cubes can be turned to a free or desired position.

The positions in the turret disk are numbered. Depending on your equipment, the individual filter and reflector cubes have already been assigned to specific positions at the factory. For details, check the identification sheet included with your order.

**Fig. 64** Filter cube, front side



**Fig. 65** Filter cube, back side



**Fig. 66** Opening the fluorescence drawer



**Fig. 67** Open fluorescence drawer



**Fig. 68** Inserting or removing a filter cube



Now open the drawer several mm further until it clicks into its end position. The disk will no longer turn in this position.

You can now insert a filter block. Proceed as follows:

- With the holder facing you squarely, insert the filter or reflector cubes into the holder in accordance with the included identification sheet.
- The fluorescence cubes are suitable for both upright and inverted microscopes. When using them with inverted microscopes, insert them so that the writing is upside down along the lower edge.

To do so, place the filter or reflector cube on the **left** side and press it to the **right** into the mounting (Fig. 68).

- Make sure that the cube is correctly seated. A loose cube can be destroyed or block the disk.
- For the next cube, close the drawer to the point that the disk is once again free to turn. Once you have reached the next position, open the drawer fully once again. Continue in this way for all of the cubes.
- Once all filter and reflector cubes have been inserted, close the drawer and replace the analyzer or cap.

### Replacing cubes with the instrument switched on:

- Remove the analyzer or the cap of the analyzer slot.
- Press and hold the SET button on the right side of the stand and at the same time, press the button on the front panel for the cube you would like to insert or replace.
- The filter changer will then rotate to the correct position to insert or replace the cube when you open the drawer by pressing the white button on the right side of the stand. The following message will appear in the top line of the LeicaScreen.

Load.

To insert the cubes, proceed exactly as described above.

### 6.14 Installation of the Polarizer and Analyzer

Installed at the factory.

To change the components, proceed as follows:

**Manual condenser:** Attach the single or triple position holder to the top of the manual condenser. The holder has a guide that must be inserted in the opening next to the screw threads. The holder must be positioned so that the polarizer or filter to be used covers the opening of the condenser.

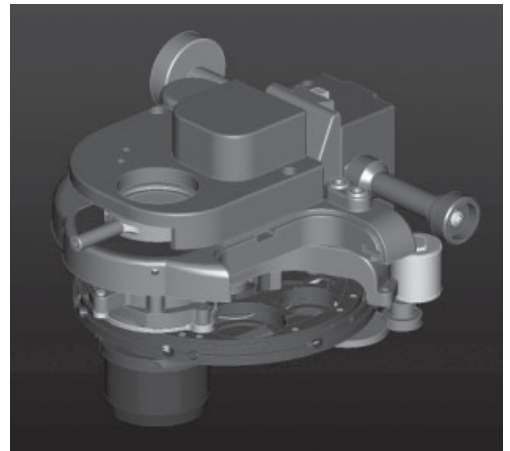
Insert the polarizer or filter with the correct side facing up into the holder ( $\lambda$ : lambda and polarizer; POL: polarizer only). A click mechanism will indicate proper seating. The polarizer must turn easily between the two stops (approx.  $30^\circ$ ).

**Fig. 70** Mechanical polarizer holder

- 1 Mechanical polarizer
- 2 Mechanical analyzer



**Fig. 71** Condenser with motorized polarizer



### Analyzer for Incident Light and Transmitted Light.

- Remove the cap (Fig. 72) on the right side of the stand (under the fluorescence drawer).
- Insert the analyzer into the receptacle until it latches in place (Fig. 73.1).

**Fig. 72** Analyzer slot cap



**Fig. 73** Inserting the analyzer

- 1 Slot
- 2 Analyzer



**Fig. 74** Inserting the analyzer



### 6.15 Optional Accessories

#### Camera

##### Connecting a camera

A camera can be installed using a C-mount or Vario mount.

- Place the C-mount or Vario mount onto one of the camera ports and secure it with the locking screw at the side.
- Screw on the camera.

Fig. 75 C-Mount 0.63x

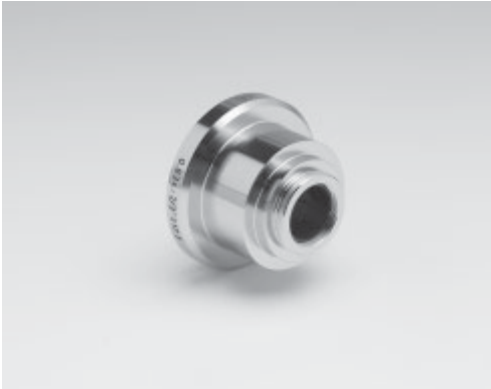


Fig. 76 C-mount 0.5x



#### **Note:**

When using a C-mount or Vario mount, run a teach-in via the Leica Application Suite (LAS) software.

##### Connecting multiple cameras

Two or more cameras – for example a digital and an analog camera – can be adapted as required.

- When using a DC type camera, connect the camera to the PCI card of your PC.
- When using a DFC type camera, connect the camera to the FireWire card of your PC.



#### **Note:**

Please read the separate operating manual of your digital camera.

### 6.16 Connection to the Electronics Box CTR6000

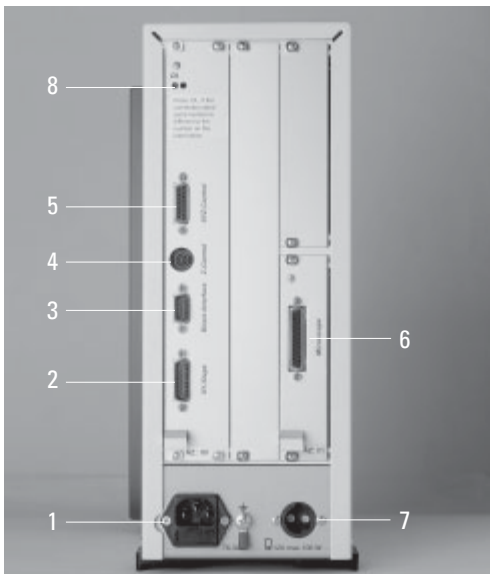
**Note:**

The CTR6000 electronics box must not be used with other stands. The serial number of the associated stand has been recorded on the back of the electronics box.

- Connect the **Microscope** (77.6) socket to the back of the stand (78.5) using the 25-pin microscope cable.
- Connect the SmartMove remote control module to the **XYZ-Control** socket (77.5).

**Fig. 77** Rear view of Leica CTR6000

- 1 AC power socket
- 2 **XY Stage** socket for motorized stage
- 3 **Direct interface** socket optional
- 4 **Z Control** for separate focus control
- 5 **XYZ Control** for SmartMove
- 6 **Microscope** socket for microscope
- 7 **12V, max 100W** for the lamp power cable of stand
- 8 DL: reset button



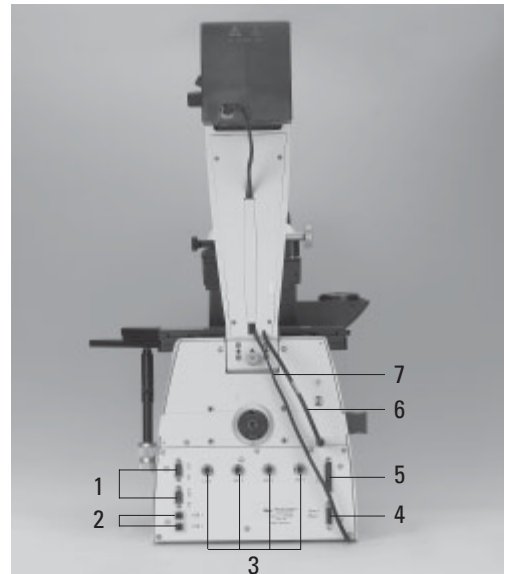
- Connect the motorized stage, if present, to the **XY-Stage** socket (77.2).
- Connect the lamp power cable (78.7) to the **12V, max 100W** socket (77.7).

**Caution!**

Make sure that the plugs are correctly inserted and secured to prevent overheating of the sockets.

**Fig. 78** Rear view of stand

- 1 RS232 ports
- 2 2 x USB
- 3 4 x EXT.
- 4 XYZ control for SmartMove
- 5 Connection for Leica CTR6000 electronics box
- 6 Condenser cable
- 7 Lamp power cable



### 6.17 Connection to the Computer



**Note:**

To start the Leica Application Suite (LAS), make sure that the COM1 serial port is not in use by another program or driver. This is frequently the case when using Palms or other PDAs or when using external modems or other devices. The devices in question must therefore **always** be disabled before using the Leica Application Suite (LAS) software.

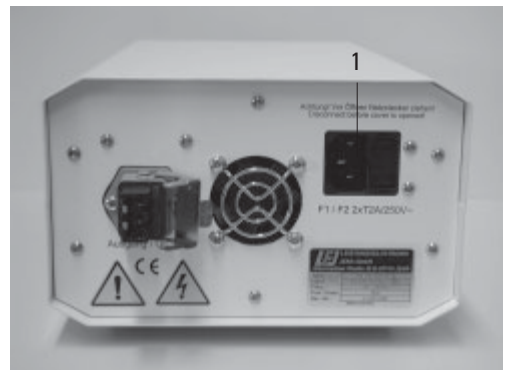
- Please use the included serial cable. Connect the COM1 port of your PC with the RS232C port (78.1) on the back of the stand.

### 6.18 Connection to the Power Supply

- Once all installation work is complete, connect the Leica CTR6000 electronics box to an AC power outlet with the included power cable (socket 77.1).
- If you are using the external ebq 100 supply unit, connect it to an AC power outlet at this time (socket 79.1).

**Fig. 79** Rear panel of ebq 100 supply unit

1 AC power socket



# 7. Start-up

## 7.1 Functional Principle

Because of its intelligent automation, the Leica DMI6000 B can be controlled using a variety of control elements.

### 1. Intelligent Automation

- Switching between contrast methods at the touch of a button. Light rings, DIC prisms, etc. are automatically positioned in the beam path.
- The microscope recognizes the selected objective and associated contrast method. The intensity (INT), aperture diaphragm (AP), and field diaphragm (FD) are always set to suitable values.
- The INT, AP, and FD values are always based on the currently activated illumination axis (transmitted light or incident light).
- The INT, AP, and FD values can be adjusted individually. Manual adjustments overwrite the previous settings. The current setting is stored and is retained from one session to the next when power is switched off.

### 2. Controls

- SmartMove knobs for stage and focus control.
- Fixed function buttons on stand for INT, AP, and FD, as well as for switching between transmitted light and incident light axis.
- Variable function buttons on stand and SmartMove  
These function buttons have functions suitable to the configuration of your microscope assigned to them at the factory. The functions can be reprogrammed and/or adapted to your specific requirements, however.
- Complete control of microscope and camera via software (Leica Application Suite (LAS))



### **Note: (Reset Function)**

The microscope can be reset to its factory default programming:

- With the stand switched off, press the top three variable function buttons on the left side of the stand.
- Switch on the power for the stand.
- Hold the buttons until the initialization is complete.
- The standard information display will now appear in the LeicaScreen (Fig. 81 and 82, p. 59).
- Switch the instrument off and back on. The settings are now saved.

The table on the following page provides an overview of the microscope functions and their controls.

Function	Fixed Function Buttons Stand	Variable Function Buttons Stand	SmartMove		Software
			Function Buttons	Rotary Knobs	
Select contrast method	-	+	+	-	+
Change transmitted light/incident light axis	+	-	-	-	+
Change to objective	-	+	+	-	+
Teach-in parfocality	-	-	-	-	+
Change operating mode (dry/imm)	-	+	+	-	+
Illumination Manager	+	+	+	-	+
Magnification Changer	+	-	-	-	+
Focusing	+	-	-	+ <sup>1)</sup>	+
Set stops	+	-	-	-	+
Go to stop	+	-	-	-	+
Change step increment (coarse/fine)	-	+	+	-	+
XY stage positioning	-	-	-	+	+
Change speed	-	-	-	-	+
Stage positions (store/go to)	-	-	--	+	
Change to filter/reflector cube	+	(+)	+	-	+
Side and bottom ports	+	(+)	+	-	+
DIC fine adjustment	+	-	-	-	+

+ always possible

(+) optional




- not possible

<sup>1)</sup> Focusing alternatively via wheels

## 7. Start-up

### Possible Assignments for Variable Function Buttons on Stand and SmartMove

For Leica DMI6000 B:

Function Button	Function
<b>BF</b>	Brightfield transmitted light
<b>PH</b>	Phase contrast transmitted light
<b>ICT</b>	Interference contrast transmitted light
<b>DF</b>	Darkfield transmitted light
<b>POL</b>	Polarization transmitted light
<b>CHANGE TL</b> 	Cycle through all contrast methods
<b>INT "</b>	Increase intensity (transmitted light)
<b>INT )</b>	Reduce intensity (transmitted light)
<b>AP "</b>	Open aperture diaphragm (transmitted light)
<b>AP )</b>	Close aperture diaphragm (transmitted light)
<b>FD "</b>	Open field diaphragm (transmitted light)
<b>FD )</b>	Close field diaphragm (transmitted light)
<b>SHUTTER TL</b>	Open/close TL shutter
<b>FLUO</b>	Fluorescence (last filter cube)
<b>CUBE 1-6</b>	Select filter cube in position 1-6
<b>CHANGE CUBE CW</b>	Change cube clockwise (1 → 4)
<b>CHANGE CUBE CCW</b>	Change cube counterclockwise (4 → 1)
<b>INT FLUO "</b>	Increase intensity (fluorescence)
<b>INT FLUO )</b>	Reduce intensity (fluorescence)
<b>FD FLUO "</b>	Open field diaphragm (fluorescence)
<b>FD FLUO )</b>	Close field diaphragm (fluorescence)
<b>CHG FW</b>	Toggle filter functions
<b>IFW</b>	Activate external filter wheel
<b>ExMan</b>	Activate Excitation Manager
<b>COMBI</b> 	Combination method (PH fluorescence or ICT fluorescence)
<b>CHANGE COMBI</b> 	Cycle through all combination methods
<b>CHANGE OBJ CW</b>	Cycle through objectives clockwise
<b>CHANGE OBJ CCW</b>	Cycle through objectives counterclockwise
<b>Z FINE</b>	Activate fine focus
<b>Z COARSE</b>	Activate coarse focus
<b>XY PRECISE</b>	Activate precise stage
<b>XY FAST</b>	Activate fast stage
<b>BTP on/off</b>	Bottom port on/off
<b>DRY/IMM</b>	Switch dry/immersion
<b>CHANGE FLT</b>	Switch TL filter
<b>CHANGE CS</b>	Switch to confocal application

## 7.2 Switching on the Microscope

- Switch on the power of the CTR6000 electronics box at the On/Off switch (80.1). The signal lamp (80.2) is lit green when the unit is ready. All motorized microscope components will then run through an initialization phase.



### Note:

If a PC is connected, switch on **the electronics box first**, and **then the computer**.

After the initialization (Fig. 81) is complete, the LeicaScreen will display the microscope's current settings (Fig. 82).

If a component has not been installed correctly, the LeicaScreen will display an error message. See Troubleshooting chapter, → p. 91.

**Fig. 80**

Front side

Leica CTR6000

- 1 On/Off switch
- 2 Signal lamp



Components such as diaphragms, condensers, light and phase contrast rings have been pre-centered at the factory. It may be necessary to correct the centering after the microscope has been transported and assembled.

Before performing the required steps, please familiarize yourself with the LeicaScreen and the controls.



### Caution!

After turning on the gas discharge lamp, the burner must be immediately adjusted. Therefore, **do not** turn on the power supply unit yet. First, work in transmitted light in order to familiarize yourself with the microscope's controls.

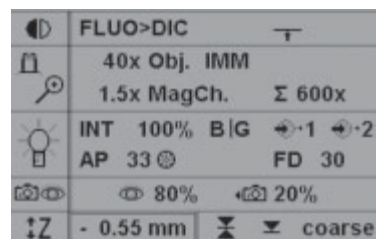
**Fig. 81**

LeicaScreen  
Initialization



**Fig. 82**

LeicaScreen  
after  
initialization



## 7. Start-up

### 7.3 The LeicaScreen

The screen displays the microscope's current settings. The content of the display depends on the features of the individual microscope.






For information on the abbreviations used, please turn to the table of abbreviations → p. 99.

The screen has a number of areas and lines.

- Line 1: Contrast method
- Line 2: Objective/magnification
- Line 3: Illumination/diaphragms
- Line 4: Active ports
- Line 5: Focus/stops

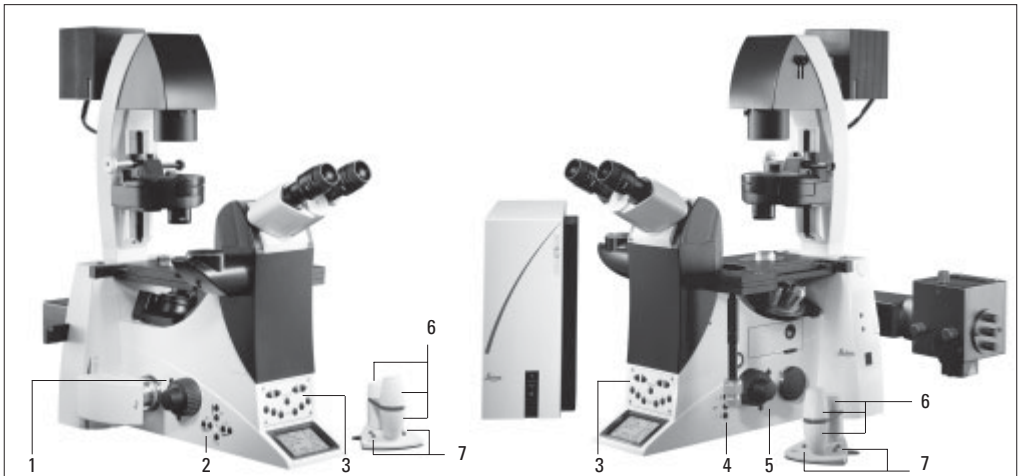
The content of the display changes according to the active function.

#### Pictograms

	Contrast Method
	Objective/ Magnification
	Illumination Diaphragm
	Ports/Eyepiece
	Focus/Stops

**Fig. 83** Arrangement of the function buttons — overview

- 1 Four variable function buttons
- 2 Illumination Manager
- 3 Front control panel
- 4 Focus control buttons
- 5 Three variable function buttons
- 6 SmartMove knobs
- 7 SmartMove function buttons



## 7.4 The Function Buttons on the Stand

A number of function buttons are located on both sides of the stand. These can be broken down into fixed and variable buttons. The variable function buttons have different functions depending on the features of the individual microscope.

### Fixed Function Buttons on the Left Side

The **TL/IL** button (84.1) toggles between the incident light and transmitted light axis. The contrast method last used with a given axis is restored when switching.

The **INT** buttons (84.3) adjust the light intensity. The adjustment can be made in coarse or fine steps. Pressing both **INT** buttons at the same time toggles between coarse and fine adjustment. "Intensity fine" will appear in the display when fine adjustment is selected.

The **AP** buttons (84.2) for the aperture diaphragm and **FD** (84.4) for the field diaphragm open and close their respective diaphragms.



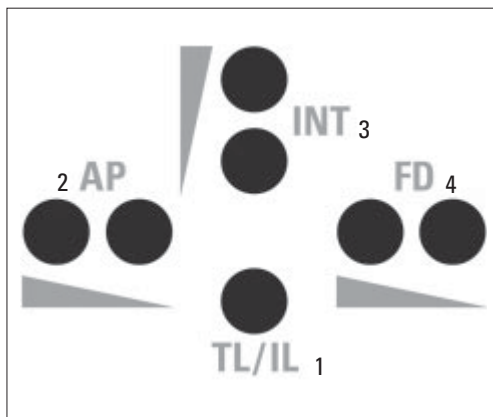
### Note:

Changes to the light intensity as well as aperture and field diaphragm settings are stored for the individual objectives and contrast methods.

### Variable Function Buttons on the Stand

#### 84 Fixed function buttons (left side of stand)

- 1 Toggle transmitted light/incident light
- 2 Aperture diaphragm
- 3 light intensity
- 4 field diaphragm



## 7. Start-up

The variable function buttons are assigned functions at the factory that are appropriate to the features of your microscope. They are labeled accordingly. For details on button assignments, please refer to the included identification sheet. For information on the abbreviations used, please refer to the list → p. 58.



### Note:

The Leica Application Suite (LAS) software is required for changing the button assignments.

### Function Buttons on the Front Panel (Fig. 87)

#### Possible Functions\*:

BF	CHANGE CUBE CW
PH	CHANGE CUBE CCW
ICT	INT FLUO "
DF	INT FLUO )
POL	FD FLUO "
CHANGE TL $\sqrt{\text{S}}$	FD FLUO )
INT "	CHG FW
INT )	IFW
AP "	ExMan
AP )	COMBI $\sqrt{\text{S}}$
FD "	CHANGE COMBI $\sqrt{\text{S}}$
FD )	CHANGE OBJ CW
SHUTTER TL	CHANGE OBJ CCW
FLUO	Z FINE
CUBE 1	Z COARSE
CUBE 2	XY PRECISE
CUBE 3	XY FAST
CUBE 4	BTP ON/OFF
CUBE 5	DRY/IMM
CUBE 6	CHANGE FLT
	CHANGE CS

\* See page 58 for abbreviations

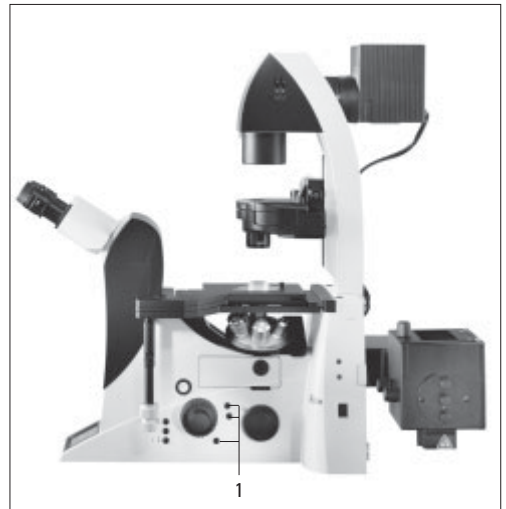
**Fig. 85** Function buttons (left side of stand)

- 1 Variable function buttons
- 2 Open/close aperture diaphragm
- 3 TL/IL switching
- 4 Open/close field diaphragm
- 5 Increase/decrease light intensity



**Fig. 86** Function buttons (left side of stand)

- 1 Variable function buttons



100% of the light goes to the eyepiece (87.1).



Toggle function for the side ports (87.2). This function depends on the individual microscope configuration.



**Note:**

Switching to the bottom port: via the variable function buttons; switching to the top port: manual.

**SHUTTER** Opens and closes the shutter (87.3).

Switches between the possible magnifications of the magnification changer (87.4).



The magnification changer is set to the magnification 1x (87.5).



**CUBE** The CUBE 1 to CUBE 6 (87.6) buttons permit the direct selection of individual filter cubes, provided the selected cube is valid for the selected method.

Press the CUBE 3 and CUBE 4 buttons at the same time to display the assignments of the variable function buttons. To reset the display, press the buttons again or wait 3 seconds.

**Focus Buttons (Fig. 88)**

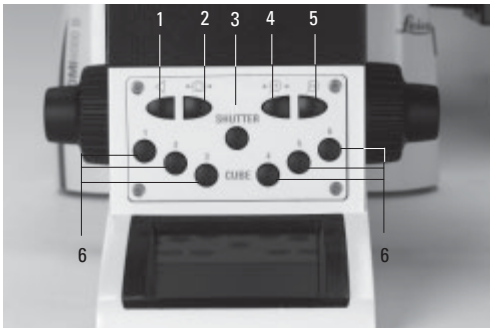
**Z"** Moves the Z drive in the indicated direction.  
**Z/**

**SET + Z"** Sets the upper focus stop.

**SET + Z/** Sets the lower stop.

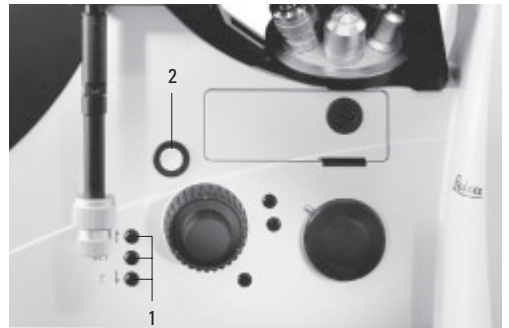
**Fig. 87** Front control panel

- 1 100% light to eyepiece
- 2 Toggle ports
- 3 Shutter
- 4 Switch magnifications
- 5 Magnification 1x
- 6 Selecting filter cubes



**Fig. 88**

- 1 Focus control buttons
- 2 Open filter drawer



## 7. Start-up

### SET + Cube Button 1-6

The selected cube is moved to the loading position for replacement. "Load" appears on the screen. Press the opening button (88.2) to open the drawer and position the appropriate cube. The filter cube will remain in this position after the drawer is closed.

### 7.5 The SmartMove Remote Control Module

#### SmartMove Knobs

Use the knobs 89.1 and 89.2 to move the stage in X and Y directions. Knob 89.3 focuses the image.

The height of the knobs can be adjusted to a comfortable working position by turning 89.4.

#### Variable Function Buttons on SmartMove

The variable function buttons are assigned functions at the factory that are appropriate to the features of your microscope. They are labeled accordingly. For details on button assignments, please refer to the included identification sheet. For information on the abbreviations used, please refer to the list → p. 58.



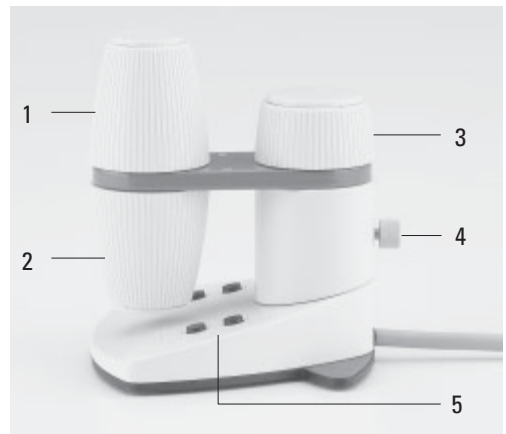
#### Note:

The Leica Application Suite (LAS) software is required for changing the button assignments.

### 7.6 Illumination

**Fig. 89** SmartMove remote control module

- 1 Travel in x
- 2 Travel in y
- 3 Focus
- 4 Individual adjustment of button height
- 5 Variable function buttons (factory preset)



### 7.6.1 Transmitted Light

If your microscope has not yet been set up for Koehler illumination, please continue with the "Koehler Illumination" section.

- Select an objective with moderate magnification (10x-20x).
- Activate the transmitted light axis with the **TL/IL** button (84.1).
- Press the **BF** button to activate the brightfield contrast method (one of the variable function buttons on the stand).
- Place a specimen on the stage.
- Focus the specimen using the SmartMove or the focus wheels.
- Adjust the light intensity with the **INT** buttons (84.3).
- Close the field diaphragm with the **FD** button (84.4) or manually until the edge of the diaphragm appears in the field of view.
- Using the condenser height adjuster (90.2), adjust the condenser until the edge of the field diaphragm appears in sharp relief.
- Open the field diaphragm just enough for it to disappear from the field of view (91d).



**Note:**

The condenser height setting is dependent on the thickness of the specimen and may require adjustment for each new specimen.

### Koehler Illumination

Suitable aperture and field diaphragm values have been preset for each objective. The condenser has also been centered at the factory. However, it may be necessary to readjust the condenser in some cases. Therefore, check the condenser centering.

The following procedure is provided for the transmitted light-brightfield illumination.

All required functions can be executed at the touch of a button with the Leica DMI 6000 B electronic microscope. (See Chapter 8, Operation).

Preparation:

- Configure the microscope as follows:  
Set up the illumination, condenser, objectives and eyepieces correctly. (Please make sure that the objectives are properly screwed in and check the eyepiece settings.)
- Switch the microscope on and wait for the initialization phase to complete (automatic functions only).
- You will need either an empty Petri dish (preferably with a glass bottom) with a marking in the middle or a stained specimen on a slide with a coverslip.
- Switch to the 10x objective (if not present, the 20x objective).

## 7. Start-up

---

- Make sure that the condenser is at the correct height. The condenser height adjustment lets you set the condenser head to the height of the nominal free working distance. (For an S23 condenser, for example, the distance between the surface of the stage and the front lens of the condenser is approx. 23mm).
- Hold a piece of white paper (approx. 3-10cm) under the light source (field diaphragm). A light ring should appear on the paper – if not, check the power cable, the light source and the fuse of the supply unit (CTR box) and make sure that all of the parts are correctly connected to one another.
- Open the field diaphragm as far as possible until the light ring reaches its maximum diameter.
- Next, hold the paper under the condenser, directly on the stage. Open the aperture diaphragm as far as possible, until the light ring has reached its maximum brightness. In order to achieve maximum brightness, make sure that no port is activated. The full light should be directed to the VIS port.
- Check the magnification changer to make sure that the 1x tube lens is selected.
- Adjust the lenses of the eyepieces so that one circle is visible in the eyepieces (not two!). If you wear eye glasses, remove the antiglare hoods from the eyepiece tubes (or fold them back).
- Make sure that the focus on the eyepieces is set to  $\pm 0$  (turn the upper part of the eyepiece tubes until the silver ring is just covered).
- You should see light when looking through the eyepieces at this point.  
If the light is too bright, reduce it as required.
- Swing all filters (in the filter magazine of the lamp housing or the filter holder of the condenser) out of the beam path.
- Set the condenser disk to the brightfield position.
- If your microscope is equipped for DIC:
  - Remove the polarizer.
  - Remove the analyzer.
  - Remove the objective prism (move the magazine to the "empty" or "brightfield" position).
- If your microscope is equipped for fluorescence:
  - Select an empty filter position (or a filter with low transmission in the visible range, e.g. filter A).

Now to begin with the actual Koehler illumination:

- Place your specimen on the stage and focus so that you can see its details as clearly as possible. You probably will not get a perfect image at this point, as the illumination will not be optimal (90a).
- Next, attempt to get a **sharp image** (or at least a part of the image at the edge) by carefully moving the condenser up and down (90.2). Try this with a variety of field diaphragm settings until you get a clear, sharp image (91.b). This may take a while!
- To **center the sharp image**, insert the centering keys in the openings provided at either side of the top part of the condenser (90.1). Move the image into the center of the field of view (91.c). Next, open the field diaphragm until the image fills nearly the entire field of view. The black edges of the image should have the same distance to the outer edge of the field of view on all sides. If

Remove all unneeded components from the light path.

not, recenter the image with the centering screws. Adjust the height of the condenser until the edges are sharp. Now open the field diaphragm until the image fills the entire field of view and the black edges have disappeared completely (91.d).

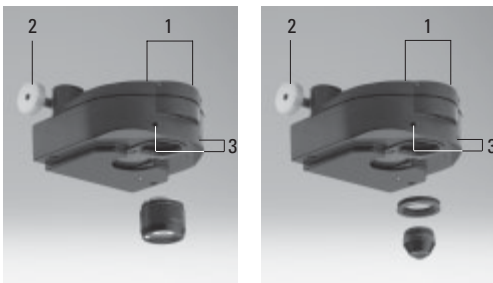
- The last step is the **adaptation of the contrast settings**. To improve the contrast, close the aperture diaphragm – if you close it too far, however, the resolution of the image details will deteriorate.

To see the aperture diaphragm, remove an eyepiece tube and look directly into the tube. Your eye should be around 10 to 20 cm from the tube. Change the size of the aperture diaphragm until its image is clearly visible in the pupil of the objective.

- Set the aperture diaphragm to cover  $2/3$  to  $4/5$  of the pupil diameter. You will now have the optimal balance between resolution and contrast.

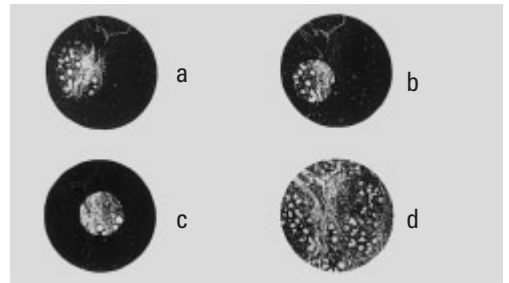
**Fig. 90** Condenser centering

- 1 Centering openings
- 2 Height adjuster
- 3 Prism and phase ring centering



**Fig. 91** Koehler Illumination

- a Field diaphragm not focused, not centered
- b Field diaphragm focused, but not centered
- c Field diaphragm focused and centered  
Diameter is too small, however
- d Illumination field diameter = visible field diameter  
(Koehler illumination)



## 7. Start-up

### 7.6.2 Incident Light - Fluorescence

Suitable aperture and field diaphragm values have been preset for each objective. The incident light module has also been centered at the factory.

However, it may be necessary to readjust the incident light module in some cases after transporting and setting up the stand. Therefore, check the field diaphragm centering.

The following procedure is provided for the incident light-brightfield illumination.

- Select an objective with moderate magnification (10x-20x).
- Activate the incident light axis with the **TL/IL** button (84.1).
- Press the **IL-BF / Fluo** button to activate the brightfield contrast method (one of the variable function buttons on the stand).
- Place a specimen on the stage.
- Focus the specimen using the SmartMove or the focus wheels.
- Adjust the light intensity with the **INT** buttons (84.3).

### Adjusting the Field Diaphragm

- Close the field diaphragm with the **FD** button (84.4) or manually until the edge of the diaphragm (round or rectangular) appears in the field of view.
- If the limits of the field diaphragm are not in the center of the field of view, move the position of the field diaphragm to the center with the two centering screws (92.1) on the right side of the stand.
- Use the function buttons **FD** (84.4) to open the field diaphragm to the point that they just disappear from the field of view.
- We recommend the use of a rectangular field diaphragm when using a digital camera. Match the size of the diaphragm to the chip size of the camera.

**Fig. 92** Adjusting the field diaphragm (incident light-fluorescence)

- 1 Adjusting screws for moving the field diaphragm



## 7.7 Checking Phase Contrast Rings

If your microscope is equipped for phase contrast, light rings to match your objectives will be installed in the condenser.

The light rings are already centered in the factory. However, the centering should be rechecked.



### Note:

Each objective has its own light ring assigned to it in the condenser. The test must therefore be performed for each objective. When selecting an objective suitable for phase contrast, the appropriate light ring will automatically be selected as well.

- Press the **BF** (brightfield) button (one of the variable function buttons on the stand).
- Instead of an eyepiece, place a focusing telescope (Fig. 93) in the observation tube or activate the Bertrand lens (pull rod (94.1) on tube).

**Fig. 93** Focusing telescope

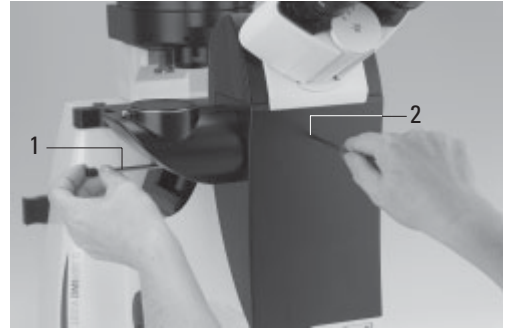
- 1 Adjustable eyelens
- 2 Clamping ring for fixing the focus position



- Select the phase contrast objective with the lowest magnification (one of the variable function buttons on the SmartMove).
- Focus on the specimen using the SmartMove or the focus wheels.

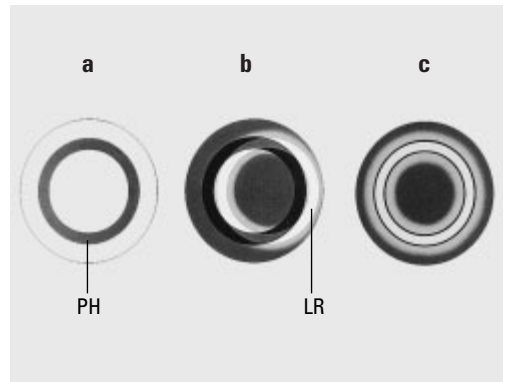
**Fig. 94**

- 1 Activating the Bertrand lens
- 2 Focusing the Bertrand lens



**Fig. 95** Phase contrast centering procedure

- PH=phase contrast ring, LR=light ring
- Condenser in brightfield (BF) position
  - Condenser in phase contrast (PH) position  
Light ring (LR) not centered
  - Light ring and phase ring centered



## 7. Start-up

- Focus the ring structure (95a) by loosening the clamping ring (93.2) somewhat and moving the eyelens (93.1), or focus the Bertrand lens (94.2).
- Retighten the clamping ring.
- Press the **PH** (phase contrast) button (one of the variable function buttons behind the focus wheels). The light ring will be selected in the condenser.
- If the light ring and the phase ring are not shown as arranged in Fig. 95c, the light ring must be centered.
- Insert the centering keys into the openings provided on both sides of the condenser (90.3).
- Turn the centering keys until the dark ring (phase ring in the objective) is congruent with the slightly narrower bright ring (light ring in condenser) (95 c).



### Caution!

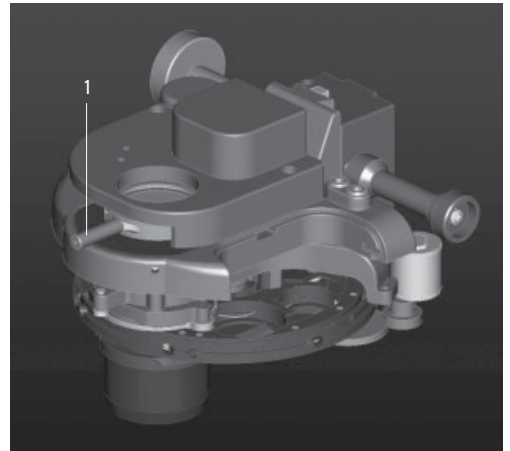
The centering keys must be removed from the centering openings before changing objectives. They may block the condenser.

- Repeat the process for all additional phase contrast objectives.
- Remove the centering keys after centering.

## 7.8 Setting the Motorized Polarizer

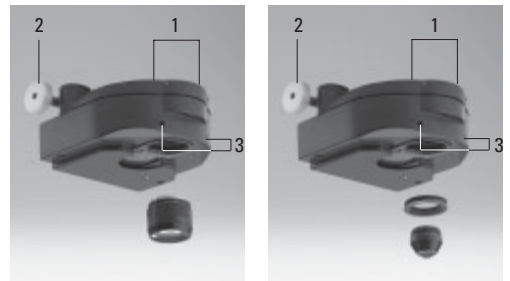
- Select the **POL method** (one of the variable function buttons on the stand).
- Insert the centering key in the opening provided on the condenser (Fig. 96).
- Set up optimal darkening. (The analyzer must be in place.)
- Remove the centering keys.

**Fig. 96** Condenser with motorized polarizer  
1 Centering key for polarizer



**Fig. 97** Condenser centering

- 1 Centering openings
- 2 Height adjuster
- 3 Prism and phase ring centering



## 7.9 Adjusting the Light Sources

### Transmitted Light Axis (TL) with Lamp Housing 107/2

The lamp housing 107/2 with a 12V 100W halogen lamp is fixed. Centering the lamp is not required.

### Lamp Housing 107 L for 12V 100W Halogen Lamp

The lamp can be adjusted using the screws (98.2) and the button (98.3).

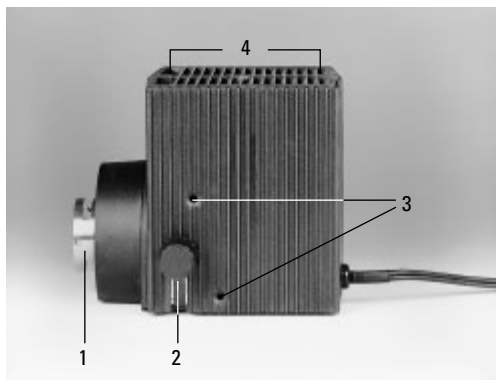
- Place a sheet of white paper under the field diaphragm.
- Adjust the lamp to create an evenly bright spot on the paper.

### Incident Light Axis (IL) with Lamp Housing 106 z

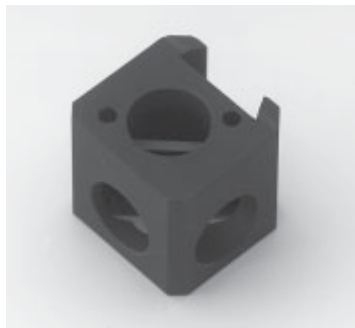
- When a supply unit is used, it is turned on first.
- Activate the incident light axis with the **TL/IL** function button. **FLUO** will appear on the LeicaScreen.
- Insert the lamp adjustment reflector (Fig. 99) in the filter turret in place of a filter cube. Make a note of the designation of the replaced filter cube.
- Turn the reflector into the beam path. The reflector is correctly positioned when the LeicaScreen shows the designation of the replaced filter cube.

**Fig. 98** Lamp housing 107 L

- 1 Locking screws for housing
- 2 Screw for vertical adjustment
- 3 Button for horizontal adjustment
- 4 Collector focusing



**Fig. 99** Reflector cube for lamp adjustment





### Caution!

Never look directly into the beam path!  
Beware of the glare hazard when switching to reflector BF or Smith!



### Caution!

Light sources pose a potential irradiation risk (glare, UV-radiation, IR-radiation).

In the lamp housing 106 z, the direct image of the filament (in halogen lamps) or the arc (in gas discharge lamps) and its reflection are focused separately and adjusted in relation to one another.

An adjustment window (2.8, p. 19) in which the light source is visible is located on the right side of the microscope.

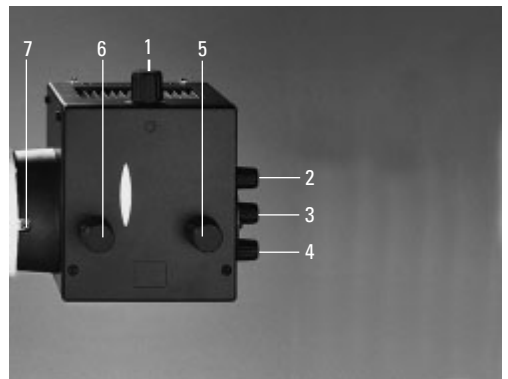
Adjust the lamp as follows while observing the light source in the adjustment window.

### Centering the Hg 100W and Xe 75 W Mercury Lamps

- The adjustment window shows the direct image of the arc and its mirror image. These are generally not in alignment with one another.
- Focus the direct image with the collector (100.6).
- Use the adjusting buttons to pivot the arc's mirror image on the rear side of the lamp housing (100.2,100.4) to the side or completely out of the beam path. The arc's focused image remains visible (Fig. 101).
- Use the adjusting buttons (100.1 and 100.5) to place the direct arc image in the middle of the centering plane, whereby the bright tip of the arc, the focal spot, should lie slightly outside the center (Fig. 102).

**Fig. 100** Lamp housing 106 z L

- 1 Lamp adjustment, vertical
- 2 Vertical reflector adjustment
- 3 Focusing the reflector image
- 4 Horizontal reflector adjustment
- 5 Lamp adjustment, horizontal
- 6 Collector focusing
- 7 Screw



- Then pivot the arc's mirror image with the adjusting knobs (100.2) and (100.4) and focus it using the reflector (100.3).
- Use the adjusting knobs (100.2) and (100.4) to orient the mirror image symmetrically to the direct image (Fig. 103).  
The V-shaped irradiation of the direct image and mirror image arcs can be superimposed.

**Caution!**

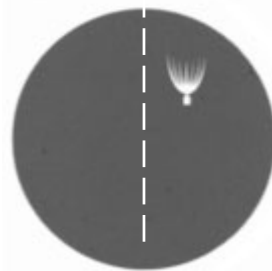
The bright tips of the arcs, the focal spots, must never be projected onto each other, as this results in a danger of explosion by overheating.

**Caution!**

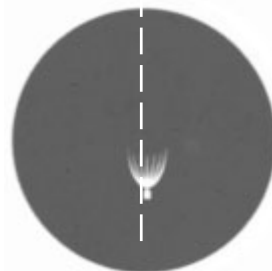
The structure of the arc can no longer be made out clearly in lamps that have been in service for a long time. The image and mirror image can no longer be superimposed exactly. In this case, align both images.

- Using the collector, defocus the image with the knob (100.6) until the arc image and mirror image are no longer recognizable and the image is homogeneously illuminated.
- Replace the lamp adjustment reflector with the original filter cube.

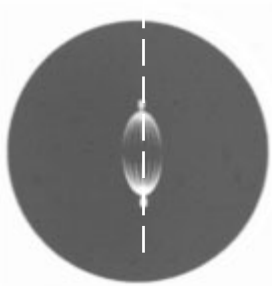
**Fig. 101** Direct arc image focused but not centered (in reality, the image is less focused)



**Fig. 102** Direct arc image in target position (in reality, the image is less focused)



**Fig. 103** Direct arc image and mirror image in target position (in reality, the image is less focused)



# 8. Operation

## 8.1 Switching On

When using a gas discharge lamp, the ebq 100 external supply unit must be turned on separately (104.1).

Switch on the power of the CTR6000 electronics box at the On/Off switch (105.1). The signal lamp (105.2) is lit green when the unit is ready.

In the case of faulty initialization ("Init Error" message on LeicaScreen), see Troubleshooting chapter, → p. 91.

All of the user's previous settings are restored during the initialization.

**!** **Caution:**

The focal position and the lower stop are also retained from one session to the next when power is switched off.



**Note:**

If a PC is connected, switch on **the electronics box first**, and **then the computer**.

All motorized microscope components will then run through an initialization phase.

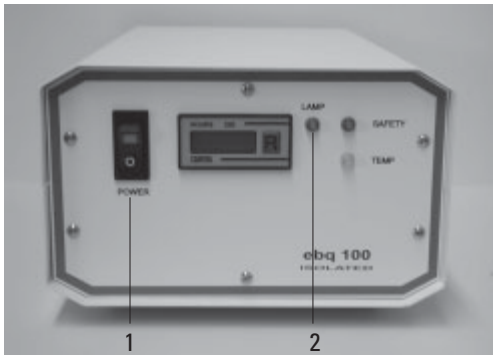
**Fig. 105**  
Front side  
Leica CTR6000  
1 On/Off switch  
2 Signal lamp



**Note:**

**Fig. 104** Front panel of ebq 100 supply unit

- 1 Power switch
- 2 Lamp status



After the initialization is complete, the LeicaScreen will display the status screen with microscope's current settings. Fig. 107 is an example.



**Note: (Reset Function)**

The microscope can be reset to its factory default programming:

- With the stand switched off, press the top three variable function buttons on the left side of the stand.
- Switch on the power for the stand.
- Hold the buttons until the initialization is complete.
- The standard information display will now appear in the LeicaScreen (Fig. 106 and 107).
- Switch the instrument off and back on. The settings are now saved.

Fig. 106 LeicaScreen initialization



Fig. 107 LeicaScreen following initialization

	FLUO>DIC	
	40x Obj. IMM	
	1.5x MagCh.	$\Sigma$ 600x
	INT 100% B G	· 1  · 2
	AP 33	FD 30
	80%	20%
	- 0.55 mm	coarse

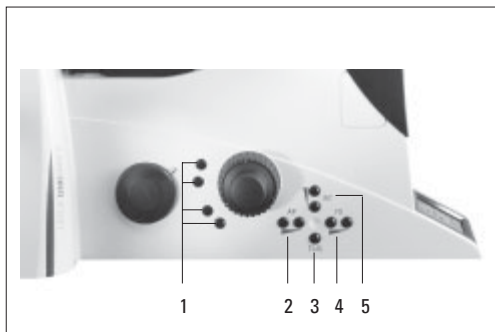
## 8. Operation

### 8.2. Contrast Methods

All contrast processes can be selected and controlled using the variable function buttons and the Leica Application Suite (LAS) software. The only exceptions to this are processes involving components that require manual operation (e.g. systems with manual analyzers). The following section describes the use of the function buttons on the stand. For instructions on the use of the software, please refer to the separate manual.

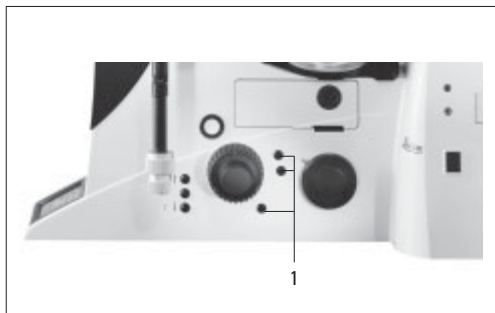
**Fig. 108** Function buttons (left side of stand)

- 1 Variable function buttons
- 2 Open/close aperture diaphragm
- 3 TL/IL switching
- 4 Open/close field diaphragm
- 5 Increase/decrease light intensity



**Fig. 109** Function buttons (left side of stand)

- 1 Variable function buttons




#### 8.2.1 Brightfield (TL)




**Note:**

If all positions of the filter turret are occupied, filter cube "A" can be swapped for filter cube "A-TL" using the Leica Application Suite (LAS). TL contrast methods are possible with that filter cube.

- Use the **TL/IL** function button to switch to transmitted light (TL).
- Select the **BF** (brightfield) contrast method by pressing the variable button **BF**.  
Alternatively: press the variable button **CHANGE TL**   
(For details on button assignments, please see the identification sheet.)  
**BF** will appear on the LeicaScreen.  
Motorized condensers will now move to the brightfield position. Coded condensers must be switched manually.  
The fluorescence filter turret will automatically go to an empty position or to the "A-TL" filter cube.
- Insert a transmitted light specimen.
- Rotate an appropriate objective into place.
- Focus the image with the knob on the SmartMove or the focusing wheel and adjust the intensity with the **INT** function buttons.

### 8.2.2 Phase Contrast (TL)


- Use the **TL/IL** function button to switch to transmitted light (TL).
- Select the **BF** (phase contrast) contrast method by pressing the variable button **PH**.  
Alternatively: press the variable button **CHANGE TL**   
(For details on button assignments, please see the identification sheet.)  
**PH** will appear on the LeicaScreen.  
Motorized condensers will now switch to the correct light ring. Coded condensers must be switched manually.
- Insert a transmitted light specimen.
- Rotate an appropriate objective into place.  
Objectives that are suitable for phase contrast are engraved with PH.
- Focus the image with the knob on the SmartMove or the focusing wheel and adjust the intensity with the **INT** function buttons.



#### Note:

When selecting the phase contrast method, the aperture diaphragm is opened fully and cannot be adjusted.

### 8.2.3 Darkfield (TL)

- Use the **TL/IL** function button to switch to transmitted light (TL).
- Select the **DF** (darkfield) contrast method by pressing the variable button **BF**.  
Alternatively: press the variable button **CHANGE TL**   
(For details on button assignments, please see the identification sheet.)  
**DF** will appear on the LeicaScreen.  
Motorized condensers will now switch to the darkfield ring. Coded condensers must be switched manually.
- Insert a transmitted light specimen.
- Rotate an appropriate objective into place.
- Focus the image with the knob on the SmartMove or the focusing wheel and adjust the intensity with the **INT** function buttons.




#### Note:

The maximum usable objective aperture for dark field is **0.70** for the condenser S1 and **0.40** for the condenser S23/S28.

When selecting the darkfield method, the aperture diaphragm is opened fully and cannot be adjusted.

## 8. Operation

### 8.2.4 Polarization (TL)

- Use the **TL/IL** function button to switch to transmitted light (TL).
- Select the **POL** (polarization) contrast method by pressing the variable button **POL**.  
Alternatively: press the variable button **CHANGE TL**   
(For details on button assignments, please see the identification sheet.)  
**POL** will appear on the LeicaScreen.

#### Manual Method:

- Move the polarizer on the condenser into the beam path.
- Insert the analyzer into the right side of the stand until it clicks into position (Fig. 110).
- Bring the polarizer and analyzer into cross position until they reach maximum darkness.
- Place a specimen on the stage and select a suitable objective.

#### Motorized Method:

- If the microscope is equipped with the relevant components, the polarizer will be activated automatically in the condenser when the **POL** contrast method is selected. The analyzer cube is also automatically positioned in the beam path.

#### Combined Methods:

- The Leica DMI6000 B microscope permits purely mechanical and motorized components — such as a mechanical analyzer and motorized polarizer — to be combined.

**Fig. 110** Inserting the analyzer



### 8.2.5 Differential Interference Contrast (TL)

- Use the **TL/IL** function button to switch to transmitted light (TL).
- Select the **DIC** contrast method by pressing the variable button **DIC**.  
Alternatively: press the variable button **CHANGE TL**  $\sqrt{\text{↔}}$   
(For details on button assignments, please see the identification sheet.)  
**DIC** will appear on the LeicaScreen.
- The polarizer in the condenser and the suitable condenser prism are automatically positioned in the beam path. The corresponding objective prism and the analyzer cube are also positioned automatically.
- Place a DIC specimen on the stage.
- Rotate an appropriate objective into place.
- Focus the image with the knob on the SmartMove or the focusing wheel and adjust the intensity with the **INT** function buttons.
- Use the knurled wheel below the objective turret for fine adjustment (Fig. 111).

Manual alternative:

- Move the polarizer on the condenser into the beam path manually.
- Insert the analyzer manually into the right side of the stand until it clicks into position (Fig. 110).  
Adjust the objective and condenser prisms manually until a valid combination appears on the display.
- Use the knurled wheel below the objective turret for fine adjustment (Fig. 111).

**Fig. 111** DIC disk with knurled wheel for fine adjustment



## 8. Operation

### 8.3 Fluorescence

- Use the **TL/IL** function button to switch to fluorescence **FLUO**.
- Place a specimen on the stage and select a suitable objective.
- The current fluorescence filter cube will be displayed on the LeicaScreen.
- You may protect your specimen from fading by closing the incident light shutter. To do so, press the **SHUTTER** button (87.3) on the front panel. The following pictogram will appear on the LeicaScreen:



#### ► Changing the Fluorescence Filter Cube

- Fixed function buttons on the front panel: **CUBE 1 to CUBE 6** or **Cube CCW**
- Variable function buttons on the front panel and SmartMove: **CUBE CW** or **CUBE CCW**
- Leica Application Suite (LAS) software

Fig. 112 Booster lens



- Focus the image with the knob on the SmartMove or the focusing wheel and adjust the intensity with the **INT** function buttons.

### Options



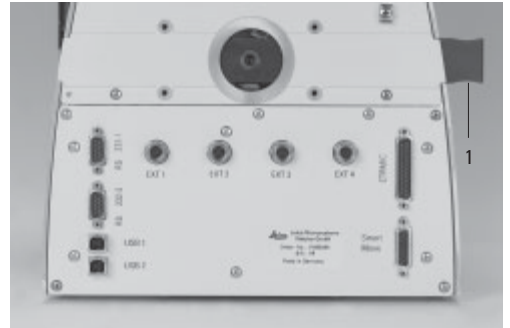
- The intensity of the fluorescence can be increased by using the booster lens (Fig. 112) on the left rear side of the stand (Fig. 113). If bright fluorescence is required in the center of the field of view, slide the booster lens into the receptacle with the marking  **1.4x** facing the user. If a homogeneous distribution over the entire field of view is required, turn the booster lens 180° so that the marking  **0.7x** is facing forward.
- For multiple fluorescence, we recommend using the Excitation Manager and/or the ultra-fast internal filter wheel. Emissions and excitation wavelengths can thus be changed in milliseconds. They are controlled by the function buttons.

Fig. 113



1 Booster lens in stand



## 8.4 Combination Methods

Up to two combination methods are possible depending on the features of the individual microscope:

FLUO/PH and FLUO/DIC

- Select the combination method by pressing the variable button **COMBI** . Alternatively: press the variable button **CHANGE COMBI** . (For details on button assignments, please see the identification sheet.) The content of the display changes accordingly.
- Place a specimen on the stage and select a suitable objective.
- Select the desired filter cube using the fixed function buttons on the front panel.
- The illumination settings for the fluorescence and transmitted light axes can be adjusted separately.
- Toggle the illumination axes with the **TL/IL** function button. The content of the LeicaScreen changes accordingly.

**FLUO > DIC**

The transmitted illumination is activated.

**FLUO < DIC**

The fluorescence illumination is activated.



### Note:

The manual analyzer (Fig. 110) must be used for the FLUO/DIC method as described in Chapter 8.2.5, p. 79.

## 8. Operation

### 8.5 Focusing



#### Note:

The parfocality teach-in has already been performed at the factory. However, it may be necessary to perform another teach-in after installing the objectives when setting the microscope up. We recommend checking parfocality before setting the stops and performing a teach-in with the Leica Application Suite (LAS) if necessary.

#### Focusing the Image

The focusing is controlled by the knobs (116.3, p. 88) on the SmartMove remote control module.

Alternatively, use the focus wheels on either side of the stand.

The current Z position is shown on the Leica-Screen. In the case of motorized stages, the Z drive will travel to its lowest position prior to the stage initialization when switching the microscope on.

The focus buttons **Z** and **Z** on the right side of the stand (Fig. 114) permit fast focusing or lowering of the objectives.

#### Setting Stops

Fig. 114

1 Focus control buttons



Set the lower focus stop by pressing and holding the **SET** button and pressing the **Z** button as well.

The display will show .

Pressing the button combination again will delete the stop.


The display will show .

The lower focus stop can also be set using the Leica Application Suite (LAS).

The **lower stop** is the same for all objectives and cannot be traversed.

In addition, a **focus position** that cannot be traversed can also be set.

To do so, press and hold the **SET** button and press the **Z** button as well.

The display will show .

Pressing the button combination again will delete the stop.

The display will show .

The focus position can also be set using the Leica Application Suite (LAS).

Set the focus position for the dry objective at the highest magnification. The focus positions will then be set automatically for all other objectives, taking parfocality and working distances into account.

#### ► Set the stops via

- Fixed function buttons on stand
- Leica Application Suite (LAS).

Summary of pictograms

Lower focus stop not set

▼ Lower focus stop set

▼ Focus position not set

⌘ Focus position set

⌘

### Going to the Stops

Go to the lower stop by pressing and holding the **Z/** button.

Go to the focus position by pressing and holding the **Z'** button.

These functions can be assigned to variable function buttons on the stand or SmartMove, or they can be controlled via software.

#### ► Go to Stops via

- Fixed function buttons on stand
- Variable function buttons on stand and SmartMove
- Leica Application Suite (LAS).



#### Note:

When going to the stops with the **Z'** and **Z/** buttons, hold the button until the stop has been reached.

### Setting the Step Increments

It is possible to toggle between **Fine** and **Coarse** step increments.

The **Fine** value varies to suit the current objective. Suitable values have been predefined. The assignments can be changed with the Leica Application Suite (LAS).

When selecting **Coarse**, the positioning speed is the same for all objectives. **Coarse** corresponds to the maximum speed.



#### Note:

The assignment of a specific step increment to an objective not only applies to the Z drive, but also to the step increments assigned to the stage when **Precise** (→ p. 88) is selected.

#### ► Switch between Fine and Coarse via

- Variable function buttons on stand and SmartMove
- Leica Application Suite (LAS).

#### 8.6 Tubes

## 8. Operation



### Note:

Close any unused tube openings, as otherwise stray light can interfere with observation.

### Adjusting the Viewing Distance


- Adjust the viewing distance of the eyepieces so that a congruent total image is seen (Fig. 115).

### Adjusting the Viewing Angle

- Ergotubes feature a tilting binocular section for a 10°-45° viewing angle adjustment range.

### Beam Splitting in Photo Tubes

The beam splitting is set manually by pulling out a control bar.

Button	Observation	Photo
VIS	100 %	0 %
50/50	50 %	50 %
BL 	activation of Bertrand lens*	

#### ► Light distribution via


- Manual control bar.

### Selecting Ports

The



button on the front control panel switches 100% of the light to the eyepieces. Use the

button, also on  front control panel, to select the side ports.

Depending on the configuration, the screen will now display

- The active port (right or left) and
- The percentage of light going to the port (100%, 80%, 50%).

Optional:

The bottom port selection function can be assigned to one of the variable function buttons on the stand or the SmartMove.

The top port can only be selected manually.

#### ► Select ports via

- Fixed function buttons on stand (side ports)
- Variable function buttons on stand and SmartMove (bottom port)
- Manual action (top port).

### 8.7 Eyepieces

Fig. 115 Tube setting



**Note:**

The eyepiece's aperture protector must be removed or folded back, during microscopy while wearing eyeglasses.

We recommend removing bifocals and spectacles with progressive-addition lenses when using the microscope.

- For the adjustable tubes with documentation output, choose the 100% VIS position.

**Eyepieces with Inlaid Reticle**

- Focus the reticle by adjusting the eyelens.
- Focus on the object through this eyepiece.
- Then, close that eye and focus on the object by adjusting only the second ocular.

**Correction for Vision Problems**

- With your right eye, look through the right eyepiece and bring the specimen into sharp focus.
- Then, with your left eye, view the same specimen and rotate the left eyepiece tube until the object is brought into sharp focus. Do not change the Z position in the process!

**Note:**

We recommend running a teach-in via the Leica Application Suite (LAS) software when using eyepieces not included in the scope of delivery. This will ensure that the total magnification shown in the LeicaScreen is correct.

**8.8 Objectives****Changing Objectives**

The objectives can be selected with the function buttons on the stand or the SmartMove, or by manually turning the objective turret. When changing objectives manually, please make sure that the turret clicks into position.

The positions of the objectives in the objective turret have been specified at the factory and must be observed when installing the objectives.

(→ also see Objectives, p. 39).

When selecting an objective, the microscope automatically selects:

- The optimal setting for the field diaphragm
- The optimal setting for the aperture diaphragm
- The light intensity for the current contrast method

The objective magnification and total magnification are displayed on the LeicaScreen.

- For **immersion objectives** use the appropriate immersion medium.

## 8. Operation

**OIL:** only use optical immersion oil according to DIN/ISO standards.

Cleaning → p. 96.

**W:** Water immersion.

**IMM:** Universal objective for water, glycerol, oil immersion.



### Caution!

Follow safety instructions for immersion oil!

#### ► Select objectives via

- Variable function buttons on stand and SmartMove
- Leica Application Suite (LAS) Software
- Manual selection

#### Changing the Operating Modes "dry" (DRY) and "immersion" (IMM)

Each objective is assigned to a specific objective category:

- 1) Dry objectives (DRY)
- 2) Immersion objectives (IMM)



### Note:

It is possible to use objectives for both operating modes.

The mode can be assigned in the Leica Application Suite (LAS).

#### Changing the Operating Mode

- First, select the operating mode (Imm or Dry) using the function buttons.  
The operating mode may also be selected in the Leica Application Suite (LAS).

- The objective turret is lowered to its bottom stop. This is to permit the application of the immersion liquid when changing from a dry to an immersion objective. It also permits the removal of the liquid when changing to dry mode.

The current objective remains in the beam path.

- Next, press the button for the objective you intend to use.



### Note:

If the **Imm** or **Dry** operating mode buttons are pressed accidentally, the original mode can be restored by pressing the appropriate button.

#### ► Change operating mode via

- Variable function buttons on stand and SmartMove
- Leica Application Suite (LAS) Software

**Note:**

When replacing objectives, you must perform a teach-in for the new objectives in the Leica Application Suite (LAS). A parfocality teach-in should also be performed.

For lockable immersion objectives lock these by pushing the front part upwards until it stops (approx. 2mm). Then, after a gentle turning motion to the right, the objective is locked.

For objectives with corrective mounts turn the knurl to adjust the objective to the thickness of the cover glass.

**8.9 Stages and Object Displacement****Object Displacement Using SmartMove****Note:****Color Coding of Objectives**

The magnification of each objective is indicated by a color ring in accordance with DIN/ISO standards:

100x 125x 150x 160x	63x	40x 50x	25x 32x	16x 20x	10x	6.3x	4x 5x	2.5x	1.6x
white	dark-blue	light-blue	dark-green	light-green	yellow	orange	red	brown	gray

Immersion objectives are marked by an additional, lower color ring.

**black** oil or Imm (universal objective for oil, water or glycerin)

**white** water

**orange** glycerin

The various engraved markings of the objectives provide information on their applications:

black or dark blue brightfield objectives, strain-free  
green phase contrast objectives, strain-free

## 8. Operation

The positioning of the stage is controlled by the knobs (116.1, 116.2) on the SmartMove remote control module.

### Setting the Step Increments

The positioning speed of the stage can be varied by switching between the **Fast** and **Precise** step increments.

When selecting **Fast**, the positioning speed is the same for all objectives.

The **Precise** speed varies to suit the current objective.

#### ► Switch between Precise and Fast via

► Variable function buttons on stand and SmartMove

► Leica Application Suite (LAS)

### Storing and Restoring Stage Positions

A variety of stage positions can be stored temporarily in the Leica Application Suite (LAS). The XY position is stored, not the Z position.

In addition to a loading position (Load), 5 stage positions can be set temporarily. When switching the microscope on, the stage will travel to a previously-defined starting position.

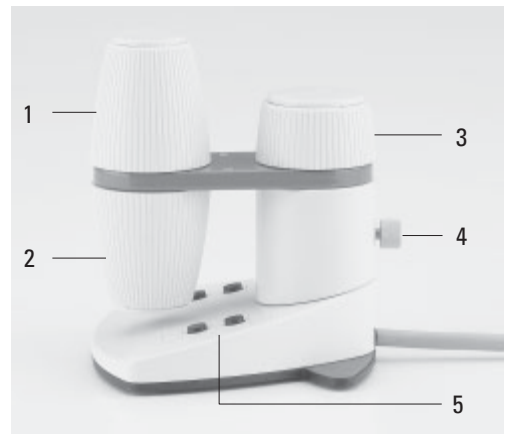
#### ► Temporarily Store and Restore Stage Positions via

► Leica Application Suite (LAS)

### 8.10 Magnification Changer

**Fig. 116** SmartMove remote control module

- 1 Travel in x
- 2 Travel in y
- 3 Focus
- 4 Individual adjustment of button height
- 5 Variable function buttons (factory preset)



A motorized magnification changer can be used optionally. The following magnification factors can be selected:

1x; 1.5x; 1,6x  
2x

The selected factor is displayed on the LeicaScreen and in the relevant field of the Leica Application Suite (LAS), and is taken into account when calculating the total magnification.

Pressing the left button (117.1) switches between the possible magnification factors; pressing the right button selects the factor 1x.

### 8.11 Light Sources

#### ► Change magnification via

- fixed function buttons on stand
- Leica Application Suite (LAS) Software

- Adjust the intensity with the function buttons (118.4). The **INT** function buttons are always assigned to the currently active transmitted light (TL) or incident light (IL) axis.

- For TL and IL:

The setting can be made in coarse and fine steps. Pressing both **INT** (118.2) buttons at the same time toggles between coarse and fine adjustment. The light intensity displayed on the LeicaScreen changes accordingly.

Coarse adjustment: 0-20

Fine adjustment: 0-255

- The intensity is individually adjusted and stored for each objective and contrast method.

- FLUO: The intensity can be adjusted in 5 fixed levels.

100% / 55% / 30% / 17% / 10%

(FIM=Fluorescence Intensity Manager)

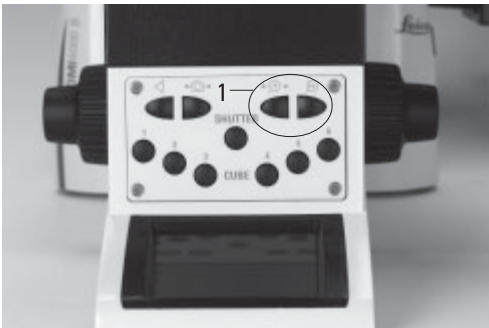
#### ► Adjust intensity via

- Fixed function buttons on stand
- Variable function buttons on stand and SmartMove
- Leica Application Suite (LAS) Software

### 8.12 Aperture and Field Diaphragm

Fig. 117 Front control panel

1 Function buttons for magnification changer



## 8. Operation

Both diaphragms have been set to suitable values for the current objective and contrast method at the factory.

- The diaphragms can be adjusted at any time with the **AP** (aperture diaphragm) (118.1) and **FD** (field diaphragm) (118.3) function buttons. The values displayed on the LeicaScreen change accordingly. The function buttons are assigned to the currently active transmitted light (TL) or incident light (IL) axis.

### ► Adjust diaphragms via

- Fixed function buttons on stand
- Variable function buttons on stand and SmartMove
- Leica Application Suite (LAS) Software



#### Caution:

The old values will be overwritten by the current ones!

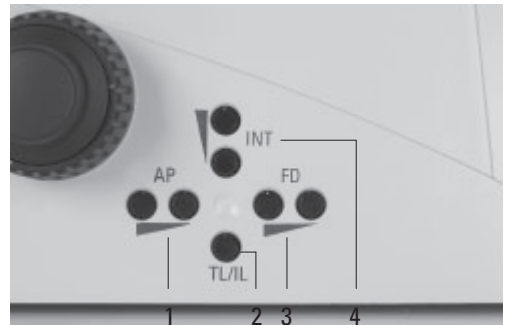


#### Caution:

When using **PH** or **DF**, the aperture diaphragm is fully open and cannot be closed.

**Fig. 118** Fixed function buttons, left side of stand

- 1 Aperture diaphragm
- 2 Transmitted light/incident light
- 3 Field diaphragm
- 4 Light intensity



# 9. Troubleshooting

Problem	Cause/Remedy
<b>Stand</b>	
The microscope does not respond.	<ul style="list-style-type: none"> <li>▶ Make sure that the AC outlet has power.</li> <li>▶ Make sure that the CTR6000 electronics box is connected to an AC outlet.</li> <li>▶ Check the cable connections.</li> <li>▶ Inform Service and have the supply unit fuse checked.</li> </ul>
<b>Illumination</b>	
The image is completely dark.	<ul style="list-style-type: none"> <li>▶ Open the shutter (→ p. 63).</li> <li>▶ Check the connections of the lamp housings on the microscope (transmitted light/fluorescence).</li> <li>▶ Make sure that the lamps are connected to the power supply and are not defective.</li> <li>▶ Inform Service and have the ebq 100 supply unit fuse checked.</li> </ul>
The image is unevenly or not uniformly illuminated.	<ul style="list-style-type: none"> <li>▶ Remove all unneeded filters from the light path.</li> <li>▶ Center the lamp (→ p. 71ff).</li> <li>▶ Replace the old lamp (→ p. 41f, 44ff).</li> </ul>
The illumination flickers.	<ul style="list-style-type: none"> <li>▶ Be sure that there is no loose connection at the power supply.</li> <li>▶ Replace the old lamp (→ p. 41f, 44ff).</li> </ul>
The lamp does not illuminate immediately upon being switched on.	<ul style="list-style-type: none"> <li>▶ The ebq 100 must be switched-on repeatedly.</li> <li>▶ Hot Hg lamps should cool down before switching on again.</li> </ul>

## 9. Troubleshooting

---

Problem	Cause/Remedy
<b>Brightfield</b>	
The specimen can not be brought into focus.	<ul style="list-style-type: none"><li>▶ Use the correct immersion medium.</li><li>▶ Place the specimen on the stage with the coverslip facing down.</li><li>▶ Make sure that the cover glass thickness is correct and that it suits the indication on the objective.</li><li>▶ Make sure that you are using an objective with coverslip correction.</li><li>▶ Adjust the correction ring on the objective if present.</li></ul>
<b>Darkfield</b>	
No definite DF contrast is possible.	<ul style="list-style-type: none"><li>▶ Be sure that a DF objective is being used.</li><li>▶ The objective aperture is too high: Maximum 0.7 for condenser S1 Maximum 0.4 for condenser S2328 If necessary, reduce the objective aperture using the iris diaphragm on the objective.</li><li>▶ Check the condenser centering.</li></ul>
The image is unevenly or not uniformly illuminated.	<ul style="list-style-type: none"><li>▶ The magnification is too weak. Use a higher magnification.</li><li>▶ Remove the condenser head or condenser lenses.</li></ul>
Undesirable stray light.	<ul style="list-style-type: none"><li>▶ Clean the specimen and neighboring lenses (→ p 95).</li></ul>

Problem	Cause/Remedy
<b>Phase contrast</b>	
No phase contrast is possible.	<ul style="list-style-type: none"> <li>▶ The specimen is too thick.</li> <li>▶ The cover glass is not placed evenly.</li> <li>▶ Check the centering of the light rings (→ p. 69).</li> </ul>
<b>Polarization</b>	
No polarization contrast is possible.	<ul style="list-style-type: none"> <li>▶ Bring the polarizer and analyzer into cross position until they reach maximum darkness (without specimen). (→ p. 78).</li> </ul>
<b>Transmitted light interference contrast</b>	
No transmitted light interference contrast is possible.	<ul style="list-style-type: none"> <li>▶ The specimen is too thick or too thin.</li> <li>▶ Embedding medium or specimen are of birefringent material. Rotate the specimen.</li> <li>▶ The difference in the refractive indices of the specimen and the embedding medium is too small.</li> <li>▶ The cover glass is too thick.</li> <li>▶ Check the Koehler illumination (→ p. 65).</li> <li>▶ Bring the polarizer and analyzer into cross position until they reach maximum darkness (without specimen). (→ p. 78).</li> <li>▶ Check whether the suitable condenser prism and corresponding objective prism are selected (manual alternative → p. 79).</li> <li>▶ Make sure that the IC prisms are correctly seated (→ p. 36).</li> </ul>

## 9. Troubleshooting

---

Problem	Cause/Remedy
<b>Fluorescence</b>	
The image is completely dark (no fluorescence).	<ul style="list-style-type: none"><li>▶ Open the shutter (→ p. 63).</li><li>▶ Select the incident light axis (IL) (→ p. 61).</li><li>▶ Check the antigen-antibody combination.</li><li>▶ Insert a new lamp (→ p. 44ff).</li></ul>
The fluorescence is too weak.	<ul style="list-style-type: none"><li>▶ Insert the booster (→ p. 80).</li><li>▶ Center the lamp (→ p. 71ff).</li><li>▶ Insert a new lamp (→ p. 44ff).</li></ul>
<b>LeicaScreen</b>	
Init Error!	<ul style="list-style-type: none"><li>▶ Check the cable connections.</li><li>▶ Check whether the cover of the filter disk has clicked into position.</li><li>▶ Check the installed objectives, filter cubes, etc.</li><li>▶ Switch the microscope off and back on.</li></ul>

# 10. Care of the Microscope



## Caution!

Unplug the power supply before performing cleaning and maintenance work!  
Protect electrical components from moisture!

Microscopes in warm and warm-damp climatic zones require special care in order to prevent fungus contamination.

The microscope should be cleaned after each use, and the microscope optics should be kept strictly clean.

## 10.1 Dust Cover



## Note:

To protect against dust, cover the microscope and accessories with the dust cover after each use.



## Caution!

Let lamps cool down before covering the stand with a dust cover. The dust cover is not heat-resistant. In addition condensation water may occur.

## 10.2 Cleaning



## Caution:

Residual fiber and dust can create unwanted background fluorescence.

## Cleaning Coated Parts

Dust and loose dirt particles can be removed with a soft brush or lint-free cotton cloth.

Stubborn dirt can be removed with all commonly available aqueous solutions, naphtha or alcohol. For cleaning coated parts, use a linen or leather cloth that is moistened with one of these substances.



## Caution:

Acetone, xylene or nitro-containing thinner can harm the microscope and thus must not be used.

Test cleaning solutions of unknown composition first on a less visible area of the unit. Be sure that coated or plastic surfaces do not become matted or etched.

## Cleaning the Stage

Rub the stage with paraffin oil or acid-free Vaseline to remove light spots on the stage.

## 10. Care of the Microscope

---

### Cleaning Glass Surfaces

Remove dust on glass surfaces with a fine, dry, and fat-free hair brush, by blowing with a blow bag or vacuum suction.

Remove stubborn dirt on glass surfaces with a clean cloth dampened with distilled water. If the dirt still can not be removed, use pure alcohol, chloroform or benzene.

### Cleaning Objectives



#### Caution!

The objective may not be unscrewed during cleaning. If damage appears on inner surfaces, the objectives must be sent to your Leica subsidiary for repair. We also advise against cleaning the inside surfaces of the eyepieces.

The front lenses of objectives are cleaned as described under "Cleaning Glass Surfaces". The upper lens is cleaned by being blown off with a pneumatic pump.

### Removing Immersion Oil



#### Caution!

Follow safety instructions for immersion oil!

First, wipe off the immersion oil with a clean cotton cloth, and then re-wipe the surface several times with ethyl alcohol.

### 10.3 Handling Acids and Bases

For examinations using acids or other aggressive chemicals, particular caution must be taken.



#### Caution:

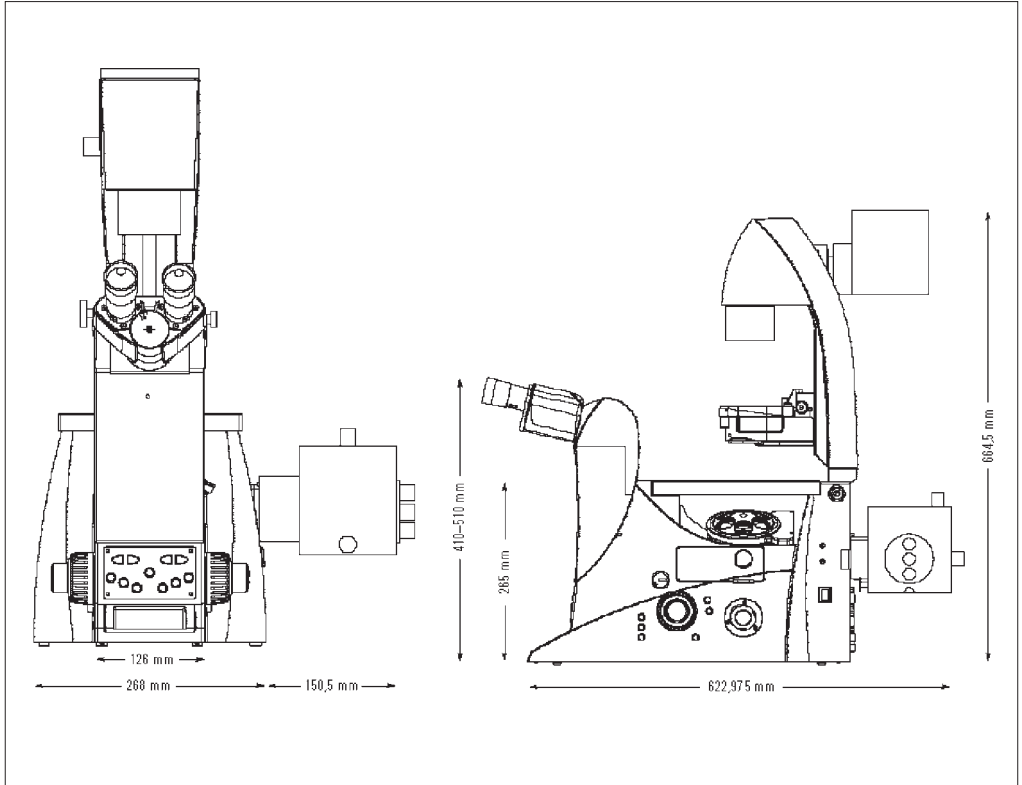
Be absolutely certain to prevent the optics and mechanical parts from coming into contact with these chemicals.

# 11. Major Consumable and Replacement Parts

Order No. Material No.	Name		Used for
<u>Replacement Lamp</u>			
11 500 974	Halogen lamp	12V 100W	107/2 lamp housing
11 500 137	High-pressure mercury burner	50 W	106 z lamp housing
11 500 138	High-pressure mercury burner	100W	106 z lamp housing
11 500 321	High-pressure mercury burner	100W (103 W/2)	106 z lamp housing
11 500 139	High-pressure xenon burner	75 W	106 z lamp housing
<u>Screw cap for unused objective receptacles</u>			
020-422-570-000	Screw cap M 25		Objective turret
<u>Cover for unused objective DIC disk opening</u>			
11 090-144-020-088	Cover for DIC		microscope stand
<u>Dust and light protection cover for analyzer slot</u>			
11 020-437-101-013	Analyzer slot cover		microscope stand
<u>Dust and light protection cover for camera port openings</u>			
11 020-387-556-009	Analyzer slot cover		microscope stand
<u>Replacement eyecup (diaphragm protection) for HC PLAN eyepiece</u>			
021-500-017-005	HC PLAN eyecup		10x/25 eyepiece
021-264-520-018	HC PLAN eyecup		10x/22 eyepiece
021-264-520-018	HC PLAN eyecup		10x/20 eyepiece
<u>Immersion oil conforming to DIN/ISO standards, fluorescence-free</u>			
11 513 787	10 ml		OIL and IMM objectives and oil condenser heads
11 513 522	100 ml		
11 513 788	500 ml		

# 12. Dimensions













## Space Requirements



## Height Compensation Plate\*

A height compensation plate was developed to raise the viewing height by 20mm or to raise the side camera ports for oversize cameras or spinning disks, or to use the microscope with an inactive bottom port on workbenches without openings. The height compensation plate is available in two versions (12mm and 25mm).

# 13. Abbreviations and Pictograms

	Contrast method
	Magnification
	Illumination
	Ports/Eyepiece
	Focus
6	Lower focus stop not set
6	Lower focus stop set
6	Focus position not set
6	Focus position set
	Shutter open
	Shutter closed
	Transmitted light filter
	Field diaphragm, rectangular
	Field diaphragm, round
33 	Aperture diaphragm
	Light distribution

### 13. Abbreviations and Pictograms

---

<b>AP</b>	Aperture diaphragm
<b>BF</b>	Brightfield
<b>COMBI</b>	Combination method
<b>CUBE</b>	Fluo cube
<b>DF</b>	Darkfield incident/transmitted light
<b>DIC</b>	Differential Interference Contrast
<b>FD</b>	Field diaphragm
<b>FLUO</b>	Fluorescence axis (incident light)
<b>ICR</b>	Interference contrast, incident light
<b>ICT</b>	Interference contrast, transmitted light
<b>IL</b>	Incident light
<b>INT</b>	Intensity
<b>PH</b>	Phase contrast
<b>POL</b>	Polarization, incident/transmitted light
<b>TL</b>	Transmitted light

# 14. Index

- Abbreviations 99
- Active ports 60
- Allen key 25
- Ambient temperature 10
- Analyzer 50, 51
- Analyzer slot 19
- Aperture diaphragm 16, 18, 61, 76, 90
- Arc 73
- Assembly tools 25
- Attachable mechanical stage 19
- Attachable mechanical stage for fixed micromanipulation stage 29
- Beam splitting** 84
- Bertrand lens 69, 84
- Booster lens 18, 43, 80
- Brightfield (TL) 76, 92
- Camera** 52
- Centering field diaphragm 20
- Centering keys 25
- Centering mercury lamps 72
- Centering procedure
- Centering window 19
- Changing the halogen lamp 40
- Changing the incident light lamp 44
- Cleaning glass surfaces 96
- Cleaning objectives 96
- Cleaning the stage 95
- C-Mount 0.5x/0.63x 52
- Coarse 83
- Collector 46, 47
- Color coding (objectives) 87
- Combination Methods 81
- Computer interface 54, 59
- Condenser 17, 50, 59
- Condenser base S1-S28 18, 34
- Condenser cable 53
- Condenser centering 67, 70
- Condenser head 18, 38
- Condenser head S1 34
- Condenser head S28 34
- Condenser height adjuster 17
- Condenser prisms 35, 36
- Condenser tool 36
- Condensers 14, 34, 37
- Consumable parts 97
- Contrast methods 12, 60, 76
- Contrast settings 67
- Controls 15, 55
- Correction for vision problems 85
- Corrective mount 87
- CUBE 63, 80
- Dark field (TL)** 77, 92
- Diaphragms 60
- DIC module 27
- DIC objective prism disk 18
- DIC objective prisms 27
- DIC specimen 79
- Differential interference contrast (TL) 79
- Digital camera 52
- DIN VDE 8
- Direct interface 53
- Discharge lamp 45, 74
- DM STC stage connections 32
- DRY 86
- Dust cover 95
- Electromagnetic compatibility** 8
- EU directive 8
- EXT1-EXT4 sockets 26
- Eyebase 84
- Eyepiece tube 18
- Eyepieces 16, 18, 39, 85
- Fast** 88
- Field diaphragm 17, 18, 90
- Field diaphragm 18, 61, 68, 76, 90
- Field diaphragm adjustment 68
- Field diaphragm centering 19
- Filter block 49
- Filter cubes 48, 49, 63
- Filter drawer 63
- Filters 17, 40
- FIM 89
- Fine 83
- Fixed function buttons 57, 61, 90
- Fixed micromanipulation stage 29
- Fixed stage 28, 30
- Fluo drawer 48
- Fluorescence 80, 94
- Fluorescence filter cubes 80
- Fluorescence illumination 81
- Focus 60
- Focus buttons 19, 63, 82
- Focus position 82
- Focus stop 63
- Focus wheel 16, 18, 19
- Focusing 82
- Focusing telescope 33
- Focusing telescope 69
- Frequency 10
- Front control panel 20, 21, 63, 89
- Function button assignment 58, 62
- Function buttons 58, 61, 62, 63

## 14. Index

---

Fuses 10

**General view** 21

Glass insert 31

Graticule 85

**Halogen lamp 12V 100W** 41

Handling acids and bases 96

Heating Insert P 31

Height compensation plate 98

Hg mercury burner 43

High-pressure mercury burner  
100W 44, 45

High-pressure xenon burner  
75 W 45

**IC condenser prisms** 36

IC prisms 27

Illumination 60, 65, 91

Image centering 66

IMM 86

Immersion objectives 86, 87

Immersion oil 97

Incident light lamp housing 19

Incident light turret disk 48

Incident light, fluorescence 68

Incident-light axis 12

Initialization 74

Insert frame for coverslips 33

Inserting the lamp 42

Inserts for attachable  
mechanical stage 30

Installation site 23

Intelligent automation 55

Intensity control 89

Intensity controls 16

Interfaces 15

Intermediate pupil interface 18

**Knobs** 57, 64

Koehler Illumination 65, 67

**Lamp bases** 45

Lamp housing 106 z (L) 42,  
44, 46, 71

Lamp housing 107 L 71

Lamp housing 107 or 107/2 41

Lamp housing for incident light 17

Lamp housing for transmitted  
light 17

Lamp housing receptacle 42

Lamp mount 18

Lamp power cable of stand 53

Lamp replacement 40

Leica CTR6000 electronics box  
10, 15, 17, 53, 59, 74

LeicaScreen 18

LeicaScreen 20, 56, 59, 60, 75, 94

Light intensity 18, 61

Light rings 34, 59

Light source adjustment 71

Light sources 89

Load 49, 64

Lower stop 63, 82

**Magnification** 60

Magnification changer  
13, 63, 89

Manual method (Pol) 78

Mechanical 3-plate stage 28

Medical instrument 8

Micromanipulation stage  
with attachable mechanical  
stage 28

Mirror housing 42

Motorized 3-plate or scanning  
stages 32

Motorized method (Pol) 78

Motorized polarizer 70

Multiple fluorescence 80

**Object displacement** 88

Objective aperture 77

Objective changing 85

Objective turret 13, 17, 19, 39

Objectives 17, 60, 85

Observation ports 14

Opening drawer 19

Operating mode 86

Operating temperature 11

Overvoltage category 10

**Parfocality** 39, 82

PCI card (PC) 52

Phase contrast 69

Phase contrast (TL) 77, 93

Phase contrast rings  
35, 36, 59, 69

Phillips screwdriver 25

Pictograms 99

Polarization (TL) 78, 93

Polarizer 50, 70

Polarizer holder 50

Pollution degree 10

Port 84

Port selection 84

Port switching 20

Power input: 10

Power supply 54

Precise 88

Protective gloves 44

Protective mask 44

**Reflector cubes** 71

Relative humidity: 10

Remote control module 21, 64

Removing immersion oil 96

Replacement eyecup 97

Replacement lamps 97

Replacement parts 97

Reset function 56, 75

Right side port 18, 19

Rotating stage 33

RS232 ports 53

- Safety class 9
- Safety regulations 9
- Screw lengths 29
- Setting stops 82
- SHUTTER 63, 80
- Side port 19
- SmartMove 21, 55, 57, 64
- Software 57
- Software tools 15
- Specifications 10
- Stage positions 88
- Stages 13, 19, 88
- Stages and accessories 17, 28
- Stand 16, 91
- Stand package 22
- Step increments 83, 88
- Stops 60
- Supply unit ebq 100
  - 10, 46, 47, 54, 74
- Supply voltage 10
- Switching on the microscope 59
- System package 22
  
- Three-plate micromanipulation stage 28
- TL/IL switching 18
- Toggling transmitted light/incident light 61
- Top port 18, 20
- Transmitted illumination 81
- Transmitted illumination-unit 17
- Transmitted light 65
- Transmitted light interference contrast 93
- Transmitted light lamp housing
  - 18, 40
- Transmitted-light axis 12
- Transmitted-light filter 20
- Transmitted-light illumination carrier 26
- Transmitted-light specimen
  - 76, 77
- Transportation 24
- Tube 12, 16, 84
- Tube setting 84
- Turret disk 49
  
- USB** 53
- Useful life of lamps 45
  
- Variable function buttons**
  - 18, 19, 21, 57, 62
- Variable function buttons on SmartMove 64
- Viewing angle 84
  
- Xe** 75 burner 46
- XYZ-Control 53
  
- Z** focus 14