

SONY



MA900 Multi-Application Cell Sorter

Sony Biotechnology Inc.



MA900 Multi-Application Cell Sorter

Sorting Made Simple™

The MA900 from Sony meets the needs of most sorting applications, supporting 12 fluorescence parameters and 4-way sorting. Powerful, modern technologies built into the MA900 system include a patented microfluidic chip-based design, comprehensive fluidic controls, and advanced automation that dramatically simplifies operation to make sorting less subjective and improve reliability.

Up to 14 parameters from 4 lasers

The MA900 offers choice and flexibility, enabling the detection of up to 14 parameters. Choose from 4 excitation lasers—488 nm, 638 nm, 405 nm, and 561 nm—on two beam spots. Free-form PMTs enable detection of fluorescence signals from each beam spot, allowing detection of up to 12 fluorescence parameters and 2 scatter parameters.

Automation across the workflow

The MA900 offers a high level of automation. Startup, aseptic cleaning, QC, and sort setup operate with a touch of a button to ensure optimal daily alignment of the chip to the lasers, precise targeting, and fast recovery from clogging. Wizard based cleaning cycles simplify maintenance and can be customized for aseptic sorting.

Easy to learn and use

The MA900 software guides operation. Advanced controls enable customization, and powerful tools let you focus on the biology, not the cytometer.

Precision
benchtop
system that is
easy to use and
supports 12
fluorescence
parameters and
4-way sorting



A compact 21.7" (55 cm) x 21.7" (55 cm) x 28.4" (72 cm) footprint to fit easily on the benchtop

Automation

With the highest level of automation available on any cell sorter, the MA900 uses sensors, software, and engineering know-how across the workflow from startup to aseptic cleaning, QC, and sort setup. Intelligent automation dramatically simplifies operation and streamlines troubleshooting.



Initiation

Upon startup, the software initiates connection between all subsystems and runs diagnostics that ensure that everything is working properly. Once the subsystems are verified, the software displays status and a green ready message on the instrument's LCD monitor.

Startup automation ensures optimal daily alignment of the chip to the lasers

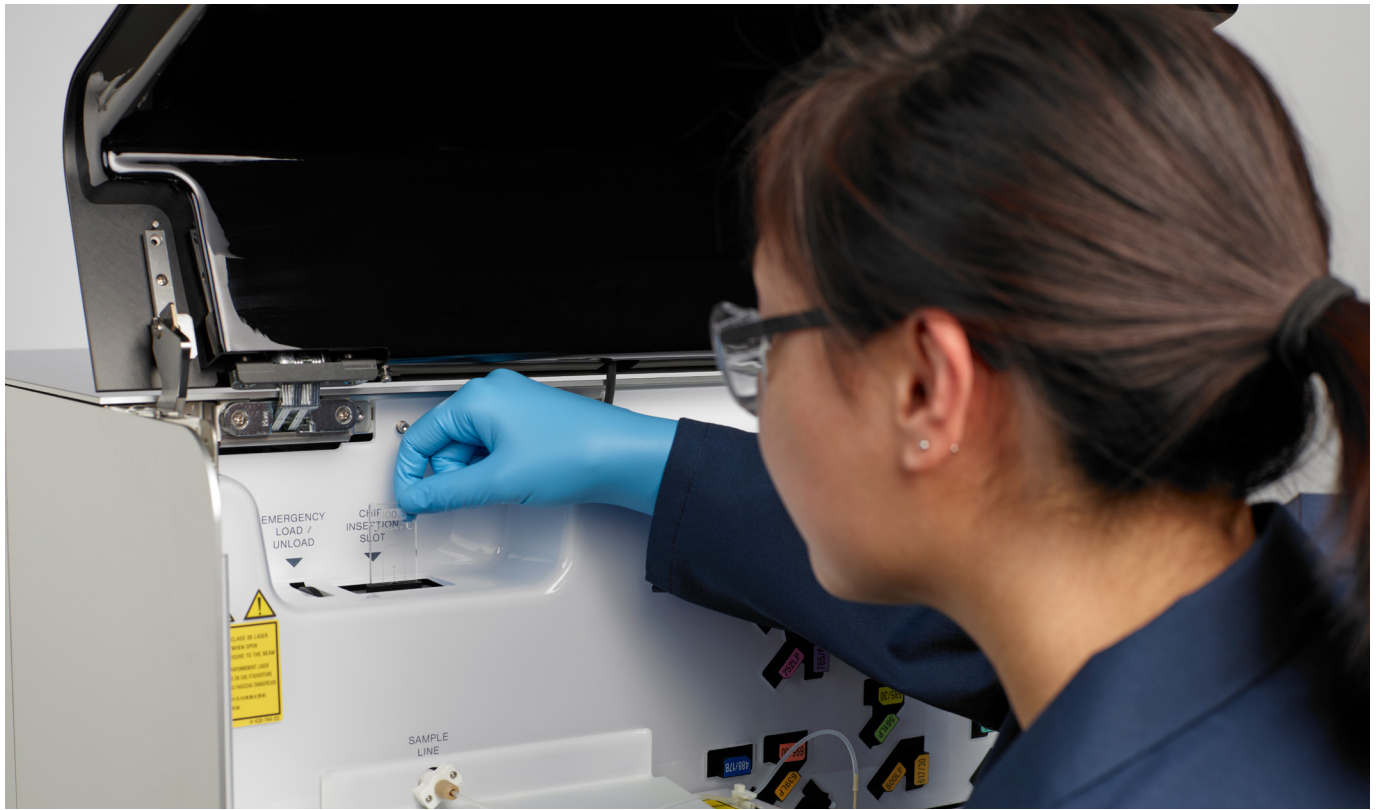

Automated Chip Loading and Positioning

System setup begins with a one-touch installation to load the microfluidic flow cell chip. A setup software wizard guides you through the process of loading a sorting chip, selecting lasers, and inserting the optical filters required. Actuators ensure precise positioning of the chip inside the chip loader. The microfluidic sorting chip uses patented CoreFinder™ technology to automate and streamline key steps in the workflow including chip alignment and accurate calculation of the laser delay, drop delay, side stream angle, and breakoff position.

Once the chip is loaded, the fluidics check starts, and sheath, sample, and vacuum lines connect and seal automatically to their respective ports.

Automated Optical Axis Adjustment

The alignment of the chip to the lasers is optimized automatically using patented technology. AutoSetup beads are used daily to adjust the X and Z position of the chip to ensure consistent results.

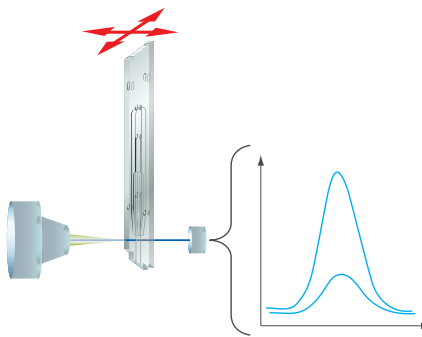

Automated Droplet Calibration

The droplets are automatically calibrated by adjusting the frequency and the drop drive to achieve an optimal breakoff point (BOP) for the 70- μm , 100- μm , and 130- μm sorting chips.

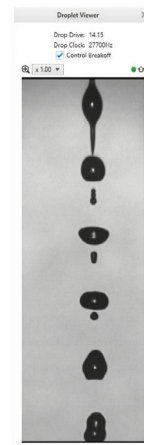

Software-driven workflows from calibration to cleaning

Automated Side Stream Calibration

The angle and the position of the side streams are calculated and adjusted during setup for tube and plate sorting. This ensures that the sort stream is centered in the collection tube automatically.

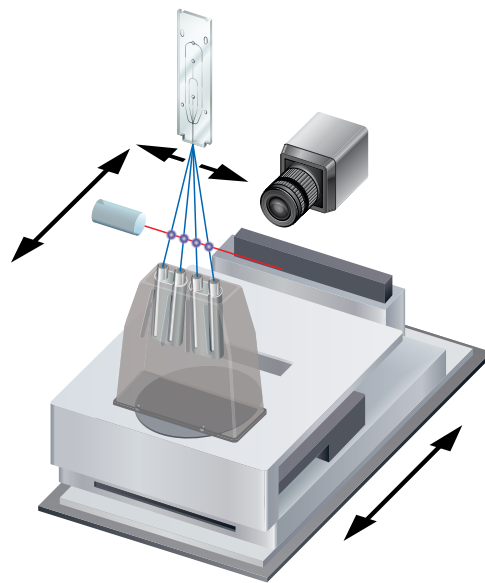

Automated Drop Delay Calibration

A dedicated laser and camera perform real-time analysis of droplet images using AutoSetup beads. Patented technologies calculate drop delay to ensure cells are sorted to desired purity and yield.

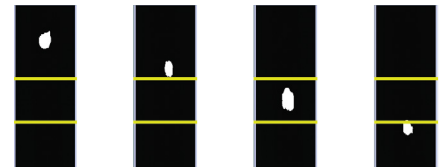

Automated Quality Control

Using QC beads, the rCV and linearity are measured and can be displayed in Levey-Jennings plots. This information helps administrators accurately assess optical performance over time.

Automation

Automated Fluid Sensing

The fluidics cart houses autoclavable sheath, deionized water, and waste tanks as well as tanks containing bleach and ethanol. Weighted sensors on the fluidics cart allow a real-time measurement of the fluid levels, which is displayed in the software.

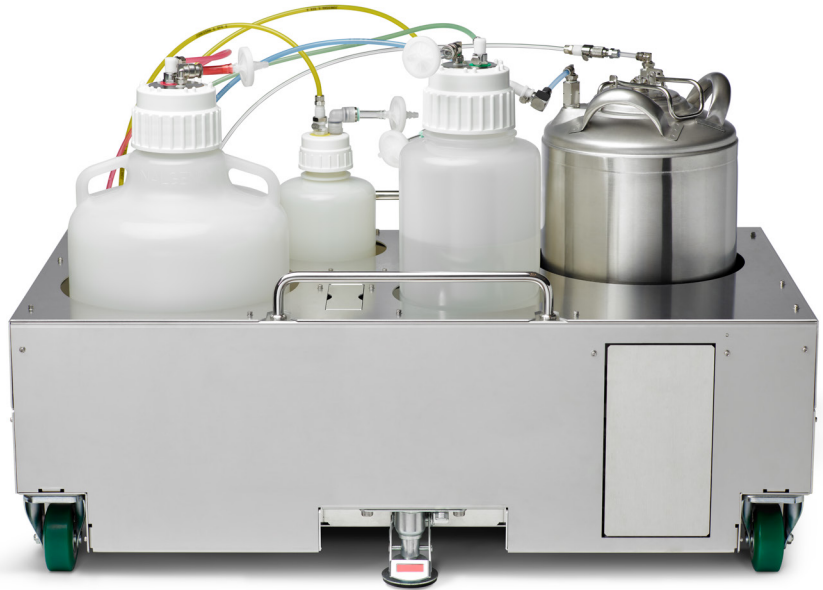

Wizard-Driven Cleaning Cycle

Software guides the operation of default and custom fluidic system cleaning. Default cycles include cleaning with bleach or ethanol. Software guides you through each step of the selected cleaning cycle. Fluid is pumped from three cleaning tanks via a cleaning chip. The software also supports user-defined protocols for setting the time for cleaning. In addition, cleaning reminders can be set up by administrators for convenience.

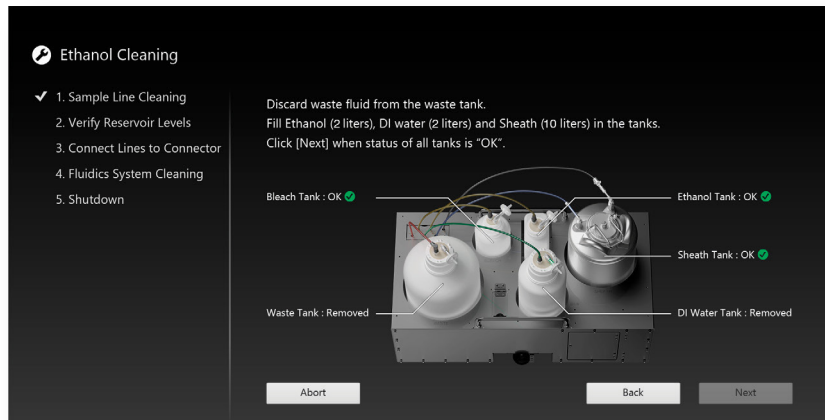

Sorting

Once events are gated on plots, target cells can be sorted for further analysis. Sort mode, sort gates, and sort devices can be assigned using a simple dialog box. A choice of eight default and five custom sort modes is available to achieve the desired purity and yield of the sorted population. Sort devices supported include: 2-way and 4-way tubes as well as 6-, 12-, 24-, 48-, 96-, and 384-well plates.



Experiment Settings

Experiments can be created by selecting a new template, a recent experiment, or a shared template (public) from the experiment window. If a new template is selected, the software guides you through choosing experiment settings such as sample groups, tubes, and pulse parameters for data acquisition. Once a template is selected or created, compensation data can be acquired easily by using the software based compensation wizard. Alternatively, uncompensated populations can be adjusted using the drag and drop feature in the software.

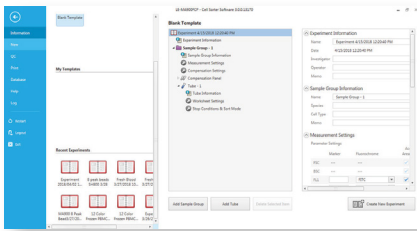

Data Display and Using Gates

During acquisition, data is displayed on worksheets as dot plots and histograms. Events in the plots can be marked using gates. A variety of tools are provided to select, adjust, label, and measure statistics of target populations. Once acquired, data can be easily exported as FCS formats to use with third party analysis software.

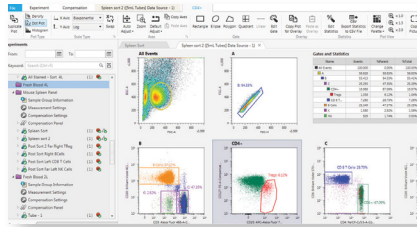

Automated Sort Monitoring

The software monitors and actively makes adjustments to the drop drive to maintain a stable breakoff point. This feature ensures consistently good sort performance, facilitates walk-away operation, and allows detection of clogs and empty tubes.

Precision engineering for accurate cell deposition and easy to use index sorting software

Index Sorting Software

Index sorting software records the X and Y coordinates of each event sorted into a multiwell device. This very precise and easy to use software brings powerful capabilities to research, enabling you to track the scatter and fluorescence intensity of individual cells sorted in each well.

After the sort, the index file can be exported in CSV format or analyzed on the cell sorter. The Well Select feature lets you choose a well and display event(s) sorted in that well on bivariate plots and histograms. The Gate Select feature lets you display the location of events on a plate map based on a selected gate.

These index sort options allow you to perform meta-analysis of data for several applications. For example, clonal variability can be studied based on the expression levels of the fluorescent protein or surface markers. Also, researchers can integrate phenotypic data with mRNA expression analysis of the sorted cells.

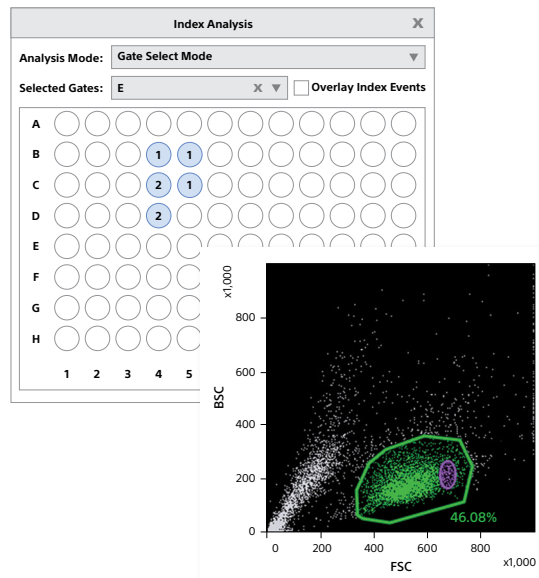
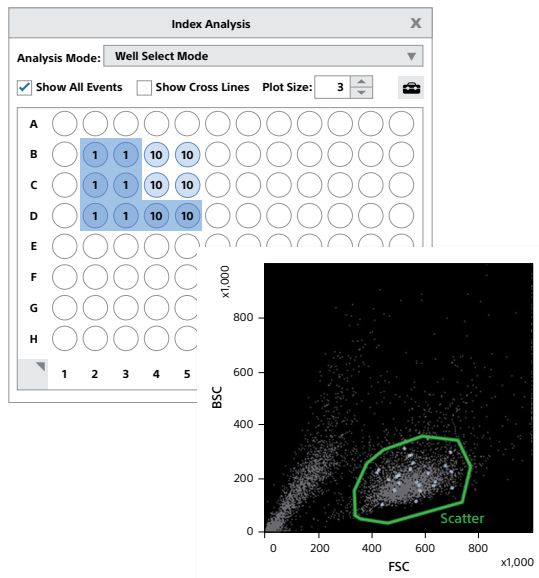

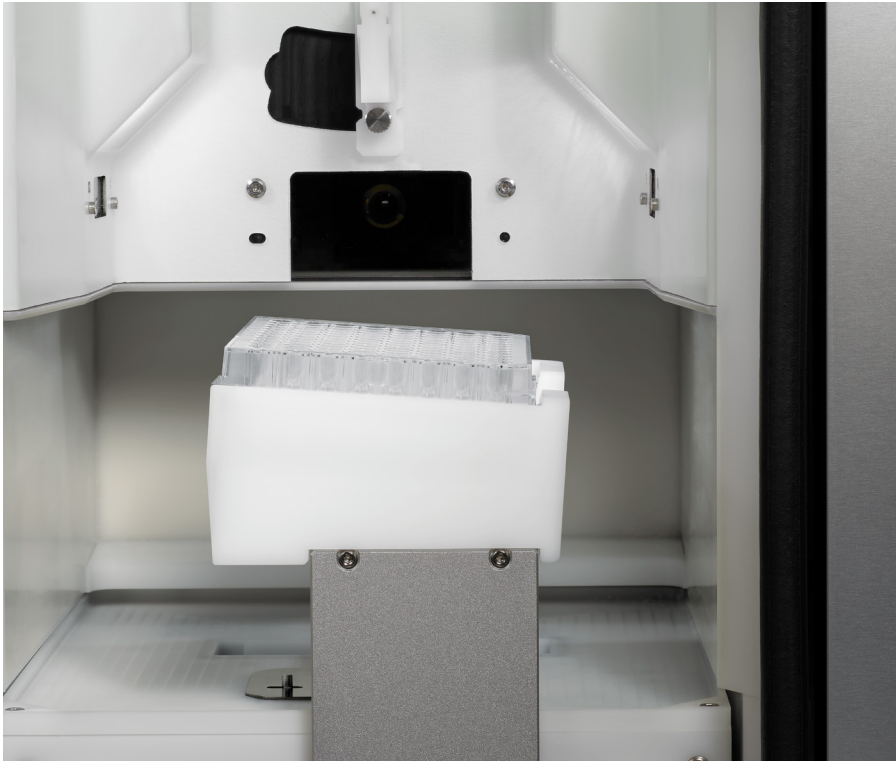

Sort Deposition System

The Sort Deposition System is an optional hardware feature that facilitates high-throughput sorting and precise deposition of cells into 6-, 12-, 24-, 48-, 96-, and 384-well plates or PCR plates. Several features on the MA900 enable deposition of single cells at a high efficiency. These include the ability to precisely adjust the position of a plate, assign the center of the drop relative to the target cell position, and utilize custom angled plate holders for multiwell PCR and 384-well plates.

Applications

High-purity 4-way sorting of a 12-color immunophenotyping panel

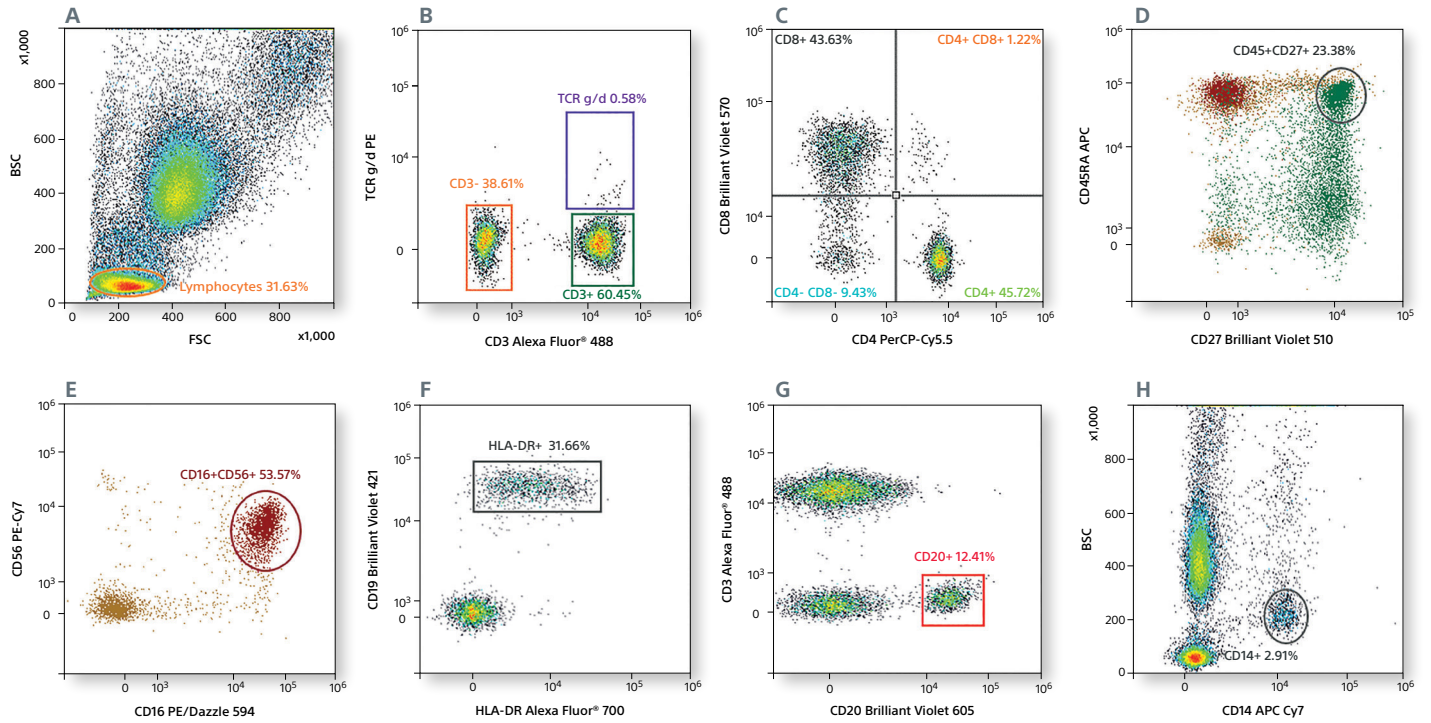

Engineered for flexibility to fit a wide range of applications

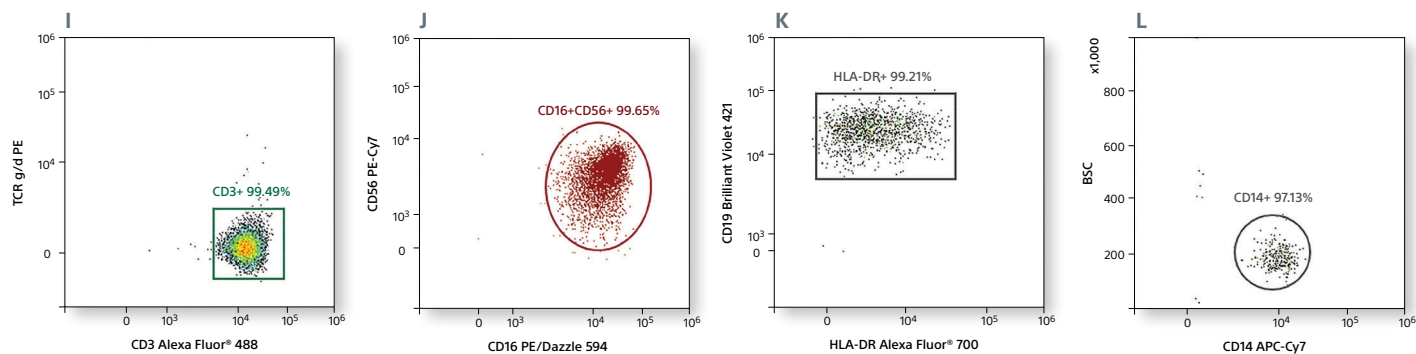

Whole blood was lysed with RBC Lysis Buffer and stained with Alexa Fluor[®] 488 CD3, PerCP-Cy[™]5.5 CD4, BD Horizon Brilliant[™] Violet 570 (BV570) CD8, APC-Cy[™]7 CD14, PE/Dazzle[™] 594 CD16, BV421 CD19, BV605 CD20, BV510 CD27, APC CD45RA, PE-Cy7 CD56, Alexa Fluor[®] 700 HLA-DR, and PE TCR gamma/delta antibodies. Cells were incubated for 20 minutes on ice, washed 2X with staining buffer, and analyzed on the MA900 equipped with 488-nm, 405-nm, and 638-nm lasers.

Scatter was used for gating lymphocytes (A). The CD3+ population (B) was used to gate CD4+ and CD8+ cells (C). CD4+ T-cell subsets were identified based on CD45RA and CD27 expression (D). CD16+CD56+ NK cells were gated from CD3- cells (E). CD19+CD20+ B cells were gated from CD3- cells (F), and the HLA-DR expression of B cells was analyzed (G). CD14+ monocytes were identified based on scatter (H). CD3+ T cells, CD19+CD20+ B cells, CD16+CD56+ NK cells, and CD14+ monocytes were sorted by 4-way sorting. Post-sort analysis of each sorted population is shown (I-L).

Applications

Ease-of-use from multicolor to single-cell analysis

High-purity 4-way sorting of a 12-color immunophenotyping panel

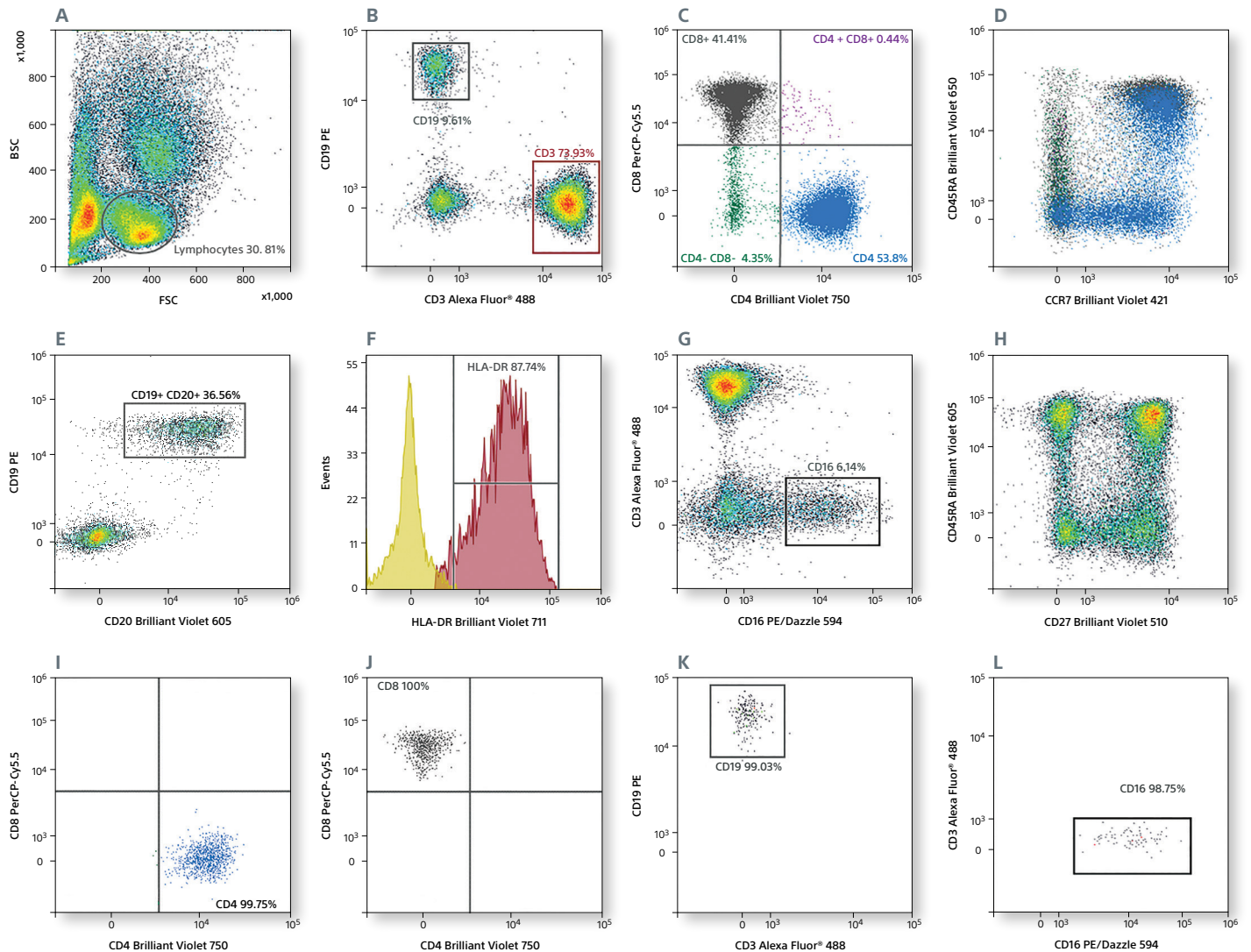

Whole blood was lysed with RBC Lysis Buffer and stained with the following antibodies: Alexa Fluor® 488 CD3, PE CD19, PerCP-Cy5.5 CD8, PE/Dazzle 594 CD16, BD Horizon Brilliant Violet 421 (BV421) CCR7, BV510 CD27, BV605 CD20, BV650 CD45RA, BV711 HLA-DR, and BV750 CD4. Cells were incubated for 20 minutes on ice, washed 2X with staining buffer, and analyzed on the MA900. Lymphocytes were gated using the scatter gate (A).

The CD3+ population (B) was used for gating CD4+ and CD8+ cells (C). CCR7+CD45RA+ lymphocytes are shown in (D). CD19+CD20+ B cells were gated from lymphocytes (E), and the HLA-DR expression of B cells was analyzed (F). CD16+ NK cells (G) were gated from lymphocytes. CD27 expression of CD45RA+ subsets of lymphocytes was analyzed (H). Using the 4-way sort mode on the MA900 cell sorter, CD4+ and CD8+ T cells, CD19+ B cells, and CD16+ NK cells were sorted. Post-sort analysis of each sorted population is shown (I-L).

High-purity sorting of regulatory T cells

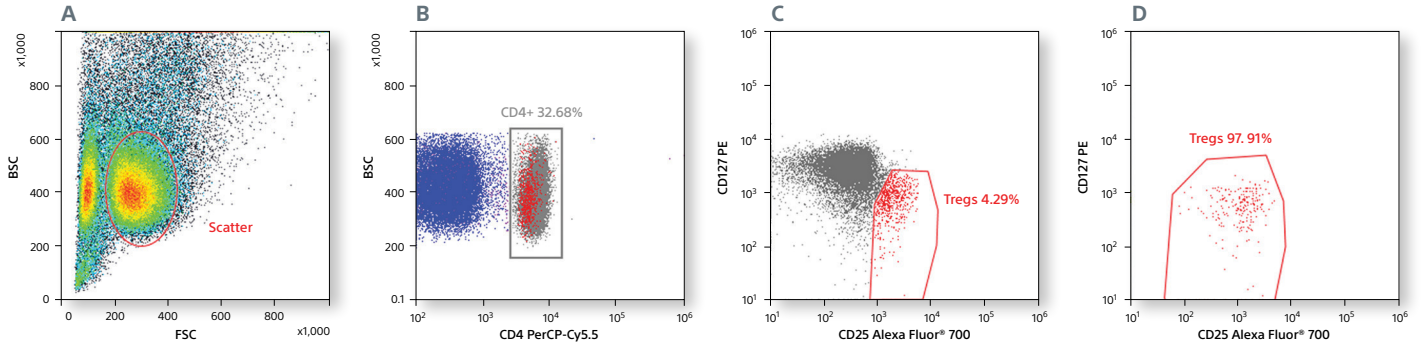

Mouse spleen cells were stained with following antibodies: CD4 PerCP-Cy5.5, Alexa Fluor® 700 CD25, and PE CD127. Cells were incubated for 20 minutes on ice, washed 2X with staining buffer, and analyzed on the MA900. Live spleen cells were gated using the scatter gate (A). The CD4+ population (B) was used to gate CD4+CD25^{int}/highCD127^{low} regulatory T cells (C). These cells were sorted using the MA900. Post-sort analysis of the sorted regulatory T cells is shown (D).

Cell cycle analysis of Jurkat cells

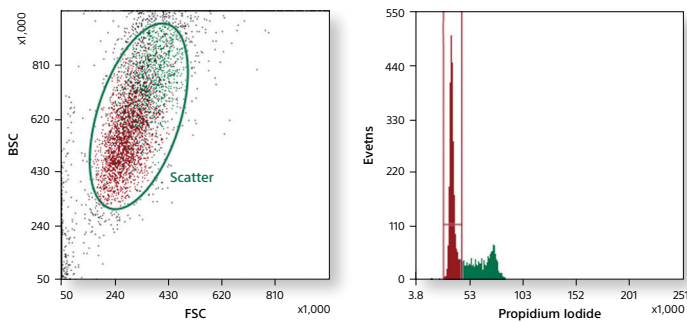

Jurkat cells were stained using Propidium iodide (1 µg/mL), and cell cycle analysis was performed using the MA900.

Applications

Biosafety Options



If desired, the MA900 can be installed inside an optional custom class A2 level II biosafety cabinet for protection for personnel and products. The custom biosafety cabinets offered by Sony Biotechnology are designed and tested by their manufacturers using microbiological assays with the MA900 in the work area. The cabinets meet inter-national standards including the National Sanitation Foundation Standard 49 (NSF49) and the European Standard 12469.

The cabinets incorporate a built-in aerosol management system which operates independently to actively evacuate aerosols from the sort collection chamber. The dual routes of aerosol evacuation maximize protection.

Biosafety

Fluorochrome and Filter Guide

Fluorochrome		FL1 525/50	FL2 585/30	FL3 617/30	FL4 695/50	FL5 785/60	
EGFP		●					
FITC		●					
Alexa Fluor® 488		●					
EYFP		●					
mCitrine		●					
CFSE		●					
PE			●				
dsRed			●				
tdTomato			●				
mCherry				●			
PE-Texas Red®				●			
PE/Dazzle 594				●			
Propidium Iodide				●			
mPlum					●		
7-AAD					●		
PE-Cy™5					●		
PerCP					●		
PE-Cy5.5					●		
PerCP-Cy5.5					●		
PerCP-eFluor 710					●		
PE-Cy7						●	
	FL6 450/50	FL7 525/50	FL8 585/30	FL9 617/30	FL10 665/30	FL11 720/60	FL12 785/60
BD Horizon Brilliant Violet (BV421)	●						
Alexa Fluor® 405	●						
DAPI	●						
Pacific Blue™	●						
mCFP	●						
Hoechst 33342	●						
AmCyan		●					
BV510		●					
BV570			●				
BV605				●			
BV650					●		
BV711						●	
BV785							●
APC					●		
Alexa Fluor® 647					●		
APC-Cy5.5						●	
Alexa Fluor® 700						●	
APC-Cy7							●
APC-Alexa Fluor® 750							●

Filter Guide

Specifications

Optics	Excitation lasers	488 nm, 638 nm, 405 nm, 561 nm
	Output power	Optical fiber output : 405 nm: (10 mW max.), 488 nm, 638 nm, and 561 nm: (36 mW max.)
	Beam alignment	Dual axis optical system
	Detection parameters	12 fluorescence + 2 scatter
	Pulse measurement	Height, Area, Width
Fluidics	Sample tube	Single, auto-loading tube
	Tube types	0.5-mL, 1.5-mL, 5-mL, and 15-mL tubes
	Sort devices	2-way tube, 4-way tube, multiwell plates, PCR plates
	Temperature control	5°C, 37°C (electric cooling method)
	Agitation unit	Eccentric rotation
	Magnetic drive	300-rpm speed
	Sorting chip size	70 µm, 100 µm, 130 µm
Sort Performance	Event rate	70,000 eps
	Sorting speed	Automated frequency search range <ul style="list-style-type: none"> • 70 µm : 40 kHz to 52 kHz • 100 µm [Targeted] setting : 21 kHz to 23.5 kHz • 100 µm [Standard] setting : 27 kHz to 31 kHz • 130 µm : 10 kHz to 12 kHz Using the 70-µm sorting chip at 52 kHz and a threshold rate of 12,000 events per second, purity >98% and recovery >80% can be achieved. The yield obtained is based on Poisson's statistics. Higher threshold events per second can be achieved without affecting purity but with a decrease in yield based on Poisson's statistics.
	Scatter resolution	0.5 µm
	Fluorescence resolution	<3.0% coefficient of variation (CV): PI stained CEN
	Fluorescence sensitivity	FITC ≤94 MESF, PE ≤88 MESF
Ancillary	Dimensions	W: 21.7" (55 cm) x D: 21.7" (55 cm) x H: 28.4" (72 cm)
	Fluidics cart	W: 33.9" (86 cm) x D: 17.3" (44 cm) x H: 11.8" (30 cm)
	Weight	231 lb (105 kg)
	Fluidics cart	108 lb (49 kg) (dry weight)
	LCD panel	7-inch, 800 x 480 pixels
	Power supply	100–240 V, 50/60 Hz
	Power consumption	600 W (max.)
	Operating temperature	19.5°C to 27.5°C
	Relative humidity	20% to 80%
Compliance	Operating system	Microsoft® Windows® 10 Professional, 64 bit
	Data file structure	Flow Cytometry Standard (FCS) 3.0 or 3.1
	Safety standards compliance	UL, CE, CSA



North America/International

1730 North First Street
San Jose, CA 95112 U.S.A.
Tel: +1 800-275-5963
Fax: +1 408-352-4130
SBTCustomerService@sony.com
www.sonybiotechnology.com

Japan

5-1-1, Minato Mirai, Nishi-ku,
Yokohama-shi, Kanagawa,
220-8750 Japan
Tel: +81 120-677-010
Fax: +81 120-388-060
sales_Japan@sonybiotechnology.com
www.sony.co.jp/LS

China

301,3/F, Commercial Podium,
Ping An International Financial Center
No. 1 South Xinyuan Road,
Chao Yang District
Beijing 100027, P.R. China
Tel: +86 400 619 7910
fcm@sony.com.cn

Europe

The Heights, Brooklands.
Weybridge, Surrey,
KT13 0XW, UK
SESSalesSupport@sony.com