

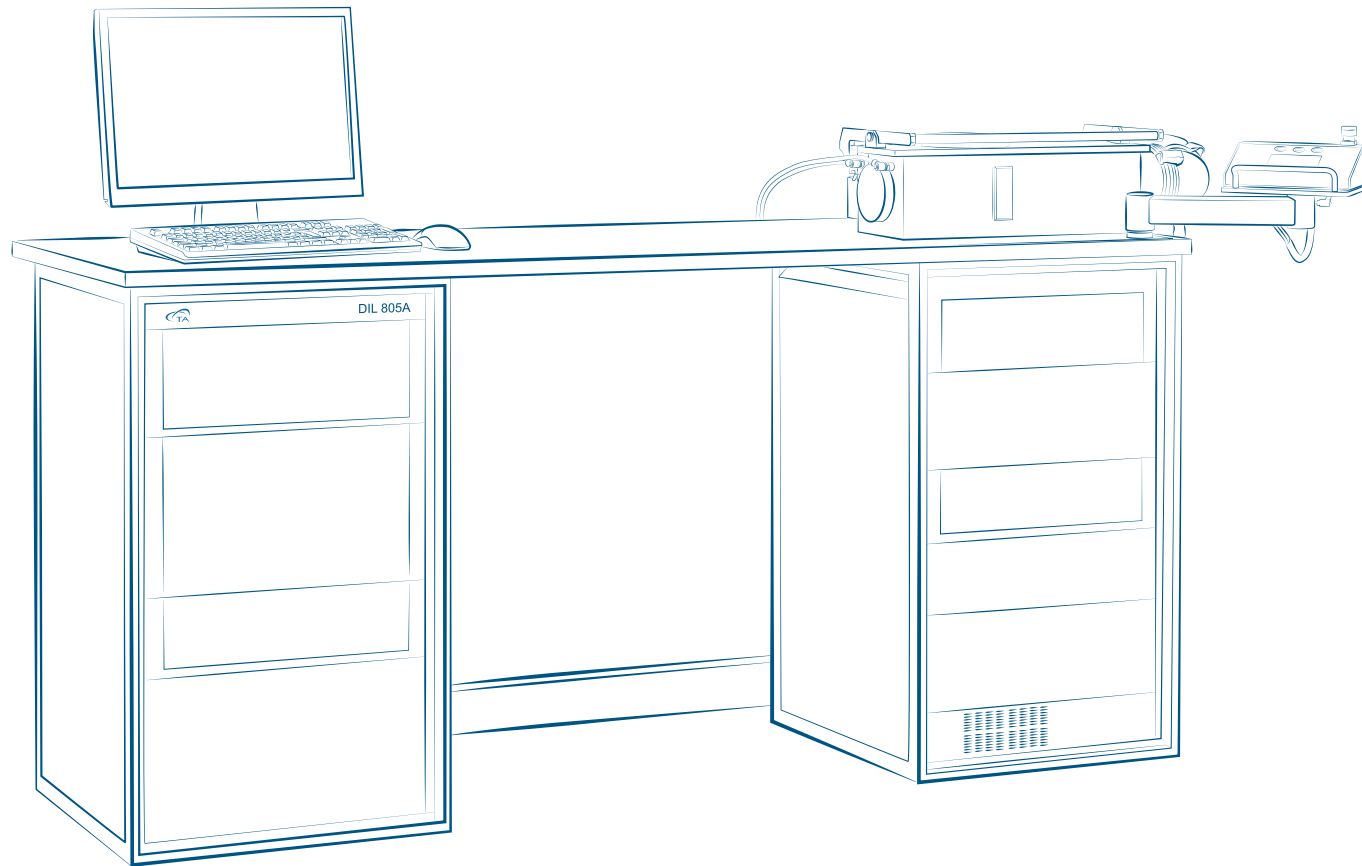

QUENCHING DILATOMETRY



Quenching and Deformation Dilatometer

In the processing of metal alloys, the quenching rate, isothermal dwell times, and deformation cycles dictate the final crystalline structure and resultant physical properties. These microstructural changes may be observed through direct process simulation with real-time monitoring of dimensional change, which reflect phase transitions. The measurement of distinct alloy compositions allows the creation of, among other things, Time-Temperature Transformation diagrams (TTT) and Continuous-Cooling Transformation diagrams (CCT), which are critical for process design and optimization.

The DIL 805 Series quenching and deformation dilatometers provide the most accurate measurements over the widest range of heating, cooling, and deformation conditions, for the most sophisticated characterization and optimization of metals processing. Featuring powerful inductive heating, a unique helium quench system, absolute optical measurements, and direct global support, the DIL 805 Series are the instruments of choice for process laboratories testing metals and alloys.

DIL 805 | QUENCHING DILATOMETER

The 805 Series Quenching Dilatometers are the benchmark instruments for scientists and engineers interested in determining dimensional changes and phase transformations of steel alloys. Extremely flexible and configurable, the DIL 805 Series is designed to accommodate a wide range of add-on modules enabling it to be tailored to specific user requirements. It is the most powerful and versatile tool for the determination of critical parameters in steel manufacturing and heat treatment processes.

Features and Benefits:

- Proprietary design of induction heating coil allows ballistic heating and cooling rates and enables in-laboratory tests closely simulating production processes to characterize the response of materials during industrial heat treatments .
- Two models for quenching dilatometry and two optional deformation modes (both for compression and tensile loading) to match the requirements of any R&D, Method Development or Production Support laboratory
- Temperature range of -150 °C to 1700 °C offered in two temperature configurations ensure fit-to-purpose
- Scalable design supports full operations yet allows budget planning
- Optical Module for contact-less, cross-section dilatometric measurements to study anisotropic effects
- WinTA software platform with advanced graphics functionalities to develop phase transition diagrams, including Continuous-Cooling-Transformation (CCT), Isothermal Time-Temperature-Transformation (TTT), and Time-Temperature-Transformation after Deformation (DTTT), combining multiple cooling or isothermal curves.



DIL 80L
Quenching and Deformation Dilatometer



DIL 805A/D/T
Quenching Dilatometer

SCALABLE DESIGN MAXIMUM PERFORMANCE

Quenching Mode to Determine Phase Transformations of Steel and Alloys

The quenching dilatometer mode allows the user to create laboratory tests that replicate response of the steel and alloys during the actual processing conditions. Designed to accommodate many different add-on modules, the DIL 805 series are powerful and versatile tools for the determination of critical parameters in steel manufacturing and heat treatment processes.

Proprietary Induction Heating Coils

The wide selection of proprietary induction heating coils allows for rapid heating at rates up to 4000 °C/sec and cooling rates exceeding 4000 °C/sec. Only the sample is heated so there is no associated furnace/insulation cool-down period allowing another sample to be loaded immediately upon test completion. The hollow-core inner coil also serves as the purge gas conduit focused at the heating zone, ensuring an inert environment throughout the test.

Deformation Mode Provides Knowledge for Steel Processes such as Hot or Cold Rolling

With the deformation module, solid samples are compressed using various programs (e.g. linear, multi-level with a constant deformation force or rate) with controlled forces up to 20 kN or rates up to 200 mm/s. An unlimited number of deformation steps can be performed with a pause between steps of only 60 ms. This unique technology enables the control of cooling and deformation processes allowing creation of DTT diagrams. The 805A/D can also be used to examine creep and relaxation processes.

Tension and Compression Modes for Force-controlled, Strain-controlled, and Tensile Loading to Fracture Cycles

The deformation mode can be expanded to provide alternating tensile and compressive loading. The expansion of a clamped flat, dogbone-shaped sample is measured during heating or cooling to emulate mill processing. Once the desired temperature is achieved, it is held isothermally while the desired mechanical cycling is performed. Force-controlled or strain-controlled cycles are available up to 10 kN or 20 mm/s, respectively. Additionally, tensile loading to fracture lends additional information about the final performance characteristics of the material. These data are used to generate true-stress vs. true-strain or stress/strain cycling plots.

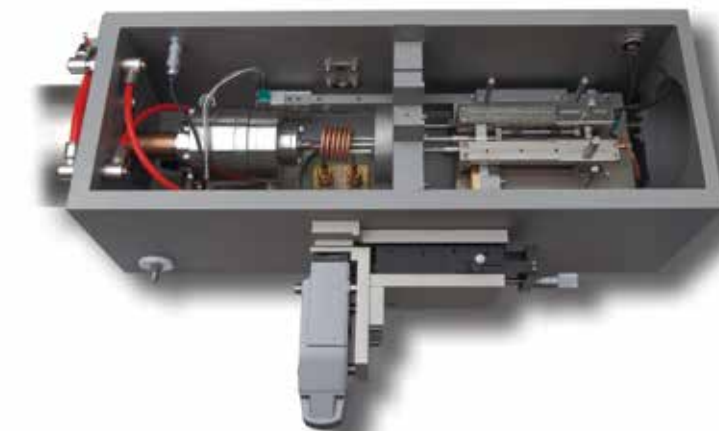

DIL 805 A/D/T Measuring Head

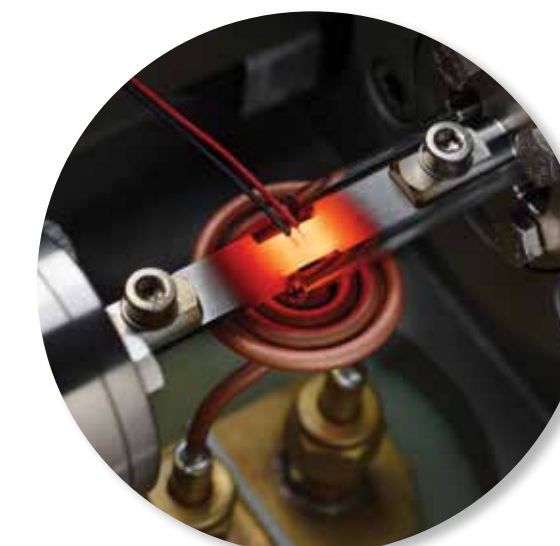

DIL 805 Induction Coil for Tensile Measuring Head

DIL 805 SERIES | TECHNOLOGY

Sub-zero Module

In many cases, the martensitic finish temperature, M_f , of a steel lies well below room temperature. This add-on module operates from -160°C to 1300°C , with attainable controlled quenching rates in excess of $4000^{\circ}\text{C}/\text{sec}$, and allows for the complete characterization of the austenite to martensite transformation. This unique quenching technology passes helium gas through a copper heat exchanger submersed in a liquid nitrogen bath before delivery to a hollow sample. The design greatly improves heat transfer by eliminating many of the issues associated with liquid nitrogen cooling, including condensation, material interaction, and imprecise response rates.



Alpha Measuring System with True Differential™ measuring head and Sub-zero module

Alpha Measuring System

The Alpha measuring head allows the DIL 805 Quenching Dilatometer to be used for traditional push-rod dilatometer studies such as the determination of the Coefficient of Thermal Expansion (CTE) and the softening point. Low-expansion fused silica components, in conjunction with TA Instruments unique True Differential™ measuring head design, provide high-precision expansion measurements.

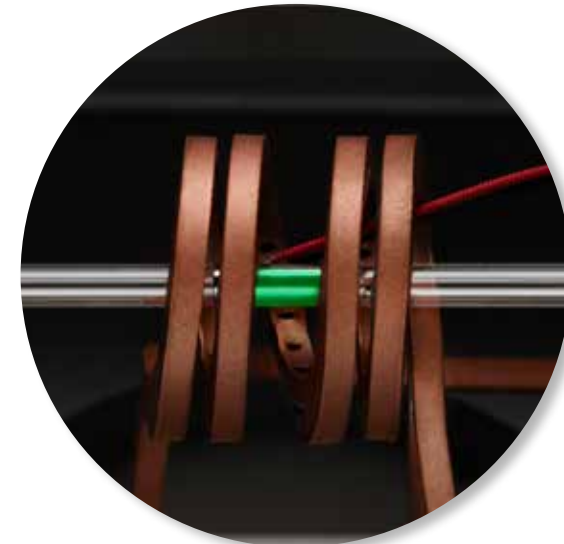

Optical Module for contact-less measurement of cross-section dimensional changes

Optical Non-Contact Dilatometer

Traditional dilatometers measure the thermal expansion of a material in one axial direction and have an inherent drift associated with the thermal interaction at the contact point between the push-rod and the sample, especially during isothermal dwells. With the optical expansion module, contraction/expansion is monitored in two directions during the test run. The measurement is non-contact and absolute, so it is free from interaction with dilatometer temperature gradients and a calibration correction is not necessary. The optical module is available for the quenching, deformation, and tension/compression configurations, and produces results that are unachievable by conventional methods.

Thermocouple Placement Apparatus

Precise temperature control requires temperature monitoring adjacent to the sample. The easy-to-use thermocouple placement device reproducibly spot welds up to three thermocouples directly onto the sample for temperature resolutions of 0.05°C across the full temperature range. The welding current and time, the contact pressure, and the inert gas purge can be adjusted to ensure a strong spot weld onto the sample.



The flexible, easy to use Thermocouple Placement Apparatus

Heating Ring for Non-thermally Conductive Samples

Often, non-ferrous materials are not electrically conductive and cannot be heated by induction. Specially designed heating rings, in platinum or molybdenum, are also available to enable testing these materials.

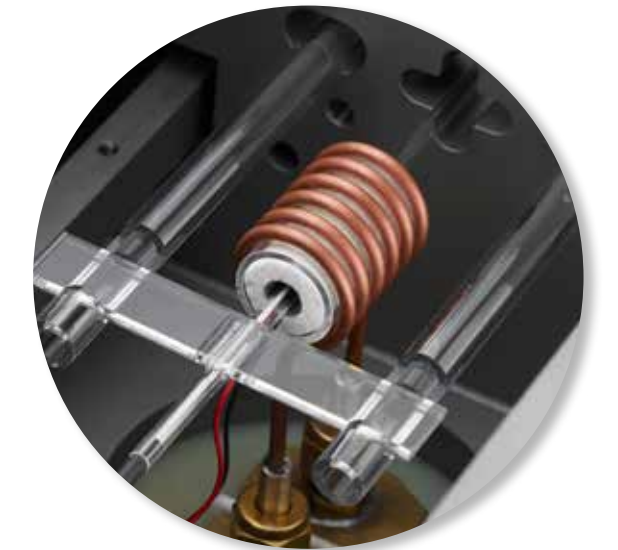

Platinum Heating Ring for non-electrically conductive materials

QUENCHING DILATOMETER | SPECIFICATIONS

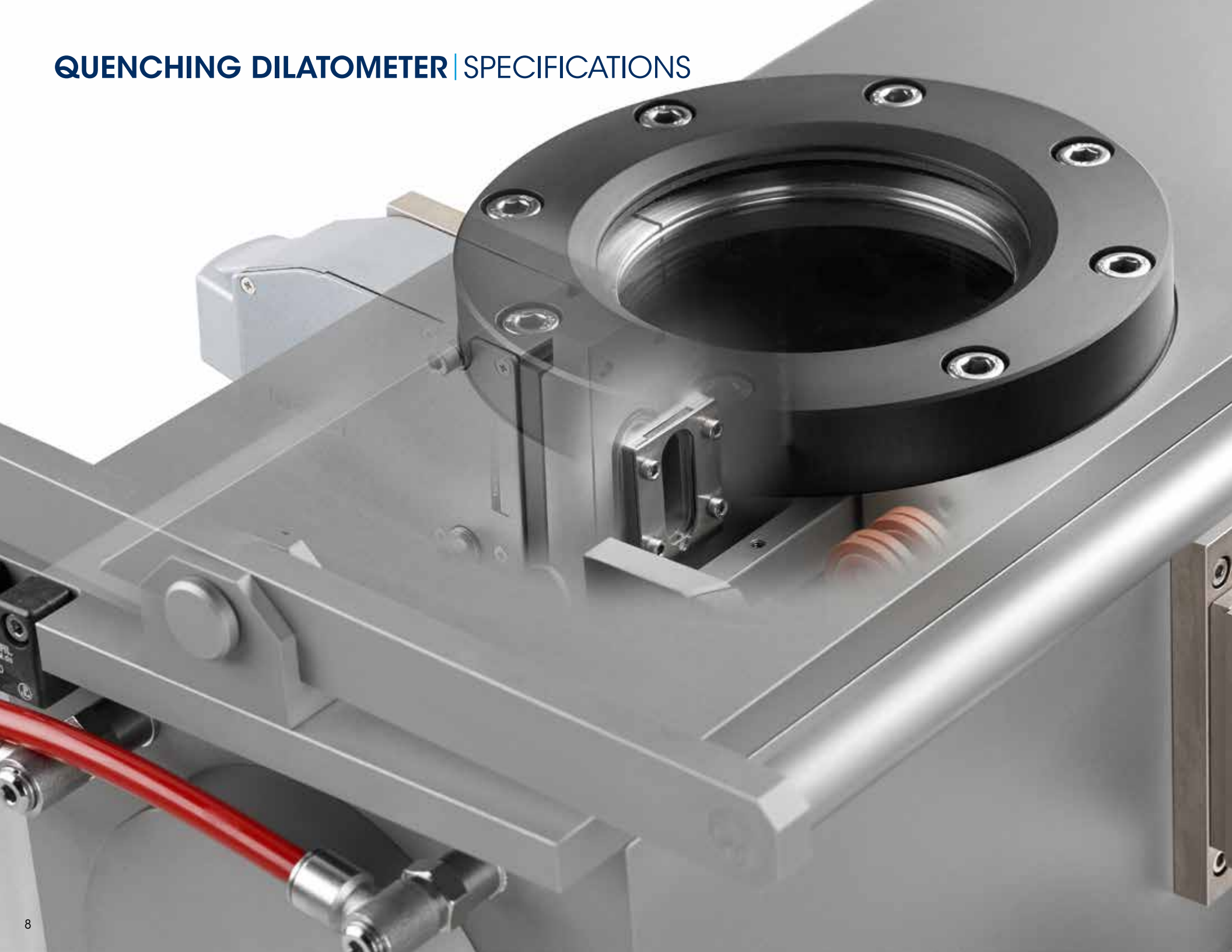

	DIL 805L	DIL 805A	DIL 805A/D	DIL 805A/D/T
Temperature Range	-150 °C to 1300 °C 20 °C to 1500 °C	-150 °C to 1300 °C 20 °C to 1700 °C	20 °C to 1700 °C	20 °C to 1700 °C
Heating Principle	Inductive heating with constant sinus frequency	Inductive heating with constant sinus frequency	Inductive heating with constant sinus frequency	Inductive heating with constant sinus frequency
Heating Rate	≤ 4000 °C/sec	≤ 4000 °C/sec	100 °C/sec	100 °C/sec
Cooling Rate	≤ 4000 °C/sec	≤ 4000 °C/sec	≤ 100 °C/sec	≤ 100 °C/sec
Sample Material and Geometry	Electro-conductive solid or hollow samples OD=4 mm, L=10 mm	Electro-conductive solid or hollow samples OD=4 mm, L=10 mm Optional OD 1 mm to 22 mm	Electro-conductive solid samples OD=5 mm, L=10 mm Optional OD 1 mm to 22 mm	Electro-conductive solid samples OD=5 mm, L=10 mm Optional OD 1 mm to 22 mm
Atmosphere	Air, vacuum, inert gas	Air, vacuum, inert gas	Air, vacuum, inert gas	Air, vacuum, inert gas
Resolution ($\Delta L / ^\circ C$)	0.01 μm / 0.05 °C	0.01 μm / 0.05 °C	0.01 μm / 0.05 °C	0.01 μm / 0.05 °C
Deformation Force	—	—	up to 20 kN	up to 10 kN
Deformation Rate Strain Rate	—	—	0.01 mm/s to 200 mm/s 0.001 to 20.0 s ⁻¹	0.01 mm/s to 20 mm/s 0.001 to 2.0 s ⁻¹
True Strain	—	—	0.05 - 1.2	0.05 - 1.2
Deformation	—	—	Max. 7 mm	Max. 7 mm
Number of deformation steps	—	—	Unlimited	Unlimited
Min. pause between deformation steps	—	—	40 ms	40 ms

QUENCHING DILATOMETER | APPLICATIONS

Steel Phase Transformation

Phase transformations in steel are highly path dependent, reflecting the effects of earlier processing steps on subsequent phase composition. The transitions between different phases of steel are especially clear when measured by the DIL 805A Quenching Dilatometer, and the temperatures at which they occur are critical in the construction of the TTT and CCT diagrams. In this example, the first ramp rate heats the sample above its austenitic temperature, at which time it is quenched. The plot shows the start (Ar3) and finish (Ar1) of the phase transformation from austenite to ferrite. These two temperature points can then be fitted to a CCT diagram based on the quench rate.

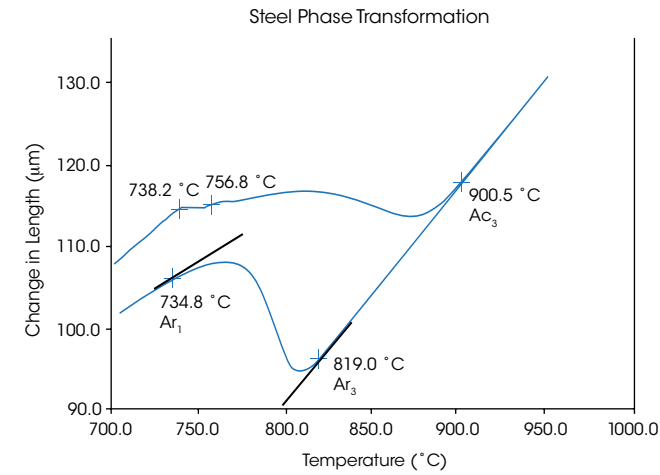

Continuous Cooling Transformation Diagram

As the name suggests, the CCT phase diagram represents the phase transformation of a material when it is cooled at various controlled rates. In the heat treatment of steel, the CCT diagram is used to predict the final crystalline structure of the processed steel. This crystalline structure determines the physical properties and suitability for the application in which the material will be used. The DIL 805A is the ideal tool to observe small dimensional changes under extreme conditions of controlled cooling. Software is available for the seamless preparation of TTT or CCT diagrams.

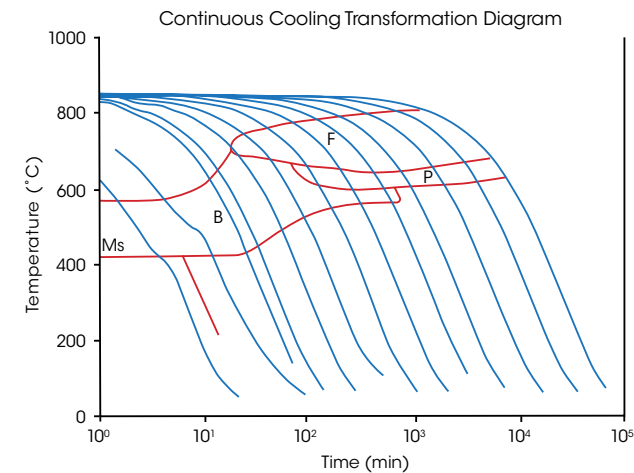

Force Deformation

The 805D add-on module can precisely control the strain-rate of a sample and measure the resultant force required to achieve this. In this high speed test run, a deformation rate of 10 mm/s is used for a maximum displacement of 5 mm (Strain 0.50). The force exerted by the hydraulic ram is closely monitored, and both data sets can be used to plot the true stress vs. true strain curve of the material.

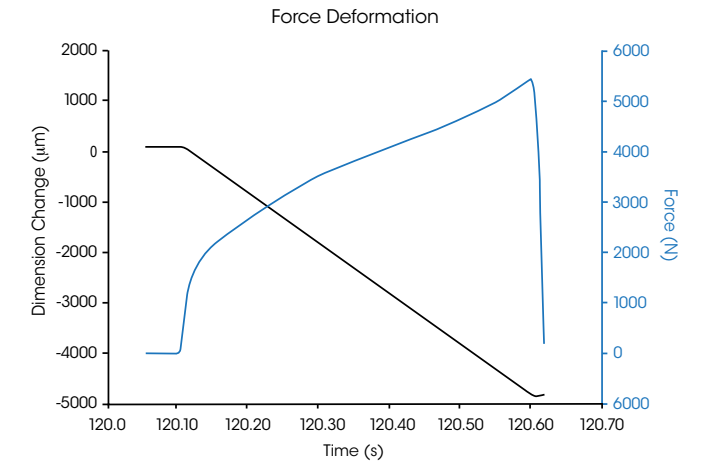

3-Step Deformation Test

Simulating metal processing techniques, and the phase transformations that take place upon quenching or heat treating, are important measurements to perform in order to accurately control the crystalline structure and its inherent physical properties. The DIL 805A/D is the ideal instrument for optimizing the quench rate after these multi-step deformations. In this example, after the initial heating and resultant thermal expansion, the parcel of steel is held isothermally and goes through a series of 3 deformation steps: an initial 1mm deformation over a 100 second time period; a second 1 mm deformation over a 10 second time period, and finally a seemingly instantaneous force applied for the final 1 mm deformation. After another 10 second dwell at the isothermal processing temperature, the material is quenched and the contraction and phase transformation is measured. Using this measured data, the manufacturer can streamline their processing for repeatable production of steel with the desired physical properties.

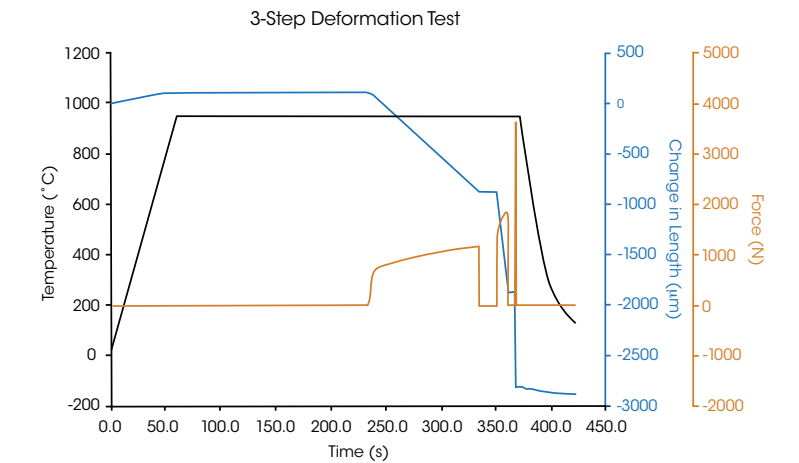

True Stress vs. True Strain Curves

This plot is the true stress vs. true strain curves, measured during the deformation steps in the above example. Please note that the "instantaneous" force pulse in the third deformation step was measured and can now be analyzed. With over 100,000 data points taken per second, the DIL 805A/D is a powerful tool that can further help engineers develop the mechanical aspects of the processing line.

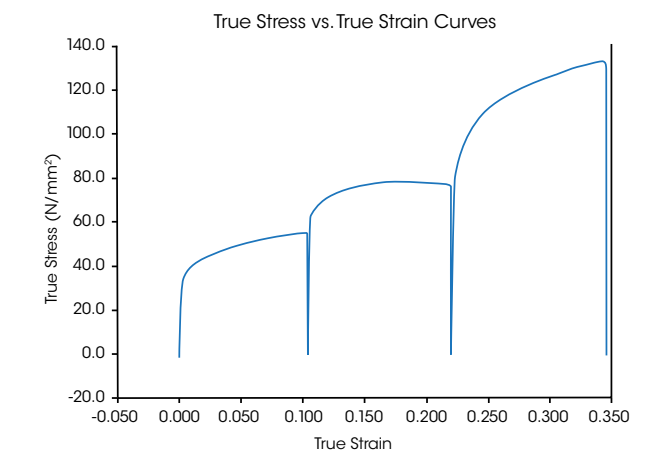



AMERICAS

- New Castle, DE USA
- Lindon, UT USA
- Wakefield, MA USA
- Eden Prairie, MN USA
- Chicago, IL USA
- Costa Mesa, CA USA
- Montreal, Canada
- Toronto, Canada
- Mexico City, Mexico
- São Paulo, Brazil

EUROPE

- Hüllhorst, Germany
- Bochum, Germany
- Eschborn, Germany
- Wetzlar, Germany
- Elstree, United Kingdom
- Brussels, Belgium
- Ettlen-Leur, Netherlands
- Paris, France
- Barcelona, Spain
- Milano, Italy
- Warsaw, Poland
- Prague, Czech Republic
- Solna, Sweden
- Copenhagen, Denmark

ASIA & AUSTRALIA

- Shanghai, China
- Beijing, China
- Tokyo, Japan
- Seoul, South Korea
- Taipei, Taiwan
- Guangzhou, China
- Petaling Jaya, Malaysia
- Singapore
- Bangalore, India
- Sydney, Australia



Waters
THE SCIENCE OF WHAT'S POSSIBLE.™

©2020 TA Instruments/Waters Corporation. L90047.001

TA Instruments

159 Lukens Drive
New Castle, DE 19720 U.S.A.
T: 1 302 427 4000
F: 1 302 427 4041
www.tainstruments.com

Waters Corporation

34 Maple Street
Milford, MA 01757 U.S.A.
T: 1 508 478 2000
F: 1 508 872 1990
www.waters.com