

# OLYMPUS®

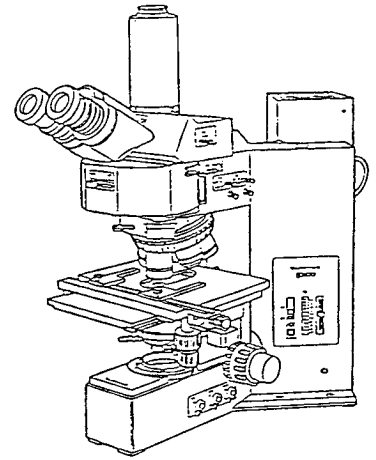

---

## INSTRUCTIONS BX60 SYSTEM MICROSCOPE

This instruction manual is for the Olympus System Microscope Model BX60. To ensure the safety, obtain optimum performance, and to familiarize yourself fully with the use of this microscope, we recommend that you study this manual thoroughly before operating the microscope. Retain this instruction manual in an easily accessible place near the work desk for future reference.



A X 7 0 7 0

# IMPORTANT

This unit features a UIS (universal infinit system) optical design, and should be used only with UIS eyepieces, objectives, and condensers. Less than optimum performance may result if inappropriate accessories are used.

BX60 is a versatile microscope which can be used both with transmitted light for use in the biological field and with reflected light for metallurgical research. Accordingly, this instruction manual contains:

- Separate outlines of the observation procedures when the microscope is used in biological or metallurgical research purposes.
- Explanation of the use of controls is divided into sections.
- The most important points of the various observation methods are explained.

For reflected light fluorescence microscopy also refer to the manual pertaining to the reflected light fluorescence attachment BX-FLA.

## Safety Precautions

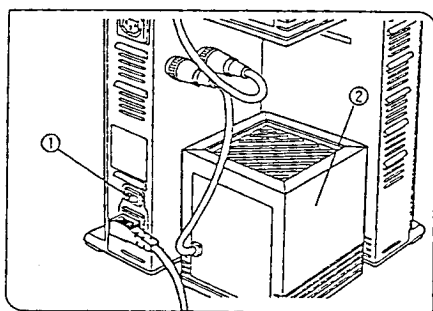





1. Install the microscope on a sturdy, level table or bench. The air vents on the underside of the base should never be blocked such as by placing the microscope on a flexible surface, as this could result in overheating and cause a fire.
2. The surfaces of the lamp housing will become extremely hot during operation. When installing the microscope, make sure to allow ample free space around and in particular above and below the lamp housing.
3. When installing the microscope, route the power cord away from the lamp housing. Should the power cord come in contact with the hot lamp housing, the power cord could melt and cause electric shock.
4. To avoid potential shock hazards and burns, first set the main switch ① to "O" (OFF) and then disconnect the power cord from the wall outlet before replacing the bulb and fuses. Whenever you replace the bulb during use or right after use, allow the lamp housing ② and bulb to cool before touching.

Designated bulb	12V, 100W HAL-L (PHILIPS 7724)
Designated fuse	T5A(H) 250V (LITTLEFUSE 215005)

5. Always use the power cord provided by Olympus. If no power cord is provided, please select the proper power cord by referring to the section "PROPER SELECTION OF THE POWER SUPPLY CORD" at the end of this instruction manual. If the proper power cord is not used, product safety and performance cannot be guaranteed.
6. Always ensure that the ground terminal of the microscope and that of the wall outlet are properly connected. If the equipment is not grounded, Olympus can no longer warrant the electrical safety and performance of the equipment.
7. Never insert metal objects, etc. into the air vents of the microscope frame as this could result in electrical shock and personal injury.

**Safety Symbols**

The following symbols are found on the microscope. Study the meaning of the symbols, and always use the equipment in the safest possible manner.

Symbol	Explanation
	Indicates that the surface becomes hot, and should not be touched with bare hands.
	Before use, carefully read the instruction manual. Improper handling could result in personal injury to the user and/or damage to the equipment.
	Indicates a potential fire hazard; when replacing fuses, be sure replacement fuse is of the specified rating.
	Indicates that the main switch is ON.
	Indicates that the main switch is OFF.

**Warnings**

Warning engravings are placed at parts where special precaution is required when handling and using the microscope. Always heed the warnings.

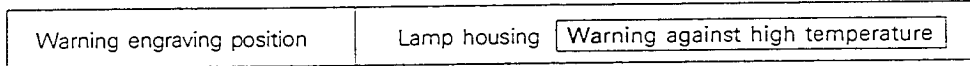

**1 Getting Ready**

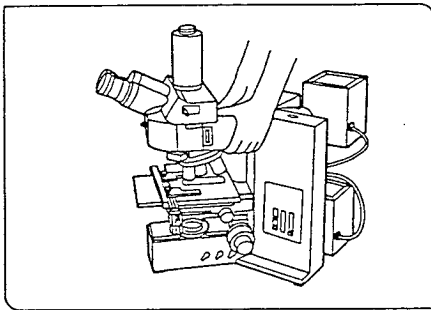

1. A microscope is a precision instrument. Handle it with care and avoid subjecting it to sudden or severe impact.
2. Do not use the microscope where it is subjected to direct sunlight, high temperature and humidity, dust, or vibrations. (For operating conditions, refer to Section 7, SPECIFICATIONS on page 37.)
3. When moving the microscope, carefully carry it with both hands by grasping the arm as shown in the figure on the left. (Weight: Approximately 18 kg (40 lb.)  
★ Damage to the microscope may occur if you grasp it by the stage, coarse adjustment knob, or binocular section of the observation tube, etc.
4. The BX60 can be used with one more intermediate attachment (all attachments with the exception of the U-DO dual-viewing attachment and the U-MDO10 multi-viewing attachment).

## 2 Maintenance and Storage

1. Clean all glass components by wiping gently with gauze. To remove fingerprints or oil smudges, wipe with gauze slightly moistened with xylene or a mixture of ether (70%) and alcohol (30%).
  - ⚠ Since both ether and alcohol are highly flammable, be careful to keep these chemicals away from open fire and potential sources of electrical sparks, such as when main switches are switched from "I" (ON) to "O" (OFF) and vice versa.
2. Do not attempt to use organic solvents to clean the non-optical components of the microscope (especially plastic parts). To clean these, use a lint-free, soft cloth lightly moistened with a diluted neutral detergent.
3. Do not disassemble any part of the microscope as this could result in malfunctions or reduced performance.
4. When not using the microscope, keep it covered with the provided dust cover.

## 3 Caution

If the equipment is used in a manner not specified in this manual, the safety of the user may be imperiled. In addition, the equipment may also be damaged. Always use the equipment as outlined in this instruction manual.

<b>1</b>	<b>NOMENCLATURE</b>	<b>1</b>
<b>2</b>	<b>ASSEMBLY</b>	<b>2</b>
	2-1 Assembly Diagram .....	2
	2-2 Detailed Assembly Procedure .....	3
<b>3</b>	<b>CONTROLS</b>	<b>10</b>
<b>4</b>	<b>SUMMARY OF OBSERVATION PROCEDURES</b>	<b>13</b>
	Biological Microscopy .....	13
	Metallurgical Microscopy .....	15
<b>5</b>	<b>USING THE CONTROLS</b>	<b>17</b>
	5-1 Base .....	17
	5-2 Brightfield/Darkfield Vertical Illuminator .....	20
	5-3 Stage .....	22
	5-4 Observation Tube .....	25
	5-5 Condenser .....	27
	5-6 Focusing Adjustment Knobs .....	29
	5-7 Immersion Objectives (for biological purposes only) .....	30
	5-8 Photomicrography .....	30
<b>6</b>	<b>OBSERVATION METHODS</b>	<b>32</b>
	6-1 Transmitted Light Brightfield Observation .....	32
	6-2 Reflected Light Brightfield/Darkfield Observation .....	32
	6-3 Reflected Light Nomarski Differential Interference Contrast Observation .....	33
	6-4 Reflected Light Simple Polarized Light Observation .....	34
	6-5 Reflected Light Fluorescence Observation .....	35
<b>7</b>	<b>SPECIFICATIONS</b>	<b>36</b>
<b>8</b>	<b>OPTICAL CHARACTERISTICS</b>	<b>38</b>
<b>9</b>	<b>TROUBLESHOOTING GUIDE</b>	<b>40</b>
	■ PROPER SELECTION OF THE POWER SUPPLY CORD .....	43

# NOMENCLATURE

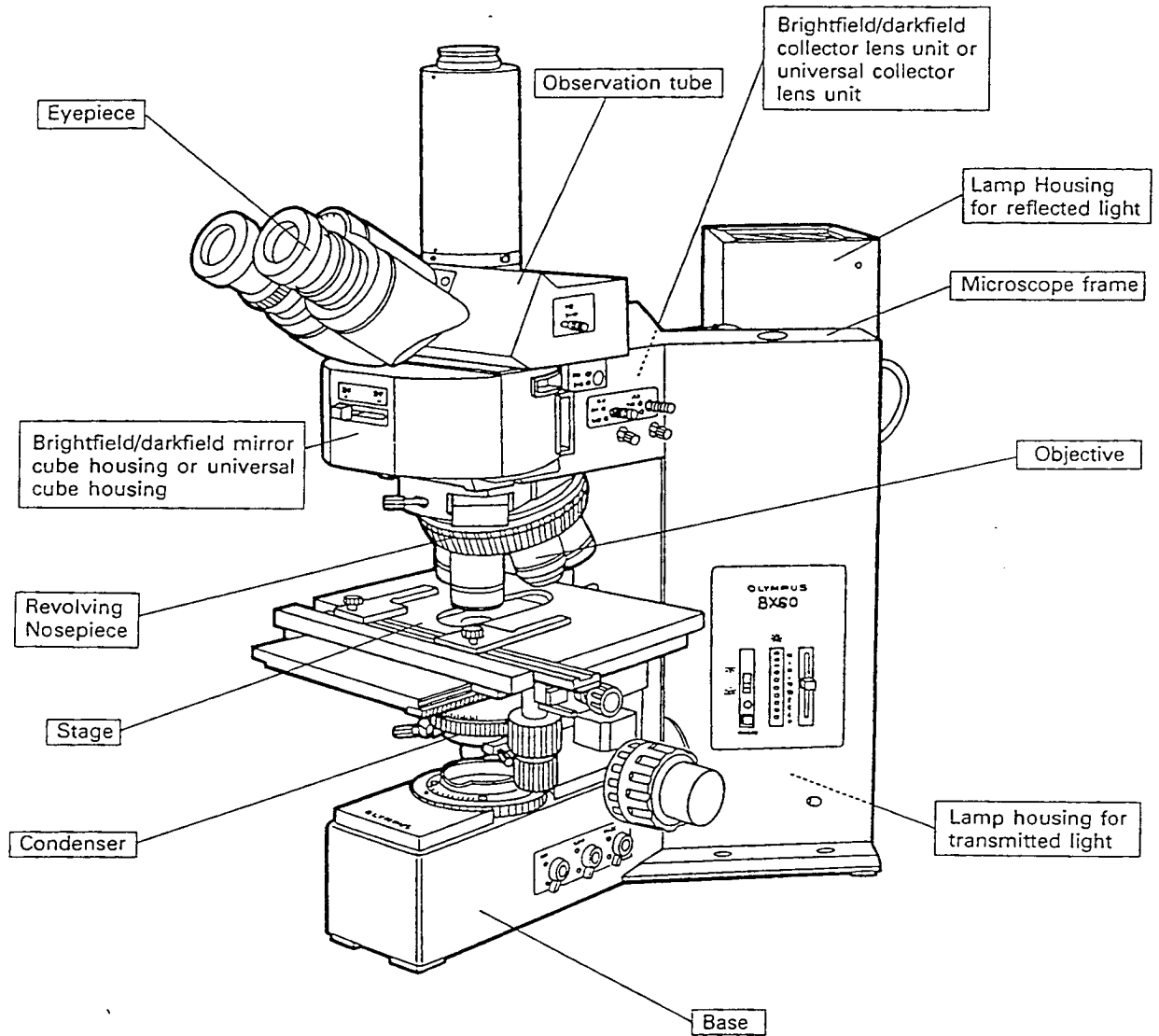

## 2-1 Assembly Diagram

The diagram below shows how to assemble the various components. The numbers indicate the order of assembly.  
 ★ When assembling the microscope, make sure that all parts are free of dust and dirt, and avoid scratching any parts or touching glass surfaces.

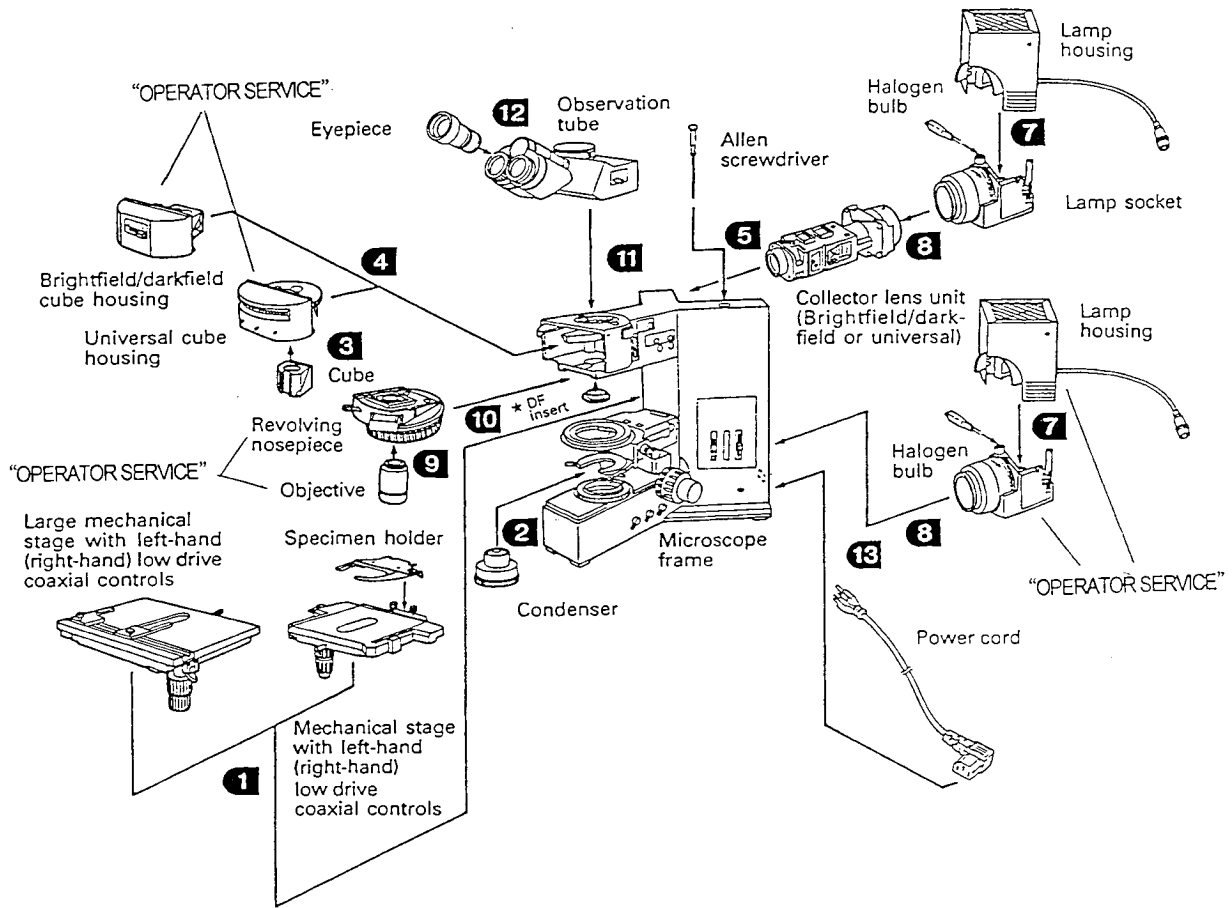

★ The DF (darkfield) insert is attached when the microscope is used for reflected light microscopy. Be sure to remove the insert when the microscope is used for transmitted light microscopy.

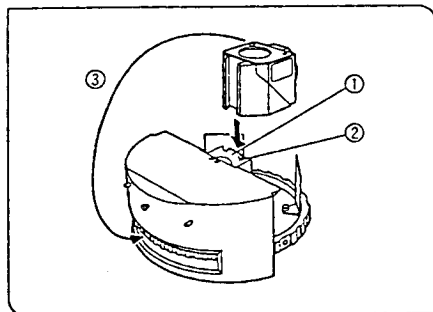

Fig. 3

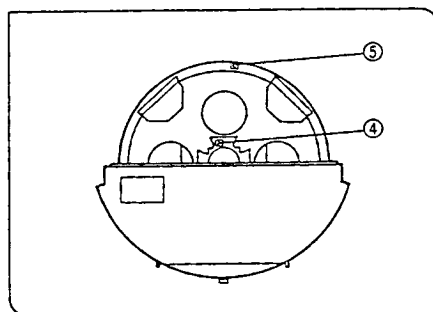

Fig. 4

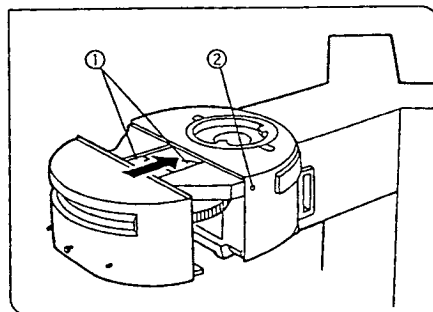

Fig. 5

### 3 Mounting the Cubes (Universal Cube Housing)

(Figs. 3, 4)

#### "OPERATOR SERVICE"

⊙ The following procedure does not apply to the brightfield/darkfield mirror cube housing.

★ Loosen the screw that secures the cube housing to the frame with the provided Allen screwdriver. It is located in the hole at the right side of the arm.

1. Invert the cube housing so that the cube dovetail mounts on the turret **①** point upward.

(Dummy plates are mounted in three of the four cube positions. When you wish to use only one cube, mount it in the empty position. When using two or more cubes, loosen the clamping screw **②** with the Allen screwdriver and remove the dummy plate(s) by pulling in the direction indicated by the arrow, and then mount the actual cube(s) in its place.)

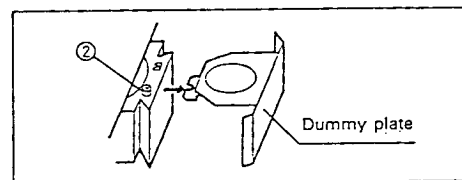

2. Hold the cube to be mounted with its index side facing upward and slide it all the way onto the dovetail mount. Next, be sure to tighten the cube clamping screw **②** immediately. (Tighten all four cube clamping screws.)
3. Remove the cube's magnetic index sticker **③**\* and affix it to the corresponding turret position. (Fig. 3)

\*Use a sharp object such as the tip of a ballpoint pen or mechanical pencil to lift the cube's magnetic index sticker.

★ The cube indices A, B, C, D **④** on the dovetail mount correspond to the turret's A, B, C, D indices **⑤**. Make sure to match the attached cube correctly with the position of the removed magnetic index sticker (WU, NU, etc.) on the turret. (Fig. 4)

#### "OPERATOR SERVICE"

### 4 Mounting the Cube Housing

(Fig. 5)

1. Align the cube housing dovetail **①** with the dovetail **①** at the front of the arm and fully slide it into the arm.
2. Insert the Allen screwdriver through the hole **②** on the right side of the arm, then securely tighten the cube housing clamping screw.

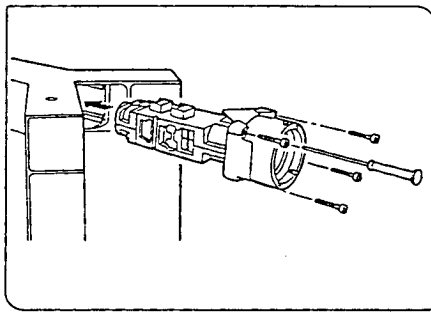

Fig. 6

## 5 Mounting the Collector Lens Unit (Fig. 6)

1. Gently insert the collector lens unit as far as it will go into the opening located at the rear of the arm.
2. Insert the provided screws in the four screw holes and tighten securely with the Allen screwdriver.

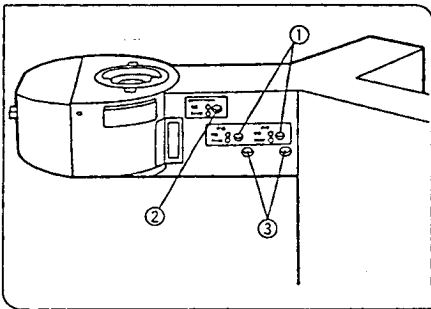

Fig. 7

## 6 Attaching the Field Iris Diaphragm and Aperture Iris Diaphragm Knobs (Fig. 7)

	Field iris diaphragm knob, aperture iris diaphragm knob, pinhole knob
	Field iris diaphragm centering knob Aperture iris diaphragm centering knob
	Shutter knob (only used with the U-URBL universal vertical illuminator lens unit)

1. Insert the provided field iris diaphragm and aperture iris diaphragm knobs through the holes ① on the right side of the arm, then screw in the knobs until tight.
  - Ⓞ When using the U-URBL universal vertical illuminator lens unit, the shutter knob should also be attached in the same manner. Insert the shutter knob through the hole ② on the right side of the arm, then screw in the knob until tight.
2. Insert the provided field iris diaphragm and aperture iris diaphragm centering knobs through the holes ③ on both sides of the arm, then screw in the knobs until tight.
  - ★ Note that the centering knobs should be screwed in at an angle from below.
3. Insert the provided pinhole knob through the hole on the left side of the arm, then screw in the knob until tight (U-RLBL only).

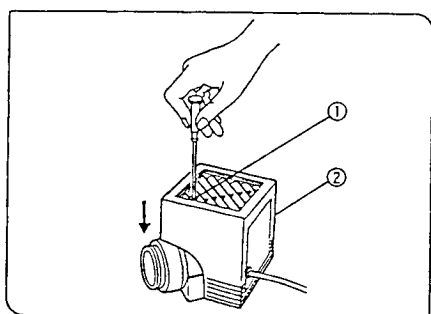

Fig. 8

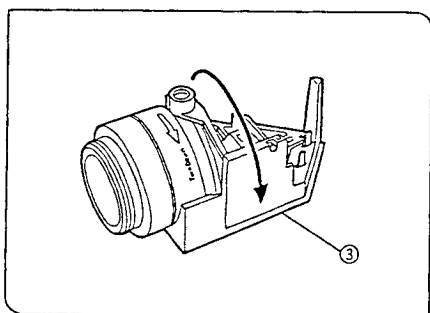

Fig. 9

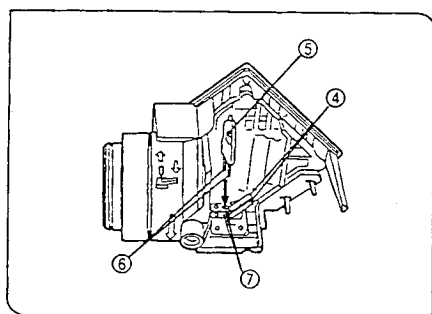

Fig. 10

7

“OPERATOR SERVICE”

Installing the Halogen Bulb  
(for both Transmitted/Reflected Light)

“OPERATOR SERVICE”

- Use only a designated 12V, 100W/HAAL-L halogen bulb (PHILIPS 7724).
- 1. Fully loosen the lamp housing clamping screw ① on top of the lamp housing cover with the Allen screwdriver.
- 2. Lift the lamp housing cover ② upward to remove it. (Fig. 8)
- 3. Turn the lamp socket ③ 90° in the direction indicated by the arrow.
- 4. Holding the bulb ⑤ with gloves or a piece of gauze, depress the bulb clamping levers ④ and insert the bulb pins ⑥ fully into the pin holes ⑦. Gently release the bulb clamping levers ④ to their original position to secure the bulb. (Fig. 10)

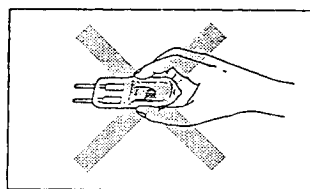

★ To prevent reduced bulb life or cracking, do not touch the bulb with bare hands. If fingerprints are accidentally left on the bulb, wipe the bulb with a soft cloth.

- 5. Slide the lamp housing cover onto the housing base from above. Tighten the clamping screw ① while pressing downward on the cover. (Fig. 8)

**⚠** Bulb Replacement During Use or Right After Use

The bulb and the lamp housing surfaces and vicinity will be extremely hot during use and right after use.

Set the main switch to “O” (OFF) and disconnect the power cord from the wall outlet. Then allow the old bulb, lamp housing and vicinity to cool before replacing the bulb with a new of the designated type.

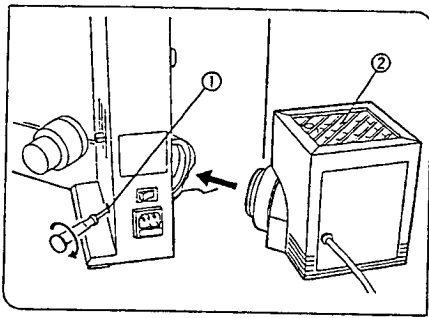

Fig. 11

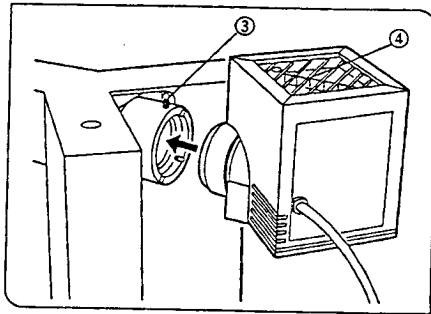

Fig. 12

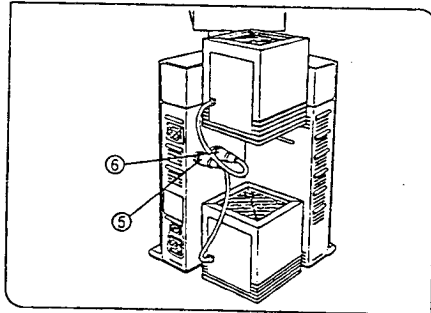

Fig. 13

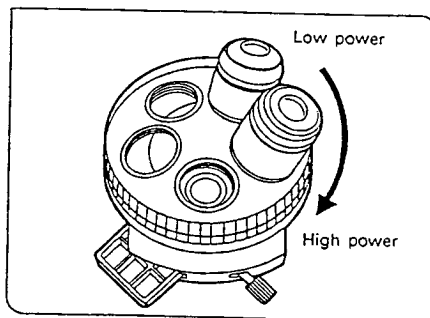

Fig. 14

## 8 Attaching the Lamp Housing to the Microscope

(Figs. 11,12,13)

"OPERATOR SERVICE"

### Transmitted Light Lamp Housing

1. Using the Allen screwdriver, fully loosen the lamp housing clamping screw ① on the microscope.
  2. Insert the lamp housing collector unit into the opening in the microscope frame until it touches the lamp housing mounting collar on the back of the base (lower part), then tighten the clamping screw ①. (Fig. 11)
- ⚠ Attach the lamp housing horizontally with the radiating fin ② upward and make sure to allow ample free space above, below and behind the lamp housing (Fig. 11)

### Reflected Light Lamp Housing

1. Using the Allen screwdriver, fully loosen the lamp housing clamping screw ③ on the reflected light port on the microscope. (Fig. 12)
  2. Insert the lamp housing collector unit into the lamp port until it touches the lamp housing mounting collar on the back of the base (upper part), then tighten the clamping screw ③. (Fig. 12)
- ⚠ Attach the lamp housing horizontally with the radiating fin ④ upward and make sure to allow ample free space above, below and behind the lamp housing.
3. Insert the cord plug from the transmitted light lamp housing securely into the power outlet ⑤. Insert the cord plug from the reflected light lamp housing securely into the power outlet ⑥. (Fig. 13)

"OPERATOR SERVICE"

## 9 Mounting the Objectives

(Fig. 14)

- ⊙ For reflected light observation, make sure to mount metallurgical UIS objectives.
- Mount the objectives on the revolving nosepiece in such a manner that the magnification increases from low to higher powers in a clockwise direction. (Fig. 14)

## "OPERATOR SERVICE"

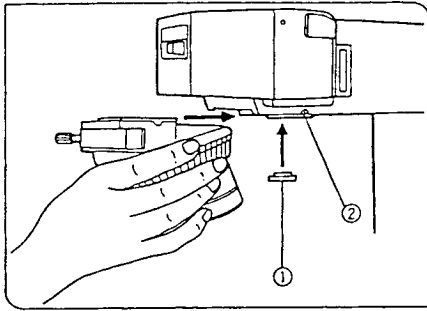

Fig. 15

**10** Mounting the Revolving Nosepiece (Fig. 15)

★ When used for metallurgical observation:

Mount the DF insert ①. The insert will be held in place by the magnet on the underside of the arm.

1. Turn the coarse adjustment knob to lower the stage all the way.
2. Using the Allen screwdriver, loosen the nosepiece clamping screw ② on the microscope.
3. Carefully slide the nosepiece along the dovetail, in the direction of the arrow, all the way in.
4. Clamp the nosepiece by tightening the nosepiece clamping screw.

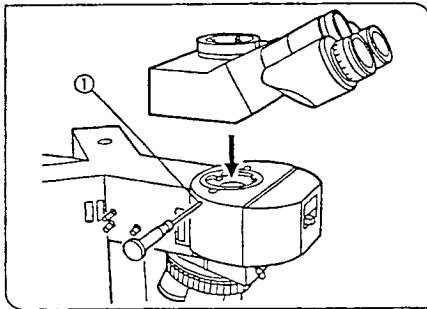

Fig. 16

**11** Mounting the Observation Tube (Fig. 16)

1. Using the Allen screwdriver, loosen the observation tube clamping screw ①.
  2. Insert the circular dovetail mount at the bottom of the observation tube into the opening on the microscope frame, positioning the observation tube to point the binocular eyepieces towards the front. Clamp the observation tube by tightening the clamping screw.
- ⊙ If the direction of stage movement and the direction of image movement differs during observations, loosen the stage clamping screw slightly and adjust the stage by rotating it, while observing the image.

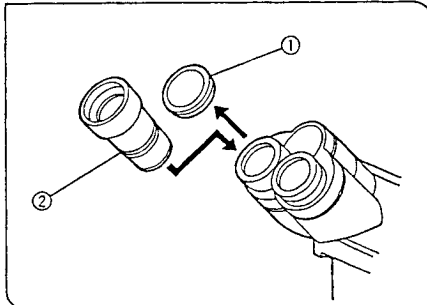

Fig. 17

**12** Mounting the Eyepieces (Figs. 17, 18)

1. Remove the eyepiece dust caps ①.
2. Insert the eyepieces ② into the eyepiece sleeves as far as they will go. (Fig. 17)

When Using the Trinocular Observation Tube (U-TR30) or the Super-widefield Trinocular Observation Tube (U-SWTR)

When using a finder eyepiece or an eyepiece with micrometer adjustment, insert this eyepiece into the right-hand eyepiece sleeve. When doing so, make sure that the eyepiece positioning pin ③ fits into the notch ④ on the eyepiece sleeve. (Fig. 18)

- ⊙ The super-widefield trinocular observation tube is equipped with a positioning notch on both eyepiece sleeves. Make sure that the positioning pin on both eyepieces fits into the respective notch.

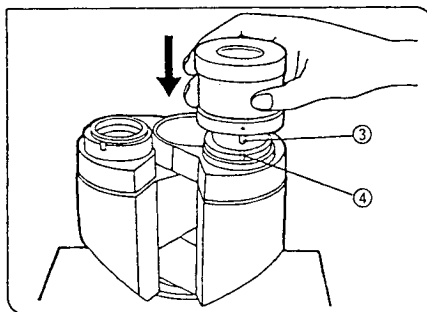

Fig. 18

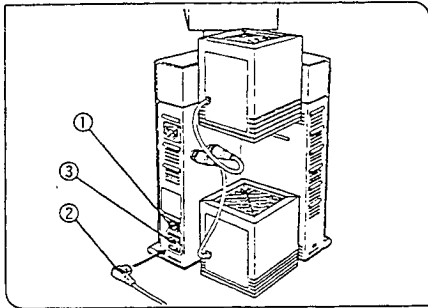

Fig. 19

### 13 Connecting the Power Cord

(Fig. 19)

- ⚠ Cables and cords are vulnerable when bent or twisted. Never subject them to excessive force.
- ⚠ Make sure that the main switch ① is set to "O" (OFF) before connecting cords and cables. (Fig. 19)
- ⚠ Always use the power cord provided by Olympus. If no power cord is provided, please select the proper power cord by referring to the section "PROPER SELECTION OF THE POWER SUPPLY CORD" at the end of this instruction manual.

1. Connect the power cord plug ② to the AC receptacle ③. (Fig. 19)
2. Plug the power cord plug into a wall outlet.

- ⚠ Connect the power cord correctly and ensure that the ground terminal of the power supply and that of the wall outlet are properly connected. If the equipment is not grounded, Olympus can no longer warrant the electrical safety and performance of the equipment.

- ⚠ When installing the power cord, route the power cord away from the lamp housing. Should the power cord come in contact with the hot lamp housing, the power cord could melt and cause electric shock.

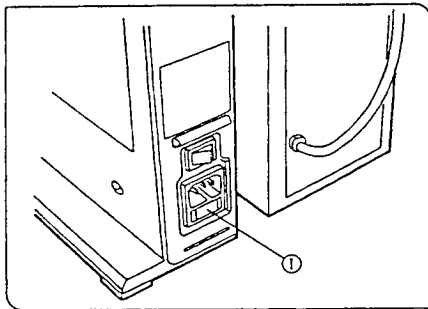

Fig. 20

### 14 Fuse Replacement

(Figs. 20, 21)

- ⊙ Before replacing fuses, set the main switch to "O" (OFF) and unplug the power cord. (The power cord should be unplugged from the AC receptacle to allow removal of the fuse holder.)

1. Remove the fuse holder ① by inserting the tip of a flat-bladed screwdriver to squeeze at the left or right side of the fuse holder and pulling outward. (Fig. 20)
2. Replace both fuses ② with new ones. (Fig. 21)

- ★ Use only specified fuses. Use of improper fuse type could result in a fire.

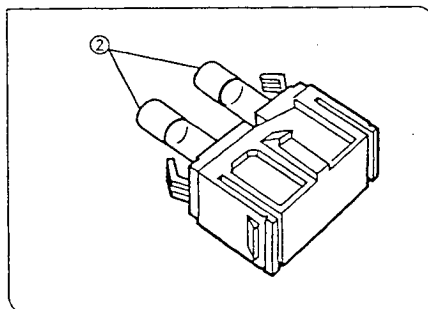
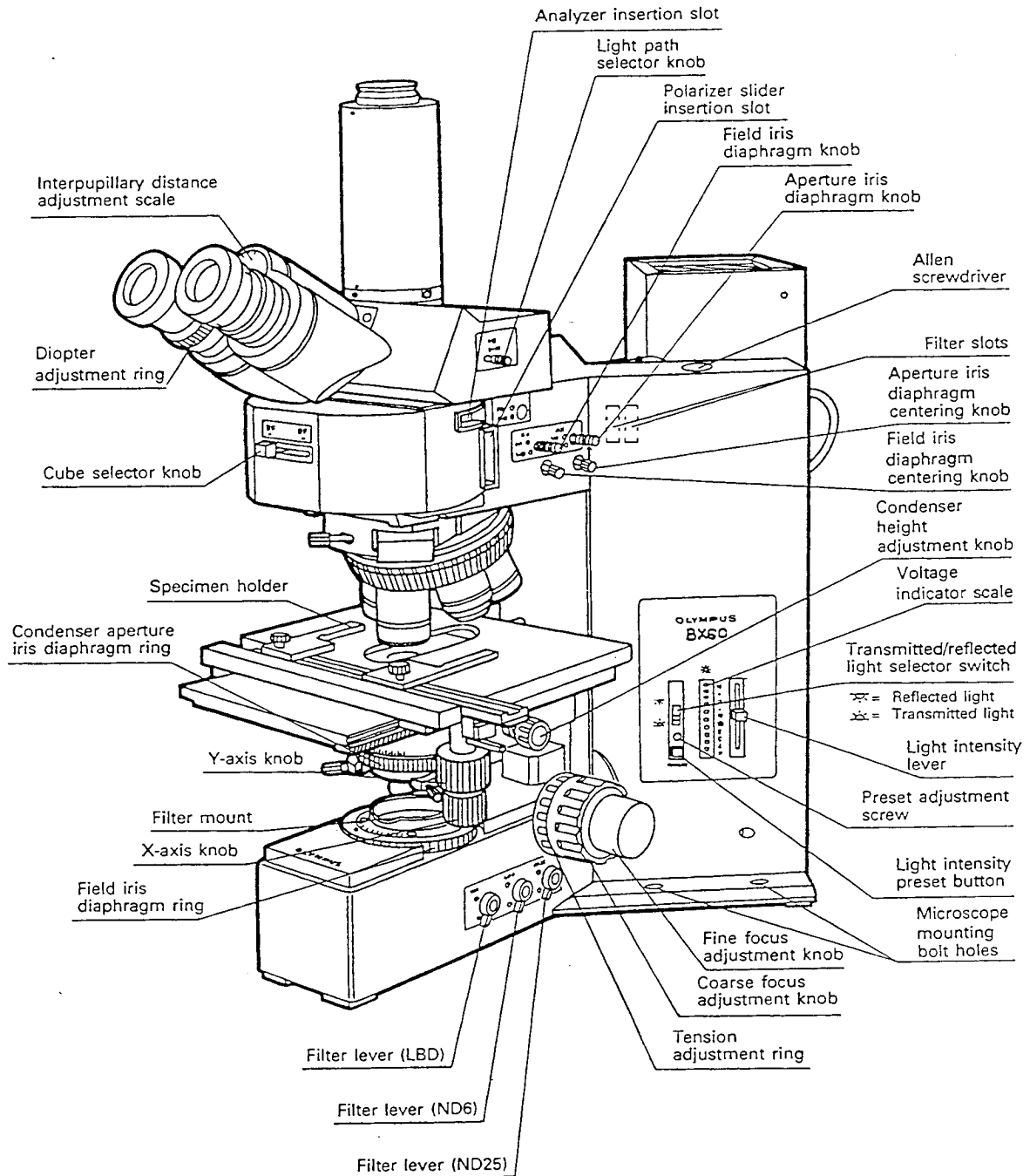

Fig. 21

Applicable fuse:  T5A(H) 250V, 2 fuses  
(LITTLEFUSE 215005)

# 3 CONTROLS



© The above illustration shows the microscope with the U-RLBC mirror cube housing for the brightfield/darkfield vertical illuminator. In the case of the U-URBC cube housing for the universal vertical illuminator, the cube selector knob is replaced by a turret.

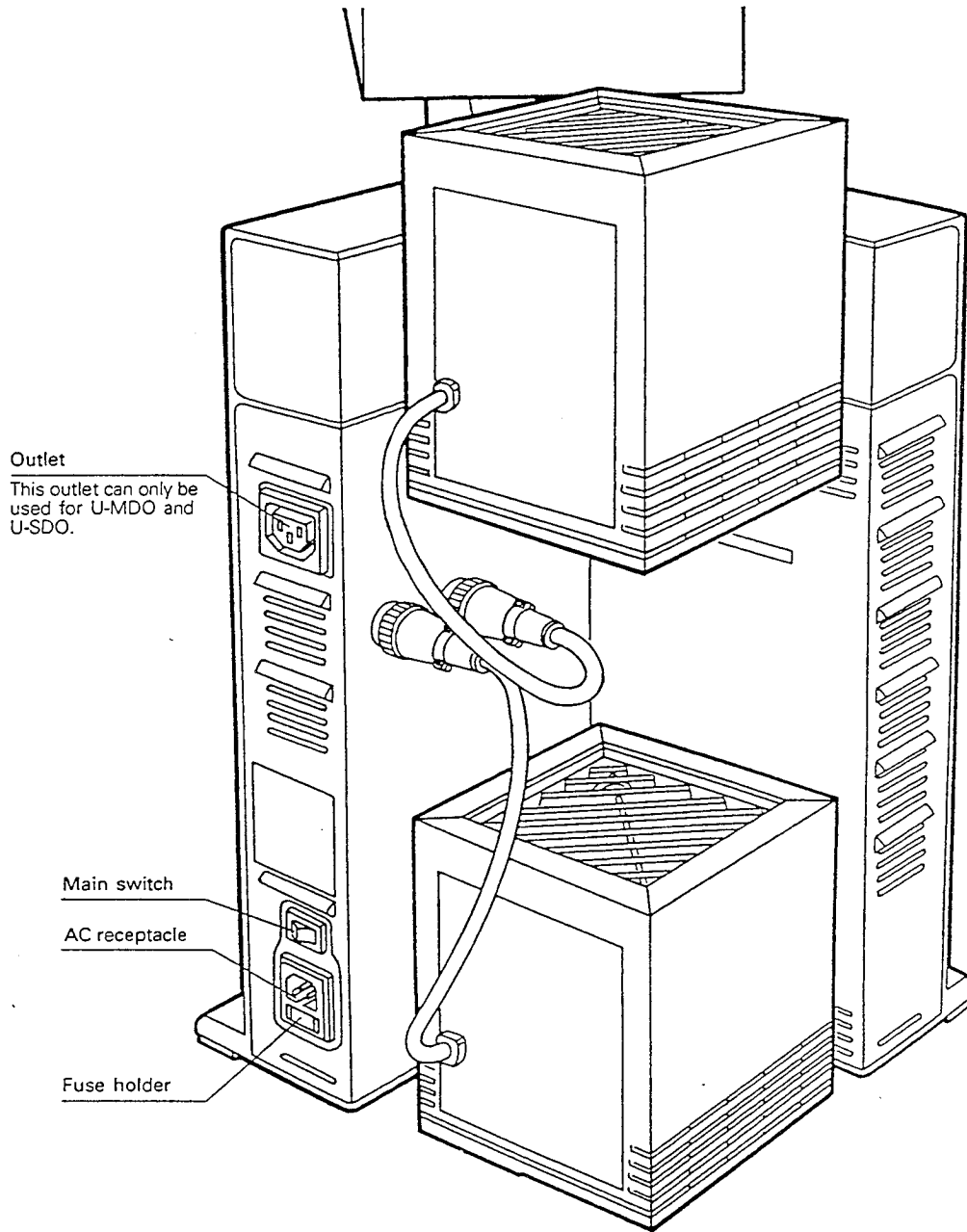

Brightfield/Darkfield Vertical Illuminator Attachment (U-RLBC/U-RLBL)

Mirror Cube Housing (U-RLBC)

Collector Lens Unit (U-RLBL)

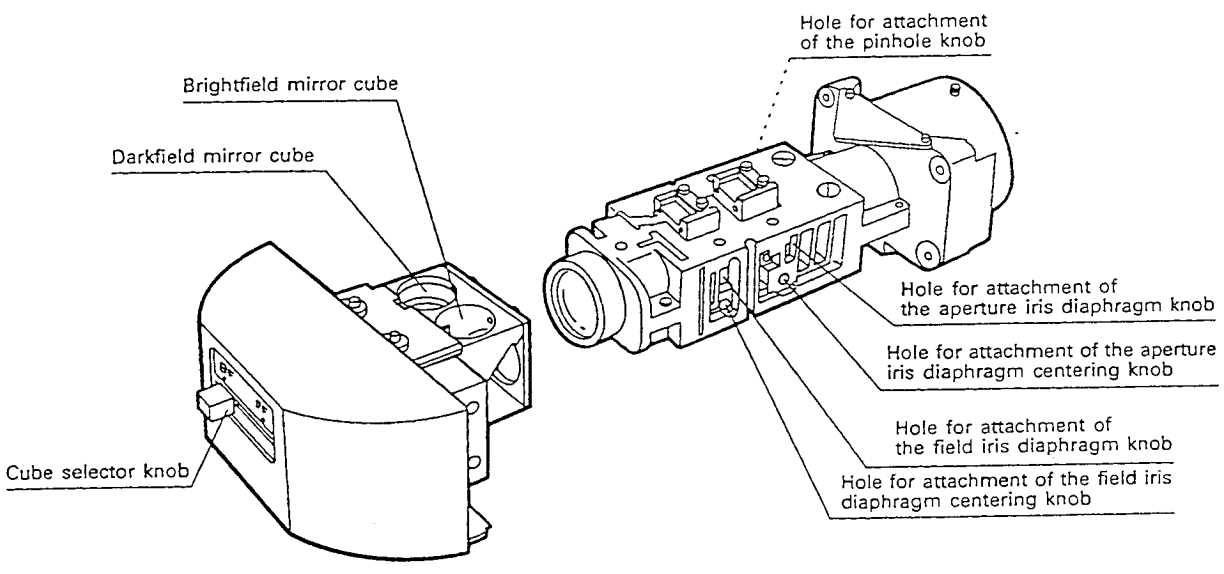

Universal Vertical Illuminator Attachment (U-URBC/U-URBL)

○ Refer to Section 6-5, Reflected Light Fluorescence Observation, for operation details.

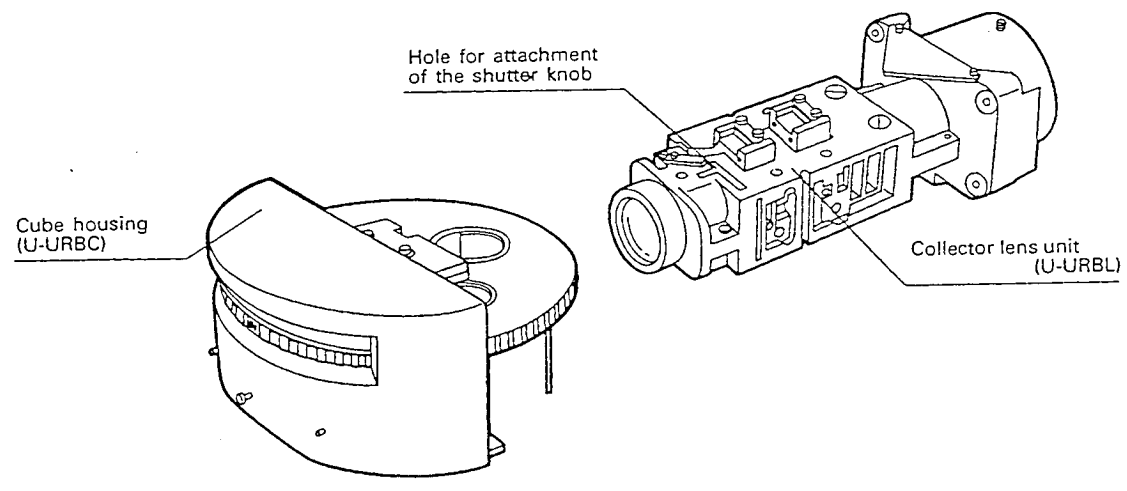

# 4 SUMMARY OF OBSERVATION PROCEDURES

## Biological Microscopy

The following section outlines the operational procedures when the microscope is used for normal biological microscopy (transmitted light brightfield observation).

★ UIS objectives for biological microscopy should be used. Using the universal cube housing, rotate the cube turret to an empty position. Using the mirror cube housing, slide the cube selector cube to the DF position.

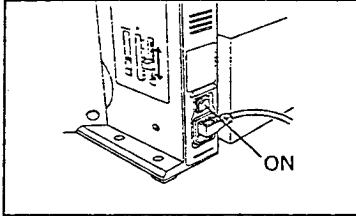

1. Press the transmitted/reflected light selector switch to select the transmitted light mode. Press the main switch to "I" (ON) and adjust the light intensity with the light intensity lever. (At this point, leave the light intensity preset button OFF.) (Page 17)

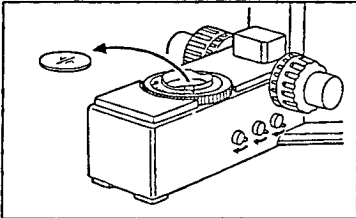

2. Disengage all filters from the light path. (Pages 17, 18)
  - a. Accessory filter cassette
  - b. Filters built into the base

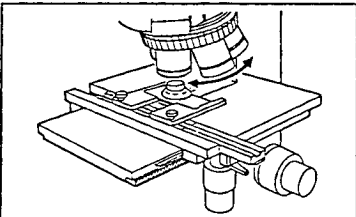

3. Turn the revolving nosepiece to engage the 10X objective. Make sure the revolving nosepiece clicks into position.

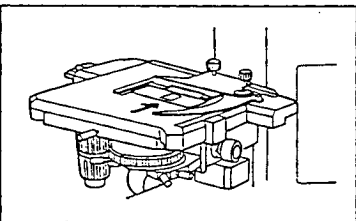

4. Place a specimen on the stage. (Page 22)

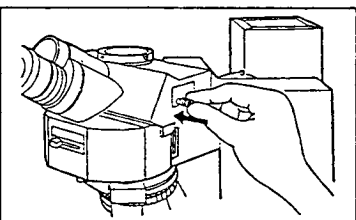

### Using a Trinocular Observation Tube

5. Push the observation tube's light path selector knob to "binocular eyepiece 100%" (the pushed-in position). (Page 26)

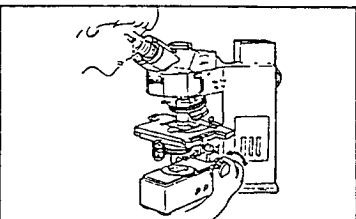

6. Looking through the right eyepiece with your right eye, turn the coarse adjustment knob to bring the specimen into focus. After obtaining approximate focus, use the fine adjustment knob to make final adjustments. (Page 29)

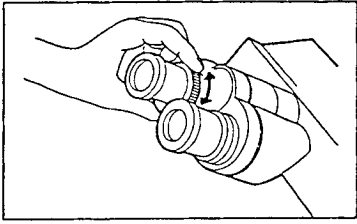

7. Looking through the left eyepiece with your left eye, turn the diopter adjustment ring to focus on the specimen. (Page 25)

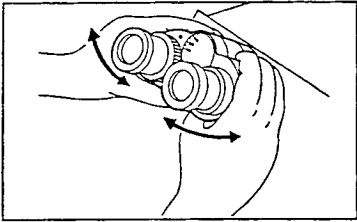

8. Adjust the interpupillary distance of the eyepieces. (Page 25)

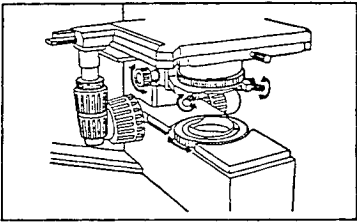

9. Adjust condenser centering and focusing. (Page 27)

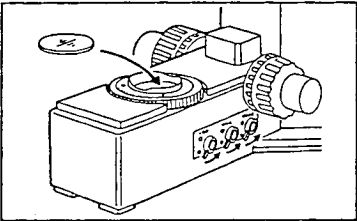

10. Engage the objective to be used and readjust the light intensity to the desired level for observation, then readjust the focus.  
11. Engage your choice of filters into the light path. (Pages 17, 18, 19)  
a. Accessory filter cassette  
b. Filters built into the base

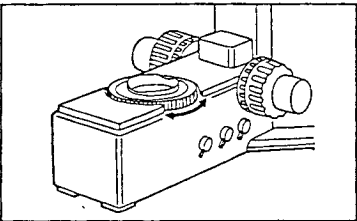

12. Adjust the field iris diaphragm. (Page 27)

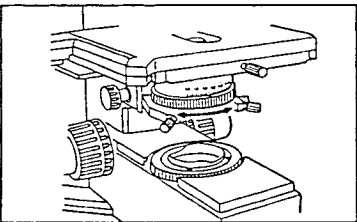

13. Adjust the aperture iris diaphragm. (Page 28)

## Metallurgical Microscopy

The following section outlines the operational procedures when the microscope is used for normal metallurgical microscopy (reflected light brightfield/darkfield observation) with the brightfield/darkfield vertical illuminator. In the case of the universal vertical illuminator, the cube selector knob is replaced by a turret.

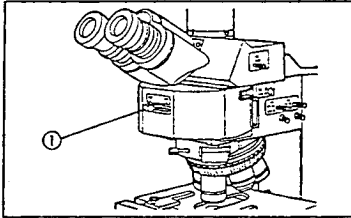

1. Select the cube according to the observation purpose. Set the cube selector knob ① to BF.

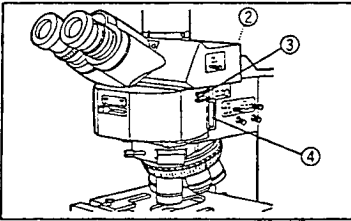

2. Disengage the filter sliders ② (left side of arm), analyzer slider ③, and polarizer slider ④ from the light path. (Pages 21, 33)

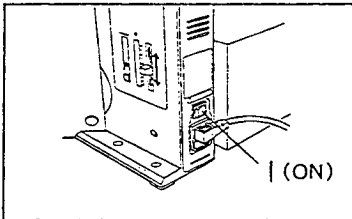

3. Press the transmitted/reflected light selector switch to select the reflected light mode. Press the main switch to "I" (ON) and adjust the light intensity with the light intensity lever. (At this point, leave the light intensity preset button OFF.) (Page 17)

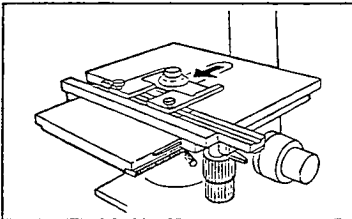

4. Place a specimen on the stage. (Pages 22, 23)

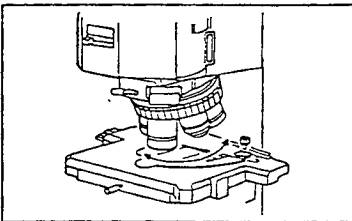

5. Turn the revolving nosepiece to engage the 10X objective. Bring the specimen into focus.

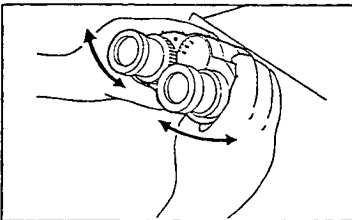

6. Adjust the interpupillary distance of the eyepieces. (Page 25)

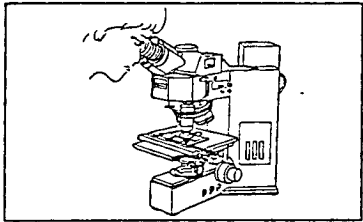

7. Looking through the right eyepiece with your right eye, turn the coarse adjustment knob to bring the specimen into focus. After obtaining approximate focus, use the fine adjustment knob to make final focus adjustments. (Page 29)

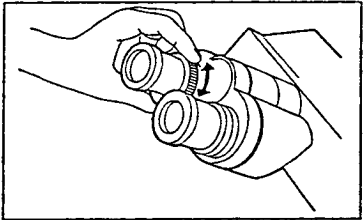

8. Looking through the left eyepiece with your left eye, turn the diopter adjustment ring to focus on the specimen. (Page 25)

9. Confirm that the illumination is adequate for the observation purpose. (Page 32)

	Cube index	Field iris diaphragm	Aperture iris diaphragm	Glare shielding ND
Reflected light brightfield	BF	Adjust as necessary		IN
Reflected light darkfield	DF	Open		

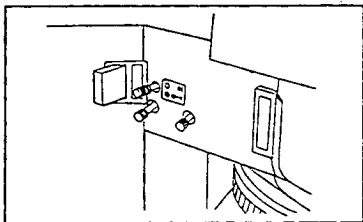

10. Engage the required filter. (Page 21)

11. Engage the objective to be used for observation, then readjust the focus and adjust the light intensity to a suitable level for observation.

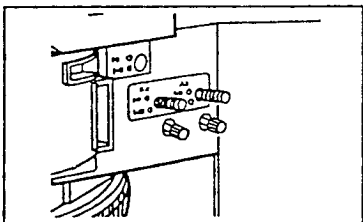

12. In case of reflected light brightfield observation, select the best field and aperture iris diaphragm settings in accordance with the objective and specimen. (Pages 20, 21)

# 5 USING THE CONTROLS

## 5-1 Base

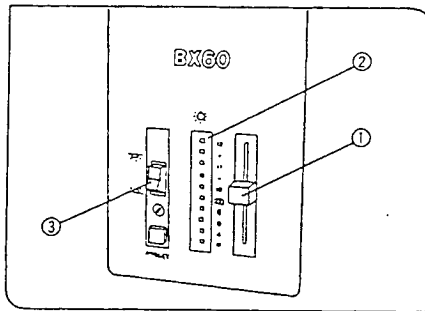



Fig. 22

### 1 Voltage Indicator (Fig. 22)

1. Sliding the light intensity lever ① upward increases the voltage, making illumination brighter.
  2. The numerals to the right of the voltage indicator LEDs ② indicate the voltage.
- ☉ For photomicrography, the voltage should be approximately at the level indicated by the camera symbol (  ).

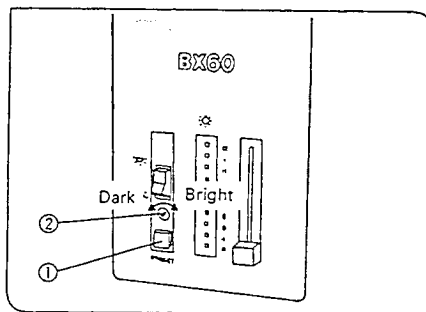

Fig. 23

### 2 Using the Transmitted/Reflected Light Selector Switch (Fig. 22)

1. Press the transmitted/reflected light selector switch ③ to select transmitted light illumination or reflected light illumination.

☉ : Reflected light

☉ : Transmitted light

### 3 Engaging the Light Preset Button (Fig. 23)

The light preset button ① makes it possible to set the light intensity to a preselected level regardless of the position of the light intensity lever.

1. Push the light preset button ① to the ON position. (The button lights when it is on ON.)
  2. Using a small screwdriver, turn the preset adjustment screw ② to obtain the required light intensity. Turning the screw clockwise increases brightness.
  3. Switch the light preset button OFF and brightness returns to the level set by the light intensity lever.
- ★ Moving the light intensity lever does not affect brightness while the light preset is ON.

#### Using the Light Preset Button

- ☉ The light preset button allows you to temporarily adjust brightness to a preset level for applications such as photomicrography, making it unnecessary to manually adjust the brightness each time you take a photograph. Before shipment from the factory, the preset level is set to an intensity suggested for photomicrography.
- ☉ The light preset button is also useful when using two different objectives alternately, helping you to avoid manually adjusting the brightness each time you change magnification.

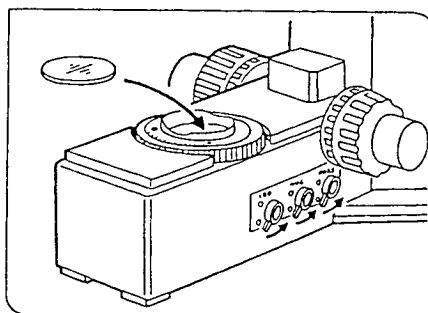

Fig. 24

### 4 Use of Accessory Filters (for Transmitted Light) (Figs. 24, 25, 26, 27, 28, 29)

#### Accessory Filter (Fig. 24)

You can place one 45 mm diameter filter in the filter holder on the light exit at the base of the microscope. If you need to use two or more filters at once, use a filter cassette.

- ★ When using a filter cassette, you can additionally use a single filter with a thickness of less than 3 mm over the light exit glass.

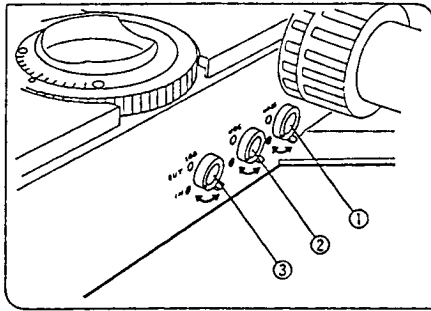

Fig. 25

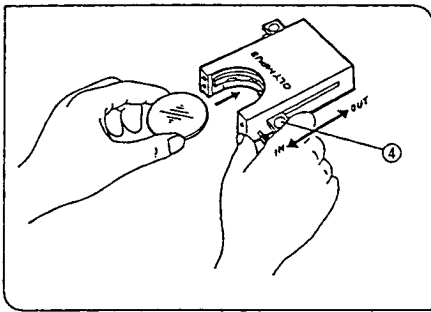

Fig. 26

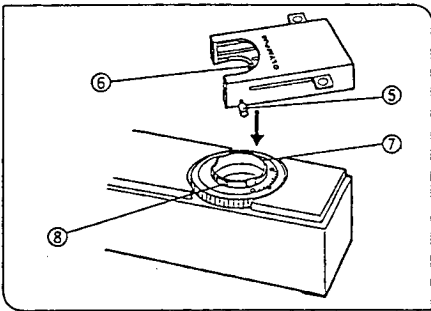

Fig. 27

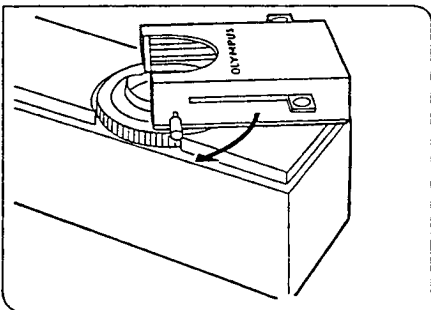

Fig. 28

Using Built-in Filters (Fig. 25)

Three filters are built into the base of the microscope. These filters can be engaged and disengaged using the levers located on the right side of the base.

Each of the three filters ① to ③ can be engaged (IN) by turning its lever so that the ● mark on the lever is aligned with the ● mark on the base. It can be disengaged (OUT) by turning its lever so that the ● mark is aligned with the ○ mark on the base.

- ⊙ Each of the three filters can be switched IN and OUT independently of the others.

	Filter type
①	ND25 (Natural density filter)
②	ND6 (Natural density filter)
③	LBD (Color balancing filter)

Using the Filter Cassette (Figs. 26, 27, 28, 29)

Loading Filters into the Filter Housing (Fig. 26)

- ⊙ The filter housing accommodates filters with a diameter of 45 mm and a thickness of 2.7 mm or less.
  - ⊙ The filter housing has two filter levers on the right side and one on the left side.
1. Move all filter levers to the OUT position except for the one belonging to the slot into which the filter is to be inserted.
  2. Slide lever ④ to the IN position. Make sure that it clicks securely into place. (Fig. 26)
  3. Holding the lever in the position shown, put the filter into the cassette by inserting it in the direction indicated by the arrow.
  4. Insert the other two filters in the same manner.

Mounting the Filter Housing (Figs. 27, 28)

1. Fully loosen the filter cassette clamping screw ⑤. (Fig. 27)
  2. Holding the filter housing above the light exit glass, align the key ⑥ with the slot ⑦ and snap the filter housing into place from above.
  3. Rotate the filter housing to align its sides with the base. (Fig. 28)
  4. Align the clamping screw ⑤ with the positioning hole ⑧ on the light exit, then tighten the screw to fasten the filter cassette.
- ★ When the filter cassette is installed, the stage may hit it when lowered. Therefore, exercise caution when lowering the stage with the filter cassette installed.

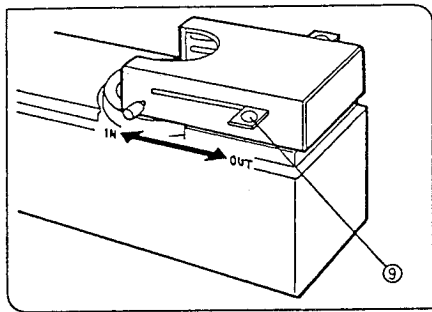

Fig. 29

Using the Filter Cassette (Fig. 29)

Usable filters	Applications	
45LBD-IF	Color balancing filter	
45ND-6, 45ND-25	Neutral density filter	
45G-530, 45G-533, 45IF550	Green	Black & white contrast filters
45Y-48	Yellow	
45O-560	Orange	
45C-3, 45KB-3	Daylight filter	

Up to three of the above filters can be inserted into the filter cassette. Moving the levers ③ on the left and right sides of the cassette to the IN position brings the corresponding filter into the light path.

## 5-2 Brightfield/Darkfield Vertical Illuminator (for Reflected Light)

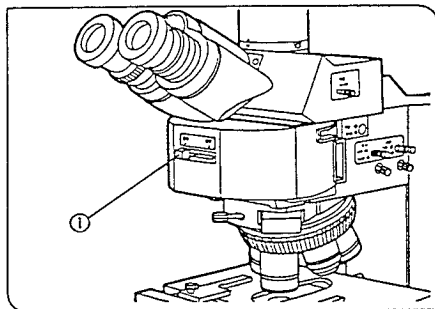

Fig. 30

### 1 Light Path Selection

(Fig. 30)

#### Brightfield/Darkfield Vertical Illuminator Attachment (U-RLBC/U-RLBL)

Select the light path by sliding the cube selector ① to the position indicating the desired observation method.

★ Make sure that the cube selector is moved all the way to the stop positions.

#### Universal Vertical Illuminator Attachment (U-URBC/U-URBL)

Rotate the cube turret to engage the cube (BF or DF) for the desired observation method.

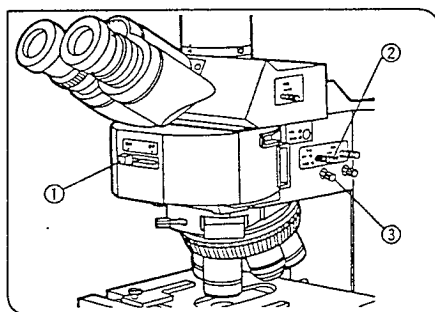

Fig. 31

### 2 Centering the Field Iris Diaphragm

(Fig. 31)

1. Slide the cube selector knob ① to the BF position.
2. Rotate the revolving nosepiece to engage the 10X objective, then place a specimen onto the stage and bring the image into approximate focus.
3. Pull out the field iris diaphragm knob ② on the vertical illuminator to stop down the diameter of the diaphragm a little.
4. Turn the two field iris diaphragm centering knobs ③ to adjust so that the image of the diaphragm is centered in the field of view.
5. To check centration, open the diaphragm by pushing in the field iris diaphragm knob ② until the diaphragm image touches the periphery of the field of view. If the image is not centered precisely, center it again until so.
6. Further enlarge the field iris diaphragm diameter until its image just circumscribes the field of view.

#### Using the Field Iris Diaphragm

##### • Reflected Light Brightfield Observation

To obtain good image contrast, adjust the diameter of the illuminating beam in accordance with the objective in use.

Using the field iris diaphragm knob ② on the vertical illuminator, adjust the diaphragm so that the field of view is circumscribed by the field iris diaphragm in order to exclude stray light.

##### • Reflected Light Darkfield Observation

Always keep the field iris diaphragm knob ② pushed in to leave the diaphragm open.

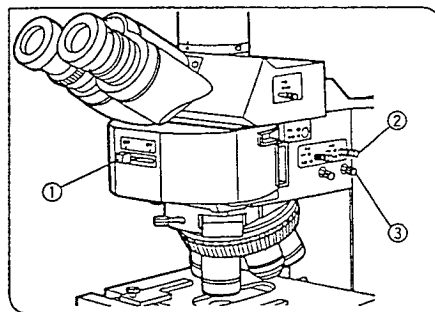
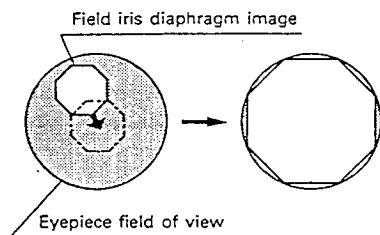

Fig. 32

### 3 Centering the Aperture Iris Diaphragm (Figs. 32, 33)

1. Slide the cube selector knob ① to the BF position.
2. Rotate the revolving nosepiece to engage the 10X objective, then place a specimen on the stage and bring the image into focus.
3. Remove the eyepieces. Looking through the eyepiece sleeves, pull out the aperture iris diaphragm knob ② to leave the diaphragm approximately 70% open.
4. At this point, if the diaphragm is not centered precisely, center it again by manipulating the aperture iris diaphragm centering knobs ③.

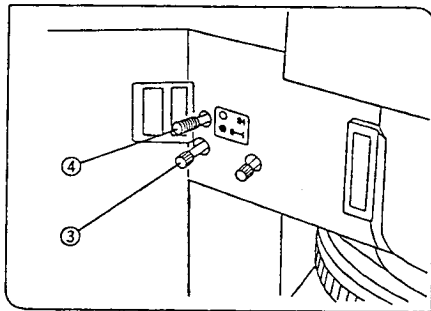
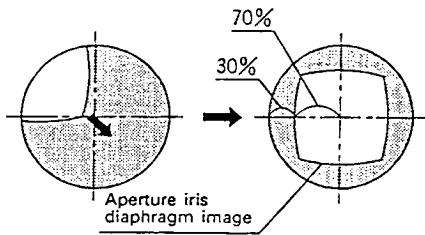

Fig. 33

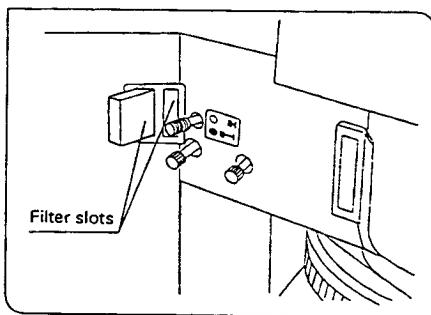

Fig. 34

#### Using the Aperture Iris Diaphragm

- **Reflected Light Brightfield Observation**

In general, a good image is obtained if the diaphragm is stopped down to 70-80% of the objective's numerical aperture.

- **Reflected Light Darkfield Observation**

Always keep the aperture iris diaphragm knob ② pushed in to leave the diaphragm open.

- Ⓞ Depending on the specimen, an image with good contrast and little flare may sometimes be obtained by keeping the aperture iris diaphragm stopped down a little more. Please experiment with this to see if it works with the particular specimen.

#### Using the Pinhole Diaphragm (Figs. 32, 33)

- Ⓞ When using a 250X objective, use the pinhole diaphragm to enhance the effect of the aperture iris diaphragm.
  1. Push in the aperture iris diaphragm knob ② to open the diaphragm. (Fig. 32)
  2. Pull out the pinhole knob ④ to bring the pinhole diaphragm into the light path. (Fig. 33)
    - ★ The pinhole diaphragm is placed at the same position as the aperture iris diaphragm, and centration may be lost when the aperture iris diaphragm is adjusted.
  3. Place a mirror or other highly reflective specimen on the stage. With the eyepieces in place, rotate the fine adjustment knob in the direction where the specimen and objective move away from each other until the contour of the pinhole becomes visible.
  4. At this point, if centration of the pinhole diaphragm is imprecise, use the two aperture iris diaphragm centering knobs ③ to adjust the centration.
  5. Bring the specimen into focus again.
    - ★ If the aperture iris diaphragm is stopped down when using the pinhole diaphragm, flare may occur.
    - ★ The pinhole diaphragm is placed so that it can be centered at the same position as the aperture iris diaphragm. However, due to construction considerations, a certain play exists. This is required for the pinhole diaphragm performance and it does not indicate a malfunction.
    - ★ When using the pinhole diaphragm, contaminants on the eyepieces and photo-eyepiece may become noticeable. To prevent this, clean eyepieces periodically.

## 4 Using the Filters (Fig. 34)

Engage the filters suitable for the particular observation.

Usable filters	Applications
U-LBD Color temperature conversion filter	To convert the color temperature of the source to the color temperature of daylight. Used for comfortable observation and when taking color photographs.
U-IF550 Green filter	To increase contrast during B&W observation. Used when taking B&W photographs.
U-ND25 Neutral density filter	To adjust illumination brightness. (Transmission ratio 25%)
U-ND6 Neutral density filter	To adjust illumination brightness (Transmission ratio 6%)

## 5-3 Stage

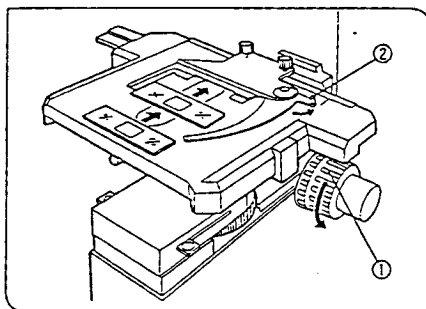

Fig. 35

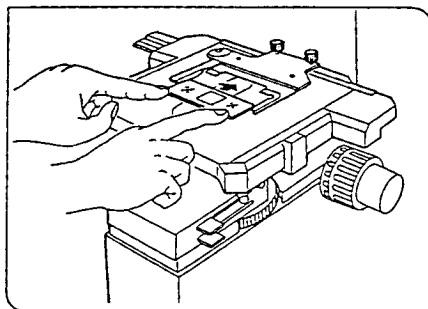

Fig. 36

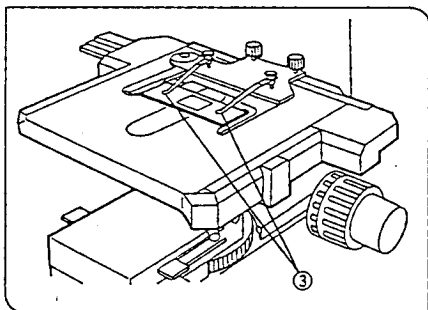

Fig. 37

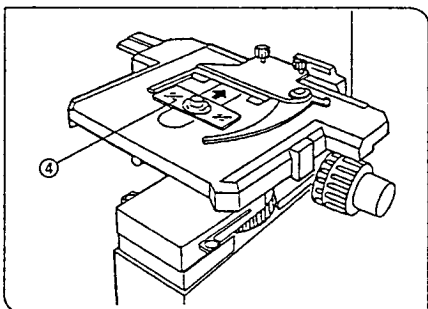

Fig. 38

### 1 Specimen Placement

(Figs. 35, 36, 37, 38, 39, 40)

#### Biological Specimen

(Figs. 35, 36, 37)

- ★ With single slide observations, the maximum slide dimensions are 26 X 76 mm, with a thickness of 0.9-1.4 mm and cover glass thickness of 0.17 mm.
- ★ When observing very large specimens, remove the specimen holder and place the specimen directly on the stage.

#### Specimen Holder for 2 Specimen Slides (Fig. 35)

1. Turn the coarse adjustment knob ① to lower the stage.
2. Open the spring-loaded curved finger ② on the specimen holder and place the specimen slides on the stage from the front.
3. After placing the slides as far as they will go, gently release the curved finger.

#### Specimen Holder for Single Slides (Figs. 36, 37)

The specimen can easily be placed by sliding it into the specimen holder from the front. (Fig. 36)

#### Using an Oil Immersion Objective

Adsorption of immersion oil can cause the specimen to drift. In such cases, it is recommended to use the optional specimen clip ③ (BH2-SCB-3) for oil immersion objectives. (Fig. 37)

#### Metallurgical Specimen

(Figs. 38, 39, 40)

#### U-S.V.

Place a lump of clay (Plasticine) on a metal slide ④, place the specimen on the clay, and gently press the specimen with a hand press to stick the specimen to the metal slide. (Fig. 39)

- ★ Be sure that the surface of the specimen to be observed is perpendicular to the optical axis of the microscope.

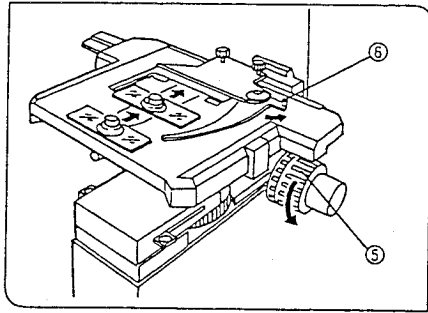

Fig. 39

1. Turn the coarse adjustment knob ⑤ to lower the stage.
2. Open the spring-loaded curved finger ⑥ on the specimen holder and place the specimen slides on the stage from the front.
3. After placing the specimen as far as it will go, gently release the curved finger. (Fig. 39)
  - ★ When observing very large specimens, remove the specimen holder and place the specimen directly on the stage.

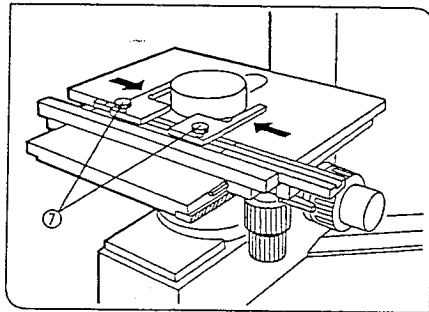

Fig. 40

U-SIC4

After loosening the specimen holder clamping screws ⑦, slide the specimen holder apart to place the specimen. Clamp the specimen holder by tightening the clamping screws ⑦. (Fig. 40)

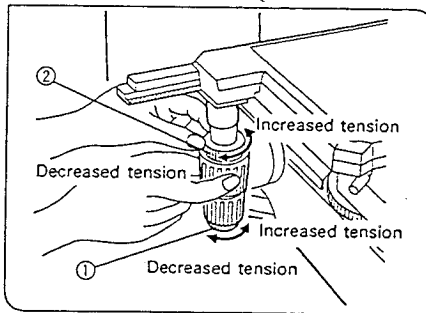

Fig. 41

**2** Adjusting the Tension of the X-axis and Y-axis Knobs

(Figs. 41, 42)

U-SV

- ⊙ The tension of the X-axis and Y-axis knobs can be individually adjusted. Turning the X adjustment ring ① or the Y adjustment ring ② counter-clockwise increases tension, and turning them clockwise reduces tension. When adjusting the tension, hold the X-axis and Y-axis knobs to keep them from turning along with the tension adjustment rings.
  - ★ If the tension is adjusted too tight, a creaking sound may be heard during stage travel, and the stage may backtrack. (Fig. 41)

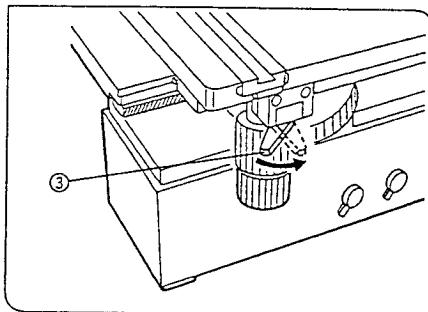

Fig. 42

U-SIC4

- ⊙ This stage has no provision for tension adjustment but vertical travel lock attachment can be used with this stage.
  1. When the Y-axis lock lever ③ is engaged, travel along the Y-axis is blocked while scan in the X-axis direction is free.
  2. When releasing the lock lever, make sure to return the lever to its original position. (Fig. 42)

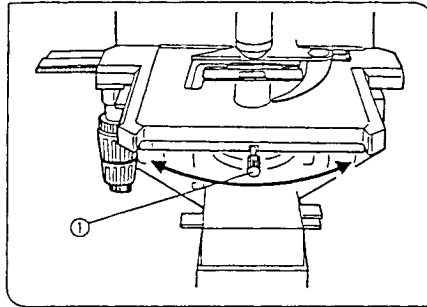

Fig. 43

### 3 Rotating the Stage (Fig. 43)

1. Slightly loosen the stage clamping screw ①.
  2. The stage can be rotated both to the left and to the right by turning it with the stage clamping screw.
- ★ A click may be heard and felt during rotation. However, this is due to the construction of the substage and does not indicate a malfunction.
- ◎ The angle of rotation varies depending on the position of the stage knobs.

	Angle of rotation	
	Clockwise	Counterclockwise
Right hand knobs	230°	20°
Left hand knobs	20°	230°

Specifications are identical for both the standard type and long type handle.

★ The U-SIC stage cannot be rotated.

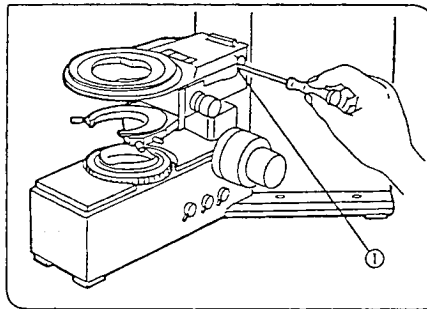

Fig. 44

### 4 Stage Height Adjustment (Fig. 44, 45)

- ◎ By lowering the position of the substage, the microscope will accommodate specimens with maximum heights of 40 mm. This is useful when observing metallurgical specimens and other thick objects.
1. Lower the stage to its lower limit, then remove the stage from the microscope. (See page 3)
  2. Using the Allen screwdriver, loosen the substage bracket clamping screw ① and remove the substage. (Fig. 44)
  3. Turn the coarse adjustment knob and raise the focusing block ③ to where the stopper screw ② in the arm becomes visible. (Fig. 45)
  4. Using the Allen screwdriver, loosen and remove the upper stopper screw ②.
  5. Reattach substage and stage.
- ◎ Store the removed stopper screw ② in a safe place so that it will not be lost, if needed again.

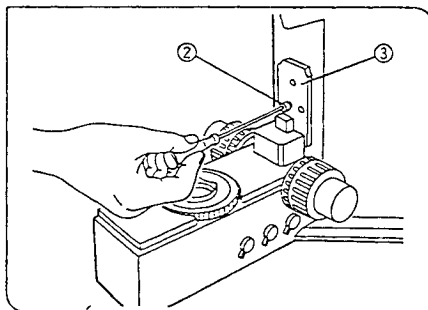

Fig. 45

## 5-4 Observation Tube

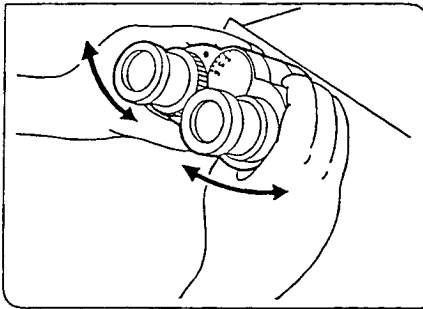

Fig. 46

### 1 Interpupillary Distance Adjustment (Fig. 46)

While looking through the eyepieces, adjust for binocular vision until the left and right fields of view coincide completely. The index dot • indicates the interpupillary distance.

⊙ Note your interpupillary distance so that it can be quickly duplicated.

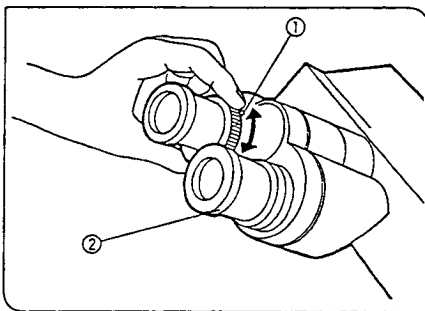

Fig. 47

### 2 Diopter Adjustment (Fig. 47, 48)

1. Looking through the right eyepiece with your right eye, rotate the coarse and fine adjustment knobs to bring the specimen into focus.
2. Looking through the left eyepiece with your left eye, turn the diopter adjustment ring ① to focus on the specimen. (Fig. 47)

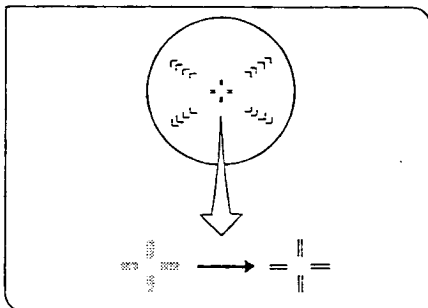

Fig. 48

#### Using a Finder Eyepiece

1. Looking through the right eyepiece with your right eye, turn the top ② of the eyepiece until a clearly defined double crossline can be seen in the field of view. (Figs. 47, 48)
2. Looking through the right eyepiece, rotate the fine adjustment knob to bring the specimen and double crossline into simultaneous focus.
3. Looking through the left eyepiece with your left eye, turn the diopter adjustment ring ① to focus on the specimen.

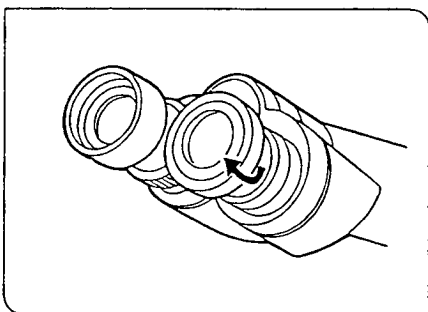

Fig. 49

### 3 Using the Eye Shades (Fig. 49)

#### When Wearing Eyeglasses

Use with the eye shades in their normal folded down position. This will prevent the eyeglasses from being scratched.

#### When Not Wearing Eyeglasses

Extend the folded eye shades in the direction of the arrow for efficient use of the eye shades. (Fig. 49)

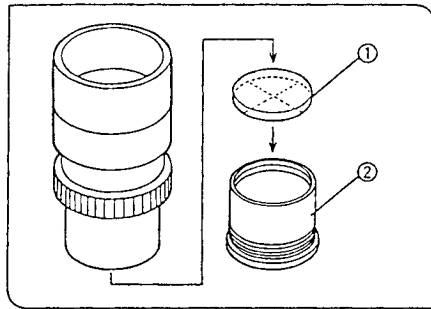

Fig. 50

**4 Using Eyepiece Micrometers** (Fig. 50)

Eyepiece micrometers can be inserted into WH10X-H and WH10X eyepieces.

Use 24 mm diam. X 1.5 mm micrometer discs. Following Fig. 50, unscrew the micrometer frame (2) from the eyepiece and place a micrometer disc (1) into the frame. The engraving on the micrometer disc (1) should face downward into the micrometer frame (2). Screw the micrometer frame into the eyepiece as it was before.

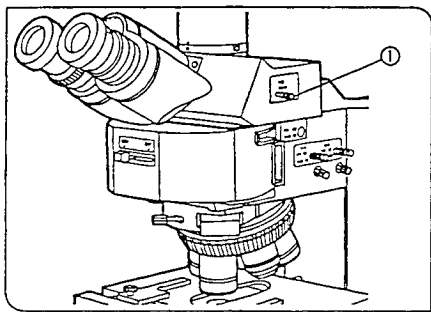

Fig. 51

**5 Light Path Selection (U-TR30, U-SWTR)** (Fig. 51)

Slide the light path selector knob (1) to select the desired light path.

- ⊙ The selector knob is ordinarily at the middle position. With dark specimens, push the knob in. If additional light is needed for television or photomicrography, pull the knob out.

Light path selector knob	Symbol	Intensity ratio	Application
Pushed in		100% for binocular eyepieces	Observation of dark specimens
Middle position		20% for binocular eyepieces, 80% for TV/photography	Observation of bright specimens, photography, TV observation
Pulled out		100% for TV/photography	Photography, TV observation

## 5-5 Condenser

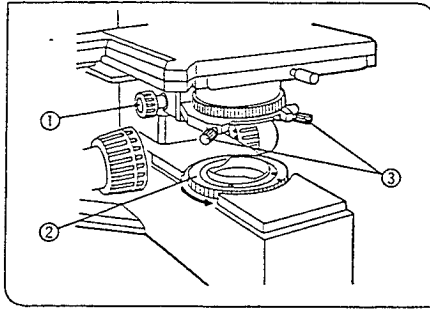
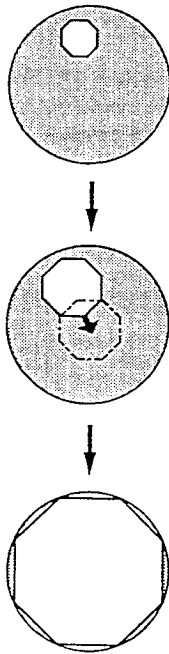

Fig. 52



### 1 Condenser Centration

(Figs. 52, 53, 54)

1. Turn the condenser height adjustment knob ① and raise the condenser to its upper limit. (Fig. 52)
2. Focus on the specimen using the 10X objective.
  - ★ When using the U-SC swing-out condenser, move the top lens into the light path.
3. Rotate the field iris diaphragm ring ② in the direction of the arrow to where the diameter of the diaphragm image is at its smallest.
4. Turn the condenser height adjustment knob ① to where the diaphragm image is seen in sharp focus within the field of view.
5. Turn the two condenser centering screws ③ to move the diaphragm image to the center of the field of view.
6. Gradually open the field iris diaphragm. The condenser is properly centered if the diaphragm image is centered and inscribed in the field of view.
7. During actual use, open the field diaphragm slightly until its image circumscribes the field of view.

#### Field Iris Diaphragm

The field iris diaphragm restricts the diameter of the beam of light entering the objective and thus excludes extraneous light, improving image contrast. The diameter of the field iris should be adjusted for each objective power to the extent that it just circumscribes the field of view. (See "Compatibility of Objectives and Condensers" on the next page.)

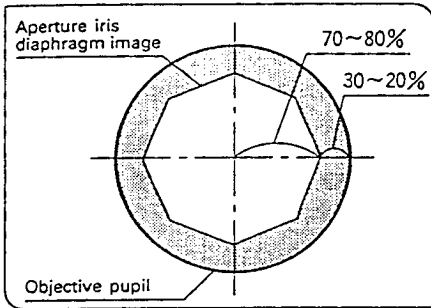

Fig. 53

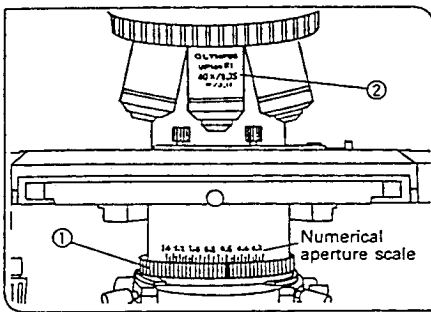

Fig. 54

Aperture Iris Diaphragm (Figs. 53, 54)

- The aperture iris diaphragm determines the numerical aperture of the illumination system. Matching the numerical aperture of the illumination system with that of the objective provides better image resolution and contrast, and also increases the depth of focus.
- Since the contrast of microscope specimens is ordinarily low, setting the condenser aperture iris diaphragm to 70-80% of the N.A. of the objective in use is usually recommended. When necessary, adjust the ratio by removing the eyepiece and looking into the eyepiece sleeve while adjusting the aperture iris diaphragm ring ① until the image shown in Fig. 53 is seen.

④ Using the Numerical Aperture Scale

Set the condenser numerical aperture scale ① to about 80% of the NA value ② indicated on the objective. (Fig. 54)

Example:

With the Plan 40X (NA 0.65), set the scale to  $0.65 \times 0.8 = 0.5$ .

Compatibility of Objectives and Condensers

Objective magnification	Condenser			
	Abbe U-AC	Achromat/Aplanat U-AAC	Swing-out U-SC	Ultra-low magnification U-ULC
1.25X	/	/	Usable by moving top lens out of the light path.*1	Usable
2X				
4X	Usable to FN22	Usable	Top lens in light path NA not fully matched to objective NA*2	/
10-60X	Usable			
100X				

\*1 When using the U-SC swing-out condenser together with the 2X or 4X objective, fully open the condenser aperture and use the field iris diaphragm in the base as aperture diaphragm.

\*2 The slightly lower NA results in a somewhat darker field of view with a 100X objective, but the combination is usable.

④ To obtain better illumination, use of the U-ULC is recommended in photomicrography when using the 2X or 4X objective.

## 5-6 Focusing Adjustment Knobs

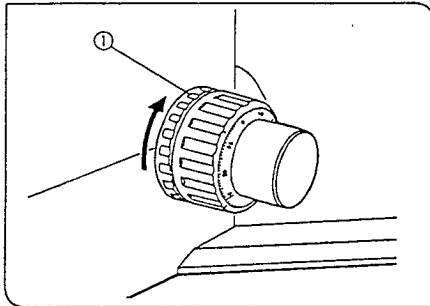

Fig. 55

### 1 Adjusting the Coarse Adjustment (Fig. 55)

- ⊙ Adjust the coarse adjustment knob tension using the tension adjustment ring ①.

The coarse adjustment knob tension is preadjusted for easy use. However, if desired, one can change the tension using the tension adjustment ring ①. Turning the ring in the direction of the arrow increases tension, and vice versa.

The tension is too low if the stage drops by itself or focus is quickly lost after adjustment with the fine adjustment knob. In this case, turn the ring in the direction of the arrow to increase tension.

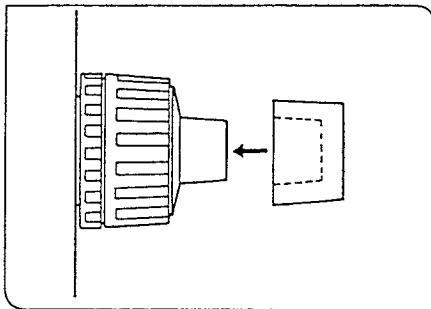

Fig. 56

### 2 Using the Fine Adjustment Knob Rubber Cap (Fig. 56)

- ⊙ Ordinarily, the fine adjustment knob is used with the rubber cap attached. However, if space between the knob and the stage controls is insufficient, the cap may be removed. The cap makes it easier to turn the fine adjustment knob in small increments to obtain more accurate focus.

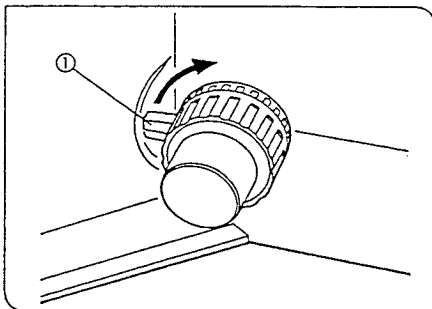

Fig. 57

### 3 Pre-focusing Lever (Fig. 57)

- ⊙ The pre-focusing lever ensures that the objective does not come in contact with the specimen and simplifies focusing. After focusing on the specimen with the coarse adjustment knob, turn this lever ① in the direction of the arrow to set an upper limit on coarse adjustment movement. After changing specimens, refocusing is easily accomplished by rotating the coarse adjustment knob to reach the pre-focused position, then making fine adjustments with the fine adjustment knob.

- ⊙ Stage movement with the fine adjustment knob is not affected by this pre-focusing lever.

## 5-7 Immersion Objectives (for biological purposes only)

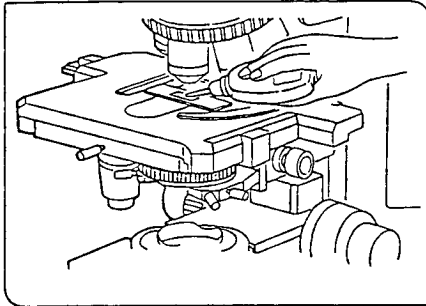
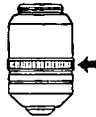

Fig. 58

### Using The Cover Glass Correction Collar

This objective is equipped with an adjustable collar to correct for spherical aberrations caused by too thick or too thin cover glasses. If the thickness of the cover glass is unknown, the optimum position for the correction collar can be obtained by judging the image resolution. When a satisfactory image is not obtained after focusing, rotate the correction collar to the left or the right and refocus to compare the image at both sides. Return the collar to the position yielding the improved image; then starting from this position, further rotate the collar slightly to the right or left, refocusing each time, to compare the image at each position. Repeat this procedure until the position with optimum image sharpness is found.

Neglecting this adjustment will impede optimum performance. When rotating the revolving nosepiece, do not touch the correction collar (indicated by the arrow).



### 1 Use of Immersion Objectives

(Fig. 58)

1. Focus on the specimen with a low power objective.
2. Place a drop of immersion oil (provided) onto the specimen at the area to be observed.
3. Turn the revolving nosepiece to engage the immersion objective, then focus using the fine adjustment knob.
  - ★ Since bubbles in the oil will affect the image quality, make sure that the oil is free of bubbles.
    - a. To check for bubbles, remove the eyepiece and fully open the field and aperture iris diaphragms, then look at the exit pupil of the objective inside the observation tube. (The pupil should appear round and bright.)
    - b. To remove bubbles, rock the nosepiece slightly to move the oil immersion objective back and forth a few times.
- ⊙ If the condenser marking shows a numerical aperture (NA) of 1.0 or more, the number applies only when oil is present between the slide glass and the top surface of the condenser. When oil is not present, the NA is about 0.9.
4. After use, remove oil from the objective front lens by wiping with gauze slightly moistened with xylene or a mixture of ether (70%) and alcohol (30%).
  - ★ Excessive amounts of xylene may dissolve the adhesive of the objective.

## 5-8 Photomicrography

- ⊙ Use a trinocular observation tube (U-TR30, U-SWTR) for photomicrography.

Photomicrography can be performed using the PM-10, the PM-20, or the PM-30 photomicrographic systems. Procedures for operating the photomicrographic units are described in their respective instruction manuals. Procedures specific to this microscope are described below.

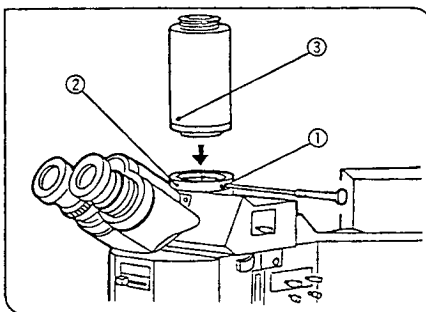

Fig. 59

### 1 Attaching the Straight Photo Tube (U-SPT) (Fig. 59)

1. Using the Allen screwdriver, loosen the clamping screw ① on the trinocular tube photo port.
2. Align the index dot ② with the index dot ③ on the straight photo tube, then mount the straight photo tube on the trinocular tube photo port.
3. Tighten the clamping screw ①.

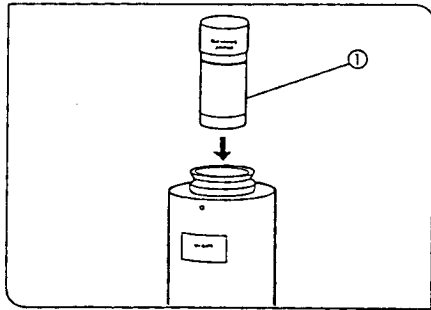

Fig. 60

**2 Photo Eyepiece** (Fig. 60)

Use only a PE photo eyepiece for photomicrography. Insert the photo eyepiece ① with the desired magnification into the straight photo tube mounted on the trinocular observation tube.

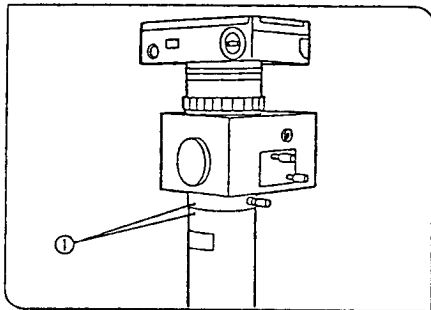

Fig. 61

**3 Mounting the Camera Unit** (Fig. 60)

Place the camera unit directly over the circular dovetail of the straight photo tube. Make sure the index dots ① on the straight photo tube and the camera unit are aligned, then clamp the unit.

**4 Selecting the Observation Tube Light Path**

See page 26 of the "Observation Tube" section.

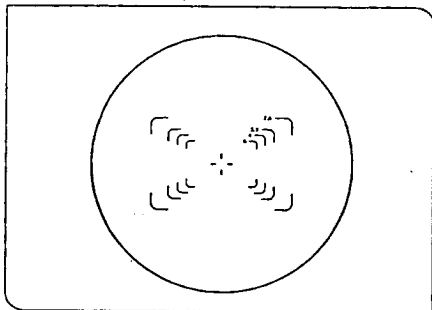

Fig. 62

**5 Focus Adjustment** (Fig. 62)

1. Camera focusing is done using the binocular section of the trinocular observation tube.
  - ★ Whenever you remove the focusing telescope from the camera unit, be sure to install the dust cap.
2. Insert a finder eyepiece into the right eyepiece sleeve.
3. The finder eyepiece has a reticle with four masks and a double crossline, and the focus is for all purposes the same for the reticle and the camera film plane. The masks indicate the areas covered, and the numerals next to the masks correspond to the magnification of the photo eyepiece. Different finder eyepieces are available for different cameras. Select the type that is appropriate for the camera being used.
4. Because of the great depth of focus of 1.25X to 4X objectives, use of the focusing magnifier (U-FT) is recommended for accurate focusing.
  - ◎ When using low power objectives, focusing may be accomplished easier using the focusing telescope on the camera unit rather than the finder eyepiece.

## 6-1 Transmitted Light Brightfield Observation

★ Disengage the analyzer, polarizer, glare shielding ND filter, and ND filter used for reflected light observation.

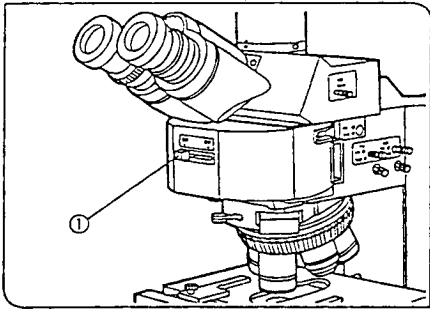

Fig. 63

### 1 Selecting the Light Path for Observation (Fig. 64)

#### Mirror Cube Housing

Slide the cube selector knob ① all the way to the DF position.

#### Cube Housing

Rotate the cube turret to engage the empty cube compartment.

## 6-2 Reflected Light Brightfield/Darkfield Observation

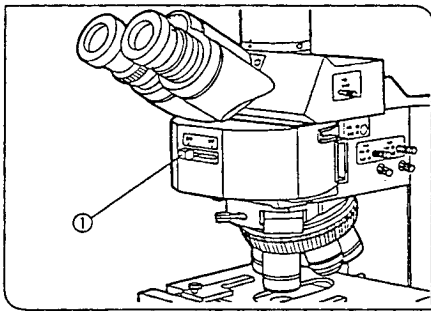

Fig. 64

### 1 Selecting the Light Path for Observation (Fig. 64)

#### Mirror Cube Housing

Select the light path by sliding the cube selector ① to the position indicating the desired observation method (BF or DF).

#### Cube Housing

Rotate the cube turret to engage either the BF or DF cube.

	Cube index	Field iris diaphragm	Aperture iris diaphragm	Glare shielding ND
Reflected light brightfield	BF	Adjust as necessary		IN
Reflected light darkfield	DF	Open		

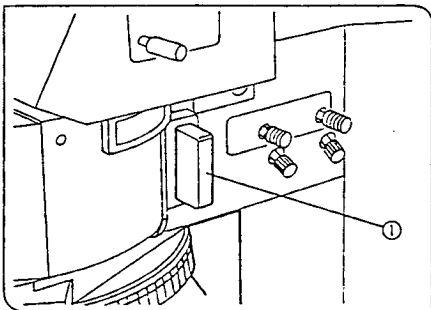

Fig. 65

### 2 Glare Shielding ND Filter (U-DND) (Fig. 65)

1. Insert the glare shielding ND filter ① with the side with engraving facing forward into the filter slot on the right side of the vertical illuminator.
2. As you insert the filter, you will hear two clicks. At the first, the filter is in the empty position, and at the second the filter is in the light path.
3. Ordinarily, if the ND filter is in the light path, it will prevent the glare effect otherwise noticeable when switching from darkfield to brightfield.

Ⓞ When the illumination is too low during brightfield observation, or if needed to shorten the exposure time during photomicrography, or to brighten the field of view during darkfield observation, remove the filter from the light path.

## 6-3 Reflected Light Nomarski Differential Interference Contrast Observation

★ When using the DIC prism U-DICRH for observation with sensitive color, use it in combination with the polarizer U-POTP.

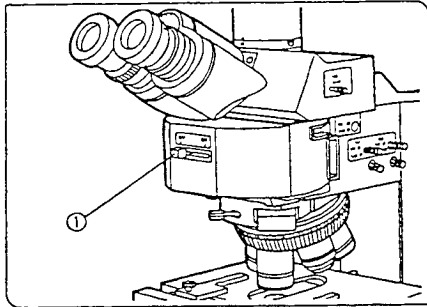

Fig. 66

### 1 Selecting the Light Path for Observation (Fig. 66)

#### Mirror Cube Housing

1. Slide the cube selector knob ① all the way to the BF position.

#### Cube Housing

- Rotate the cube turret to engage the BF cube in the light path.
- When the U-MDIC differential interference contrast cube is inserted in the cube cassette, engage the U-MDIC in the light path.

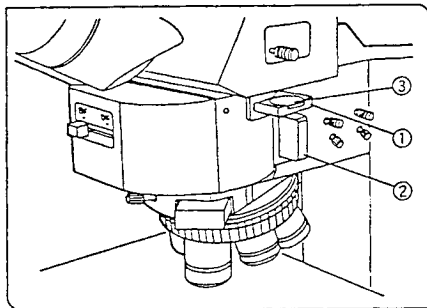

Fig. 67

### 2 Installing Analyzer and Polarizer (Fig. 67)

- When the U-MDIC differential interference contrast cube is inserted in the cube cassette, it is unnecessary to mount and adjust the analyzer and polarizer.
- 1. Insert the U-AN360 analyzer with the engraving facing upward into ① and the U-PO polarizer with the engraving facing forward into ② to engage them both into the light path.
- 2. Rotate the U-AN360 polarizer dial ③ until complete extinction is obtained.
- When the dial's index mark is located on the outside, away from the microscope, this position will almost correspond to the crossed Nicols position. Turn the dial around this point until complete extinction is obtained.

#### "OPERATOR SERVICE"

### 3 Installing the Nomarski Prism (Fig. 68)

#### "OPERATOR SERVICE"

1. Loosen the DIC clamping screw ① at the front of the revolving nose-piece and remove the dummy slider. Then insert the U-DICR differential interference contrast prism ② with the side with the engraving facing upward. Tighten the clamping screw to secure the prism.
2. If a UMPlan objective is used, push in the selector lever ③. If an LMPlan objective is used, pull out the selector lever.
  - ★ Since the U-DICRH is not provided with a selector lever, it cannot be used with the LMPlanFI series and LMPlanApo series objectives.

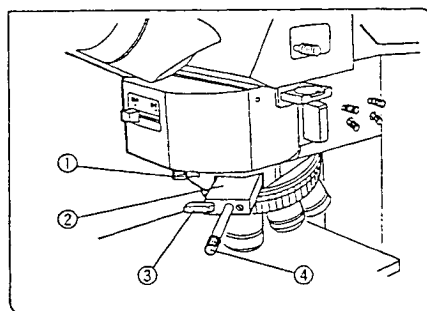

Fig. 68

## 4 Observation Method

(Fig. 68)

★ The LBD filter will make the interference contrast image bluish if engaged. Remove the filter from the light path.

1. Place the specimen on the stage and move the stage to bring the specimen into focus.
2. Adjust the field iris diaphragm until the diaphragm opening circumscribes the field of view.
3. Stopping down the aperture iris diaphragm may increase the contrast somewhat.

### U-DICR

1. Rotate the prism control knob ④ of the DIC prism slider to select the interference color of the background, and to achieve the maximum contrast depending on the specimen under observation, as outlined below. (Fig. 68)
2. Rotating the prism control knob of the U-DICR slider will continuously change the interference color of the background from gray to magenta (–100–600 nm).
  - If the background color is black (0-order fringe), darkfield-like observation is possible.
  - If the background color is gray, a three-dimensional looking image with maximum contrast can be obtained.
  - If the background color is magenta, even a minor optical retardation can be observed as a color change.

### U-DICRH

1. Rotate the prism control knob ④ of the DIC prism slider to select the interference color of the background, and to achieve the maximum contrast depending on the specimen under observation, as outlined below. (Fig. 68)
2. Rotating the prism control knob of the U-DICRH slider will continuously change the interference color of the background from –100 to 100 nm. Select the retardation offering optimum contrast.
  - If the background color is black (0-order fringe), darkfield-like observation is possible.
  - If the background color is gray, a three-dimensional looking image with maximum contrast can be obtained.
  - If the background color is magenta, even a minor optical retardation can be observed as a color change.To use the magenta sensitive color, use the polarizer U-POTP. Position the polarizer so that the  $\lambda$  symbol can be seen from the front when the polarizer is inserted into the slot.

★ Care should be taken to keep the specimen surface clean, as even a small amount of contamination on the surface may show up due to the exceptionally high sensitivity of the differential interference contrast method.

◎ As differential interference contrast exhibits directional sensitivity, the use of a rotatable stage is recommended.

## 5 Switching Between Brightfield and Darkfield Observation

(Fig. 68)

1. Loosen the DIC clamping screw ① at the front of the revolving nosepiece, and gently pull the U-DICR differential interference contrast prism ② out to the clickstop. Then tighten the clamping screw again.
2. Disengage both the U-AN360 analyzer and the U-PO polarizer from the light path. Rotate the turret to disengage the U-MDIC differential interference contrast cube.

## 6-4 Reflected Light Simple Polarized Light Observation

◎ To prepare for simple polarized light observation using the vertical illuminator, perform steps 1 and 2 in Section 6-3, Reflected Light Nomarski Differential Interference Contrast Observation outlined on page 33.

### 1 Observation

1. Place the specimen on the stage and then operate the coarse and fine focus knobs to bring the specimen into focus. Simple polarized light observation is now possible.
2. Adjust the field iris diaphragm until the diaphragm opening circumscribes the field of view.
3. Stopping down the aperture iris diaphragm may increase the contrast somewhat.

## 6-5 Reflected Light Fluorescence Observation

The U-URBC cube housing to be used offers the same performance as the U-URA universal reflected light fluorescence vertical illuminator used with the BX-FLA reflected light fluorescence attachment. Operation is almost similar. For details on reflected light fluorescence observation, see the manual pertaining to the BX-FLA reflected light fluorescence attachment.

### 1 Nomenclature

- ⊙ When the U-URBC cube housing and the U-URBL collector lens unit are combined with the BX60 microscope frame, you get the same configuration as in the case of the U-URA.

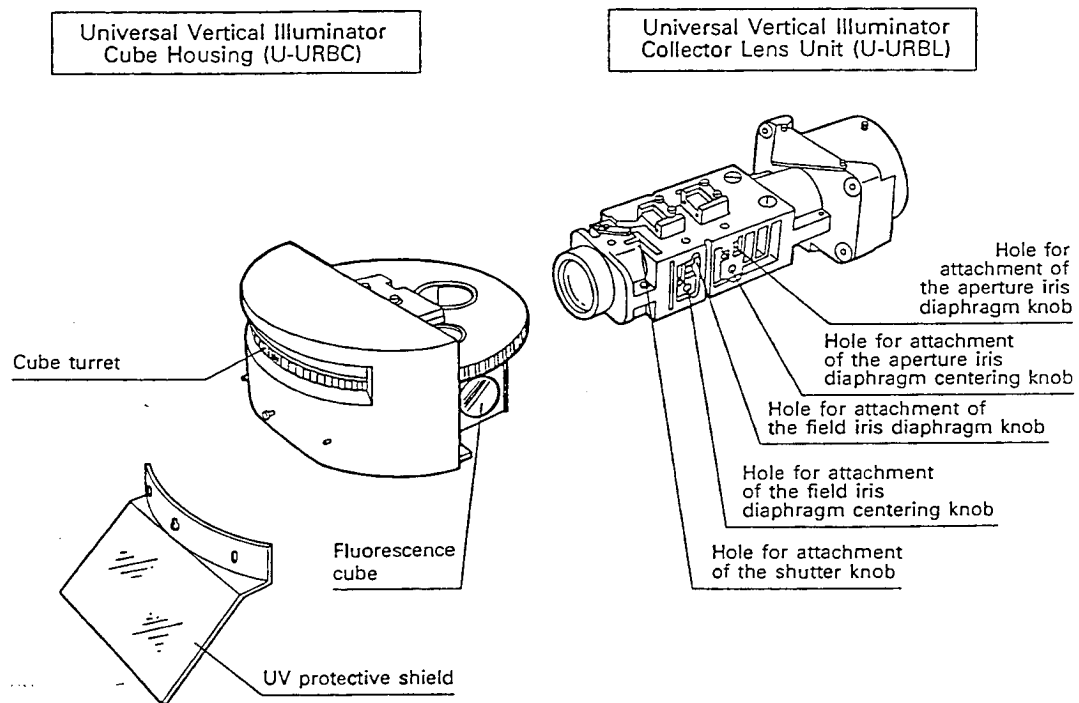

### 2 Observation

For details on observation, see the manual pertaining to the U-FLA universal reflected light fluorescence attachment. Also refer to the sections on simultaneous reflected light fluorescence and transmitted light phase contrast observation, and simultaneous reflected light fluorescence and transmitted light Nomarski differential interference contrast observation.

Item	Specification				
(1) Optical system	UIS (Universal Infinity System) optical system				
(2) Transmitted light illumination	Built-in transmitted Koehler illumination (Super widefield applicable: Field number 26.5)				
(3) Reflected light illumination	Brightfield/darkfield mirror cube housing/ collector lens unit		Universal cube housing/ collector lens unit		
	Observation tube magnification: 1X; (Super widefield applicable: Field number 26.5)				
	Observation mode selection: Slide system BF ↔ DF		Observation mode selection: Turret system (max. four cubes)		
	Possible observation modes: <ul style="list-style-type: none"> <li>• Reflected light brightfield</li> <li>• Reflected light darkfield</li> <li>• Reflected light Nomarski differential interference contrast</li> <li>• Reflected light simple polarized</li> <li>• Transmitted light</li> </ul>		Possible observation modes: <ul style="list-style-type: none"> <li>• Reflected light fluorescence</li> <li>• Reflected light fluorescence/ transmitted light Nomarski differential interference contrast</li> <li>• Reflected light fluorescence/ transmitted light phase contrast</li> <li>• Reflected light brightfield</li> <li>• Reflected light darkfield</li> <li>• Reflected light Nomarski differential interference contrast</li> <li>• Reflected light simple polarized</li> <li>• Transmitted light</li> </ul>		
(4) Electrical system (transmitted light/ reflected light)	12V 100W Halogen bulb (pre-centered) 12V 100W HAL-L (PHILIPS 7724) Light intensity DC 1.0V-12.0V (continuous) Light preset switch (setting range 1.0V-12.0V) Rated current 100-120/220-240V-2.8/1.8A 50/60 Hz Fuse $\Rightarrow$ T5A(H) 250V (LITTELFUSE 215005) Transmitted light/reflected light selector switch				
(5) Focusing	Stage movement by roller guide (Rack & Pinion) Stroke per rotation: 0.1 mm (fine), 15 mm (coarse) Full range stroke: 25 mm Upper limit stopper Torque adjustment on coarse focus knob				
(6) Revolving nosepiece	Type	U-6RE Sextuple	U-5BDRE Quintuple	U-D5BDRE Universal reversed quintuple	U-D6RE Universal reversed sextuple
	Attachment	None		DIC prism for transmitted light	
(7) Observation tube	Type	U-BI30 Widefield binocular		U-TR30 Widefield trinocular	U-SWTR Super widefield trinocular
	Field No.	22			26.5
	Tube inclination	30°			
	Interpupillary distance adjustment	50 mm - 76 mm			
	Light path selector	None		3 steps: ① Bi 100% ② Bi 20%, photo 80% ③ Photo, video 100%	

Item	Specification			
(8) Stage	Type	U-SVRD (B) Common axis with low positioned coaxial knobs on the right side (rectangular ceramic coated stage)	U-SVLD (B) Common axis with low positioned coaxial knobs on the left side (rectangular ceramic coated stage)	U-SIC4L (R) Large mechanical stage with left-hand (right-hand) low drive control knobs
	Size	135 mm (D) X 180 mm (W)		169 mm (D) X 216 mm (W)
	Movement mechanism	Adjustable vertical and horizontal knob tension Movement range: 52 mm vertically, 76 mm horizontally		Movement range: 100 mm vertically, 105 mm horizontally
	Specimen holder	Double slide holder*		Adjustable
(9) Condenser	Type	U-AC Abbe condenser	U-SC Swing-out condenser	U-AAC Achromat aplanat condenser
	N.A.	1.25	0.9 - 0.16	1.40
	Aperture iris diaphragm	With numerical aperture scale		
	Applicable objectives	4X to 100X (for wide-field observations) 10X-100X (for super wide-field observations)	2X to 100X (for wide to super widefield observations)	10X to 100X (for wide to super widefield observations)

\*One-hand operation slide holder

Operating environment	<ul style="list-style-type: none"> <li>• Indoor use</li> <li>• Altitude up to 2000 m</li> <li>• Temperature: 5° to 40°C (41° to 104°F)</li> <li>• Maximum relative humidity 80% for temperatures up to 31°C (88°F) decreasing linearly to 50% relative humidity at 40°C (104°F)</li> <li>• Main supply voltage fluctuations not to exceed ±10% of the nominal voltage</li> <li>• Installation/Overvoltage Category II (In accordance with IEC664)</li> <li>• Pollution Degree 2 (In accordance with IEC664)</li> </ul>
-----------------------	--

# OPTICAL CHARACTERISTICS

## Biological Microscopy

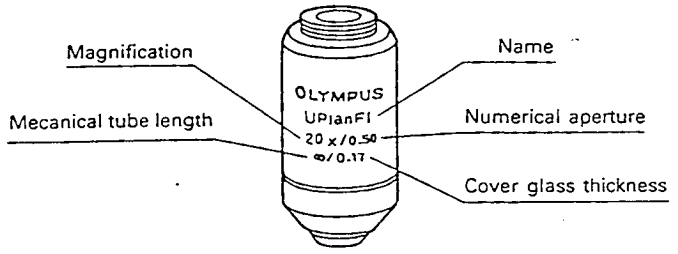

Optical character  Objectives	Mag.	N.A.	W.D. (mm)	Cover glass thickness	Reso- lution (μm)	Eyepiece						Remarks
						WH10X (FN22)			WH15X (FN14)			
						Total mag.	Depth of focus (μm)	Field of view	Total mag.	Depth of focus (μm)	Field of view	
Ach/Ach-P Achromat/ Achromat for polarized light (FN22) 60X, 100XOI (Ach only)	10X	0.25	6.1	—	1.34	100X	28.0	2.2	150X	20.9	1.4	Iris
	20X	0.40	3.0	—	0.84	200X	6.09	1.1	300X	4.64	0.7	
	40X	0.65	0.45	0.17	0.52	400X	3.04	0.55	600X	2.35	0.35	
	60X	0.80	0.15	0.17	0.42	600X	1.76	0.37	900X	1.39	0.23	
	100XOI	1.25	0.13	—	0.27	1000X	0.69	0.22	1500X	0.55	0.14	
	100XOI	0.6-1.25	0.13	—	0.27	1000X	0.69	0.22	1500X	0.55	0.14	
Plan Plan Achromat (FN22)	4X	0.10	22.0	—	3.36	40X	175	5.5	60X	85.8	3.5	Iris
	10X	0.25	10.5	—	1.34	100X	28.0	2.2	150X	20.9	1.4	
	20X	0.40	1.2	0.17	0.84	200X	6.09	1.1	300X	4.65	0.7	
	40X	0.65	0.56	0.17	0.52	400X	3.04	0.55	600X	2.35	0.35	
	50XOI	0.50-0.90	0.20	—	0.37	500X	1.75	0.44	750X	1.30	0.28	
	100XOI	1.25	0.15	—	0.27	1000X	0.69	0.22	1500X	0.55	0.14	
UPlan FI/ UPlan FI-P Universal Semi Apochromat/ polarized light Universal Plan Semi Apochromat (FN26.5) 100XOI (UPlan FI only)	4X	0.13	17.0	—	2.58	40X	127	5.5	60X	92.9	3.5	Iris
	10X	0.30	10.0	—	1.12	100X	22.4	2.2	150X	16.5	1.4	
	20X	0.50	1.6	0.17	0.67	200X	7.00	1.1	300X	5.22	0.7	
	40X	0.75	0.51	0.17	0.45	400X	2.52	0.55	600X	1.93	0.35	
	100XOI	1.30	0.10	0.17	0.26	1000X	0.66	0.22	1500X	0.52	0.14	
	100XOI	0.60-1.30	0.10	0.17	0.26	1000X	0.66	0.22	1500X	0.52	0.14	
UPlan Apo Universal (FN26.5)	4X	0.16	13.0	—	2.1	40X	99.5	5.5	60X	71.7	3.5	Collar Iris Iris
	10X	0.40	3.1	0.17	0.84	100X	15.9	2.2	150X	11.5	1.4	
	20X	0.70	0.65	0.17	0.48	200X	4.65	1.1	300X	3.39	0.7	
	40X	0.85	0.2	0.11-0.23	0.39	400X	2.14	0.55	600X	1.62	0.35	
	40XOI	0.5-1.00	0.12	—	0.34	400X	1.70	0.55	600X	1.30	0.35	
	100XOI	0.5-1.35	0.10	0.17	0.25	1000X	0.62	0.22	1500X	0.49	0.14	
Plan Apo (FN26.5)	1.25X	0.04	5.1	—	8.38	12.5X	872	17.6	18.75X	639	11.2	Collar Iris
	2X	0.08	6.2	—	4.19	20X	398	11.0	30X	287	7.0	
	40X	0.95	0.13	0.11-0.23	0.35	400X	1.86	0.55	600X	1.40	0.35	
	60XOI	1.40	0.10	0.17	0.24	600X	0.85	0.37	900X	0.64	0.23	
	100XOI	1.40	0.10	0.17	0.24	1000X	0.59	0.22	1500X	0.47	0.14	
No Cover Universal Plan Semi Apochromat UMPan FI (FN26.5)	40X	0.75	0.63	0	0.45	400X	1.66	0.55	600X	1.27	0.35	
No Cover Plan Apochromat MPlan Apo (FN26.5)	100XOI	1.40	0.08	0	0.24	1000X	0.59	0.22	1500X	0.47	0.14	

# Metallurgical Microscopy

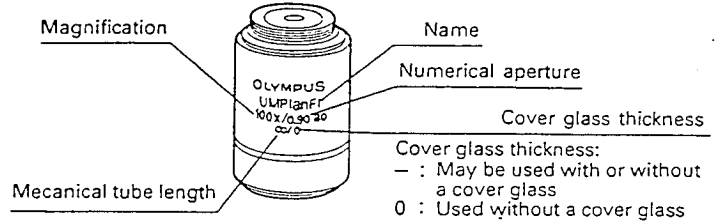

Optical character Objectives	Mag.	N.A.	W.D. (mm)	Cover glass thickness	Resolution ( $\mu\text{m}$ )	Eyepiece						Remarks
						WH10X (FN22)			WH15X (FN14)			
						Total mag.	Depth of focus ( $\mu\text{m}$ )	Field of view	Total mag.	Depth of focus ( $\mu\text{m}$ )	Field of view	
MPlan Plan Achromat (FN22)	5X 10X 20X 50X 100X	0.10 0.25 0.40 0.75 0.90	19.6 10.6 1.3 0.38 0.21	— — 0 0 0	3.36 1.34 0.84 0.45 0.37	50X 100X 200X 500X 1000X	97.5 18.4 6.09 1.42 0.73	4.4 2.2 1.1 1.44 0.22	75X 150X 300X 750X 1500X	74.2 13.7 4.64 1.11 0.60	2.8 1.4 0.7 0.28 0.14	
MPlan-BD* Plan Achromat for brightfield/darkfield (FN22)	5X 10X 20X 50X 100X	0.10 0.25 0.40 0.75 0.90	12.0 6.5 1.3 0.38 0.21	— — 0 0 0	3.36 1.34 0.84 0.45 0.37	50X 100X 200X 500X 1000X	97.5 18.4 6.9 1.42 0.73	4.4 2.2 1.1 0.44 0.22	75X 150X 300X 750X 1500X	74.2 13.7 4.64 1.11 0.60	2.8 1.4 0.7 0.28 0.14	
UMPlan FI Universal Plan Semi Achromat (FN26.5)	5X 10X 20X 40X 50X 100X	0.15 0.30 0.46 0.75 0.80 0.95	20.0 10.1 3.1 0.63 0.66 0.31	— — 0 0 0 0	2.24 1.12 0.73 0.45 0.42 0.35	50X 100X 200X 400X 500X 1000X	58.9 14.7 5.10 1.66 1.30 0.67	4.4 2.2 1.1 0.55 0.44 0.22	75X 150X 300X 600X 750X 1500X	43.3 10.8 3.84 1.27 1.01 0.55	2.8 1.4 0.7 0.35 0.28 0.14	
UMPlan FI-BD Universal Plan Semi Achromat for brightfield/darkfield (FN26.5)	5X 10X 20X 50X 100X	0.15 0.30 0.46 0.80 0.90	12.0 6.5 3.0 0.66 0.31	— — 0 0 0	2.24 1.12 0.73 0.45 0.37	50X 100X 200X 500X 1000X	58.9 14.7 5.10 1.30 0.73	4.4 2.2 1.1 0.44 0.22	75X 150X 300X 750X 1500X	43.3 10.8 3.84 1.01 0.60	2.8 1.4 0.7 0.28 0.14	
UMPlan FI-BDP Universal Plan Semi Achromat for reflected light polarized light (FN26.5)	5X 10X 20X 50X 100X	0.15 0.25 0.40 0.75 0.90	12.0 6.5 3.0 0.66 0.31	— — 0 0 0	2.24 1.34 0.84 0.45 0.37	50X 100X 200X 500X 1000X	58.9 18.4 6.09 1.42 0.73	4.4 2.2 1.1 0.44 0.22	75X 150X 300X 750X 1500X	43.3 13.7 4.64 1.11 0.60	2.8 1.4 0.7 0.28 0.14	
LMPlan FI Long working distance plan Semi Achromat for brightfield/darkfield (FN26.5)	20X 50X 100X	0.40 0.50 0.80	12.0 10.6 3.4	0 0 0	0.84 0.67 0.42	200X 500X 1000X	6.09 2.50 0.87	1.1 0.44 0.22	300X 750X 1500X	4.64 2.03 0.72	0.7 0.28 0.14	
LMPlan FI-BD Long working distance plan Semi Achromat for brightfield/darkfield (FN26.5)	20X 50X 100X	0.40 0.50 0.80	12.0 10.6 3.3	0 0 0	0.84 0.67 0.42	200X 500X 1000X	6.09 2.50 0.87	1.1 0.44 0.22	300X 750X 1500X	4.64 2.03 0.72	0.7 0.28 0.14	
MPlan Apo Plan Achromat (FN26.5)	50X 100X	0.95 1.40	0.3 0.08	0 0	0.35 0.24	500X 1000X	1.04 0.59	1.44 0.22	750X 1500X	0.80 0.47	0.28 0.14	
LMPlan Apo Long working distance plan Semi Achromat (FN26.5)	250X	0.9	0.80	0	0.37	2500X	0.50	0.09	3750X	0.44	0.06	
LMPlan Apo-BD Long working distance plan Achromat (FN26.5)	250X	0.9	0.80	0	0.37	2500X	0.50	0.09	3750X	0.44	0.06	

\*When MPlan-BD objectives are used in combination with the U-ULH lamp housing (mercury burner and xenon socket) for darkfield observation, the peripheral field of view may be insufficiently illuminated depending on the specimen.

# 9 TROUBLESHOOTING GUIDE

Under certain conditions, performance of this unit may be adversely affected by factors other than defects. If problems occur, please review the following list and take remedial action as needed. If you cannot solve the problem after checking the entire list, please contact your local Olympus representative for assistance.

Problem	Cause	Remedy	Page
<b>1. Optical System</b>			
a) Bulb does not light.	Bulb burned out.	Replace bulb.	6
	Fuse burned out.	Replace fuse.	9
b) Bulb operates, but field of view remains dark.	Iris diaphragm is stopped down. (Transmitted light)	Open the aperture and field iris diaphragm sufficiently.	27,28
	Iris diaphragm is stopped down (Reflected light)	Open both aperture and field iris diaphragm, and pinhole diaphragm.	20,21
	Condenser is lowered too much.	Adjust the condenser height position.	27
	Trinocular tube light path selector knob is set to ☐ position.	Move the knob to the ☐ or ☐ position.	26
	The cube is not engaged correctly. (Reflected light)	Engage the cube correctly in the light path.	32
c) Field of view is obscured, or field of view is not evenly illuminated.	Trinocular tube light path selector knob is not positioned correctly.	Fully engage the knob in the desired position.	26
	The revolving nosepiece is not correctly engaged.	Make sure that the revolving nosepiece clicks properly into place.	13
	The revolving nosepiece is not correctly mounted.	Slide the nosepiece along the dovetail as far as it will go, then tighten with screw.	8
	An objective that falls outside of the condenser's illumination range is used.	Use a condenser that matches the objective.	28
	The condenser is not properly centered.	Center the condenser.	27
	The field iris diaphragm is not properly centered.	Center the field iris diaphragm.	20,27
	The field iris diaphragm is stopped down too far.	Open the field iris diaphragm.	20,27
	The filter is not correctly engaged.	Make sure the filter clicks properly into place.	18,21
	The halogen bulb is not mounted correctly.	Push the pins of the halogen bulb fully into the proper pinholes.	6
	Analyzer and polarizer are not engaged correctly.	Engage the analyzer and polarizer correctly in the light path.	33
d) Dirt or dust is visible in the field of view.	Dirt on the base light exit glass.	Clean thoroughly.	—
	Dirt on the top lens of the condenser.		
	Dirt/dust on specimen.		
	Dirt/dust on eyepiece.		
	Dirt/dust on the front lens of the objective.		
e) The image shows diffraction.	Condenser is lowered too far.	Adjust the condenser height position.	27
	The aperture iris diaphragm/pinhole diaphragm is stopped down too far.	Open the diaphragm.	20,27

Problem	Cause	Remedy	Page
f) Visibility is poor. • Image is not sharp. • Contrast is poor. • Details are indistinct.	You are using a non-UIS series objective.	Use only UIS series objectives with this microscope.	38,39
	The revolving nosepiece is not positioned correctly.	Slide the nosepiece along the dovetail as far as it will go, then tighten with screw.	8
	The objective is not correctly engaged in the light path.	Make sure that the revolving nosepiece clicks into place correctly.	13
	The correction collar on the correction collar equipped objective is not adjusted.	While focusing, turn the correction collar to find the best position.	30
	Front lens of the objective is dirty.	Clean the objective.	—
	Immersion oil is not being used with an oil immersion objective.	Use immersion oil.	30
	The immersion oil contains bubbles.	Remove bubbles.	30
	Recommended immersion oil not used.	Used the provided immersion oil.	30
	Specimen is dirty.	Clean.	—
	Condenser is dirty.		
	Inappropriate object slide or cover glass thickness.	Replace with glass of appropriate thickness.	22
g) Part of the image is blurred.	The revolving nosepiece is not properly mounted.	Slide the nosepiece along the dovetail as far as it will go, then tighten with screw.	8
	The objective is not correctly engaged in the light path.	Make sure that the revolving nosepiece clicks into place correctly.	13
	The specimen is not mounted correctly on the stage.	Place the specimen correctly on top of the stage and secure it with the specimen holder.	22,23
h) The image appears to waver.	The revolving nosepiece is not properly mounted.	Slide the nosepiece along the dovetail as far as it will go, then tighten with screw.	8
	The objective is not correctly engaged in the light path.	Make sure that the revolving nosepiece clicks into place correctly.	13
	The condenser is not properly centered.	Center the condenser.	27
i) The field of view becomes only slightly brighter when the voltage is raised.	The condenser is not properly centered.	Center the condenser.	27
	Condenser is lowered too far.	Adjust the condenser height position.	27
<b>2. Electrical System</b>			
a) The bulb intermittently lights and goes out.	The bulb is nearly burned out.	Replace the bulb.	6
	A connector plug is improperly connected.	Check all connections.	7
b) The bulb burns out almost immediately.	Wrong type of bulb used.	Use the correct bulb type.	6
c) Brightness does not change when you move the light intensity lever.	The light preset button is set to ON.	Press the button to OFF.	17
d) The voltage indicator LEDs all light, and are not affected by the light intensity lever.	The halogen bulb is not installed.	Install the halogen bulb.	6
	The bulb is burned out.	Replace the bulb.	6
	The lamp housing power cord is disconnected.	Connect the lamp housing power cord correctly.	7
e) Bulb voltage is not raised even when you slide the light intensity lever upward.	The bulb is burned out.	Replace the bulb.	6

Problem	Cause	Remedy	Page
<b>3. Coarse/Fine Adjustment</b>			
a) The coarse adjustment knob is hard to turn.	The tension adjustment ring is tightened excessively.	Loosen the ring.	29
	Your are trying to raise the stage with the coarse adjustment knob with the pre-focusing lever locked.	Unlock the pre-focusing lever.	29
b) The stage drifts down by itself, or focus is lost during observation.	The tension adjustment ring is too loose.	Tighten the ring.	29
c) The image is not focused.	When adjusting the stage height, you forgot to reattach the upper stopper screw.	Reattach the upper stopper screw.	24
d) Coarse adjustment will not go all the way up.	The pre-focusing lever is keeping the stage down.	Unlock the pre-focusing lever.	29
e) Coarse adjustment will not go all the way down.	The condenser holder is too low.	Raise the condenser holder.	27
f) The objective makes contact with the specimen before focus is obtained.	The specimen is mounted upside-down.	Mount the specimen correctly.	—
<b>4. Observation Tube</b>			
a) Field of view of one eye does not match that of the other.	The interpupillary distance is incorrect.	Adjust the interpupillary distance.	25
	Incorrect diopter adjustment.	Adjust the diopter.	25
	Different eyepieces are used on the left and right.	Change one eyepiece to match the other so that both sides are the same.	—
	The optical axes are not parallel.	Upon looking into the eyepieces, try looking at the overall field before concentrating on the specimen range. You may also find it helpful to look up and into the distance for a moment before looking back into the microscope.	—
<b>5. Stage</b>			
a) The image shifts when you touch the stage.	The stage is not properly mounted.	Clamp the stage.	3
b) Specimen stops midway on the X-axis traverse.	The specimen is not correctly positioned.	Place the specimen correctly.	22,23
c) The X-axis and Y-axis knobs are too tight, or too loose.	Is X-axis or Y-axis tension too high or too low?	Adjust the tension.	23

This device complies with the requirements of both directive 89/336/EEC concerning electromagnetic compatibility and directive 73/23/EEC concerning low voltage. The CE marking indicates compliance with the above directives.