

Freedom to explore

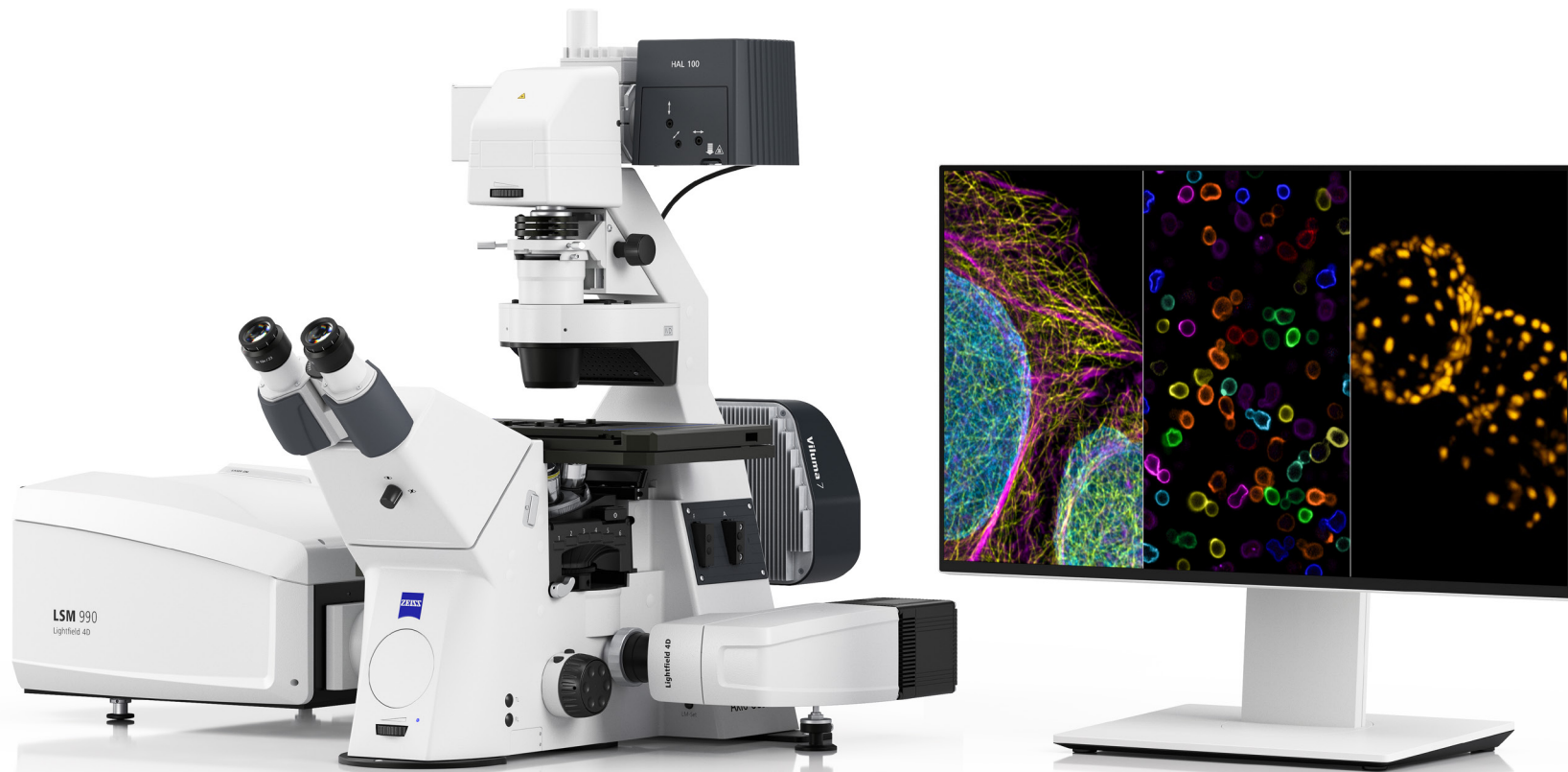

ZEISS LSM 990

Top-Class Multimodal Imaging Combined in One Confocal System

zeiss.com/lsm-990



Seeing beyond

Freedom to explore

Top-class multimodal imaging combined in one confocal system

- › In Brief
- › The Advantages
- › Technology Insights
- › The System
- › Technical Specifications
- › Service

ZEISS LSM 990 invites you to embark on an extraordinary journey of scientific discovery, where imaging transcends traditional boundaries. This top-class confocal microscope comes with an unprecedented range of multi-modal imaging options – all combined in one system to help you reveal new dimensions of your research.

With super-resolution imaging down to 90 nm and instant volume acquisition of high-speed biological processes at 80 volumes per second, you can delve into the depths of your biology with clarity and precision. Unlock the full spectrum of possibilities utilizing an emission wavelength range of 380 to 900 nm and separate over 10 fluorescent labels in one go – to allow every one of them to tell its own story. Explore deeper with multiphoton excitation.

But don't stop at mere image acquisition. ZEISS LSM 990 is your key to understanding molecular dynamics, protein interactions, and physiological processes. Whether you're investigating flow in microfluidic systems or studying complex protein behaviors, this system empowers you to push the limits of live imaging and experimental design.

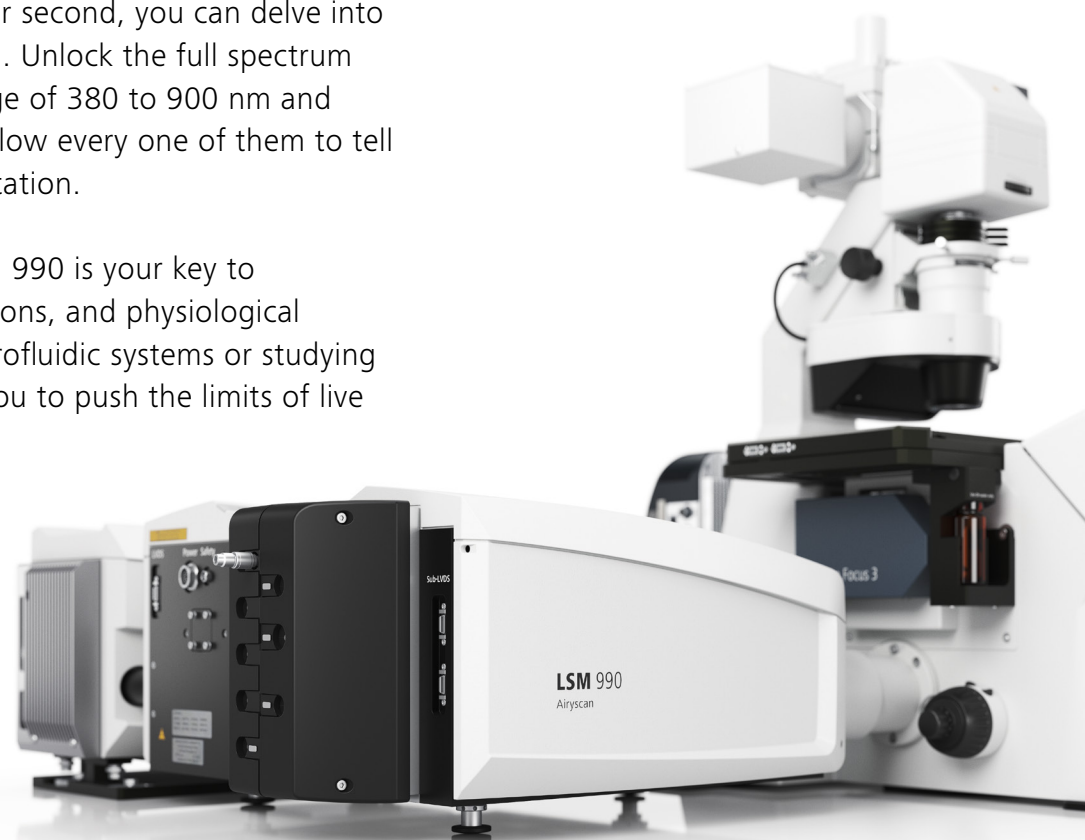



Beyond confocal

A wealth of possibilities for your research

- › **In Brief**
- › The Advantages
- › Technology Insights
- › The System
- › Technical Specifications
- › Service

Confocal microscopes have become synonymous with advanced optical sectioning and maximum imaging flexibility – no other microscope can accommodate such a variety of samples and experiments.

ZEISS LSM 990 takes this versatility to the next level, combining high-speed super-resolution, unparalleled instant volume acquisition, superior depth penetration, and on-the-fly spectral separation of 10 labels in a single image scan. Additionally, integrating photomanipulation or measurements of molecular dynamics enable discoveries that extend beyond mere fluorescence intensity imaging.

All system components, in particular Airyscan 2, Lightfield 4D and up to 36 spectral detectors, have been developed to enable best-in-class live imaging. Unleash your creativity in experimental design and advance your scientific exploration!

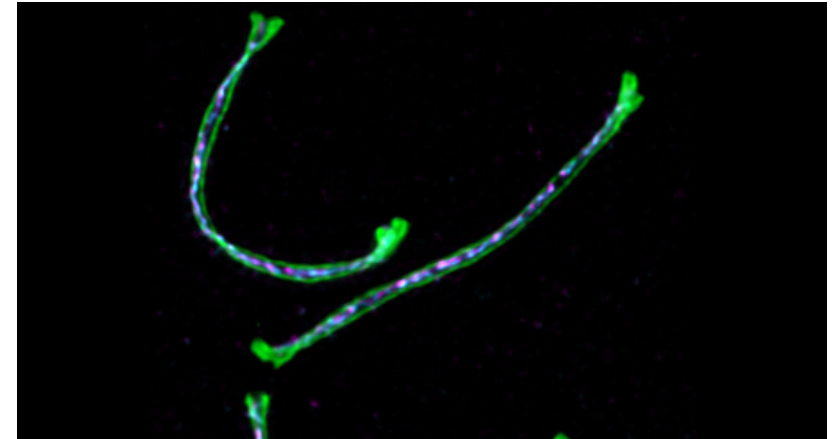

Airyscan: Super-resolution imaging of the synaptonemal complex with clearly resolved tripartite structure. Courtesy of Suixing Fan, University of Science and Technology of China

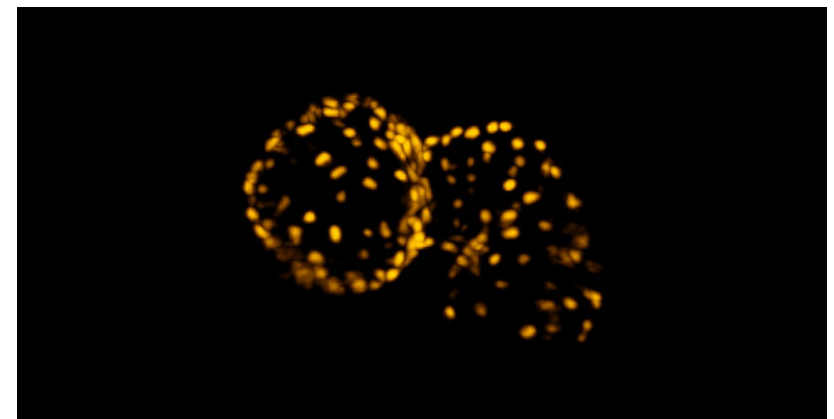

[▶ Click here to view this video](#)

Lightfield 4D: Instant volumetric imaging of a beating embryonic zebrafish heart at 3 days post fertilization (80 volumes per second). Courtesy of Stone Elworthy and Emily Noël, School of Biosciences, University of Sheffield, UK



Beyond spectral limitations

Fluorescence imaging as colorful as life itself

› In Brief

› The Advantages

› Technology Insights

› The System

› Technical Specifications

› Service

The identification and reliable separation of fluorescent labels are fundamental to every multi-color experiment, even more as the choice of dyes has expanded well into the near-infrared (NIR) range, and biomarker collections for spectral multiplexing enable even more structures to be simultaneously identified.

With up to 36 channels, ensuring optimal quantum efficiency for each wavelength, a total emission range from 380 nm to 900 nm can be acquired with a single image scan. Select the desired detection range for each label to enhance your results or utilize all channels within the required emission range to gather comprehensive spectral information of every fluorophore in every single scan.

For highest productivity during multi-dimensional experimental acquisition, spectral unmixing occurs on-the-fly while LSM Plus enhances signal-to-noise ratio and resolution within the same processing pipeline.

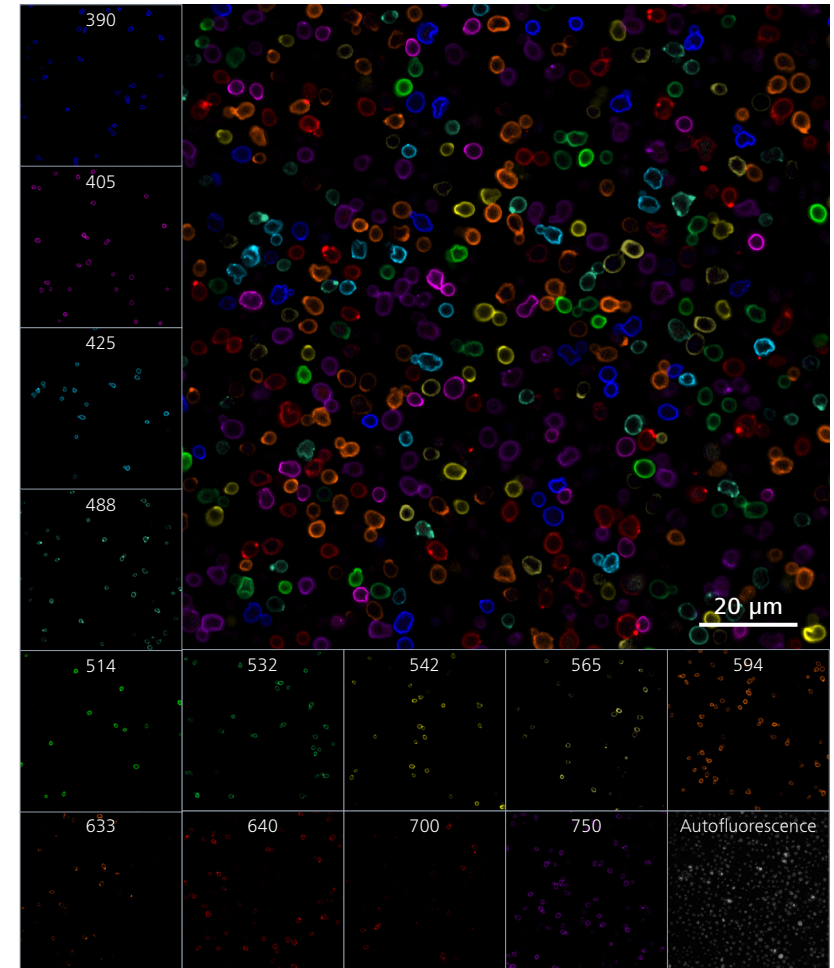

Advanced spectral multiplexing of yeast cells: 13 labels plus autofluorescence acquired in one track using 5 lasers and 36 detectors; image data processed with LSM Plus; channels after spectral unmixing



Beyond imaging

Unique insights into molecular dynamics and protein interactions

› In Brief

› The Advantages

› Technology Insights

› The System

› Technical Specifications

› Service

Go beyond fluorescence imaging and add new dimensions to your experiments.

Employ Fluorescence Correlation Spectroscopy (FCS) and Spectral RICS to gain insights into protein concentrations, movement, and interactions for multiple labels simultaneously. With spatial information from the Airyscan detector, you get unique access to the molecular behavior of proteins, providing insights into blood flow or dynamics within microfluidic systems, such as organ-on-a-chip setups.

Additional fluorophore characteristics captured with Fluorescence Lifetime Imaging Microscopy (FLIM) enable the investigation of physiological processes and extend the capabilities of your LSM to obtain information on protein-protein interactions and environmental parameters such as pH, oxygen, or iron concentration.

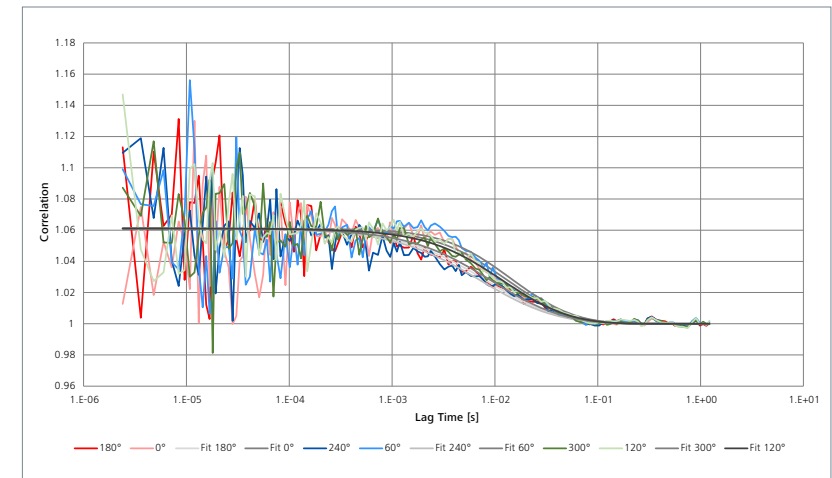
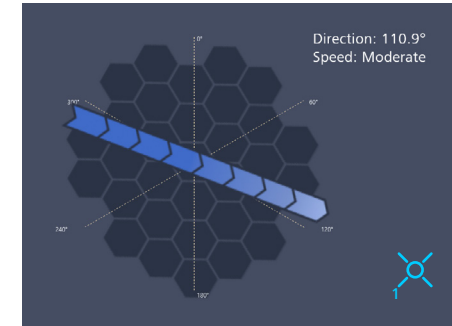
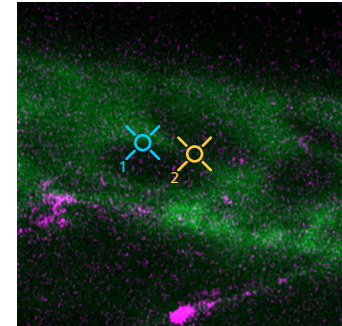

Dynamics Profiler: Direction and speed of molecule flow through the blood vessel of a zebrafish larvae were measured at two different spots (top). The graph (bottom) shows the correlation curves of the measurement within spot 1: actual flow speed and direction results out of the 6 cross-correlations along three axis. Courtesy of V. Hopfenmüller, Leibniz Institute on Aging – Fritz Lipmann Institute (FLI), Germany

The ZEISS LSM 990 product family

Shape your high-end imaging platform

- › In Brief
- › **The Advantages**
- › Technology Insights
- › The System
- › Technical Specifications
- › Service

Your ZEISS LSM 990 can be configured in many different ways depending on your imaging requirements, from a pure confocal system to an imaging platform that integrates all available modalities. If you want to utilize specific strengths for your most demanding applications, we recommend choosing one of the following configurations – or combine them to your needs.

LSM 990 Airyscan

Sensitive super-resolution imaging and molecular characterization



LSM 990 Airyscan enables experiments that push the boundaries of gentle super-resolution, high-speed acquisition, and molecular characterization of biological samples. By maximizing signal detection through the utilization of its unique area detector, Airyscan achieves a distinctive blend of sensitivity and enhanced spatial information. As a user-friendly technology that is fully integrated into ZEISS laser scanning microscopes, it offers you ever-evolving possibilities to go beyond traditional confocal imaging.

LSM 990 Spectral Multiplex

Multi-fluorescence imaging along the entire wavelength range



LSM 990 Spectral Multiplex excels in the spectral separation of fluorescent labels. Optimize your advanced spectral multiplexing experiments with numerous protein markers and clear separation of fluorescence signals while reliably eliminating autofluorescence. Become more productive with a system that facilitates optimal imaging conditions, immediate dye identification, and streamlined workflows from acquisition to analysis.

LSM 990 Lightfield 4D

Instant volumetric high-speed imaging of living organisms



Employ light-field microscopy for instant volumetric imaging to study the dynamics of organisms at up to 80 volumes per second – with all spatio-temporal information intact. Acquire thousands of volumes over time without harming your living sample. Capture multiple positions of organisms, organoids or spheroids in a single run. Combine this unique one-snap-one-volume acquisition with any other imaging mode of your ZEISS confocal.

More information:

[Explore the ZEISS LSM product family](#)



Microscopy Copilot

Interactively discover new approaches for your experiments.



- › In Brief
- › **The Advantages**
- › Technology Insights
- › The System
- › Technical Specifications
- › Service

The Microscopy Copilot, your personal AI assistant, helps you to interactively discover new possibilities for your imaging experiments. Ask questions when they are relevant to your current work. Reduce training time by getting new information straight away. Constantly evolve your research and exploit the potential of your specific LSM system configuration.

Microscopy Copilot

Microscopy Copilot Your personal AI assistant is here to support you.

Hello, I am your personal AI assistant, here to support your microscopy work.

Well, how exactly can you assist me?

I have access to an extensive library of information about microscopy, particularly laser scanning microscopy. If you ask me a question, I can gather and summarize information from various sources. My large language model provides responses that match the type of your inquiry.

But what if the information doesn't align with my system configuration? Wouldn't that be a waste of my time?

I can see your current microscope configuration and the available software. This allows me to consider the specific equipment you have at your disposal. Together, we can explore the options that this specific system has to offer.

And if you can't find an answer?

I can acknowledge when I lack sufficient information and will inform you accordingly. My knowledge base is continuously updated, which means I will improve and learn over time. But for the moment, feel invited to explore the capabilities of your LSM 990 – simply flip through the pages of this document :-).

ZEISS LSM 990 at work

- › In Brief
- › **The Advantages**
- › Technology Insights
- › The System
- › Technical Specifications
- › Service

The essence of confocal imaging

High-resolution optical sectioning of large samples



Three-day-old primary mouse organoid. Secretory cells of the small intestine produce holes in the apical f-actin brush border. Dapi (white): DNA, phalloidin (green): f-actin, UEA-1 (red): Secretory cells (Paneth, goblet), COX-1 (violet): Tuft cell. Courtesy of Fabian Gärtner, University of Stuttgart, Germany

Multiphoton microscopy

Recovering information from deep within tissue

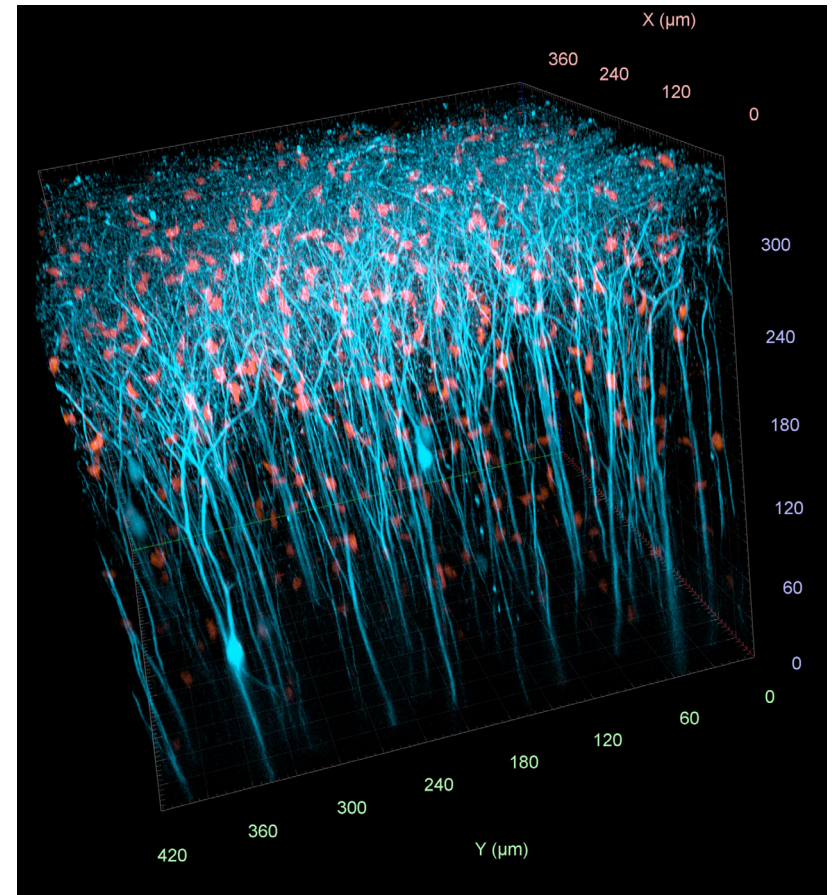

Pyramidal neurons (YFP-H) and microglia (CxCR3-GFP) imaged in whole mouse brain. Courtesy of Severin Filser, DZNE Bonn, Germany

ZEISS LSM 990 at work

› In Brief

› **The Advantages**

› Technology Insights

› The System

› Technical Specifications

› Service

Advanced spectral imaging

In-depth understanding of spatial biology

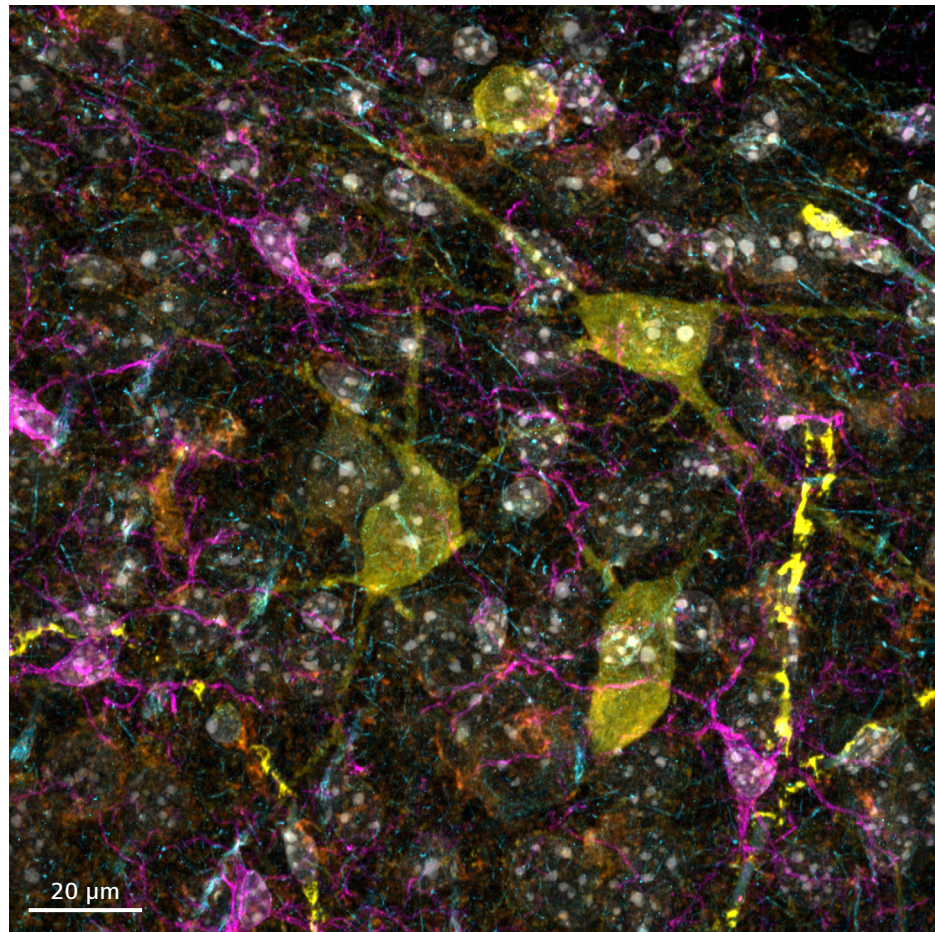

5-color brain slice sample acquired through a Lambda scan and processed with LSM Plus. Channels after spectral unmixing: DAPI, Map2-A488, Parvalbumin-A568, Iba-1-A647, VGAT-A750, Autofluorescence

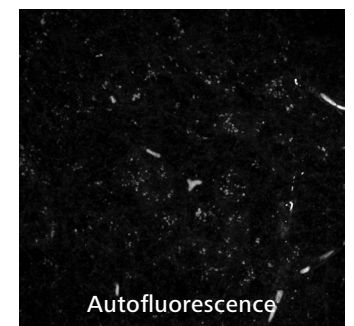
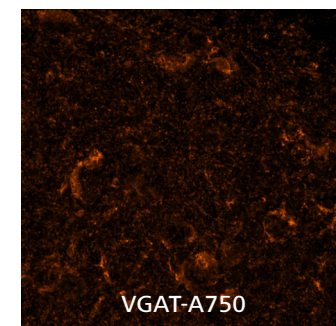
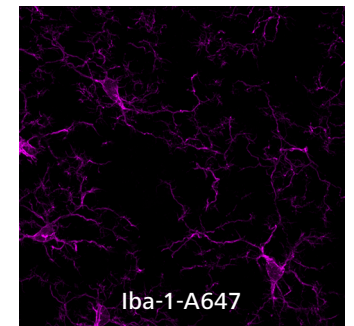
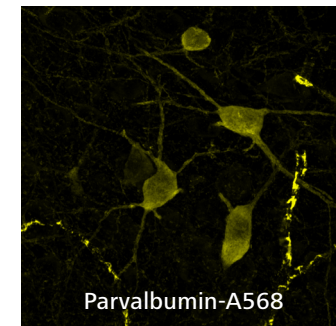
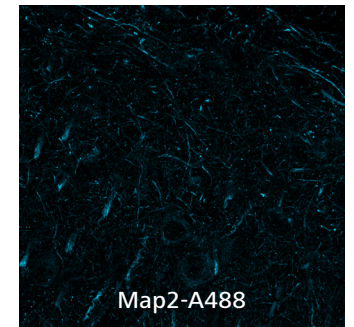
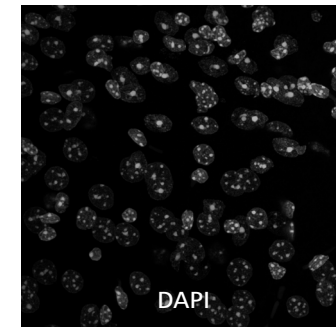

ZEISS LSM 990 at work

- › In Brief
- › **The Advantages**
- › Technology Insights
- › The System
- › Technical Specifications
- › Service

Lightfield 4D

Gentle, high-speed volume acquisition of highly mobile cells in developing animals

Visualizing development of tissues and organs in 3D in intact animals enables better understanding of factors involved in their regulation and dysfunction.

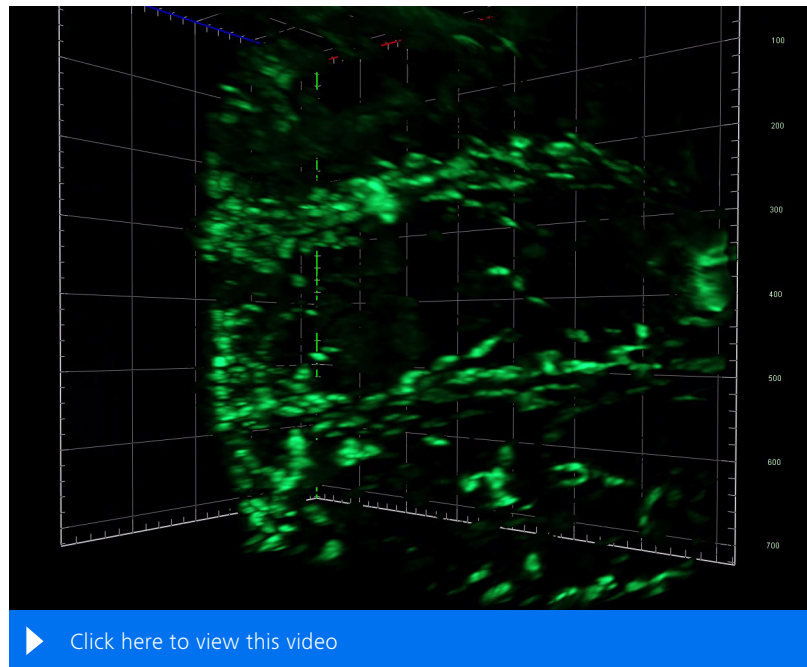

Fat body progenitor cell migration in a developing Drosophila pupa. The data was recorded from a de-cased 58h-old Drosophila melanogaster pupa expressing cD8::eGFP in the progenitor cells of the adult fat body using the driver OK6-Gal4;Elav-Gal80. The overnight experiment imaged 12 positions with a 20x objective with 500 ms per volume imaged every 2 minutes for 15 hours. Courtesy of Ignacio Manuel Fernández Guerrero, Cellular Analysis Facility, MVLS-Shared Research Facilities, University of Glasgow.

Lightfield 4D

Efficient imaging of organoids and spheroids

Fast volume acquisition of cleared spheroids enables 3D screening applications with increased throughput. Cellular resolution is sufficient to count individual cells/nuclei.

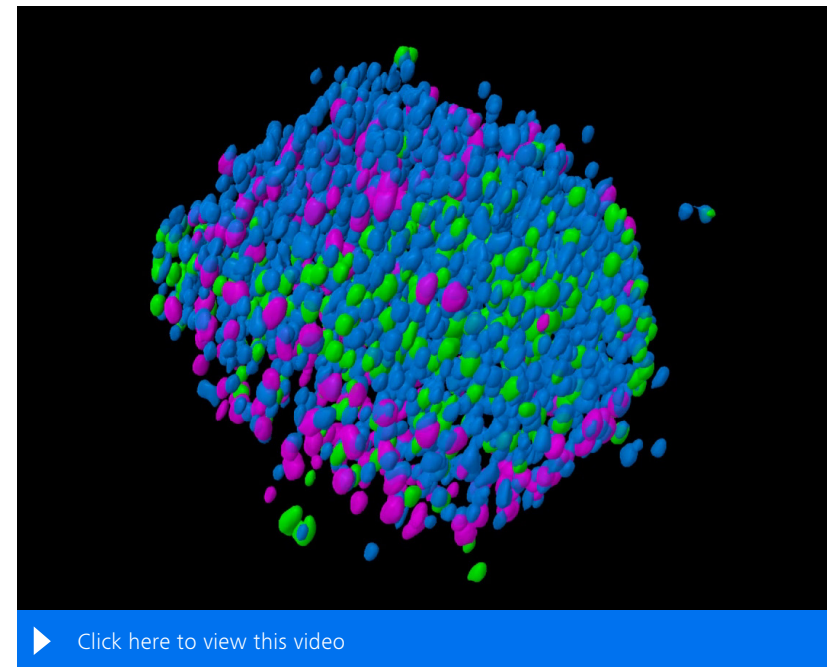

Cleared spheroid of a co-culture of HCT-116-GFP (colon cancer) / NIH-3T3-RFP (fibroblasts) cells stained with Hoechst for nuclei. Imaged in an InSphero Akura plate. Dataset was segmented using arivis Pro. Sample courtesy of InSphero AG. Schlieren, Switzerland

ZEISS LSM 990 at work

- › In Brief
- › **The Advantages**
- › Technology Insights
- › The System
- › Technical Specifications
- › Service

Airyscan SR

Gentle super-resolution imaging of the smallest structures

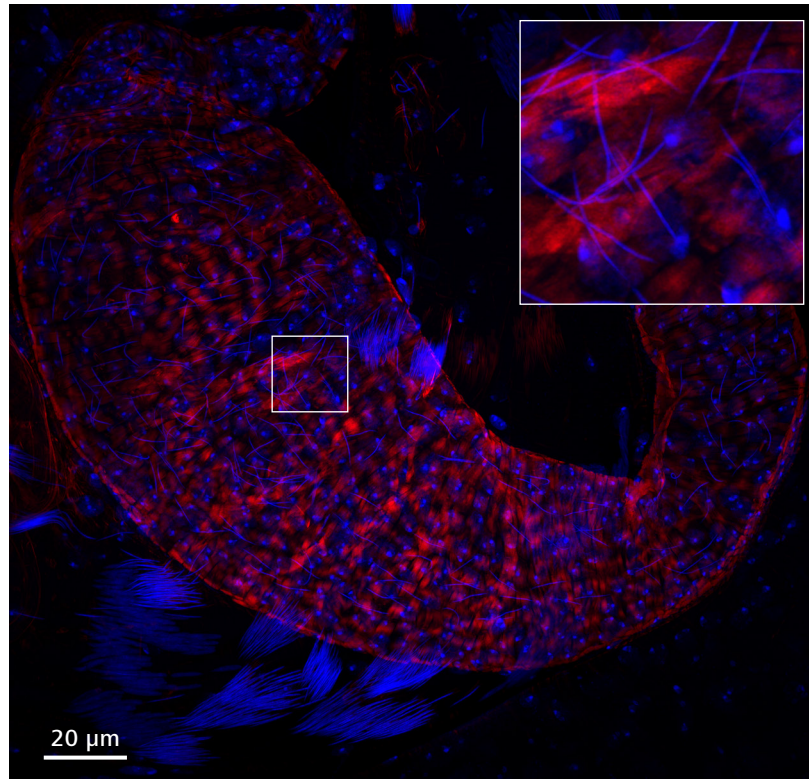

Sperm flagella in *Drosophila* testes. DAPI for DNA (showing nuclei and sperm), F-Actin labelled with phalloidin. Maximum intensity projection of a 54-slice stack
Sample courtesy of Zhaoxuan Zhang, Ocean University of China, Qingdao

Airyscan Multiplex

Efficient super-resolution imaging through parallelization

High-resolution, rapid volumetric imaging with gentle illumination is essential for studying vesicular transport in living cells. The unique combination of the gentle illumination provided by the Airyscan technology and its high-speed capabilities enables effective imaging of vesicle movement in 3D.

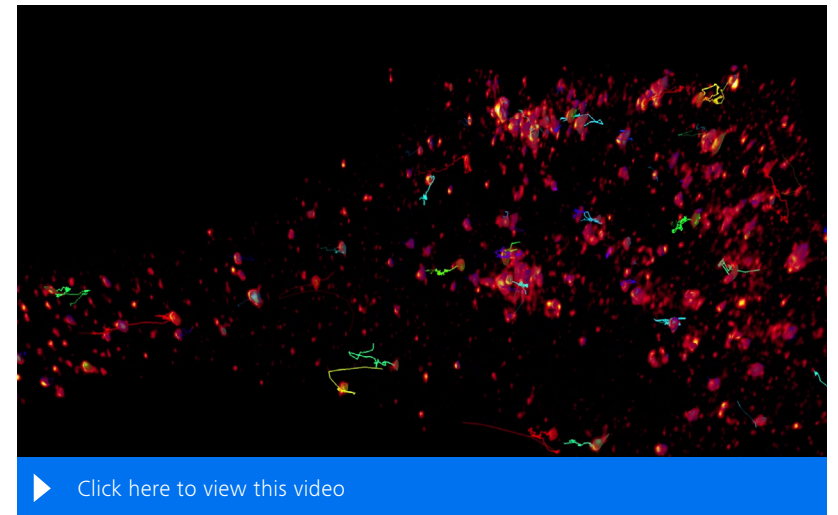

Fast movement of early endosomes in mammalian cells, acquired with Airyscan 2 using the MPLX CO-8Y mode. Thanks to the resolution improvement with Airyscan jDCV, the vesicles could be segmented and tracked with ZEISS arivis Pro through the cellular volume in time.

ZEISS LSM 990 at work

- › In Brief
- › **The Advantages**
- › Technology Insights
- › The System
- › Technical Specifications
- › Service

Spectral RICS

Uncovering the true behavior of proteins in living cells

Effects of SUMOylation in protein diffusion: RICS can be used to measure changes in diffusion resulting from protein interaction. With standard auto-correlation RICS analysis, we can see that the diffusion coefficient drops in correspondence with the size of SUMO chain. This type of studies can also measure the changes in diffusion of tagged proteins of interest in the presence of drug treatments, mutations, or other influences.

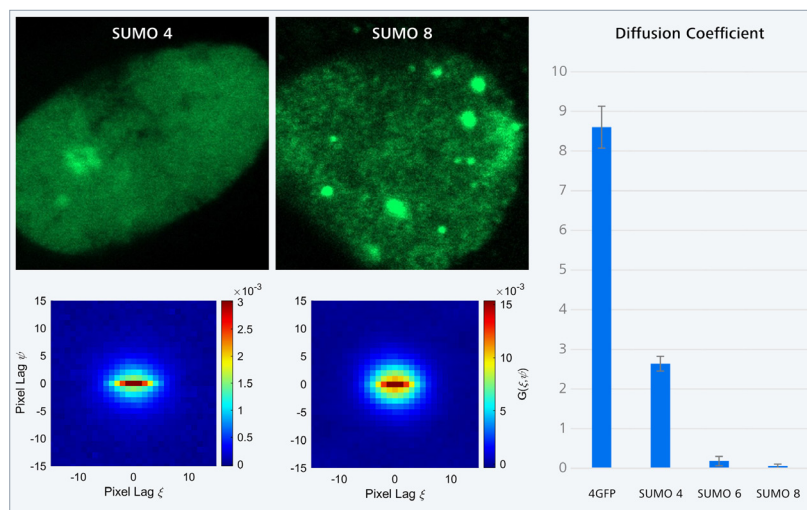

Samples kindly provided by P. Hemmerich and T. Ulbricht, Core Facility Imaging, Leibniz Institute on Aging, Jena, Germany

Fluorescence Lifetime Imaging Microscopy (FLIM)

Functional imaging using differences in fluorescence decay

FLIM takes into account how fluorescence lifetime can be influenced by factors such as ion or oxygen concentration, pH, and temperature. FLIM is beneficial for analyzing proximity of and interaction between molecules.

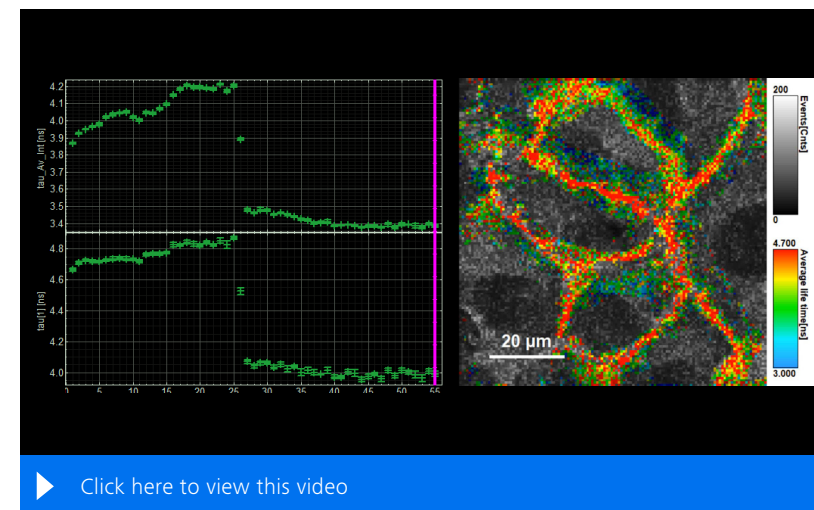

U2OS cells stained with Flipper-TR. Right: Color shows fluorescence lifetime after fitting. Left: Time plot of fitted fluorescence lifetimes with standard deviations for Tau average and Tau1. Fluorescence lifetime differences smaller than 100 ps can be measured. Sample courtesy of Dr. Sarah Woolner, University of Manchester, UK.

ZEISS LSM 990 at work

- › In Brief
- › **The Advantages**
- › Technology Insights
- › The System
- › Technical Specifications
- › Service

ZEISS arivis Pro

From simple 3D visualization to advanced segmentation, tracking, and data analysis

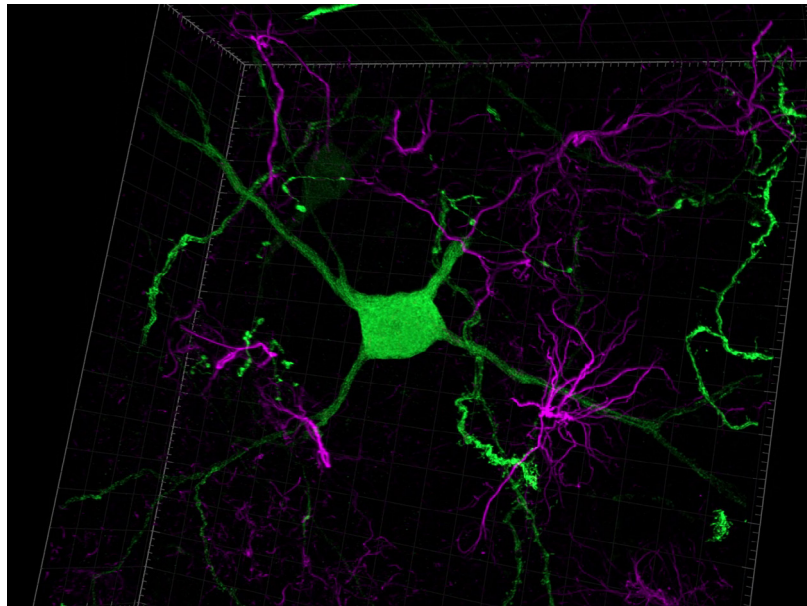

▶ [Click here to view this video](#)

Neurons and astrocyte in thick brain sections imaged with Airyscan MPLX 4Y mode and rendered with ZEISS arivis Pro. Spines and other details of neuron morphology are visible. Sample courtesy of Luisa Cortes, Microscopy Imaging Center of Coimbra, CNC, University of Coimbra, Portugal

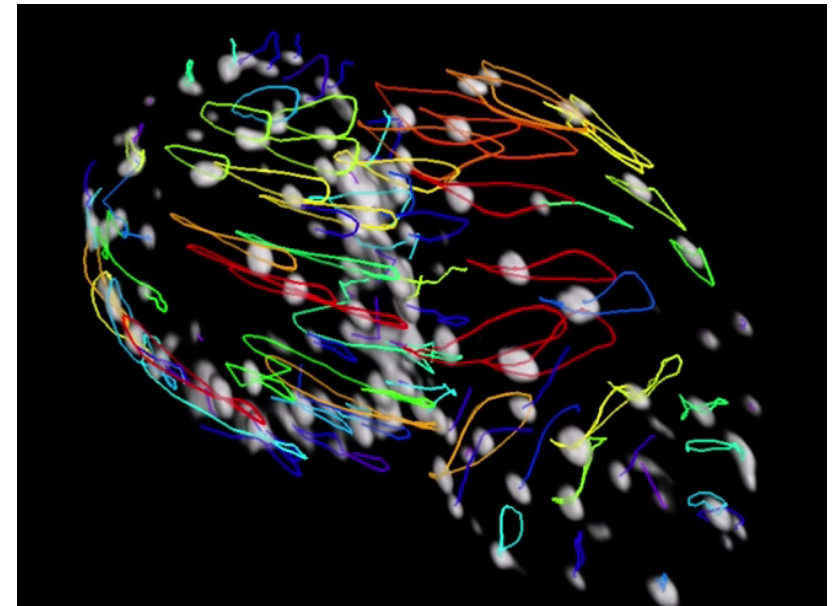

▶ [Click here to view this video](#)

Investigating the morphology and cardiac wall movement of the developing zebrafish heart: Beating embryonic zebrafish heart at 3 days post fertilization, cardiomyocyte nuclei labelled with mCherry. Lightfield 4D acquisition of 3 full heartbeats in 1.2 seconds, during which cardiomyocytes are temporally and spatially resolved. This allows for cell segmentation and tracking using arivis Pro. It is clearly visible that the cardiomyocytes follow exactly the same trajectory in every heartbeat.

Beam path design and detector architecture

Advanced light preservation, sensitivity, and spectral capabilities

- › In Brief
- › The Advantages
- › **Technology Insights**
- › The System
- › Technical Specifications
- › Service

Beam path

The LSM 990's advanced beam path design, high-bandwidth electronics, and premium optics ensure high levels of light preservation, visualization of a high dynamic range, and a broad wavelength bandwidth. These properties enable quality image acquisition of a large variety of samples and structures, their molecular characteristics, and highly multiplexed spectral information.

Effective scanner movement allows more than 85% of frame time for signal collection, while linear galvo scanners provide equal time contribution to each pixel for all scanning speeds, essential for quantitative imaging and advanced applications like Spectral RICS. The low-angle Twin Gate beam splitter directs excitation laser light to the sample and efficiently separates it from the emission signal, preventing laser reflection light in your images. After passing through the apochromatic pinhole, the emission signal is spectrally separated at the holographic grating, and the recycling loop efficiently directs photons to the Quasar detection unit, which allows you to define emission bands matching your used fluorophores.

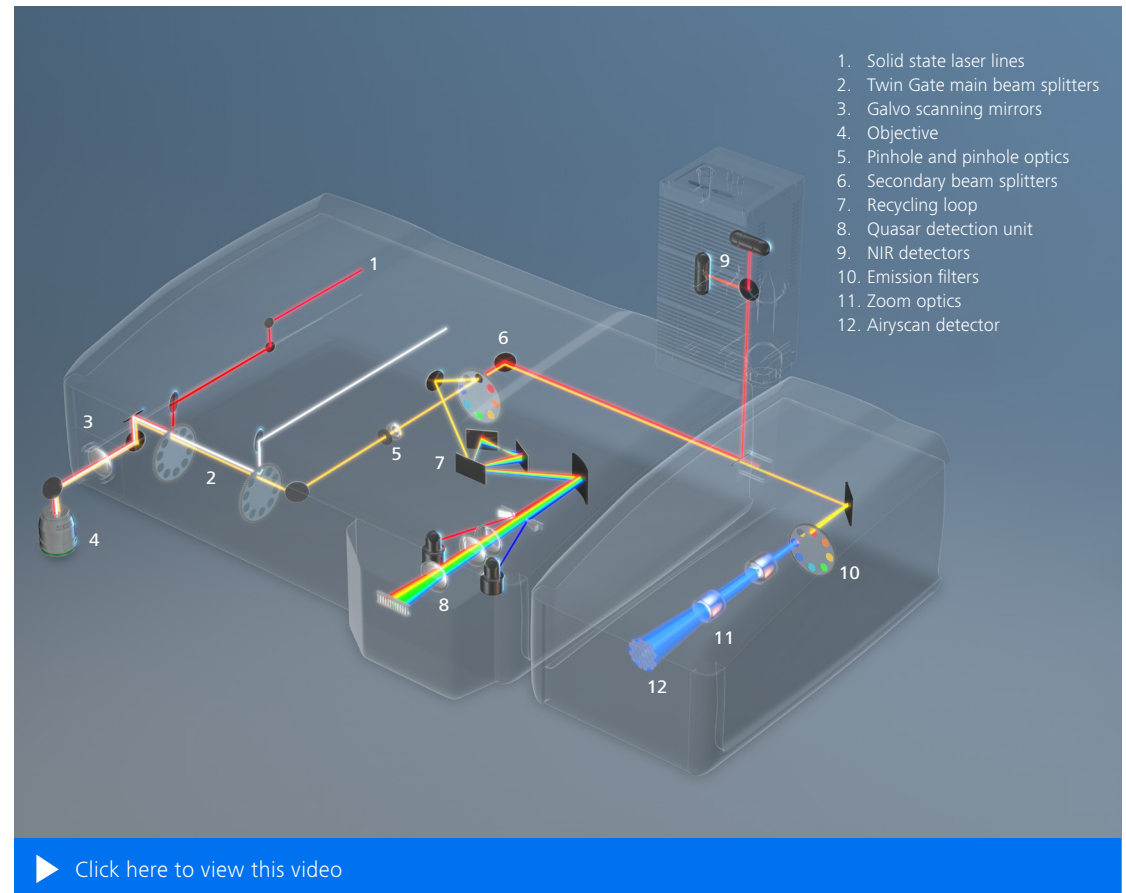

▶ [Click here to view this video](#)

Beam path of LSM 990: Emission light travels through the Twin Gate main dichroic beam splitter with its very efficient laser suppression to deliver supreme contrast. Then, at the secondary beam splitter, the emission light either travels to the internal spectral detection unit (Quasar) with 3, 6, or 34 channels and to the NIR detector. Or, light is sent to the Airyscan 2 area detector with GaAsP technology.

Beam path design and detector architecture

Advanced light preservation, sensitivity, and spectral capabilities

- › In Brief
- › The Advantages
- › **Technology Insights**
- › The System
- › Technical Specifications
- › Service

LSM 990 brings a great deal of freedom to your experimental setup. Every single component is optimized to deliver the highest sensitivity and spectral flexibility for your experiments—the perfect starting point for improving all your confocal images with LSM Plus, increasing SNR without adding time or laser light to your experiment.

Detectors

LSM 990 can be equipped with a 32-channel GaAsP detector, complemented by two side detectors and two optional NIR GaAs and GaAsP detectors. This unique configuration provides the highest number of detectors available in LSM systems. For multi-label experiments, each fluorescent label's emission range is captured using the most suitable detector technology.

To ensure that no photon is falling through the gaps, the 32-channel Quasar unit is equipped with microlenses to focus light onto the active detector surface. All GaAsP or GaAs detectors can operate in analog or photon counting mode, adapting to varying sample and experimental needs. For truly gentle and quantifiable imaging, the laser power can be controlled in a linear manner down as low as 0.001 % of its total capacity.

Fluorescent labels with emission spectra ranging from 380 nm to 900 nm can be included in an experiment. Smart Setup helps determine the best solid-state laser lines for excitation and the most efficient detectors for wavelengths up to 900 nm.

To separate overlapping signals from multiple labels or remove unwanted autofluorescence, a Lambda Scan can be performed using up to 36 detectors, truly simultaneously. Advanced linear unmixing options enable instant separation of labels based on reference spectra (Online Fingerprinting) or through a processing pipeline that retains raw data and quality control channels.

This pipeline can include LSM Plus processing to enhance signal-to-noise ratio and resolution of spectrally separated labels, aiding in precise spatial phenotyping and accurate location of biomarkers.

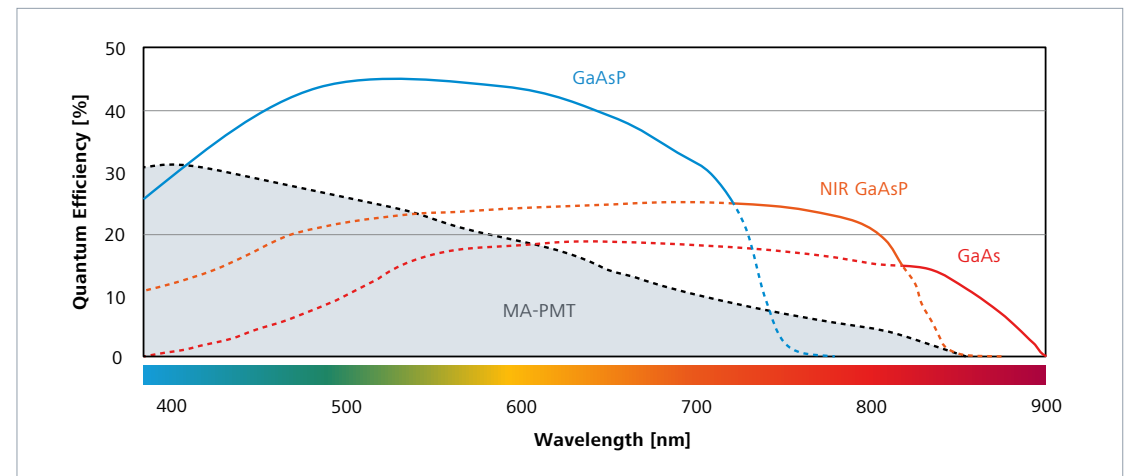

Typical spectral quantum efficiency (QE) of ZEISS LSM 990 detectors

LSM Plus

Improving the confocal experience

- › In Brief
- › The Advantages
- › **Technology Insights**
- › The System
- › Technical Specifications
- › Service

LSM Plus improves any confocal experiment with ease, independent of detection mode or emission range. Its linear Wiener filter deconvolution needs next to no manual interaction while still ensuring a reliable quantitative result.

The system's underlying optical property information such as objective lens, refractive index, and emission range is used to automatically adapt processing parameters for best results.

Apply LSM Plus or add it into your Direct Processing workflow and benefit from:

- **Enhanced signal-to-noise ratio** at high acquisition speeds and low laser powers—particularly useful for live cell imaging with low expression levels
- **Improved spatial resolution** of all acquired data, particularly spectral data taken with up to 36 channels in a single scan or multiphoton data acquired using non-descanned detectors (NDDs)
- **More spatial information** and even greater resolution enhancement for bright samples, enabling reduction of the pinhole size
- **Integrated workflows** to combine the advantages of LSM Plus with Airyscan super-resolution imaging

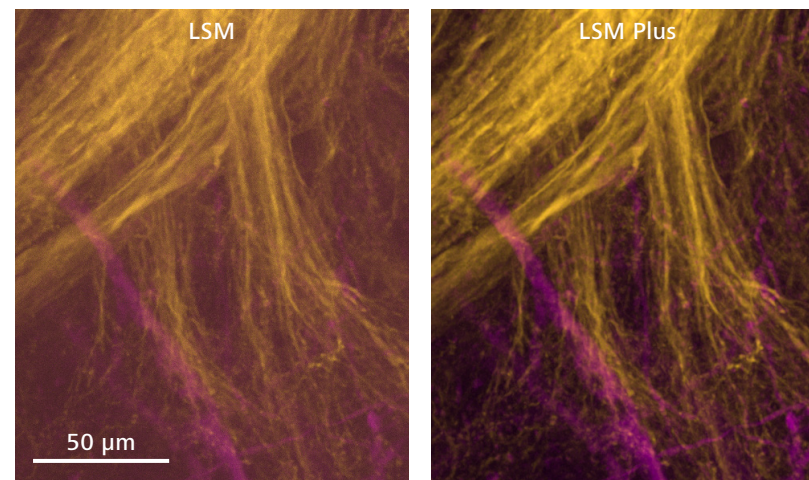

Cockroach brain neurons (Alexa 488: yellow, Alexa 647: magenta) without (left) and with LSM Plus (right). Sample courtesy of M. Paoli, Galizia Lab, University of Konstanz, Germany

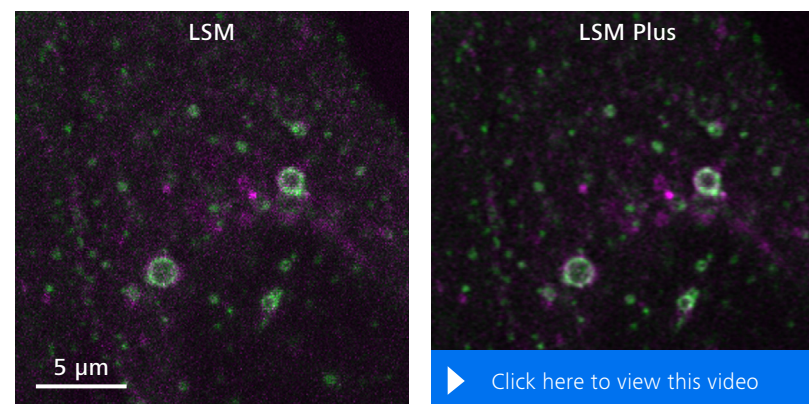

Live cell imaging experiment of U2OS cells with Rab4a:mCherry and Rab5:mEmerald without (left) and with LSM Plus (right).

Airyscan 2

Experimental possibilities beyond confocal standards

- › In Brief
- › The Advantages
- › **Technology Insights**
- › The System
- › Technical Specifications
- › Service

More information:

LSM Airyscan

Experimental possibilities
beyond confocal standards



Airyscan takes the confocal idea beyond its conventional implementation: Instead of light passing through a pinhole to reach a single detector, Airyscan consists of 32 detector elements that act as very small pinholes, taking a pinhole-plane image at every scanned position. By combining 32 such small pinhole-like detectors into a large area detector, Airyscan allows more light to be collected and higher spatial frequency information of a structure to be captured. Its fully integrated linear Wiener filter deconvolution needs next to no interaction while ensuring reliable quantitative results.

Airyscan SR: Gentle super-resolution imaging

With Airyscan, you capture more structural information and collect the available fluorescence signal more efficiently, which makes this super-resolution method particularly gentle for your delicate samples. Choose from a variety of processing options and easily customize them to get reliable and quantifiable data. Lateral resolution down to 90 nm is made possible by Joint Deconvolution – utilizing the additional information that only Airyscan can provide.

Airyscan Multiplex: Productivity through parallelization

In the Multiplex modes, adapted illumination and readout schemes give you a choice of different parallelization options to speed up your super-resolution acquisition. The shape of the excitation beam can be stretched to cover up to 8 image lines simultaneously, allowing for highly parallel signal acquisition. The area detector elements provide all the information needed to improve final image resolution while reducing imaging time dramatically.

Airyscan jDCV: More information from all Airyscan imaging modes

Each of the 32 Airyscan detector elements has a slightly different view on the sample, providing additional spatial information that makes Joint Deconvolution possible for all Airyscan imaging modes. The distance between objects that can be resolved is reduced even further—down to 90 nm, without changing anything during sample preparation or the image acquisition processes. Your super-resolution experiments will benefit from an improved separation of single or multiple labels.



Mitochondria in an *Arabidopsis thaliana* cell. Comparison of confocal image with Airyscan SR and Airyscan jDCV. Courtesy of J.-O. Niemeier, AG Schwarzländer, WWU Münster, Germany

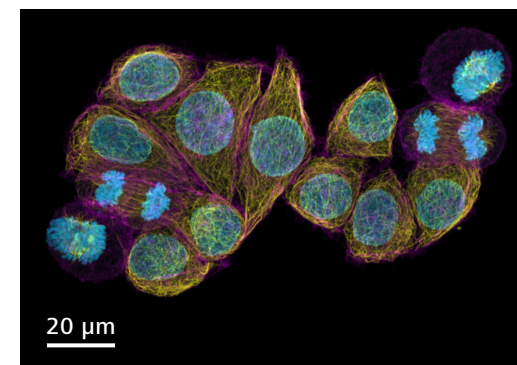

HeLa cells imaged with ZEISS Airyscan 2 in Multiplex mode for efficient super-resolution imaging of a large field of view. Courtesy of A. Politi, J. Jakobi and P. Lenart, MPI for Biophysical Chemistry, Göttingen, Germany

Dynamics Profiler

Your easy access to underlying molecular dynamics in living samples

- › In Brief
- › The Advantages
- › **Technology Insights**
- › The System
- › Technical Specifications
- › Service

More information:

Dynamics Profiler

Add a new dimension to live imaging



Molecular data offers new, and often overlooked, insights about living samples. Fluorescence Correlation Spectroscopy (FCS) is an established method to investigate molecular characteristics. While a precise and very sensitive method, traditionally it is limited to extremely low expression levels or molecule concentrations that can be well below the experimental expression levels in live research samples.

Airyscan uniquely employs all its detector elements to collect 32 individual FCS intensity traces per measurement. The mean value of the inner 19 elements provides robust and reliable measurements on molecular concentration and dynamics, even for bright samples.

Moreover, the area detector allows a variety of spatial cross-correlation analyses by using combinations of single detector elements. Asymmetric diffusion analysis is calculated by cross correlating the center element of the detector with the elements of the outer rings, uncovering heterogeneous characteristics within one excitation volume, perfect to investigate samples such as cellular condensates. Cross-correlation of detector pairs that are grouped and aligned in multiple directions along the excitation volume can measure speed and direction of actively moved molecules, such as fluorophores in microfluidic systems or within the bloodstream.

Furthermore, raw data of all 32 detector elements is saved with every single measurement, enabling you to perform your customized analysis as needed, either immediately or when the scientific question arises later.

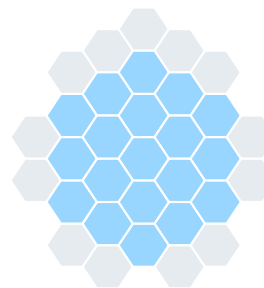

Molecular concentration and diffusion data are collected with the innermost 19 elements of the Airyscan detector. The read-out of separate detectors permits measurements at much higher total intensities (brightness) than conventional FCS would allow.

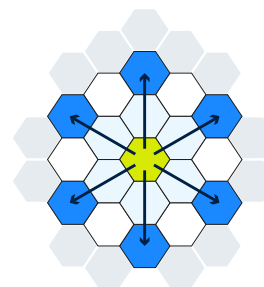

To measure asymmetric diffusion, single Airyscan detector elements of the third ring are cross-correlated with the center element. Polar heatmaps visualize asymmetric diffusion behavior within a measurement spot.

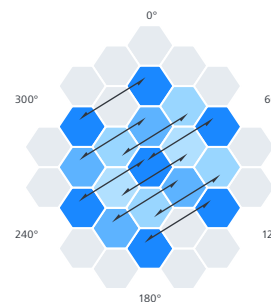

To determine the flow direction and speed within a liquid, a total of 27 detector element pairs are cross-correlated along 3 different axes of the Airyscan detector.

Lightfield 4D

Instant volumetric high-speed imaging of living organisms

- › In Brief
- › The Advantages
- › **Technology Insights**
- › The System
- › Technical Specifications
- › Service

To truly capture the essence of biological processes, imaging must be done in 4D, as both volume and time are essential for investigating living systems. Lightfield 4D offers a unique solution by imaging an entire volume at an exact point in time, without any time delay. Instead of capturing single 2D images at different time points, a micro lens array positioned in between objective and camera generates 37 individual images, collecting all of the 3D information at the same instant. Each of these different views provides both spatial and angular information which serves

as the foundation for creating a Z-stack through deconvolution-based processing. In this way, Lightfield 4D can generate 80 volume Z-stacks per second.

In addition to the uniquely high speed of volume acquisition, this method is notably gentle on living samples. By utilizing a single illumination event for each generated volume, it eliminates the need for repeated illumination to capture individual image pixels or 2D images in order to acquire a sample volume, keeping light exposure

short and to a minimum. This combination makes Lightfield 4D the perfect method to capture fast processes, as well as image data from multiple living samples, over long periods of time.

The generated Z-stacks are saved in the standard .czi file format used by ZEN, allowing for all the same rendering and analysis options as for any other Z-stack created in ZEN. For reproducible, reliable, and trusted research, all 37 individual images are saved as raw data for your instant and future access.

More information:

Lightfield 4D

Keeping pace with the pulse of life

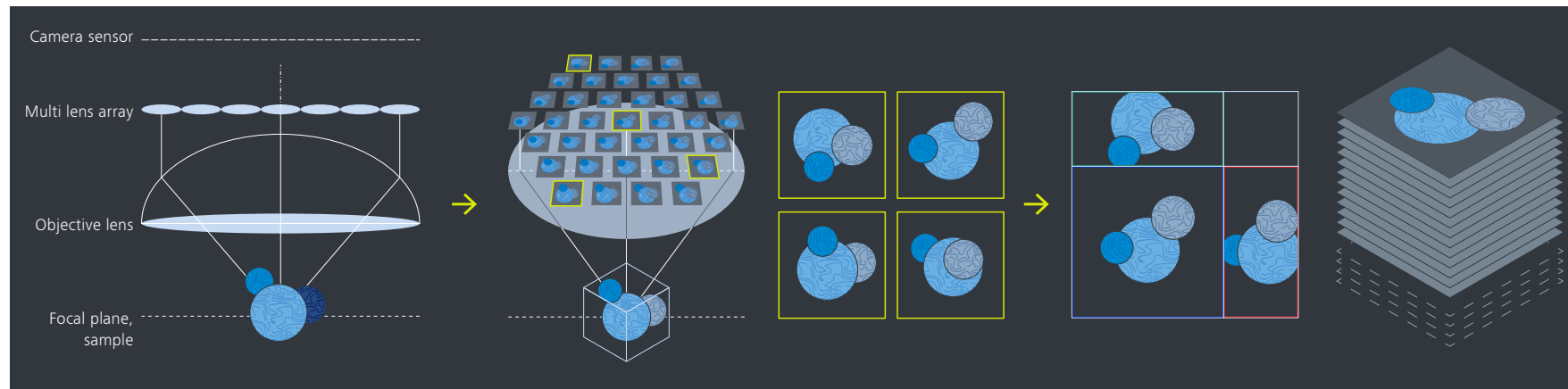

A micro lens array positioned in between objective and camera generates 37 individual images, collecting all of the 3D information at the same instant.

Each of 37 different views provides both spatial and angular information which contributes to the volumetric information of the sample. Lightfield 4D can generate 80 of such volumes per second.

Through deconvolution-based processing, Z-stacks are generated and saved in the .czi file format, allowing for all rendering and analysis options available in ZEN and arivis Pro.

Multiphoton imaging

Exploring at greater depth

- › In Brief
- › The Advantages
- › **Technology Insights**
- › The System
- › Technical Specifications
- › Service

Multiphoton microscopy – also referred to as two-photon or non-linear optical (NLO) microscopy – is perfect for recovering information from deep within tissue, such as brain, whole organisms, organoids or spheroids – in living samples or cleared tissues. The longer excitation wavelengths (690 – 1300 nm) are less absorbed and less scattered by tissues and no pinhole is needed to achieve optical sectioning.

All emission light originates from the excitation volume and can be efficiently directed to an NDD (non-descanned detector), which can be as close to the objective lens as the two-channel NDD GaAsP option within the objective nosepiece of the Axio Examiner microscope.

NDDs are optimal to capture all emission light, especially when using multiphoton imaging at the maximum depth. Even scattered light can be caught by the large diameter optics and directed towards the high-sensitivity GaAsP detectors. Airyscan provides an area for photon collection greater than the usual pinhole diameter and in addition provides high-frequency spatial information that is usually not available for multiphoton signals, increasing signal-to-noise ratio and spatial resolution. As long as the proportion of non-scattered light in the captured signal is high enough, choosing Airyscan will clearly improve multiphoton imaging. If deeper imaging is required, using NDDs and LSM Plus will seamlessly pick up for the best imaging results.

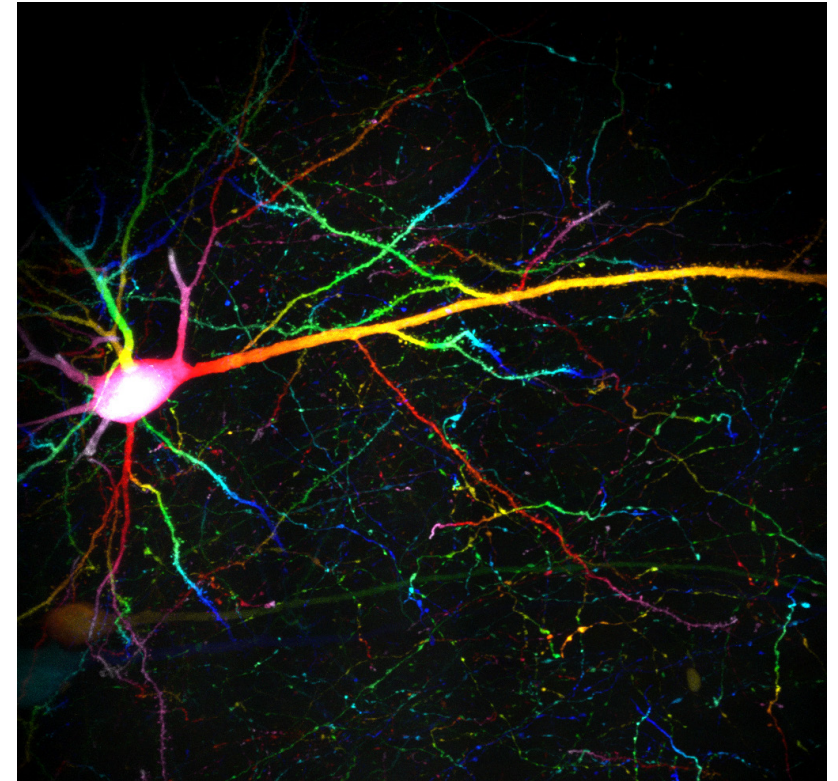

*Mouse brain slice with neuronal cytoplasmic GFP label. The 100 μm volume was acquired with two-photon laser excitation at 1,000 nm with the GaAsP BiG.2 non-descanned detector. The dataset was colour coded for depth and an orthogonal projection was created with ZEN blue.
Sample courtesy of Prof. J. Herms, LMU, Munich, Germany*

Multiphoton imaging

Exploring at greater depth

- › In Brief
- › The Advantages
- › **Technology Insights**
- › The System
- › Technical Specifications
- › Service

Several fluorophores can be excited simultaneously with one or two independent NLO wavelength lines, while spectral detection flexibility is provided with up to 7 NDD channels in reflection position or up to 36 channels of the LSM 990 for a full immediate Lambda Scan. Regardless of how the spectral signal is collected, it can be separated with the sophisticated Linear Unmixing algorithms using a processing pipeline during multi-dimensional experiments. To improve every image acquired, LSM Plus can be added in a single step to any workflow and enhance signal-to-noise ratio and spatial resolution, providing reliable and quantifiable results.

Even non-stained structures can be visualized with multiphoton excitation by second or third harmonic generation (SHG, THG). SHG effects occur on non-centrosymmetric molecules with predominantly periodic alignment, for example striated muscles and collagen. These signals are captured with NDDs in the transmitted light beam path and can be combined simultaneously with fluorescent signals caught in the reflection beam path.

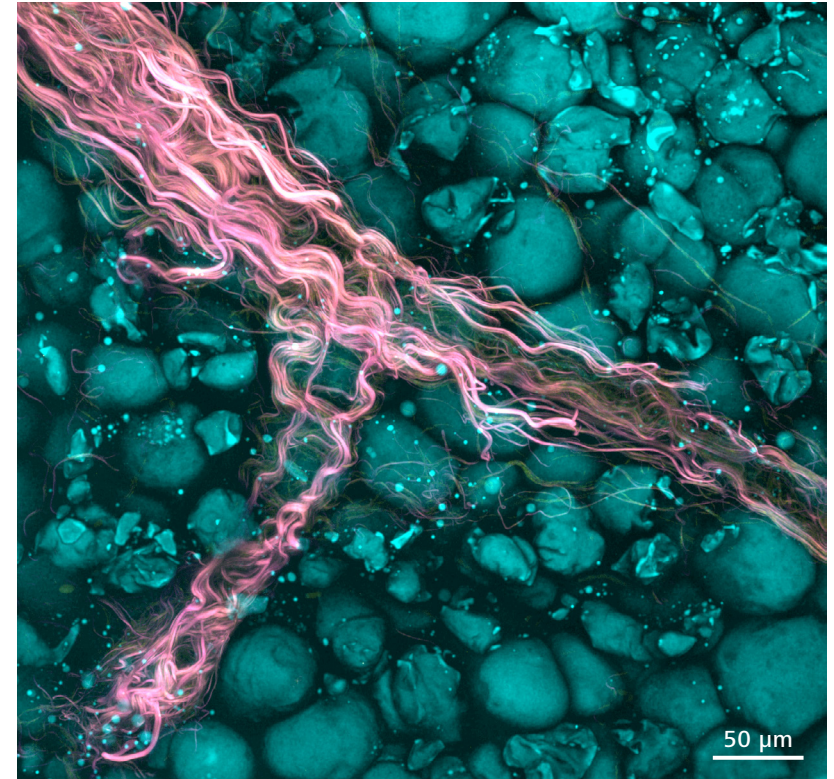

Section of mouse adipose tissue, label free, showing collagen from connective tissue by second harmonic generation (SHG) in magenta and adipocytes by third harmonic generation (THG) in cyan. LSM Plus was applied to SHG signal while THG was smothered by Gauss filter. Sample courtesy of Corinne Barreau, RESTORE, Toulouse, France

Clearing

Transparent information from the deepest layers

- › In Brief
- › The Advantages
- › **Technology Insights**
- › The System
- › Technical Specifications
- › Service

Clearing dramatically increases optical penetration depth into biological samples such as spheroids, organoids, tissue sections, mouse brains, whole organisms, or organs. The cleared tissue becomes almost transparent, and clearing objectives adjust to match the refractive index of the clearing media and the immersion medium, delivering crisp contrast. Imaging cleared samples with optimized clearing objectives enables up to six times deeper imaging than with a multi-photon microscope, and up to 60 times deeper imaging than with a conventional laser scanning microscope.

Get ready to be impressed by the quality of structural information you will retrieve from the deepest layers.

With LSM 990 based on the ZEISS Axio Examiner platform and special objectives optimized for different clearing media, you can look up to 5.6 mm deep into tissue:

- Clr Plan-Apochromat 10x/0.5 nd=1.38
- Clr Plan- Apochromat 20x/1.0 Corr nd=1.38
- Clr Plan-Neofluar 20x/1.0 Corr nd=1.45
- Clr Plan-Neofluar 20x/1.0 Corr nd=1.53

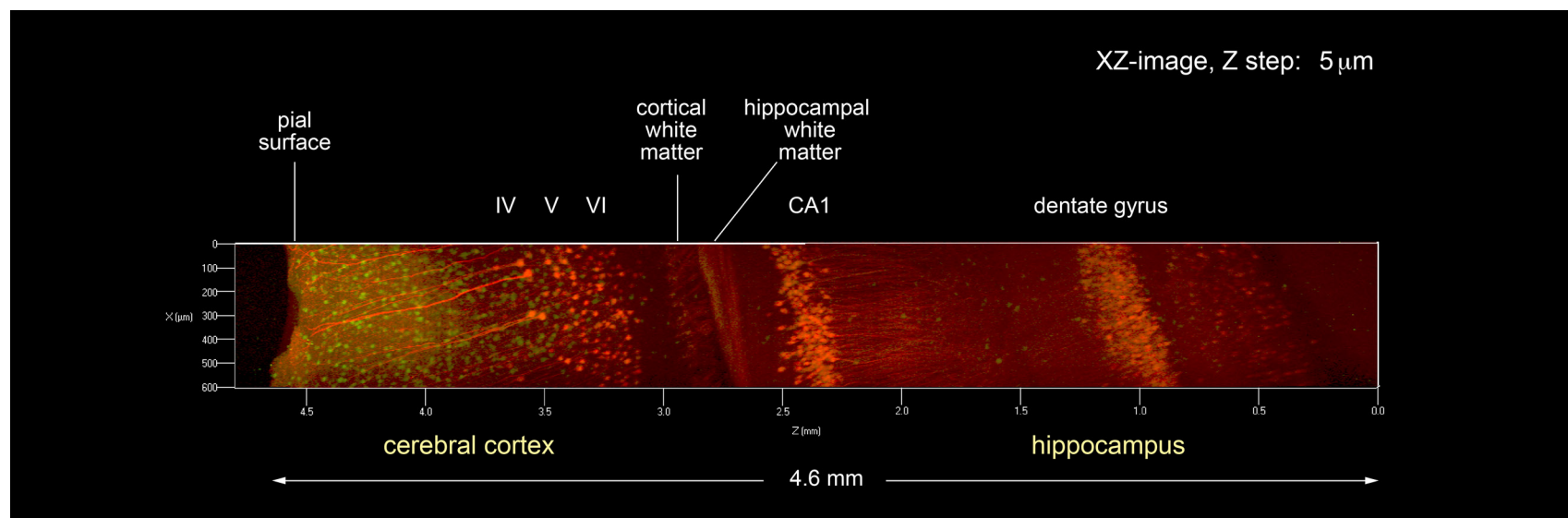
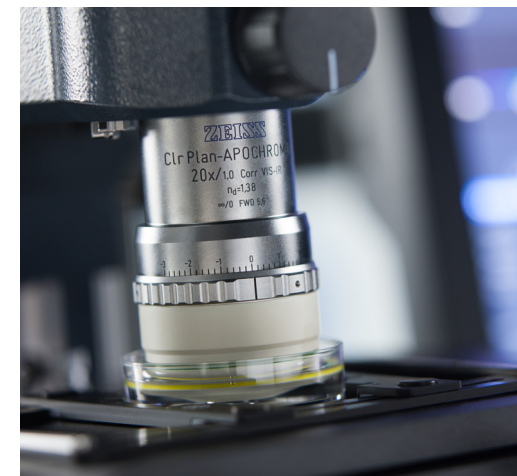

Maximum intensity projection, brain of 7-week old YFP-H mouse, fixed and cleared with Scale clearing technique (Hama et al, Nat Neurosci. 2011).
Courtesy of H. Hama, F. Ishidate, A. Miyawaki, RIKEN BSI, Wako, Japan

Data beyond imaging

A range of options to discover more

› In Brief

› The Advantages

› **Technology Insights**

› The System

› Technical Specifications

› Service

The combination of laser point illumination, linear scanning, and detectors that can capture the signal in photon counting mode make your LSM 990 more than an imaging device:

- **Spectral Raster Image Correlation Spectroscopy (Spectral RICS)** can generate a display map of molecular concentrations and diffusion coefficients of a complete image frame of a cell, or other structures. With Spectral RICS, fluorescent signals can be spectrally separated before analyzing protein interactions.
- **Fluorescence Correlation Spectroscopy (FCS)** allows a non-invasive insight into molecular concentrations and diffusion processes, leading to a deeper understanding of cell functions. To measure on a single molecule basis, you can use single- or multiphoton laser lines and use the full emission range up to 900 nm.
- **Fluorescent Cross Correlation Spectroscopy (FCCS)** allows you to observe molecular interactions between two or more differentially labelled molecules. By utilizing the numerous detectors of the LSM 990 system, up to 9 channels are available for FCCS experiments.
- **Fluorescence Lifetime Imaging Microscopy (FLIM)** uses differences in fluorescence decay to separate components. It is used for functional imaging and takes into account how fluorescence lifetime can be influenced by multiple factors, such as ion or oxygen concentration, pH, and temperature. FLIM is beneficial for FRET measurements, analyzing proximity of and interaction between molecules.
- **Fluorescence Resonance Energy Transfer (FRET)** uses sensitized emission or acceptor photobleaching approaches to investigate protein interaction and distance.
- **Fluorescence Recovery after Photobleaching (FRAP)** utilizes any of the laser lines to perform flexible photobleaching experiments. The same principle adheres to photomanipulation experiments in general, for example to investigate intracellular movement, or follow whole cell movement within organisms by photoconversion of fluorescent protein labels.

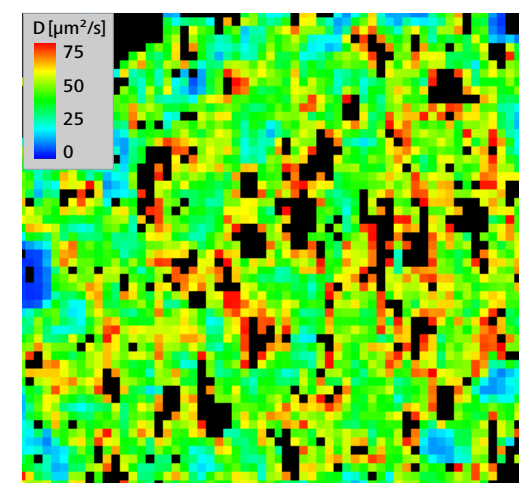
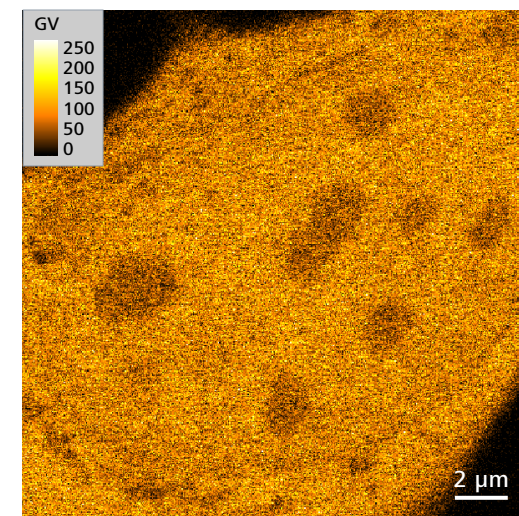

RICS measurement, using U2OS cells expressing monomeric eGFP. The diffusion of the target can be displayed as a map (bottom) based on the intensity image (top).

Sample courtesy of P. Hemmerich, Leibniz Institute on Aging – Fritz Lipmann Institute, Jena Germany

ZEISS Correlative Cryo Workflow

Image the near-to-native state

- › In Brief
- › The Advantages
- › **Technology Insights**
- › The System
- › Technical Specifications
- › Service

More information:

Correlative Cryo Workflow

Image the near-to-native state



TEM lamella preparation and volume imaging under cryogenic conditions

Spindle pole bodies are difficult to localize within yeast cells. They are small and rarely occurring structures. ZEISS Correlative Cryo Workflow lets you precisely identify and image such cellular structures in the near-to-native state. The LSM with the Airyscan detector makes the identification of these structures even easier so further details can be imaged. All images – from a large overview of the entire cell to high-resolution images of these tiny structures – are organized in a ZEN Connect project, providing all data needed to re-locate these cellular structures in the FIB-SEM.

Using ZEISS Crossbeam, TEM lamella of the identified regions can be prepared for cryo electron tomography. Volume imaging is possible as well. Furthermore, the workflow solution allows you to reconnect all data after image acquisition. Images from the Crossbeam or tomograms from the TEM can be combined with the LSM data and can be rendered in three-dimensional context.

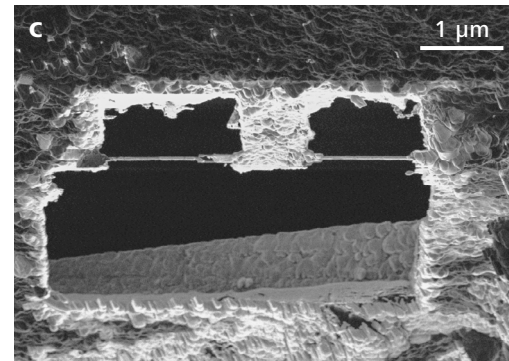
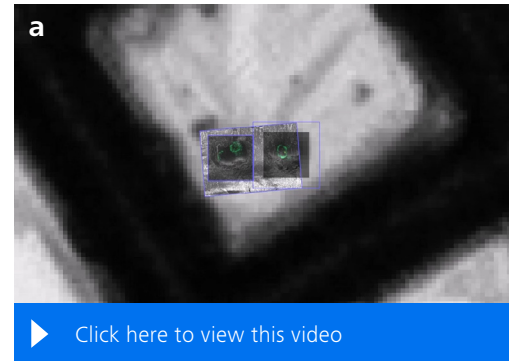

Yeast cells labeled with NUP (nuclear pore complex)-GFP and CNM67-tdTomato. Sample and tomogram courtesy of M. Pilhofer, ETH Zürich, Switzerland

- Overlay of an LM and EM dataset – from the grid overview to the region of interest identified for further TEM tomography.
- Early state of the milling process: Lamella is prepared around the marked region which was identified at the LSM.
- FIB image of the prepared lamella; lamella thickness: 230 nm
- 3D overlay of the reconstructed and segmented tomogram with LSM dataset (Spindle pole body is false-colored in cyan); nuclear membrane and microtubules were segmented using IMOD.
- Segmented and reconstructed tomogram

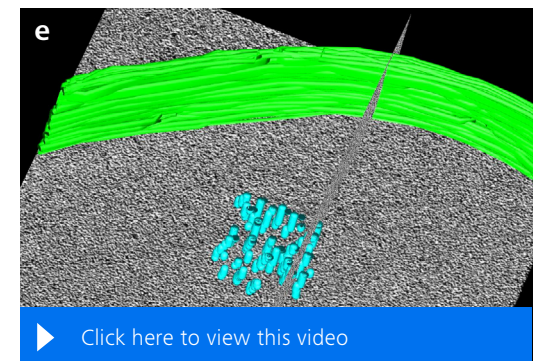
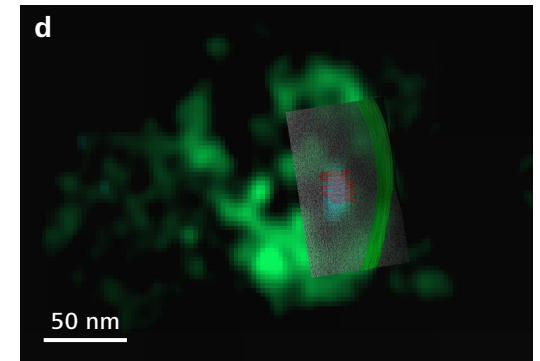
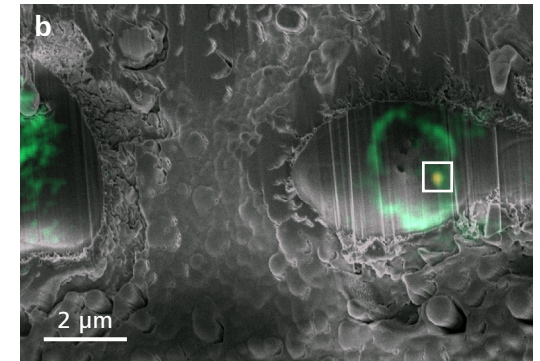

ZEN

Your complete microscopy software solution from sample to knowledge

- › In Brief
- › The Advantages
- › **Technology Insights**
- › The System
- › Technical Specifications
- › Service

ZEN is the universal user interface you will see on every imaging system from ZEISS. For simple and routine work, ZEN leads you straight to results. For complex research experiments, ZEN offers the flexibility to design multi-dimensional workflows the way you want. No matter what microscopy task you have, you will find intuitive tools and modules to assist you:

- Acquire images using smart automation
- Process images with scientifically proven algorithms
- Visualize big data by a GPU powered 3D engine
- Analyze images via Machine Learning-based tools
- Correlate image data between light and electron microscopes
- Compress data without loss to speed up file transfer and save storage space costs

More information:

ZEN

Your complete solution from sample to knowledge

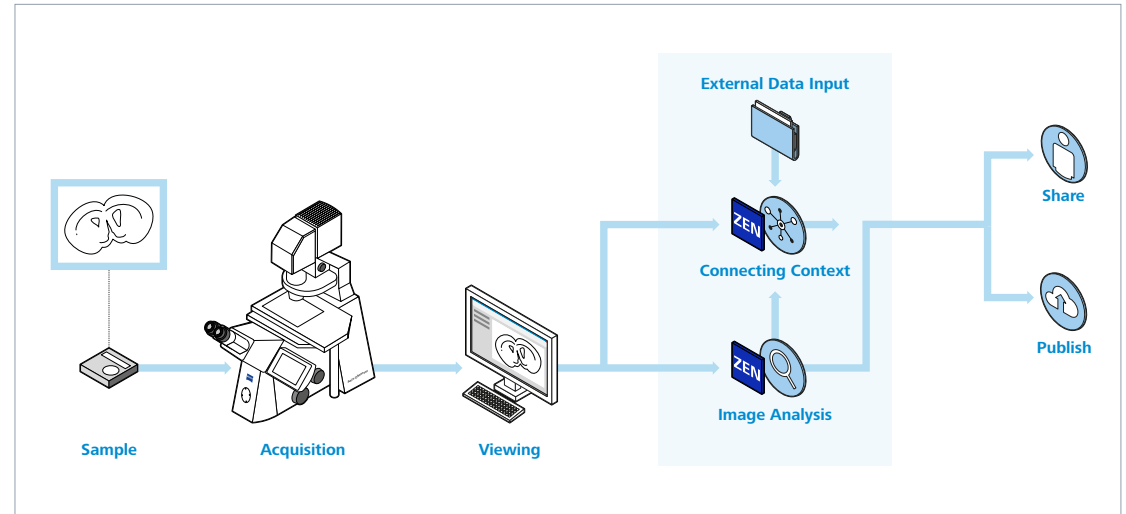

ZEN microscopy software integrates all steps from your sample to reproducible data for publication.

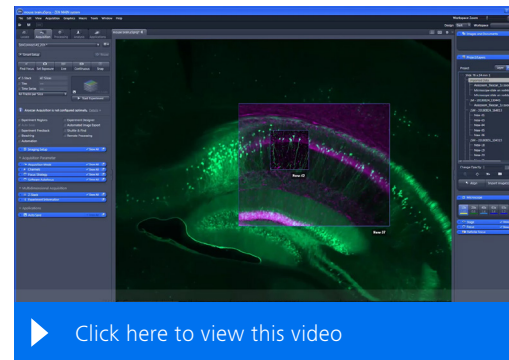

Connect all your imagery: With the Connect Toolkit you bring images and data from any system or modality together. You always keep the context and the overview about all data from your sample.

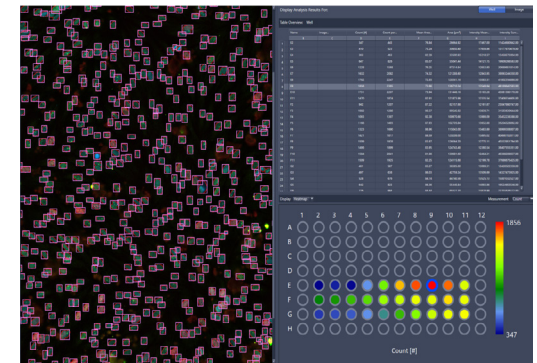

Bio Apps Toolkit: From beautiful images to valuable data – analyze your images efficiently.

arivis Pro

Your end-to-end scientific image analysis platform

- › In Brief
- › The Advantages
- › **Technology Insights**
- › The System
- › Technical Specifications
- › Service

More information:

arivis Pro

Your solution for advanced image analysis and visualization



ZEISS arivis Pro empowers you to automate image analysis and visualization pipelines. Leverage traditional methods or AI models effortlessly to create pipelines for any image size, dimension, or modality without the need to code yourself. The heart of arivis Pro is the easy handling of very large image files. It supports and manages over 30 commercial file formats so that you can always take advantage of its benefits. Pre-configured pipelines and standard assays are available for both simple and demanding analysis tasks. Alternatively, you can build customized pipelines for your specific goals. It takes just one click to repeat your same analysis on further datasets for quantitative and reproducible results. Boost productivity for these and more analyses:

- Advanced 3D analysis
- High content analysis
- Tracking and lineage
- Neurobiology: neuron tracing

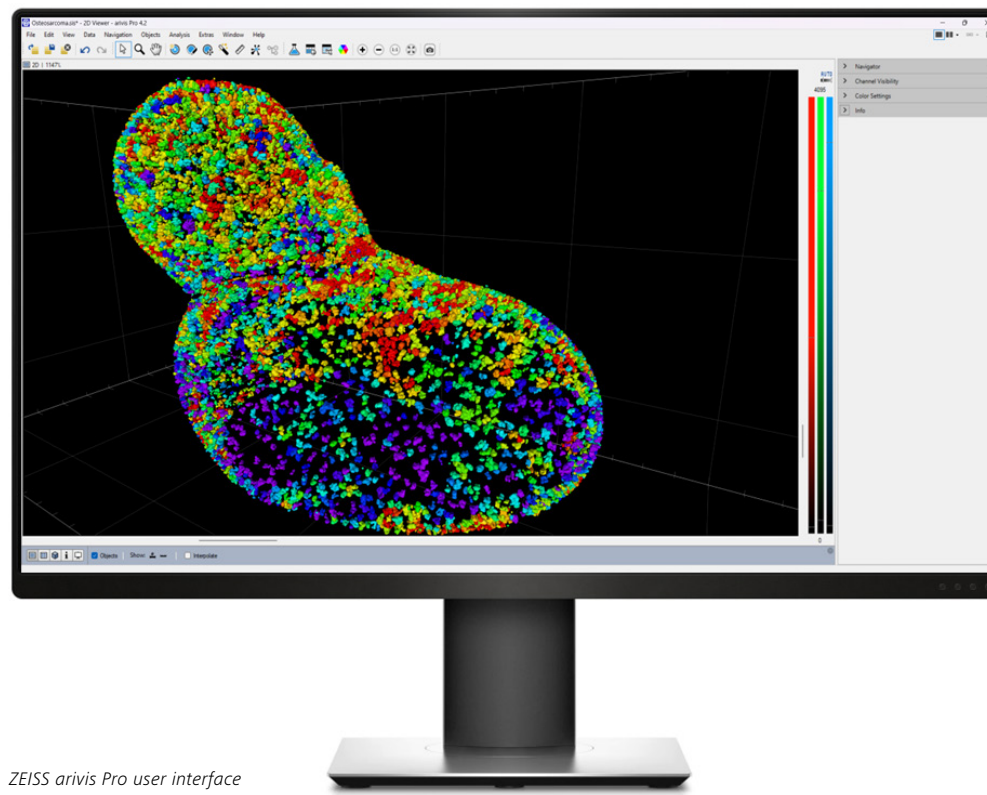

ZEISS arivis Pro user interface

Your flexible choice of components

- › In Brief
- › The Advantages
- › Technology Insights
- › **The System**
- › Technical Specifications
- › Service

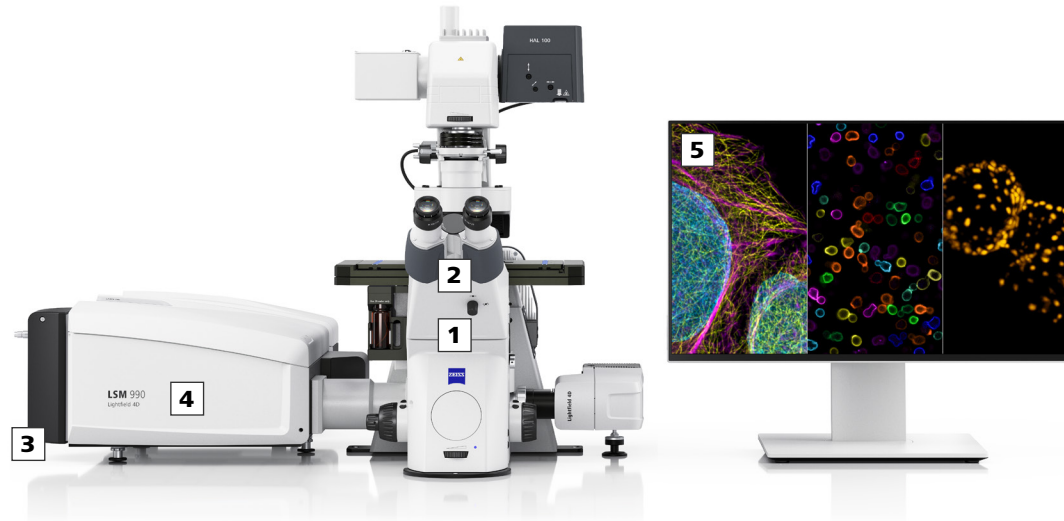

1 Microscope

- Inverted stand: Axio Observer
- Upright stand: Axio Examiner, Axio Imager
- Port for coupling of Elyra 7 (Axio Observer)*
- Camera port
- AI Sample Finder for Axio Observer
- Manual or motorized stages
- Incubation solutions
- Fast Z piezo inserts
- Definite Focus

2 Objectives

- C-Apochromat, C Plan-Apochromat
- Plan-Apochromat
- W Plan-Apochromat, Clr Plan-Apochromat
- Clr Plan-Neofluar
- LD LCI Plan-Apochromat

3 Illumination

- V laser: 405 nm
- VIS + NIR laser: 445 nm, 488 nm, 514 nm, 543 nm, 561 nm, 594 nm, 639 nm, 730 nm
- Laser for multiphoton imaging: Ti:Sa (single-line laser), InSight X3 / X3+ and Discovery NX (dual-line laser)

4 Detection

- 3, 6, or 34 descanned spectral channels (GaAsP and MA-PMT)
- NIR Detector (2 channels): infrared optimized GaAsP and GaAs detector also with counting function for FCS and FLIM**
- BiG.2 (2 GaAsP channels) also with counting function for FCS and FLIM**
- Up to 6 non-descanned GaAsP detectors
- Up to 12 non-descanned GaAsP and multialkali PMT detectors
- Airyscan 2 detector
- Lightfield 4D for Axio Observer
- Transmitted light detector (T-PMT)

5 Software

- ZEN microscopy software, highlighted modules and functions: LSM Plus, Airyscan Joint Deconvolution, Dynamics Profiler, Tiles & Positions, Experiment Designer, FRAP, FRET, FCS, Spectral RICS, Connect Toolkit, Direct Processing, 3D Toolkit

* available on request
 ** alternatives

Expand your possibilities

- › In Brief
- › The Advantages
- › Technology Insights
- › **The System**
- › Technical Specifications
- › Service

As your needs grow, your LSM 990 grows with you, forming the basis for a number of enhancements. Like every system from ZEISS, open interfaces and a modular architecture guarantee the seamless interaction of all components now and in the future. These include:



Combine your ZEISS LSM 990 with integrated incubation modules to create the perfect environment for long-term live cell imaging with stable temperature conditions.



The upright fixed stage microscope ZEISS Axio Examiner.Z1 gives you ample specimen space and room for imaging of whole animals. This stable stand is ideally suited for your demanding multiphoton experiments with incubation for living specimens.



AI Sample Finder automatically detects your sample carrier, adjusts the focus, and finds your sample regions on the coverslip. Even with low-contrast samples, you will access relevant regions with just a click and start your experiment right away.



Add the BiG.2 module with its two GaAsP detectors for FCS, photon counting experiments and FLIM to your ZEISS LSM 990.*

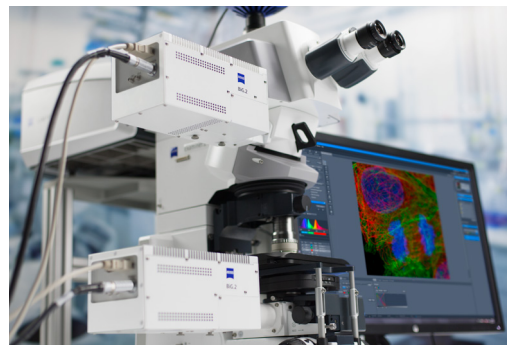

Your BiG.2 works perfectly as a non-descanned detector, also providing a highly sensitive direct coupled detector for FLIM.*

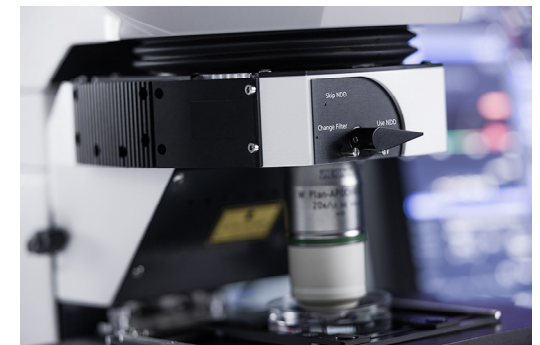

The module GaAsP NDD 2 channels with flexible filter settings completes the ensemble of non-descanned detectors for ZEISS Axio Examiner.Z1.

* available upon request

Expand your possibilities

- › In Brief
- › The Advantages
- › Technology Insights
- › **The System**
- › Technical Specifications
- › Service



Enhance your microscope with ZEISS Viluma 7. This flexible and efficient LED light source allows to screen and image your delicate fluorescent samples very gently. You profit from stable illumination and extremely long lamp life.

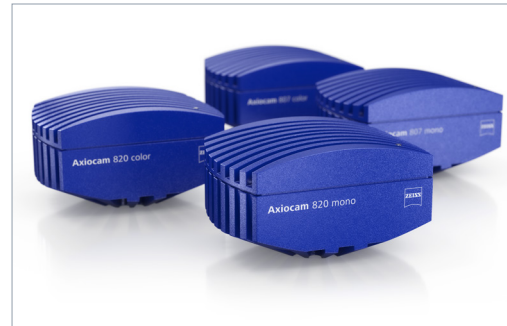

You can add a choice of sensitive ZEISS Axiocams to your ZEISS LSM 990. It's very easy to acquire overview images for your multiposition experiments or to perform light efficient widefield imaging.



With autocorr objectives and ZEN microscopy software it's easy to adjust your microscope optics to your sample. You get crisp contrast and better signal to noise – even in your most challenging samples.



The Autoimmersion Module automates the application of immersion media for water immersion objectives. The immersion media is applied while maintaining objective focus and position, leaving your experiments undisturbed.



Definite Focus 3 compensates Z-drift and stabilizes the focal position of your sample. You can now perform long-term multiposition and tiling experiments that can last for multiple days.



Combine your LSM 990 with Elyra 7 and Lattice SIM² to always choose the best super-resolution technique for your experiment.*

* available upon request

Expand your possibilities

- › In Brief
- › The Advantages
- › Technology Insights
- › **The System**
- › Technical Specifications
- › Service

ZEISS Predictive Service

Maximizes System Uptime

Once connected to your network and activated, this advanced technology will automatically track the health status of your instrument and collect system log files in the background to improve remote diagnosis.

Relevant technical data such as operating hours, cycle counts or voltages are periodically monitored via a secure connection to our data center. The ZEISS Predictive Service application evaluates the performance of your microscope as system data can be received and analyzed.

Our support engineers will diagnose any issues by analyzing data on the Enterprise Server – remotely and without interruption to your operation.

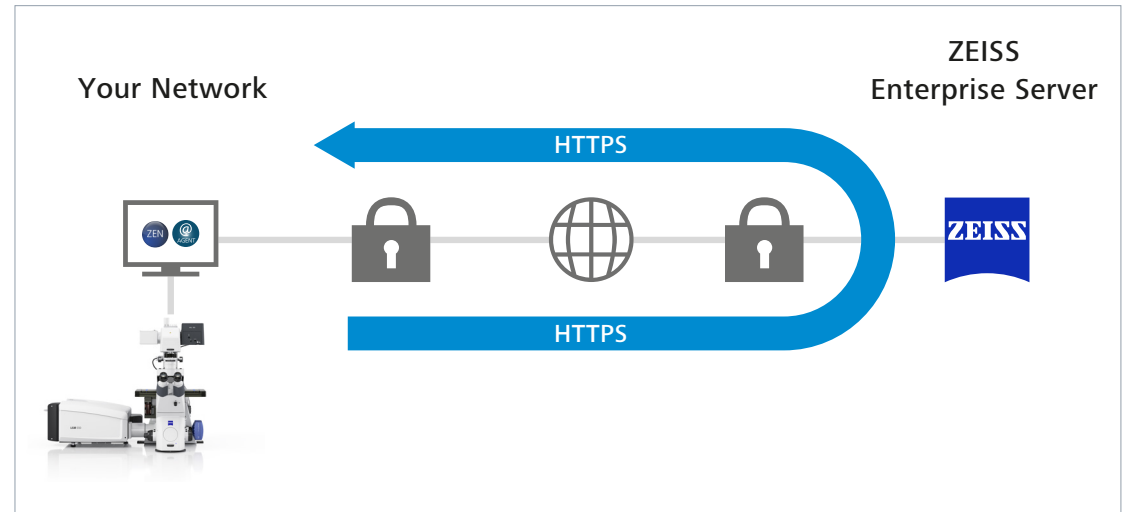

■ **Maintain highest system availability**

Increase your uptime through close monitoring of the system's condition as remote support can often provide immediate solutions.

■ **Data security**

Ensure highest data security standards using well established technologies like PTC Thingworx and Microsoft Azure Cloud. No personal or image data is uploaded, only machine data.

■ **Fast and competent support**

Use secure remote desktop sharing to easily get an expert connected.

■ **Optimum instrument performance**

As the status of your system is monitored, necessary actions can be planned before they become urgent.

Technical specifications

- › In Brief
- › The Advantages
- › Technology Insights
- › The System
- › **Technical Specifications**
- › Service

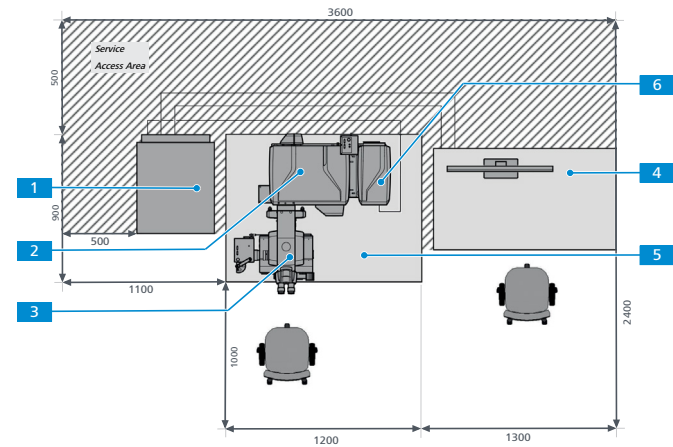
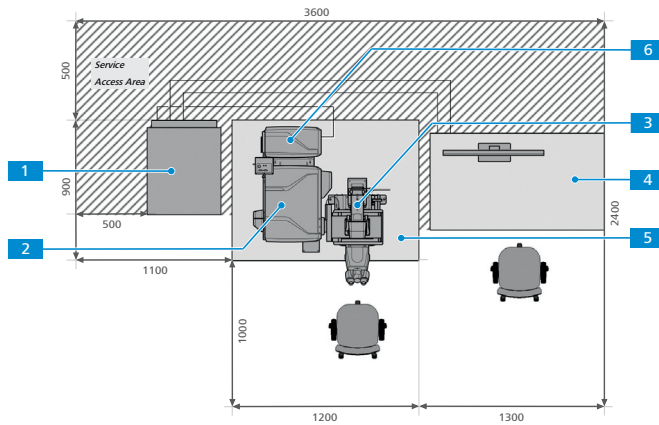
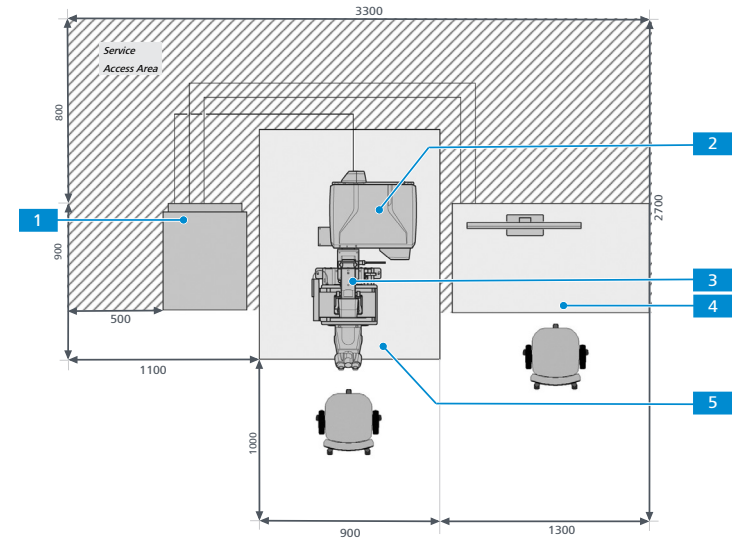
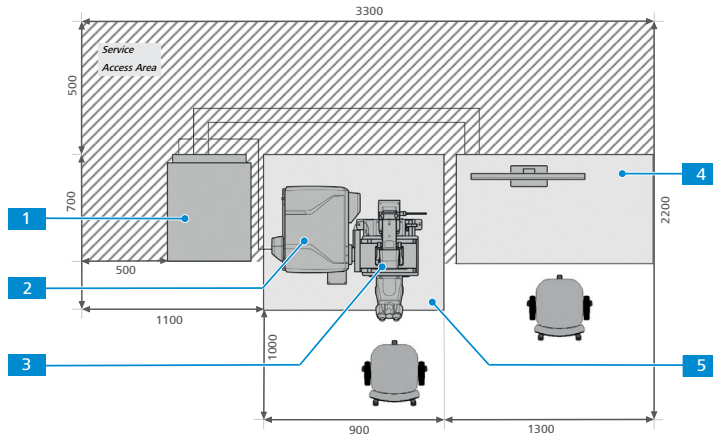

- 1 Laser and Power Supply Module 2 LSM 990 Scanhead 3 Microscope Stand (Axio Observer, Axio Imager or Axio Examiner) 4 Computer Table 5 System Table 6 Airyscan 2

Technical specifications

- › In Brief
- › The Advantages
- › Technology Insights
- › The System
- › **Technical Specifications**
- › Service

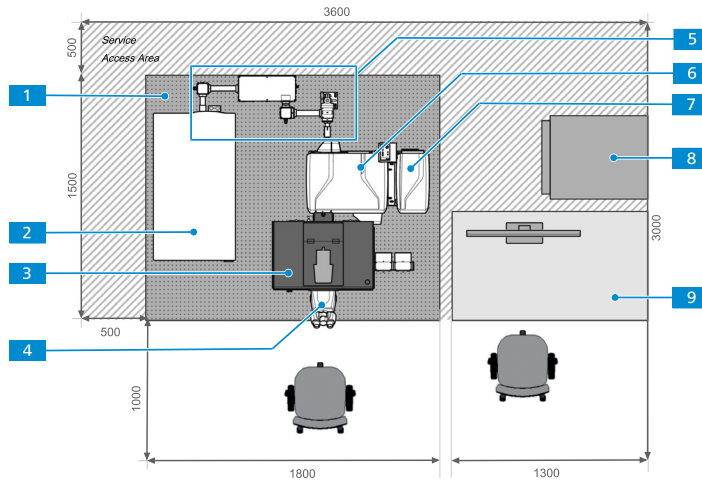

- 1 System Table
- 2 Multiphoton Laser
- 3 Incubation
- 4 Microscope Stand (Axio Observer, Axio Imager or Axio Examiner)
- 5 Laser coupling with AOM for multiphoton laser
- 6 LSM 990 scanning module
- 7 Airyscan 2
- 8 Laser and Power Supply Module
- 9 Computer Table

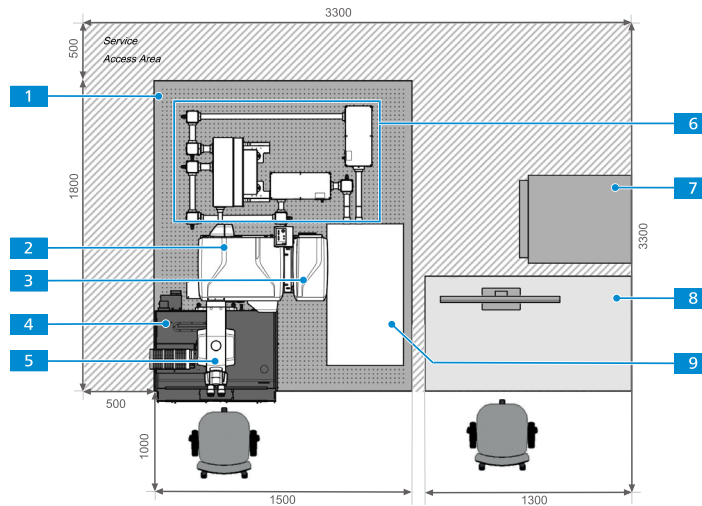

- 1 System Table
- 2 LSM 990 scanning module
- 3 Airyscan 2
- 4 Incubation
- 7 Laser and Power supply module
- 8 Computer Table
- 9 Multiphoton Laser

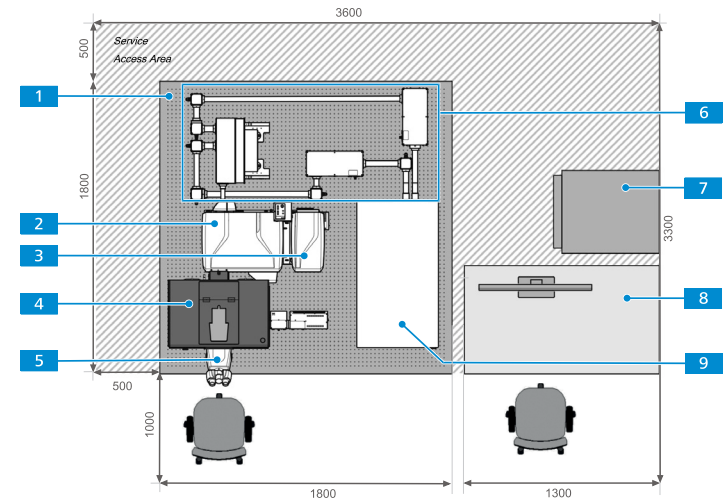

- 5 Microscope Stand
- 6 Laser coupling with AOM for multiphoton

Technical specifications

- › In Brief
- › The Advantages
- › Technology Insights
- › The System
- › **Technical Specifications**
- › Service

Physical Dimensions	Length (cm)	Width (cm)	Height (cm)	Weight (kg)
Small Passively Damped System Table	90	75	83	130
Small Actively Damped System Table	90	75	81	130
Large Actively Damped System Table	120	90	86	180
Active Anti-Vibration Table (NLO)	180	150	91	475
Active Anti-Vibration Table (NLO)	180	180	91	515
Scanning Module LSM 990	55	45	22	27
Microscope	47–80	29–39	70–72	37–47
Laser and Power Supply module	60	50	56	70
Airyscan 2	40	20	24	12
Fiber Optic Cable, UV	400			
Fiber Optic Cable, VIS	400			
Cables	250			

Microscopes

Stands	Upright: Axio Imager.Z2, Axio Examiner.Z1 Inverted: Axio Observer 7 with side port or rear port, AI Sample Finder (optional)
Z Drive	Smallest increment Axio Imager.Z2: 10 nm; Axio Observer 7: 10 nm; Axio Examiner.Z1: 25 nm; fast piezo objective or stage focus available; Definite Focus 3 for Axio Observer 7
XY Stage (optional)	Motorized XY scanning stage, for Mark & Find function (XYZ) as well as Tile Scan (Mosaic Scan); smallest increment of 0.25 μm (Axio Observer 7), 0.2 μm (Axio Imager.Z2) or 0.25 μm (Axio Examiner.Z1)

Technical specifications

- › In Brief
- › The Advantages
- › Technology Insights
- › The System
- › **Technical Specifications**
- › Service

Scanning Module	
Scanner	Two independent, galvanometric scanning mirrors with ultrashort line and frame flyback
Scanning Resolution	32 × 1 to 8,192 × 8,192 pixels (Airyscan 2: 5,120 × 5,120 pixels), also for multiple channels, continuously adjustable
Scanning Speed	At 512 × 512 pixels: confocal – up to 13 fps; 34-Channel Lambda Scan up to 5 fps; Airyscan SR – up to 4.7 fps; Multiplex SR-4Y – 25 fps; Multiplex SR-8Y – 47.5 fps; Multiplex CO-8Y – 34.4 fps; SR/CO-8Y at 576 × 452 – 60.8 fps; 19 × 2 speed levels for confocal; 512 × 16 pixels up to 425 fps; up to 6830 lines/sec. 13 × 2 speed levels in Multiplex mode; up to 25 fps for 904 × 904 pixels; up to 17.8 fps at 1,024 × 1,024 pixels
Scanning Zoom	0.6x to 40x; digitally adjustable in increments of 0.1 (Axio Examiner: 0.7x to 40x)
Scanning Rotation	Can be rotated freely (360 degrees), adjustable in increments of 0.1 degree, freely adjustable XY offset
Scanning Field	20 mm field diagonal (max. 17 mm for Axio Examiner) in the intermediate image plane, with full pupil illumination
Pinholes	Master pinhole with preset size and position; can be adjusted as desired for multitracking and short wavelengths (such as 405 nm)
Beam Path	Exchangeable Twin Gate beamsplitter with up to 100 combinations of excitation wavelengths and outstanding laser line suppression; manual interface port for two external detection modules (such as NIR, BiG.2, Airyscan 2, third party detectors), internal detection with spectral signal separation and signal recycling loop for compensation of polarization effects
Detection Options	
Detectors	1, 4 or 32 GaAsP PMT combined with 2 multialkali PMT internal spectral detection channels (QE 45 % typical for GaAsP); LSM Plus: resolution down to 160* nm lateral, 500** nm axial with pinhole at 0.8 AU; resolution down to 120* nm lateral, 500** nm axial with pinhole at 0.3 AU Additional Detection: 2ch NIR (GaAs and NIR GaAsP) detection or 2ch BiG.2 (UV-Vis GaAsP) detection Airyscan 2 detector (32 channels GaAsP), delivers resolution of 120* nm lateral, 350** nm axial; with jDCV: down to 90* nm lateral (80*** nm), 200*** nm axial; Multiplex resolution: SR-4Y: 140* nm lateral, 450** nm axial; with jDCV down to 120* nm lateral (80*** nm), 250*** nm axial SR-8Y: 120/160* nm lateral, 450** nm axial; with jDCV down to 120* nm lateral (80*** nm), 250*** nm axial Up to 12 non-descanned detection channels (PMT and/or GaAsP) depending on microscope stand Transmitted light detector (PMT)
Spectral Detection	3, 6, or 34 + 2 NIR simultaneous, confocal reflected-light channels, GaAs, GaAsP (UV-Vis and NIR) and multialkali PMT based; freely adjustable spectral detection area (resolution down to 3 nm)
Data Depth	8 bit or 16 bit available; up to 36 channels simultaneously detectable
Real-time Electronics	Microscope, laser, scanning module and additional accessory control; data acquisition and synchronization management by highest bandwidth real-time electronics; oversampling read-out logic; ability to evaluate data online during image acquisition

* Measured with respective nanoruler samples

** Measured with 100 nm Beads

*** Measured with 23 nm Beads

Technical specifications

- › In Brief
- › The Advantages
- › Technology Insights
- › The System
- › **Technical Specifications**
- › Service

Lasers

Laser RGB (445, 488, 514, 543, 561, 594, 639 nm)	Single-mode polarization preserving fiber
	Laser beam attenuation for all lasers by VIS-AOTF
	Diode Laser 445 nm (30 mW nominal power; 7.5 mW ex fiber)
	Diode Laser 488 nm (30 mW nominal power; 10 mW ex fiber)
	Diode Laser 514 nm (30 mW nominal power; 10 mW ex fiber)
	DPSS Laser 543 nm (25 mW nominal power; 10 mW ex fiber)
	DPSS Laser 561 nm (25 mW nominal power; 10 mW ex fiber)
Laser V and NIR (405 and 730 nm), directly modulated; modulation depth 1:500	DPSS Laser 594 nm (8 mW nominal power; 2.5 mW ex fiber)
	Diode Laser 639 nm (25 mW nominal power; 7.5 mW ex fiber)
	Single-mode polarization preserving fiber
	Diode Laser 405 nm (30 mW nominal power; 14 mW ex fiber)
	Diode Laser 730 nm (20 mW nominal power; 9.5 mW ex fiber)

FLIM Detectors

BiG.2 (confocal and FLIM);
 or 1 or 2 PMA Hybrid detectors (QE 45 % typical @550 nm); 80 MCps sustained count rate, without afterpulsing, spectral detection range from 300 nm to 720 nm, timing resolution (IRF) typically 120 ps (FWHM), very low dark counts due to active temperature stabilization
 Confocal or non-descanned FLIM detection

TCSPC Electronic

MultiHarp 150 4P for time-correlated single photon counting (TCSPC) with 5 ps temporal resolution (time bin width), 65536 time channels, 80 MCps sustained countrate sum over all input channels, 1500 MCps peak count rate (for burst duration up to 1.3 μ s), 0.65 ns dead time, 4 fully independent input channels and common sync channel for synchronization with excitation source (up to 1.2 GHz sync rate)

Pulsed Excitation for FLIM

Laser combining unit with up to 4 excitation lines (fully motorized), including collimator and temperature stabilization for stable measurement conditions
 Single-mode polarization preserving fiber
 Laser intensity control without affecting the pulse width and beam shape, for all lasers and each individual line
 Variable repetition rate and excitation schemes, e.g., PIE (pulsed interleaved excitation)
 Pulsed Diode Laser 440 nm (4 mW @40 MHz before fiber, 1–40 MHz repetition rate)
 Pulsed Diode Laser 485 nm (5 mW @40 MHz before fiber, 1–40 MHz repetition rate)
 Pulsed Diode Laser 510 nm (4 mW @40 MHz before fiber, 1–80 MHz repetition rate)
 Pulsed Diode Laser 560 nm (3 mW @80 MHz before fiber, 1–80 MHz repetition rate)
 Pulsed Diode Laser 640 nm (20 mW @80 MHz before fiber, 1–80 MHz repetition rate)
 Laser pulse width down to 50 ps

Nominal power = power level of laser itself, leaving out necessary tolerances and losses due to laser steering and stability requirements

Technical specifications

- › In Brief
- › The Advantages
- › Technology Insights
- › The System
- › **Technical Specifications**
- › Service

FLIM acquisition

Temporal resolution of the system (Instrumental Response Function, IRF) ~280 ps, system downtime 0.65 ns
 rapidFLIMHiRes fast data acquisition, counting of several photons per excitation pulse for up to 15 FLIM frames per second
 Detectable Fluorescence Lifetime range: 50 ps (1/6 of IRF) to 100 ns for imaging, 50 ps to 1 µs for point measurements

FLIM analysis

Fast FLIM, Pattern Matching and Fast Pattern Matching, Bin export for phasor analysis, Time-gated FLIM online and post-acquisition
 FLIM fitting per pixel, ROI or image (multi-Exponential Decay (1 to 5 Exponentials), Least-Squares Fitting, MLE Fitting, IRF Deconvolution, Tailfit, Bootstrap error analysis); Fluorescence lifetime and TCSPC histogram
 Quantitative FLIM-FRET analysis (PIE, correction for direct excitation and bleed through), FRET efficiency histogram, FRET Radius, Binding histogram, Batch analysis
 OME-TIFF, ASCII, TIFF, BIN, and BMP export

Lightfield 4D

Magnification	40x	25x	20x	10x	
RI Immersion	1.333	1.333	1	1	
Field of View	20.4 mm				
Object Field Size	361 × 361 µm ²	585 × 585 µm ²	720 × 720 µm ²	1444 × 1444 µm ²	Variance of up to 2 % from system to system
Z-Stack Range	109 µm	278 µm	430 µm	1712 µm	calculated
Aquisition Speed	up to 80 Volumes per Second				
Excitation Wavelength Range	405 – 740 nm				
X/Y Resolution *	2.2 µm	3.5 µm	4.4 µm	8.8 µm	measured, deconvolved
Z Resolution *	2.8 µm	8.4 µm	13.6 µm	57 µm	measured, deconvolved with optimal number of iterations
Voxel Size XYZ	0.7 × 0.7 × 0.9 µm ³	1.12 × 1.12 × 2.7 µm ³	1.4 × 1.4 × 4.4 µm ³	2.8 × 2.8 × 18 µm ³	
Stack Size XYZ *	512 × 512 × 121 Pixel ³	512 × 512 × 103 Pixel ³	512 × 512 × 99 Pixel ³	512 × 512 × 95 Pixel ³	

Recommended Objectives for Lightfield 4D

C-Apochromat 40x/1.2 W Corr M27
 Plan-Apochromat 40x/1.3 Oil DIC M27
 LD LCI Plan-Apochromat 40x/1.2 DIC M27
 LD C-Apochromat 40x/1.1 W Corr
 LD LCI Plan-Apochromat 25x/0.8 Imm Corr DIC M27
 Plan-Apochromat 20x/0.8 M27
 EC Plan-Neofluar 20x/0.50 M27
 Plan-Apochromat 10x/0.45 M27
 Plan-Apochromat 10x/0.3 M27
 EC Plan-Neofluar 10x/0.3 M27

* Measured with beads in agarose (RI =1.378) with air or water immersion respectively and excitation/detection wavelength (label) 488 nm/525 nm (eGFP)

Technical specifications

- › In Brief
- › The Advantages
- › Technology Insights
- › The System
- › **Technical Specifications**
- › Service

ZEN Microscopy Software	
System Configurations	Workspace to conveniently configure all of the motorized functions of the scanning module, laser and microscope; Save and restore application configurations as experiment settings or use acquired images (Reuse)
Maintenance and calibration Tools	Software tools and wizards to automatically test and calibrate the system
Recording Modes, Smart Setup	Spot, Line / Spline, Frame, Tiles, Z Stack, Lambda Stack, Time Series and all combinations (XYZ, lambda, t), online calculation and visualization of, average and summation (by line / image, adjustable), Step Scan (for higher image frame rates); Quick set up of imaging conditions using Smart Setup by simply selecting the labelling dye; Direct Processing: Processing of large data during acquisition by streaming, including e.g., Airyscan, LSM Plus, Spectral Unmixing; Analysis and storage on second PC
Crop Function	Easily select the scanning area by defining simultaneously zoom, offset and rotation
Real ROI Scan	Scan multiple ROIs (regions of interest) as desired and pixel-by-pixel laser blanking
Line and Spline curve Scan	Scan along a freely defined line
ROI Bleaching	Localized bleaching in multiple bleach ROIs for applications such as FRAP (fluorescence recovery after photobleaching) or uncaging; Use a speed or z-position different from imaging settings, use of different laser lines for different ROIs
Multitracking	Rapidly change excitation lines when recording multiple fluorescences for the purpose of minimizing signal crosstalk and increasing dynamic range
Airyscan Module	Permits processing and post-processing of acquired SR and MPLX data. Includes Joint Iterative methods, providing increased lateral resolution for Airyscan SR / MPLX data (requires Multiplex Mode) down to 90/120 nm Export of Airyscan RAW data.
Airyscan Multiplex Mode	Multiplex mode scan with 4x or 8x parallelisation in Y-direction, detection by Airyscan 2
Lambda Scan	Parallel or sequential acquisition of multidimensional images with spectral information for every pixel
Online Fingerprinting	Use of predefined spectra for on the fly unmixing of up to 29 dyes and directly visualise the result
Linear Unmixing	Acquisition of crosstalk-free, multiple fluorescence images using simultaneous excitation; Online or offline and automatic or interactive unmixing; Advanced unmixing logic with indication of reliability
Visualization	2D (XY); Split (XY-ch); Gallery (XY-ch, XY-Z), Orthogonal (XY, XZ, YZ) with adjustable cut lines, maximum intensity projection and 3D distance measurement; 2.5D viewing with various rendering options and animations; Histogram settings using channel specific brightness, gamma and contrast; color table selection and modification (LUT), various annotations
Image Analysis and Operations	Colocalization and histogram analysis with individual parameters, number & brightness analysis, profile measurement along user-defined lines, measurement of lengths, angles, areas, intensities and much more; operations: addition, subtraction, multiplication, division, ratio, shift, filters (low-pass, median, high-pass, etc., also user-definable)
Image Management	Features for managing images and the corresponding imaging parameters
Advanced Acquisition Toolkit	Z-stack and enhanced depth of focus functionality Tiles & Positions: Scanning of predefined sample areas (tiles) and/or position lists Software Autofocus: Determination of the optimal focus position in the sample
3D Toolkit	Combined 2D and 3D visualization in one screen Rapid 3D and 4D reconstructions and animations 3D segmentation to quantify 3D microscopy data based on thresholding and machine learning models

Technical specifications

- › In Brief
- › The Advantages
- › Technology Insights
- › The System
- › **Technical Specifications**
- › Service

Optional Software	
Deconvolution Toolkit	3D, GPU based image restoration based on calculated point-spread functions (modes: nearest neighbor, maximum likelihood, constrained iterative)
HDR	Imaging mode: High Dynamic Range, improvement of the dynamic signal range by combination of multiple images with ramped signal
Molecular Quantification Toolkit	Physiology (Dynamics): Comprehensive evaluation software for online and offline ratio imaging with various pre-defined formulas Acquisition of FRET (Förster resonance energy transfer) image data with subsequent evaluation Acceptor Photobleaching and Sensitized Emission methods supported Acquisition of FRAP (fluorescence recovery after photobleaching) experiments with subsequent evaluation of intensity kinetics
Spectral RICS	Single molecule imaging and analysis using multialkali or GaAsP PMT detectors with spectral unmixing step for clear signal separation (in collaboration with J. Hendrix)
Smart Acquisition Toolkit	Experiment Designer: Definition of customized imaging configurations and procedures Guided Acquisition: Automated and targeted acquisition of objects of interest
Developer Toolkit	Python scripting interface for automation & customization; experimental feedback for smart experiments and open interface to third party software (e.g. ImageJ)
Connect Toolkit	Exchange and alignment of image data from multiple image acquisition systems in 2D and 3D enabling correlative workflows
AI Toolkit	Image analysis and structure detection via computational self learning technology
FCS / FCCS	Fluorescence Correlation and Cross Correlation Spectroscopy for analysis of single molecule dynamics, concentration and number
AI Sample Finder, Sample Navigator (requires additional HW)	Easy to perform sample overview scan with autofocus function using AxioCam or transmitted fluorescence with T-PMT (Finder requires Axio Observer)
Bio Apps Toolkit	Easy-to-use and modular image analysis for common assays
LSM Plus	Increased resolution for confocal/spectral datasets down to 160 nm lateral (120 nm with closed pinhole = 0.3 AU), preview and Auto strength
Dynamics Profiler	Easy-to-use Airyscan-based data collection that captures the underlying dynamics of living samples to provide molecular concentration, asymmetric diffusion, and flow information (Axio Observer)

Technical specifications

-
- › In Brief
-
- › The Advantages
-
- › Technology Insights
-
- › The System
-
- › **Technical Specifications**
-
- › Service
-

Power Requirements

LSM 990 has a main power supply cord and plug, either NEMA L5-15 (100V – 125V) 2pol (15A) + PE or CEE blue (200 – 230V) 2pol (16A) + PE.

Line Voltage	1/N/PE 230 V AC (±10%)	1/N/PE 100 or 115 V AC (±10%)
Line Frequency	50/60 Hz	50/60 Hz
Leakage current	max. 7 mA at 230 V	max. 4 mA at 115 V

ZEISS LSM 990 incl. VIS Laser

Max. Current	7 A at 230 V	13 A at 120 V
Heat emission without Multiphoton Laser	1500 W max.	1500 W max.
Power Consumption	1600 VA max.	1500 VA max.

Multiphoton Laser

Power consumption and heat emission varies depending on type of laser. See data sheet of laser from laser supplier for further information.

FLIM add-on

Mains Input	2.5 A at 220 V AC	3.5 A at 120 V AC*
Nominal AC voltage L+N+PE	220–240 VAC (±10%)	100–127 VAC (±10%)
Nominal Frequency	50/60 Hz	50/60 Hz
Heat emission/ Power consumption	270 W	270 W

EMC test

according to DIN EN 61326-1

– Emitted interference according to CISPR 11 / DIN EN 55011

– Interference immunity as specified in Table 2 (industrial)

* Special rules apply in Canada

Technical specifications

- › In Brief
- › The Advantages
- › Technology Insights
- › The System
- › **Technical Specifications**
- › Service

Environmental Requirements

For operation the system has to be placed in a closed room.

1. Operation, specified performance	T = 22 °C ± 3 °C without interruption (24 h a day independently whether system is operated or switched-off) It has to be ensured that the air-flow of the air-conditioning is not directed at the system.
2. Operation, reduced performance	T = 15 °C to 35 °C, any conditions different from item 1. and 5.
3. Storage, less than 16 h	T = -20 °C to 55 °C
4. Temperature gradient	±0.5 °C/h
5. Warm up time	1 h, for high-precision and/or long-term measurements ≥ 3 h
6. Temperature gradient and range for continuous long-term image acquisition	± 1.5 °C/12 h
7. Relative humidity	<65 %
8. Operation altitude	max. 2000 m
9. Loss of heat (without Multiphoton Laser)	1.5 kW
10. Vibrations under operation conditions (with system table)	Vibration Class 12.5 µm/s VC-C (IEST RP 12 and ISO 10811)
11. Shipping shock (LSM 990 box)	< 10 g

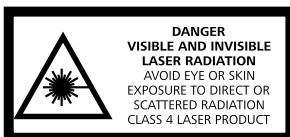

LSM 990 meets the requirements according to IEC 60825-1:2014

ZEISS Service – Your Partner at All Times

Your microscope system from ZEISS is one of your most important tools. For over 175 years, the ZEISS brand and our experience have stood for reliable equipment with a long life in the field of microscopy. You can count on superior service and support – before and after installation. Our skilled ZEISS service team makes sure that your microscope is always ready for use.

- › In Brief
- › The Advantages
- › Technology Insights
- › The System
- › Technical Specifications
- › **Service**

Procurement

- Lab Planning & Construction Site Management
- Site Inspection & Environmental Analysis
- GMP-Qualification IQ/OQ
- Installation & Handover
- IT Integration Support
- Startup Training

New Investment

- Decommissioning
- Trade In

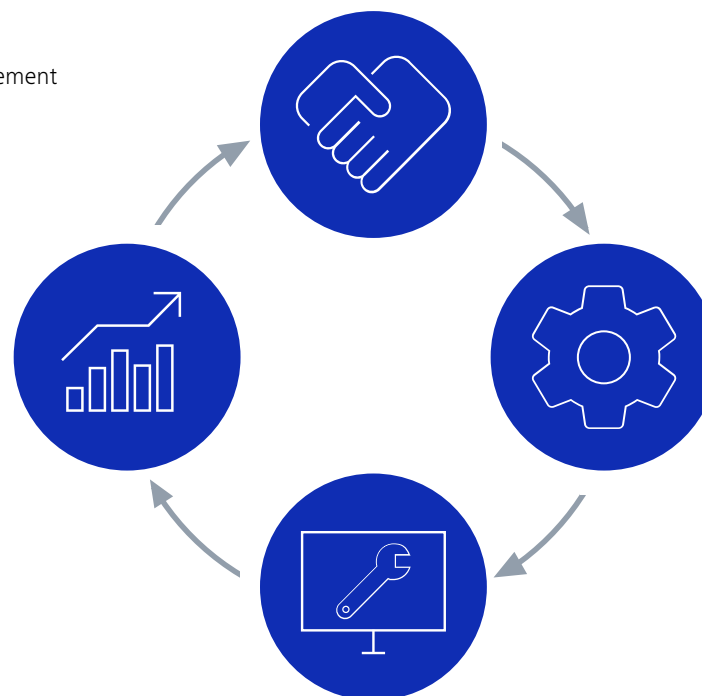

Operation

- Predictive Service Remote Monitoring
- Inspection & Preventive Maintenance
- Software Maintenance Agreements
- Operation & Application Training
- Expert Phone & Remote Support
- Protect Service Agreements
- Metrological Calibration
- Instrument Relocation
- Consumables
- Repairs

Retrofit

- Customized Engineering
- Upgrades & Modernization
- Customized Workflows via ZEISS arivis Cloud

Please note: Availability of services depends on product line and location

Get in touch:

www.zeiss.com/microscopy/service



Carl Zeiss Microscopy GmbH

07745 Jena, Germany
microscopy@zeiss.com

www.zeiss.com/lsm-990

Follow us on social media:

