

800'54 Ascend

- User Manual

Version 05



Copyright © by Bruker Corporation

All rights reserved. No part of this publication may be reproduced, stored in a retrieval system, or transmitted, in any form, or by any means without the prior consent of the publisher. Product names used are trademarks or registered trademarks of their respective holders.

© October 14, 2021 Bruker BioSpin AG

Document Number: ZTKS0239-05

P/N: Z31959

Contents

1	Introduction	5
1.1	Intended Use.....	5
1.2	Policy Statement.....	5
1.3	Installation and Initial Commissioning.....	5
1.4	Limitation of Liability.....	5
1.5	Warranty Terms.....	6
1.6	Customer Service.....	6
1.7	Product Safety and Electromagnetic Compatibility.....	6
2	Safety	7
2.1	Symbols and Conventions.....	7
2.2	Personnel Requirements.....	7
2.2.1	Qualifications.....	7
2.2.2	Unauthorized Persons.....	8
2.2.3	Instruction.....	8
2.3	System Owner's Responsibility.....	8
2.4	Residual Risks.....	10
2.4.1	Persons.....	10
2.4.2	Incorrect Use.....	10
2.4.3	Safety Devices.....	10
2.4.4	Spare Parts.....	11
2.4.5	Signs and Labels.....	11
2.4.6	Technical Risks.....	12
2.5	Description of Signs and Labels.....	15
2.6	Safety Devices.....	17
2.7	Behavior in Danger and Emergency Situations.....	18
2.8	Fire Department Notification.....	18
3	Packaging, Storage and Transportation	21
3.1	Packaging.....	21
3.2	Inspection at Delivery.....	22
3.3	Storage.....	22
3.4	Transportation.....	23
4	Design and Function	25
5	Operation	27
5.1	Set into Operation.....	27
6	Troubleshooting	29
6.1	During Transportation.....	29
6.2	During Assembly.....	29
6.3	During Cooling Procedure.....	31
6.4	During Energizing and Shimming.....	34
6.5	During Operation of the Magnet Stand.....	37
6.6	During Standard Operation.....	38

6.7	After a Quench.....	40
6.8	During Deenergizing and Warming.....	41
7	Maintenance.....	43
7.1	Cleaning.....	43
7.2	Maintenance Timetable.....	43
7.3	Maintenance-free Components.....	44
8	Dismantling and Disposal.....	45
8.1	Disposal in Europe.....	45
8.2	Disposal in USA and Other (non-EU) Countries.....	46
9	Technical Data 800'54 Ascend.....	47
9.1	Environmental Conditions.....	47
9.2	Identification Plate.....	47
9.3	Dimensions.....	48
9.3.1	Weights.....	48
9.3.2	Dimensions for Transportation.....	48
9.3.3	Dimensions Cryostat.....	49
9.4	Safety Valves.....	52
9.5	Nitrogen Level Sensor.....	53
9.6	Helium Level Sensor.....	54
9.7	Temperature Sensors.....	55
9.8	Magnet Technical Data.....	57
9.9	Fringe Field Plot.....	58
9.10	Filling Volume, Evaporation Rate and Hold Time.....	59
9.11	Nitrogen Level Graph.....	60
9.12	Helium Level Graph.....	61
9.13	Resistance at Room Temperature.....	62
9.14	Heater Currents.....	63
9.15	Shim Switch Heater.....	63
9.16	Energizing Assignment and Currents.....	64
9.17	Magnetic Center.....	65
9.18	Cycling Assignment and Shim Currents.....	66
9.19	Cryo Shim Currents.....	67
9.20	Deenergizing Assignment and Currents.....	67
9.21	Current Lead.....	69
9.21.1	Wiring Diagram Magnet.....	71
9.21.2	Wiring Diagram of Current Lead – Magnet Control and Shims.....	72
9.21.3	Wiring Diagram of Current Lead – Diagnostic and Temperature Sensors.....	73
9.21.4	Shorting Plug.....	74
9.22	Nitrogen Refill Report.....	75
9.23	Helium Refill Report.....	77
10	Contact.....	79
	List of Figures.....	81
	List of Tables.....	83
	Revision History.....	85

1 Introduction

This manual contains important information about the handling of the supplied magnet system used for NMR spectroscopy and its components. The compliance with all safety and handling instructions, the applicable local accident prevention and general safety regulations are necessary for safe work.

This manual is part of the product. It must be kept nearby the magnet system and free access must be ensured at any time. Read the manual carefully before handling the magnet system or its components.



Before starting any work, personnel must read the [safety instructions \[7 \]](#) in this manual thoroughly and understand the contents.

1.1 Intended Use

The supplied magnet system is designed and intended for NMR spectroscopy only.

Damage claims from damages caused by other than the intended use of the magnet system are excluded and the customer is held liable.

1.2 Policy Statement

Bruker's policy is to improve products as new techniques and components become available. Bruker reserves the right to change specifications at any time.

Every effort has been made to avoid errors in text and figure presentation in this publication. In order to produce useful and appropriate documentation, we welcome your comments on this publication. Field Service Engineers are advised to check regularly with Bruker for updated information.

Bruker is committed to providing customers with inventive, high-quality, environmentally-sound products and services.

1.3 Installation and Initial Commissioning



Installation, initial commissioning, retrofitting, repairs, adjustments or dismantling of the device must only be carried out by Bruker Service or personnel authorized by Bruker. Damage due to servicing that is not authorized by Bruker is not covered by warranty.

1.4 Limitation of Liability

All specifications and instructions in this manual have been compiled taking into account applicable standards and regulations, the current state of technology and the experience and insights we have gained over the years.

The manufacturer accepts no liability for damage due to:

- Failure to observe this manual.
- Improper use.
- Deployment of untrained personnel.

- Unauthorized modifications.
- Use of inadmissible spare parts.

The actual scope of supply may differ from the explanations and depictions in this manual in the case of special designs, take-up of additional ordering options, or as a result of the latest technical modifications.

The undertakings agreed in the supply contract, as well as the manufacturer's Terms and Conditions and Terms of Delivery, and the legal regulations applicable at the time of the conclusion of the contract shall apply.

1.5 Warranty Terms

The warranty terms are included in the manufacturer's Terms and Conditions.

1.6 Customer Service

Our customer service division is available to provide technical information. See the chapter [Contact](#) [p. 79] for contact information.

In addition, our employees are always interested in acquiring new information and experience gained from practical application; such information and experience may help improve our products.

1.7 Product Safety and Electromagnetic Compatibility

The device complies with the standard

- IEC 61010-1 and with UL 61010-1 / CSA C22.2 No. 61010-1-04 Safety Requirements for Electrical Equipment.
- IEC 61326-1 for Electromagnetic Compatibility (EMC)

2 Safety

The supplied cryostat and further equipment of the magnet system were designed and manufactured according to best available technical knowledge and practice, achieved in over 50 years of experience of the Bruker Corporation. International standards for quality and approval recommended for cryostats of superconducting magnets were certified.

Nevertheless non-compliance with the following instructions and safety advice may cause serious hazards and property damage.

2.1 Symbols and Conventions

Safety instructions in this manual have a clear structure based on the ANSI Z535.6 standard and conform with DIN EN 82079-1. They list the danger, consequences of non-compliance and possible solutions.

The safety instructions are introduced using indicative words which express the extent of the hazard.

In order to avoid accidents, personal injury or damage to property, always observe safety instructions and proceed with care.



DANGER indicates a hazardous situation that, if not avoided, will result in death or serious injury.



WARNING indicates a hazardous situation that, if not avoided, could result in death or serious injury.

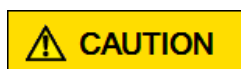

CAUTION indicates a hazardous situation that, if not avoided, could result in minor or moderate injury.



NOTICE is used to address practices not related to personal injury.

2.2 Personnel Requirements



Only trained Bruker personnel are allowed to install, mount, retrofit, repair, adjust and dismantle the unit!

2.2.1 Qualifications

This manual specifies the personnel qualifications required for the different areas of work, listed below:

Laboratory Personnel

Laboratory personnel are health care professionals, technicians, and assistants staffing a research or health care facility where specimens are grown, tested, or evaluated and the results of such measurements are recorded. Laboratory personnel are able to carry out assigned work and to recognize and prevent possible dangers independently due to their professional training, knowledge and experience as well as profound knowledge of applicable regulations.

The workforce must only consist of persons who can be expected to carry out their work reliably. Persons with impaired reactions due to, for example, the consumption of drugs, alcohol, or medication are prohibited from carrying out work on the device.

When selecting personnel, the age-related and occupation-related regulations governing the location used must be observed.

2.2.2 Unauthorized Persons

WARNING

Risk to life for unauthorized personnel due to hazards in the danger and work zone!



Unauthorized personnel who do not meet the requirements described in this manual will not be familiar with the dangers in the work zone. Therefore, unauthorized persons face the risk of serious injury or death.

- ▶ Unauthorized persons must be kept away from the danger and work zone.
- ▶ If in doubt, address the persons in question and ask them to leave the danger and work zone.
- ▶ Cease work while unauthorized persons are in the danger and work zone.

2.2.3 Instruction

Personnel must receive regular instruction from the owner. The instruction must be documented to facilitate improved verification, see the example form below.

Date	Name	Type of Instruction	Instruction Provided By	Signature

2.3 System Owner's Responsibility

System Owner

The term *system owner* refers to the person who operates the device for trade or commercial purposes, or who surrenders the device to a third party for use/application, and who bears the legal product liability for protecting the user, the personnel or third parties during the operation.

System Owner's Obligations

The device is used in the industrial sector, universities and research laboratories. The system owner of the device must therefore comply with statutory occupational safety requirements.

In addition to the safety instructions in this manual, the safety, accident prevention and environmental protection regulations governing the operating area of the device must be observed.

In this regard, the following requirements should be particularly observed:

- The system owner must obtain information about the applicable occupational safety regulations, and - in the context of risk assessment - must determine any additional dangers resulting from the specific working conditions at the usage location of the device. The system owner must then implement this information in a set of operating instructions governing operation of the device.
- During the complete operating time of the device, the system owner must assess whether the operating instructions issued comply with the current status of regulations and must update the operating instructions if necessary.
- The system owner must clearly lay down and specify responsibilities with respect to installation, operation, troubleshooting, maintenance and cleaning.
- The system owner must ensure that all personnel dealing with the device have read and understood this manual. In addition, the system owner must provide personnel with training and hazard information at regular intervals.
- The system owner must provide the personnel with the necessary protective equipment.
- The system owner must warrant that the device is operated by trained and authorized personnel as well as all other work, such as transportation, mounting, start-up, the installation, maintenance, cleaning, service, repair and shutdown, that is carried out on the device.
- All personnel who work with, or in the close proximity of the device, need to be informed of all safety issues and emergency procedures as outlined in this user manual.
- The system owner must document the information about all safety issues and emergency procedures in a laboratory SOP (Standard Operating Procedure). Routine briefings and briefings for new personnel must take place.
- The system owner must ensure that new personnel are supervised by experienced personnel. It is highly recommended to implement a company training program for new personnel on all aspects of product safety and operation.
- The system owner must ensure that personnel are regularly informed of the potential hazards within the laboratory. This is all personnel that work in the area, but in particular laboratory personnel and external personnel such as cleaning and service personnel.
- The system owner is responsible for taking measures to avoid inherent risks in the handling of dangerous substances, preventing industrial disease, and providing medical first aid in emergencies.
- The system owner is responsible for providing facilities according to the local regulations for the prevention of industrial accidents and generally accepted safety regulations according to the rules of occupational medicine.
- All substances needed for operating and cleaning the device samples, solvents, cleaning agents, gases, etc. have to be handled with care and disposed of appropriately. All hints and warnings on storage containers must be read and adhered to.
- The system owner must ensure that the work area is sufficiently illuminated to avoid reading errors and faulty operation.
- The system owner must ensure that the laboratory is equipped with an oxygen warning device, in case the device is operated with e.g. nitrogen or helium.

Furthermore, the system owner is responsible for ensuring that the device is always in a technically faultless condition. Therefore, the following applies:

- The system owner must ensure that the maintenance intervals described in this manual are observed.
- The system owner must ensure that all (electrical, mechanical, etc.) safety devices are regularly checked to ensure full safety functionality and completeness.

2.4 Residual Risks

In this section the residual risks from applicable risk analysis are summarized. To prevent health hazards and hazardous situations obey all safety instructions and warnings in the manual.

2.4.1 Persons

WARNING



Risk of injury and property damage due to handling by not approved persons.

Incorrect handling of the magnet system by not approved persons may result in significant bodily injury and property damage.

- ▶ Work must only be carried out by approved persons with applicable qualifications. The necessary qualifications are specified in the beginning of the relevant chapter.
- ▶ In case of doubt, contact Bruker Service.

2.4.2 Incorrect Use

WARNING



Risk of damage to life and limb by incorrect use of the magnet system.

Incorrect use of the magnet system can lead to life-threatening situations and destruction of the magnet system.

- ▶ Only use the magnet system as intended.
- ▶ Do not change the magnet system.
- ▶ Do not exceed specified values for operating the magnet system.
- ▶ Do not use inserts inside the RT bore not approved by Bruker Service.

2.4.3 Safety Devices

WARNING



Risk to life from nonfunctional or insufficient safety devices!

If safety devices are not functioning or are disabled, there is a danger of serious injury or death.

- ▶ Check that all safety devices are fully functional and correctly installed before starting work.
- ▶ Never disable or bypass safety devices.
- ▶ Ensure that all safety devices are always accessible.

2.4.4 Spare Parts

WARNING



Risk of injury or property damage from using incorrect or defective spare parts and accessories.

Incorrect or defective spare parts can cause serious injuries. They may cause damaging, malfunctioning and the destruction of the magnet system.

- ▶ Only use original equipment manufacturer spare parts.
- ▶ Only use original equipment manufacturer accessories.

2.4.5 Signs and Labels

WARNING



Risk of damage to persons and property due to not readable signs and labels.

Signs and labels may become not readable.

- ▶ Maintain signs and labels in a readable state.
- ▶ Replace damaged or not readable signs and labels immediately. New signs and labels can be obtained from Bruker Service.

2.4.6 Technical Risks

Magnetic Field

WARNING

Risk to life due to high magnetic fields

A magnetic field of more than 0.5 mT (5 Gauss) is life-threatening for people with pacemakers or active metal implants. Exposure to more than 8 T can cause damage to health. Duration of exposure (8 h/day) above the limit of 200 mT can cause damage to health. Ferromagnetic tools in the magnetic field are significantly hazardous. Hard discs and electronic devices may be damaged.

- ▶ Mark the magnetic field region of more than 0.5 mT (5 Gauss) before starting work, e.g. use masking tape on the floor.
- ▶ Keep people with active medical implants or heart pacemakers away from the 0.5 mT (5 Gauss) area.
- ▶ The permanent workplace of employees must be outside the 0.5 mT (5 Gauss) area.
- ▶ Do not stay or work at magnetic fields of more than 8 T.
- ▶ Prevent exposure of more than 200 mT for more than 8 h/day.
- ▶ Keep disks, credit cards and electronic devices away from the identified area.
- ▶ Do not use ferromagnetic tools or items within the identified area.
- ▶ Only use non-ferromagnetic transportation dewars or pressure cylinders for the cryogenic agents.
- ▶ Only use non-ferromagnetic ladders or steps.
- ▶ Remove ferro-magnetic items (jewelry, watches, pens etc.) before carrying out maintenance work.



Cryogenic Agents

WARNING

Risk of injury from cryogenic agents.

Risk of injury due to incorrect handling of liquid cryogenic agents. Within the transition from liquid to gas, helium and nitrogen expand their volume, causing closed vessels or transportation dewars to burst. The evaporating cryogenic agents will displace the breathing air. Helium displaces the breathing air in the upper part of the room; nitrogen displaces the breathing air in the lower part of the room. In case of not sufficient ventilation this may result in death by suffocation.

Liquid and gaseous cryogenic agents are extremely cold. Contact with liquid or gaseous cryogenic agents will lead to cold burns. Contact with the eyes may cause blindness.

- ▶ Only use cryogenic agents in well ventilated rooms. In case of doubt ask Bruker Service.
- ▶ Wear an oxygen monitor on the body during service and maintenance work.
- ▶ Prevent any skin contact with liquid or gaseous cryogenic agents.
- ▶ Avoid tipping over the liquid nitrogen container.
- ▶ Operators should be properly trained on the handling of liquid nitrogen.
- ▶ Warning signs should be in place on liquid nitrogen containers.



Electricity

 **WARNING****Risk to life due to electrical shock.**

Risk to life from electrical shock due to contact with electrical lines or damaged insulation.

- ▶ Work on electrical equipment must be done by an approved electrical technician.
- ▶ Keep moisture away from electrical lines to prevent short-circuits.
- ▶ Check the magnet system electrical grounding before start.

Quench

 **WARNING****Risk of suffocation during a quench of the magnet system.**

A quench is the very fast de-energizing of the magnet by loss of its superconductivity. The stored magnetic energy is converted into heat and thus large quantities of helium evaporate. The evaporating helium will displace the breathing air. In case of not sufficient ventilation this may result in death by suffocation.

- ▶ The magnet system site must be well ventilated. In case of doubt contact Bruker Service.
- ▶ The evaporating gas may resemble smoke. Never pour water on the magnet system.

Gas under Pressure

 **WARNING****Risk of injury due to gas under pressure inside the cryostat and further equipment.**

The helium or the nitrogen vessel of the cryostat may get sealed off due to ice formation inside the helium or the nitrogen turrets in case of non-compliance with the instruction given in this manual. This may lead to overpressure and to damage of the helium vessel or the nitrogen vessel.

Manipulations of components with gas under pressure may lead to injury and property damage.

- ▶ In case of ice inside the helium or the nitrogen turrets contact Bruker Service immediately.
- ▶ Release the pressure to the recommended value before working on components with gases under pressure.
- ▶ Do not seal cryogenic agent vessels of the magnet system or the transportation dewars.
- ▶ Do not connect high pressure transportation dewars to the magnet system. Completely eliminate the high pressure from the transportation dewars before connecting and transferring cryogenic agents.
- ▶ Always keep control of the maximum pressure during the nitrogen refilling procedure and during the helium refilling procedure.
- ▶ Do not exceed the maximum pressure of 0.35 bar in the nitrogen transportation dewar or 0.1 bar in the helium transportation dewar during the refilling procedure.

Low Temperatures

WARNING

Risk of injury due to low temperatures of liquids and metal parts.

Physical contact with extremely cold liquids and metal parts may cause serious injuries. Contact with the skin may cause cold burns. Contact with the eyes may cause blindness.



- ▶ Always wear protective goggles, protective gloves and protective clothes while handling with liquid cryogenic agents or metal parts in contact with liquid cryogenic agents.
- ▶ Only use specified hoses made of PFA (e.g. Teflon® PFA) for refilling.
- ▶ Protect temperature sensitive components such as O-rings from contact with liquid cryogenic agents.

Spontaneous Ignition and Explosion

WARNING

Risk of injury from spontaneous ignition and explosion caused by liquid oxygen.

Pure oxygen condenses on extremely cold metal pieces. Together with oil it may ignite spontaneously. In case of fire the pure oxygen may cause an explosion.



- ▶ Do not smoke near the magnet system.
- ▶ Do not use open flames near the magnet system.
- ▶ Keep the environment around the magnet system clean.
- ▶ Do not leave oily rags near the magnet system.

Risk of Slippage

WARNING

Risk of injury from slippage.

The accumulation of condensed water on the floor and ladders causes slippery surfaces.



- ▶ Always wear safety shoes with an anti-slip sole.
- ▶ Be careful using ladders.
- ▶ Clean floor and ladders regularly.

Risk of Tilting

WARNING

Risk of injury due to tilting of the magnet system.

The magnet system is very sensitive to lateral forces, it may tilt and fall.



- ▶ Do not climb onto the magnet system.
- ▶ Do not lean items against the magnet system.
- ▶ Do not lean against the magnet system.
- ▶ Do not move the magnet system on your own.

Heavy Weights

WARNING

Risk of injury or property damage when lifting heavy objects.

Lifting or moving heavy weights may be life-threatening due to falling or moving parts.



- ▶ Do not stay or work under a lifted magnet system.
- ▶ All lifting equipment in use must be approved to carry the weight.
- ▶ Do not use damaged lifting equipment.
- ▶ Do not use lifting equipment without updated check tag.
- ▶ Lifting only with approved qualification.
- ▶ Obey ergonomic guidelines while lifting heavy parts.
- ▶ Protect parts against falling.
- ▶ Always wear safety shoes with approved toe caps.

Transportation

CAUTION

Risk of injury and property damage due to incorrect transportation.

During transportation, boxes may tilt or move, resulting in material damage or injury.



- ▶ Be careful while unloading and moving the boxes.
- ▶ Do not move the boxes arbitrarily.
- ▶ Pay attention to all symbols on the boxes.
- ▶ Pay attention to sharp edges of boxes and parts and use protective gloves while moving.
- ▶ Move the boxes in an upright position, do not tilt the boxes.
- ▶ Prevent crossing thresholds, even if they are only a few millimeters high.
- ▶ Clear the transportation way before moving the box.
- ▶ Unpack shortly before assembling.
- ▶ The contents of the packaging must be protected from rain and other bad weather conditions during transportation.
- ▶ Only move the device in its original box.
- ▶ Do not remove the tightening straps inside the box until assembling.
- ▶ Only use the provided attachment points.
- ▶ Transport only with attached transportation locks.
- ▶ Do not move the assembled device.
- ▶ Do not move the device after cooldown.

2.5 Description of Signs and Labels

Signs and labels are always related to their immediate vicinity. The following signs and labels are found on the magnet system and in the vicinity.



Prohibition sign: No person with pacemakers!

People with pacemakers are endangered in the identified area of 0.5 mT (5 Gauss) and are not allowed to enter these areas.



Prohibition sign: No person with implants!

People with metallic implants are endangered in the identified area of 0.5 mT (5 Gauss) and are not allowed to enter these areas.



Prohibition sign: No watches or electronic devices!

Watches and electronic devices may be damaged in the identified area of 0.5 mT (5 Gauss).



Prohibition sign: No credit cards or other magnetic memory!

Credit cards and magnetic memory may be damaged in the identified area of 0.5 mT (5 Gauss).



Prohibition sign: Do not touch! Do not block!

Do not touch or block the identified area.



Hazard warning sign: Strong magnetic field!

- No magnetic memory.
- No jewelry.
- No metallic items.



Helium fill-in port

- Use only this port for helium refill!
- Do not leave the helium ports open for more than 5 seconds!



Emergency exit!

- Always keep the emergency exit clear.
- Follow the arrows if necessary.
- Doors must be pushed open in escape direction.



Protective Goggles (DIN EN 166, 170 & 172)

Protect your eyes from injury from cold gases, liquids and parts flying around. The safety label may be ordered using Bruker Part Number 23946.



Protective Gloves (DIN EN 388, 420 & 511)

Protect the hands from injury caused by contact with extremely cold gases, liquids or surfaces and for protection from injury caused by rough edges. The safety label may be ordered using Bruker Part Number 23947.



Protective Clothes

Used to protect the body from injury caused by contact with extremely cold liquids or surfaces and for protection from wounds.



Safety Shoes

Used to protect the feet from injury from falling of heavy objects. An anti-slip sole protects from injury caused by slipping and falling on slippery floor and steps. Only use safety shoes with non-ferromagnetic toe caps.

Portable Oxygen Monitor and Alarm

Used to warn against low oxygen concentrations in surrounding air.

2.6 Safety Devices

The supplied cryostat of the magnet system is equipped with the following safety devices:

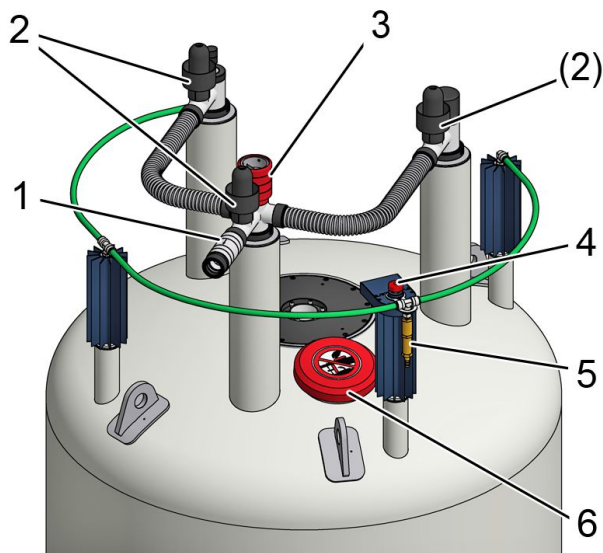

Figure 2.1: Safety Devices of the Cryostat with 3 Helium Turrets

1	One-Way Valve of the Helium Vessel	4	Safety Valve of the Nitrogen Vessel
2	Quench Valves	5	One-Way Valve of the Nitrogen Vessel
3	Bursting Disc	6	Drop-off Plate

Quench Valve

The quench valves (5) are the safety devices of the helium vessel. They open with a defined pressure. In case of an accidental overpressure in the helium vessel the quench valves will release the pressure smoothly.

Safety Valve

The safety valve (3) is the safety device of the nitrogen vessel. It opens with a defined pressure. In case of an accidental overpressure in the nitrogen vessel the safety valve will release the pressure smoothly.

Drop-off Plate

The drop-off plate (1) is a safety device of the RT vessel. If the vacuum breaks, the drop-off plate will open. In case of an accidental overpressure in the RT vessel the drop-off plate will release the pressure smoothly.

Bursting Disc

The bursting disc (6) is another safety device of the helium vessel only at cryostats with 3 helium turrets. It opens with a defined pressure. In case of an accidental overpressure in the helium vessel the bursting disc will release the pressure. It has to be replaced after an accident.

One-way Valves

The one-way valves of the nitrogen flow system (2) and of the helium flow system (4) keep air and moisture from entering the nitrogen vessel or the helium vessel in case of an accidental underpressure inside the vessels.

2.7 Behavior in Danger and Emergency Situations

Preparations

- Keep the emergency exits free at all times.
- Prepare and maintain an up-to-date list of emergency telephone numbers in the magnet system area.

In Case of Emergency

- Leave the danger zone immediately.
- Check for sufficient ventilation in the room before entering, especially if people are showing symptoms of suffocation.
- Rescue persons from the danger zone.
- Provide medical attention for people with symptoms of suffocation.
- Start first aid immediately.
- Call the responsible contact.
- Call for medical assistance.
- Call the fire department.

First Aid for Cold Burns

- Help the injured persons to lie down comfortably in a warm room.
- Loosen all clothing which could prevent blood circulation in the injured area.
- Pour large quantities of warm water over the affected parts.
- Cover the wound with dry and sterile gauze.
- In case of contact of liquid cryogenic agents with the eyes rinse thoroughly with clean water.
- Call for medical assistance.

2.8 Fire Department Notification

It is recommended that the magnet operator introduce the fire department and/or local authorities to the magnet site. It is important that these organizations be informed of the potential risks of the magnet system, e.g. that much of the magnetic rescue equipment (oxygen-cylinders, fire extinguishers, axe's etc.) can be hazardous close to the magnet system. In addition, their expertise and experience can be invaluable in creating an Emergency plan.

- In a NMR laboratory use only non-magnetic fire extinguishers.
- Breathing equipment which uses oxygen tanks made out of magnetic material can be life threatening when used close to a magnet system which is energized.
- During a quench helium gas escaping from the system must not be mistaken for smoke. Instruct the fire department and technical service not to "extinguish" the magnet system with water. The outlet valves could freeze and prevent the quench valves from closing.

- Laboratory windows which are accessible during an emergency must be clearly marked with warning signs, visible from the outside.

3 Packaging, Storage and Transportation

The transportation is carried out by Bruker Service or approved persons. However, it may happen that other persons have to receive the delivery of the shipping boxes. In this case it is essential to obey the instructions in this chapter and to inform these persons before.



Before starting any work, personnel must read the [safety instructions \[7 \]](#) in this manual thoroughly and understand the contents.

3.1 Packaging

The cryostat is supplied in a wooden box on a pallet. It is secured inside with straps against tilting and moving.

Accessories such as the flow systems, level sensors and bore tubes are in the side compartment of the box.

The Magnet Stand is supplied in a wooden box on a pallet.



Figure 3.1: Packaging (without surrounding panels)

Keep the original boxes for future transportation.

If no further transportation is planned, dispose of the boxes according to environmentally friendly regulations.

3.2 Inspection at Delivery

Investigate the delivery with regard to visible damage and completeness of delivery.

Transport control systems

The shipping and handling monitors (Shock Watch, Tilt Watch) on the boxes show if the boxes were kicked or tilted during transportation.

Checks

Shock Watch: Follow instructions on the label.

Tilt Watch: Follow instructions on the label.

In case of damage

- Accept delivery with reservation.
- Make a documentation of all observable damage and add it to the transportation documents.
- Start complaint process.
- Contact Bruker Service before installation.



The claim for damage expires after the fixed period.

Report damages to Bruker Service immediately after detection of damage. For contact information see [Contact \[p. 79\]](#) in this manual.

3.3 Storage

If it is necessary to store the cryostat and accessories before installation obey the following instructions:

- Store the boxes in a closed, dry and dust-free room.
- Store the boxes upright.
- Do not tilt the boxes.
- Do not unpack the supplied boxes.
- Prevent mechanical vibrations to the boxes.

Climatic Conditions for Storage & Transportation

- Store the packages according to the climatic conditions defined in IEC 60721-3-1, classification level 1K21.
- For the transportation, it is recommended to comply with the climatic conditions defined in IEC 60721-3-2, classification level 2K11.



Under certain circumstances, storage instructions may be affixed to packages that extend the requirements specified here. Comply with these accordingly.

3.4 Transportation

Transport and Rigging Safety

The following safety notices pertain to the transport and rigging of AVANCE NEO systems:

- The magnet should always be transported gently and in an upright position.
- The magnets are sensitive to shocks and tilting, thus are fitted with shock and tilt watches during transportation.
- Crates should not be left outside, but should be brought inside immediately to protect equipment.
- Only certified operators of fork lifts, pallet jacks and cranes should handle the transport and rigging.



For a relocation of NMR systems please contact your local Bruker Service office for further details and arrangements.

3.4.1 Transportation by Fork Lift / Pallet Jack

A fork lift is recommended for transporting the boxes to the installation site.

Approved Persons:

Approved fork lift / pallet jack operator

Precondition:

The fork lift / pallet jack must be approved for the transportation weight (refer to [Weights \[48\]](#)).



1. Check the route of transport for the minimal height and width.
2. Check sufficient floor capacity on the route of transport. In case of doubt ask a stress analyst.
3. Check sufficient carrying capacity while using an elevator.
4. Position the forks between the bars of the box as shown in the figure. Make sure the side towards the operator is the one with the labels on it.



5. Make sure the forks of the fork lift are longer than the box and project out of the back of the box as shown in the figure.
6. Now lift the fork and move the box to the site.

3.4.2 Transportation with a Crane

A crane is recommended for lifting the cryostat out of the box.

Approved Persons:

Approved crane operator

Precondition:

The crane must be approved for the transportation weight (see [Weights \[48\]](#)).

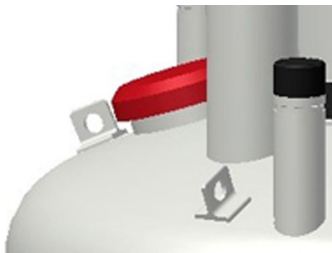

1. Exclusively use the marked eyelets as attachment points for the lifting equipment.
2. Use all eyelets for the lifting equipment.

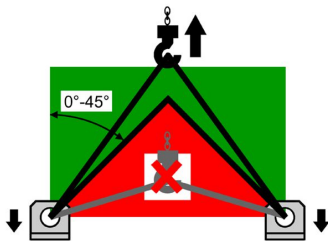

3. Follow the instructions on the label on top of the cryostat. This label gives important information about correct attachment and transportation.
4. Check for correct fastening of the lifting equipment before lifting the cryostat.
5. Make sure that any movement of the crane is as slowly as possible to avoid any damage due to acceleration.
6. Check for correct leveling of the cryostat while hanging on the crane.

4 Design and Function

The heart of the NMR magnet system is a superconducting magnet located inside the helium vessel, which is filled with liquid helium. The helium vessel is surrounded by a nitrogen vessel filled with liquid nitrogen. The outer casing, the room temperature (RT) vessel (2), contains the helium vessel and the nitrogen vessel. The vacuum in the RT vessel reduces thermal conduction. The RT bore (3) allows the access to the magnetic center. RT vessel, inner vessels, turrets, flow systems and the RT bore together build the cryostat of the magnet system. The cryostat is mounted on a magnet stand (1). The isolators in the magnet stand absorb floor vibrations. Different heights and isolators are available optionally.

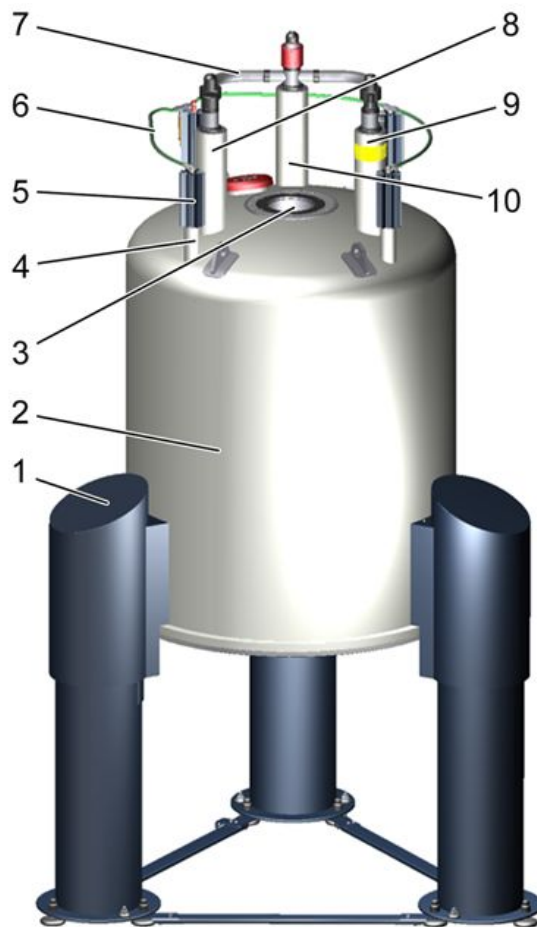

Figure 4.1: General View of a Magnet System with 3 Helium Turrets

1	Magnet Stand	6	Nitrogen Flow System
2	RT Vessel	7	Helium Flow System
3	RT Bore	8	High Current Lead Turret
4	Nitrogen Turrets	9	Helium Fill-in Turret with Helium Fill-in Port
5	Heat Exchanger	10	High Current Diagnostic Lead Turret

The nitrogen turrets (4) connected with the nitrogen flow system (6) and the heat exchangers (5) are the interface to the nitrogen vessel. The nitrogen fill-in turret is marked with a green label.

The helium turrets (8, 9) connected with the helium flow system (7) are the interface of the helium vessel and the magnet coil. The helium fill-in turret (9) is marked with a yellow label.

The current lead turret is the interface for energizing the magnet coil and for diagnostic.

At cryostats with three helium turrets the high current lead turret (8) builds the interface for energizing the magnet coil while the high current diagnostic lead turret (10) is for diagnostic only.

5 Operation



Before starting any work, personnel must read the [safety instructions \[▶ 7\]](#) in this manual thoroughly and understand the contents.

5.1 Set into Operation



Table 5.1: Start the Magnet Stand

If the magnet system is equipped with a magnet stand with pneumatic isolators:

Set the magnet stand into operation by switching the pneumatic controller to UP position.



Table 5.2: Stop the Magnet Stand

For any work at the magnet system like maintenance or refill of cryogenic agents stop the magnet stand by switching the pneumatic controller to DOWN position.

6 Troubleshooting

Troubleshooting must be performed only with approved qualification.

In case of doubts or problems not specified in the following list contact Bruker Service immediately. For contact information see [Contact \[p. 79\]](#) in this manual.



Before starting any work, personnel must read the [safety instructions \[p. 7\]](#) in this manual thoroughly and understand the contents.

6.1 During Transportation

Indicator	Possible reason	Solution	Performed by
Tilt Watch / Shock Watch activated.	Careless transportation.	<ol style="list-style-type: none"> 1. Accept delivery with reservation. 2. Remark the extent of damage in the transportation documents. 3. Start complaint process. 	Approved Customer Personnel
Visible damage.	Careless transportation.	<ol style="list-style-type: none"> 1. Accept delivery with reservation. 2. Remark the extent of damage in the transportation documents. 3. Start complaint process. 	Approved Customer Personnel

6.2 During Assembly

Indicator	Possible reason	Solution	Performed by
Ceiling height too low for assembly on magnet stand.	Site does not meet the required conditions.	Choose another site that meets the required conditions.	Bruker Service
Ceiling height too low for inserting the Helium Level Sensor.	Site does not meet the required conditions.	Insert the Helium Level Sensor before mounting the magnet stand.	Bruker Service

Table continued

Indicator	Possible reason	Solution	Performed by
Helium bore and radiation shield are not centered.	Alignment is not correct.	Check fitting of the alignment rods.	Bruker Service
	Alignment rod is loose or broken.	Replace alignment rod. ^a	Bruker Service
	Reduction flange is not centered.	Check the position of the reduction flange.	Bruker Service
Vacuum valve is touching the magnet stand.	Vacuum valve mounted incorrectly.	Reposition the vacuum valve.	Bruker Service
Vacuum in RT vessel does not reach 5×10^{-5} mbar within 48 hours.	O-rings may be damaged.	Check and clean O-rings and slots. If necessary, replace the O-rings for <ul style="list-style-type: none"> • the vacuum valve • the drop-off plate • the reduction and sealing flanges • the bottom plate. ^a 	Bruker Service
	Defective pumping unit or pumping line.	Check pumping unit and pumping line: A vacuum of at least 10^{-6} mbar must be reached while the sealing plug is closed. Replace if necessary.	Bruker Service
	Room temperature bore has scratches or dust on the sealing surfaces.	Check sealing surfaces on the RT bore: No scratches and no dust should be visible.	Bruker Service
	Moisture in the RT vessel.	Use dry N ₂ gas to pump and flush the RT vessel.	Bruker Service
Super insulation is touching the RT vessel or the RT bore or the radiation shield.	Super insulation was not attached correctly during assembling.	Attach the super insulation on the outer radiation shield using polyester tape. ^a Carefully prevent any contact of the vessels or the RT bore in the cryostat.	Bruker Service

a. This work requires to remove the bottom plate. Before removing the bottom plate check that the suspension tubes of the helium vessel are not broken. Install the safety device for fall protection (not supplied). Contact Bruker Service for further information.

6.3 During Cooling Procedure

Indicator	Possible reason	Solution	Performed by
Cooling with liquid nitrogen is too slow.	Empty transportation dewar.	Refill or replace transportation dewar.	Bruker Service
	Transfer pressure too low.	Increase transfer pressure slightly (max. pressure 0.3 bar).	Bruker Service
	Transportation dewar is leaky; no transfer pressure can be applied.	Check transportation dewar and replace if necessary.	Bruker Service
Precooling with liquid nitrogen occurs too quickly.	Transfer pressure too high.	Stop cooling. Adjust correct transfer pressure.	Bruker Service
Vacuum in RT vessel does not reach 5×10^{-5} mbar within 48 hours.	O-rings are leaky.	Check and clean O-rings and slots. If necessary, replace the O-rings for <ul style="list-style-type: none"> • the vacuum valve • the drop-off plate • the reduction and sealing flanges • the bottom plate.^a 	Bruker Service
	O-rings are frozen due to contact with liquid nitrogen.	<ol style="list-style-type: none"> 1. Stop cooling. 2. Warm O-rings with warm air. 3. Wait until the vacuum is recovered. 4. Prevent liquid nitrogen from splashing on O-rings. 	Bruker Service
	Pumping unit or pumping line is defective.	Check pumping unit and pumping line: A vacuum of at least 10^{-6} mbar must be reached while the sealing plug is closed. Replace if necessary.	Bruker Service

a. This work requires to remove the bottom plate. Before removing the bottom plate check that the suspension tubes of the helium vessel are not broken. Install the safety device for fall protection (not supplied). Contact Bruker Service for further information.

Table continued

Indicator	Possible reason	Solution	Performed by
RT vessel becomes cold and wet.	Vacuum is broken or less than 10^{-3} mbar.	<ul style="list-style-type: none"> Keep the pumping unit connected until filling with liquid helium is finished. Continue as in problem <i>Vacuum in RT vessel does not reach 10^{-6} mbar.</i> 	Bruker Service
	Cold leak after transportation.	<ol style="list-style-type: none"> Stop cooling. Warm the cryostat. 	Bruker Service
Cold spot in the RT bore.	Alignment not correct.	<ol style="list-style-type: none"> Stop cooling. Warm the cryostat. Align the vessels. 	Bruker Service
The helium flow system becomes very cold and icy during flushing with helium gas.	Liquid nitrogen remains in the helium vessel, boiling off strongly during flushing.	<ol style="list-style-type: none"> Stop flushing. Carefully remove all liquid nitrogen using the precooling tube. Use the dipstick to check that the helium vessel is empty (no liquid nitrogen or frozen nitrogen). 	Bruker Service
After some intervals of flushing it is not possible to reach a vacuum in the range of 1 mbar.	The globes in the quench valves are not fitting correctly in the O-rings and thus the quench valves are leaky.	<ol style="list-style-type: none"> Stop pumping. Remove frozen air and frozen moisture using warm helium gas. Apply a small amount of grease to the O-rings and check the position of the globes. Use the dipstick to check that the helium vessel is empty (no liquid nitrogen or frozen nitrogen). 	Bruker Service
	Liquid nitrogen remains in the helium vessel, boiling off strongly during flushing.	<ol style="list-style-type: none"> Stop pumping. Use the precooling tube to remove all liquid nitrogen. Use the dipstick to check that the helium vessel is empty (no liquid nitrogen or frozen nitrogen). 	Bruker Service

Table continued

Indicator	Possible reason	Solution	Performed by
Nitrogen ice in the helium vessel.	Times between pumping and flushing were too long. Nitrogen boiled off during pumping and remaining nitrogen got frozen during flushing.	<ol style="list-style-type: none"> 1. Warm the magnet coil with warm helium gas by using the precooling tube until the whole coil is at 90 K or above. 2. Repeat pumping and flushing. 3. Use the dipstick to check that the helium vessel is empty (no liquid nitrogen or frozen nitrogen). 	Bruker Service
Transfer of liquid helium does not start.	The transportation dewar is empty.	Refill or replace transportation dewar.	Bruker Service
	The transfer pressure in the transportation dewar is too low.	Increase the transfer pressure.	Bruker Service
	The transportation dewar is leaky, no transfer pressure is built up.	Check the transportation dewar for leakage. Re-tighten all connections.	Bruker Service
	The siphon or the helium transfer line are blocked with ice.	Check the siphon and helium transfer line for blockages. Remove ice with warm helium gas.	Bruker Service
The cooling of the magnet coil does not continue although helium is transferred.	The helium transfer line is defective.	Check the helium transfer line for ice. If there are cold spots visible, replace the helium transfer line.	Bruker Service
	The extension piece is not mounted on the helium transfer line.	Mount the extension piece on the helium transfer line. Check the helium transfer line is completely inserted in the siphon.	Bruker Service
The zero reading of the Helium Level Sensor cannot be adjusted at the beginning of cooling with liquid helium.	The Helium Level Sensor is not connected correctly with the connector in the helium flow system.	Check the connection in the helium fill-in turret between Helium Level Sensor and connector.	Bruker Service
	The Helium Level Sensor is defective.	Check the Helium Level Sensor using the 0 % calibration plug.	Bruker Service

Table continued

Indicator	Possible reason	Solution	Performed by
The helium level does not reach 100 % after cooling.	Empty transportation dewar, helium transfer stopped.	Refill or replace transportation dewar.	Bruker Service
	The Helium Level Sensor is disturbed by the transfer line's extension piece.	<ol style="list-style-type: none"> 1. Stop the liquid helium transfer. 2. Remove the transfer line. 3. Wait for a few minutes. 4. Measure the helium level to check the Helium Level Sensor is working correctly. 	Bruker Service
After cooling the rate of helium boil off is higher than specified (up to 5 times).	Usual behavior. A few days are necessary for the radiation shields and the insulation to reach scheduled temperatures.	<p>Wait a few days and check helium boil off.</p> <p>The presence of the current lead in the current lead turret during energizing and shimming helps cooling the radiation shield due to higher helium flow.</p>	Bruker Service

6.4 During Energizing and Shimming

Indicator	Possible reason	Solution	Performed by
The current lead cannot be inserted completely into the connector.	The connector is covered with ice (frozen moisture or nitrogen ice).	Carefully remove the ice with warm helium gas. Use the dipstick or the precooling tube as tubing for the warm helium gas to remove small ice spots.	Bruker Service
	The shorting plug was not removed.	Remove the shorting plug with the shorting plug tool.	Bruker Service
	The orientation of the current lead is not correct.	Carefully reposition the current lead until it can be inserted correctly into the connector.	Bruker Service
Main coil heater test fails.	Power supply defective.	Replace the power supply.	Bruker Service
	Connector or cables defective.	Clean connectors or replace cables, if necessary.	Bruker Service

Table continued

Indicator	Possible reason	Solution	Performed by
Setting of sense voltage fails.	The main coil heater switch is "OFF". The main coil switch is not opened.	Switch the main coil heater to "ON" and check the main coil heater current to be adjusted correctly.	Bruker Service
	The main coil heater current is not correct. The main coil switch is not opened.	Adjust main coil heater current correctly.	Bruker Service
	The auxiliary shorting plug is inserted in the current lead turret by mistake and makes a short circuit across the main coil.	Remove the auxiliary shorting plug and insert it in the helium fill-in turret.	Bruker Service
Current lead cannot be removed.	The connector is covered with ice (frozen moisture or nitrogen ice).	Carefully remove the ice with warm helium gas over the helium flow system. Use the dipstick or the precooling tube as tubing for the warm helium gas to remove small ice spots from the connector.	Bruker Service
Shorting plug cannot be removed.	The connector is covered with ice (frozen moisture or nitrogen ice).	Carefully remove the ice with warm helium gas. Use the dipstick or the precooling tube as tubing for the warm helium gas to remove small ice spots from the connector.	Bruker Service
The magnet system quenches.	Loss of superconductivity.	See After a Quench [▶ 40].	Bruker Service
	The helium level was too low for energizing, cycling, shimming, deenergizing or sweeping.	See After a Quench [▶ 40].	Bruker Service
	The power supply is defective. The main current is oscillating.	Replace the power supply.	Bruker Service

Table continued

Indicator	Possible reason	Solution	Performed by
The main coil switch cannot be closed on field.	The helium level is too low for energizing. The main coil switch is not covered with liquid helium.	Never try to energize the magnet with a helium level less than the "minimum level during energizing" in the helium vessel.	Bruker Service
	The power supply is defective. The main current is oscillating.	Replace the power supply.	Bruker Service
Shim current cannot be set correctly.	The control cable is not connected correctly to the current lead or to the power supply.	Connect the control cable correctly to the current lead and to the power supply.	Bruker Service
	The switch „Main Coil/OFF/Shim Coil“ is in the wrong position.	Change the switch position.	Bruker Service
Shims do not affect the NMR signal.	Shim heater current is not correct. The shim switches are not opened.	Set the shim heater current to the specified value (see Energizing Assignment and Currents [▶ 64]).	Bruker Service
Magnet system does not reach specification.	Magnetic material inside RT bore tube.	Carefully clean the RT bore tube.	Bruker Service
	Large ferromagnetic parts near the magnet system.	<ol style="list-style-type: none"> As much as possible, keep all ferromagnetic parts away from the magnet system. Repeat shimming. 	Bruker Service

6.5 During Operation of the Magnet Stand

More information is available in the Magnet Stand manual.

Indicator	Possible reason	Solution	Performed by
The NMR spectrum shows massive disturbances.	Pneumatic controller is in DOWN position.	Switch pneumatic controller to UP position.	Approved Customer Personnel
	Magnet system is touching the floor via accessories or cables.	Identify and eliminate contact point. Arrange cables in loose S- or U-shapes.	Approved Customer Personnel
		If the problem is still not solved, contact Bruker Service.	Approved Customer Personnel
	Magnet system is touching the magnet stand.	Check the level; adjust if necessary.	Approved Customer Personnel
	Piston of the isolator is not centered or is touching its casing.	Align magnet stand.	Bruker Service
	T-safety bracket is touching the pillar.	Align magnet stand.	Bruker Service
	Floor vibrations in vertical direction.	Replace elastomeric isolators with air damped isolators.	Bruker Service
	Floor vibrations in horizontal and vertical direction.	Replace air damped isolators with air piston isolators.	Bruker Service
The pneumatic isolator of the magnet stand does not reach the operating position.	Pneumatic controller in DOWN position.	Switch pneumatic controller to UP position.	Approved Customer Personnel
	The pressure of the gas supply is too low.	Check the pressure of the pneumatic supply. It must be in the range of 5 to 8 bar (70 to 112 psi).	Approved Customer Personnel
		If the problem is still not solved, contact Bruker Service.	Approved Customer Personnel

Table continued

Indicator	Possible reason	Solution	Performed by
The pneumatic isolator of the magnet stand does not reach the operating position.	The magnet system is not level.	Stop the pneumatic isolators. Check the level of the cryostat.	Bruker Service
	Defective leveling valve.	Replace leveling valve or isolator.	Bruker Service
	Defective membrane of an isolator.	Replace leveling valve or isolator.	Bruker Service
The movement of the magnet stand is not smooth.	Piston is not centered or is touching its casing.	Align magnet stand.	Bruker Service
Audible loss of gas.	Defective membrane or defective leveling valve of an isolator.	Replace leveling valve or isolator.	Bruker Service
	Hose connector is defective or loose.	Insert hoses correctly and tighten screws.	Bruker Service
The movement of the magnet stand is too fast.	Incorrect adjustment of the flow control valve.	Close fully the flow control valve; then open ½ turn.	Bruker Service

6.6 During Standard Operation

Indicator	Possible reason	Solution	Performed by
The helium boil off decreases to zero.	The atmospheric pressure is increasing.	Usual behavior. Check the helium boil off daily.	Approved Customer Personnel
	The helium flow system is covered with ice.	Contact Bruker Service immediately! Do not try to remove ice from the helium flow system!	Approved Customer Personnel
	The helium flow system or the suspension tubes are blocked with ice.	Flush warm helium gas through an applicable tube. Do not insert the tube more than 600 mm from the top of the helium turrets.	Bruker Service
The helium boil off is too high.	The Helium Level Sensor is in service mode or has been used too often.	Switch off Helium Level Sensor. Reduce frequency of helium level measurement (during measuring of the helium level an amount of helium boils off due to the heat input of the Helium Level Sensor).	Approved Customer Personnel

Table continued

Indicator	Possible reason	Solution	Performed by
The helium boil off is too high.	The atmospheric pressure is decreasing.	Usual behavior. Check the helium boil off daily.	Approved Customer Personnel
		If it continues, contact Bruker Service.	Approved Customer Personnel
	Vacuum reduced.	Rebuild vacuum, see chapter <i>Rebuilding Vacuum</i> in the service manual.	Bruker Service
	The radiation baffles are not inserted in the current lead turret.	Insert the radiation baffles into the current lead turret.	Bruker Service
Quench.	Loss of superconductivity.	See After a Quench [40] . Contact Bruker Service immediately!	Approved Customer Personnel
Cold spots in the RT bore.	Alignment of the vessels not correct.	Contact Bruker Service.	Approved Customer Personnel
RT vessel is wet and cold.	Vacuum reduced.	Contact Bruker Service immediately!	Approved Customer Personnel
Helium level warning out of MICS is false.	Helium Level Sensor defective.	Contact Bruker Service immediately!	Approved Customer Personnel
Helium level at constant level, no change during days.	Helium Level Sensor defective.	Contact Bruker Service immediately!	Approved Customer Personnel
Helium level warning out of MICS is false.	Helium Level Sensor defective.	Replace Helium Level Sensor (see chapter <i>Replacement of the Helium Level Sensor</i> in the service manual).	Approved Customer Personnel
Helium level at constant level, no change during days.	Helium Level Sensor defective.	Replace Helium Level Sensor (see chapter <i>Replacement of the Helium Level Sensor</i> in the service manual).	Approved Customer Personnel

6.7 After a Quench

A quench is the very fast deenergizing of the magnet by loss of its superconductivity. The stored magnetic energy is converted into heat, which promotes rapid evaporation of large quantities of helium. If a quench occurs, contact Bruker Service immediately.



Figure 6.1: Magnet system during a quench

1. Wait until helium stops evaporating and the quench valves are closed.
2. Wait until there is no helium vapor visible anywhere to make sure there is sufficient oxygen in the room.
3. Check that the globes in the quench valves are in the correct position.
4. Remove probe and shim system to prevent formation of ice on the shim system.
5. Start the refill with liquid helium as soon as possible.
6. Contact Bruker Service immediately.

6.8 During Deenergizing and Warming

Indicator	Possible reason	Solution	Performed by
The magnet system quenches during deenergizing.	The helium level was too low for deenergizing.	Refill helium at least to the minimum allowed level.	Bruker Service
	The power supply is defective.	Replace power supply.	Bruker Service
	The main current is oscillating.	Replace power supply.	Bruker Service
The shim current cannot be set correctly.	The control cable is not connected correctly to the current lead and/or the power supply.	Connect the control cable to the current lead and to the power supply correctly.	Bruker Service
	The switch "Main Coil/OFF/Shim Coil" is not on the "Shim Coil" position.	Switch "Main Coil/OFF/Shim Coil" to the "Shim Coil" position.	Bruker Service
High helium flow after breaking vacuum.	Remaining cryogenic agents in the vessels.	Remove liquid cryogenic agents.	Bruker Service
Vacuum still remains after 12 hours.	Vacuum valve is closed.	Open the vacuum valve. Block it if necessary.	Bruker Service
RT vessel is wet and cold.	Cryostat is still cold.	Wait until RT vessel is dry and warm. Check PT 100 temperature sensors.	Bruker Service
RT bore is wet and cold before disassembling.	Cryostat is still cold.	Wait one more day. Do not open a cryostat before the room temperature bore tube is warm and dry!	Bruker Service

7 Maintenance



Before starting any work, personnel must read the [safety instructions \[7 \]](#) in this manual thoroughly and understand the contents.

7.1 Cleaning

- Clean the RT vessel of the magnet system and the magnet stand with a dry or slightly damp cloth.
- Only use water and neutral detergents.
- Do not use volatile cleaning solvents.

7.2 Maintenance Timetable

Interval	Device	Work	Performed by
Daily	Cryostat	Check the helium flow.	Approved Customer Personnel
Daily	Cryostat	Check the nitrogen flow.	Approved Customer Personnel
Weekly	Cryostat	<ul style="list-style-type: none"> • Check the helium level. • Refill liquid helium if necessary. Follow the safety instructions of the supplied manual <i>Refilling Procedure (Z31326)</i>. • Record the filling session. A record of the changes in the estimated consumption may be used for identification of problems. In this case contact Bruker Service. 	Approved Customer Personnel
Weekly	Cryostat	<ul style="list-style-type: none"> • Check the nitrogen level. • Refill liquid nitrogen if necessary. Follow the safety instructions of the supplied manual <i>Refilling Procedure (Z31326)</i>. • Weekly refill of liquid nitrogen is recommended. • Record the filling session. A record of the changes in the estimated consumption may be used to identify problems. In this case contact Bruker Service. 	Approved Customer Personnel

Table 7.1: Maintenance timetable

7.3 Maintenance-free Components

Interval	Device	Work	Performed by
- - -	Quench valves	The quench valves are maintenance-free. <ul style="list-style-type: none">• However, in the event of a quench check the correct position of the globes in the quench valves.	Approved Customer Personnel

Table 7.2: Maintenance-free components of the magnet system

8 Dismantling and Disposal

Following the end of its operational life, the device must be dismantled and disposed of in accordance with the environmental regulations.



Installation, initial commissioning, retrofitting, repairs, adjustments or dismantling of the device must only be carried out by Bruker Service or personnel authorized by Bruker. Damage due to servicing that is not authorized by Bruker is not covered by warranty.

8.1 Disposal in Europe

Environmental information for laboratory and industrial customers within the EU (European Union)



This laboratory product is developed and marketed for Business-to-Business (B2B), so does not fall under article 6 clause 3 of the German Act ElectroG. To meet the demands of the European Directive 2012/19/EU WEEE 2 (Waste of Electrical and Electronic Equipment) and the national Equipment Safety Act, electrical and electronic equipment that is marked with this symbol directly on or with the equipment and/or its packaging must not be disposed of together with unsorted municipal waste or at local municipal waste collecting points. The symbol indicates that the equipment should be disposed of separately from regular industrial/ domestic waste.

Correct disposal and recycling will help prevent potential negative consequences for the environment and risk to personal health. It is your responsibility to dispose of this equipment using only legally prescribed methods of disposal and at collection points defined by government or local authorities in your area.

The WEEE register number can be found on the product label of the equipment. If you need further information on the disposal of equipment or collection and recovery programs available, contact your local Bruker BioSpin sales representative. Local authorities or professional waste management companies may also provide information on specific waste disposal services available in your area.

Disposal - End of Life (EoL) information

After the lifespan of an electrical and electronic product, Bruker BioSpin takes responsibility for final disassembly and correct disposal in accordance with the European directive WEEE 2012/19/EU.

Bruker BioSpin offers to take back the equipment (only for deliveries after 23.03.2006) after termination of use at the customer site upon request by the customer. Additional costs for dismantling and transport service will apply!

Only 100% pre-decontaminated equipment can and will be accepted by Bruker BioSpin. A release document for decontamination (Equipment Clearance Form) can be requested from your nearest Bruker BioSpin contact site, following the Return Material Acceptance (RMA) process when repairs, going back to Bruker sites, are requested.

In compliance with WEEE II directive: **2012/19/EU**

8.2 Disposal in USA and Other (non-EU) Countries

Disposal of these materials may be regulated due to environmental considerations. For disposal or recycling information, please contact our local office or your local authorities, or in the U.S.A., contact the Electronics Industry Alliance web site at www.eiae.org.

9 Technical Data 800'54 Ascend

9.1 Environmental Conditions

	Value	Unit
Minimum surrounding temperature	17	°C
Maximum surrounding temperature	35	°C
Maximum relative humidity up to 31°C	80	%
Maximum relative humidity between 31°C and 40°C linearly decreasing	80 - 50	%

Table 9.1: Environmental Conditions

9.2 Identification Plate

The identification plate is on the right rear side attached to the bottom plate of the cryostat.

Contents of the identification plate:

- Address of the Manufacturer
- Magnet System Identifier
- Type
- Magnet Identifier
- Serial Number
- Year of Construction
- Cryostat Identifier
- Specification Helium Vessel
- Specification Nitrogen Vessel
- Specification Vacuum Chamber
- Weight (empty and completely filled) including magnet stand

9.3 Dimensions

9.3.1 Weights

	Value	Unit
Weight magnet system (empty, without magnet stand)	1777	kg
Weight magnet system (completely filled, without magnet stand)	1997	kg
Operational weight (completely filled, with magnet stand)	2170	kg
Weight magnet stand	173	kg
Weight magnet stand (ready for transportation, including box)	264	kg
Weight magnet system (empty, ready for transportation, including box)	2075	kg

Table 9.2: Weight

9.3.2 Dimensions for Transportation

	L x W x H	Unit
Magnet box	151 x 129 x 218	cm ³
Magnet stand box	132 x 77 x 132	cm ³

Table 9.3: Dimensions for Transportation of the Magnet System

9.3.3 Dimensions Cryostat

Front View

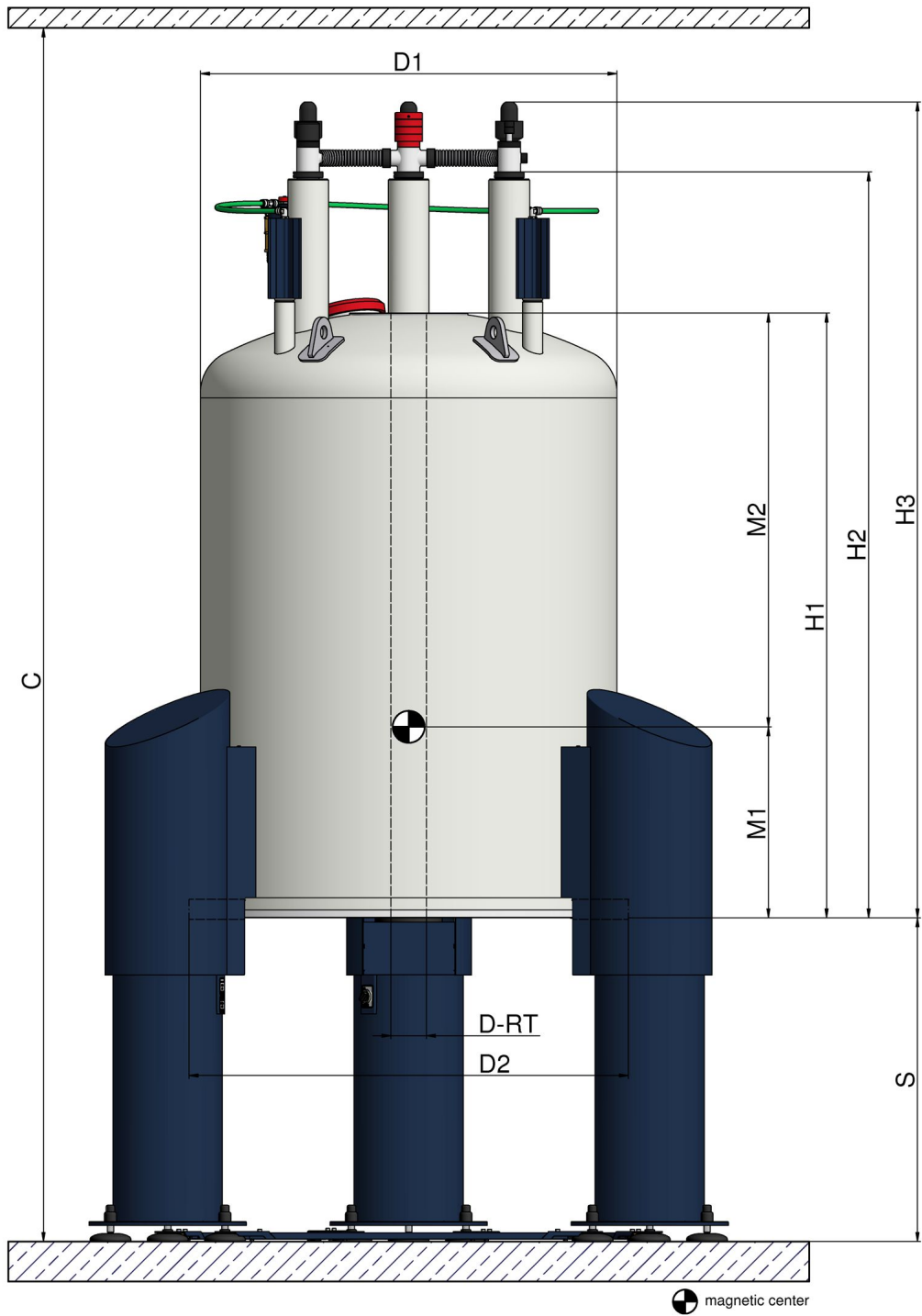

Figure 9.1: Dimensions of the Cryostat (front view)

	Value	Unit
C: Operational Ceiling Height	3250	mm
D-RT: Diameter RT Bore Tube	54	mm
D1: Diameter RT Vessel	1040	mm
D2: Diameter Bottom Plate	1100	mm
H1: Height Cryostat (bottom plate to top flange)	1510	mm
H2: Height Cryostat (minimum height for transportation)	1861	mm
H3: Height Cryostat (bottom plate to flow system)	2038	mm
S: Height Magnet Stand (floor to bottom plate)	800	mm
MCB: Distance magnetic center to bottom flange (calculated)	512	mm
MCT: Distance magnetic center to top flange (calculated)	998	mm

Table 9.4: Dimensions of the Cryostat (front view)



Refer to the table in section [Magnetic Center \[▶ 65\]](#) for the measured distance of the magnetic center to bottom flange (MCB) and for the measured distance of the magnetic center to top flange (MCT).

Top View

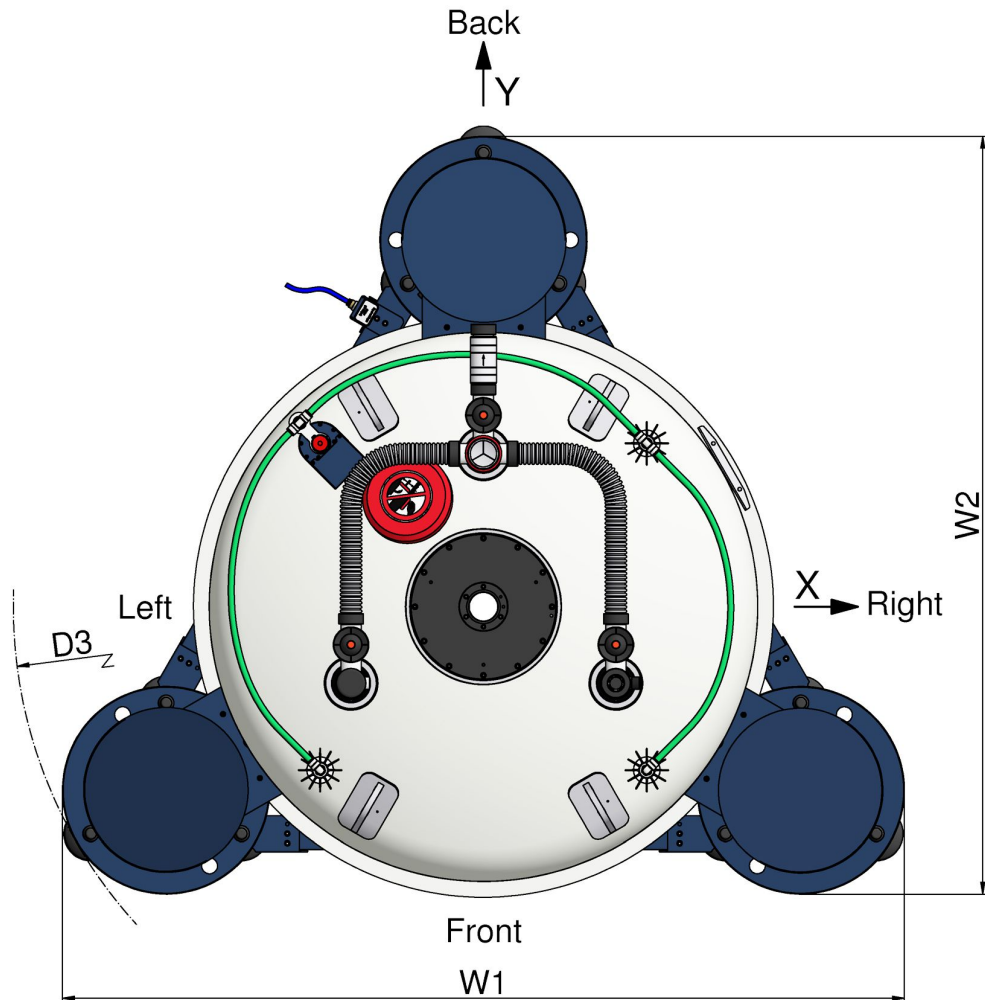

Figure 9.2: Dimensions of the Cryostat (top view)

	Value	Unit
W1	1597	mm
W2	1435	mm
D3	1783	mm

Table 9.5: Dimensions of the Cryostat (top view)



Keep at least an additional free space of 1.5 m around the magnet system for service.

9.4 Safety Valves

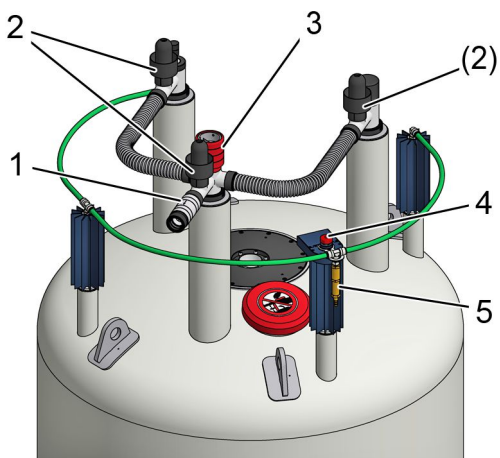

Figure 9.3: Safety Devices of the Cryostat with 3 Helium Turrets

1	One-way valve of the helium vessel	4	Safety valve of the nitrogen vessel
2	Quench valve	5	One-way valve of the nitrogen vessel
3	Bursting disc		

Opening Pressure	mbar	psi
One-way valve of the nitrogen vessel	10	0.15
Safety valve of the nitrogen vessel	138	2
One-way valve of the helium vessel	15	0.22
Quench valve	180	2.6
Bursting disc	600	8.7

Table 9.6: Opening Pressure of the Safety Valves of the Magnet System

9.5 Nitrogen Level Sensor

The Nitrogen Level Sensor is inserted in the recommended nitrogen turret. Five lights display the nitrogen level (see figure below).

	Value	Unit
Level sensor type	12/1431/1160 D366	
Part number	Z135599	
Diameter	12	mm
Overall length	1431	mm
Active length	1160	mm

Table 9.7: Nitrogen Level Sensor

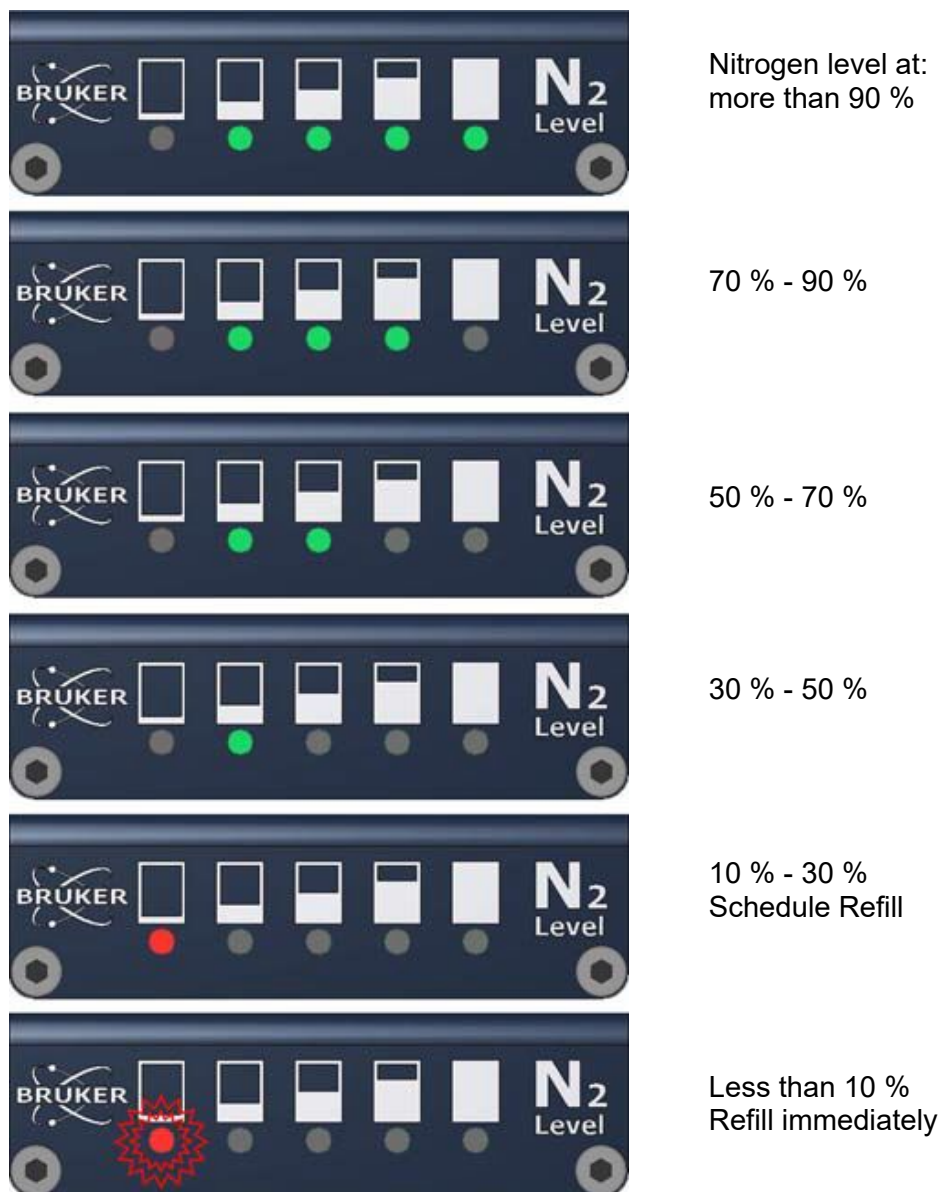

Figure 9.4: Nitrogen Level Sensor

9.6 Helium Level Sensor

The Helium Level Sensor is inserted in the helium fill-in turret.

	Value	Unit
Part number	Z58103	
Level sensor type	1500/874 D37X	
Overall length	1500	mm
Active length	874	mm
Calibration 0 %, calibration resistor	177	Ω
Calibration 0 %, calibration resistor part number	Z53168 - violet	
Calibration 100 %, calibration resistor	15	Ω
Calibration 100 %, calibration resistor part number	Z28628 - black	

Table 9.8: Helium Level Sensor

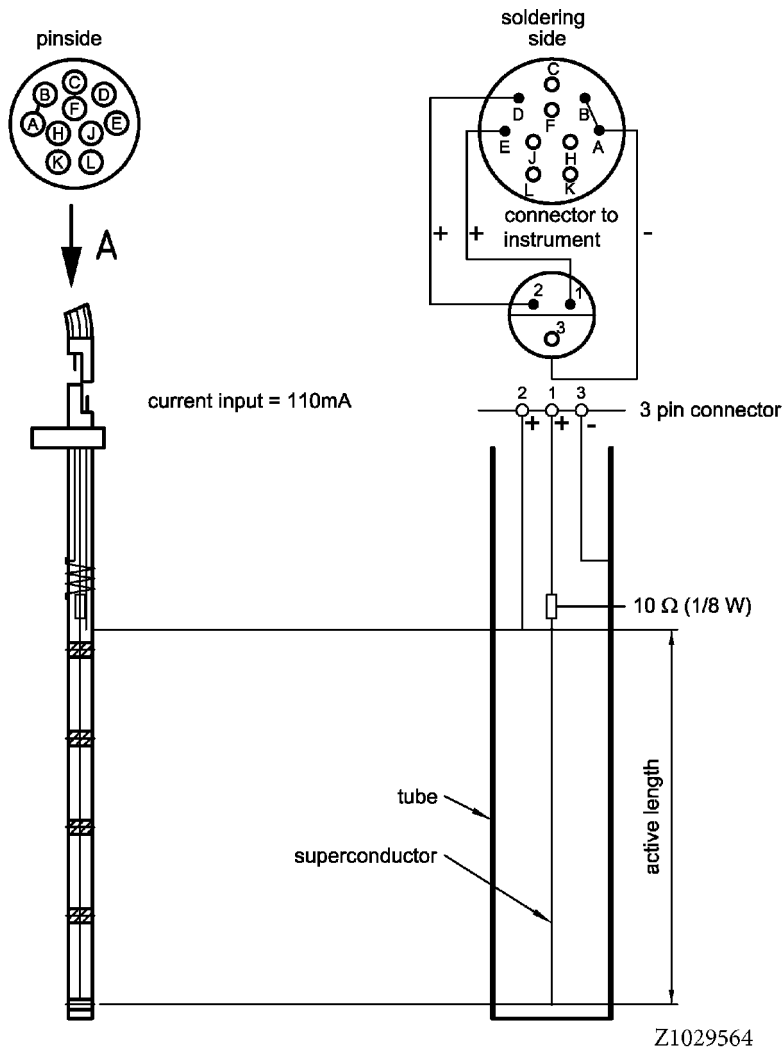

Figure 9.5: Helium Level Sensor

9.7 Temperature Sensors

The temperature sensors (PT100 and Carbon Composition Resistors) are used to monitor the temperature of the magnet during cooling down and warming up the magnet system.

PT 100 Sensor



Measure the resistance with a maximum current of 1 mA.

	Temperature	Unit	Resistance	Unit
Room Temperature	293	K	107.8	Ω
	273	K	100.0	Ω
	250	K	91.0	Ω
	200	K	71.1	Ω
	150	K	50.9	Ω
	100	K	30.0	Ω
Liquid Nitrogen	77	K	20.1	Ω

Table 9.9: Characteristic Values of the PT 100 Sensor

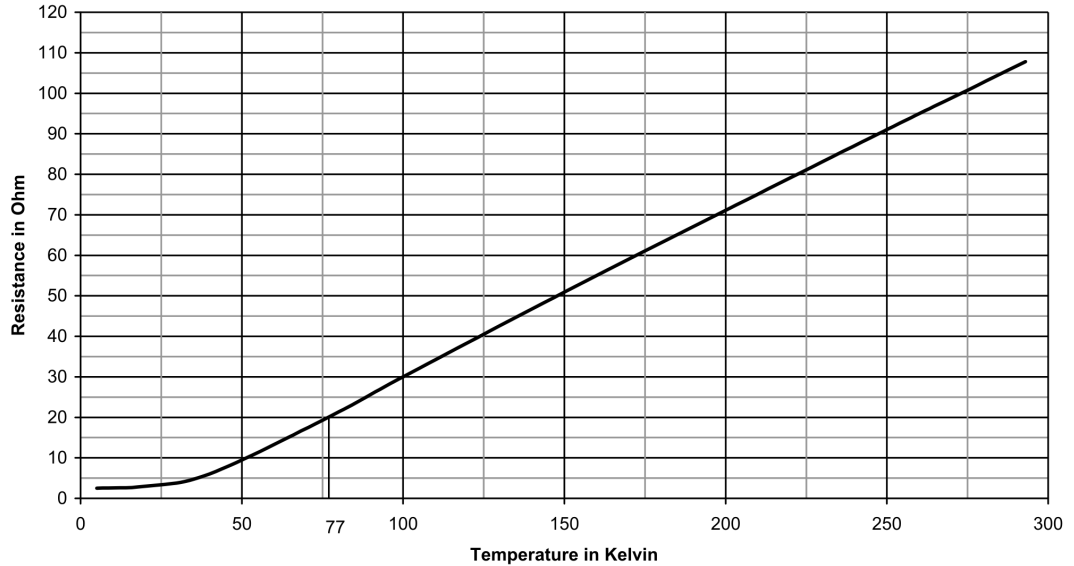

Figure 9.6: Characteristic Curve of the PT 100 Sensor

Carbon Composition Resistor



Measure the resistance with a maximum current of 0.1 mA.

	Temperature	Resistance
Room Temperature	300 K	209 ... 231 Ω
Liquid Nitrogen	77 K	245 ... 280 Ω
Liquid Helium	4.2 K	450 ... 520 Ω

Table 9.10: Characteristic Values of Carbon Composition Resistor

9.8 Magnet Technical Data

	Value	Unit
Proton frequency	800	MHz
Central field	18.8	T
Coil inductance	115.2	H
Magnetic energy	3472.2	kJ
Maximum drift rate [ppm/h]	0.01	ppm/h
Maximum drift rate [Hz/h]	8	Hz/h

Table 9.11: Magnet Specifications

Magnet System Operating Modes

- **Driven Mode**

In the driven mode the current lead is mounted and the current is led through the power supply. The coils of the magnet can be energized and deenergized.

- **Persistent Mode**

In the persistent mode the current flows exclusively within the magnet. The circuit has no connection to the outside. The magnetic field cannot be switched off.

9.9 Fringe Field Plot

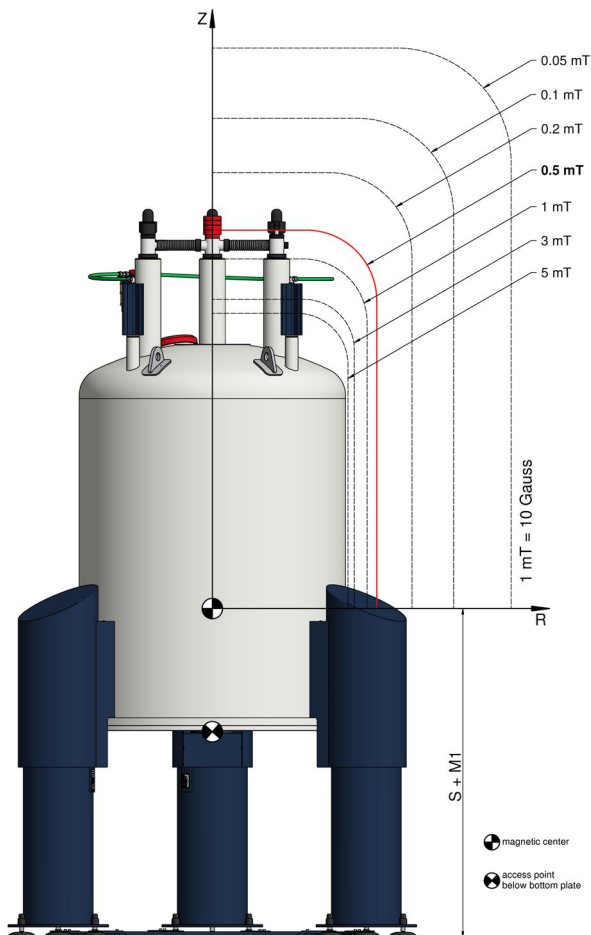

Figure 9.7: Fringe Field Plot of the Magnet System at Maximum Field

	Unit	R max	Unit	Z max	Unit
200	mT	46	cm	76	cm
5	mT	78	cm	150	cm
3	mT	85	cm	167	cm
1	mT	105	cm	212	cm
0.5 (5 Gauss)	mT	125	cm	250	cm
0.2	mT	169	cm	316	cm
0.1	mT	216	cm	381	cm
0.05	mT	282	cm	465	cm

Table 9.12: Fringe Field Data of the Magnet System at Maximum Field

Maximum magnetic field B0 at access point.	905.3	mT
Maximum field gradient dB/dz at access point.	8.97	T/m

Table 9.13: Maximum Magnetic and Gradient Field at Access Point

9.10 Filling Volume, Evaporation Rate and Hold Time

Cryogenic Agents Consumption during Installation

The consumption of liquid cryogenic agents during installation consists of consumption for cooling down the cryostat, for energizing, cryo shimming and quench reserve.

	Value	Unit
Nitrogen	800	l
Helium (needed for cool down)	900	l
Helium (needed for energizing, cryo-shimming and quench reserve)	500	l

Table 9.14: Cryogenic Agents Consumption during Installation

Cryogenic Agents Consumption during Operation

	Value	Unit
Nitrogen vessel total volume	218	l
Nitrogen refill volume	173	l
Nitrogen evaporation rate	400	ml/h
Nitrogen hold time	18	days
Helium vessel total volume	337	l
Helium refill volume	203	l
Helium evaporation rate	47	ml/h
Helium hold time	180	days
Helium refilling volume after quench (cool down and refill)	550	l

Table 9.15: Cryogenic Agents



Hold time is the maximum time interval between two fillings.

9.11 Nitrogen Level Graph

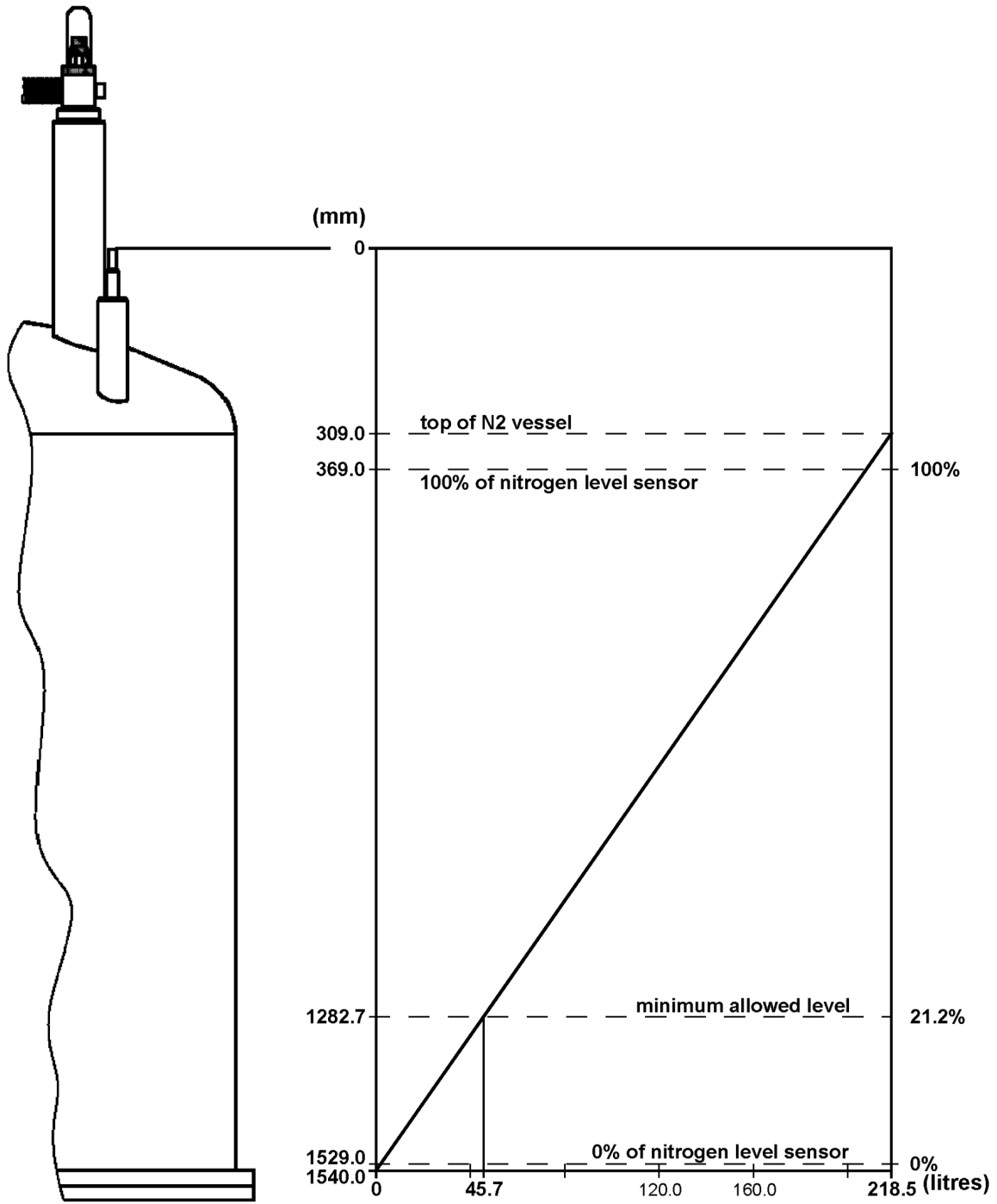

Figure 9.8: Nitrogen Level Graph (800'54 Design D)

9.12 Helium Level Graph

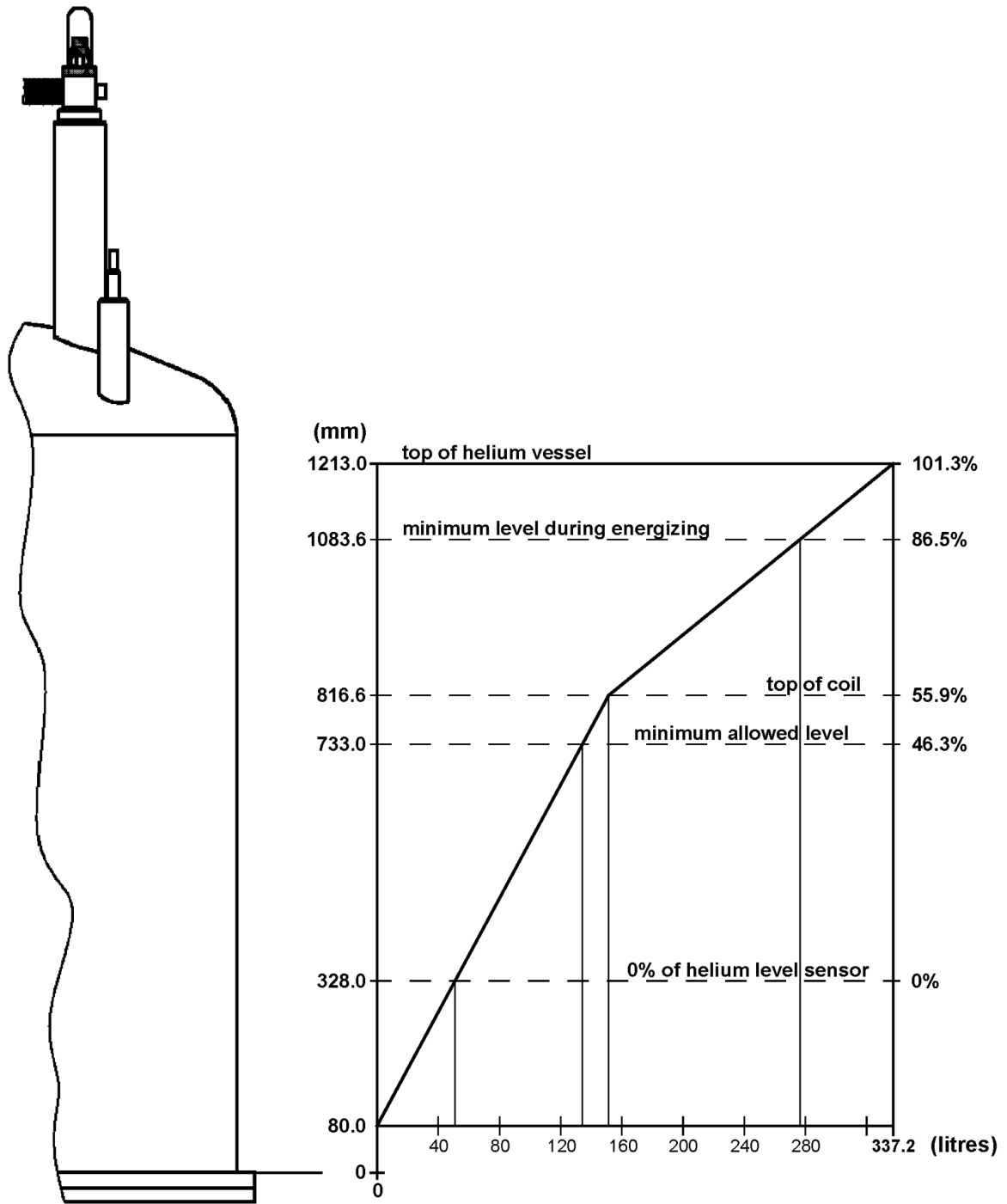

Figure 9.9: Helium Level Graph (800'54 Design D)

9.13 Resistance at Room Temperature

Current lead used to energize the magnet:

	High current lead and high current diagnostic lead, 55 pin, 300 A (blue)	
--	--	--

	Pin	Connector	Description	Value	Unit
From: To:	PIN V PIN S	19 PIN Con CONTROL 19 PIN Con CONTROL	Main Heater		Ω
From: To:	PIN D PIN S	19 PIN Con CONTROL 19 PIN Con CONTROL	Z Heater		Ω
From: To:	PIN G PIN S	19 PIN Con CONTROL 19 PIN Con CONTROL	X Heater		Ω
From: To:	PIN H PIN S	19 PIN Con CONTROL 19 PIN Con CONTROL	Y Heater		Ω
From: To:	PIN J PIN S	19 PIN Con CONTROL 19 PIN Con CONTROL	XZ Heater		Ω
From: To:	PIN K PIN S	19 PIN Con CONTROL 19 PIN Con CONTROL	YZ Heater		Ω
From: To:	PIN N PIN S	19 PIN Con CONTROL 19 PIN Con CONTROL	XY Heater		Ω
From: To:	PIN P PIN S	19 PIN Con CONTROL 19 PIN Con CONTROL	X ² -Y ² Heater		Ω
From: To:	PIN E PIN S	19 PIN Con CONTROL 19 PIN Con CONTROL	Z ² Heater		Ω
From: To:	PIN C,D,E,F PIN B,G,J,K	10 PIN Con SHIM 10 PIN Con SHIM	Shim Coils +/-		Ω
From: To:	PIN C,D,E,F PIN S	10 PIN Con SHIM 19 PIN Con CONTROL	Shim Coil + to Heater (common)		Ω
From: To:	+ PIN T	High current Con 19 PIN Con CONTROL	High Current + to Sense +		Ω
From: To:	+ -	High current Con High current Con	Main Coil		Ω
From: To:	- PIN U	High current Con 19 PIN Con CONTROL	High Current - to Sense -		Ω
From: To:	PIN F PIN S	19 PIN Con CONTROL 19 PIN Con CONTROL	Z ³ Heater		Ω
From: To:	PIN T PIN U	19 PIN Con CONTROL 19 PIN Con CONTROL	Sense + Sense -		Ω
From: To:	PIN C,D,E,F PIN T	10 PIN Con SHIM 19 PIN Con CONTROL	Shim Coil + to Sense +		Ω
From: To:	PIN T PIN S	19 PIN Con CONTROL 19 PIN Con CONTROL	Sense + to Heater (common)		Ω
From: To:	PIN K PIN H	10 PIN cool down Con 10 PIN cool down Con	Upper temperature sensor PT 100		Ω

	Pin	Connector	Description	Value	Unit
From: To:	PIN A PIN K	10 PIN cool down Con 10 PIN cool down Con	Carbon composition resistor		Ω
From: To:	PIN A PIN B	10 PIN cool down Con 10 PIN cool down Con	Lower temperature sensor PT 100		Ω
From: To:		All Connectors Ground	Insulation Magnet to Cryostat		Ω

Table 9.16: Resistance at Room Temperature

9.14 Heater Currents

	Value	Unit
Main heater current		mA
Shim heater current		mA

Table 9.17: Heater Currents

9.15 Shim Switch Heater

Heater operation during energizing / deenergizing.

Shim Switch	Heater Operation
Z ⁰	automatic
Z ¹	automatic
Z ²	permanent
Z ³	automatic
X	automatic
Y	automatic
XZ	automatic
YZ	automatic
XY	automatic
X ² - Y ²	automatic

Table 9.18: Shim Switch Heater Operation

9.16 Energizing Assignment and Currents

Check the “minimum level during energizing” (see [Helium Level Graph \[▶ 61\]](#)).

Energizing Currents [A]			Sense Voltage [mV]	Remarks Bruker Test Site
0	to	120.0	4000	
120.0	to	160.0	2000	
160.0	to	205.0	1000	
Pause overnight				
205.0	to	225.0	250	
225.0	to	232.0	100	
Pause overnight				
232.0	to	245.52	100	
Overshoot (0.2 % of final current)				
245.52 Final current	to	246.01 Overshoot	50	
10 minutes break at overshoot current				
246.01 Overshoot	to	245.52 Final current	50	
Total energizing time [min]				
778				
Rate of current ramp-down with magnet in persistent mode [A/min]				
20				
Mandatory wait time between energizing and shimming [h]				
42				

Table 9.19: Energizing Assignment and Currents

9.17 Magnetic Center

	Value	Unit
MCT: Distance magnetic center to top flange (calculated)	998	mm
MCB: Distance magnetic center to bottom flange (calculated)	512	mm
Shim System Offset (SO)		

Table 9.20: Magnetic Center

For shim system offset (SO) see the figure below and refer to the supplied Test Protocol AST.

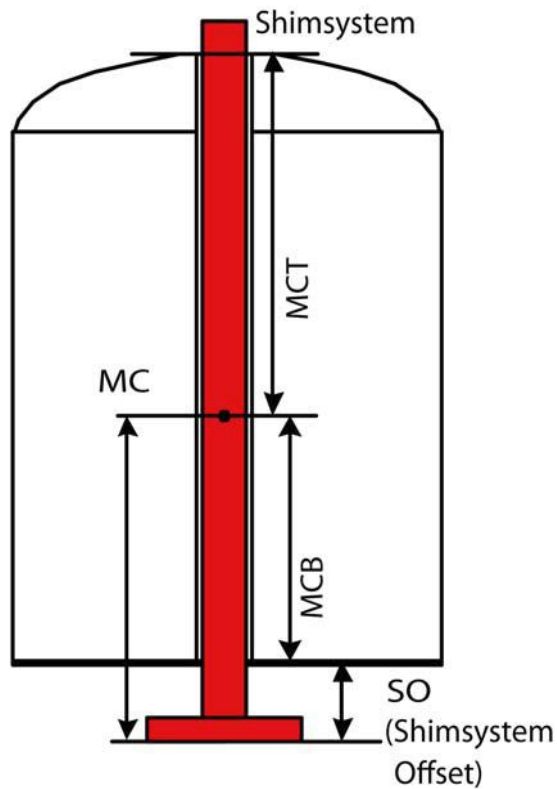

Figure 9.10: Magnetic Center and Shim System Offset (SO)

MC	Magnetic Center
MCT	Distance Magnetic Center to Top Flange
MCB	Distance Magnetic Center to Bottom Flange
SO	Shim System Offset

9.18 Cycling Assignment and Shim Currents

Cycling is recommended only for magnet systems at 500 MHz and more.

	Value	Unit
Shim current rate		A/min
Z ¹ shim current		A
Z ² shim current		A
Z ³ shim current		A
X shim current		A
Y shim current		A
XZ shim current		A
YZ shim current		A
XY shim current		A
X ² – Y ² shim current		A
Frequency change due to cycling		kHz
Date and Signature		

Table 9.21: Cycling Assignment and Shim Currents

9.19 Cryo Shim Currents

Magnet Main Current	Value at Customer Site #1	Value at Customer Site #2	Value at Customer Site #3	Value at Customer Site #4	Unit
Magnet main current					A
Magnet frequency					MHz

Table 9.22: Magnet Main Current

Cryo Shim Currents	Value at Customer Site #1	Value at Customer Site #2	Value at Customer Site #3	Value at Customer Site #4	Unit
Z ¹ shim current					A
Z ² shim current					A
Z ³ shim current					A
X shim current					A
Y shim current					A
XZ shim current					A
YZ shim current					A
XY shim current					A
X ² – Y ² shim current					A
Shim system offset design value	Refer to the supplied Test Protocol AST				mm
Shim system offset customer site value					mm
Date and Signature					

Table 9.23: Cryo Shim Currents

9.20 Deenergizing Assignment and Currents

Deenergizing Currents [A]			Sense Voltage [mV]	Remarks Bruker Test Site
245.52	to	225.0	200	
225.0	to	200.0	500	
200	to	0	1400	
Total deenergizing time [min]				
567				

Table 9.24: Deenergizing Assignment and Currents

This page is intentionally left blank.

9.21 Current Lead

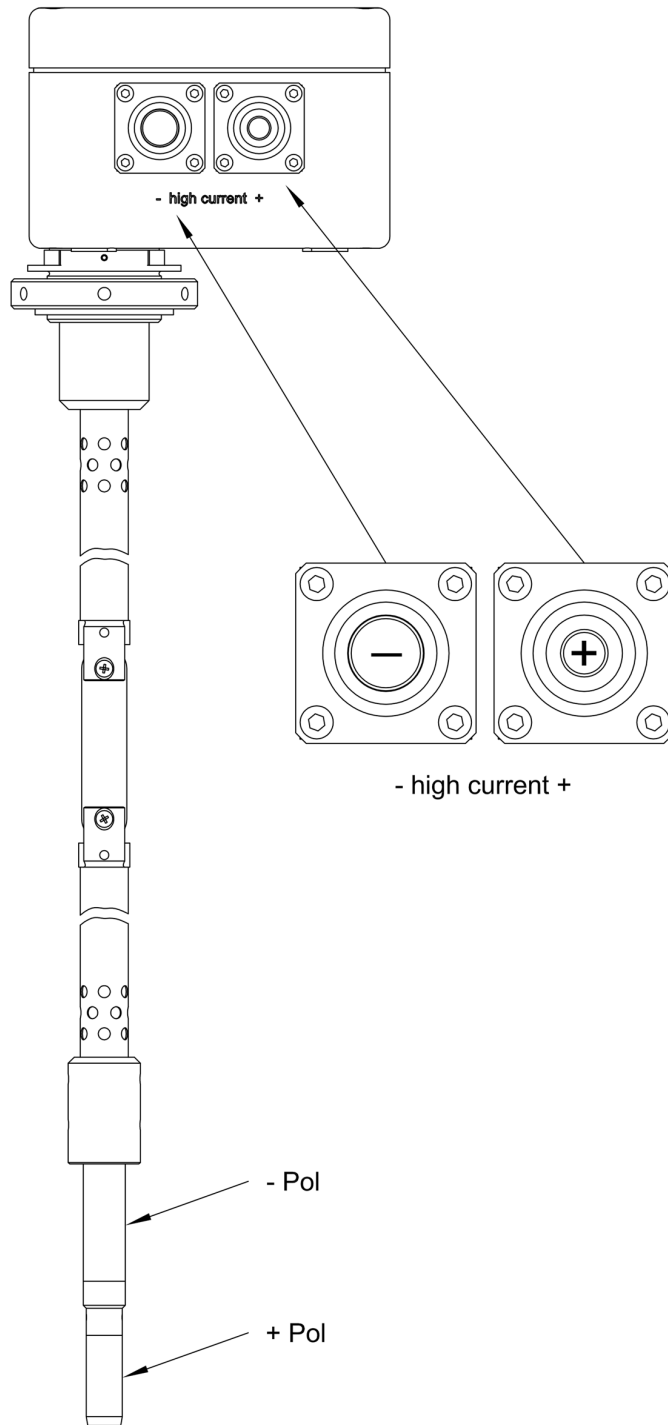

Figure 9.11: High Current Lead 2 Pin

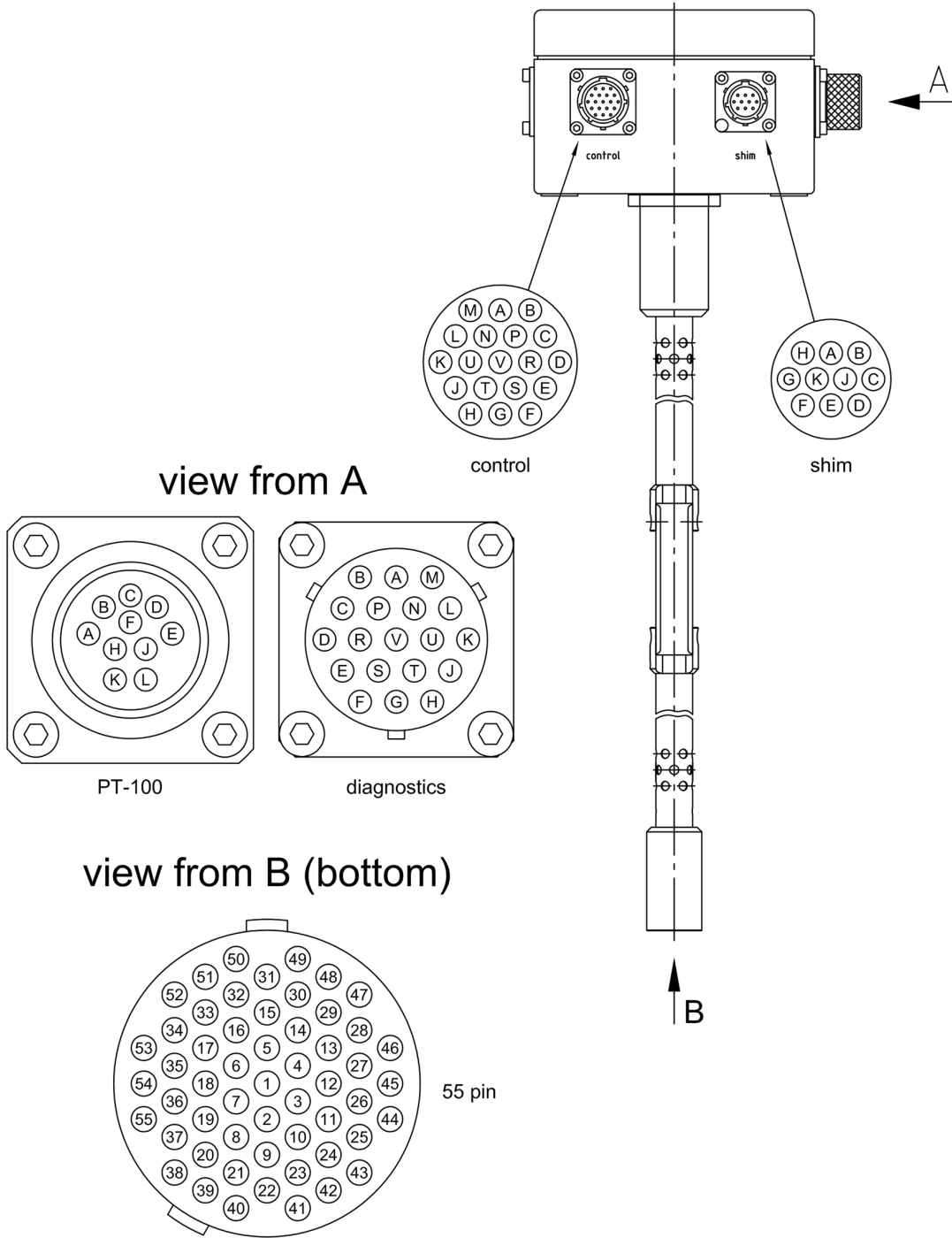
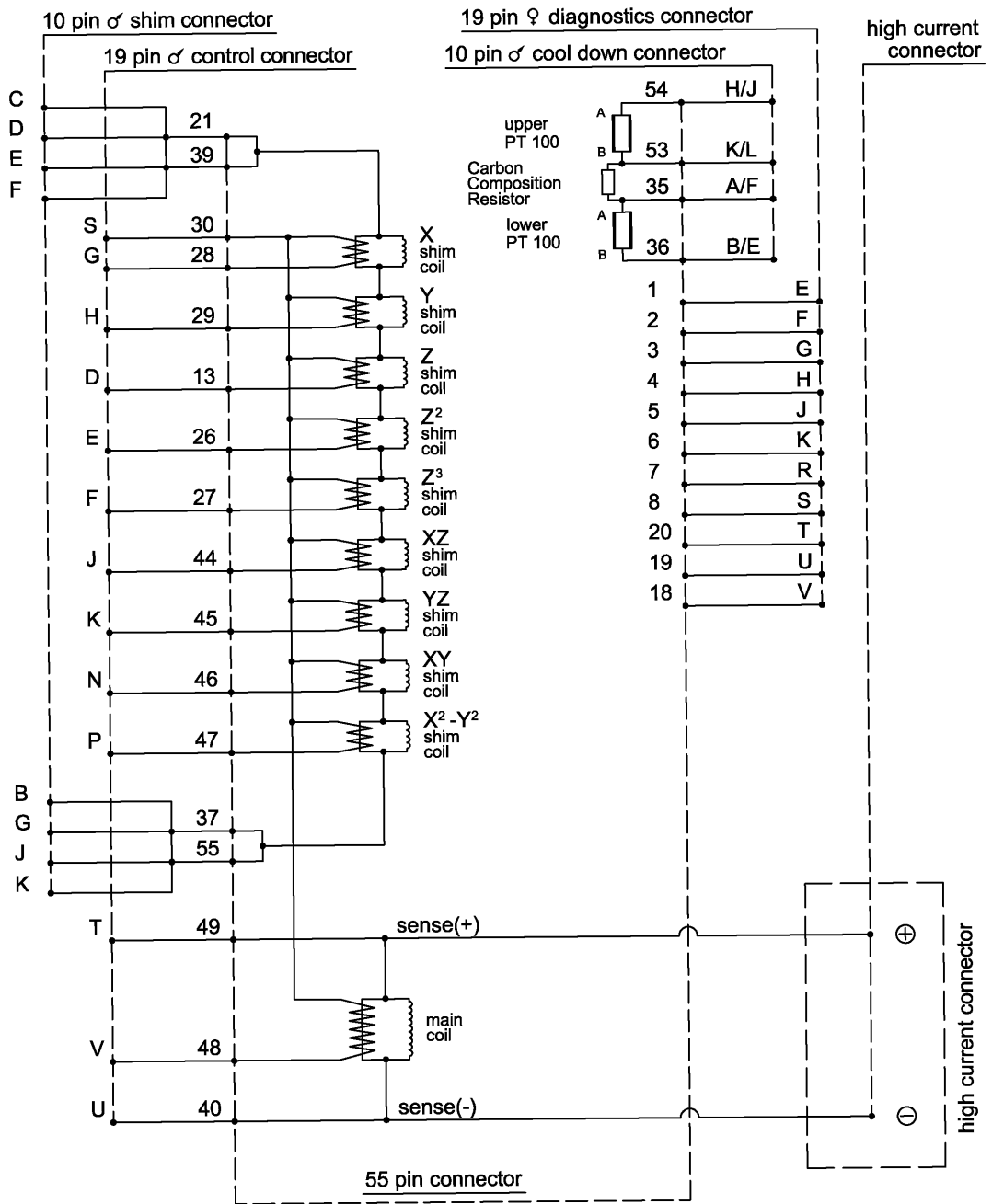

Figure 9.12: Diagnostic Lead 55 Pins

9.21.1 Wiring Diagram Magnet



Z1032992 D

Figure 9.13: Wiring Diagram Magnet

9.21.2 Wiring Diagram of Current Lead – Magnet Control and Shims

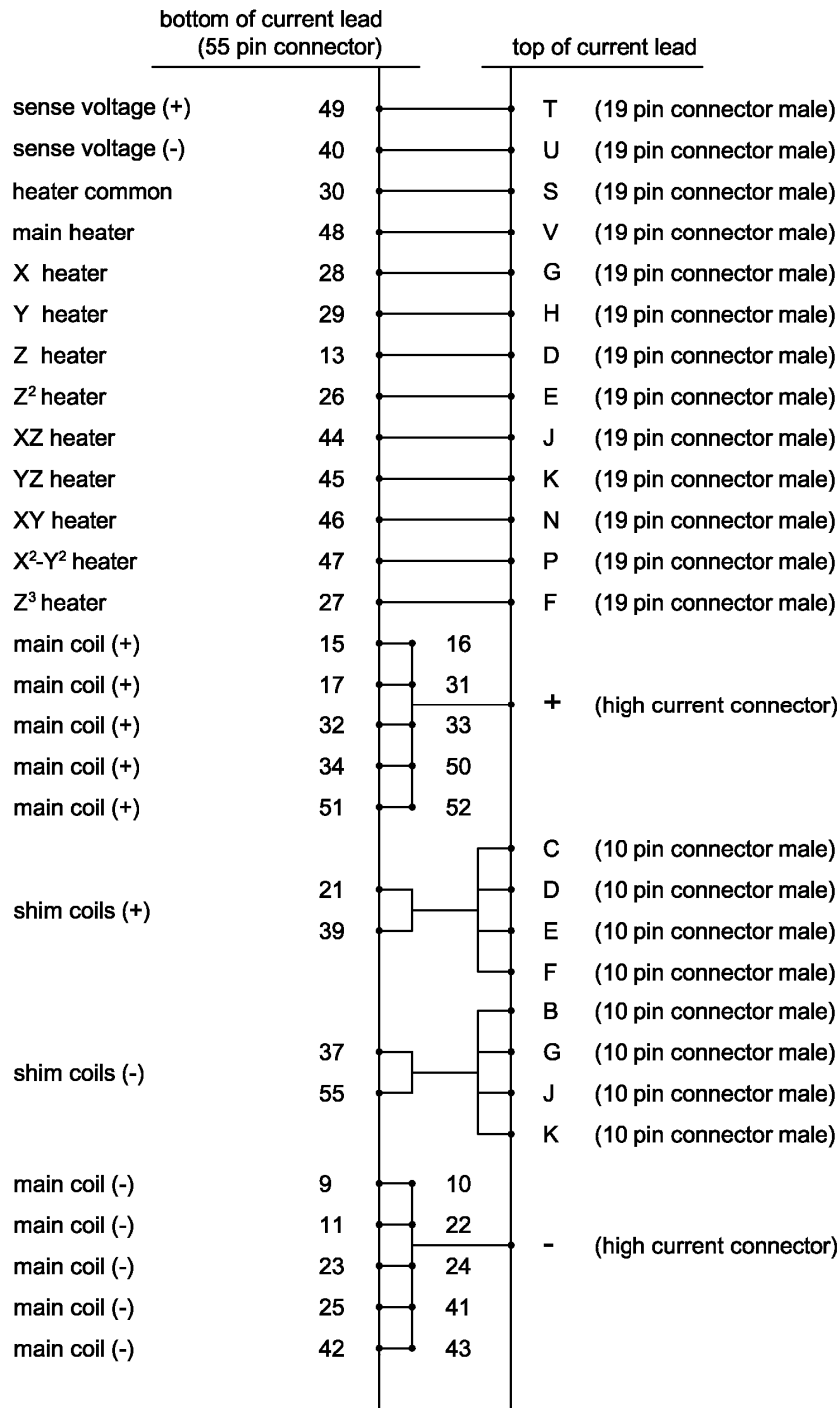

Z1029391

Figure 9.14: Wiring Diagram of Current Lead – Magnet Control and Shims

9.21.3 Wiring Diagram of Current Lead – Diagnostic and Temperature Sensors

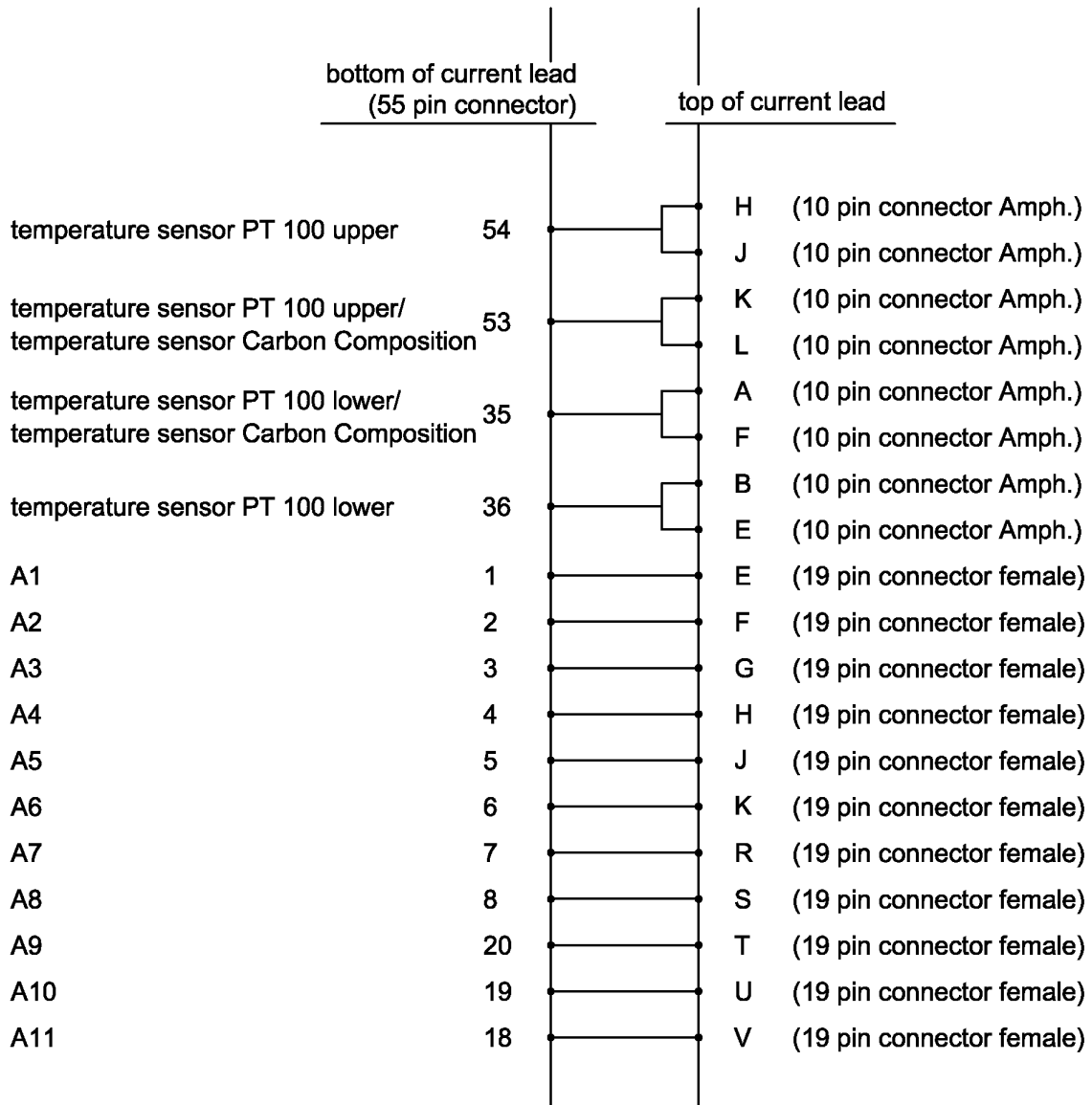

Z1029392

Figure 9.15: Wiring Diagram of Current Lead – Diagnostic and Temperature Sensors

9.21.4 Shorting Plug

The shorting plug is plugged after removal of the current lead. After inserting the shorting plug the current flows through the shorting plug and no longer through the current lead and the power supply.

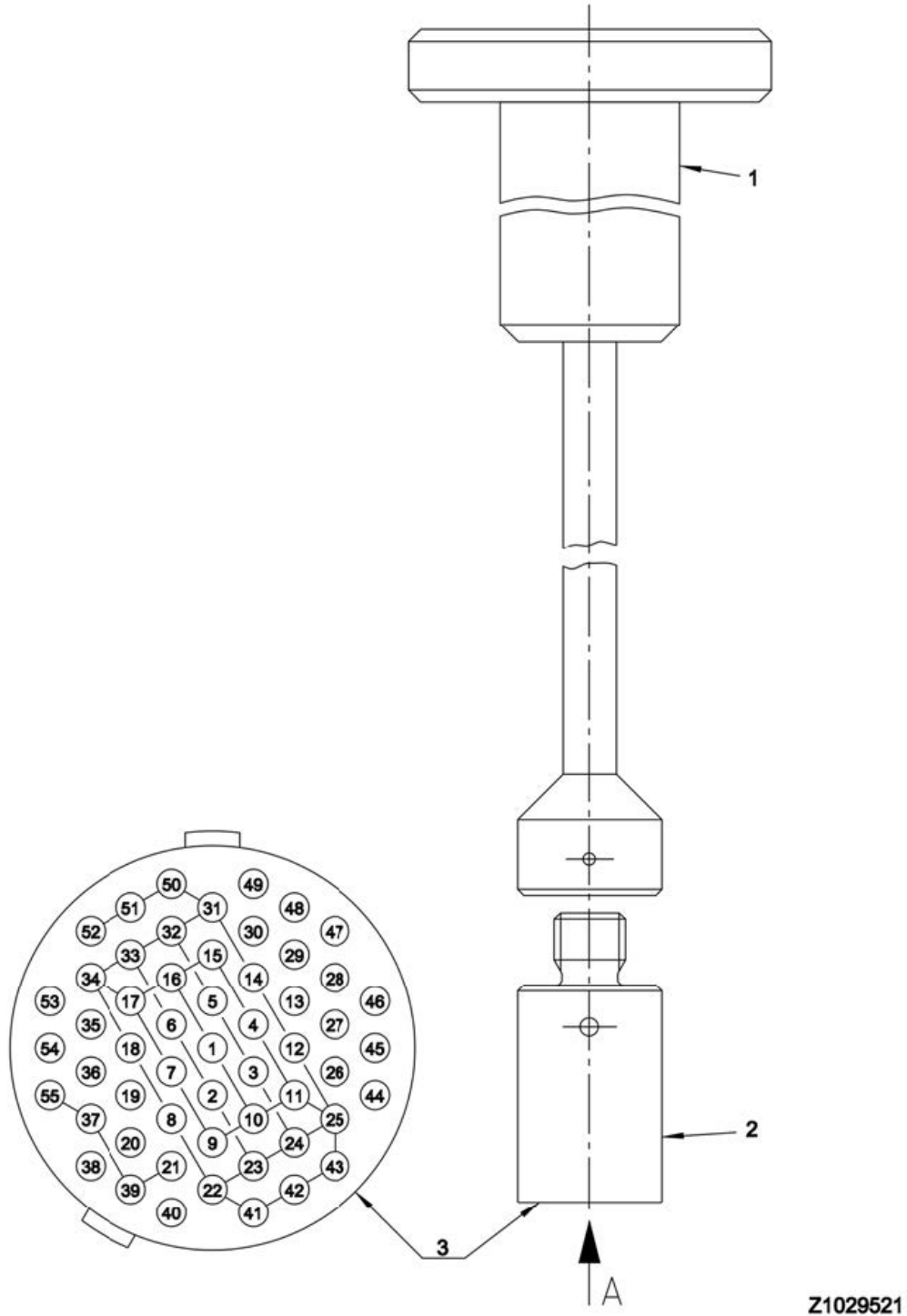

Figure 9.16: Shorting Plug 55 Pins

1	Shorting plug tool for fitting and removing the shorting plug
2	Shorting plug
3	Shorting plug – view from pin side

10 Contact

Manufacturer

Bruker BioSpin Group

Germany / France / Switzerland

Addresses and Contact via:

<https://www.bruker.com/service/information-communication/helpdesk.html>

E-Mail: nmr-support@bruker.com

Bruker BioSpin Hotlines

Contact our Bruker BioSpin service centers.

Bruker BioSpin provides dedicated hotlines and service centers, so that our specialists can respond as quickly as possible to all your service requests, applications questions, software or technical needs.

Please select the service center or hotline you wish to contact from our list available at:

<https://www.bruker.com/service/information-communication/helpdesk.html>

List of Figures

Figure 2.1:	Safety Devices of the Cryostat with 3 Helium Turrets	17
Figure 3.1:	Packaging (without surrounding panels).....	21
Figure 4.1:	General View of a Magnet System with 3 Helium Turrets	25
Figure 6.1:	Magnet system during a quench.....	40
Figure 9.1:	Dimensions of the Cryostat (front view).....	49
Figure 9.2:	Dimensions of the Cryostat (top view).....	51
Figure 9.3:	Safety Devices of the Cryostat with 3 Helium Turrets	52
Figure 9.4:	Nitrogen Level Sensor	53
Figure 9.5:	Helium Level Sensor.....	54
Figure 9.6:	Characteristic Curve of the PT 100 Sensor	55
Figure 9.7:	Fringe Field Plot of the Magnet System at Maximum Field	58
Figure 9.8:	Nitrogen Level Graph (800'54 Design D).....	60
Figure 9.9:	Helium Level Graph (800'54 Design D).....	61
Figure 9.10:	Magnetic Center and Shim System Offset (SO).....	65
Figure 9.11:	High Current Lead 2 Pin	69
Figure 9.12:	Diagnostic Lead 55 Pins	70
Figure 9.13:	Wiring Diagram Magnet	71
Figure 9.14:	Wiring Diagram of Current Lead – Magnet Control and Shims	72
Figure 9.15:	Wiring Diagram of Current Lead – Diagnostic and Temperature Sensors	73
Figure 9.16:	Shorting Plug 55 Pins	74

List of Tables

Table 5.1:	Start the Magnet Stand	27
Table 5.2:	Stop the Magnet Stand	27
Table 7.1:	Maintenance timetable.....	43
Table 7.2:	Maintenance-free components of the magnet system.....	44
Table 9.1:	Environmental Conditions	47
Table 9.2:	Weight.....	48
Table 9.3:	Dimensions for Transportation of the Magnet System.....	48
Table 9.4:	Dimensions of the Cryostat (front view).....	50
Table 9.5:	Dimensions of the Cryostat (top view).....	51
Table 9.6:	Opening Pressure of the Safety Valves of the Magnet System	52
Table 9.7:	Nitrogen Level Sensor	53
Table 9.8:	Helium Level Sensor.....	54
Table 9.9:	Characteristic Values of the PT 100 Sensor	55
Table 9.10:	Characteristic Values of Carbon Composition Resistor	56
Table 9.11:	Magnet Specifications.....	57
Table 9.12:	Fringe Field Data of the Magnet System at Maximum Field.....	58
Table 9.13:	Maximum Magnetic and Gradient Field at Access Point	58
Table 9.14:	Cryogenic Agents Consumption during Installation	59
Table 9.15:	Cryogenic Agents	59
Table 9.16:	Resistance at Room Temperature	62
Table 9.17:	Heater Currents	63
Table 9.18:	Shim Switch Heater Operation	63
Table 9.19:	Energizing Assignment and Currents	64
Table 9.20:	Magnetic Center	65
Table 9.21:	Cycling Assignment and Shim Currents	66
Table 9.22:	Magnet Main Current	67
Table 9.23:	Cryo Shim Currents	67
Table 9.24:	Deenergizing Assignment and Currents	67

Revision History

Revision	Date	Description of Change
00	September 2012	First release.
01	February 2013	Update magnetic center.
02	June 2013	New layout of title page and last page.
03	January 2018	Update of technical data; inserted shim system offset, shim switch heater operation and mandatory wait time after energizing. Magnet design D.
05	September 2021	User manual published in Schema ST4. Replaced Allen Bradley resistor by carbon composition resistor.

● **Bruker Corporation**

info@bruker.com
www.bruker.com

