

# Modular Compact Rheometer

MCR Series

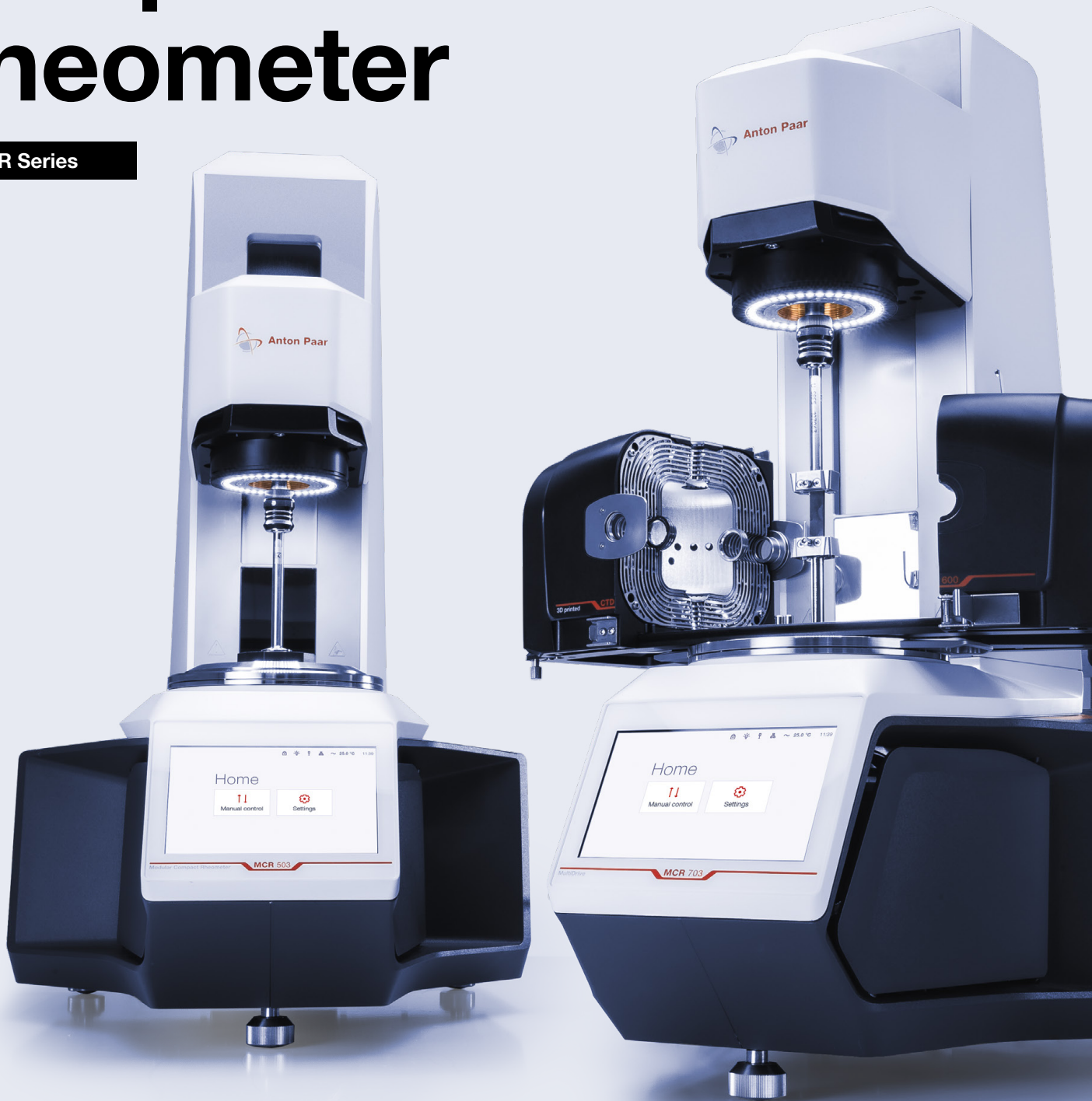

# A New Era in Rheometry

The new-generation MCR Series is a groundbreaking rheometer based on new modular platform architecture. The instrument delivers outstanding measurement quality to guarantee excellent reproducibility and remarkable productivity. Choose from the biggest portfolio on the market. We have an instrument for every need.

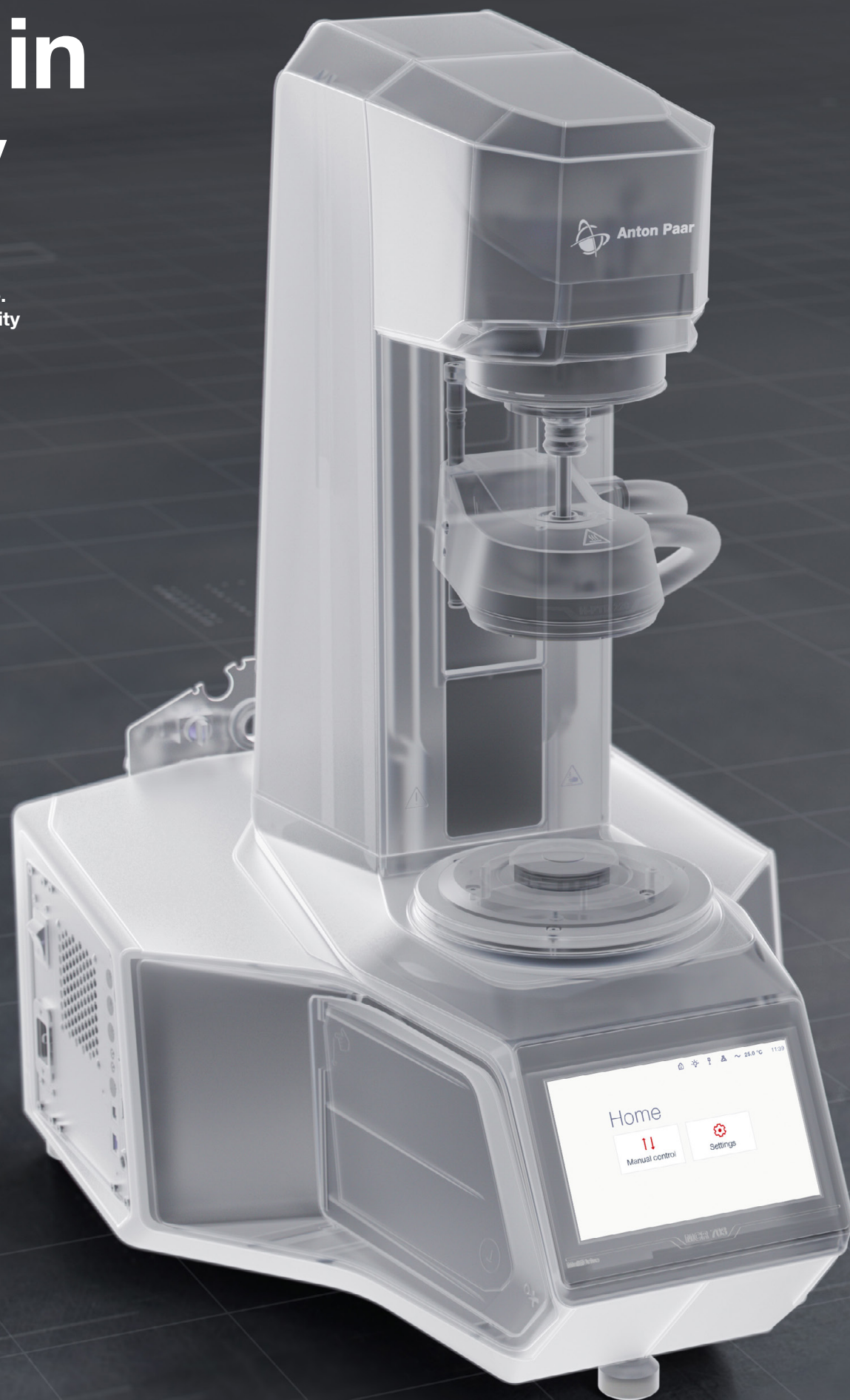

Torque range from 0.2 nNm to 300 mNm

Maximum frequency of rotational drive up to 200 Hz

Temperature control from -170 °C to +1,000 °C

250+ pre-defined test templates

15 devices and 200+ accessories

Ready for DMA, tribology, powder rheology, and mechanical testing

35+ subsidiaries for fast support, wherever you are

16,000+ installations worldwide

20+ years of technology leadership

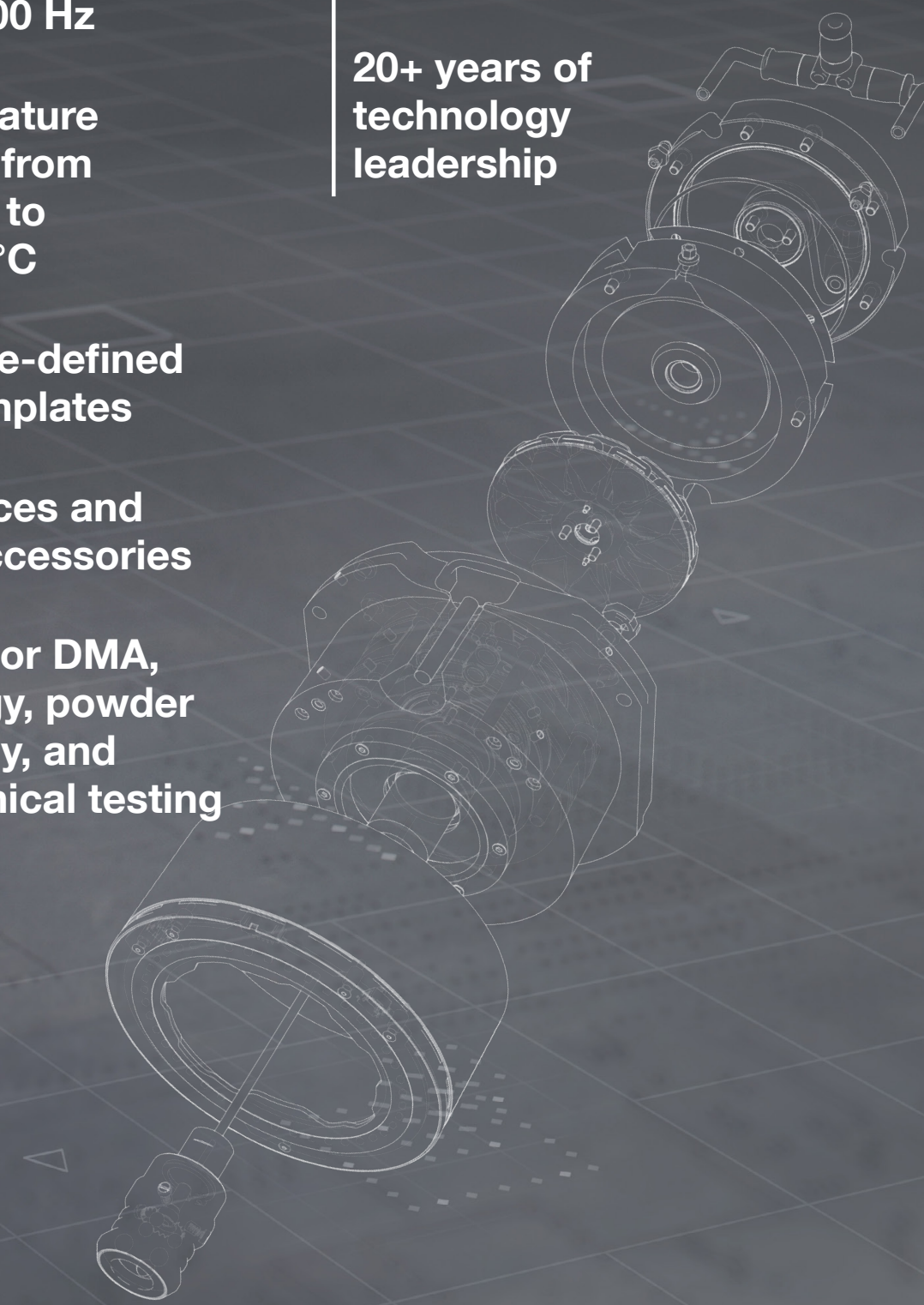

Find out more

# The Most Precise Rheometer

Step into a new era of rheometry with the most precise rheometer to date, offering improved measurement quality and insights unattainable by users of other instruments. This rheometer gives you new, previously unthinkable applications and makes every measurement better.

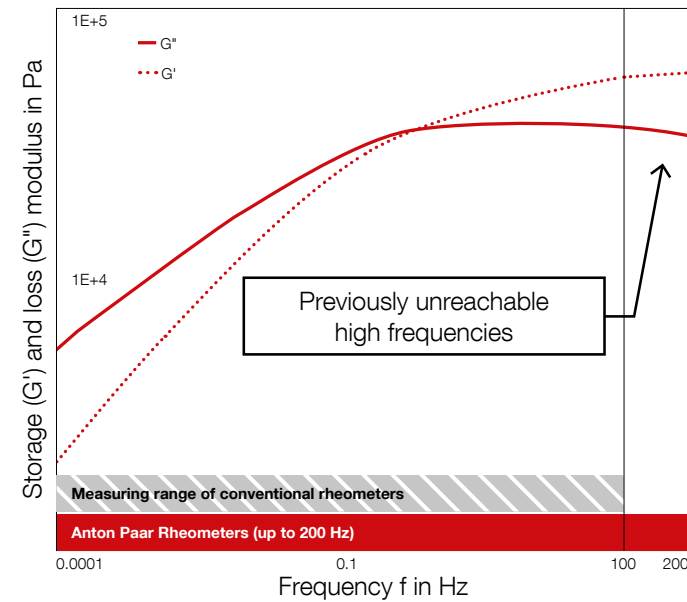

**Frequency: Up to 200 Hz**  
Extend your frequency range to 200 Hz and access more information than ever before within a reduced measuring time.

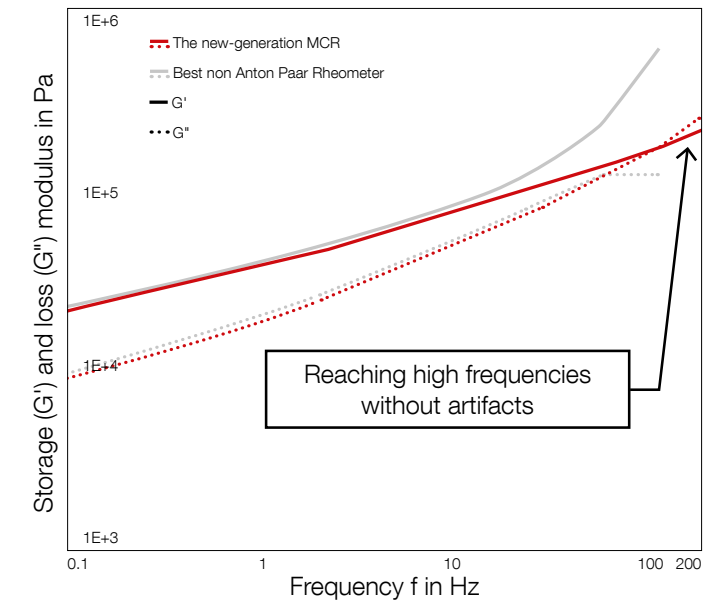

**Forget about inertia at high frequencies**  
Outstanding controllers – plus SMT mode with two EC motors – enable highest-frequency measurements, where others fail due to inertia. The crossover point of the pressure-sensitive adhesive measured above can only be captured with an MCR 703. No other rheometer in the world can achieve this.

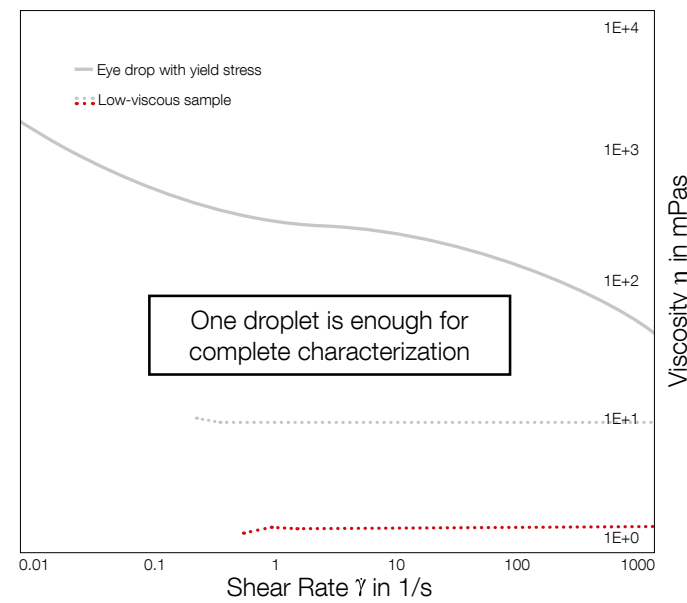
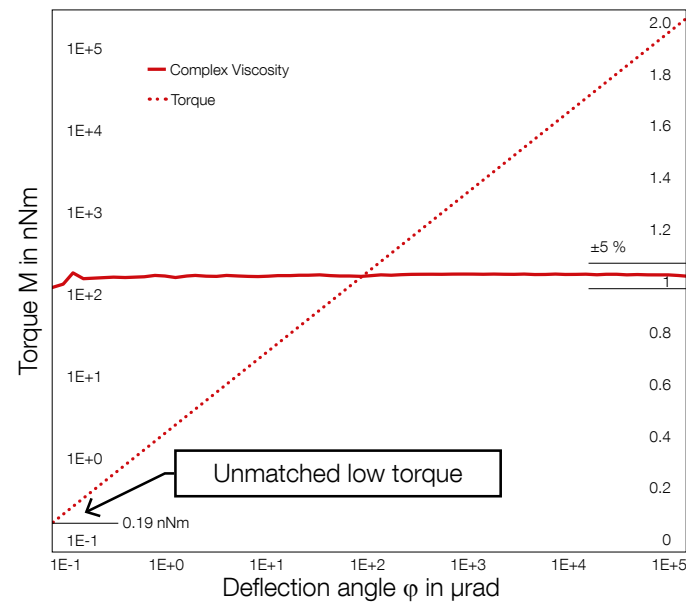

**Unmatched torque performance**  
The reimagined EC motor offers unique low torque sensitivity for precise measurements. Minimum torque of just 0.2 nNm in oscillation ensures exceptionally accurate results.

**Measure more precisely with less sample**  
Whether it's a precious low-viscosity protein or a single eye drop – just 70  $\mu$ l is enough for complete characterization. Reduce sample volume without compromising measurement range, even at low viscosities.

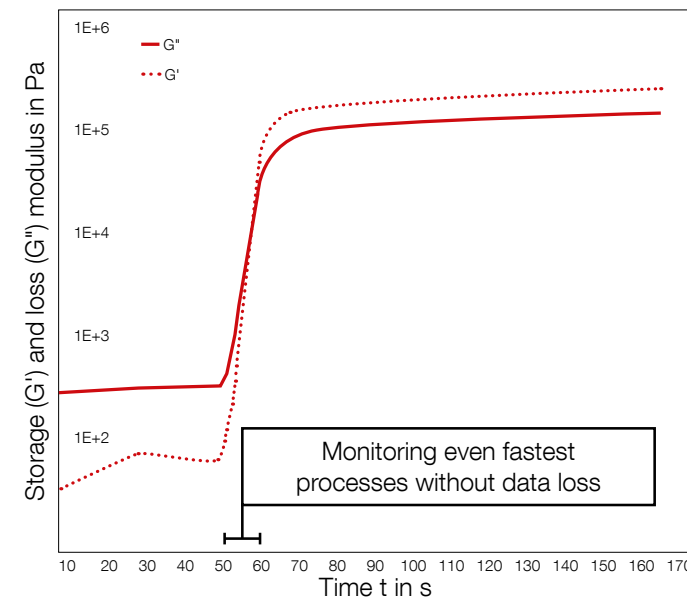

**New electronics for the fastest data acquisition**  
Monitor even the fastest curing processes without any data loss. Next-generation electronics and intelligent controllers (e.g., high dynamic gap control) result in the fastest data acquisition.

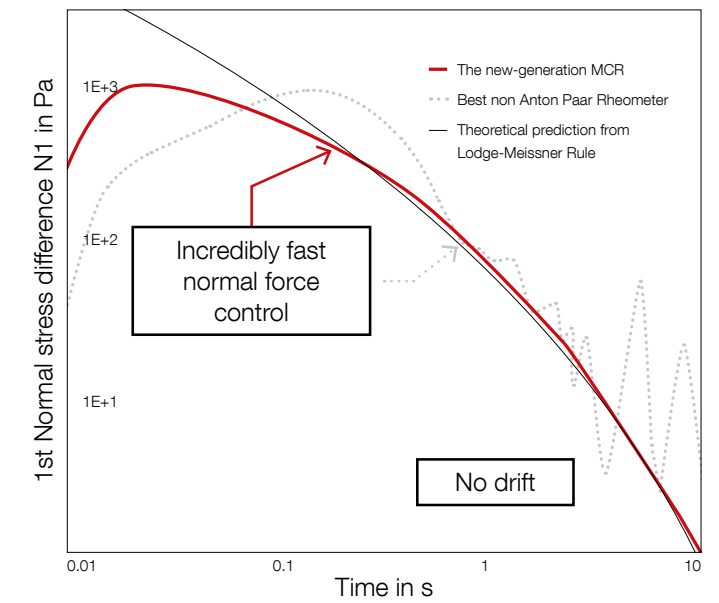

**New normal-force sensor**  
Avoid delayed transient normal force data, resulting in unmatched quality of normal stress difference measurements.

# The Smartest and Fastest Rheometer, from Start to Finish

## Pre-Measurement



### Electronic level

Eliminate inexplicable measurement errors due to lack of levelling. Quickly and straightforwardly, the electronic level of the MCR is saved in the measurement dataset, so you can fully trust your results.

### QuickConnect coupling

Couple your measuring geometry within seconds with just one hand.

### Toolmaster

Fully automatic recognition of measuring systems and accessories minimizes errors.

### Touchscreen operation

The integrated touchscreen has all the functions necessary to prepare a test directly from the rheometer.

### Temperature calibration

Our temperature calibration sets automatically calibrate the temperatures. They cover a range as wide as -160 °C up to +600 °C. The calibration data is saved, ensuring accurate results for all subsequent measurements.

### Trimming mirror and TruRay

The trimming mirror and TruRay illumination provide clear 360-degree visibility for sample trimming, optimizing measurement results and sample loading.

## Measurement

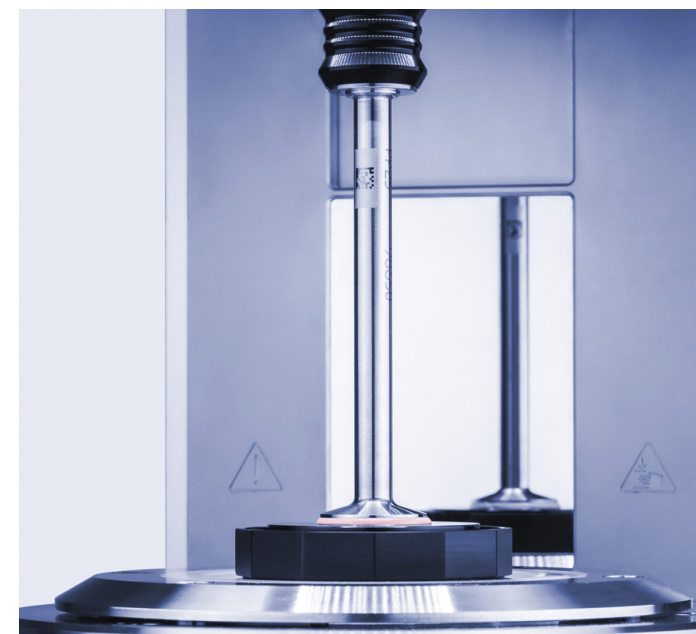

### Temperature equilibrium

There's no need to waste time ensuring temperature equilibrium. The MCR's automatic temperature equilibrium recognition gets you to accurate results quickly.

### Sample-adaptive controller

The sample-adaptive controller delivers high-quality results for unknown samples without time-consuming controller presetting.

### Automatic gap control

Temperature-related gap dimension change is compensated by using the automatic gap control (AGC) function to guarantee correct gap settings.

⊕ **Sustainability:** Save energy costs, and reduce your carbon footprint. In combination with the cost-efficient air Peltier temperature devices, the MCR saves up to 56 % more energy.

⊕ **Lab space:** All-in-one design preserves precious bench space.

⊕ **Quick boot time:** The MCR starts in just six seconds, over 7x faster than other devices.

## Post-Measurement

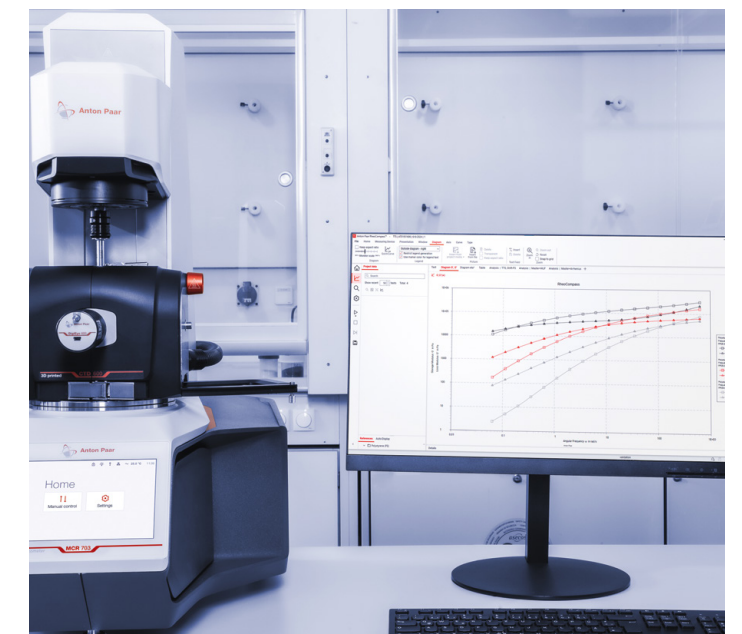

### RheoCompass software

The powerful RheoCompass software provides templates with ready-to-use reports as well as a report-customizing designer.

RheoCompass includes additional, improved analysis tools far beyond those of other rheometer software – resulting in deeper insights into your materials.

New analysis tools are frequently added to the software ensuring that you're always up-to-date.

# The Choice Is Yours

**Broadest portfolio on the market:** ViscoQC series and RheolabQC: Complete viscometer portfolio for entry-level applications | MCR 72 and MCR 92: Quick, straightforward rheological measurements | SmartPave rheometer: Designed for the asphalt industry | SmartMelt rheometer: Designed for polymer melt rheometry | MCR 503 Power: The most powerful rheometer model for special applications (with maximum torque of 300 mNm and normal force of 70 N) | FRS (furnace rheometer): Sample temperatures up to 1,730 °C | HTR automated rheometer: Operated by a robotic arm



## MCR 303

### Quick configuration

- Entry ticket into rheological product development and material formulation
- Torque range from 5 / 1<sup>1)</sup> nNm to 215 mNm
- Broad range of temperature-based accessories
- Productivity features such as Toolmaster, QuickConnect coupling, TruRay, and many more
- Replacement for the successful MCR 102e

## MCR 503

### Top-selling rheometer with entry-level DMA

- The top-selling rheometer for R&D and high-end QC testing
- Torque range from 0.2 nNm to 230 mNm
- Sample adaptive controller (TruStrain) included and DMA-ready
- 200+ plug-and-play accessories
- Solution for rheology, tribology, powder, entry-level DMA and mechanical testing
- Replacement for the top-seller MCR 302e

## MCR 703 MultiDrive

### A market-leading rheometer and DMA in one instrument

- Torque range from 0.2 nNm to 230 mNm empowering users to tackle the scientific challenges of tomorrow
- Upgrade with a second EC motor: Sophisticated working modes for in-depth rheometry – CMT, SMT, counter-movement (high shear), and superpositions
- Upgrade with a second linear drive: The most advanced dynamic mechanical analysis in all modes
- Advanced rheo-optical analysis

## MCR 703 Space MultiDrive

### Unique modularity, flexibility, and functionality

- Open instrument design for maximized working space and optimal access
- Torque range from 0.2 nNm to 230 mNm
- Expansion of MCR 703 MultiDrive functionalities
- Easy installation of 200+ accessories for research and development
- Straightforward combination with additional optical or mechanical setups, (e.g., a confocal microscope)
- Perfect choice for glovebox work, even in inert gas atmosphere (e.g., nitrogen, argon)

1) 1 nNm with activated TruStrain™ option

# MCR 703 MultiDrive: The Most Advanced Rheometer



The flagship MCR 703 MultiDrive is the most advanced platform for rheology and DMA. Designed for high-end R&D, the instrument is the reference for sophisticated material characterization.

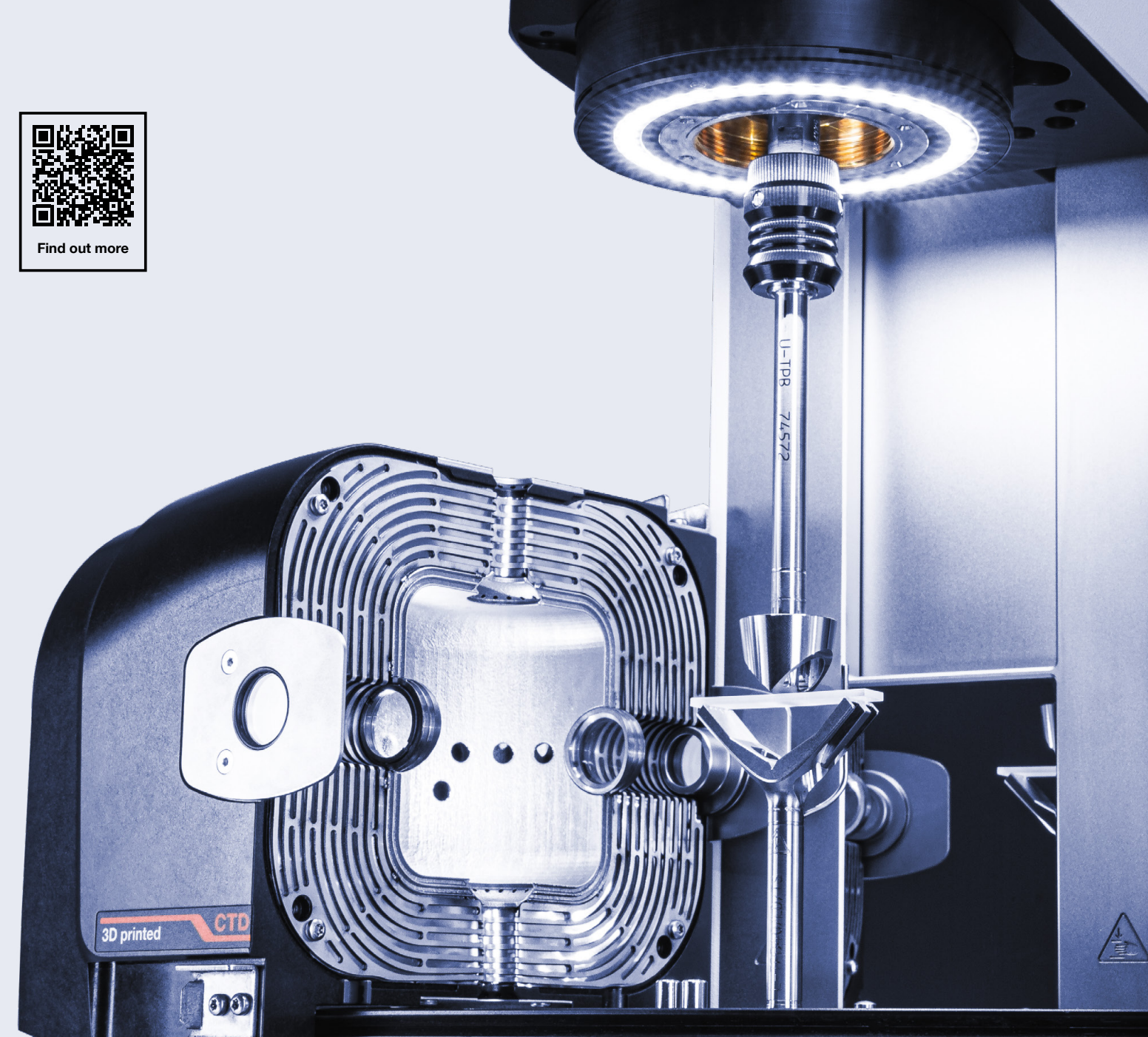

## One rheometer, all rheological working modes

- Unique setup: Work with one EC motor in combined motor transducer (CMT) mode, or two EC motors in separate motor transducer (SMT) mode
- SMT mode: One motor is operated solely as a torque transducer, while the other is used as a drive unit only – delivering the purest rheological results
- CMT mode: Use the motor's real-time position control (TruStrain), or perform "classic" stress-controlled tests in combination with the extensive range of accessories

## Expanding the limits of material characterization with counter-movement mode

- Two EC motors can rotate or oscillate in opposite directions
- Generation of fixed stagnation plane – helpful for advanced structure analysis of a sample with a microscope
- Extensional tests to previously unachieved elongation levels when combined with the universal extensional fixture
- Doubling of the maximum achievable rotational speed of the rheometer up to 6,000 rpm – helping broaden the shear rate range for high-shear applications

Patents: US Pat. 8453496 and US Pat. 9766172

## A revolutionary step for DMA

- Modular MCR concept allows easy integration of an additional lower linear drive for DMA in tension, bending, compression, creep and creep recovery tests, relaxation tests, and thermomechanical analysis
- Combined with the upper rotational drive for DMA in torsion, the setup enables complete characterization of viscoelastic solids with axial-torsional DMA – including determination of the Poisson's ratio and the direction-dependent characterization of anisotropic materials

Patents: US Pat. 9574983 and US Pat. 10908058

## Previously unthinkable applications

- The maximized workspace of MCR 703 Space MultiDrive allows easy installation of accessories and combination with additional external setups (e.g., a confocal microscope) suitable for advanced material characterization
- The rheometer's separate electronics box lets you set up the rheometer in a laboratory or in a laboratory glovebox, even when using inert gas atmosphere (e.g., for high-temperature measurements on samples with a certain hazard level)

# RheoCompass

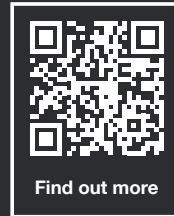

Find out more

The most powerful rheometer operating software for years.

RheoCompass is now accessible for everyone, with a new user interface and touchscreen for quick instrument operation. Be ready for any challenge, from routine QC testing to scientific applications.



## Accessible for everyone in everyday applications

**Quality control technician:** App manager with 250+ predefined templates | Touch control | Plausibility check of measurement parameters | Extended Toolmaster for automatic recognition and configuration | Automatic storage of measurements | Available in eight languages

**Lab managers:** Customizable measurement templates | Countless analysis methods for routine and advanced data analysis | Central database handling | Complete pharma package: Audit trail, electronic signature, and retrieval | Full compliance with QM regulations | Automatic data exchange with a LIMS

**Researchers:** Special packages and analyses for time-temperature superposition, calculation of molar mass distribution and relaxation-time spectrum, interfacial rheology, tribology, powder rheology, and SALS | Definition of even the most complex test methods | Camera control | Leveraging of raw data to record Lissajous figures, waveforms, and LAOS data



# We Have What You Need

Explore our portfolio of  
7,000+ measuring geometries  
and 200+ accessories. We also  
provide customized solutions.

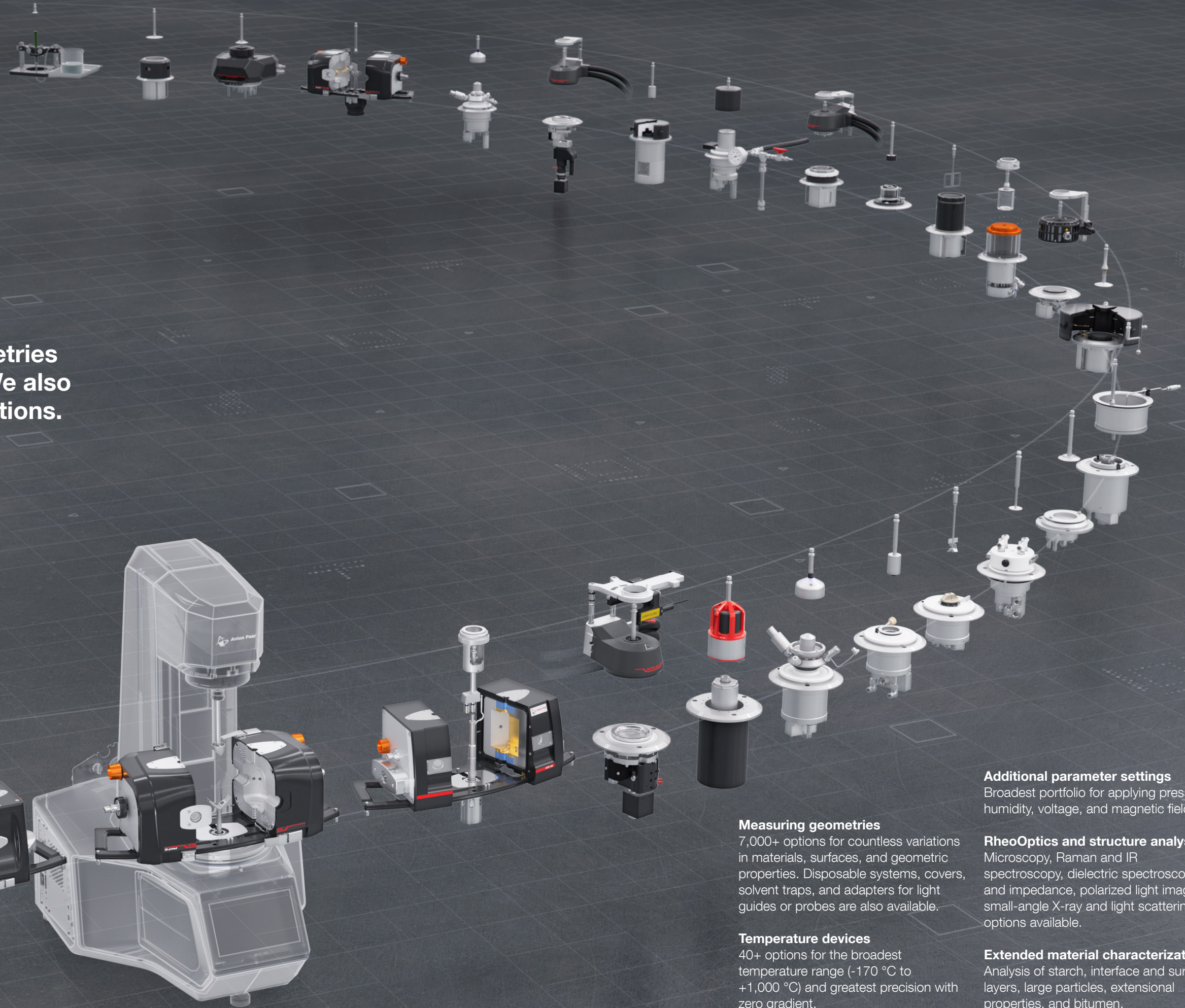

#### Measuring geometries

7,000+ options for countless variations in materials, surfaces, and geometric properties. Disposable systems, covers, solvent traps, and adapters for light guides or probes are also available.

#### Temperature devices

40+ options for the broadest temperature range (-170 °C to +1,000 °C) and greatest precision with zero gradient.

#### Additional parameter settings

Broadest portfolio for applying pressure, humidity, voltage, and magnetic fields.

#### RheoOptics and structure analysis

Microscopy, Raman and IR spectroscopy, dielectric spectroscopy and impedance, polarized light imaging, small-angle X-ray and light scattering options available.

#### Extended material characterization

Analysis of starch, interface and surface layers, large particles, extensional properties, and bitumen.

# The Broadest Temperature Range

**Additional temperature options:** Low-temperature options: Evaporation unit for cooling with liquid nitrogen down to **-170 °C** | Gas chiller options for cooling down to **-90 °C** without liquid nitrogen | Immersion: Cups to characterize samples while immersed in a temperature-controlled fluid | For extensional fixtures, plate-plate geometries, and DMA fixtures



Peltier temperature device



Electrical temperature device

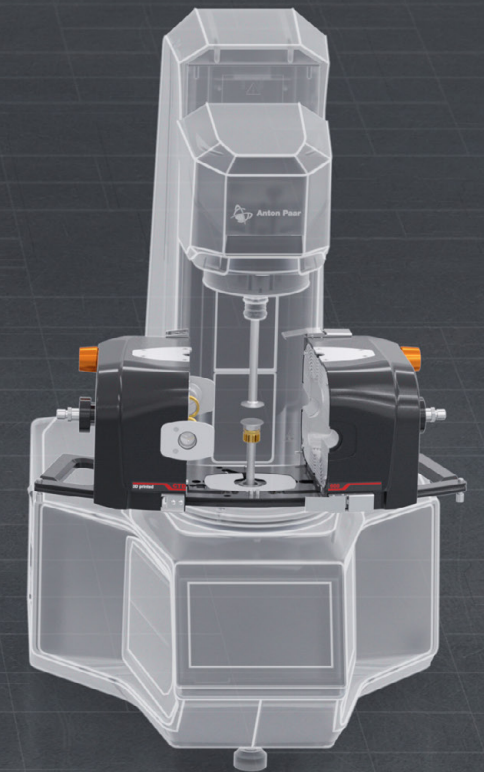

Convection temperature device

-170 °C

+1,000 °C

**40+ temperature devices control the greatest rheological influence of all. We offer the biggest range on the market, so you can measure at every temperature and with every application.**

#### **Peltier temperature device**

Compact and easily installable temperature devices based on heating and cooling using Peltier elements up to 220 °C:

- Unique temperature range from **-50 °C to +220 °C**
- Temperature devices combinable with plate-plate, cone-plate, concentric-cylinder, double-gap measuring geometries, and stirrers
- Active cooling without the need for additional low-temperature options
- Air-cooled Peltier systems available (no fluid circulator needed)

#### **Electrical temperature device**

Fast temperature devices based on electrical heating and cooling with pressurized air or fluid for temperature control:

- Temperature range from **-150 °C to +400 °C**
- Temperature devices combinable with plate-plate, cone-plate, concentric-cylinder, double-gap measuring geometries, and stirrers
- Additional heated hoods for minimized temperature gradients

#### **Convection temperature device**

The most flexible temperature devices based on forced convection of air or gas and radiation:

- Unique temperature range from **-170 °C to +1,000 °C**
- Temperature devices combinable with all measuring systems
- Gradient-free temperature control
- Integrated light and camera allowing real-time visualization of a sample
- Unique Peltier-based convection temperature device available to enable active cooling without the need for low-temperature accessories

# Additional Parameter Settings

Perform temperature-controlled rheological tests while applying an additional external parameter. Check how an additional parameter influences the behavior of your sample.

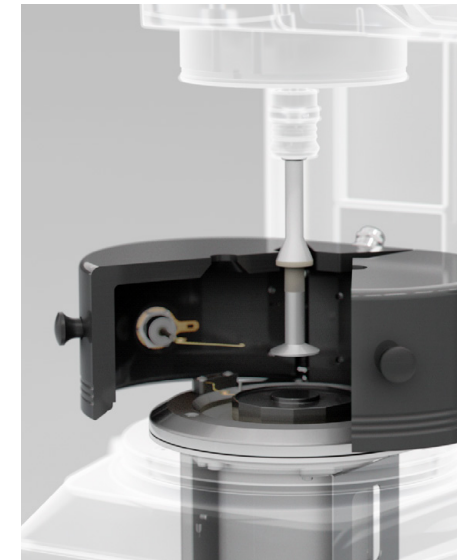

## Pressure cells

- Broadest portfolio on the market for applications in food, polymers, and petrochemicals
- Temperature range: -30 °C to +300 °C
- Pressure dependence of viscosity, simulation of extrusion and cooking conditions, avoidance of sample evaporation, influence of gases on viscosity (e.g., supercritical CO<sub>2</sub>)
- Up to 1,000 bar
- Gas-, liquid-, or self-pressurization can be used to control the pressure

## Humidity option

- Environmental system to control humidity and temperature – allowing the study of the influence of environmental conditions as well as drying kinetics
- Temperature range: 5 °C to 120 °C
- Humidity range: 5 % to 95 %
- Unique combinations with powder, tribology, DMA, extensional, and UV
- Standard- and custom-designed measuring systems can be used
- Patents: AT Pat. 513661 and DE Pat. 102015100714

## UV curing systems

- Study of kinetics during UV curing
- Temperature range: -40 °C to +300 °C
- Different mercury and LED light sources available, wavelength adoptable
- Usable with Peltier, electrical, and convection temperature devices
- Unique combinations with Raman or IR spectroscopy to simultaneously determine changes in the molecular level, and humidity option to control humidity

## Electro-rheological device (ERD)

- Characterization of electro-rheological fluids
- Temperature range: -40 °C to +200 °C
- Voltage range: 0 kV to 12.5 kV DC (AC on request)
- For plate-plate and concentric cylinder geometries
- Suitable for rotational, oscillatory, and squeeze flow

## Magneto-rheological device (MRD)

- Characterization of magneto-rheological fluids
- Temperature range: -40 °C to +170 °C
- Flux density: Max. 1.4 Tesla
- Patented TwinGap geometry (US Pat. 8132445) enables the highest homogeneous magnetic fields and higher shear rate measurements

## Immobilization cell (IMC)

- Investigation of immobilization kinetics, water retention, and drying by simulating process conditions
- Vacuum generated by a pump forces the liquid phase of the sample to penetrate into the base paper so the moisture is extracted from the coating

## Applications

Crude oil  
Food  
Petrochemicals  
Polymers

Adhesives  
Coatings and paints  
Food  
Pharmaceuticals  
Polymers  
Sealants

Adhesives  
Coatings  
Dental composites  
Epoxy resins  
Glues  
Printing inks

## Applications

Clutches and brakes  
Dampers  
Food  
Haptic devices  
Printing inks  
Pumps  
Shock absorbers

Brakes  
Clutches  
Human prosthesis  
Sealings  
Seismic dampers  
Shock absorbers

Paints  
Paper coatings  
Slurries

# RheoOptics and Structure Analysis

The combination of rheometry and structural analysis provides both the macroscopic big picture and simultaneous insight into the smallest microstructural changes.

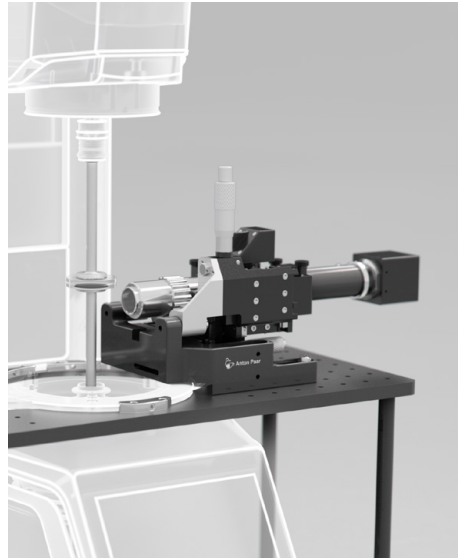

## Rheo-microscopy

- Insight into the structure of the sample during shearing
- Temperature range: -20 °C to +300 °C
- Variants for configurations with one EC and two EC motors (view at stagnation plane) available
- Modules for polarizers and fluorescence
- Direct assignment of images and videos to rheological data



## Rheo-Raman and IR spectroscopy

- Combination of two powerful measurement principles: Rheology for mechanical properties and Raman or infrared spectroscopy for molecular analysis
- Temperature range: -20 °C to +300 °C
- Unique combination with UV curing possible
- Can be combined with Anton Paar's Cora and other spectrometers
- Usable near-IR (NIR) and mid-IR (MIR) as well as attenuated total reflection mode (ATR)



## Dielectric spectroscopy and impedance

- Dielectric spectrum providing information on the internal structure
- Temperature range: -160 °C to +600 °C
- Electrolyte contact-free, or spring, wire-shaft contact
- Various LCR meters can be combined
- Permittivity and impedance analysis



## Polarized light imaging

- Visualization of shear stress
- Temperature range: -20 °C to +300 °C
- Parallel-plate and cone-plate measuring geometries
- Illuminated sample diameter: 25 mm
- Movable polarizer for selecting parallel or orthogonal polarization
- Customized setup based on high speed polarization camera for high resolution shear stress visualization and quantitative analyzes of birefringence (Rheo-Iris)



## Particle imaging velocimetry (PIV)

- Visualization of complex flow fields such as shear banding, turbulences, or flow instabilities
- Temperature range: 10 °C to 70 °C
- Variants for configurations with one EC motor (Searle mode) and two EC motors (Searle, Couette, and counter-movement modes)



## Further accessories

- Small-angle light scattering (SALS):
- Investigation of shear-dependent shape and orientation of microstructure
  - Temperature range: -20 °C to +300 °C
  - Wide scattering angle allowing measurements in large size range
- Small-angle X-ray/neutron scattering (SAXS/WAXS/SANS):
- Nanostructure analysis
  - Modular, radiolucent convection oven from -50 °C to +300 °C

## Applications

Biological fluids  
Cosmetics  
Crystallization  
Emulsion droplets and capsules  
Food

Biological samples  
Chemical reactions  
Crystallization  
Morphology of polymers

Battery slurries and inks  
Cellulose  
Crystallization  
Liquid crystals  
Polymers  
Surfactants

## Applications

Adhesives  
Biomaterials  
Cosmetics  
Paints  
Polymers

Biological fluids  
Colloids  
Surfactant solution

Biomaterials  
Colloids  
Cosmetics  
Crystallization  
Food  
Polymers  
Surfactants  
Suspensions

# Extended Material Characterization

From starch behavior and interfacial rheology to particle flow and building materials, these advanced systems provide valuable insights for research, development, and quality control.

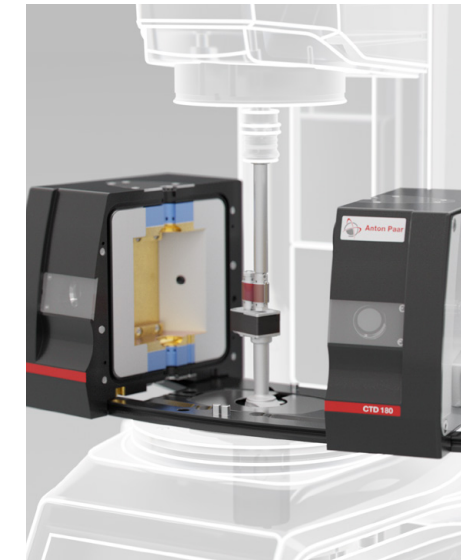
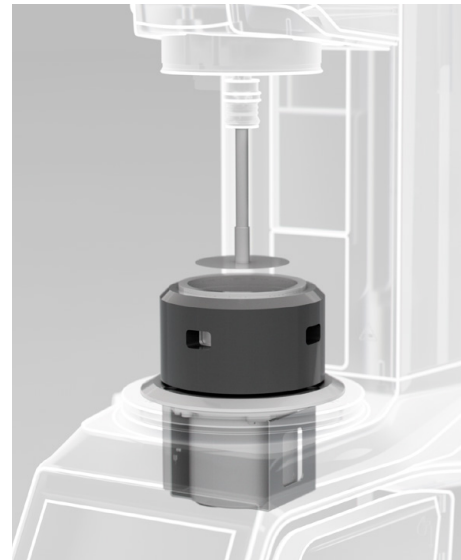
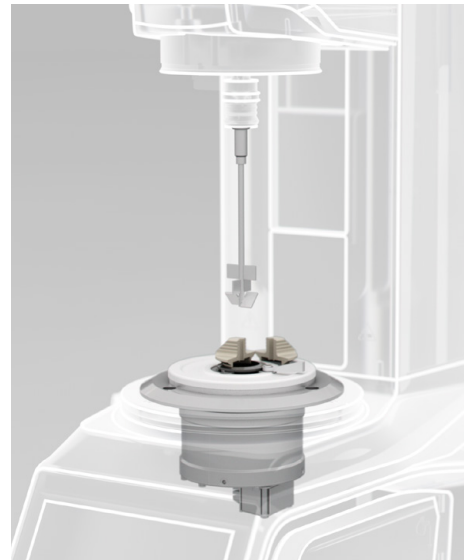

## Starch cell

- Analysis of starch pasting behaviour and functionality of proteins
- Simulation of temperature and pressure condition of food production process
- Max. heating rate: 60 °C/min
- Max. cooling rate: 45 °C/min
- Optional starch pressure cell up to 30 bar and 160 °C

## Interfacial rheology system (IRS)

- Rheological measurements of interface and surface layers
- Temperature range: 5 °C to 70 °C
- Measurement of even the weakest interfacial structures using the MCR low-torque capabilities and TruStrain feature
- Bi-cone and ring measurement systems
- Flow-through option available on request

## Ball measuring system (BMS)

- Measurement of the flow properties of samples with large particles (1 mm to 10 mm)
- Temperature range: -10 °C to +70 °C
- Measuring principle: Eccentrically rotating ball-in-a-cup to avoid undesired slipping, gliding, and disturbing edges

## Building material cell (BMC)

- Measurement of the flow properties of samples with large particles (1 mm to 10 mm)
- Temperature range: 0 °C to 90 °C
- Changeable, robust, and easy-to-clean cage and special stirrer
- Resistance to abrasive materials prevents sample slippage and provides improved mix-up effects to avoid separation

## Extensional rheology

- Determination of extensional properties and information about molecular structure, branching, shrinkage, relaxations, and adhesion
- Universal extensional fixtures (UXF), patented UXF/TD (US Pat. 9766172) and Sentmanat Extensional Rheometer (SER) enabling film and fiber testing up to 350 °C
- Customized capillary extension system enabling characterization of complex fluids based on capillary breakup measurements

## Bitumen rheology

- Specialized SmartPave Dynamic Shear Rheometers (DSR) for all applications, from daily routine tests to research tasks in the asphalt industry
- Compliant with a large number of standards (e.g., AASHTO, ASTM, EN, FGSV, IS, and AGPT)
- RheoCompass software includes standard operation procedures for a wide range of methods
- Temperature calibration procedure in combination with Peltier temperature control systems guarantees accurate results

## Applications

Dairy products  
Flour  
Malt  
Proteins  
Starch

Detergents  
Encapsulation  
Eye drops  
Food  
Pharmaceutical and cosmetics

Food  
Slurries  
Suspensions

## Applications

Cement  
Concrete  
Plaster  
Sludges

Adhesives  
Coatings  
Inks  
Melts and solutions  
Polymer films

Asphalt additives  
Asphalt binder  
Bitumen  
Bitumen emulsions  
Mastics  
Roofing shingles

# More Than Just a Rheometer

Our MCR devices aren't just rheometers. They're characterization super-machines. They make tribological and powder characterization, dynamic mechanical analysis, and conventional mechanical testing possible.

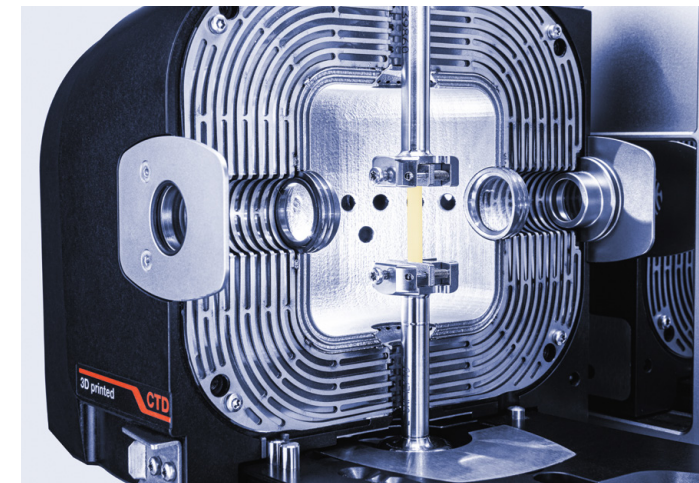
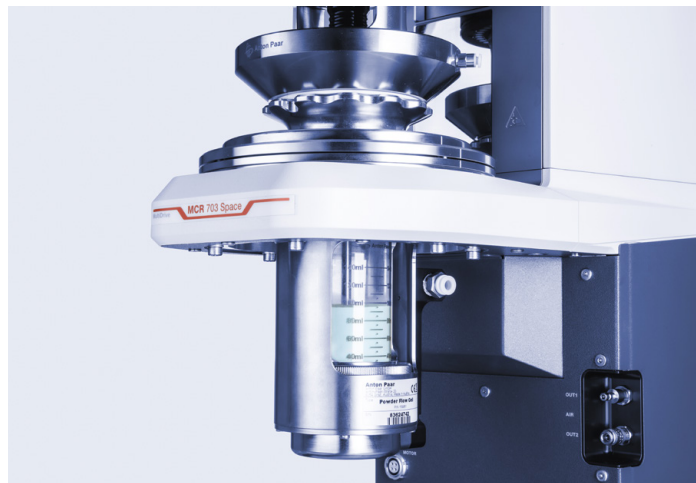
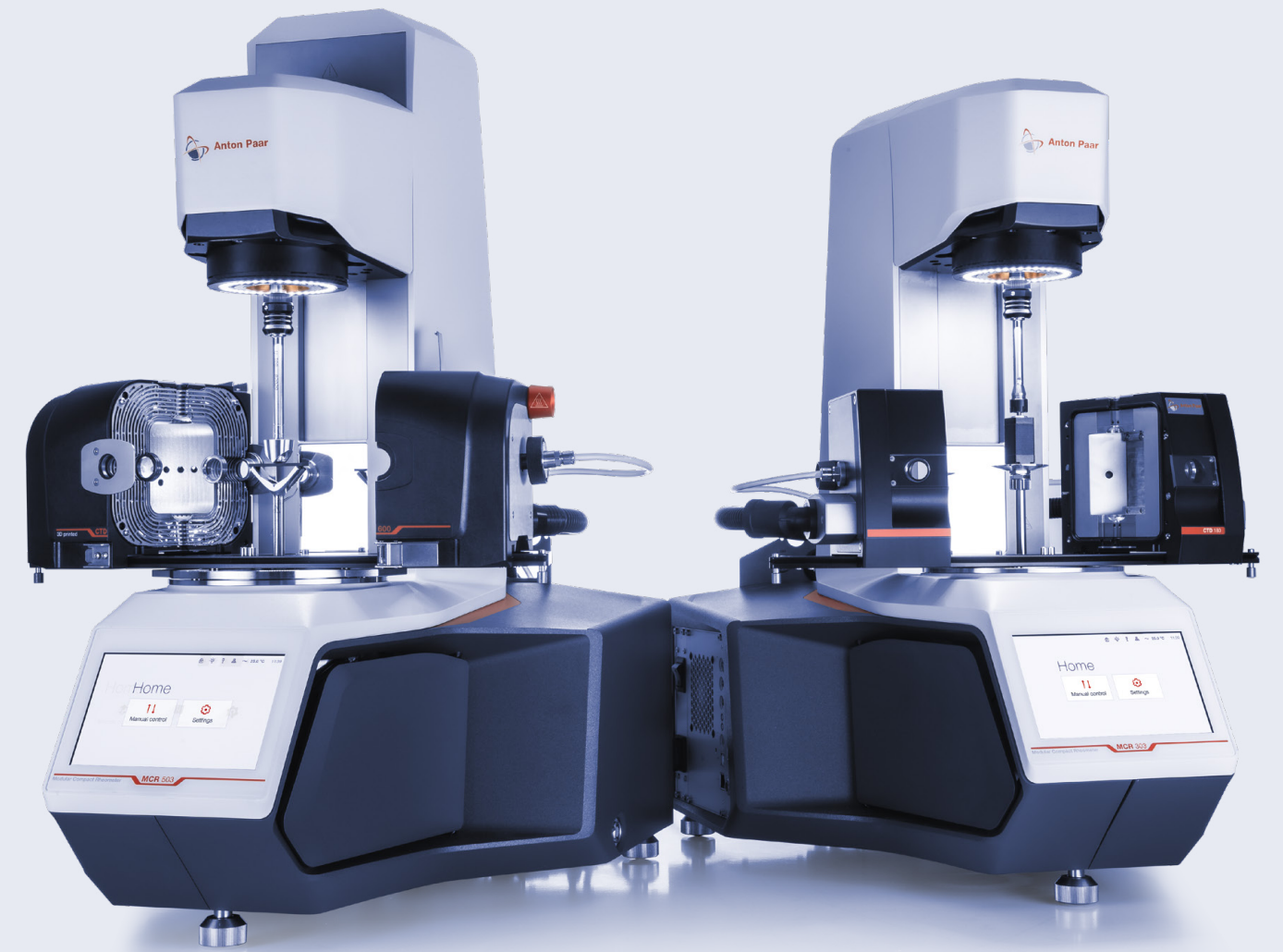

## Powder testing

An MCR rheometer combined with the powder shear cell and powder flow cell enables comprehensive powder characterization. These unique cells ensure highly sensitive determination of powder behavior and deliver reliable results that can be applied throughout your entire process chain.

Patent: US Pat. 10031057

## MCR tribometer

Employ the precise motion and normal force control of MCR tribometers for your tribological measurements. Expand your traditional tribological tests by opening up entirely new measuring ranges on a single instrument. Seamlessly measure breakaway forces or plot Stribeck curves over nine decades of sliding speeds.

Patent: US Pat. 9702809

## Dynamical mechanical analysis (DMA)

The MCR series enables precise determination of a material's modulus, stiffness, and damping behavior, as well as creep and relaxation of viscoelastic solids. It also provides crucial insights into glass or transition regions, the influence of fillers, additives, water, and plasticizers, as well as compatibility, curing, and aging. DMA can be performed in tension, torsion, bending, compression, and even in combined axial-torsional modes.

## Mechanical testing

Leverage the sensitivity and precision of our MCR technology for testing parts, components, or texture. The UTM Micro opens up a whole new world of low-force syringe testing and low-torque universal material testing. We all know traditional tack tests. Now you can also perform texture analysis; peel, puncture, and friction testing; flexure, torsion, tensile, and compression testing; as well as much more.

	MCR 303	MCR 503	MCR 503 Power	MCR 703 MultiDrive / MCR 703 Space MultiDrive Configuration with one EC motor	MCR 703 MultiDrive / MCR 703 Space MultiDrive Configuration with two EC motors
<b>Bearing design</b>	Air, fine-pored carbon				
<b>Motor design</b>	Electronically Commutated (EC) Permanent Magnet Synchronous Motor				
<b>Displacement transducer</b>	High-resolution optical encoder				
<b>Normal Force measurement design</b>	360° capacitive sensor, non-contacting, fully integrated in bearing				
<b>Working modes</b>	CMT			CMT, SMT, Counter-Movement <sup>1)</sup>	
<b>Min. torque (rotation)</b>	5 nNm	1 nNm	100 nNm	1 nNm	
<b>Min. torque (oscillation)</b>	5 / 1 <sup>2)</sup> nNm	0.2 nNm	50 nNm	0.2 nNm	
<b>Max. torque</b>	215 mNm	230 mNm	300 mNm	230 mNm	
<b>Torque resolution</b>	0.1 nNm	0.05 nNm	0.2 nNm	0.05 nNm	
<b>Angular deflection resolution</b>	3 nrad	<1 nrad			
<b>Min. angular velocity<sup>3)</sup></b>	0 rad/s				
<b>Max. angular velocity / Max. speed</b>	314 rad/s 3,000 rpm	200 rad/s 2,100 rpm	314 rad/s 3,000 rpm	628 rad/s 6,000 rpm	
<b>Min. frequency<sup>4)</sup></b>	2 x 10 <sup>-8</sup> Hz				
<b>Max. frequency</b>	100 Hz	200 Hz			
<b>Normal force range</b>	0.001 N to 50 N	0.01 N to 70 N	0.001 N to 50 N		
<b>Normal force resolution</b>	0.1 mN				
<b>TruStrain</b>	○	✓	✓	✓	✓
<b>Ready for DMA in tension, bending and compression<sup>5)</sup></b>	×	✓	✓	✓	✓
<b>Ready for axial-torsional DMA<sup>5)</sup></b>	×	×	×	✓	✓
<b>Dimensions (W x H x D)</b>	453 mm x 725 mm x 673 mm	453 mm x 775 mm x 673 mm		MCR 703 MultiDrive: 453 mm x 775 mm x 673 mm MCR 703 Space MultiDrive: 300 mm x 775 mm x 584 mm MCR 703 Space electronics box: 333 mm x 231 mm x 576 mm	
<b>Weight</b>	48 kg	50 kg	MCR 703 MultiDrive: 50 kg MCR 703 Space MultiDrive: 52 kg	MCR 703 MultiDrive: 60 kg MCR 703 Space MultiDrive: 62 kg	MCR 703 Space electronics box: 16 kg

Trademarks: RheoCompass (9177015), MultiDrive (16731581), TwinDrive Rheometry (7081128), SmartPave (16731556), T-Ready (9176983), Toolmaster (3623873), TruRate (9176967), TruRay (15273915), TruStrain (9176918)

Patents: US Pat. 8453496, 9766172, 9574983, 10908058, 8132445, 10031057, 9702809, AT Pat. 513661, DE Pat. 102015100714

✓ Included ○ Optional × Not included

- 1) US Pat. 8453496
- 2) 1 nNm with activated TruStrain™ option
- 3) In controlled shear stress (CSS) mode. In controlled shear rate (CSR) mode depending on measuring point duration and sampling rate
- 4) Theoretical value (duration per cycle = 2 years)
- 5) US Pat. 9574983 and US Pat. 10908058

# The Rheo Academy



Find out more

## Sign up for our rheology courses and webinars

We regularly offer courses at our global subsidiaries and also organize online courses or exclusive group courses for customers on request.

Learn the basics of rheology, optimize your work with the RheoCompass software, and gain application-specific knowledge. You can also learn more about specialist subjects and meet our experts for discussions online by taking part in one of our free webinars.

## Enjoy access to an extensive database of knowledge

As a customer, enjoy access to a large database of useful application reports, product documentation, and tutorial videos. Benefit from our comprehensive background knowledge on rheological theory (e.g., through our wiki and the book *Applied Rheology* by renowned expert Thomas Mezger).

## Get in touch with our experts

We provide excellent service and support. With Anton Paar subsidiaries and numerous partners worldwide, a rheological expert is close to you and happy to help. Call us for advice on test definitions or to discuss the rheological challenges you're facing.



## Reliable. Compliant. Qualified.



**Our well-trained and certified technicians are ready to keep your instrument running smoothly.**

Maximum uptime | Warranty program | Short response times | Global service network

