

OPNE8008B

**QVGA TIME-OF-FLIGHT SENSOR
EVALUATION KIT**

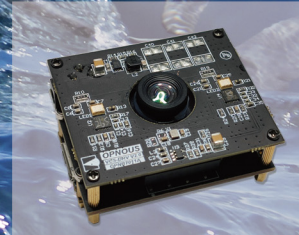

Echolocation of Lipotes vexillifer appears to adapt to various distance in navigation or ranging, sometimes up to 150 meters.

FUNCTIONAL DESCRIPTION

The OPNE8008B is our Evaluation Kit for the QVGA OPN8008D Time-of-Flight (ToF) Sensor. This Evaluation Kit is fully assembled and tested camera system designed for the evaluation of the OPN8008D QVGA ToF Sensor, which provides all necessary hardware to operate OPN8008D, including both the camera lens and illumination. It can be directly connected to a PC for real-time visualization and recording of depth map data, while allowing direct access to many configuration settings. The system is fully controllable by an intuitive GUI on a PC.

The OPNE8008B is a modular plug-and-play platform perfectly set up for customization. It is a standalone 3D ToF distance measurement camera system. The Kit consists of three independent stacked PCBs (from top to bottom: illumination board, ToF sensor board and interface board).

It is possible to detach the top two PCBs from the bottom PCB by bypassing the board to board connection with an external cable suitable for MIPI communication. The Evaluation Kit provides a flexible development environment for the design engineer.

A graphical user interface for Windows is provided for live depth map visualization, basic recording, analysis and configuration. For custom SW development, a Linux and Windows SDK is provided. The built-in flexibility of our Evaluation Kit enables any designer to develop the necessary system know-how and product experience for use in their application.

The Eval Kit is available in variants with either 86°x 68° field-of-view (FOV) with 850nm VCSEL illumination or 40°x 30° FOV with 940nm VCSEL illumination.

KEY FEATURES

- OPN8008D QVGA (320x240) ToF Chipset
- Vcsel illumination, FOV 86°x68°/40°x30°, 850nm/940nm
- Operating range up to 10m
- Full Resolution Accuracy<1%
- Distance & confidence data at max. 120 FPS
- Ambient operating temperature range -20°C ~85°C
- Built-in temperature sensor& Smart Correction
- 120 Klux sunlight rejection
- CIS-2 serial data output, MIPI D-PHY, 1 clock lane, 2 data lanes
- PC connectivity with USB3.0
- Raw data mode
- GUI, Windows & Linux SDK

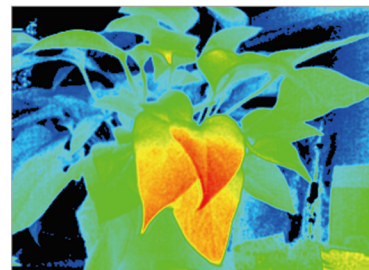

BLOCK DIAGRAM

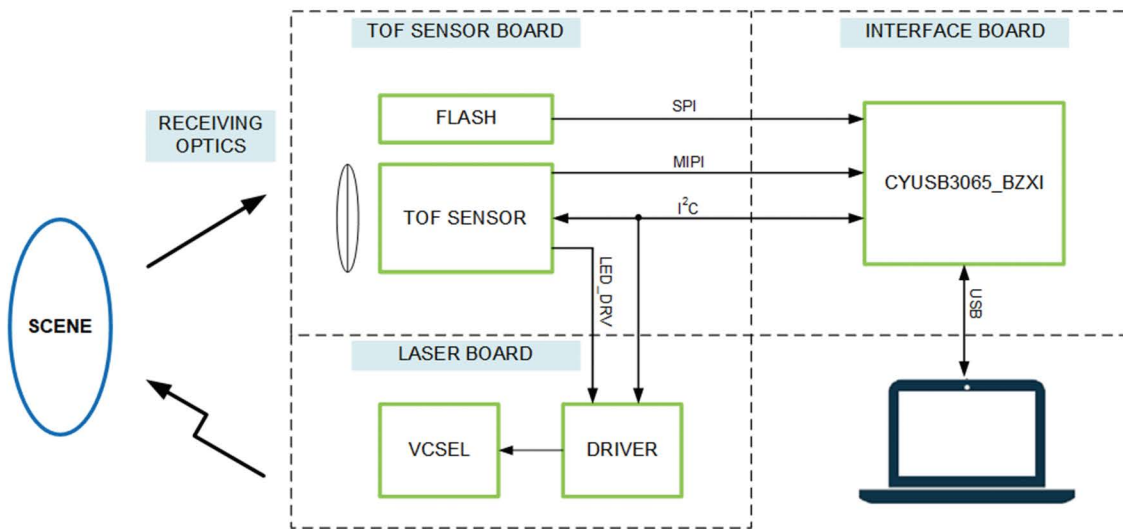

ILLUMINATION BOARD

- > 2x 2W VCSELS (86°x68°/40°x30°FOV, 850nm/940nm)
- > OPN7007Q VCSEL Driver
- > Programmable peak optical power
- > Onboard temperature sensor
- > Eye safety (certificate available)
- > DC3.5 Power Supply

TOF SENSOR BOARD

- > OPN8008D QVGA 320x240 Resolution
- > Standard S mount (M12 x 0.5) lens holder
- > F.NO 1.2 Lens with 850nm/940nm IR filter
- > 8Mb Flash onboard

INTERFACE BOARD

- > MIPI to USB bridge
- > USB3.0 data output

PACKAGE CONTENTS

- > 1x HW module
- > 1x DC3.5 cable
- > 1x USB3.0 cable
- > GUI for Windows
- > Windows & Linux SDK

APPLICATIONS

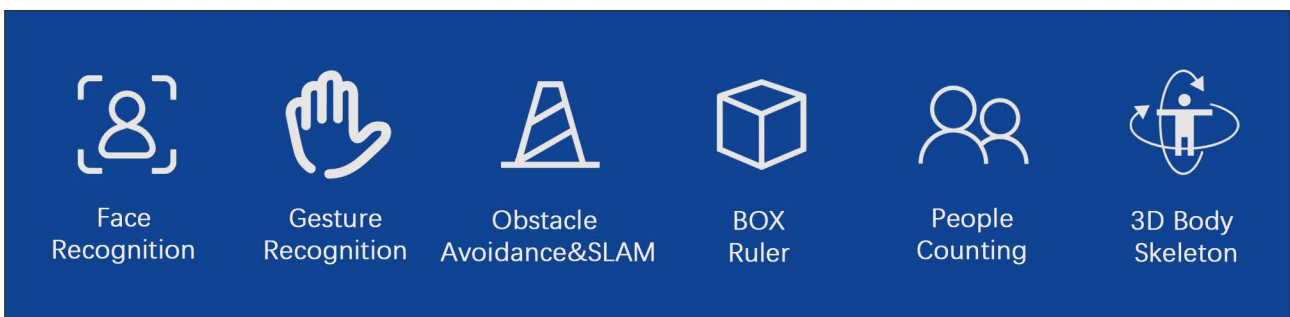

CONTACT INFORMATION

Headquarter

Phone: +86 21 62351683

Email: sales@opnous.com