

REV	Description	DATE	BY
A4A	Initial production Release.	11/19/2012	GC
A5	On the initial production release the processors were to be found incorrect as supplied by TI. Parts while marked AM3359 were actually AM3352. This revision uses the correct parts.	1/2/2013	GC
A5A	<ol style="list-style-type: none"> Deleted R29-R44 from the LCD lines. Added 47pf capacitors C156-C173 to LCD data lines to ground. Changed schematic revision to A5A. Changed a few footprints after PCB update for above changes. Added access point for the battery function of the TPS65217C. Added Ferrite beads in series with LED power and 5V power rail of the USB host connector. Required to pass FCC/CE testing due to noise emissions on that pin. Added power button to enable sleep, wakeup, power down and power up features on the system. Added Modification to add 100K ohm resistor to ground to prevent crosstalk when serial cable is not plugged in. 	2/8/2013	GC
A5B	<ol style="list-style-type: none"> Added 100K pull-down on J1 pin 4 to prevent crosstalk when serial cable is not connected into PCB layout. Changed the LED resistors to 4.75K to lower the brightness. 	5/21/2013	GC
A5C	<ol style="list-style-type: none"> Changed R46, R47, R48 to 0 ohms. Changed R45 to 22 Ohms. Change was made due to production failures on some boards due to differences in impedances.	6/12/2013	GC
A6	<ol style="list-style-type: none"> Moved the enable for the VDD_3V3B regulator to VDD_3V3A rail. Change was made to reduce the delay between the ramp up of the 3.3V rails. Added a AND gate to the SYS_RESETh circuitry. There is a small chance that on power up the nRESETOUT signal on the processor may go high, causing the SYS_RESETh signal to go HI before it should. This change reinforces the reset with the PORZn reset signal. Added optional zero ohm resistor to tie GND_OSC0 to system ground. 	7/25/2013	GC
A6A	<ol style="list-style-type: none"> Added optional zero ohm resistor to tie GND_OSC1 to system ground. Changed C106 to a 1uF capacitor. Changed C24 to a 2.2uF capacitor. Made R8 installed and R9 not installed. 	12/13/2013	GC
B	1. Changed the processor to the AM3358BZCZ100.	1/20/2014	GC
C	1. Increased the eMMC from 2GB to 4GB; The PCB revision for this board is Rev B6.	3/21/2014	GC
C3	<ol style="list-style-type: none"> Page 3: Added series resistor (R35,R36,R43,R44,R168-R173)=33R to the MMC1 lines. C175=DNI(10pF) to the MMC1_CLK to DGND; Changed C24 from 2.2uF to DNI. Page 4: Changed USB1_VBUS series resistor from FB8=0.1R 0805 to R37=0R 0402. Page 8: Connected the Pin A6 J5 of U13(eMMC IC) to DGND. Page 9: Added AM3358 GPIO1_8 and a Positive-AND gate(U1) to reset ethernet LAN8710A; Added series resistor (R38-R42)=33R to the LAN8710A TX lines; Changed (C137-C140) from DNI to 10pF. Page 11: Changed the MicroSD Connector from ALPS_SCHA5B0200 (EOL) to YU LIANG_YL004-030-001; Added series resistor (R2,R13,R15,R16,R31,R32)=33R and C5=DNI(10pF) to the MMC0 lines. The PCB Revision for this board is RevC, BOM is RevC3. 	4/1/2021	JQ.Xin

PAGE NO.	SCHEMATIC PAGE
1	COVER PAGE
2	POWER MANAGEMENT
3	PROCESSOR 1 OF 3, JTAG HEADER
4	PROCESSOR 2 OF 3, UAB PORTS
5	PROCESSOR 3 OF 3
6	LED, CONFIGURATION AND BUTTON
7	DDR3 MEMORY
8	eMMC FLASH
9	10/100 ETHERNET
10	HDMI FRAMER
11	EXP CONN, uSD

This schematic is ***NOT SUPPORTED*** and DOES NOT constitute a reference design. Only "community" support is allowed via resources at BeagleBoard.org/discuss.

THERE IS NO WARRANTY FOR THIS DESIGN, TO THE EXTENT PERMITTED BY APPLICABLE LAW. EXCEPT WHEN OTHERWISE STATED IN WRITING THE COPYRIGHT HOLDERS AND/OR OTHER PARTIES PROVIDE THE DESIGN "AS IS" WITHOUT WARRANTY OF ANY KIND, EITHER EXPRESSED OR IMPLIED, INCLUDING, BUT NOT LIMITED TO, THE IMPLIED WARRANTIES OF MERCHANTABILITY AND FITNESS FOR A PARTICULAR PURPOSE. THE ENTIRE RISK AS TO THE QUALITY AND PERFORMANCE OF THE DESIGN IS WITH YOU. SHOULD THE DESIGN PROVE DEFECTIVE, YOU ASSUME THE COST OF ALL NECESSARY SERVICING, REPAIR OR CORRECTION.

beagleboard.org

Title		BeagleBone Black Cover Page	
Size	Document Number	Rev	
B	450-5500-001	C3	
Date:	Thursday, April 01, 2021	Sheet	1 of 11

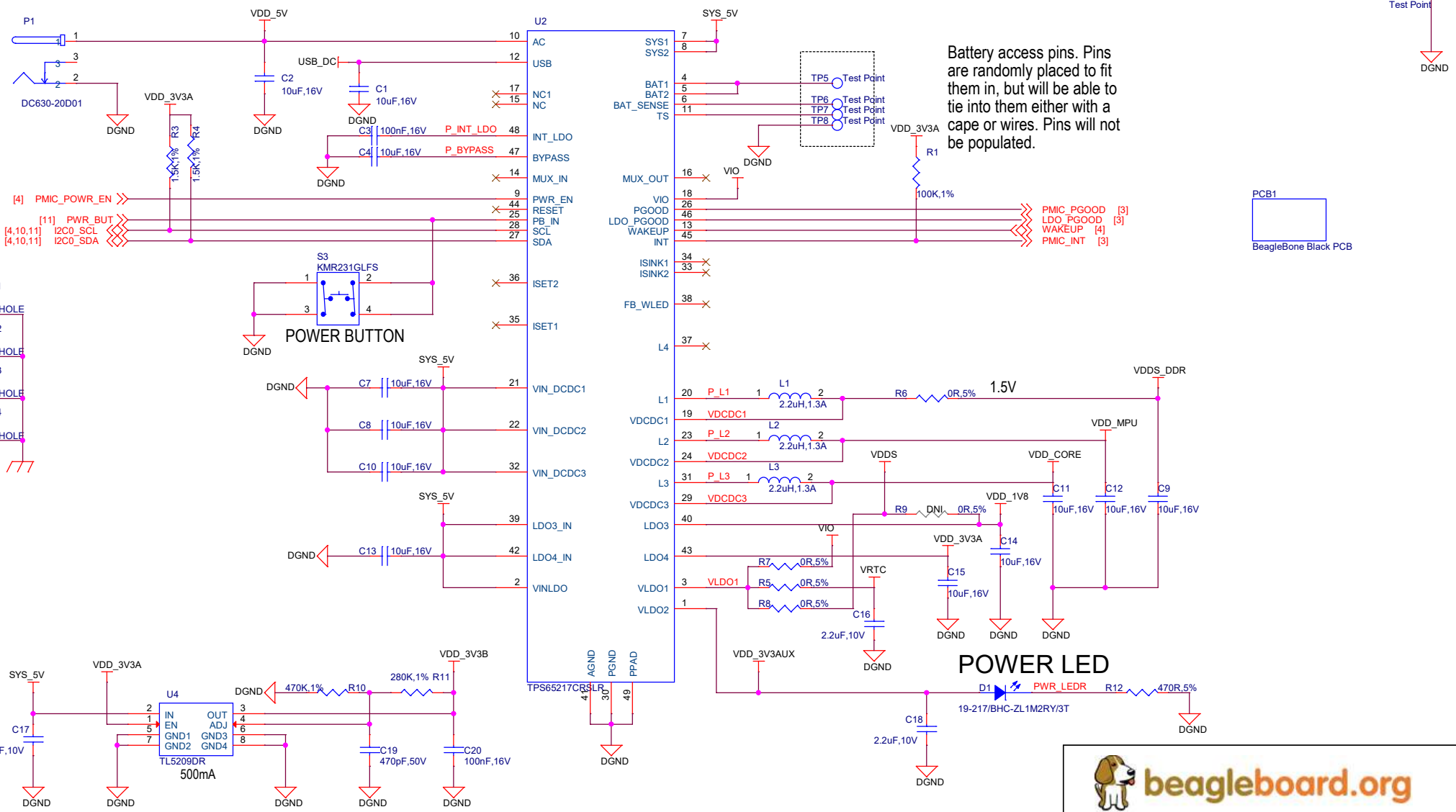

Battery access pins. Pins are randomly placed to fit them in, but will be able to tie into them either with a cape or wires. Pins will not be populated.

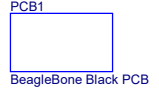

beagleboard.org

Title		
BeagleBone Black Power Management		
Size	Document Number	Rev
B	450-5500-001	C3
Date:	Tuesday, February 23, 2021	Sheet 2 of 11

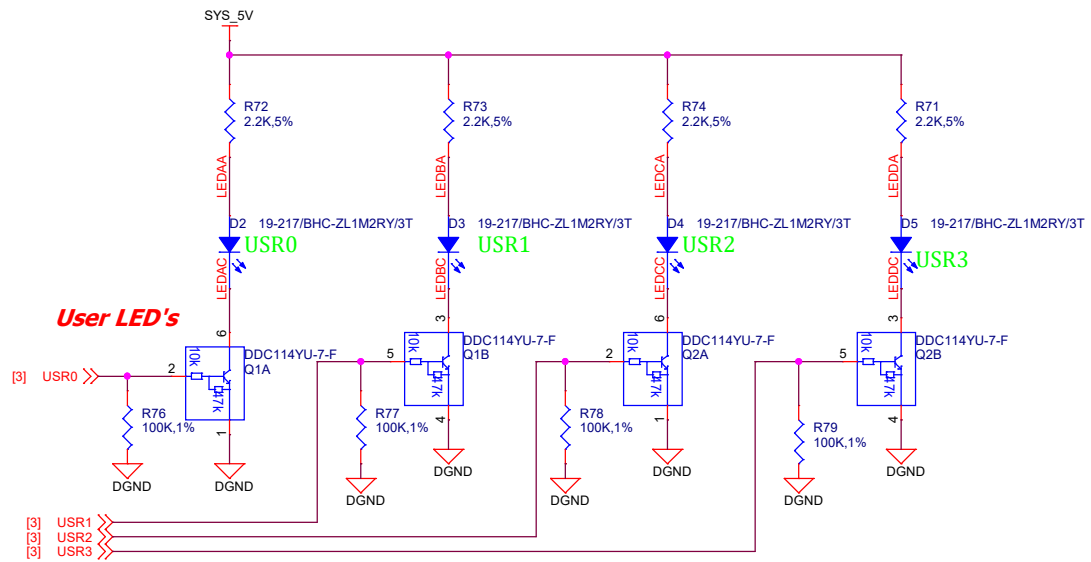
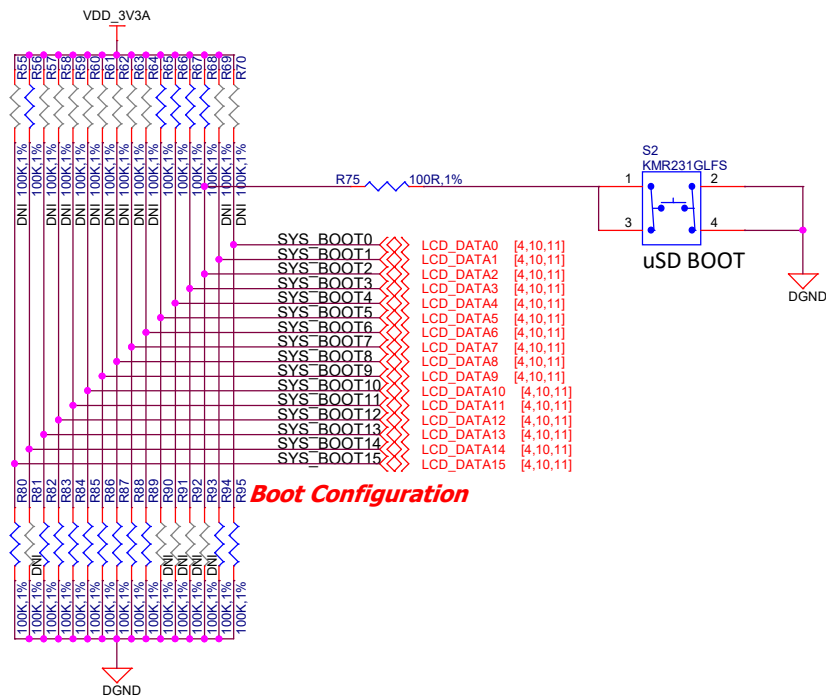

SYSBOOT[15:14]	SYSBOOT[13:12]	SYSBOOT[11:10]	SYSBOOT[9]	SYSBOOT[8]	SYSBOOT[7:6]	SYSBOOT[5]	SYSBOOT[4:0]	Boot Sequence			
00b = 19.2MHz 01b = 24MHz 10b = 25MHz 11b = 26MHz	00b (all other values reserved)	Don't care for ROM code	Don't care for ROM code	Don't care for ROM code	Don't care for ROM code	0 = CLKOUT1 disabled 1 = CLKOUT1 enabled	11100b	MMC1	MMC0	UART0	USB0[5]
00b = 19.2MHz 01b = 24MHz 10b = 25MHz 11b = 26MHz	00b (all other values reserved)	Don't care for ROM code	Don't care for ROM code	Don't care for ROM code	Don't care for ROM code	0 = CLKOUT1 disabled 1 = CLKOUT1 enabled	11000b	SPI0	MMC0	USB0[5] 1	UART0



Title			BeagleBone Black LED, Configuration, and Reset		
Size	Document Number				Rev
B	450-5500-001				C3
Date:	Monday, December 21, 2020	Sheet	6	of	11

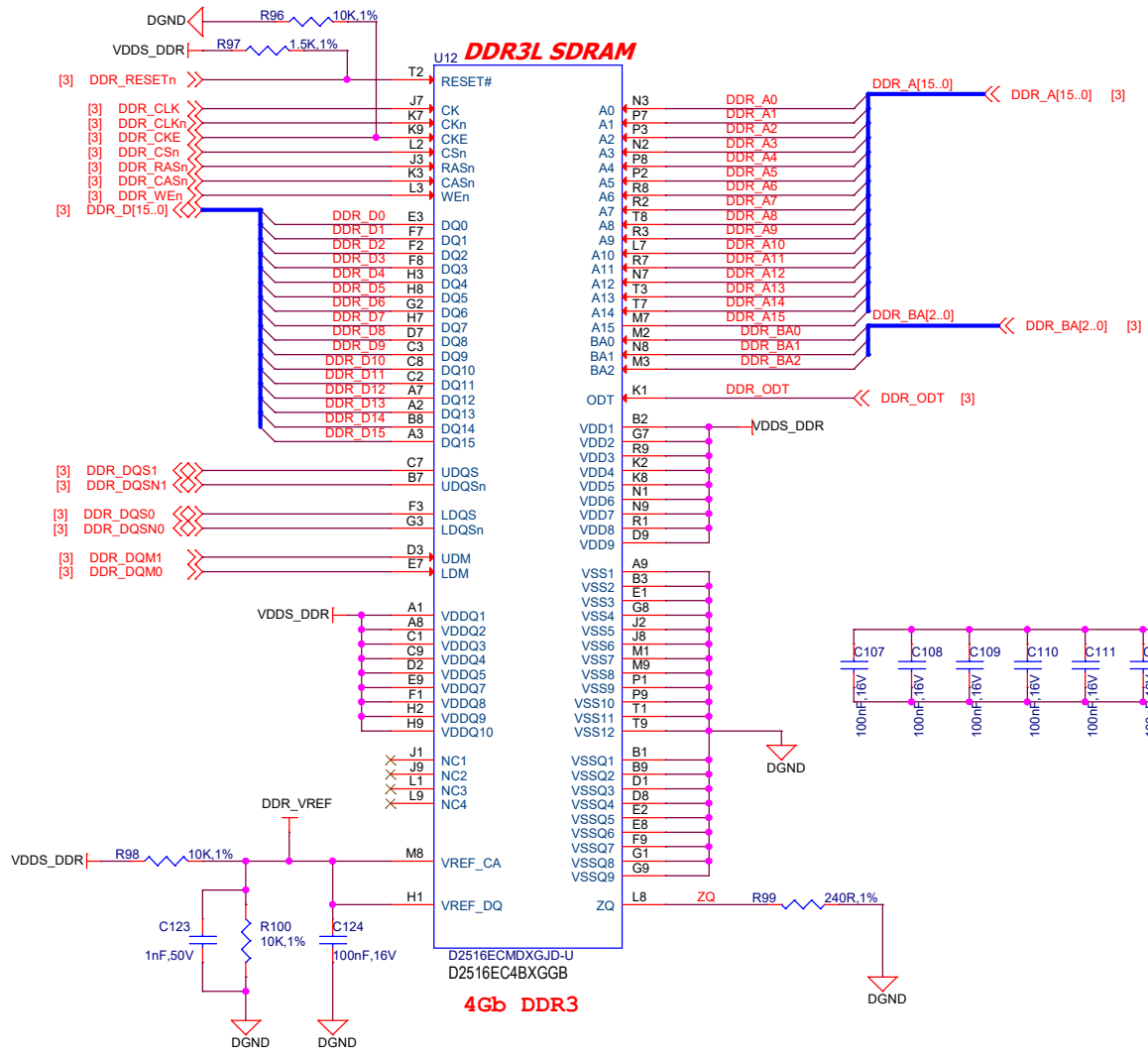

Title		
BeagleBone Black DDR3 Memory		
Size	Document Number	Rev
B	450-5500-001	C3
Date:	Monday, December 21, 2020	Sheet 7 of 11

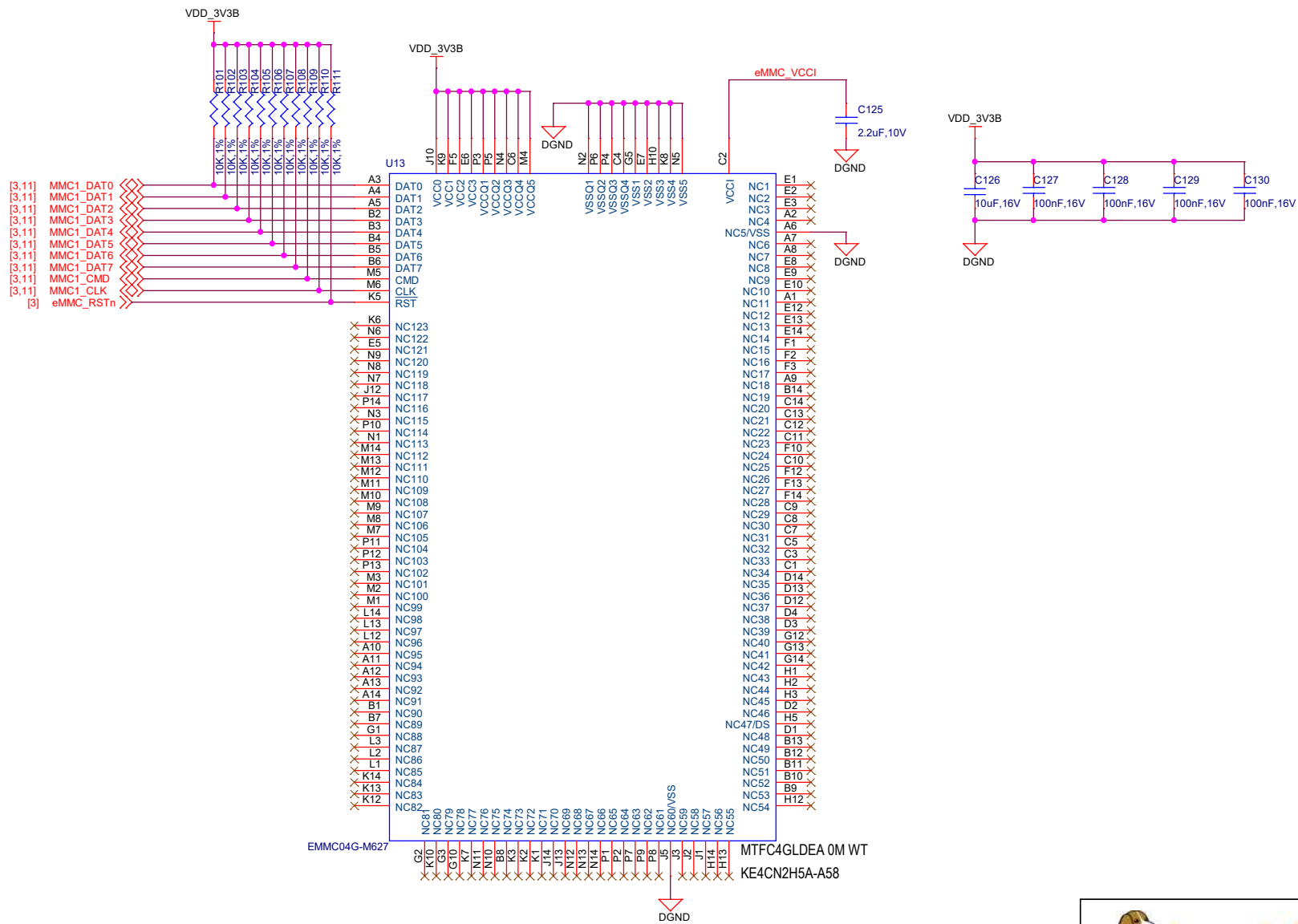

Title		BeagleBone Black 4G eMMC	
Size	Document Number	Rev	
B	450-5500-001	C3	
Date:	Friday, December 25, 2020	Sheet	8 of 11

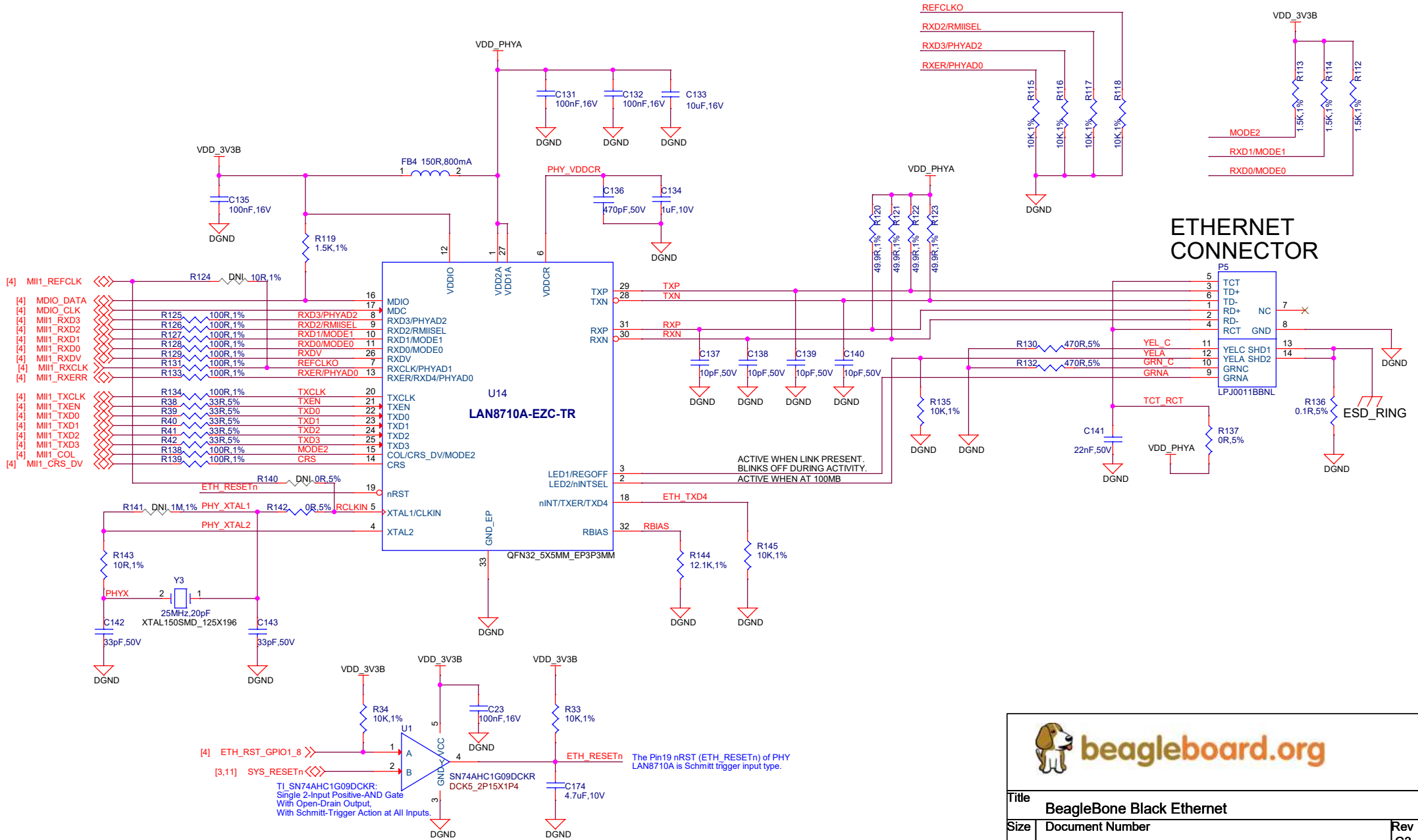

Title		BeagleBone Black Ethernet	
Size	Document Number	Rev	
B	450-5500-001	C3	
Date:	Monday, December 21, 2020	Sheet	9 of 11

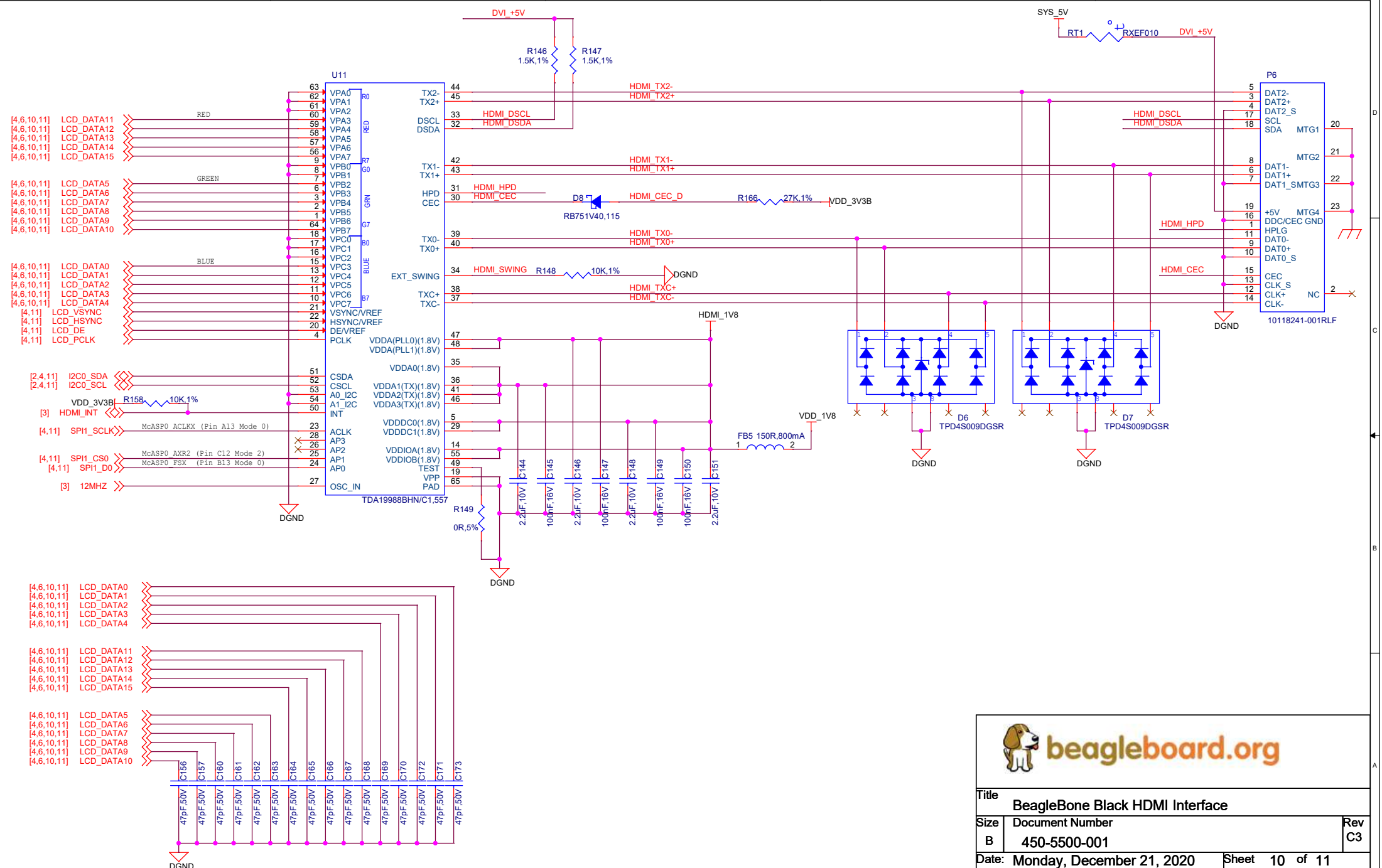

Title		
BeagleBone Black HDMI Interface		
Size	Document Number	Rev
B	450-5500-001	C3
Date:	Monday, December 21, 2020	Sheet 10 of 11

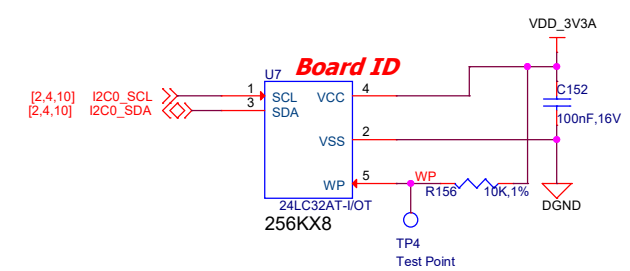
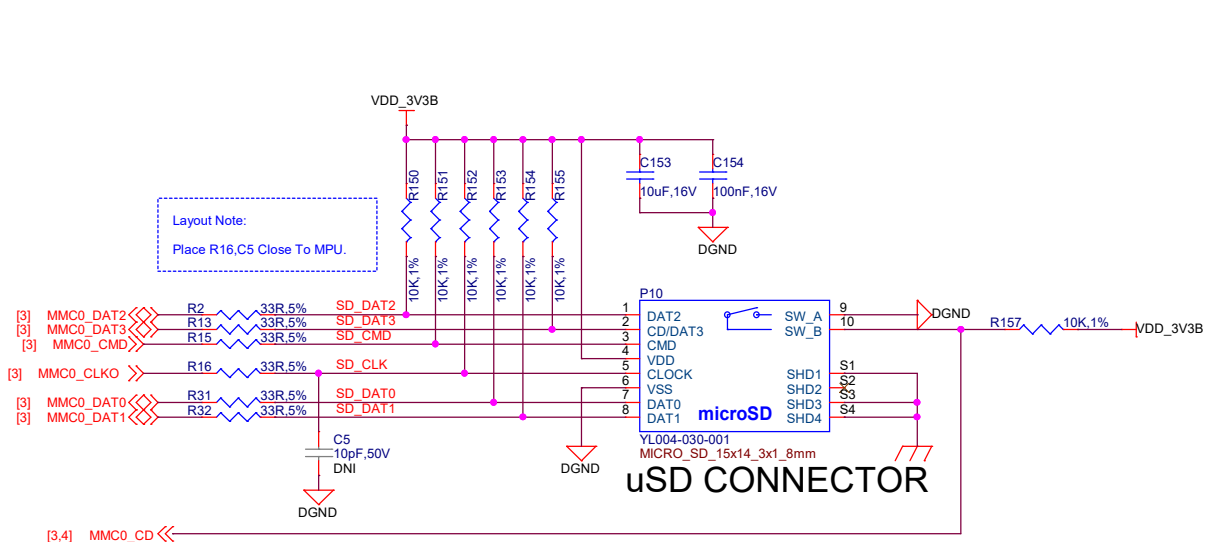
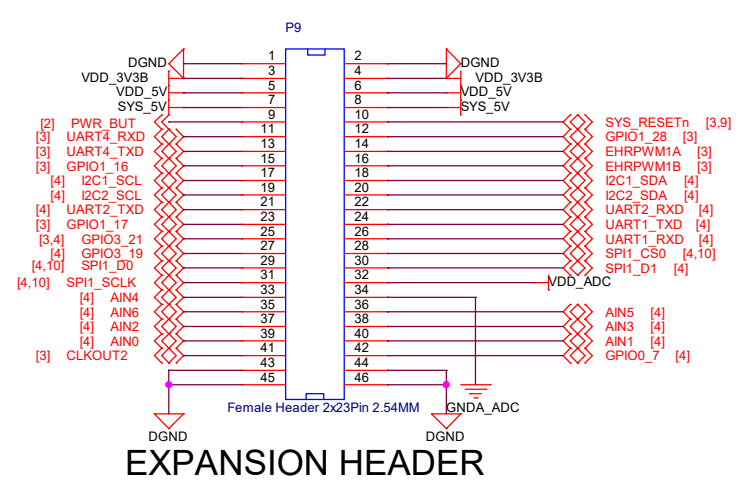
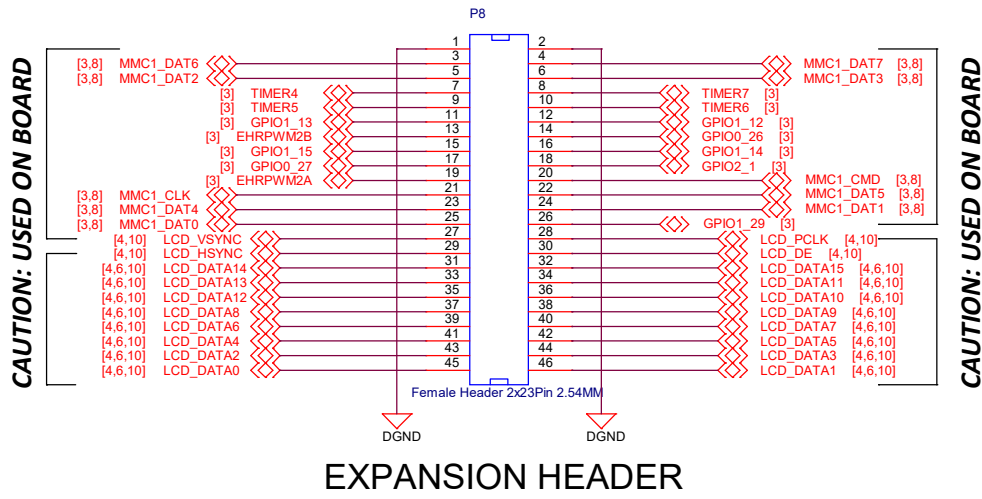

beagleboard.org

Title: BeagleBone Black Expansion Headers, uSD and EEPROM

Size	Document Number	Rev
B	450-5500-001	C3
Date:	Monday, February 22, 2021	Sheet 11 of 11