

Modelling

with Differential
and Difference
Equations

Bernardo Galvão-Sousa
Jason Siefken

Inquiry Based Modelling with Differential and Difference Equations

© Galvão-Sousa-Siefken, 2019–2020
Creative Commons By-Attribution Share-Alike



For the student

This book is your introductory guide to mathematical modelling and modelling with differential and difference equations. It is divided into *modules*, and each module is further divided into *exposition*, *practice problems*, and *core exercises*.

The *exposition* is easy to find—it’s the text that starts each module and explains the big ideas of modelling and differential or difference equations. The *practice problems* immediately follow the exposition and are there so you can practice with concepts you’ve learned. Following the practice problems are the *core exercises*. The core exercises build up, through examples, the concepts discussed in the exposition.

To optimally learn from this text, you should:

- Start each module by reading through the *exposition* to get familiar with the main ideas. In most modules, there are some videos to help you further understand these ideas, you should watch them after reading through the exposition.
- Work through the *core exercises* to develop an understanding and intuition behind the main ideas and their subtleties.
- Re-read the *exposition* and identify which concepts each core exercise connects with.
- Work through the *practice problems*. These will serve as a check on whether you’ve understood the main ideas well enough to apply them.

The core exercises. Most (but not all) core exercises will be worked through during lecture time, and there is space for you to work provided after each of the core exercises. The point of the core exercises is to develop the main ideas of modelling with differential or difference equations by exploring examples. When working on core exercises, think “it’s the journey that matters not the destination”. The answers are not the point! If you’re struggling, keep with it. The concepts you struggle through you remember well, and if you look up the answer, you’re likely to forget just a few minutes later.

Contributing to the book. Did you find an error? Do you have a better way to explain a concept? Please, contribute to this book! This book is open-source, and we welcome contributions and improvements. To contribute to/fix part of this book, make a *Pull Request* or open an *Issue* at <https://github.com/bigfatbernie/IBLModellingDEs>. If you contribute, you’ll get your name added to the contributor list.

For the instructor

This book is designed for a one-semester introductory modelling course focusing on differential and difference equations (MAT231 at the University of Toronto).

Each module contains exposition about a subject, practice problems (for students to work on by themselves), and core exercises (for students to work on with your guidance). Modules group related concepts, but the modules have been designed to facilitate learning modelling rather than to serve as a reference.

Using the book. This book has been designed for use in large active-learning classrooms driven by a *think, pair-share*/small-group-discussion format. Specifically, the *core exercises* (these are the problems which aren’t labeled “Practice Problems” and for which space is provided to write answers) are designed for use during class time. *practice problems* were designed for students to practice at home by themselves and include some more computational exercises, and *projects* were designed to be solved through teamwork during tutorials with an assistant around to provide guidance.

A typical class day looks like:

1. **Student pre-reading.** Before class, students will read through the relevant module.
2. **Introduction by instructor.** This may involve giving a broader context for the day's topics, or answering questions.
3. **Students work on problems.** Students work individually or in pairs/small groups on the prescribed core exercise. During this time the instructor moves around the room addressing questions that students may have and giving one-on-one coaching.
4. **Instructor intervention.** When most students have successfully solved the problem, the instructor refocuses the class by providing an explanation or soliciting explanations from students. This is also time for the instructor to ensure that everyone has understood the main point of the exercise (since it is sometimes easy to miss the point!).
If students are having trouble, the instructor can give hints and additional guidance to ensure students' struggle is productive.

5. **Repeat step 3.**

Using this format, students are thinking (and happily so) most of the class. Further, after struggling with a question, students are especially primed to hear the insights of the instructor.

Conceptual lean. The *core exercises* are geared towards concepts instead of computation, though some core exercises focus on simple computation. They also have a modelling lean. Learning algorithms for solving differential and difference equations is devalued to make room for modelling and analysis of equations and solutions.

Specifically lacking are exercises focusing on the mechanical skills of algorithmic solving of differential and difference equations. Students must practice these skills, but they require little instructor intervention and so can be learned outside of lecture (which is why core exercises don't focus on these skills).

Real-World problems. The *projects* have a more open ended or real-world lean. They are meant to give students some practice dealing with "messy" data or having to build their own model and assess it. They should be incorporated into the course alongside the core exercises, so that students get a taste of both the conceptual and practical aspects of modelling. Information is sometimes purposefully lacking and students are encouraged to find it out by themselves: by experimentation, internet consultation, or just by reasoning.

How to prepare. Running an active-learning classroom is less scripted than lecturing. The largest challenges are: (i) understanding where students are at, (ii) figuring out what to do given the current understanding of the students, and (iii) timing.

To prepare for a class day, you should:

1. **Strategize about learning objectives.** Figure out what the point of the day's lesson is and brainstorm some examples that would illustrate that point.
2. **Work through the core exercises.**
3. **Reflect.** Reflect on how each core exercise addresses the day's goals. Compare with the examples you brainstormed and prepare follow-up questions that you can use in class to test for understanding.
4. **Schedule.** Write timestamps next to each core exercise indicating at what minute you hope to start each exercise. Give more time for the exercises that you judge as foundational, and be prepared to triage. It's appropriate to leave exercises or parts of exercises for homework, but change the order of exercises at your peril—they really do build on each other.

A typical 50 minute class is enough to get through 1–3 core exercises (depending on the difficulty), and class observations show that class time is split 50/50 between students working and instructor explanations.

License

Unless otherwise mentioned, pages of this document are licensed under the Creative Commons By-Attribution Share-Alike License. That means, you are free to use, copy, and modify this document provided that you provide attribution to the previous copyright holders and you release your derivative work under the same license. Full text of the license is at <http://creativecommons.org/licenses/by-sa/4.0/>

If you modify this document, you may add your name to the copyright list. Also, if you think your contributions would be helpful to others, consider making a pull request, or opening an *issue* at <https://github.com/bigfatbernie/IBLModellingDEs>

Incorporated content. Content from other sources is reproduced here with permission and retains the Author's copyright. Please see the footnote of each page to verify the copyright.

Included in this text, in chapter 1, are expositions adapted from the handbook “Math Modeling: Getting Started and Getting Solutions” by K. M. Bliss, K. R. Fowler, and B. J. Gallizzo, published by SIAM in 2014 <https://m3challenge.siam.org/resources/modeling-handbook>.

Contributing. You can report errors in the book or contribute to the book by filing an *Issue* or a *Pull Request* on the book's GitHub page: <https://github.com/bigfatbernie/IBLModellingDEs/>

Contributors

This book is a collaborative effort. The following people have contributed to its creation:

- Stephanie Orfano
- Yvan Saint-Aubin
- Sarah Shujah
- Graeme Slaght
-

Contents

1 Mathematical Modelling	2
Module 1: Defining the Problem	3
1	5
2	6
Module 2: Building a mind map	7
3	9
4	10
Module 3: Making assumptions	11
5	13
6	15
Module 4: Construct a model	17
7	19
Module 5: Model Assessment	21
8	23
Module 6: Putting it all together	25
2 First-Order Differential Equations	28
Module 7: Introduction to Differential Equations	29
Module 8: Solutions of Differential Equations	31
9	35
10	36
11	37
12	38
Module 9: Slope Fields	39
13	41
14	42
15	43
16	44
Module 10: Approximating Solutions	45
17	49
18	50
19	51
Module 11: Modelling with Differential Equations	53
20	59
21	61

Module 12: Solvable Types of ODEs	63
12.1. Separable Differential Equations	63
12.2. First-Order Linear Differential Equations	65
22	69
23	70
Module 13: Properties of Differential Equations	71
24	75
25	76
26	77
27	78
Module 14: Autonomous Differential Equations	79
28	83
29	84
30	86
3 Models of Systems	88
Module 15: Modelling Two Quantities	89
31	93
32	94
Module 16: Systems of two linear ODEs with constant coefficients	95
3.1 Two real and distinct eigenvalues	96
3.2 Two complex eigenvalues	96
3.3 One real repeated eigenvalue	98
33	101
34	102
35	103
Module 17: Phase Portraits	105
36	111
37	112
38	113
Module 18: Analysis of Models with Systems	115
39	121
4 Higher-Order Models	124
Module 19: Modelling with Second-Order ODEs	125
40	129
41	130
Module 20: Second-Order Linear ODEs with Constant Coefficients	131
4.1 Homogeneous ODEs	131
4.2 Non-Homogeneous ODEs	133

42	137
43	138
44	139
Module 21: Analysis of Models with Higher Order ODEs	141
45	145
46	146
5 Difference Equations	148
Module 22: Introduction to Difference Equations	149
Module 23: Solving Difference Equations	151
23.1. Expanding to find a pattern	151
23.2. Educated Guessing	152
47	155
48	156
Module 24: Modelling with Difference Equations	157
24.1. Economic Models	157
24.2. Probability Models	158
24.3. Population Models	158
49	161
50	162
51	163
52	164
53	165
Module 25: Analysis of Difference Equations	167
54	171
55	172
56	174
6 Projects	176
Project 1: Ecology of dragons	177
Project 2: Influencers	179
Project 3: Elephants: too much is too much!	181
Project 4: Managing a fishery	183
Project 5: X-ray attenuation	185
Project 6: Predator-prey chase	187
Project 7: Epidemic modelling	189
Project 8: Hunting inspiration	191

Project 9: Arms race	193
Project 10: Spring data	195
Project 11: Wing flutter	197
Project 12: Bullwhip effect	201
Project 13: Approximating the temperature of a thin sheet	205
Project 14: Math of lungs	207
Project 15: Dark day	209
Project 16: Maximus vs Commodus	211
7 Appendix	214
7.1 Linear Algebra Review	215
7.2 Mathematical Induction Review	218

In this section, we study some strategies to model problems mathematically in an effective manner. We also provide a structure to modelling problems by breaking them in small parts:

1. Define the problem
2. Build a mind map
3. Make assumptions
4. Construct a model
5. Analyze the model
6. Write a report

In this chapter, we follow the approach of

Math Modeling: Getting Started and Getting Solutions, K. M. Bliss, K. R. Fowler, and B. J. Galluzzo, SIAM, Philadelphia, 2014

<https://m3challenge.siam.org/resources/modeling-handbook>



and

GAIMME: Guidelines for Assessment and Instruction in Mathematical Modeling Education, Second Edition, Sol Garfunkel and Michelle Montgomery, editors, COMAP and SIAM, Philadelphia, 2019

<http://uoft.me/gaimme>

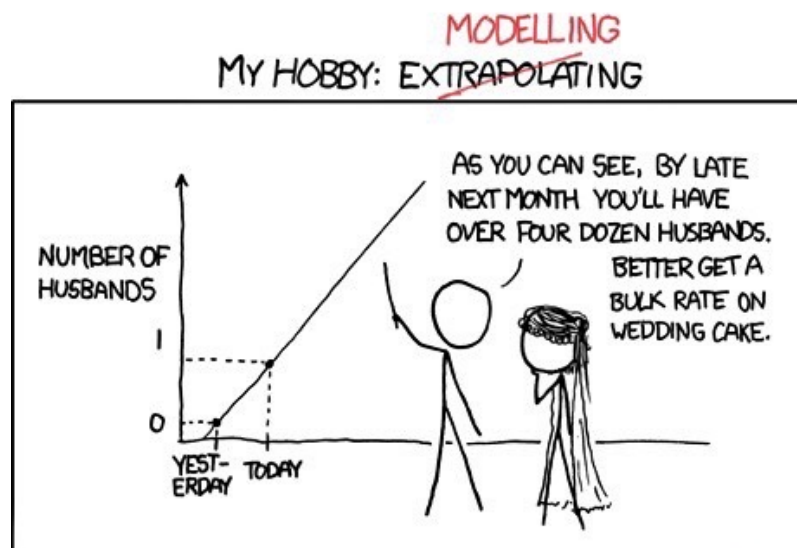

(image adapted from xkcd - comic #605)

Defining the Problem

In this module you will learn

- how to define a problem mathematically.

The first step is to define the problem we want to solve.

Important. To do this, we should start from the end!

We need to decide on what kind of mathematical object we will use in the end to show that we solved the problem we were tasked with.

Mathematical Object. A “mathematical object” can take several forms:

- a whole or real number (this type of object is the most popular);
- a vector of numbers;
- a function;
- an equation, an inequality;
- a geometrical shape: in the design of a school building or a protective helmet;
- a graph, as for the study of a subway line, of the fluidity of the Internet or for the study of the danger during a spill of a dangerous substance on a road near sources of drinking water.

Despite your love for numbers, stay open to all “mathable” objects.

Once this is done, we can define the problem mathematically.

Example. Your team was tasked with optimizing the layout of an airport.

The team decided to define:

- T = the total time (in minutes) necessary by the average person to walk from their airport transportation (taxi, train, bus) to their gate, disregarding the time spent in security or immigration.

At the end of the project, to show that the team did find a good layout for the airport, the team will show that the new layout reduces the value of T .

Once this decision is made, the problem to solve (or improve) becomes clear:

- Minimize T

Practice Problems

For each exercise, what “mathematical object” would you use to communicate that you have solved or improved the problem? Then define the problem mathematically.

- 1 Help the city of Toronto choose the best recycling system.
- 2 Help the Canadian Institute of Health Information (CIHI) estimate how significant the outbreak of illnesses will be in the coming year in Canada.
- 3 Create a mathematical model to rank roller coasters according to thrill factor.
- 4 Gas stations offer different prices for gas. I would like to create an app that finds the best gas station to go to. What should “best” mean?
- 5 Is it better to buy or rent?

- (a) Is it better to buy a car or rent Zipcar, or Car2go?
 - (b) Does the criteria you used to evaluate the previous question change if the question is whether to buy a bicycle or use Bike Share Toronto?
- 6 Help Airbus design the interior of an airplane.

1 You are hired by theBigCompany to help with their “elevator problem”.

This is the email you received:

—— Forwarded Message ——

Date: Monday, 7 September 2020 21:41:35 + 0000

From: CEO <theCEO@theBigCompany.ca>

To: Human Resources <hr@theBigCompany.ca>

Subject: they're still late!

Hey Shophika!

I still get complaints about staff being late, some by 15 minutes.

With the staff we have, that's about one salary lost.

Again the bottleneck of the elevators seems to be the problem.

Can you suggest solutions?

Thanks, the CEO

(problem adapted from GAIMME, SIAM <http://uoft.me/gaimme>)

What mathematical object would you use to convince the CEO that you have solved or improved the problem?

Teamwork.

With your team, you must decide on *one* answer and be prepared to report on your decision and the reason for your choice.

The mayor of Toronto wants to extend the subway line with a new orange line as in the figure below.



(Map taken from Wikimedia Commons created by Craftwerker)



- 2.1 What “mathematical object” would you use to communicate that to the Mayor that this line is optimal (or sub optimal) ?
- 2.2 Define the problem mathematically.

Building a mind map

In this module you will learn

- How to create a mindmap.

A mind map is a tool to visually outline and organize ideas. Typically a key idea is the centre of a mind map and associated ideas are added to create a diagram that shows the flow of ideas.

Example.

Let us focus on the question: “What is the best recycling system for Toronto?”

Then we can think of many different definitions for what the word “best” means:

- The system that gets the most participation from the population, which can be measured by the fraction of the Toronto households participating in recycling;
- The system that costs the least amount of money for the city. How can this be measured?
- The system that processes the most amount of recyclables.

In the figure below, we focus on the definition of “best”, with these three possible definitions branching off to be further explored.

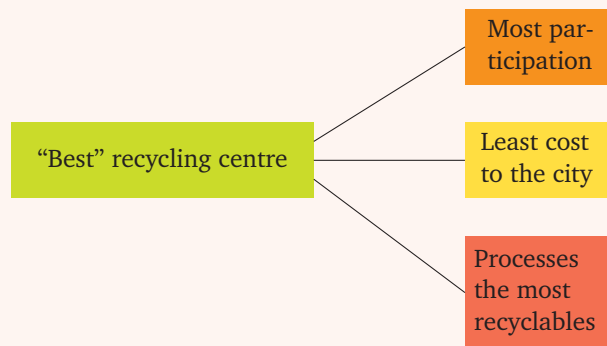

From here, we can focus our attention on one of the branches at a time.

Let’s think about the least-cost option first.

We probably can’t determine how much any recycling program costs without knowing more about the recycling program, so a good place to start is to ask the question “What kinds of recycling programs exist?”

If we aren’t familiar with different types of recycling, we might need to do some research to see what kinds of programs exist.

A possible next step on your mind map for the least-cost approach could be the one shown below.

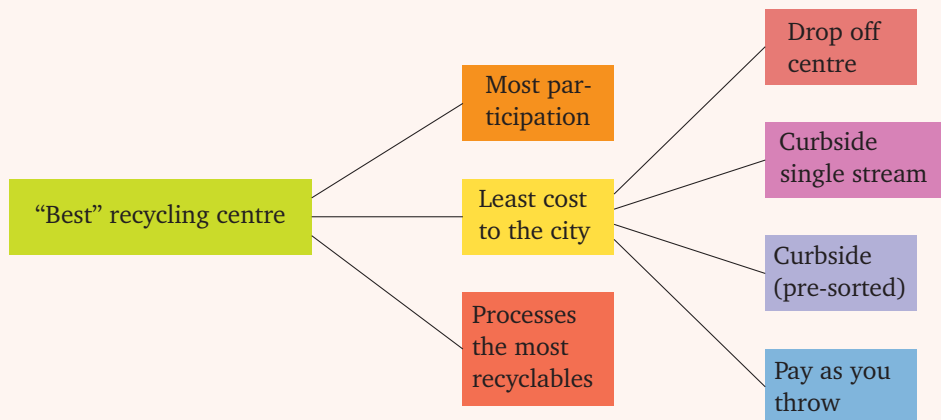

Important. There is free online software to help creating a mind map. One such is FreeMind (<http://freemind.sourceforge.net>).



For more details on creating a mind map, check the book:

Math Modeling: Getting Started and Getting Solutions, K. M. Bliss, K. and B. J. Galluzzo, SIAM, Philadelphia, 2014

<https://m3challenge.siam.org/resources/modeling-handbook>



Practice Problems

- 1 Expand the mind map from the example above by focusing on the other two approaches:
 - (a) Most participation
 - (b) Processes the most recyclablesFor each part, create a mind map. Focus on the same approach you had for the questions from the previous module.
- 2 Help the Canadian Institute of Health Information (CIHI) estimate how significant the outbreak of illnesses will be in the coming year in Canada.
- 3 Create a mathematical model to rank roller coasters according to thrill factor.
- 4 Gas stations offer different prices for gas. I would like to create an app that finds the best gas station to go to. What should “best” mean?
- 5 The mayor of Toronto wants to extend the subway line with a new orange line as in core exercise 2. Is it optimal?
- 6 Is it better to buy a car or rent Zipcar, or Car2go?
- 7 Help Airbus design the interior of an airplane.

3

Consider the elevator problem from question 1.

Your team decides that the mathematical object you will use to show the CEO that you solved or improved the problem is

- T = the sum in minutes by which every employee is late.

Note that employees that are on time count for 0 minutes (not a negative amount of minutes).

Create a mind map for the question: How can T be minimized?

4 The city of Toronto decided to tear down the Gardiner expressway. While the demolition is taking place, several key arteries are closed and many intersections are bottled. At peak times, a police officer is often posted at this intersection to *optimally* control the traffic lights.

4.1 What mathematical meaning can we give to the word optimal in this circumstance?

4.2 Create a mind map for this problem.

Making assumptions

In this module you will learn

- that we need to make assumptions to be able to create a model
- how to strike a balance between accuracy and solvability
- that it is crucial to inform future users of your model of its assumptions and conditions

Real problems are complex, so when modelling a real problem mathematically, we must make some assumptions. The assumptions that we make will affect the problem we are solving and its difficulty, so we need to strike a balance between:

- accuracy – the fewer assumption the better, and
- solvability – the more assumptions the better.

Many assumptions follow naturally when building a mind map.

When figuring which assumptions to make, keep in mind the key-factors of the problem and find data when available (usually online). If not available, measure data when possible, and if it's not possible, make a *reasonable* assumption on what the data might look like.

Another thing to keep in mind are **time constraints**. Whether in a class, test, or working in a project, there will be deadlines. Your assumptions should take your time constraints into consideration.

Example.

Let us revisit the example of the previous module about the “best” recycling centre. For this example, imagine that the team decided on focusing their attention on the least cost to the city through building drop off centres.

For this, we need to find out how many people would make use of the drop-off centres (termed “likelihood of participation”).

The two extremes would be to assume that 100% of the people near a recycling centre would use it or that none would use it. Neither of these seems like a reasonable assumption, so what would be a better assumption?

Maybe the best idea is to do some investigation and see if there has been any successful research on participation rates in drop-off centres.

The team found a study that had been done in Ohio (that would have to be cited in the report) that estimated that about 15% of households participated in drop-off centre recycling, and made an assumption that this rate would hold in every city across the U.S..

One might ask if it is safe to assume that across the U.S. 15% of households will participate in drop-off centre recycling if it is available. Is it true that residents of Arizona will behave the same way residents of Ohio do? Certainly some cities would garner a participation rate much higher than 15%, while other cities would have a significantly lower participation rate. In fact, what are the chances that any city would actually have a participation rate of exactly 15%?

In some sense, one might say that assigning one participation rate to every city across the U.S. is a ridiculous assumption.

In response to that line of thinking, remember two things:

- First, remember that **one must make assumptions in order to make a model**. It is not practical or feasible to poll every citizen of every city to determine who will bring recyclables to a drop off centre. If we had to rely on data with that level of certainty at every juncture of the modelling process, we would never get any work done.

It's practical and important to make reasonable assumptions when we cannot find data.

- Second, you are developing a model that is intended to help one understand some complex behaviour or assist in making a complex decision. It is not likely to predict the exact outcome of a situation, only to help provide insight and predict likely outcomes. When you **provide a list of your assumptions**, you've done your part to inform anyone who might use your model. They can decide whether they think your assumption is or is not appropriate to model the behaviour they are interested in predicting.

Practice Problems

For each part, you are required to make an estimate for some quantity. Make assumptions and justify them in order to solve the problem.

- 1 What is the number of piano players in Toronto?
(Fermi problem)
- 2 How many linear km of roads are there in Toronto?
- 3 How much salt the city of Toronto needs for its roads during the Winter?
- 4 The skating season in Canada is shortening: What are the key-factors determining its length?
- 5 How much soy sauce is consumed daily in Toronto?
- 6 How high would the Niagara Falls need to be so that Toronto could be powered by the Lewinston hydro power plant alone?
- 7 How much nuclear fuel would be needed per year to power Toronto using the Pickering nuclear power plant alone?
- 8 How many tennis balls are used in the World per year?
- 9 How many screws are in the Eiffel tower?

5

Consider the elevator problem from core exercise 1. We now give you some technical details about theBigCompany:

- The company occupies the floors 30–33 of the building Place Ville-Marie in Montréal.
- Personnel is distributed in the following way:
 - 350 employees in floor 30,
 - 350 employees in floor 31,
 - 250 employees in floor 32,
 - 150 employees in floor 33.

Note. Even though these details are fictional, the numbers respect the building code.

Hint. Focus on a **few** parameters and variables.

- 5.1 With your team, decide on what kind of information you would need to have to be able to solve this problem.
- 5.2 Find the relevant information about the elevators (search the internet, by experimentation). Check the reliability of the data you found.
- 5.3 For the relevant information that you cannot obtain, make assumptions. These assumptions should be reasonable and you should be able to justify them.

— Forwarded Message —

Date: Monday, 7 September 2020 21:41:35 +0000
From: CEO <theCEO@theBigCompany.ca>
To: Human Resources <hr@theBigCompany.ca>
Subject: they're still late!

Hey Shophika!

I still get complaints about staff being late, some by 15 minutes.

With the staff we have, that's about one salary lost. Again the bottleneck of the elevators seems to be the problem.

Can you suggest solutions?

Thanks, the CEO

(problem adapted from GAIMME, SIAM
<http://uoft.me/gaimme>)

Construct a model

In this module you will learn

- how to build a model based on the previous steps

This is the part of the modelling where we connect all that we have done so far: the problem we defined, the mind map, the assumptions, and all the variables and parameters in a mathematical model to answer the “mathematical” problem defined in Module 1.

With the problem statement clearly defined and an initial set of assumptions made (a list that will likely get longer), you are ready to start to define the details of your model. Now is the time to pause to ask what is important that you can measure. Identifying these notions as variables, with units and some sense of their range, is key to building the model.

The purpose of a model is to predict or quantify something of interest.

Creating a model usually means writing down mathematical equations, constructing a graph, analyzing a geometric figure, or do some statistical analysis.

Example. Your team is tasked with finding the best recycling centre (we looked at this example in Module 2 and your team has chosen to minimize the cost to the city by using drop off centres.

As part of modelling process, your team has made the following assumptions/measurements:

- People would be willing to pay \$2.29 to recycle per month or \$0.53 per week
- People would make one weekly trip to the centre
- Gasoline costs around \$1.26 per litre
- On average a passenger car consumes 10 litres per hundred kilometres

This means that the (one-way) distance people are willing to travel every week to the drop-off centre is

$$d = \frac{1}{4.3 \text{ trips/month}} \cdot \frac{\$2.29/\text{month}}{(\$1.26/\text{L}) \cdot (0.1 \text{ L} / \text{km})} = 4.2 \text{ km/trip.}$$

This should help us figure out the best way to place the drop-off centres.

The Mathematical model might look like this

- Maximize (number of people within a 4.2 km radius of a drop-off centre)
- subject to a certain number of drop-off centres (given by the city budget)

Assuming that this project was requested for a specific city, the final report should also include some suggested locations for various different budgets.

Practice Problems

For each question, create a model to answer the question. Remember all the previous steps.

- 1 Describe the possible positions of the hands in a clock.
- 2 You want to open a piano store in Toronto, where should you open it?
- 3 There was a big snow storm in Toronto and the roads need cleaning. How should the city deploy its snow plowers?
- 4 The city of Toronto wants to deactivate the Pickering nuclear power plant in favour of renewable power sources. What is the best way to create the same amount of electricity using only renewable sources in the GTA?
- 5 Loblaws wants to start an online food delivery service. How should they do it?
- 6 The city airport (YTZ) built a tunnel to access the island airport from the city. Before that, they used a ferry. Was building the tunnel a good decision?

7

Recall the core exercise 5.

- The company occupies the floors 30–33 of the building Place Ville-Marie in Montréal.
- Personnel is distributed in the following way:
 - 350 employees in floor 30,
 - 350 employees in floor 31,
 - 250 employees in floor 32,
 - 150 employees in floor 33.

Write down a mathematical model for this problem.

Teamwork.

Each team should have *one* model and be prepared to present it to the class.

— Forwarded Message —

Date: Monday, 7 September 2020 21:41:35 +0000
From: CEO <theCEO@theBigCompany.ca>
To: Human Resources <hr@theBigCompany.ca>
Subject: they're still late!

Hey Shophika!

I still get complaints about staff being late, some by 15 minutes.

With the staff we have, that's about one salary lost. Again the bottleneck of the elevators seems to be the problem.

Can you suggest solutions?

Thanks, the CEO

(problem adapted from GAIMME, SIAM
<http://uoft.me/gaimme>)

Model Assessment

In this module you will learn

- how to analyze a model
- to check the quality of the model

At this point, you have defined a problem statement, and a mind map to help you decide how to approach the problem. You have made assumptions and made note of them and justified them. You finally created a model to solve the problem.

The next step is to analyze the model.

There are two types of analysis:

Superficial assessment. Are the units correct? Are the variables and parameters of a reasonable magnitude? Does it behave as expected? Does it make sense?

In-depth assessment. Once the superficial assessment is verified, we need to understand the model at a deeper level.

What are the model's strengths? What are its weaknesses?

When you change the inputs of the model, how do the outputs change? This is called **sensitivity analysis**.

Example. Modelling the flu

History of the project:

- Split population into two classes: *infected* and *not infected*
- Assume that each infected person infects R number of non infected people every b days
- Define $I(n)$ = number of infected people after n days
- The two previous points imply $I(n + b) = I(n) + RI(n)$
- We can then conclude that $I(nb) = (1 + R)^n I(0)$ (why?)

After plotting the resulting function $I(n)$ (with $R = 5$, $b = 2$, $I(0) = 20$), we can assess our model.

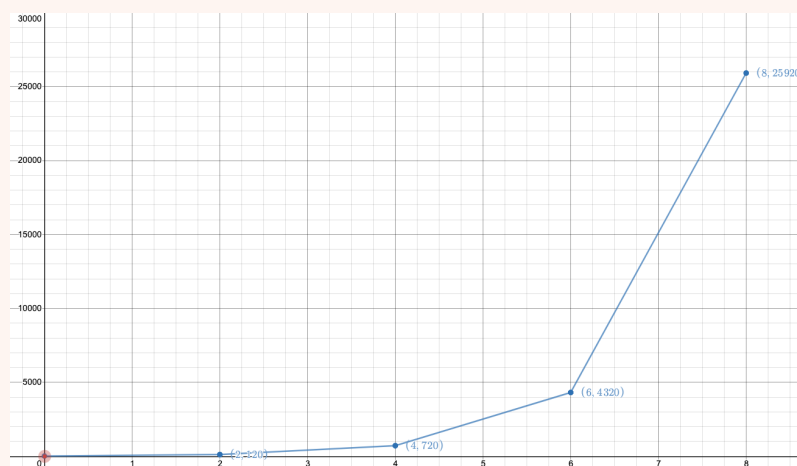

- <https://www.desmos.com/calculator/deh5qeea20>



Strengths:

- After two days ($b = 2$), there are 6 infected people, so it is following our assumption
- The number of infected people increases faster and faster as expected
- The disease spreads at a constant rate. Also on Desmos, check the infection rate $\frac{I(n+b)}{I(n)}$
- We could find an explicit formula for the number of infected individuals $I(n)$

Weaknesses:

- The model is too simple, so it doesn't model the spread of the flu accurately
- The model yields an exponential rate of infection, which is not possible for very long
- The model predicts that eventually the disease will spread to everyone
- The model assumes that there are only two types of people: infected and susceptible. Do people recover from the disease?

After assessing the model, if time allows, it is important to re-think the model and the assumptions made.

Practice Problems

Assess the models created for the practice problems from the previous module.

- 1 You want to open a piano store in Toronto, where should you open it?
- 2 There was a big snow storm in Toronto and the roads need cleaning. How should the city deploy its snow plowers?
- 3 The city of Toronto wants to deactivate the Pickering nuclear power plant in favour of renewable power sources. What is the best way to create the same amount of electricity using only renewable sources in the GTA?
- 4 Loblaws wants to start an online food delivery service. How should they do it?
- 5 The city airport (YTZ) built a tunnel to access the island airport from the city. Before that, they used a ferry. Was building the tunnel a good decision?

Continuing on the elevator problem, let us think of this model for the problem.

Facts:

- Loading time of people at ground floor = 20 s
- Speed of uninterrupted ascent/descent = 1.5 floors/s
- Stop time at a floor = 7 s
- Number of elevators serving floors 30–33 = 8
(these elevators serve floors 23-33 = 11 floors)
- Maximal capacity of elevators = 25 people

Assumptions:

- Personnel that should start at time t , arrive uniformly in the interval $[t - 30, t - 5]$ in minutes
- First arrived, first served
- During morning rush hour, elevators don't stop on the way down
- Elevators stop only at half the floors they serve
- Elevator failures are neglected
- Mean number of people per floor is equal to the mean number of people per floor of the BigCompany
- Elevators are filled, in average, to 80% of their capacity

Model:

- Mean number of people per floor = $d = \frac{350 + 350 + 250 + 150}{4} = 275$ people / floor
- Number of people on floors served by elevators (11 floors) = $N = d \cdot 11 = 3025$ people
- Time Δt of one trip

$$\Delta t = \boxed{\text{loading time on ground floor}} + \boxed{\text{time of flight ground} \rightarrow 33} + \boxed{\text{time of flight 33} \rightarrow \text{ground}} + \boxed{\text{stop time to 6 of the 11 floors}} = 106 \text{ s}$$

- Number of trips necessary per elevator = $n = \frac{3025}{20 \cdot 8} \approx 19$ trips
- Time necessary to carry the staff of the BigCompany = $t = \frac{19 \cdot 106}{60} = 33$ minutes
- Accumulated late time = $T = 180 \cdot 20 \cdot 8 + 74 \cdot 20 \cdot 8 = 40\,640$ seconds = 11h18m

Your task is to assess this “model” (first estimate of the number of minutes employees are late). Be ready to report on your assessment.

Teamwork.

Each team should have *one* assessment and be prepared to present it to the class.

Putting it all together

In this module you will learn

- how to put all that you have done together into a well structured report

This is the final stage of the modelling project.

By now, you have started with a mathematically defined problem, with some assumptions, and you have created a mind map to help you navigate the problem. You have also constructed a model and assessed it to make sure it is sound.

All that we have left is to put all this work together into the form of a report.

The report should consist of two parts:

1. **Summary.** Should be at most one page long, and contain a statement of the problem, a brief description of the methods chose to solve it, and some final results and a conclusion. In this part of the report, you should keep mathematical symbols to a minimum, so the reader gets an idea of what to expect in the remainder of the report without getting bogged down in unfamiliar mathematics.
2. **In-depth report.** This is where the details go in. It should start with an introduction to the problem assuming that the reader is not aware of it. It should then be structured according to the steps we did before:
 - Optionally, you can include a mind map with a description of how it guided the whole process
 - Assumptions and variables in the model
 - The model described in detail
 - The solution process
 - The assessment of the model
 - A conclusion, with a description of the results

Example. As an example of an excellent report, please read the report from the winning team of the 2019 M_3C challenge:

- <https://uoft.me/modelling-app-report>



- Read the summary and chapters 1, 2, 5.

Report checklist.

Component	Questions about your model and how you made it	Useful vocabulary
Defining the problem	What is/are the big problem/s that you have been asked to solve?	open-ended problem
	What is the specific problem your model is going to solve?	specific, focus
Making assumptions	What ideas did you think about that you decided not to try?	eliminate, prioritize
	What have you assumed in order to solve the problem? Why did you make these choices?	assumption, constraints
	What quantities are important? Which ones change and which ones stay the same?	variable
	Where did you find the numbers that you used in your model?	resources, citations
Getting a solution	What pictures, diagrams or graphs might help people understand your information, model, and results?	diagram, graph, labels
	What mathematical ideas did you use to describe the situation and solve your problem?	situation
Model assessment	How do you know that your calculations are correct? Did you remember to use units (like dollars or metres?)	calculation, unit
	When does your model work? When do you need to be careful because it might not?	limitations
	How do you know you have a good/useful model? Why does your model make sense?	testing, validation
	If you were going to make your model better, what would you do?	improvement, iteration
Reporting results	Explain your mathematical model in words and math.	clarity, concision
	What are the strengths and weaknesses of your model?	strengths, weaknesses
	What are the 5 most important things for your audience/client to understand about your model and/or solution?	client, audience

This checklist is adapted from

GAIMME: Guidelines for Assessment and Instruction in Mathematical Modeling Education, Second Edition, Sol Garfunkel and Michelle Montgomery, editors, COMAP and SIAM, Philadelphia (2019)

<https://uoft.me/gaimme>





LIBERAL-ARTS MAJORS MAY BE ANNOYING SOMETIMES, BUT THERE'S *NOTHING* MORE OBNOXIOUS THAN A PHYSICIST FIRST ENCOUNTERING A NEW SUBJECT.

(image from xkcd - comic #793)

Introduction to Differential Equations

Differential Equation. A *differential equation* is an equation involving an unknown function and one or more of its derivatives.

Among differential equations, there are lots of types, that require different approaches, so we need to classify them.

Types of Differential Equations. There are two main types of differential equations:

- **Ordinary differential equations**, usually denoted as ODEs: when the unknown function is a function of one variable;
- **Partial differential equations**, usually denoted as PDEs: when the unknown function is a function of several variables.

In this book, we are going to focus only on ordinary differential equations.

Among ordinary differential equations, we distinguish them according to:

- **order**: the order of a differential equation is the order of the highest derivative present in the differential equation;
- **linear** vs **nonlinear**: A differential equation $F(t, y, y', \dots, y^{(n)}) = 0$ is called **linear** if F is a linear function of $y, y', \dots, y^{(n)}$. Linear ODEs have the form

$$a_0(t)y(t) + a_1(t)y'(t) + \dots + a_n(t)y^{(n)}(t) = g(t).$$

All other differential equations are called **nonlinear**.

Roughly, to check whether an ODE is **linear**, we need to check that:

- The unknown y and its derivatives appear with exponent 1;
- The unknown y and its derivatives do not multiply by each other;
- The unknown y and its derivatives are not the “objects” of other functions – there are no occurrences of things like $\sin(y)$ or $e^{y'}$, $\ln(y'')$, $\sqrt{y^{(3)}}$, etc.

In general, when tackling a differential equation, linear ODEs are easier to solve and study than nonlinear.

In the following chapters, observe how the methods and theory for linear ODEs is much more developed. Nonlinear ODEs are usually tackled on a case-by-case basis, and there is no theory that applies to a class of nonlinear ODEs.

Fortunately, many important problems are modelled by linear equations.

A common approach to nonlinear problems is to “transform” them into a linear problem. This means that the new linear problem is easier to study, but will be an approximation of the original problem, and often that approximation is only reasonable within some restricted conditions.

Example. Consider the nonlinear ODE

$$y' = -\sin(y).$$

This is a nonlinear ODE.

However, by Taylor’s Theorem, we can approximate the function $\sin(y)$ by y , as long as $|y|$ is very small. So we can say that the solution of the original solution is very close to the solution of

$$y' = -y,$$

as long as $|y|$ is very small.

Solutions of Differential Equations

In this module you will learn

- what is a solution of a differential equation
- the difference between a solution and an integral curve

When we model a quantity through a differential equation, we will need to study its solution.

Solution. Given a differential equation, a **solution** is a differentiable function that satisfies the differential equation.

Example. Consider the differential equation

$$t \frac{du}{dt} = u + t^2 \cos(t).$$

Then the function

$$u(t) = t \sin(t)$$

is a solution, because

$$t \frac{du}{dt} = t(\sin(t) + t \cos(t)) = t \sin(t) + t^2 \cos(t) = u + t^2 \cos(t).$$

There are several different approaches to studying the solutions:

- finding an explicit or implicit formula for the solution,
- finding an approximation of the solution,
- or just finding some of its properties.

We will see all these approaches in the next modules.

Here we are interested in what it means to be a solution and the different types of solutions.

General solution. Given a differential equation, its **general solution** is an explicit or implicit formula for all the possible solutions of the differential equation.

Example. Consider the differential equation of the previous example:

$$t \frac{du}{dt} = u + t^2 \cos(t).$$

In the previous example we saw one of the solutions. In fact, all the possible solutions for this differential equation have the form:

$$u(t) = t(\sin(t) + C),$$

for an constant C .

This is called the **general solution** of the differential equation.

Roughly, the general solution of an n^{th} -order differential equation must contain n constants.

This means that the space of solutions of an n^{th} -order differential equation is a (affine) subspace of dimension n .

Integral curve. We can represent all the solutions geometrically as an infinite family of curves. These curves are called **integral curves**.

Example. Consider the initial-value problem

$$\begin{cases} \frac{dy}{dx} = -\frac{x}{y} \\ y(0) = -3 \end{cases}$$

Then, we can check that curves of the form $x^2 + y^2 = C$ satisfy this differential equation.

This gives us the solution

$$y(x) = -\sqrt{9 - x^2}.$$

However, the integral curve for this initial-value problem is the curve

$$x^2 + y^2 = 9$$

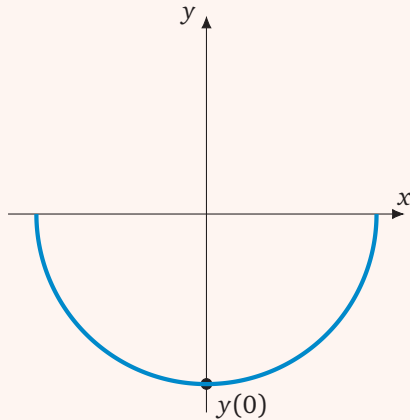

Solution of the initial-value problem

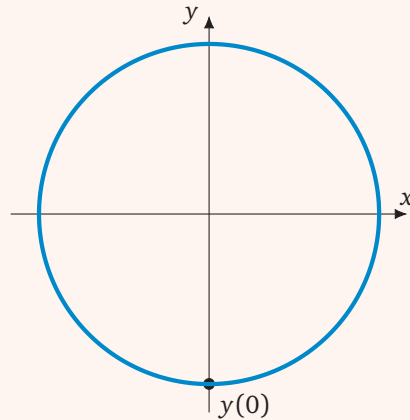

Integral curve for the initial-value problem

Practice Problems

- 1 Check that curves of the form $x^2 + y^2 = C$ satisfy the differential equation $\frac{dy}{dx} = -\frac{x}{y}$.
- 2 Is the piecewise-defined function

$$y(x) = \begin{cases} -x^2 & \text{if } x < 0 \\ x^2 & \text{if } x \geq 0 \end{cases}$$

a solution of the differential equation $xy' - 2y = 0$ on $(-\infty, \infty)$?

- 3 Consider the differential equation

$$y'''' - 8y'''' + 26y'' - 40y' + 25y = 0.$$

- (a) Is $y = 3e^{2x}$ a solution?
 (b) Is $y = 4e^{2x} \sin(x)$ a solution?
 (c) Is $y = -8xe^{2x} \cos(x)$ a solution?
 (d) For the three function above, if they are solutions, what are initial conditions of the form

$$\begin{aligned} y(0) &= \\ y'(0) &= \\ y''(0) &= \\ y'''(0) &= \end{aligned}$$

that the solution satisfies?

- 4 Consider the functions

$$\begin{aligned} f(x) &= 3x + x^2 & g(x) &= e^{-7x} \\ h(x) &= \sin(x) & j(x) &= \sqrt{x} \\ k(x) &= 8e^{3x} & \ell(x) &= -2\cos(x) \end{aligned}$$

Match each differential to one or more functions which are solutions.

- (a) $y' = 3y$
 (b) $y'' + 9y' + 14y = 0$
 (c) $y'' + y = 0$
 (d) $2x^2y'' + 3xy' = y$

- 5 Consider the differential equation $u' = -2(u - 10)$.

- (a) Check that the curves of the form $u = 10 + Ce^{-2t}$ satisfy the differential equation.
 (b) Sketch one solution of the differential equation.
 (c) Sketch all the integral curves for the differential equation.
 (d) What is the difference between a solution passing through the point $(1, 20)$ and an integral curve passing through the same point?

- 6 Consider the differential equation $y'(3y^2 - 1) = 1$.

- (a) Check that the curves of the form $y^3 - y = x + C$ satisfy the differential equation.
 (b) Sketch the solution of the differential equation that passes through $(1, 1)$.
 (c) Sketch the integral curve for the differential equation that passes through $(1, 1)$.

- (d) What is the difference between a solution passing through the point $(1, 1)$ and an integral curve passing through the same point?
- (e) Repeat (b)–(d) with the points $(1, 0)$ and $(1, -1)$ instead of $(1, 1)$.

7 Consider the ODE $y'(t) = (y(t))^2$. One of these two graphs **cannot** describe the solution. Which one?

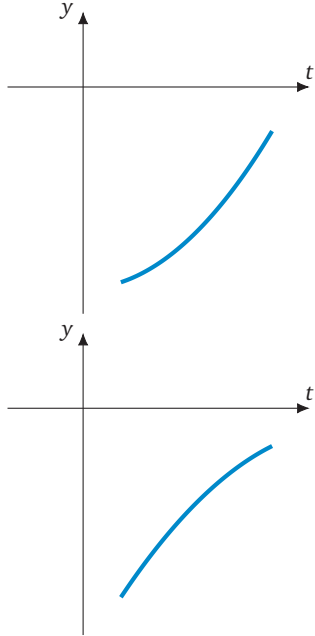

8 We seek a first-order ordinary differential equation $y' = f(y)$ whose solutions satisfy

$$\begin{cases} y(x) \text{ is concave up if } y < 1 \\ y(x) \text{ is concave down if } y > 1 \end{cases}$$

Write down or graph a function $f(y)$ that would produce such solutions.

9

Which of these shows solutions of $y' = (x - 1)(x + 1) = x^2 - 1$?

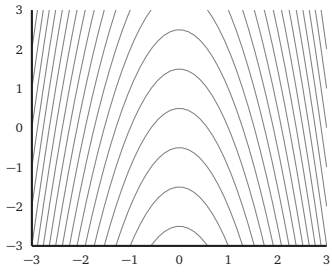

A

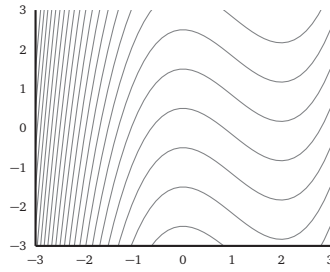

B

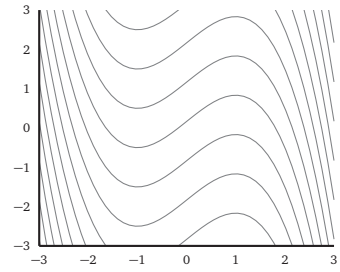

C

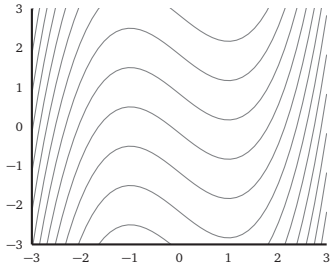

D

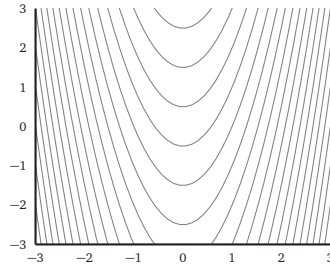

E

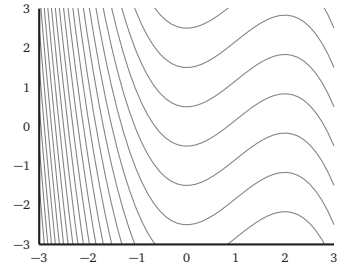

F

10 We seek a first-order ordinary differential equation $y' = f(x)$ whose solutions satisfy

$$\begin{cases} y(x) \text{ is increasing if } x < 2 \\ y(x) \text{ is decreasing if } 2 < x < 4 \\ y(x) \text{ is increasing if } x > 4 \end{cases}$$

Write down or graph a function $f(x)$ that would produce such solutions.

-
- 11 Consider the ODE $y'(t) = (y(t))^2$. Which of the following is true?
- 11.1 $y(t)$ must always be decreasing
 - 11.2 $y(t)$ must always be increasing

 - 11.3 $y(t)$ must always be positive
 - 11.4 $y(t)$ must always be negative

 - 11.5 $y(t)$ must never change sign.

12 Consider the differential equation $2xy' = y$.

- 12.1 Check that the curves of the form $y^2 + Cx = 0$ satisfy the differential equation.
- 12.2 Sketch one solution of the differential equation.
- 12.3 Sketch all the integral curves for the differential equation.
- 12.4 What is the difference between a solution passing through the point $(1, -1)$ and an integral curve passing through the same point?

Slope Fields

In this module you will learn

- what is a slope field
- how to sketch a slope field
- to interpret a slope field

As we saw in the previous module, once we have found a differential equation that models a situation, we often want to figure out what happens to the solution.

In this module, we will focus on getting an idea of the solutions and integral curves using what is called a **slope field**.

Slope field. Consider the differential equation $y' = f(x, y)$. If we evaluate $f(x, y)$ over a rectangular grid of points, and we draw an arrow at each point (x, y) of the grid with slope $f(x, y)$, then the collection of all the arrows is called a **slope field**.

We can sketch Slope Fields with Wolfram Alpha.

For a differential equation $\frac{dy}{dx} = f(x, y)$, we need to input

- Vector Field: $(1, f(x, y))$.

<http://www.wolframalpha.com/input/?i=slope+field>



Example. Let us take an example from the previous module.

Consider the initial-value problem

$$\begin{cases} \frac{dy}{dx} = -\frac{x}{y} \\ y(0) = -3 \end{cases}$$

We can use this definition to sketch the slope field for the differential equation $\frac{dy}{dx} = -\frac{x}{y}$.

We now sketch this slope field with Desmos:

<https://www.desmos.com/calculator/scmz6ps0or>



Now notice that the arrows have the slope of a solution. This means that solutions will be tangent to the arrows, so we can **roughly** trace the solution by following the arrows.

Below, we did just that starting with the point $(0, -3)$.

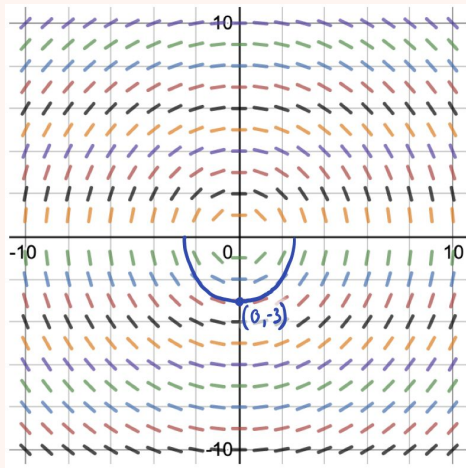

approximated solution

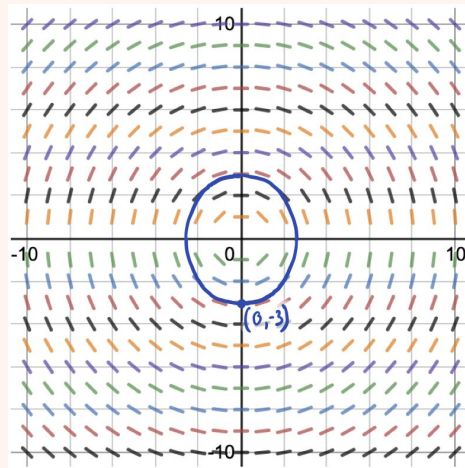

approximated integral curve

Important. Remember that this gives us only an approximation of the solution and integral curve. From the approximation, we can tell that the solution seems circular, but we still need to show that it is so.

Video.

■ <https://youtu.be/MI2xCwBekX4>

■ <https://youtu.be/8Amgakx5aII>



Practice Problems

1 Use Wolfram Alpha, Desmos, or another software to sketch the slope field for the following differential equations. Then roughly trace different solutions.

- (a) $y' = 2y - x$
- (b) $y' = xy$
- (c) $y' = \cos(y)$
- (d) $y' = \frac{1}{2} + \cos(y)$
- (e) $y' = 1 + \cos(y)$
- (f) $y' = 2 + \cos(y)$
- (g) $y' = \sin(xy)$
- (h) $y' = \tan(x + y)$

2 Sketch a slope field for the following differential equation

$$y' = f(x, y)$$

where

$$f(x, y) = \begin{cases} -x & \text{if } x < 1 \\ y & \text{if } x \geq 1 \end{cases}$$

3 Sketch a slope field for the following differential equation

$$y' = f(x, y)$$

where the function $f(x, y)$ satisfies all of the following properties:

- (a) $f(x, y)$ is continuous
- (b) $f(x, y) > 0$ when $x > 1$ and $y > 1$
- (c) $f(x, y) < 0$ when $x < -1$ and $y < -1$
- (d) $f(x, y)$ depends only on x when $x < -1$ and $y > 1$
- (e) $f(x, y)$ depends only on y when $x > 1$ and $y < -1$

4 (a) On the slope field from the previous problem, show that there must exist a smooth continuous curve with horizontal lines.

(b) Show that the curve divides the (x, y) plane in two parts.

5 Consider a differential equation

$$y' = f(x, y)$$

where the solutions satisfy

$$\lim_{x \rightarrow \infty} y(x) = 1.$$

- (a) What property must the slope field satisfy?
- (b) Sketch a possible slope field for this differential equation.

13 Consider the slope field from the first video of the module.

13.1 If $y(0) = 5$, then estimate $y(-7)$.

13.2 If $y(0) = a$, then $y(x) > 0$ for all $x > 0$. For which values of a is this statement true?

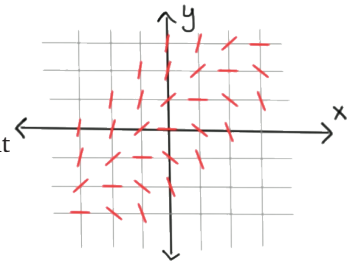

14

A catapult throws a projectile into the air and we track the height (in metres) of the projectile from the ground as a function $y(t)$, where t is the time (in seconds) that elapsed since the object was launched from the catapult.

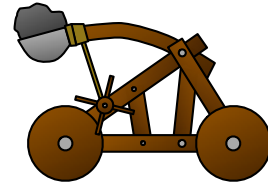

Then, the slope fields for $y(t)$ and $y'(t)$ are shown below:

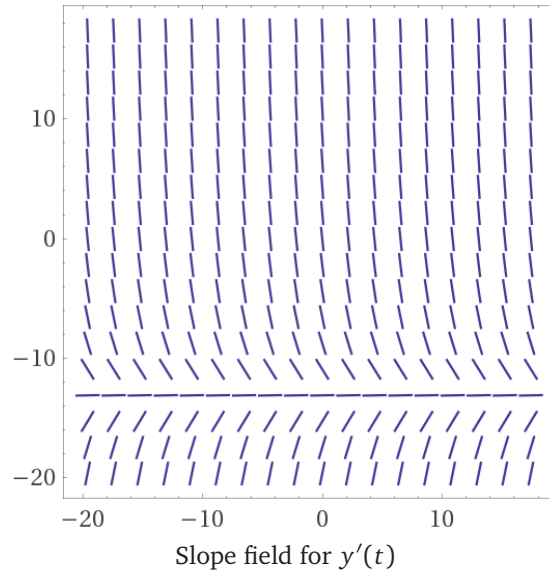
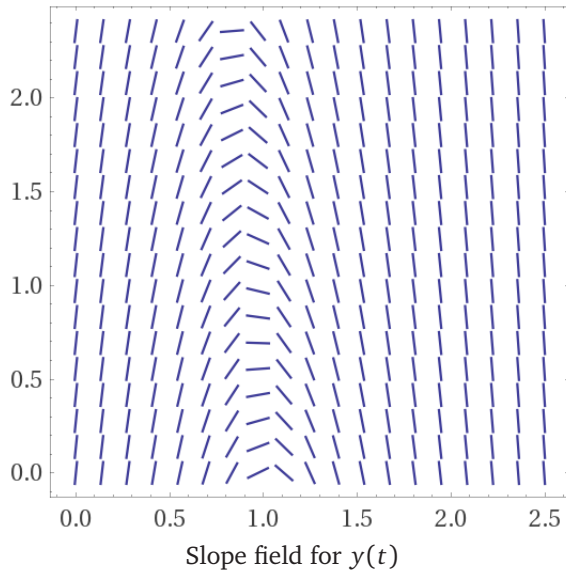

(These slope fields were created using WolframAlpha)

- 14.1 On the slope field, sketch a *possible* solution.
- 14.2 Consider the graph of $y(t)$. Does it form a parabola? Justify your answer.

15 Sketch the slope field for the following differential equations.

15.1 $y' = x$

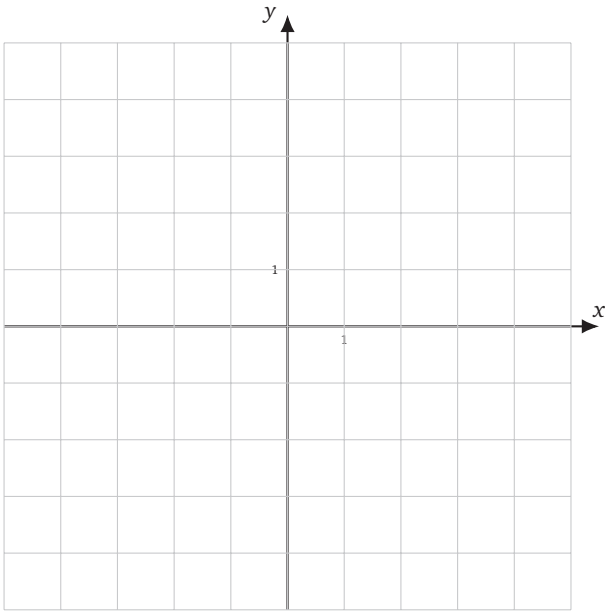

15.2 $y' = y^2$

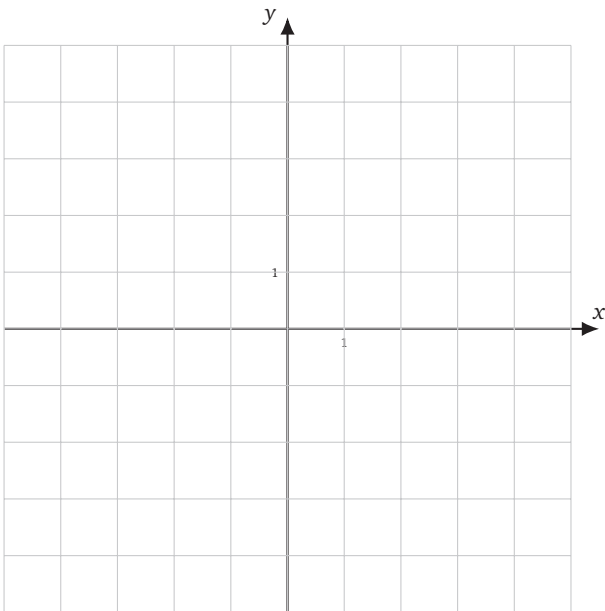

Consider the following slope fields:

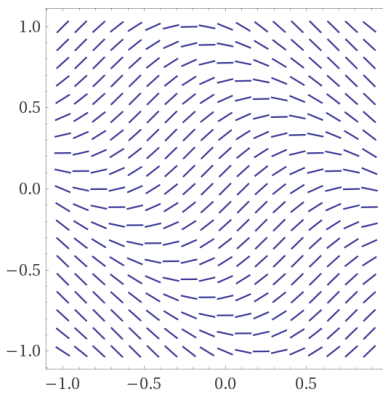

(A)

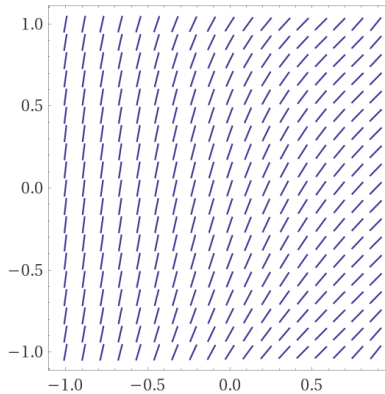

(B)

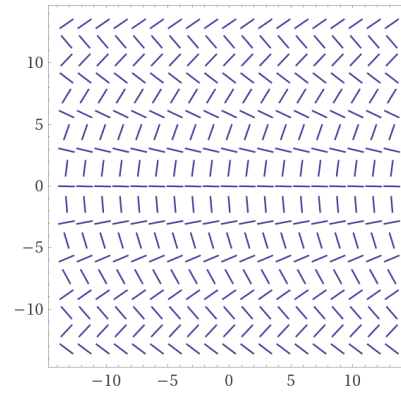

(C)

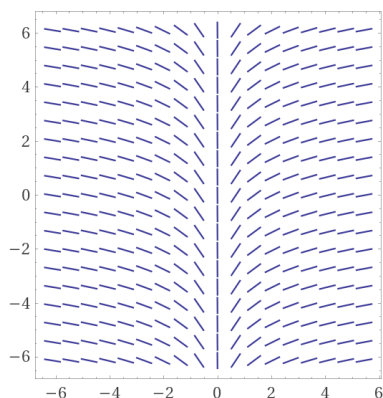

(D)

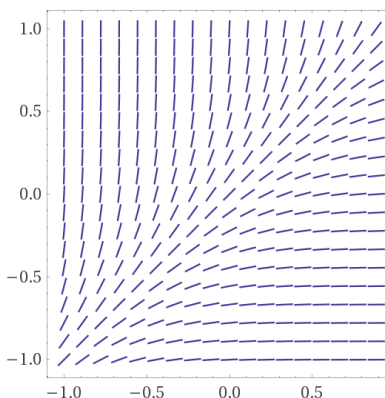

(E)

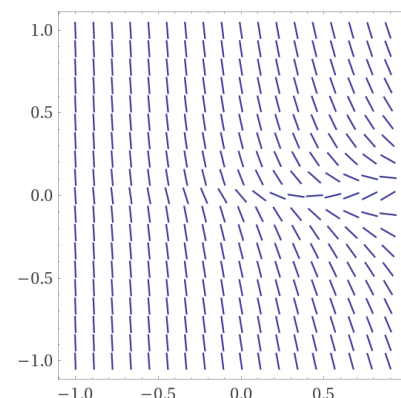

(F)

(These slope fields were created using WolframAlpha)

- | | | | |
|------|---|---------------------------|---|
| 16.1 | Which slope field(s) corresponds to a differential equation of the form | $y' = f(x)$ | ? |
| 16.2 | Which slope field(s) corresponds to a differential equation of the form | $y' = g(y)$ | ? |
| 16.3 | Which slope field(s) corresponds to a differential equation of the form | $y' = h(x + y)$ | ? |
| 16.4 | Which slope field(s) corresponds to a differential equation of the form | $y' = \kappa(x - y)$ | ? |
| 16.5 | Which slope field(s) corresponds to a differential equation of the form | $y' = 1 + (\ell(x, y))^2$ | ? |
| 16.6 | Which slope field(s) corresponds to a differential equation of the form | $y' = 1 - (m(x, y))^2$ | ? |

Approximating Solutions

In this module you will learn

- to approximate the solutions of differential equations

We just learned to sketch a slope field and how to use it to sketch a rough approximation of a solution of a differential equation.

The method of “following the arrows” of a slope field, when formalized mathematically is called **Euler’s Method**.

So let us start with an initial-value problem

$$\begin{cases} y'(t) = f(t, y(t)) \\ y(0) = y_0 \end{cases}$$

The idea is to follow the directions given by the differential equation, so we know that

- $y(0) = y_0$
- $y'(0) = f(0, y_0)$

This means that we have a starting point $(0, y_0)$ and a direction. We still need to decide the distance that we want to follow the arrow:

- smaller distance: more accurate approximation, but will take more calculations
- longer distance: less accurate approximation, but will take fewer calculations

The typical way to decide is to set a parameter Δt , that measures the distance we will travel in the t -axis.

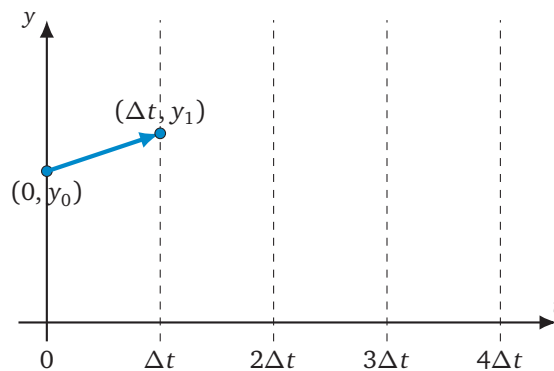

This way we find our second point $(\Delta t, y_1)$ where:

$$\frac{y_1 - y_0}{\Delta t} = \text{slope of the arrow} = f(0, y_0) \Rightarrow y_1 = y_0 + f(0, y_0)\Delta t$$

We continue in this way to find more points (t_i, y_i) :

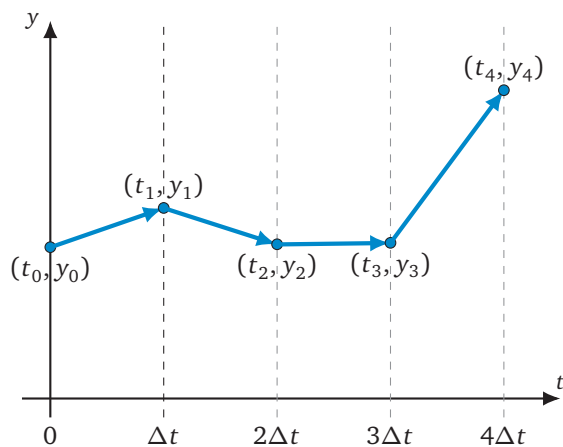

Euler's Method. Let $y'(t) = f(t, y)$ be a first-order differential equation. The *Euler approximation* to the initial value problem

$$\begin{cases} y'(t) = f(t, y) \\ y(t_0) = y_0 \end{cases}$$

with step size Δt is the sequence of points (t_i, y_i) given by (t_0, y_0) if $i = 0$ and

- $t_i = t_{i-1} + \Delta t$

- $y_i = y_{i-1} + f(t_{i-1}, y_{i-1})\Delta t.$

The method used to generate (t_i, y_i) is called *Euler's Method*.

Example. Consider the initial-value problem

$$\begin{cases} y'(t) = \sin(y) + t \\ y(-3) = 2 \end{cases}$$

Then, we can follow Euler's Method with $h = 0.5$ to obtain:

- $y_0 = 2$
- $y_1 = 2 + \frac{1}{2}(\sin(2) - 3) \approx 0.95$
- $y_2 = 0.95 + \frac{1}{2}(\sin(0.95) - 2.5) \approx 0.1$
- $y_3 = 0.1 + \frac{1}{2}(\sin(0.1) - 2) \approx -0.85$

Here is the link to the desmos graph:

- <https://www.desmos.com/calculator/kkgj5jhggd>

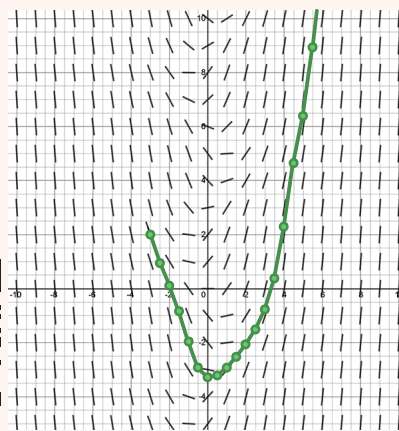

Video.

- <https://youtu.be/q87L9R9v274>
- <https://youtu.be/g3Xw1r7QGOE>





Practice Problems

- 1 For the following initial-value problems, approximate their solution with different values of Δt and compare with their exact solutions.

- (a) $y' = -y + 5 + t$, $y(0) = 4, 5, 6$
 (b) $y' = y + 5 - t$, $y(0) = -4$
 (c) $y' = (t - y) \sin(y)$, $y(0) = -1$
 (d) $y' = \frac{y + 3t}{1 + t^2}$, $y(0) = -1, 1$

Hint. Write a computer program that does the approximation for you.

- 2 Consider the differential equation

$$y' = -\frac{x}{y}.$$

- (a) Sketch a slope field for this differential equation.
 (b) Use Euler's Method to approximate the solution for some values of Δx and for some initial conditions.
 (c) Does Euler Method do a good job approximating the solution?
- 3 In this module, we derived Euler's Method. One of the main steps was obtaining the equation

$$\frac{y_1 - y_0}{\Delta t} = \text{slope of the arrow.}$$

In Euler's Method, we used the slope at the beginning of the arrow. We can derive a new Method where we use the slope at the end of the arrow.

- (a) Find a formula and the algorithm for this new method.
 (b) Use this method with to approximate the solution of $y' = -y + 5 + t$, $y(0) = 4, 5, 6$ and compare the results with your results from question 1.
 (c) Which of these two methods gives a better approximation?
 (d) In your opinion, which of these two methods is better? Why?
- 4 Consider an initial-value problem with solution $y(t)$. If we want to find an approximation for $t \in [0, T]$, we define the error of the approximation $\{y_i^{\Delta t}\}$ by

$$E(\Delta t) = |y(T) - y_N^{\Delta t}|, \quad (\text{E})$$

where $T = N\Delta t$.

- (a) For the initial-value problems from the previous question, study what happens when the value of Δt decreases.

- (b) What do you expect to happen as Δt converges to 0?
 (c) Estimate how fast Euler's method converges. Find a value of p such that

$$E(\Delta t) \leq C(\Delta t)^p,$$

where the constant C changes for each ODE, but doesn't change if you keep the same ODE but change only the value of Δt .

- 5 Using Euler's Method with a step size of $\Delta t = 0.05$, and keeping only three digits throughout your computations, determine the approximations at $T = 0.2, 0.3, 0.4$ for each of the following initial-value problems.

- (a) $y' = -y + 5 + t$, $y(0) = 4$
 (b) $y' = y + 5 - t$, $y(0) = -4$

Compare the results with what you obtained for problem 1. Where do the differences come from?

- 6 Round-off errors become important when the value of N is very large, which happens if we want a very accurate approximation. This means that the actual error (E) of the approximation has two components:

$$E(\Delta t) = f(\Delta t) + g(\Delta t),$$

where

- $\lim_{\Delta t \rightarrow 0^+} f(\Delta t) = 0$ (approximation error)
- $\lim_{\Delta t \rightarrow \infty} f(\Delta t) = \infty$ (approximation error)
- $\lim_{\Delta t \rightarrow 0^+} g(\Delta t) = \infty$ (round-off error)
- $\lim_{\Delta t \rightarrow \infty} g(\Delta t) = 0$ (round-off error)

Answer the following questions and justify your answers based on these ideas.

- (a) Justify why the four limits above make sense.
 (b) Does the approximation converge to the solution as $\Delta t \rightarrow 0$?
 (c) Is there an optimal Δt that gives the best possible approximation?
- 7 The idea of the Euler's method is to approximate the first derivative:

$$y'(t_k) \approx \frac{y_{k+1} - y_k}{\Delta}$$

Similarly, we can approximate the second derivative.

- (a) Use a similar approach to obtain the following approximation:

$$y''(t_k) \approx \frac{y_{k+1} - 2y_k + y_{k-1}}{\Delta^2}.$$

- (b) Use this to create a “Second-Order Euler Method” to approximate the initial-value problem:

$$\begin{cases} \theta''(t) = -\frac{g}{l} \sin(\theta(t)) \\ \theta(0) = \theta_0 \\ \theta'(0) = \theta_1 \end{cases}$$

- 8 Let us try a different type of approximation.
- (a) Give a linear (quadratic) approximation of the angle of the hours hand depending on the minutes hand near 5:20.
 - (b) Use this approximation to estimate the angle of the hours hand at 5:23 and at 5:47.
 - (c) What can you say about the error of the approximation?

17 Consider the initial-value problem

$$\begin{cases} y' = -\sin(x) + \frac{y}{20} \\ y(-10) = 2 \end{cases}$$

The solution satisfies $y(10) = \frac{20\sin(10)+400\cos(10)-2e(-401-10\sin(10)+200\cos(10))}{401} \approx 6.7738406\dots$

- 17.1 Using some software, approximate the solution at $x = 10$ for different values of Δx .
- 17.2 Calculate the error between the solution and the approximation at $x = 10$ for the different values of Δx .
- 17.3 Plot the error. Is it decreasing as Δx decreases? Does it decrease linearly / quadratically / cubically as Δx decreases?

18 Consider the differential equation

$$y' = y - 2.$$

- 18.1 Use Euler's Method to find an approximation of the solution of this differential equation that passes through the point $(0, 3)$.
- 18.2 Find the solution of the differential equation with the same initial condition.
- 18.3 Use Euler's Method to find an approximation of the solution of this differential equation that passes through the point $(0, 1)$.
- 18.4 Find the solution of the differential equation with the same initial condition.
- 18.5 Compare the approximations with the actual solutions. Is there a property of the Euler's Method that you can infer?
- 18.6 Explain in words why the Method satisfies that property.

Modelling with Differential Equations

In this module you will learn

- how to start modelling a physical phenomenon into a differential equation

We started by studying some mathematical modelling in chapter 1. Then, we just used mathematical tools that we learned before.

We now want to focus on mathematical models that arise from physical applications. These will often take the form of one or more differential equations.

The modelling of the situation will develop in a similar way.

Step 1. Defining the problem

As before, we should start by thinking about what our ultimate goal is. Once we settle on a goal, we define it as the function we want to study.

Example.

In this module, we are going to think about the catapult problem from Module 12 (Slope Fields).

A catapult throws a projectile into the air.
Our goal is to track the height (in metres) of the projectile from the ground.

This means that we have a goal: to find the height of the projectile at every moment in time after it is launched.

So we define

- $y(t)$ = height of the projectile, in metres, t seconds after it was launched from the catapult.

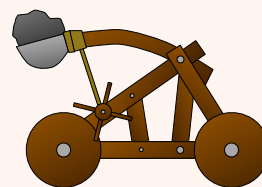

Step 2. Building a mind map

A mind map will help us identify the notions that we want to include in our model.

Example.

In the catapult example, since we decided to study the projectile's height, we need to find everything that affects its height.

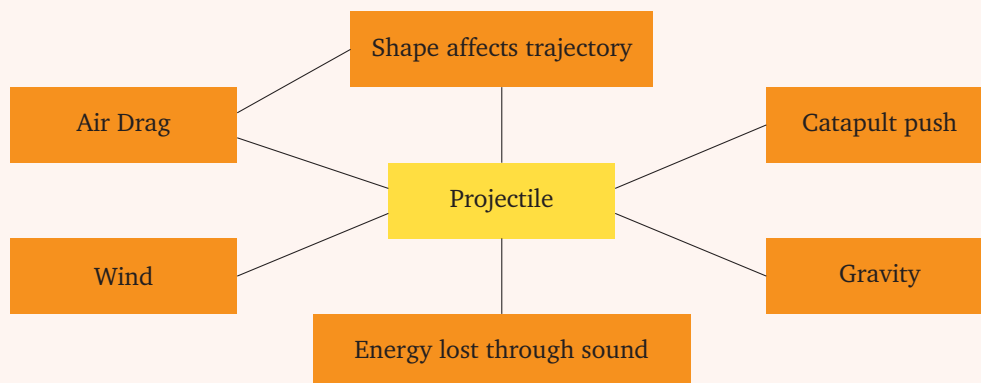

We can include more layers to these topics if we want.

Step 3. Make assumptions

This is a fundamental step in any modelling endeavour. The real world is too complicated, so we make assumptions that simplify our model.

This has two main consequences:

1. It makes our model simpler and easier to study;
2. It creates constraints on our model: it is only valid under certain conditions.

Example.

Let us discuss the topics included in the mind map above:

- Catapult Push – the catapult pushes on the projectile for a small period of time when $t < 0$. If we are considering only $t \geq 0$, then this will likely provide us with some starting conditions for the projectile
- Gravity – The height of the projectile is affected by gravity. We have a choice to make:
 - assume that the Earth is flat and gravity is constantly accelerating the projectile downwards;
 - assume that the Earth is spherical and gravity is constantly accelerating the projectile towards the centre of the Earth;
 - assume that the Earth is spherical and gravity is a force accelerating the projectile towards the centre of the Earth with a magnitude that decreases with the square of the distance to the centre of the Earth
 - or other more complicated and more accurate models.
- Air Drag – air is making it hard for the projectile to move forward. We have another choice to make:
 - assume that the air drag is a force that accelerates the projectile in the direction opposite to its movement and with magnitude proportional to its speed;
 - assume that the air drag is a force that accelerates the projectile in the direction opposite to its movement and with magnitude proportional to the square of its speed;
 - or other more complicated and more accurate models.

I will leave it to you to think about the remaining three topics in the mind map.

We now need to make a decision about what to assume.

To keep this model simple, let us assume the following:

1. The projectile's height will stay within a small range: $y(t) \in [0, 100]$. Is this reasonable for a catapult? This means that we can consider the first of the gravitational models above: define gravitational acceleration as a constant $-g$.
2. The projectile will not move very fast, so we can approximate the air drag to be directly proportional to the speed: define air drag acceleration as $\pm\gamma v$, where $\gamma > 0$ is a constant that depends on the projectile and v is the velocity of the projectile. Which sign should we have?
3. Again, the projectile will not move very fast, so we can approximate the air drag to use only the vertical speed of the projectile: define air drag acceleration as $\pm\gamma v_y$, where $\gamma > 0$ is a constant that depends on the projectile and v_y is the vertical velocity of the projectile. Which sign should we have?
4. The shape of the projectile will affect air drag in the form of the constant $\gamma > 0$.
5. Assume that for a medieval catapult (as in the drawing above), the other components are negligible.

We come out of this step with some conditions for the validity of our model and some new constants and terms to use in our model.

Step 4. Construct a model

This is the part where we put together the last three steps into one (or a system of) differential equations. This should not be a difficult part if the last three steps were completed carefully.

Example.

Summary of Steps 1–3:

- **Goal:** study $y(t)$ = height of a projectile in metres, t seconds after being released from a catapult
- **Forces:**
 - Gravity: constant acceleration $-g$
 - Air Drag: acceleration $\pm \gamma y'(t)$
- **Conditions:**
 - $y(t) \in [0, 100]$
 - Air drag should really be quadratic, but in this example we will consider this as an academic case.

So the model we end up is:

$$F_y = \begin{matrix} \text{vertical component} \\ \text{of force} \end{matrix} = -g \pm \gamma y'.$$

Now we bring a little bit of a Physics class into here: Newton's 2nd Law states that $F = ma$, so we obtain the model

$$m y''(t) = -g \pm \gamma y'(t).$$

Step 5. Model Assessment

We just found a differential equation (model) for our situation. It is now time to test it to make sure that it behaves correctly.

For this step, we need to obtain a solution of the differential equation, either by solving it mathematically and finding a formula for the solution (see module 21), or by approximating the solution numerically (see module 16).

Then we need to check the quality of the differential equation in one of several ways:

- We can test it **empirically**: make an experiment and compare the results of the experiment with the results of the model
- We can test it **mathematically**: change the parameters and the initial conditions to make sure that we know how the model should behave and test some qualitative aspects of the model

Important. Even if the model passes all the tests, it might still not be correct.

Also, if it fails one test, it might mean that the model is incorrect, or that it has some limitations that are more subtle and we hadn't thought about them.

Example. We have found the following model:

- $y(t)$ = height of a projectile in metres, t seconds after being released from a catapult
- It satisfies:

$$m y''(t) = -g + \gamma y'(t).$$

(note that I chose the + sign for the air drag component)

- Constraints:
 - $y(t) \in [0, 100]$;
 - $\gamma > 0$ is the drag constant: more air drag for larger values of γ ;

This differential equation tells us what the second derivative, $y''(t)$, of $y(t)$ is, given the first derivative $y'(t)$. This means that to start solving the problem, we need to know what the initial values for $y'(t)$ and $y(t)$ are.

Need to know the starting conditions:

- $y(t_0) = y_0$;

- $y'(t_0) = v_0$.

For this example, consider a situation where:

- $g, \gamma > 0$ can take any value.

- $y(0) = 0$;

- $y'(0) = g/\gamma > 0$;

The projectile is being catapulted from the ground with a positive velocity, so we expect it to go up for a while and then come back down to the ground.

What happens is

$$y''(0) = -g + \gamma y'(0) = 0,$$

so the initial acceleration is 0, which means that the velocity is not changing.

The result is a function with constant velocity equal to its initial velocity:

- $y(t) = \frac{g}{\gamma} t$.

This means that the height of the projectile keeps increasing, so the **projectile never falls back to the ground!**

This means that there is a problem with our differential equation:

- Is the model incorrect?

- Is there a limitation on the initial velocity that we were not aware of?

We must check our process again and correct it.

Step 6. Putting it all together in a report

We're not going to elaborate much on this step. For more on the subject, please check Module 8.

Video.

- <https://youtu.be/njg8xwMviGQ>

- <https://youtu.be/nKDsJB8iwb0>

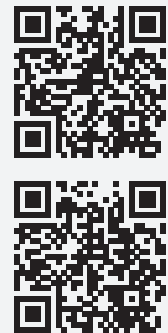

Practice Problems

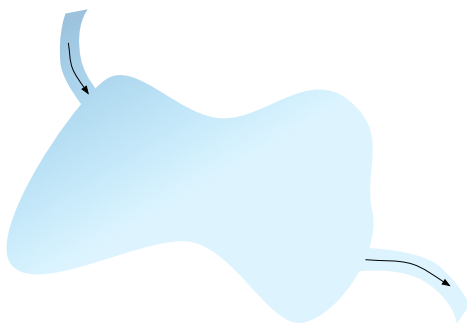

- 1 Model the pollution in a lake where water flows in and out at the same rate and incoming water is polluted with $2 + \sin(2t)$ kg/L of pollutant, where t is measured in years.
- 2 Construct a model for a population with a rate of

growth proportional to its current size.

- 3 Find a model for a population that grows proportionally to its current size but with a variable proportion constant. This variable proportion constant should guarantee the following properties for the population:
 - If the population is too large, then it should decrease;
 - If the population is small, then it should increase.
- 4 Improve the previous model by considering also a **survivability threshold**: if the population is below this value, it should decrease and eventually become extinct.
- 5 Consider two competing populations, like cheetahs ($c(t)$) and lions ($\ell(t)$): two populations that do not hunt each other, but compete for the same food (prey).

Create a model for these two populations that captures how the competition for food affects them.

Hint. It might be helpful to think about how one population would grow in the absence of the other; and how one population is affected by the competition of the other.

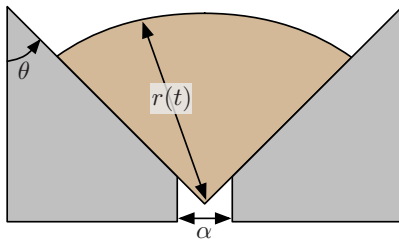
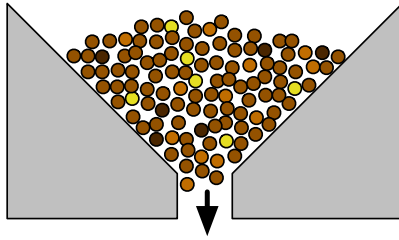

6 People are in a stadium watching cricket match. When the match is over, people leave the stadium.

(a) Model the way people leave the stadium.

To help you with this task, use the fact that in this situation, people behave like a fluid according to Torricelli's Law:

The area of the region occupied by the fans decreases proportionally to the square root of the radius and also proportionally to the size of the exit.

(b) How do the parameters θ and α affect the total time it will take for the stadium to empty?

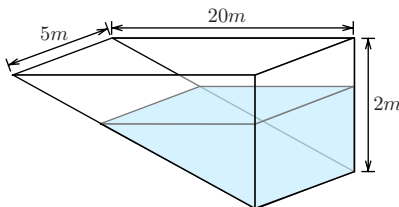

7 Consider the pool in the figure. The goal is to track the amount of chlorine in the water for one Summer month. At the beginning of the month, the pool is full and contains 150g of chlorine uniformly mixed in the water. Consider evaporation and rain. To make the model simpler, assume that water evaporates with the chlorine.

8 Model an iceberg floating in the ocean. How much of the iceberg is underwater?

9 Model the average temperature in a room.

10 After solving the core exercise 20 below, we find a property of this model.

(a) The constants g and L (length of the string) appear only has $\frac{g}{L}$. What does this imply?

(b) We are sending a mission to the Moon and we need to know how a 1m long pendulum behaves on the Moon. To test it, we need to build on Earth a pendulum that behaves in the same way. How long should the length of the string be on Earth?

11 After solving the core exercise 20 below, construct a model for the same problem considering string tension.

(a) Show that you obtain the same model that you get while disregarding tension.

(b) Explain why this makes sense.

12 The alien world of Robotron is inhabited by billions of tiny nanobots. These nanobots all share a common source of power, and their speed is directly proportional to the total amount of energy shared among all the nanobots.

One day the nanobots decide to beam their energy into space. They all form lines, march to the edge of their colony, and send a tiny portion of their shared energy into space. Since the nanobots are very polite, after an individual nanobot has sent its energy into space, it moves aside and lets the next nanobot take a turn.

(a) Suppose the nanobots live in a tube with an opening at only one end. Come up with a differential equation to model the amount of energy left in the nanobot colony over time.

(b) How does your model change if the nanobots live in a disk where energy can be launched from anywhere on the perimeter? What about a sphere?

(c) Newton's law of cooling states that the rate of change of temperature of an object is proportional to the difference between the object's temperature and the ambient (outside) temperature. Does this law relate to your model for the nanobots? If so, how?



13 An ant queen, known affectionately as Aunty Ant, is commissioning a construction assessment for a new tunnel. Aunty Ant's worker ants only know one way to construct a tunnel: they grab some dirt in their pincers, walk the dirt out of the tunnel, deposit it, and then return to grab more dirt.

Prepare a report which uses differential equations to address the following construction scenarios. Include a description of how you modelled the scenario and a graph of tunnel-length vs. worktime. Also make sure to define any variables and constants you are using.

(a) One tireless worker is assigned dig the tunnel. The worker walks the same speed whether she is carrying dirt or not.

(b) One tireless worker is assigned to dig the tunnel, but she can walk twice as fast when she is not carrying dirt as when she is carrying dirt.

- (c) Aunty Ant really wants the tunnel to progress linearly after the first day of construction (that is, the graph of tunnel-depth vs. time after the first day should be a straight line). She will give you full control over how many workers are devoted to the tunnel at any given time.
- (d) (Optional) A single ant is assigned to dig the tunnel, but she gets fatigued the farther she walks. Her speed after walking a total distance of k units is $1/k$.

A pendulum is swinging side to side. We want to model its movement.

- 20.1 Define the problem. Which function(s) do we want to find in the end?
- 20.2 Build a mind map.
- 20.3 Make assumptions. Remember to use your mind map to help structure the problem.
- 20.4 Construct a model. You should end up with one (or more) differential equations.

Remember that there are some Physics principles that can help you (e.g. Newton's 2nd Law, Conservation of Energy, Linear Momentum, and Angular Momentum, Rate of Change is Rate in – Rate out).

- 20.5 Assess your model:
 - (a) Find one test that your model passes.
 - (b) Find one test that your model fails.

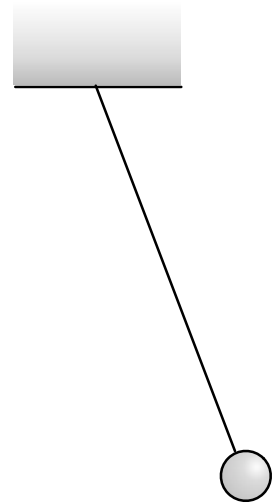

-
- 21 Model the spreading of a rumour through the students of a school.
Hint. Start with a simple model and then include more details.

Solvable Types of ODEs

In this module you will learn

- to identify specific types of differential equations that can be solved rigorously
- how to solve these types of differential equations

We just learned how to model a situation and end up with a differential equation. We will now focus on solving differential equations.

There are a few different techniques that depend on the differential equation.

12.1. Separable Differential Equations

Separable ODE. A differential equation is called *separable* if it has the form

$$g(y)y'(t) = h(t),$$

that is if we can separate all the y 's into the left-hand side and all the t 's into the right-hand side of the equation. Observe that the y 's on the left hand side must all be multiplied by $y'(t)$.

Method of solution. The idea to solve this type of DEs is simple:

1. Integrate both sides with respect to t :

$$\int g(y)y'(t) dt = \int h(t) dt$$

2. Change variables on the left-hand side to $u = y(t)$, so $du = y'(t)dt$ and we get

$$\int g(u) du = \int h(t) dt.$$

3. Solve both integrals and we obtain a solution, usually in implicit form:

$$G(u) = H(t) + C.$$

4. To finish, recall that $u = y(t)$, so we obtain

$$G(y(t)) = H(t) + C.$$

Important. Observe that the solution is given in implicit form. In general, when using this technique, the solution $y(t)$ will be given in implicit form, so there is still some work ahead to find an explicit formula for $y(t)$.

A simplified method of solution is the following:

- Start with the differential equation

$$g(y) \frac{dy}{dt} = h(t).$$

- “Move the dt to the other side”:

$$g(y)dy = h(t)dt.$$

- Integrate both sides

$$\int g(y)dy = \int h(t)dt.$$

Example. The shape $y(x)$ of a free falling chain under its own weight, called a catenary, satisfies the differential equation:

$$y''(x) = \frac{1}{a} \sqrt{1 + (y'(x))^2}.$$

It doesn't seem to be a *separable equation*, but if we can define $z(x) = y'(x)$, which satisfies

$$z'(x) = \frac{1}{a} \sqrt{1 + (z(x))^2} \quad \Leftrightarrow \quad \frac{1}{\sqrt{1 + (z(x))^2}} z'(x) = \frac{1}{a}.$$

This is now in the form of a *separable ODE*.

We can solve it using the method described above: we need to solve

$$\int \frac{1}{\sqrt{1 + z^2}} dz = \int \frac{1}{a} dx = \frac{x}{a} + C_1$$

The integral on the left can be solved using a hyperbolic substitution $z = \sinh u$:

$$\int \frac{1}{\sqrt{1 + z^2}} dz = \int 1 du = u = \operatorname{arcsinh} z.$$

This means that the solution satisfies

$$\operatorname{arcsinh} z = \frac{x}{a} + C_1 \quad \Leftrightarrow \quad z = \sinh\left(\frac{x}{a} + C_1\right).$$

Now recall that $z(x) = y'(x)$, so we need to integrate $z(x)$ to obtain the catenary curve $y(x)$:

$$y(x) = \int z(x) dx = a \cosh\left(\frac{x}{a} + C_1\right) + C_2.$$

To find C_1 and C_2 , we use the fact that $y'(0) = 0$:

$$y(x) = a \cosh \frac{x}{a} + C_2.$$

(the constant C_2 moves the curve up or down, so it doesn't change the shape).

Video.

■ <https://youtu.be/txtFH89HwOA>

■ https://youtu.be/8xG_Xg6X2MQ

■ <https://youtu.be/ZE1Agfchr28>



12.2. First-Order Linear Differential Equations

First-Order Linear ODE. A differential equation is called *first-order linear* if it has the form

$$y'(t) + p(t)y(t) = f(t).$$

The idea to solve this type of DEs is to transform it into the result of a product rule.

Example. Consider the following *first-order linear ODE*

$$t^2 \frac{dy}{dt} + 2ty = \sin t.$$

Observe that the left-hand side of the DE is the result of the product rule:

$$\frac{d}{dt} [t^2 y] = \sin t.$$

So we can integrate both sides with respect to t to obtain

$$t^2 y = -\cos t + C \quad \Leftrightarrow \quad y = -\frac{\cos t}{t^2} + \frac{C}{t^2}.$$

Now let us look at another example, where the left-hand side of the ODE is not in the form of the result of a product rule, but can be transformed into one.

Example. Consider the *first-order linear ODE*

$$\frac{dy}{dt} + \frac{1}{2}y = \frac{1}{3}e^{\frac{t}{3}}. \quad (*)$$

Again, the “trick” is to look at this equation and realize that the left-hand side can look like the result of the product rule. It’s not obvious that this can be done (yet!), but if we multiply the whole ODE by the function

$$e^{\frac{t}{2}},$$

then we obtain

$$e^{\frac{t}{2}} \frac{dy}{dt} + \frac{1}{2}e^{\frac{t}{2}}y = \frac{1}{3}e^{\frac{t}{2}}e^{\frac{t}{3}}$$

and now the left-hand side is the result of a product rule

$$\frac{d}{dt} [e^{\frac{t}{2}}y] = \frac{1}{3}e^{\frac{5}{6}t}.$$

We integrate both sides to obtain

$$e^{\frac{t}{2}}y = \frac{1}{3} \frac{6}{5} e^{\frac{5}{6}t} + c$$

thus

$$y = \frac{2}{5}e^{\frac{t}{3}} + ce^{-\frac{t}{2}}.$$

This last example required us to come up with a function to multiply the ODE so that it becomes of the right form: with a left-hand side that is the result of the product rule.

This function is called the **integrating factor**.

Let us now see how we can find this function in more detail.

Example. Consider the same ODE (*):

$$\frac{dy}{dt} + \frac{1}{2}y = \frac{1}{3}e^{\frac{t}{3}}. \quad (*)$$

So we multiply both sides of the equation with an unknown function $\mu(t)$, called the **integrating factor**:

$$\mu(t) \frac{dy}{dt} + \frac{1}{2} \mu(t) y = \frac{1}{3} \mu(t) e^{\frac{t}{2}}.$$

And we find which $\mu(t)$ makes the left-hand side equal to the product rule:

$$\frac{d}{dt} [\mu(t)y] = \mu(t) \frac{dy}{dt} + \frac{d\mu(t)}{dt} y,$$

and this needs to equal the left-hand side:

$$\mu(t) \frac{dy}{dt} + \frac{d\mu(t)}{dt} y = \mu(t) \frac{dy}{dt} + \frac{1}{2} \mu(t) y \quad \Leftrightarrow \quad \mu'(t) = \frac{1}{2} \mu(t).$$

We now need to solve this differential equation for $\mu(t)$. Fortunately, this is a **separable ODE**:

$$\begin{aligned} \mu'(t) = \frac{1}{2} \mu(t) &\Leftrightarrow \frac{\mu'(t)}{\mu(t)} = \frac{1}{2} \\ &\Leftrightarrow \ln |\mu(t)| = \frac{t}{2} + A \\ &\Leftrightarrow \mu(t) = a e^{\frac{t}{2}}, \end{aligned}$$

where $a = e^A$.

We say that the function $\mu(t) = e^{\frac{t}{2}}$ is an **integrating factor** for the equation (*). Observe that we chose $a = 1$ ($A = 0$), because we only need **one** function $\mu(t)$ that satisfies our condition $\mu' = \frac{1}{2} \mu$, we don't need to find all possible solutions.

After finding the integrating factor $\mu(t)$, the rest of the solution is the same as in the previous example.

Now that we have a good idea of the method needed to solve these ODEs, let us tackle the general equation.

Method of solution. This method is also known as the **Method of the Integrating Factor**.

1. Multiply both sides by $\mu(t)$, the integrating factor:

$$\mu(t) \frac{dy}{dt} + p(t) \mu(t) y = \mu(t) g(t).$$

Note that we don't know what this function is yet. So it is just a placeholder for a function we will find next.

2. Find function $\mu(t)$ which satisfies

$$\mu'(t) = p(t) \mu(t).$$

This is a **separable ODE**, so we can solve it:

$$\mu(t) = A e^{\int p(t) dt}.$$

We only need one function $\mu(t)$, not the general one, so we take $A = 1$ to get

$$\mu(t) = e^{\int p(t) dt}.$$

3. Observe that $\mu(t)$ satisfies

$$\mu(t) p(t) = \mu'(t),$$

so we use this in the equation:

$$\frac{d}{dt} [\mu(t)y] = \mu(t) g(t).$$

4. Integrate the equation:

$$\mu(t)y = \int \mu(t) g(t) dt + c,$$

which means that the solution is

$$y = \frac{1}{\mu(t)} \left[\int \mu(t)g(t) dt + c \right],$$

where

$$\mu(t) = e^{\int p(t) dt}.$$

Important. Observe that the solution is given in explicit form. This is always the case with this type of ODEs.

Also, be careful to add the integration constant as soon as you integrate, so that in the end you will have a term $\frac{c}{\mu(t)}$.

Video.

■ https://youtu.be/ezhi3E_bdvk

■ <https://youtu.be/VdD26Iy4Bkk>

■ <https://youtu.be/GIp0cHNK7eQ>



Practice Problems

- Solve the differential equation $\ln(t)y' + \frac{1}{t}y = 3$.
- Decide whether the following differential equations are separable, first-order linear, both, or neither. If they are of one type, solve it.
 - $(t^2 + 4)y'(t) = \frac{2t}{y^2}$
 - $\frac{1}{t^2}y'(t) = 2$
 - $\frac{dy}{dx} = \sqrt{y}(x + 1)^2$
 - $y'(t) = t + y$
 - $y'(t) = t + y^2$
 - $y'(t) = \frac{t}{y}$
 - $y'(t) = -\frac{1}{t}y$
 - $y'(t) = 1 - 4t - \frac{5}{t}y$
 - $y'(t) = 5t - 2ty$
 - $y'(t) = 2 + \cos^2(y)$
 - $e^{-t}y'(t) - e^{-t}y = 3e^{2t}$

- Decide whether the following statements are true or false. Give an explanation or a counterexample.

- There are differential equations that are both separable and first-order linear.
- There are differential equations that are separable, but are not first-order linear.
- There are differential equations that are first-order linear, but not separable.
- There are first-order differential equations that are neither separable nor linear.
- All first-order linear differential equations have solutions defined in the whole real line.

- Consider the differential equation

$$y' - \frac{y}{2(x+4)} = \frac{1}{2(x+4)}$$

- Find the general solution.
 - Find the solution with initial condition $y(0) = -5$.
 - What is the domain of the previous solution?
 - Find the solution with initial condition $y(-5) = -5$.
- Even though the following differential equation is not linear, find its general solution:

$$2 \ln(x)e^{2y}y'(x) + \frac{e^{2y}}{x} = 4x^3.$$

6 You are consulting for the police on Bernardo's murder.

These are the facts about the murder:

- (a) The body was found at 9am;
- (b) The body was found with the temperature of 25°C (average temperature is 37°C);
- (c) The victim measured 185cm tall (average is 176cm) and weighed 75kg (average is 80kg);
- (d) The body was found in his living room, which measured 25m^2 , and the thermostat was set to 22°C ;

There are five suspects that were with the victim the previous night:

- Pedro (height 179cm, weight 82kg) met with the victim at 6pm-8pm;
- Jason (height 176cm, weight 65kg) met with the victim at 8pm-10pm;
- Mihnea (height 183, 83 kg) met with the victim at 10pm-midnight;
- Paco (height 172cm, weight 79kg) met with the victim at midnight-2am;
- Ricardo (height 178cm, weight 76kg) met with the victim at 2am-4am.

Who killed Bernardo? (Your answer should stand in a court of law!)

22 Decide whether the following differential equations are separable, first-order linear, both, or neither. If they are of one of the solvable types, solve it.

22.1 $\theta''(t) = \frac{g}{L} \sin(\theta(t))$

22.2 $P'(t) = rP(t) \left(1 - \frac{P(t)}{K}\right)$

22.3 $v'(t) = -g - \frac{\gamma}{m}v(t)$

22.4 $y'(t) = -gt - \frac{g}{m}y(t) + 10$

23 23.1 Calculate $(\sin(x)f(x))'$.

23.2 Find the general solution of

$$\sin(x)y' + \cos(x)y = \sqrt{x}.$$

23.3 What is the integrating factor for the differential equation

$$y' + \frac{\cos(x)}{\sin(x)}y = \frac{\sqrt{x}}{\sin(x)}$$

Properties of Differential Equations

In this module you will learn

- to find some properties of solutions without the need to find a solution or approximating it
- existence and uniqueness of solution theorems

Until now we studied problems where there was one unique solution. Is this true for every problem?

- There are DEs with no solutions, e.g. $(y')^2 = -1$ or $\sin(y') = 2$.

So if a problem has a solution, is it always unique?

- This is also not true. For example: $ty' = 2y$ with $y(0) = 0$.

Check that

$$\begin{aligned}y = 0 & \quad \text{is a solution} \\ y = t^2 & \quad \text{is also a solution}\end{aligned}$$

It is important (not just to mathematicians) to know whether a problem has solutions or not before trying to solve it. It is also important to know whether there is one unique solution or multiple solutions.

So for **linear differential equations** we have the following theorem.

Theorem. Let p and g be continuous functions in an open interval $I = (a, b)$ containing the point t_0 . Then there exists a unique function $y = \phi(t)$ that satisfies

$$\begin{aligned}y' + p(t)y &= g(t) \quad \text{for each } t \in I, \\ y(t_0) &= y_0,\end{aligned}$$

for any $y_0 \in \mathbb{R}$.

Example. Consider the initial-value problem

$$\begin{cases} y' + \frac{1}{\sin(t)}y = e^t \\ y(1) = 2 \end{cases}$$

We can see that

- $p(t) = \frac{1}{\sin(t)}$, which is continuous for $t \in (0, \pi)$ and $t_0 = 1$ is included in this interval;
- $g(t) = e^t$ is continuous for all values of t .

So we can conclude, from the Theorem, that there is a unique solution $y(t)$ defined for $t \in (0, \pi)$.

Example. Above, we saw that $ty' = 2y$ has more than one solution. We can now see that this Theorem doesn't apply to this differential equation.

First, we need to rewrite the differential equation in the same form of the Theorem:

$$y' - \frac{2}{t}y = 0.$$

Now we observe that $p(t) = -\frac{2}{t}$ is not continuous at 0.

Example. The equation $y' = \frac{2}{3\sqrt[3]{x}}$ with the condition $y(0) = 0$ has a unique solution:

$$y = x^{\frac{2}{3}}.$$

So even though $g(t) = \frac{2}{3\sqrt[3]{x}}$ is not continuous at 0, the ODE still has a unique solution.

What can you conclude from the last two examples?

The previous Theorem is very restrictive – it only applies to some very particular differential equations. Below, we state another Theorem that applies to a much broader range of differential equations.

Theorem. Let the functions $f(t, y)$ and $\frac{\partial f}{\partial y}$ be continuous in some rectangle $|t - t_0| \leq a$ and $|y - y_0| \leq b$ for $a, b > 0$.

Then, in some interval $(t_0 - h, t_0 + h)$, there is a unique solution $y = \phi(t)$ of the IVP

$$\begin{aligned} y' &= f(t, y) \\ y(t_0) &= y_0. \end{aligned}$$

Partial derivative. Consider a function $f(t, y)$. Then its *partial derivative with respect to y* at the point (t_0, y_0) , denoted by $\frac{\partial f}{\partial y}(t_0, y_0)$ is $g'(y_0)$, the derivative of the function $g(y) = f(t_0, y)$ at the point y_0 . Roughly, assume that the variable $t = t_0$ is a fixed number and take the derivative on the variable y .

In fact, the condition that $f(t, y)$ be continuous is sufficient to conclude that the solution exists. The condition that $\frac{\partial f}{\partial y}$ be continuous is required to be able to conclude the uniqueness of the solution.

You should spend some time comparing these two Theorems.

Observe that the last Theorem gives a much weaker result when the differential equation is linear.

Example. Consider the IVP

$$\begin{cases} y' = y^2 \\ y(0) = 3. \end{cases}$$

This problem is nonlinear, so we need to use the second Theorem. To apply, compute

$$\begin{aligned} f(x, y) &= y^2 \\ \frac{\partial f}{\partial y}(x, y) &= 2y, \end{aligned}$$

which are continuous for all $x, y \in \mathbb{R}$.

The previous Theorem guarantees that a solution exists and is unique in some interval around $x = 0$. Even though the rectangle spans the whole space of x and y , it doesn't mean that the solution exists for all x .

In fact, this is a separable ODE, so we can find its solution:

$$y(x) = \frac{1}{\frac{1}{3} - x},$$

which is defined only for $x < \frac{1}{3}$.

This kind of Theorems are called **Existence and Uniqueness Theorems**.

Video.

■ <https://youtu.be/53BPf9JrFcU>





Practice Problems

1 For the following initial-value problems, answer the following questions:

- (i) Is there a unique solution?
 - (ii) Without solving, what is its domain?
- (a) $y' + y = t$ with $y(0) = 0$.
 - (b) $y' + \frac{1}{e^t}y = t$ with $y(0) = 0$.
 - (c) $y' + \frac{1}{e^t - 2}y = t$ with $y(0) = 0$.
 - (d) $y' + \ln(t)y = t$ with $y(e) = 1$.
 - (e) $y' + \frac{1}{1 + t^2}y = \tan(t)$ with $y(0) = 0$.
 - (f) $y' + \frac{1}{1 + t^2}y = \tan(2t)$ with $y(\pi) = 0$.
 - (g) $y' = \frac{1}{1 + \sin(t)}y - \tan(t)$ with $y(0) = 0$.
 - (h) $y' = \frac{1}{1 + \sin(t)}y - \tan(t)$ with $y(t_0) = 0$.
 - (i) $y' = \frac{1}{1 + \sin(t)}y^2 - \tan(t)$ with $y(t_0) = 0$.
 - (j) $y' + \ln(y) = t$ with $y(e) = 1$.
 - (k) $y' = \frac{ty}{1 + y}$ with $y(0) = 0$.
 - (l) $(t + y^2)y' = ty$ with $y(-1) = 1$.
 - (m) $y' = \frac{t \sin(y)}{y}$ with $y(1) = 0$.

2 Consider the problem

$$y' + p(t)y = g(t) \quad \text{with} \quad y(t_0) = y_0,$$

where $p(t)$ and $g(t)$ are graphed below

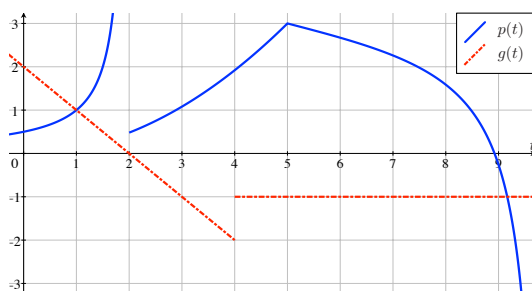

- (a) Is there a unique solution satisfying $y(3) = 2$? If so, what is its domain?
- (b) Is there a unique solution satisfying $y(t_0) = -1$ for which values of t_0 ? If so, what is the domain of these solutions?

3 Consider the problem

$$y' = f(t, y)$$

where $f(t, y)$ and $\frac{\partial f}{\partial y}(t, y)$ are continuous for all t, y .

■ Assume that $y = \frac{1}{t}$ is a solution for $t > 0$

■ Assume that $y = -e^{-t}$ is a solution for all t

Let $y = \phi(t)$ be the solution of this ODE with the initial condition $y(1) = \frac{1}{2}$.

Calculate $\lim_{t \rightarrow +\infty} y(t)$.

4 Consider the initial-value problem:

$$\begin{cases} y' = \ln(t+2)y + \frac{1}{t-3} \\ y(0) = 0 \end{cases}$$

- (a) Is this ODE linear or nonlinear?
 - (b) Show that this problem has a unique solution.
 - (c) Use the Existence and Uniqueness Theorem for **Linear** ODEs. What is the domain of the solution?
 - (d) Use the Existence and Uniqueness Theorem for **Nonlinear** ODEs. What is the domain of the solution?
 - (e) Compare both Theorems.
- 5 Consider the initial-value problem:

$$\begin{cases} y' = \ln(t+2)y + \frac{1}{t-3} \\ y(0) = 0 \end{cases}$$

- (a) State the conditions to be able to apply the Existence and Uniqueness Theorem for **Linear** ODEs.
 - (b) State the conditions to be able to apply the Existence and Uniqueness Theorem for **Nonlinear** ODEs. Simplify the conditions.
 - (c) Compare the conditions of both theorems.
- 6 Consider the initial-value problem:

$$\begin{cases} y' + p(t)y = g(t) \\ y(0) = 0 \end{cases}$$

- (a) State the conditions to be able to apply the Existence and Uniqueness Theorem for **Linear** ODEs.
- (b) State the conditions to be able to apply the Existence and Uniqueness Theorem for **Nonlinear** ODEs. Simplify the conditions.
- (c) Compare the conditions of both theorems.

Consider the example in the video:

$$\begin{cases} x \frac{dy}{dx} = y \\ y(0) = b \end{cases}$$

Without solving, but only according to the Existence and Uniqueness Theorem, what can we conclude?

- (a) We can conclude that there is a unique solution.
- (b) We can conclude that if $b = 0$ there are many solutions, but if $b \neq 0$, then there are no solutions.
- (c) We can conclude that there are many solutions.
- (d) We can conclude that there are no solutions.
- (e) We can't conclude anything.

For the following initial-value problems, answer the following questions:

- (a) Is there a unique solution?
- (b) Without solving, what is its domain?

25.1 $y' = t + \frac{y}{t-\pi}$ with $y(1) = 1$

25.2 $y' = t + \sqrt{y-\pi}$ with $y(1) = 1$

25.3 $y' = \sqrt{4-(t^2+y^2)}$ with $y(1) = 1$

26

Consider a differential equation $y' = f(t, y)$ where

- $f(t, y)$ is continuous for all $t, y \in \mathbb{R}$;
- $\frac{\partial f}{\partial y}(t, y)$ is continuous for all $t \in \mathbb{R}, y > 0$.

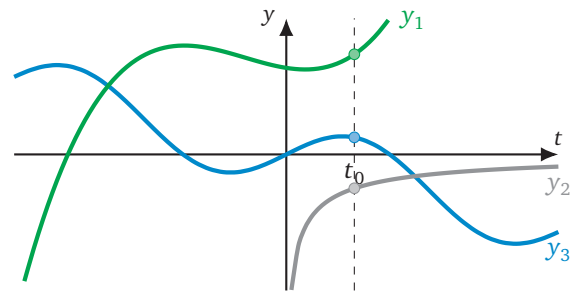

- 26.1 Can **green y1** and **blue y3** be two solutions of the same differential equation above with two different initial conditions? Why?
- 26.2 Can **green y1** and **gray y2** be two solutions of the same differential equation above with two different initial conditions? Why?
- 26.3 Can **gray y2** and **blue y3** be two solutions of the same differential equation above with two different initial conditions? Why?
- 26.4 Based on the answers to the three parts above, write a Corollary to the Existence and Uniqueness Theorems.

$$\begin{cases} y' = -\frac{x}{y} \\ y(\frac{1}{2}) = \frac{\sqrt{3}}{2}. \end{cases}$$

has the solutions

$$y_1(x) = \cos(\arcsin(x)) \quad \text{and} \quad y_2(x) = \sqrt{1-x^2} \quad .$$

- 27.1 Does the problem satisfy the conditions of one of the Existence and Uniqueness Theorems?
27.2 What can you conclude?

Hint. “When you have eliminated the impossible, whatever remains, however improbable, must be the truth.” – Sherlock Holmes

Autonomous Differential Equations

In this module you will learn

- what is an autonomous differential equation
- how to obtain some properties of solutions of autonomous differential equations without solving them

In this module, we focus on another type of differential equations. The ultimate goal of this module is to learn that with some creativity and observation of the differential equation, it is possible to study solutions without actually solving them.

We start by defining autonomous equations.

Autonomous differential equations. A first-order DE is called *autonomous* if it has the form

$$y' = f(y).$$

These are basically ODEs where the rate of change does not depend on time, meaning that the nature of the ODE always stays the same.

Observe that autonomous ODEs are also Separable ODEs.

So let us look at an autonomous ODE and think what happens when $f(y_0) = 0$?

Then if the solution is unique (what are the conditions that will guarantee that?) and if $y(t_0) = y_0$, that means that

$$y'(t_0) = f(y_0) = 0.$$

So we can find one immediate solution:

$$y(t) = y_0,$$

a constant solution. Since the solution is unique, that must be **the** solution.

This is a property of autonomous ODEs:

Equilibrium points. Consider an autonomous ODE $y' = f(y)$. The zeros of the function f are called *critical points*. They can also be called *equilibrium* or *stationary* points.

Important. Consider an autonomous ODE $y' = f(y)$ and let c be a zero of f , i.e. $f(c) = 0$. Then the constant function $y(t) = c$ is a solution of the ODE, called an *equilibrium solution*.

In an ODE where solutions are unique, these equilibrium solutions are extremely important, as they give bounds for all other solutions.

Example. Consider the autonomous ODE

$$y' = \sin(2y).$$

The *equilibrium solutions* for this ODE are

$$y = k\pi,$$

for all values $k \in \mathbb{Z}$.

That means that even without solving, we can infer that the solution passing through $y(0) = 1$, must satisfy

$$y(t) \in (0, \pi),$$

for all t .

Equilibrium solutions are even more important, because we can also study what happens between equilibrium solutions without having to actually solve the ODE.

If the function $f(y)$ is continuous, then its sign cannot change between equilibrium points, so the solutions will be monotonic between equilibrium solutions.

Example. Consider the same ODE:

$$y' = \sin(2y).$$

We can study whether solutions will be increasing or decreasing by studying the function $f(y)$.

y	\dots	-2π		$-\pi$		0		π		2π	\dots
$y' = \sin(2y)$		0	$+$	0	$-$	0	$+$	0	$-$	0	
$y(t)$	\dots	c	\nearrow	c	\searrow	c	\nearrow	c	\searrow	c	\dots

In a graph, we have

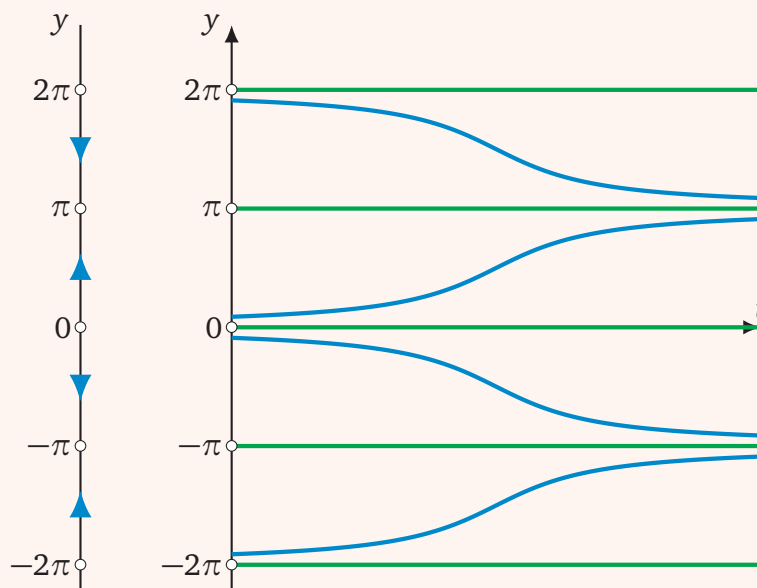

We can infer that the graphs will approach the constant solutions without touching because the derivative y' will become smaller and smaller the more they approach the equilibria. We also know that solutions cannot touch each other.

There is also a distinction that we make about equilibrium points that helps us understand the behaviour of solutions. We will study this distinction in the core exercises.

Population Models. The fact that these differential equations keep the same rate of change independently of time, makes them an ideal candidate when studying populations.

Video.

■ <https://youtu.be/swt-1et4pCI>



Practice Problems

- Show that all autonomous differential equations are separable.
- Consider the ODE $y' = \frac{1}{y}$. Then which of the statements below are true or false and justify your choice.
 - The solutions always stay positive.
 - The solutions always stay negative.
 - The solutions never change sign.
 - The solutions always change sign.
 - Some solutions change sign, and some don't.

- In this problem, we are trying to deduce some properties of slope fields.
 - Sketch a slope field for the autonomous ODE

$$y' = \cos(y).$$

- Sketch a slope field for the autonomous ODE

$$y' = \tan(y).$$

- What is a common property of all slope fields of autonomous ODEs?

- Consider the ODE

$$y' = \text{sign}(y) = \begin{cases} 1 & \text{if } y > 0 \\ 0 & \text{if } y = 0 \\ -1 & \text{if } y < 0 \end{cases}.$$

- What are the equilibrium solutions?
- Find two solutions that satisfy $y(0) = 0$.
- Are there solutions that satisfy $\lim_{t \rightarrow \infty} y(t) = \pi$?
- What are the possible limits of solutions as $t \rightarrow \infty$?

- Consider a function $f(y)$ such that

- $f(1) = 0$;
- f' is continuous for all y ;
- $f'(1) < 0$.

- Show that there is an open interval (a, b) satisfying $1 \in (a, b)$ and $f'(y) < 0$ for all $y \in (a, b)$.
- Show that
 - $f(y) > 0$ if $y \in (a, 1)$,
 - $f(y) < 0$ if $y \in (1, b)$.
- Consider the initial-value problem $y' = f(y)$ with $y(0) = y_0$. Show that this problem has a unique solution.
- Show that if $y_0 \in (a, b)$, then $\lim_{t \rightarrow \infty} y(t) = 1$.
- Write a Theorem about equilibrium points based on the results of this question.

- Consider a function $f(y)$ such that

- $f(2) = 0$;
- f' is continuous for all y ;
- $f'(2) > 0$.

Complete a study similar to question 5 for this function f .

- Consider an autonomous ODE $y' = f(y)$ with two stable equilibrium solutions $y = 1$ and $y = 2$ and where f is continuous.
 - Show that there must exist another equilibrium point $c \in (1, 2)$.
 - Show that if $f(y) \neq 0$ in $(1, 2)$, then there must exist an equilibrium point $c \in (1, 2)$ that is either semi-stable or unstable.

Consider the ODE from the video in the module.

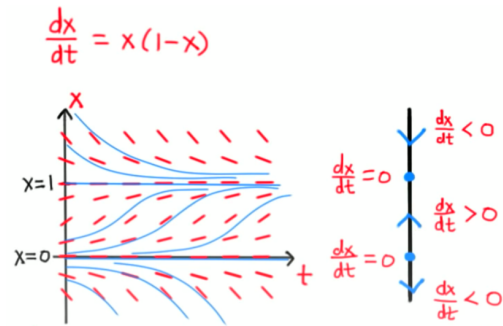

Select all the initial conditions that yield a decreasing solution.

- (a) $x(-2) = \sqrt{2}$
- (b) $x(20\,000) = 0.000000001$
- (c) $x(5) = \pi$
- (d) $x(0) = \frac{1}{2}$
- (e) $x(3) = -\frac{1}{2}$
- (f) $x(1000) = \frac{1}{e}$

29 Consider the differential equation $y' = f(y)$ where $f(y)$ is given by the following graph:

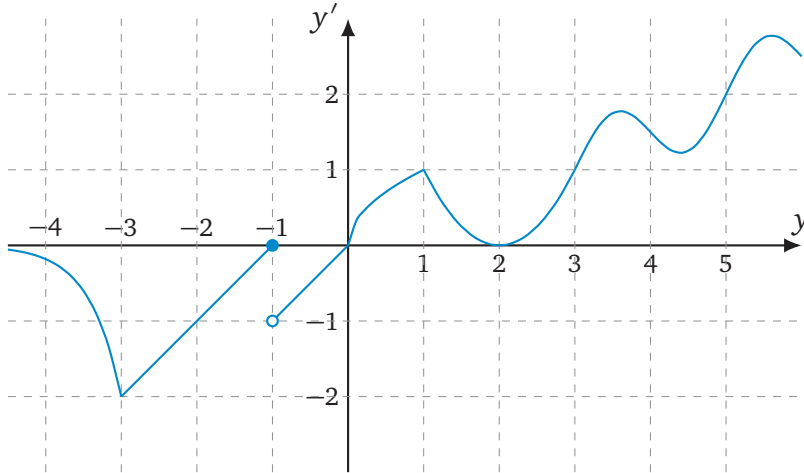

- 29.1 What are the equilibrium points?
- 29.2 Which equilibrium solutions are stable, unstable, or semi-stable?
- 29.3 Write a definition for a **stable**, **unstable**, and **semi-stable** equilibrium point.
- 29.4 Roughly, sketch a solution satisfying:
- (a) $y(0) = 2.5$.
 - (b) $y(0) = -\frac{1}{4}$.
 - (c) $y(1) = \frac{1}{4}$.
- 29.5 If $y(0) = 2$, then $y(t) =$
- 29.6 If $y(0) = \frac{1}{2}$, then $\lim_{t \rightarrow \infty} y(t) =$
- 29.7 If $y(0) = -2$, then $\max_{t \in [0, \infty)} y(t) =$

Consider a differential equation $y' = f(t, y)$ with the following slope field.

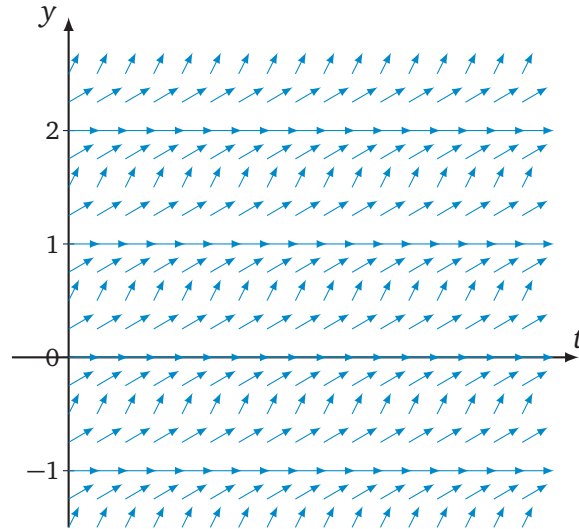

- 30.1 What are the equilibrium solutions of the ODE?
 30.2 Directly on the direction field above, sketch the solution of the problem

$$\begin{cases} y' = f(t, y) \\ y(0) = \frac{1}{4} \end{cases}$$

- 30.3 From the direction field above, circle the correct type(s) of this ODE? Justify your answer.
 (a) separable. (c) autonomous.
 (b) of first-order and linear. (d) none of the other options.
- 30.4 Assume that $y = g(t)$ and $y = h(t)$ are two solutions of the differential equation with $g(0) < h(0)$, then
 (select all the possible options)
 (a) $g(3) < h(3)$ (b) $g(3) = h(3)$ (c) $g(3) > h(3)$

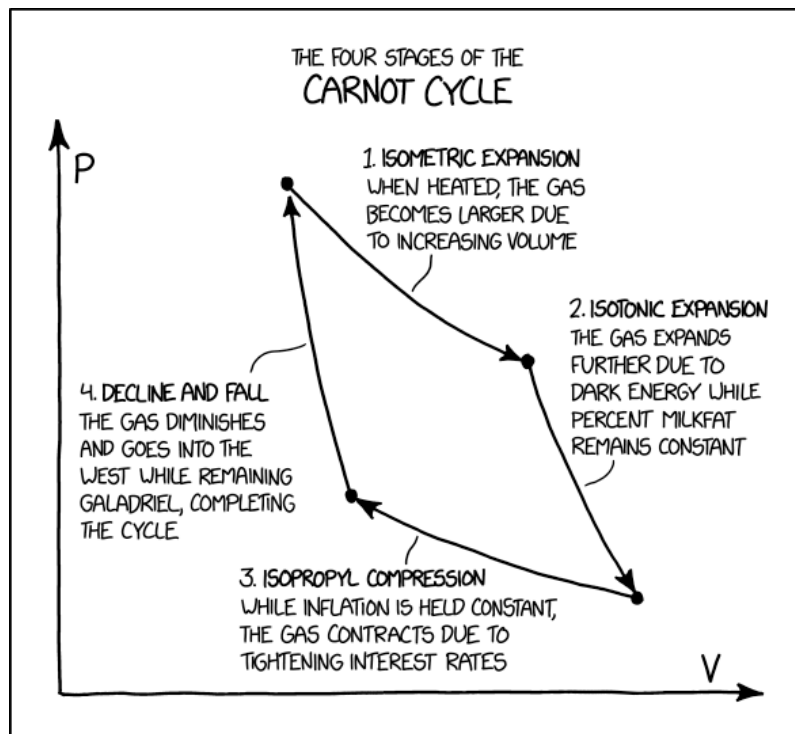

(image from xkcd - comic #2063)

Modelling Two Quantities

In this module you will learn

- how to model two or more inter-dependent quantities using systems

Often, when modelling something, we are faced with two or more quantities that depend on each other. This means that one equation is not enough, so we need to learn how to deal with a system of equations.

Just like we did in module 19, we will follow the step by step procedure developed in chapter 1.

Step 1. Define the problem

Example. We want to model two interacting populations, like the populations of bears and salmon in a specific natural park.

The first step is to decide on what we want to find at the end of the process. In this case, we want to know the number of individuals in each population and how they change as time passes. So we define:

- $b(t)$ = number of bears in the natural park at time t ;
- $s(t)$ = number of salmon in the natural park at time t .

Step 2. Build a mind map

Example. We start with both species in the centre:

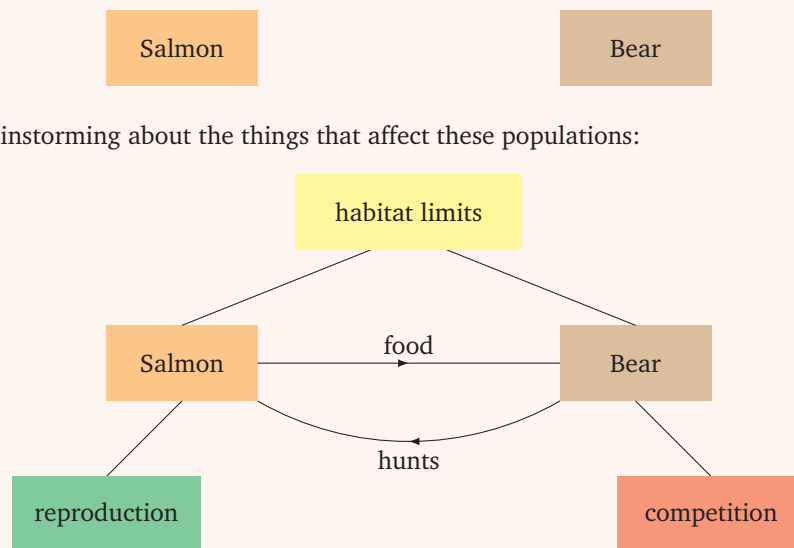

We can start brainstorming about the things that affect these populations:

Step 3. Make assumptions

Example. In this step, we discuss which of the boxes in the mind map we want to actually consider in our model, and which assumptions we need to make to consider them.

Let us start with how these species interact with each other:

1. Salmon provide food for bears: the bear population profits from each encounter with salmon. How does each bear-salmon encounter affect the bear population?
2. Bears hunt salmon: the salmon population is likely to decrease with each encounter with a bear. How

does each bear-salmon encounter affect the salmon population?

These two components are essential in our model, so we need to include them. It still leaves some freedom on how to do this.

There are other elements that we might want to include in our model:

3. Salmon reproduction: in the absence of predators and under ideal conditions, salmon should grow according to the Malthusian model, i.e. the rate of growth is proportional to the number of salmon;
4. Bear competition: bears are mainly predators, so without salmon, their numbers will decrease, also according to the Malthusian model;
5. Habitat limits: these species live in habitats that have limited resources, so we can consider a carrying capacity for each species.

To make the model simpler, we will *ignore habitat limits*. This means that this model will not be accurate if the populations become very large.

Step 4. Construct a model

Example. We will start with our populations:

- $b(t)$
- $s(t)$

and we will start adding components to each of these one by one.

For the first two items, we need to estimate the number of encounters salmon-bear. We assume that the number of encounters is proportional to the number of all possible encounters: $b(t)s(t)$.

1. Salmon provide food for bears: for every possible salmon-bear encounter, there is a probability that a bear actually encounters a salmon, and then there is a chance that the bear will catch the salmon. Each catch improves the possibility that the bear population will increase. All these put together means that this factor should increase the bear growth rate by $a b(t)s(t)$, where the constant a needs to be found.
2. Bears hunt salmon: similarly to the previous item, for every possible encounter, there is a probability that the bear actually encounters a salmon, and then there is a chance that the bear will catch the salmon. Every catch will decrease the salmon population, so the salmon growth rate will decrease by $c b(t)s(t)$, where the constant c needs to be found.

Right now we have the following model:

$$\begin{cases} b'(t) = a b(t)s(t) + \dots \\ s'(t) = -c b(t)s(t) + \dots \end{cases}$$

We continue with the other elements:

3. Salmon reproduction: this was explained before and should contribute to the salmon growth rate with the term $ds(t)$.
4. Bear competition: this was also explained above and should contribute to the bear growth rate with the term $-eb(t)$.
5. Habitat limits: we decided to ignore this.

We have the model:

$$\begin{cases} b'(t) = a b(t)s(t) - e b(t) \\ s'(t) = -c b(t)s(t) + d s(t) \end{cases}$$

To find the constants a, c, d, e , we would probably need to go back to Step 3 and make further assumptions related to the way that we are measuring them.

Step 5. Model assessment

Example.

We can do several things here.

One of the things that we can do is approximate its solutions using Euler's Method discussed in Module 16. Let us assume, for this example the constants: $a = 1$, $e = 10$, $c = 1$, $d = 5$ and a time step $\Delta t = 0.5$ and we assumed an initial population of $b(0) = 6$ and $s(0) = 9$. Then we obtain the graph below:

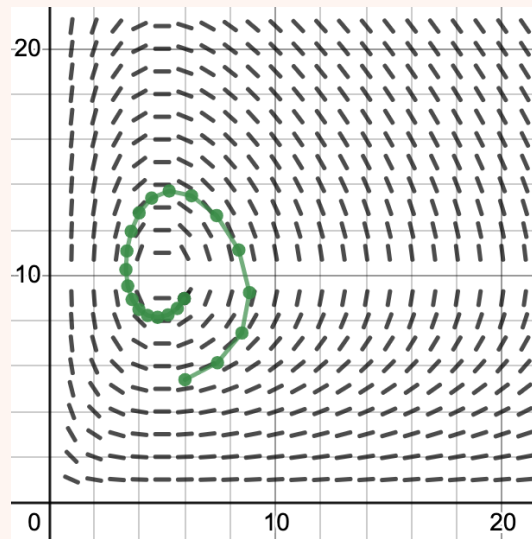

■ <https://www.desmos.com/calculator/zywspstwk>



The x -axis is the bear population while the y -axis is the salmon population. Each dot gives an approximation of the populations $\Delta t = 0.5$ time units after the previous approximation.

From this approximation, we can say infer that this model creates a population cycle, but it seems to spiral outwards:

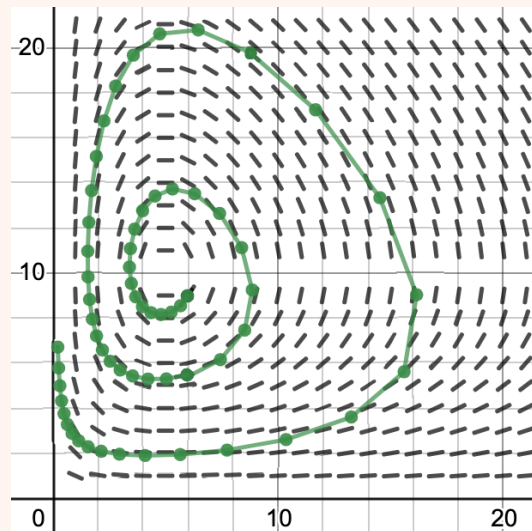

- Is having a population cycle a feature that our model should have?
- Is the spiralling outwards a feature we want in our model?
- Is the spiralling a feature of the model or the approximation? If it's from the approximation, how does the model behave?

I'll let you brainstorm and think of other ways you can assess this model.

There are lots of other tools to create slope fields and approximate solutions of systems of ODEs.

- GeoGebra approximation of the same model, called the Lotka-Volterra model:

<https://www.geogebra.org/m/KqNV7eHB>



- WolframAlpha slope field of the same model:

<https://uoft.me/modelling-sys-wa>

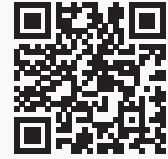

- WolframAlpha stream plot of the same model:

<https://uoft.me/modelling-sys-wa2>



- There are also better methods of approximating ODEs and systems, e.g. Runge-Kutta methods

https://en.wikipedia.org/wiki/Runge-Kutta_methods



Practice Problems

- 1 Create a model for two cooperating populations, like sharks and remoras.
- 2 We have a spring attached to a mass and with a dashpot.
 - (a) Model the position of the mass as time changes.
 - (b) Obtain a system of two first-order ODEs. Remember to explain how the new functions relate to the spring-mass-dashpot system.
- 3 Model a vehicle with a special engine that provides an acceleration to the car proportional to the fuel left.
- 4 Imagine two twin babies and model their crying volume. Assume that they naturally become tired and stop crying if alone, but they cry more if the other twin is crying.
- 5 Model a ping pong ball travelling through the air.

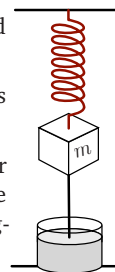

- 6 Create a simplified model for a tree, considering the height of the tree and its leaf area and how they affect each other.

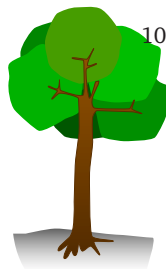

- 7 Create a model on how a student's confidence in her

own ability affects her learning/knowledge of a subject. Remember the Ebbinghaus' "forgetting curve".

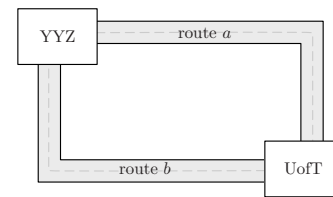

- 8 Imagine that there are two ways to travel from UofT to Toronto's Pearson airport (YYZ). Both paths take the same time if there is no traffic. You want to direct people on the fastest path. Create a model for choosing the fastest path.
- 9 Create a model for the sales of a specific brand of sneakers. The goal is to capture the influence of famous people and non-famous people on each other's purchases.
- 10 Create a model on how the population and the cost of living in Toronto affect each other.

-
- 31 We want to model two competing populations, like cheetahs and lions: they don't hunt each other, but they hunt the same prey.
- 31.1 Create a model for these two populations.
 - 31.2 Using Desmos or WolframAlpha, create a slope field in the plane where the horizontal axis is one population and the vertical one is the other.
 - 31.3 Using the slope field, deduce some properties of your model and discuss how closely it matches what you expect from these populations.
 - 31.4 Extend the model to include a population of antelopes.

A cheetah is chasing an antelope. We want a model of their positions as they run.

Systems of two linear ODEs with constant coefficients

In this module you will learn

- how to solve systems of two linear first-order ODEs with constant coefficients

First, a system of two first-order ODEs has the form:

$$\begin{cases} x'(t) = f(t, x(t), y(t)) \\ y'(t) = g(t, x(t), y(t)) \end{cases}$$

where the functions f and g are continuous and have continuous partial derivatives.

This system could be nonlinear. We are only considering **linear systems with constant coefficients**, which means that they have a very specific form:

$$\begin{cases} x'(t) = ax(t) + by(t) + e \\ y'(t) = cx(t) + dy(t) + f \end{cases} \Leftrightarrow \begin{bmatrix} x'(t) \\ y'(t) \end{bmatrix} = \begin{bmatrix} a & b \\ c & d \end{bmatrix} \begin{bmatrix} x(t) \\ y(t) \end{bmatrix} + \begin{bmatrix} e \\ f \end{bmatrix} \Leftrightarrow \vec{r}'(t) = A\vec{r}(t) + \vec{b}$$

where

$$\vec{r}(t) = \begin{bmatrix} x(t) \\ y(t) \end{bmatrix}, \quad A = \begin{bmatrix} a & b \\ c & d \end{bmatrix} \quad \text{and} \quad \vec{b} = \begin{bmatrix} e \\ f \end{bmatrix}.$$

The unknown functions we are trying to find are $x(t)$ and $y(t)$, or equivalently, $\vec{r}(t)$.

Homogeneous Systems. These are systems of the form above with $\vec{b} = \vec{0}$.

This means that we want to find all functions $\vec{r}(t)$ that satisfy

$$\vec{r}'(t) = A\vec{r}(t).$$

Example. Let us start with an example of the same problem where $\vec{r}(t)$ is a “one-dimensional” vector, a scalar function $u(t)$, and the matrix A is a “one-dimensional matrix”, a constant a .

We want to solve the problem

$$u'(t) = a \cdot u(t).$$

We have seen how to solve these kind of problems before. The solutions are

$$u(t) = ce^{at},$$

where c can be any constant.

In our two-dimensional case, it is a little more complicated. We can't just write e^{At} where A is a matrix (this expression can make sense, but we would have to find out what is the exponential of a matrix).

So we can use the example above to make an **educated guess**: the solution should look like an exponential:

$$\vec{r}(t) = \vec{c}e^{\lambda t},$$

where \vec{c} is a constant vector.

If our guess is correct, to find $\vec{r}(t)$, we only need to find λ and \vec{c} .

Let us see what happens when we use this guess and plug it into the system of ODEs:

$$\begin{aligned} \vec{r}'(t) = A\vec{r}(t) &\Leftrightarrow \vec{c}\lambda e^{\lambda t} = A\vec{c}e^{\lambda t} \\ &\Leftrightarrow \vec{c}\lambda = A\vec{c}. \end{aligned}$$

This is a problem you have seen before – and eigenvalue-eigenvector problem:

- λ can be any eigenvalue of the matrix A
- \vec{v} can be any eigenvector of A associated with λ

This means that we might have multiple choices for eigenvalues and eigenvectors, or even that eigenvalues and eigenvectors involve complex numbers. Let us split our study of possible solutions in three cases.

3.1 Two real and distinct eigenvalues

Example. Consider the problem

$$\vec{r}'(t) = \begin{bmatrix} 10 & 18 \\ -6 & -11 \end{bmatrix} \vec{r}(t).$$

Then, the eigenvalues and eigenvectors of the matrix are

- $\lambda_1 = -2$ with eigenvector $\vec{v}_1 = \begin{bmatrix} 3 \\ -2 \end{bmatrix}$
- $\lambda_2 = 1$ with eigenvector $\vec{v}_2 = \begin{bmatrix} 2 \\ -1 \end{bmatrix}$

This means that we found two solutions:

$$\vec{r}_1(t) = \begin{bmatrix} 3 \\ -2 \end{bmatrix} e^{-2t} \quad \text{and} \quad \vec{r}_2(t) = \begin{bmatrix} 2 \\ -1 \end{bmatrix} e^t.$$

Then, we can show that

$$\vec{r}(t) = c_1 \begin{bmatrix} 3 \\ -2 \end{bmatrix} e^{-2t} + c_2 \begin{bmatrix} 2 \\ -1 \end{bmatrix} e^t$$

is also a solution of the problem for any constants c_1 and c_2 .

In fact, we can show that this formula captures all possible solutions for this problem.

Video.

- <https://youtu.be/YUjdyKhWt6E>



3.2 Two complex eigenvalues

We actually don't need to know a lot about complex numbers to be able to understand how to solve this case. The results about complex values that are necessary to know will be included in the box below.

Complex numbers.

- A complex number is a number of the form $z = a + ib$ where i is called the imaginary constant and satisfies $i^2 = -1$.
- Given a complex number $z = a + ib$, we call $\bar{z} = a - ib$ its complex conjugate. It satisfies:

$$z \cdot \bar{z} = a^2 + b^2 = |z|^2.$$
- If a matrix has real components and two complex eigenvalues, then the eigenvalues are complex conjugates of each other. Moreover, the eigenvectors are also complex conjugates of each other.
- Euler's Formula: $e^{i\theta} = \cos(\theta) + i \sin(\theta)$.

Example. Consider the problem

$$\vec{r}'(t) = \begin{bmatrix} 1 & 1 \\ -1 & 1 \end{bmatrix} \vec{r}(t).$$

Then, the eigenvalues and eigenvectors of the matrix are

- $\lambda_1 = 1 + i$ with eigenvector $\vec{v}_1 = \begin{bmatrix} -i \\ 1 \end{bmatrix}$

- $\lambda_2 = 1 - i$ with eigenvector $\vec{v}_2 = \begin{bmatrix} i \\ 1 \end{bmatrix}$

This means that we found two solutions:

$$\vec{r}_1(t) = \begin{bmatrix} -i \\ 1 \end{bmatrix} e^{(1+i)t} \quad \text{and} \quad \vec{r}_2(t) = \begin{bmatrix} i \\ 1 \end{bmatrix} e^{(1-i)t}.$$

Then, all solutions of this system of ODEs can be expressed as

$$\vec{r}(t) = c_1 \begin{bmatrix} -i \\ 1 \end{bmatrix} e^{(1+i)t} + c_2 \begin{bmatrix} i \\ 1 \end{bmatrix} e^{(1-i)t}.$$

There is a problem with the form of these solutions: they involve complex numbers!

Imagine that we start with a problem where we have two (real) quantities that interact with each other through this system of differential equations. Then we expect these quantities to measure in real numbers, not complex.

- This means that we expect *the imaginary part of these solutions to cancel out*.

So let us manipulate this formula using Euler's formula and see if we can re-write in such a way that doesn't involve complex numbers.

We have:

$$e^{(1+i)t} = e^t \cdot e^{it} = e^t (\cos(t) + i \sin(t))$$

$$e^{(1-i)t} = e^t \cdot e^{-it} = e^t (\cos(t) - i \sin(t))$$

So our solution expands to:

$$\vec{r}(t) = c_1 \begin{bmatrix} -i \\ 1 \end{bmatrix} e^t (\cos(t) + i \sin(t)) + c_2 \begin{bmatrix} i \\ 1 \end{bmatrix} e^t (\cos(t) - i \sin(t)).$$

We can now manipulate this expression:

$$\begin{aligned} \vec{r}(t) &= e^t \begin{bmatrix} -ic_1(\cos(t) + i \sin(t)) + ic_2(\cos(t) - i \sin(t)) \\ c_1(\cos(t) + i \sin(t)) + c_2(\cos(t) - i \sin(t)) \end{bmatrix} \\ &= e^t \begin{bmatrix} (c_1 + c_2) \sin(t) - i(c_1 - c_2) \cos(t) \\ (c_1 + c_2) \cos(t) + i(c_1 - c_2) \sin(t) \end{bmatrix} \\ &= e^t \left((c_1 + c_2) \begin{bmatrix} \sin(t) \\ \cos(t) \end{bmatrix} + i(c_1 - c_2) \begin{bmatrix} -\cos(t) \\ \sin(t) \end{bmatrix} \right) \end{aligned}$$

So now we do something that might look like cheating. We define:

$$a_1 = c_1 + c_2 \quad \text{and} \quad a_2 = i(c_1 - c_2).$$

Then the solution is

$$\vec{r}(t) = a_1 \begin{bmatrix} \sin(t) \\ \cos(t) \end{bmatrix} e^t + a_2 \begin{bmatrix} -\cos(t) \\ \sin(t) \end{bmatrix} e^t.$$

This last form doesn't include any complex numbers and is equivalent to the previous form.

It may look like the final solution above still includes complex numbers in the constants a_1 and a_2 . To convince yourself that this is not the case, solve the following exercise.

Find the unique solution of

$$\vec{r}'(t) = \begin{bmatrix} 1 & 1 \\ -1 & 1 \end{bmatrix} \vec{r}(t) \quad \text{with} \quad \vec{r}(0) = \begin{bmatrix} -3 \\ 2 \end{bmatrix}$$

Find the constants c_1, c_2 and then the constants a_1, a_2 . Which ones are complex and which ones are real?

Video.

■ <https://youtu.be/TRVS5Wo9LoM>



3.3 One real repeated eigenvalue

Example. Consider the problem

$$\vec{r}'(t) = \begin{bmatrix} 5 & 0 \\ 1 & 5 \end{bmatrix} \vec{r}(t).$$

Then, there is only one eigenvalue with one eigenvector

■ $\lambda_1 = 5$ with eigenvector $\vec{v}_1 = \begin{bmatrix} 0 \\ 1 \end{bmatrix}$, which yield a solution $\vec{r}_1(t) = c_1 \begin{bmatrix} 0 \\ 1 \end{bmatrix} e^{5t}$.

This is a **problem** because we need two solutions to put together and obtain two constants, as in the two previous cases.

To convince yourself that it is a problem, try solving the problem above with initial conditions

$$\vec{r}(0) = \begin{bmatrix} 0 \\ 4 \end{bmatrix}.$$

What about with initial conditions

$$\vec{r}(0) = \begin{bmatrix} 1 \\ 4 \end{bmatrix} \quad ?$$

This means that we are missing one solution – that will enable us to solve the problem for any initial conditions.

Let us re-write the original problem in a different form by letting

$$\vec{r}(t) = \begin{bmatrix} x(t) \\ y(t) \end{bmatrix}.$$

Then we have

$$\begin{cases} x'(t) = 5x(t) \\ y'(t) = x(t) + 5y(t) \end{cases}$$

These are two ODEs, but the first one is independent of the second one. We can solve the first and then tackle the second one.

$$\begin{cases} x(t) = c_2 e^{5t} \\ y(t) = c_1 e^{5t} + c_2 t e^{5t} \end{cases} \Leftrightarrow \vec{r}(t) = \begin{bmatrix} c_2 \\ c_1 + c_2 t \end{bmatrix} e^{5t} \Leftrightarrow \vec{r}(t) = c_1 \begin{bmatrix} 0 \\ 1 \end{bmatrix} e^{5t} + c_2 \begin{bmatrix} 1 \\ t \end{bmatrix} e^{5t}$$

Observe that the solution we found has the form:

$$\vec{r}(t) = c_1 \underbrace{\begin{bmatrix} 0 \\ 1 \end{bmatrix}}_{\text{solution } \vec{r}_1(t)} e^{5t} + c_2 \left(\underbrace{\begin{bmatrix} 1 \\ 0 \end{bmatrix}}_{\text{new vector } \vec{w}} e^{5t} + \underbrace{\begin{bmatrix} 0 \\ 1 \end{bmatrix}}_{\vec{v}_1} t e^{5t} \right).$$

So we can make another **educated guess** that the solution we were missing has the form:

$$\vec{r}_2(t) = (\vec{w} + \vec{v}_1 t) e^{\lambda t}.$$

With this form in mind, we can plug it into the system of ODEs $\vec{r}'(t) = A\vec{r}(t)$, which has exactly one eigenvalue λ , to get:

$$\lambda \vec{w} e^{\lambda t} + \lambda \vec{v}_1 t e^{\lambda t} + \vec{v}_1 e^{\lambda t} = A\vec{w} e^{\lambda t} + A\vec{v}_1 t e^{\lambda t}$$

which is equivalent to:

$$\lambda \vec{w} + \underbrace{\lambda \vec{v}_1}_{=A\vec{v}_1} t + \vec{v}_1 = A\vec{w} + A\vec{v}_1 t \iff (\lambda I - A)\vec{w} = \vec{v}_1$$

Since at this point we already know λ and \vec{v}_1 , we can now find \vec{w} in a similar way used to find the eigenvector \vec{v}_1 . The vector \vec{w} is called a **generalized eigenvector** of A associated with the eigenvalue λ .

Video.

■ <https://youtu.be/hCShTLmeZN4>



Practice Problems

1 Find the general solution of the problem $\vec{r}'(t) = A\vec{r}(t)$ for the following matrices:

- | | |
|--|---|
| (a) $A = \begin{bmatrix} -7 & 6 \\ -9 & 8 \end{bmatrix};$ | (g) $A = \begin{bmatrix} 0 & 1 \\ -4 & -4 \end{bmatrix};$ |
| (b) $A = \begin{bmatrix} 22 & 24 \\ -15 & -16 \end{bmatrix};$ | (h) $A = \begin{bmatrix} -4 & -6 \\ 2 & 3 \end{bmatrix};$ |
| (c) $A = \begin{bmatrix} 0 & 1 \\ -5 & 0 \end{bmatrix};$ | (i) $A = \begin{bmatrix} 2 & -3 \\ 0 & 2 \end{bmatrix};$ |
| (d) $A = \begin{bmatrix} 0 & 1 \\ 5 & 0 \end{bmatrix};$ | (j) $A = \begin{bmatrix} 2 & 0 \\ 0 & 2 \end{bmatrix};$ |
| (e) $A = \begin{bmatrix} 1 & \sqrt{3} \\ \sqrt{3} & -1 \end{bmatrix};$ | (k) $A = \begin{bmatrix} 0 & 0 \\ 1 & 0 \end{bmatrix};$ |
| (f) $A = \begin{bmatrix} 1 & \sqrt{3} \\ -\sqrt{3} & 1 \end{bmatrix};$ | (l) $A = \begin{bmatrix} 0 & 0 \\ 0 & 1 \end{bmatrix};$ |

2 For each of the problems in the previous exercise, find the solution that satisfies the initial conditions:

- (i) $\vec{r}(0) = \begin{bmatrix} 0 \\ 0 \end{bmatrix};$
 (ii) $\vec{r}(0) = \begin{bmatrix} 1 \\ 3 \end{bmatrix};$
 (iii) $\vec{r}(1) = \begin{bmatrix} -2 \\ 2 \end{bmatrix}.$

3 Consider the problem $\vec{r}'(t) = \begin{bmatrix} 2 & 0 \\ 1 & 3 \end{bmatrix} \vec{r}(t) + \begin{bmatrix} -2 \\ 11 \end{bmatrix}.$

- (a) Show that $\vec{e}(t) = \begin{bmatrix} 1 \\ -4 \end{bmatrix}$ is a solution of this problem.

(b) Find the general solution of

$$\vec{u}'(t) = \begin{bmatrix} 2 & 0 \\ 1 & 3 \end{bmatrix} \vec{u}(t).$$

(c) Let $\vec{r}(t) = \vec{u}(t) + \vec{e}(t)$. Show that this is a solution of the original problem.

(d) Let $\vec{r}_1(t)$ and $\vec{r}_2(t)$ be two solutions of the original problem.

- i. Is $\vec{r}_1(t) + \vec{r}_2(t)$ a solution?
 ii. Is $3\vec{r}_1(t)$ a solution?
 iii. Write a result on how one can safely combine solutions of non-homogeneous problems.

4 Consider the problem $\vec{r}'(t) = \begin{bmatrix} 1 & 2 \\ 3 & 0 \end{bmatrix} \vec{r}(t) + \begin{bmatrix} -5 \\ 3 \end{bmatrix}.$

(a) Observe that this system is an autonomous system of ODEs. What is the equilibrium solution?

(b) Sketch its phase portrait using WolframAlpha's streamplot function. What can you observe from the phase portrait?

(c) "Redefine the centre": Let the equilibrium solution you just found be called \vec{e} . Consider $\vec{u}(t) = \vec{r}(t) - \vec{e}$, where $\vec{r}(t)$ is the solution of the original problem. Show that

$$\vec{u}'(t) = A\vec{u}(t).$$

- (d) Find $\vec{u}(t)$.
 (e) Find $\vec{r}(t)$.

- (f) Write a procedure to solve any problem of the form

$$\vec{r}(t) = A\vec{r}(t) + \vec{b}.$$

5 Consider the problem $\frac{d\vec{r}}{dt} = \begin{bmatrix} 4 & -1 \\ 8 & -2 \end{bmatrix} \vec{r} - \begin{bmatrix} 5 \\ 10 \end{bmatrix}$.

- (a) Find $\vec{r}(t)$.
 (b) What is the solution that satisfies $\vec{r}(0) = \begin{bmatrix} 2 \\ 3 \end{bmatrix}$?
 (c) Sketch the phase portrait.

- 6 Consider the problem $\vec{r}'(t) = A\vec{r}(t)$. Assume that we have two solutions $\vec{r}_1(t)$ and $\vec{r}_2(t)$.

- (a) Show that $\vec{r}(t) = \vec{r}_1(t) + \vec{r}_2(t)$ is a solution also.
 (b) Show that $\vec{r}(t) = 2\vec{r}_1(t) - 3\vec{r}_2(t)$ is a solution also.
 (c) Find all possible solutions of the problem.

7 Consider the problem $\vec{r}'(t) = \begin{bmatrix} 1 & -2 \\ -2 & 1 \end{bmatrix} \vec{r}(t)$.

- (a) Find the solution that satisfies the initial condition $\vec{r}(0) = \begin{bmatrix} 1 \\ 0 \end{bmatrix}$. Call it $\vec{u}(t)$.
 (b) Find the solution that satisfies the initial condition $\vec{r}(0) = \begin{bmatrix} 0 \\ 1 \end{bmatrix}$. Call it $\vec{v}(t)$.
 (c) Define the matrix function

$$\Phi(t) = [\vec{u}(t) \mid \vec{v}(t)] = \begin{bmatrix} u_1(t) & v_1(t) \\ u_2(t) & v_2(t) \end{bmatrix}.$$

Show that $\vec{r}(t) = \Phi(t)\vec{r}_0$ is a solution of the original system of ODEs. Which initial condition does it satisfy?

- (d) Write a result relating $\Phi(t)$ to the solution of initial-value problems.

- 8 Consider a system of ODEs $\vec{r}'(t) = A\vec{r}(t)$ with two solutions $\vec{r}_1(t)$ and $\vec{r}_2(t)$.

We want to study the conditions that are necessary on the solutions \vec{r}_1 and \vec{r}_2 to guarantee that we can solve any initial-value problem.

- (a) What is the general solution for this problem?
 (b) If the initial condition is $\vec{r}(0) = \begin{bmatrix} 1 \\ 2 \end{bmatrix}$, then what are the conditions on \vec{r}_1, \vec{r}_2 ?
 (c) If the initial condition is $\vec{r}(0) = \vec{r}_0$, then what are the conditions on \vec{r}_1, \vec{r}_2 ?

- 9 Consider a system of ODEs $\vec{r}'(t) = A\vec{r}(t)$ with two solutions $\vec{r}_1(t), \vec{r}_2(t)$.

Let $R(t)$ be the matrix $R(t) = [\vec{r}_1(t) \mid \vec{r}_2(t)]$ and let $W(t) = \det R(t)$.

- (a) Show that $W(t)$ is a solution of $W' = (a_{11} + a_{22})W$.
 (b) Solve the ODE above to obtain an expression for $W(t)$.
 (c) Show that $W(t)$ is either identically zero, or it's never zero.
 (d) Use this result to simplify your answer to problem 8(c).

Consider a cheetah-lion inspired problem:

$$\frac{d\vec{r}}{dt} = \begin{bmatrix} 3 & -2 \\ -1 & 4 \end{bmatrix} \vec{r}.$$

- 33.1 Find the two solutions \vec{r}_1, \vec{r}_2 .
- 33.2 Is $\vec{r}_1(t) + \vec{r}_2(t)$ a solution?
- 33.3 Is $\vec{r}_1(t) - \vec{r}_2(t)$ a solution?
- 33.4 Is $2\vec{r}_1(t) + 3\vec{r}_2(t)$ a solution?
- 33.5 What is the general solution?
- 33.6 Find the solution that satisfies $\vec{r}(0) = \begin{bmatrix} 6 \\ 7 \end{bmatrix}$?

34 Consider a problem:

$$\frac{d\vec{r}}{dt} = \begin{bmatrix} 2 & -5 \\ 1 & -2 \end{bmatrix} \vec{r}.$$

34.1 Find the general solution.

34.2 Find the solution that satisfies $\vec{r}(0) = \begin{bmatrix} 6 \\ 7 \end{bmatrix}$?

35 Consider a problem:

$$\frac{d\vec{r}}{dt} = \begin{bmatrix} 2 & -5 \\ 1 & -2 \end{bmatrix} \vec{r} - \begin{bmatrix} 9 \\ 4 \end{bmatrix}.$$

35.1 Find the equilibrium solution.

35.2 Find the general solution.

35.3 Find the solution that satisfies $\vec{r}(0) = \begin{bmatrix} 8 \\ 6 \end{bmatrix}$?

Phase Portraits

In this module you will learn

- how to sketch a phase portrait for a linear system of ODEs with constant coefficients
- how to use a phase portrait to deduce properties of solutions

When we solve a system of two ODEs, we obtain two functions $x(t)$ and $y(t)$, so when we want to graph solutions, we have a problem:

- Should we sketch each of these functions separately?
- Should we sketch them together?
- Should we sketch the path as if a particle is moving with coordinates $x(t)$ and $y(t)$?

Example. Consider the initial-value problem

$$\frac{d\vec{r}}{dt} = \begin{bmatrix} 0 & 1 \\ -1 & 0 \end{bmatrix} \vec{r} \quad \text{with} \quad \vec{r}(0) = \begin{bmatrix} 0 \\ 1 \end{bmatrix},$$

which has the solution

$$\vec{r}(t) = \begin{bmatrix} \sin(t) \\ \cos(t) \end{bmatrix}.$$

Which of the following ways are better?

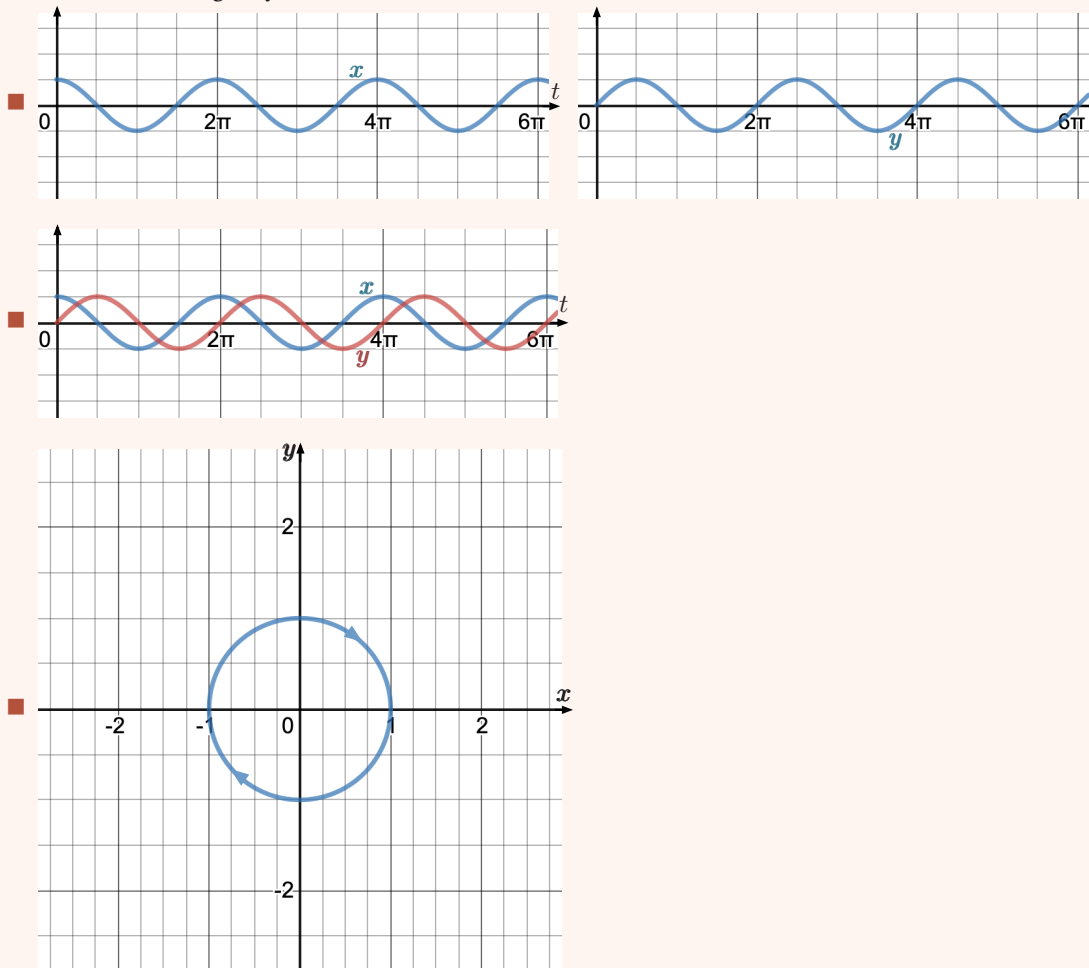

There is no correct answer, but the last graph gives more information on how the two quantities interact with each other, so we will focus on that type of graph.

The graphs in the example above are graphs of one specific solution. They don't give us an idea of what all other possible solutions of the system look like.

Example. In the last graph of the example, what are the other solutions?

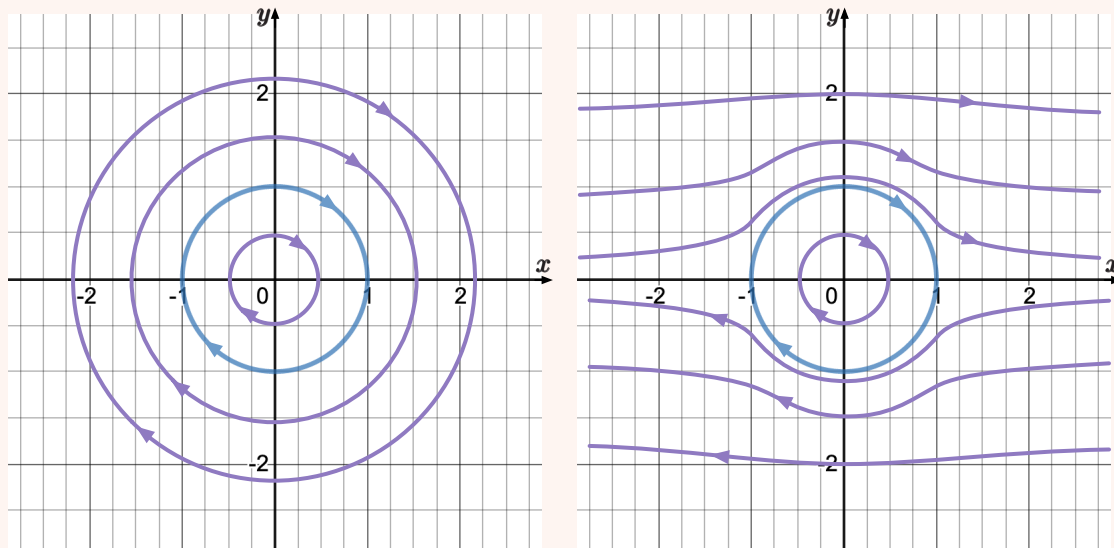

Sketching **phase portraits** for systems of two first-order linear ODEs is important because it gives us insight on how the two components affect each other for all solutions.

Example. Consider the problem

$$\frac{d\vec{r}}{dt} = \begin{bmatrix} -2 & 3 \\ -3 & -2 \end{bmatrix} \vec{r},$$

where the matrix A has the eigenvalues and eigenvectors:

- Eigenvalues $\lambda_{\pm} = -2 \pm 3i$ with eigenvectors $v_{\pm} = \begin{bmatrix} \mp i \\ 1 \end{bmatrix}$

This means that the general solution has the form

- $\vec{r}(t) = a_1 \begin{bmatrix} -i \\ 1 \end{bmatrix} e^{(-2+3i)t} + a_2 \begin{bmatrix} i \\ 1 \end{bmatrix} e^{(-2-3i)t}$

or

- $\vec{r}(t) = c_1 \begin{bmatrix} \sin(3t) \\ \cos(3t) \end{bmatrix} e^{-2t} + c_2 \begin{bmatrix} -\cos(3t) \\ \sin(3t) \end{bmatrix} e^{-2t}$

We can use the general form and start sketching some solutions.

- Let $c_1 = 1$ and $c_2 = 0$ and we obtain

$$\vec{r}(t) = \begin{bmatrix} \sin(3t) \\ \cos(3t) \end{bmatrix} e^{-2t}.$$

To sketch this solution, let us start by ignoring the term e^{-2t} .

So we want to sketch $\vec{r}(t) = \begin{bmatrix} \sin(3t) \\ \cos(3t) \end{bmatrix}$:

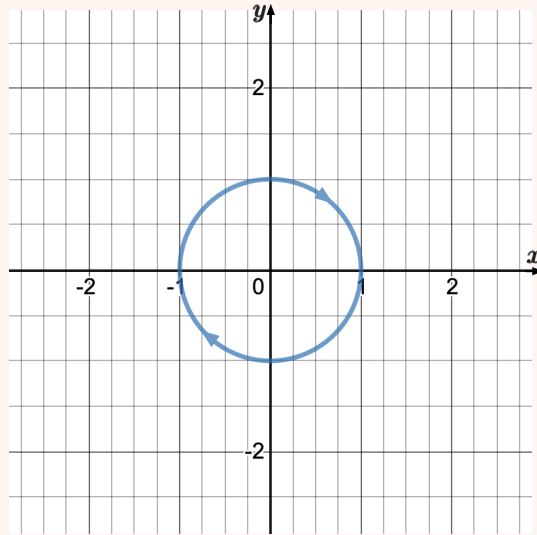

The path is going in circles in the clockwise direction.

By multiplying the solution by e^{-2t} , which starts at 1 when $t = 0$ and keeps decreasing towards 0 as t increases, we are creating a graph that keeps revolving around the origin as it converges towards the origin, yielding a spiral.

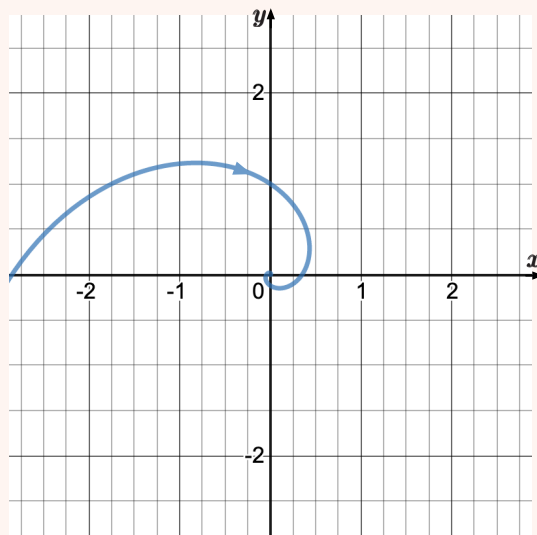

In this graph, we also include the graph for $t < 0$.

- Let $c_1 = -1$ and $c_2 = 0$ and we obtain

$$\vec{r}(t) = \begin{bmatrix} -\sin(3t) \\ -\cos(3t) \end{bmatrix} e^{-2t}$$

We add this graph to the previous one.

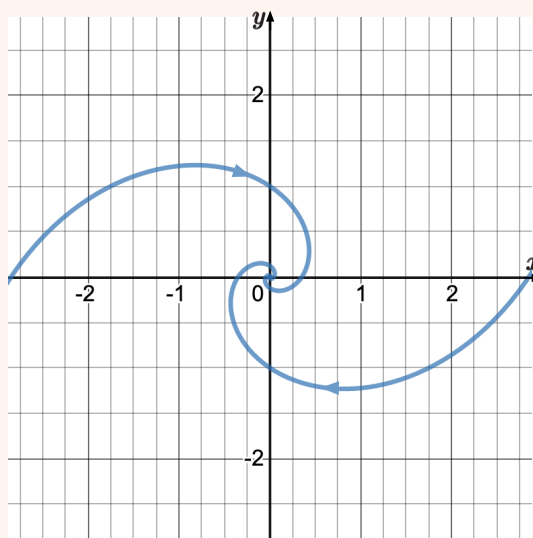

■ Let $c_1 = 0$ and $c_2 = \pm 1$ and we obtain

$$\vec{r}(t) = \begin{bmatrix} \mp \cos(3t) \\ \pm \sin(3t) \end{bmatrix} e^{-2t}.$$

And add these to the graph:

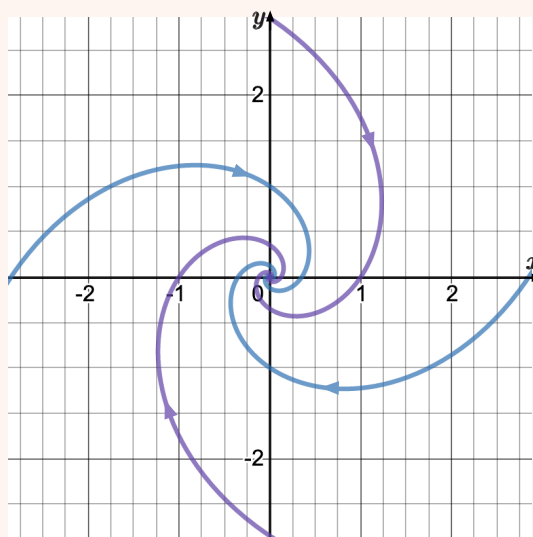

Sometimes, we need some solutions of the type $c_1 = \pm 1$ and $c_2 = \pm 1$ to get some different types of solutions, but we'll let you discover that on the core exercises.

These four solutions seem to give a good idea of all possible solutions: clockwise spirals converging to the origin.

Also observe that $\vec{r}(t) = \begin{bmatrix} 0 \\ 0 \end{bmatrix}$ is a solution of the system, so this system has an equilibrium solution. This kind of equilibrium is called a **spiral sink** and it is **asymptotically stable**. This means that it is a spiral and it converges to the equilibrium (the origin).

Video.

■ https://youtu.be/nyI_JPDrJ_I





Practice Problems

- 1 For each matrix from practice problem 1 from Module 17, sketch its phase portrait and label them as asymptotically stable or unstable. The system of ODEs is $\vec{r}'(t) = A\vec{r}(t)$ for the following matrices:

(a) $A = \begin{bmatrix} -7 & 6 \\ -9 & 8 \end{bmatrix};$	(g) $A = \begin{bmatrix} 0 & 1 \\ -4 & -4 \end{bmatrix}$
(b) $A = \begin{bmatrix} 22 & 24 \\ -15 & -16 \end{bmatrix};$	This is called an im-
(c) $A = \begin{bmatrix} 0 & 1 \\ -5 & 0 \end{bmatrix}$	proper node.
This is called a cen-	(h) $A = \begin{bmatrix} -4 & -6 \\ 2 & 3 \end{bmatrix};$
tre, which is stable, but	(i) $A = \begin{bmatrix} 2 & -3 \\ 0 & 2 \end{bmatrix};$
not asymptotically sta-	(j) $A = \begin{bmatrix} 2 & 0 \\ 0 & 2 \end{bmatrix};$
ble. Can you tell why?	This is called a proper
(d) $A = \begin{bmatrix} 0 & 1 \\ 5 & 0 \end{bmatrix};$	node.
(e) $A = \begin{bmatrix} 1 & \sqrt{3} \\ \sqrt{3} & -1 \end{bmatrix};$	(k) $A = \begin{bmatrix} 0 & 0 \\ 1 & 0 \end{bmatrix};$
(f) $A = \begin{bmatrix} 1 & \sqrt{3} \\ -\sqrt{3} & 1 \end{bmatrix};$	(l) $A = \begin{bmatrix} 0 & 0 \\ 0 & 1 \end{bmatrix};$

- 2 Consider a system of ODEs $\vec{r}'(t) = A\vec{r}(t)$. For each part, give an example of eigenvalues and eigenvectors of A that would yield the required phase portrait:

- Spiral sink (asymptotically stable);
- Spiral source (unstable);
- Centre (stable);
- Sink node (asymptotically stable);
- Source node (unstable);
- Saddle point (unstable);
- Improper node (stable);
- Improper node (unstable);
- Proper node (stable);
- Proper node (unstable);

- 3 Consider the system of ODEs

$$\vec{r}'(t) = \begin{bmatrix} 1 & 1 \\ k & 1 \end{bmatrix} \vec{r}(t).$$

This system of ODEs changes behaviour depending on the parameter k .

- Label the behaviour of the system for different values of k .
- We call the k^* the critical value of k when the behaviour is different for $k < k^*$ and for $k > k^*$. For the critical value of k , sketch the phase portrait.

- 4 Consider the system of ODEs

$$\vec{r}'(t) = \begin{bmatrix} 0 & 1 \\ -4 & -k \end{bmatrix} \vec{r}(t).$$

This system of ODEs changes behaviour depending on the parameter k .

- Label the behaviour of the system for different values of k .
- We call the k^* the critical value of k when the behaviour is different for $k < k^*$ and for $k > k^*$. For the critical value of k , sketch the phase portrait.
- Which kinds of behaviours could be critical values?

- 5 Consider the system of ODEs

$$\vec{r}'(t) = A\vec{r}(t).$$

Let $T = \text{trace}(A) = a_{11} + a_{22}$, $D = \det(A) = a_{11}a_{22} - a_{12}a_{21}$, and $\Delta = T^2 - 4D$.

- Show that the equilibrium solution is a saddle point if $D < 0$.
- Show that the equilibrium solution is a spiral if $\Delta < 0$ and $T \neq 0$.
- Show that the equilibrium solution is a centre if $T = 0$ and $D > 0$.
- When is the equilibrium point a node?
- Show that the equilibrium solution is asymptotically stable if $T < 0$ and $D > 0$.
- Show that the equilibrium solution is unstable if $T > 0$ and $D < 0$.

Consider the following model for cheetah's and lions, where

$$\vec{p}(t) = \begin{bmatrix} \ell(t) = \text{population of lions} \\ c(t) = \text{population of cheetahs} \end{bmatrix}$$

which satisfies

$$\frac{d\vec{p}}{dt} = \begin{bmatrix} 1 & -1 \\ -3 & 1 \end{bmatrix}$$

The general solution is:

$$\vec{p}(t) = c_1 \begin{bmatrix} 1 \\ \sqrt{3} \end{bmatrix} e^{(1-\sqrt{3})t} + c_2 \begin{bmatrix} -1 \\ \sqrt{3} \end{bmatrix} e^{(1+\sqrt{3})t}.$$

- 36.1 Without computing them, what are the eigenvalues and eigenvectors of the matrix?
- 36.2 Sketch the graph of the solution with $c_1 = \pm 1$ and $c_2 = 0$.
- 36.3 Sketch the graph of the solution with $c_1 = 0$ and $c_2 = \pm 1$.
- 36.4 When one constant is set to 0, what is the shape of the graph? Is it always like that? Can you prove it?
- 36.5 Sketch the graph of the solution with $c_1 = \pm 1$ and $c_2 = \pm 1$.
- 36.6 Provide an interpretation of the different types of solutions.

Let us expand the model from the previous exercise to:

$$\vec{p}(t) = \begin{bmatrix} \ell(t) = \text{population of lions} \\ c(t) = \text{population of cheetahs} \end{bmatrix}$$

which satisfies

$$\frac{d\vec{p}}{dt} = \begin{bmatrix} 1 & -1 \\ -3 & 1 \end{bmatrix} \vec{p} + \begin{bmatrix} -10 \\ 50 \end{bmatrix}.$$

The extra term corresponds to the effect of harvesting 10 lions and bringing in 50 cheetahs every year to the reserve.

The general solution is:

$$\vec{p}(t) = \begin{bmatrix} 20 \\ 10 \end{bmatrix} + c_1 \begin{bmatrix} 1 \\ \sqrt{3} \end{bmatrix} e^{(1-\sqrt{3})t} + c_2 \begin{bmatrix} -1 \\ \sqrt{3} \end{bmatrix} e^{(1+\sqrt{3})t}.$$

- 37.1 Sketch the phase portrait.
- 37.2 Provide an interpretation of the different types of solutions.

38

For each of the following general solutions, sketch the phase portrait.

38.1 $\vec{r}(t) = c_1 \begin{bmatrix} 2 \\ 1 \end{bmatrix} e^{2t} + c_2 \begin{bmatrix} -1 \\ 1 \end{bmatrix} e^{5t}.$

38.2 $\vec{r}(t) = c_1 \begin{bmatrix} 2 \\ 1 \end{bmatrix} e^{-2t} + c_2 \begin{bmatrix} -1 \\ 1 \end{bmatrix} e^{-5t}.$

Analysis of Models with Systems

In this module you will learn

- different ways to analyze models with several differential equations

In this chapter, we have learned how to create models involving systems of ODEs and how to solve some special types of systems of ODEs.

Once we create a model that involves a system of ODEs, the ultimate goal is not to solve the system of ODEs, but to be able to understand how the situation will develop. Solving the system of ODEs is often a large step in that direction, but it is more important to know how to interpret it in light of the original situation.

Sometimes, when we cannot find an explicit formula for the solution, it is still possible to study the system to find some properties and behaviours of the solutions.

In this module, we'll study one example using a few different methods.

Example. The goal here is not the modelling but the analysis of the model, so we will quickly explain the model.

We are going to model population versus cost of living in Toronto.

Consider the following functions

- $p(t)$ = Population of Toronto (GTA) in millions, t years since the beginning of 2015.
- $c(t)$ = Cost of living in Toronto (in thousands of dollars), t years since the beginning of 2015.
- Define a vector $\vec{x}(t) = \begin{bmatrix} p(t) \\ c(t) \end{bmatrix}$.

We assume that these two factors are related according to the following properties:

- In the absence of any migration, the population will decrease proportionally to the cost of living (with constant a);
- There are always people moving into Toronto independently of its current population or cost of living (with constant b)
- In the absence of any other factors, the cost of living; increases proportionally to the population (with constant d)
- In the absence of any other factors, the cost of living; increases proportionally to the cost of living due to inflation (with constant e);
- The city is always expanding, so the cost of living is always decreasing independently of its current population or cost of living (with constant f).

The constants a, b, d, e, f are all positive.

Our model is:

$$\vec{x}'(t) = \begin{bmatrix} 0 & -a \\ d & e \end{bmatrix} \vec{x}(t) + \begin{bmatrix} b \\ -f \end{bmatrix}$$

Qualitative evolution of quantities

We can try to figure out how these quantities, $p(t)$ and $c(t)$, are going to increase or decrease.

As an academic example, let us imagine that initially $p(0) = c(0) = 0$.

Then, at $t = 0$, we have

$$p'(0) = b > 0 \quad \text{and} \quad c'(0) = -f < 0.$$

This means that $p(t)$ is increasing while $c(t)$ wants to decrease.

Here we need to make sure that everything still makes sense: since it doesn't make sense to have a negative cost of living (government incentives to move into the city?!), we need to disregard our system and assume that $c(t)$ will continue constant while $c'(t) < 0$.

We then have:

t	0							$+\infty$
p	0	↗						
c	0	→	0					

While $c(t) = 0$, we have

$$p'(t) = b > 0 \quad \text{and} \quad c'(t) = dp(t) - f.$$

This means that $p(t)$ is increasing with constant slope (linearly) until $c'(t_1) = 0$. We can figure out when this will happen:

$$0 = c'(t_1) = dp(t_1) - f \quad \Leftrightarrow \quad p(t_1) = \frac{f}{d}.$$

So we continue our table:

t	0		t_1					$+\infty$
p	0	↗	$\frac{f}{d}$					
c	0	→	0					

What happens after t_1 ?

Consider $t > t_1$ slightly after t_1 . Then

$$\begin{cases} p'(t) = -ac(t) + b > 0 & \text{still positive because } c(t) \text{ is very small, but the slope is decreasing} \\ c'(t) = dp(t) + ec(t) - f > 0 & \text{increasing quickly as both } p \text{ and } c \text{ increase} \end{cases}$$

t	0		t_1					$+\infty$
p	0	↗	$\frac{f}{d}$	↘				
c	0	→	0	↘				

At a certain time t_2 , the population will stop increasing. Let us find out when this happens:

$$0 = p'(t_2) = -ac(t_2) + b > 0 \quad \Leftrightarrow \quad c(t_2) = \frac{b}{a}.$$

t	0		t_1		t_2			$+\infty$
p	0	↗	$\frac{f}{d}$	↘	→			
c	0	→	0	↘	$\frac{b}{a}$			

After this point we have $t > t_2$ slightly after t_2 :

$$\begin{cases} p'(t) = -ac(t) + b < 0 & \text{decreasing rapidly while } c'(t) > 0 \\ c'(t) = dp(t) + ec(t) - f > 0 & \text{still increasing quickly until } p(t) = 0 \end{cases}$$

We expect that at some point $p(t_3) = 0$. From that point on we have

$$\begin{cases} p'(t_3) = -ac(t_3) + b < 0 & \text{we need to ignore the model at this point and keep } p \text{ constant} \\ c'(t_3) = ec(t_3) - f > 0 & \text{still increasing exponentially, as long as } c(t_3) > \frac{f}{e} \end{cases}$$

So this is our final table:

t	0		t_1		t_2		t_3	$+\infty$
p	0	\nearrow	$\frac{f}{d}$	\curvearrowright	\rightarrow	\curvearrowleft	0	\rightarrow
c	0	\rightarrow	0	\curvearrowright	$\frac{b}{a}$	\curvearrowright		\curvearrowright

Observe that to do this analysis, we didn't need to know how to solve the system of ODEs.

Finding the equilibrium point(s)

This is often easy to find, and by using the intuition we gained while learning to sketch phase portraits, this can give us a lot of insight about the solutions.

Let us find the equilibrium point:

$$\begin{cases} 0 = p'(t) = -ac(t) + b \\ 0 = c'(t) = dp(t) + ec(t) - f \end{cases} \Leftrightarrow \begin{cases} c(t) = \frac{b}{a} \\ p(t) = \frac{af - be}{ad} \end{cases}$$

Observe that if the population and cost of living are at these levels, then they will remain constant.

This also informs us that the disastrous scenario on the first analysis, where the population all left the city, might have been caused by the starting position.

Interpreting the phase portrait

We have seen in the last module how to sketch a phase portrait for a system of ODEs such as this one.

Let us assume that the constants $a = b = d = e = 1$, $f = 2$. Then the phase portrait is

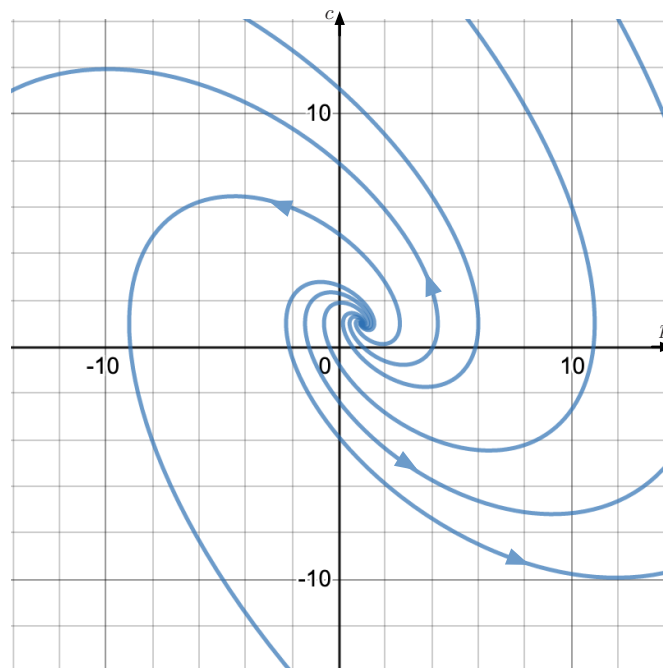

Observe that both quantities should be positive, so let us focus on the quadrant where both are positive:

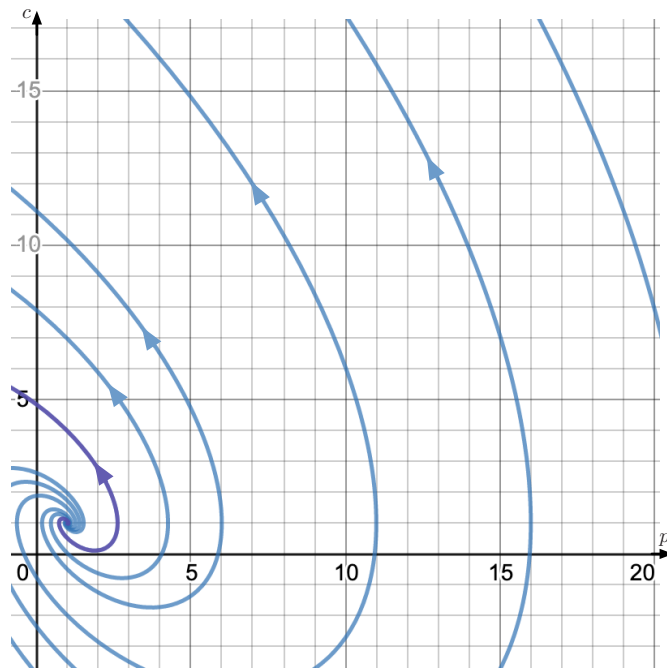

Observations:

- Whenever a graph hits the axes, we must stop the model and re-evaluate what that means: when the graph hits the $c = 0$ axis, then the population will start increasing until $c' > 0 \Leftrightarrow p = 2$, so the graph will continue horizontally until the point $(2, 0)$ where the model restarts.
- The population seems to converge to 0 in all cases.
- The purple case seems to be an interesting one where the population and cost of living oscillate for a bit near the equilibrium and then the cost of living goes almost to zero before starting to go up again and forcing all the people to leave the city.

Properties of the system

We can look for other properties of the system of ODEs.

Based on the two analyses above, we can ask the following question:

- Is there a value for the cost of living such that if it is above that, then eventually all the population will leave the city?

We know that

$$p'(t) = -ac(t) + b < 0 \quad \Leftrightarrow \quad c(t) > \frac{b}{a}.$$

So as long as the cost of living is above $\frac{b}{a}$, then the population will continue to decrease.

Observe that depending on the constants d, e, f , we could still have

$$c'(t) = dp(t) + e\frac{b}{a} - f < 0,$$

so that we could end up with a cycle around the equilibrium we found before.

Practice Problems

1 Consider the model for student learning:

- $\vec{x} = \begin{bmatrix} x_1 \\ x_2 \end{bmatrix}$
- x_1 = student confidence in his/her own abilities ($x_1 \in [0, 1]$)
- x_2 = student knowledge measured in IQ past 100
- $\vec{x}'(t) = \begin{bmatrix} a & b \\ c & -d \end{bmatrix} \vec{x}(t) + \begin{bmatrix} -e \\ 0 \end{bmatrix}$
- Constants $a, b, c, d, e > 0$.

- (a) What is the equilibrium solution \vec{x}_e ?
- (b) If tests are harder, then d is larger. How does that affect the equilibrium confidence and knowledge of students?
- (c) Is the equilibrium solution stable?
- (d) Assume $a = 1, b = c = 2, d = 3, e = 0$. As $t \rightarrow +\infty$, what are the possible outcomes for $\vec{x}(t)$ Explain the meaning for the students.
- (e) Assume $a = 1, b = c = 2, d = 3, e = 0$. Some solutions satisfy $\lim_{t \rightarrow +\infty} \begin{bmatrix} c(t) \\ k(t) \end{bmatrix} = \begin{bmatrix} +\infty \\ +\infty \end{bmatrix}$. Show on a graph which initial conditions $\vec{x}(0) = \begin{bmatrix} c(0) \\ k(0) \end{bmatrix}$ guarantee this limit?
- (f) If the tests become harder, i.e., d increases, then is that good or bad for students?.

2 Consider the model for a tree:

- $\vec{x}(t) = \begin{bmatrix} \ell(t) \\ h(t) \end{bmatrix}$
- $\ell(t)$ = area of leafs on the tree
- $h(t)$ = height of the tree
- $\vec{x}'(t) = \begin{bmatrix} a & -b \\ c & -d \end{bmatrix} \vec{x}(t)$
- Constants $a, b, c, d > 0$.

- (a) Is it possible to have the tree growing taller and taller forever while the leaf area remains bounded?
- (b) What would happen to the tree if the area of leafs is proportional to the height squared (not square root)?
- (c) If $ad = bc$, explain what happens to the tree as $t \rightarrow \infty$.

3 Consider the model of a car:

- $\vec{c}(t) = \begin{bmatrix} v(t) \\ f(t) \end{bmatrix}$
- $v(t)$ = speed of the car
- $f(t)$ = amount of fuel in the car's tank
- $\vec{c}'(t) = \begin{bmatrix} -2 & 1 \\ -2 & 0 \end{bmatrix} \vec{c}(t) + \begin{bmatrix} 0 \\ -1 \end{bmatrix}$

- (a) What is the equilibrium solution \vec{c}_{eq} ? What is the meaning of your result?
- (b) If the car runs out of fuel at 300 m/s, then describe what happens to the car.

(c) Describe what happens to the car when it starts at rest with a full tank of 300 L.

(d) If the car attains its maximum velocity when there are still 300 L of fuel left, what was the car's maximum velocity?

4 Consider the model for crying babies:

- $\vec{c}(t) = \begin{bmatrix} a(t) \\ b(t) \end{bmatrix}$
- $a(t)$ = volume of baby A's cries in dB
- $b(t)$ = volume of baby B's cries in dB
- $\vec{c}'(t) = \begin{bmatrix} -\alpha & \beta \\ \beta & -\alpha \end{bmatrix} \vec{c}(t)$
- constants $\alpha, \beta > 0$.

The constants α and β are 1 and 2. Does it make a difference which is 1 and which is 2?

Consider the following model for the sales from a designer clothing brand:

- $x_1(t)$ = purchases by “common mortals” (CM) at time t in years since the beginning of 2015.
- $x_2(t)$ = purchases by “famous people” (FP) at time t .

Our model is based on the following two principles:

(P_1) CM will buy more items from the brand when CM or FP buy more.

(P_2) FP will buy less when CM buy them, but will buy more when FP buy it.

The model we considered is:

$$\vec{x}'(t) = \begin{bmatrix} a & b \\ -c & d \end{bmatrix} \vec{x}(t)$$

- 39.1 Suppose that at the beginning only CM buy this brand. Describe how $x_1(t)$ and $x_2(t)$ evolve as $t > 0$.
- 39.2 Suppose that at the beginning only FP buy this brand. Describe how $x_1(t)$ and $x_2(t)$ evolve as $t > 0$.
- 39.3 What conditions on the constants a, b, c, d will guarantee that the solutions will spiral? In that case, is it a spiral source or spiral sink? Is it clockwise or counterclockwise?
- 39.4 Are there constants $a, b, c, d > 0$, such that the solution \vec{x} is periodic?
- 39.5 Consider the constants $a = b = c = d = 1$. Assume that initially CM were buying $c_0 > 0$ items and FP were buying $f_0 > 0$ items. What will happen to $x_1(t)$ and $x_2(t)$ as $t \rightarrow \infty$? Explain the results in terms of the evolution of purchases from CM and FP.
- 39.6 Consider the constants $a = b = c = d = 1$. If $c_0 = 10$, $f_0 = 100$, then at what time will FP stop buying items? And at what time will FP be buying the maximum number of items?

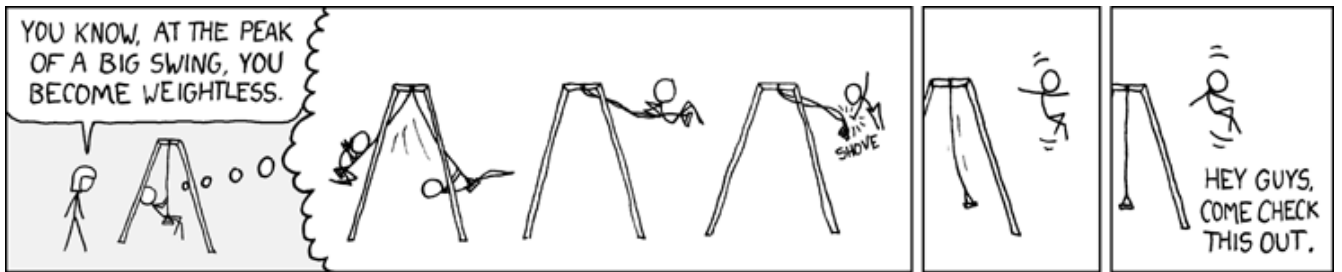

(image from xkcd - comic #226)

Modelling with Second-Order ODEs

In this module you will learn

- how to model physical phenomena to obtain second-order ODEs

Whenever we model the movement of objects, we often find ourselves using **Newton's Second Law of motion**:

Newton's Second Law of Motion. $F = m \cdot a$, where a is the acceleration of the object, m is its mass, and F is the net force acting on the object.

Because this “Law” includes the acceleration of the object, and we know that

$$\text{acceleration} = a = \frac{d(\text{velocity})}{dt} = \frac{dv}{dt} = \frac{d^2(\text{position})}{dt^2} = \frac{d^2r}{dt^2},$$

we will often end up with a Second-Order ODE.

Just like we did in module 19, we will follow the step by step procedure developed in chapter 1.

Step 1. Define the problem

Example.

We want to model the position of an object attached to the end of a spring.

The first step is to decide on what we want to find at the end of the process. So we define:

- $y(t)$ = the vertical position of the mass, where $y = 0$ is the position of the mass at rest.

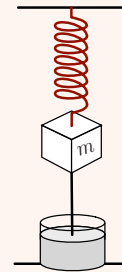

Step 2. Build a mind map

Example. We start with the mass and then we brainstorm about the things that affect the mass:

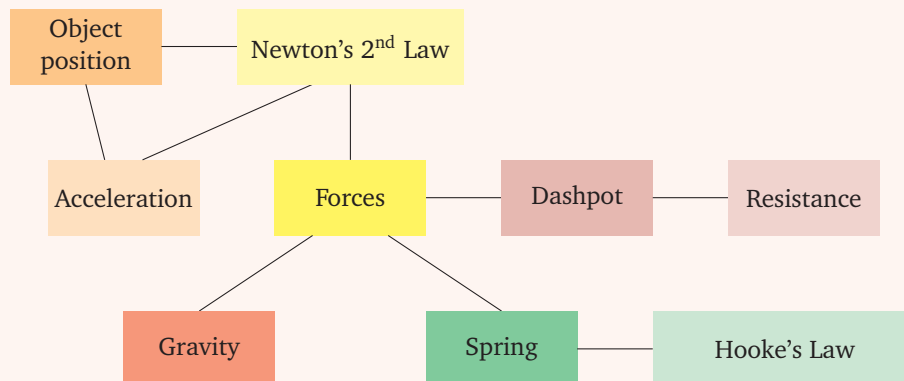

Step 3. Make assumptions

Example. In this step, we discuss the mind map we created and how we plan to address each of the boxes, or only some of the boxes. This will involve making assumptions and providing an explanation to the assumptions we make.

1. As we described before the example, the plan is to use Newton's Second Law of Motion to describe

the motion of the mass. This involves three quantities:

- mass: we assume that this is known to the modeller;
- acceleration: as we mentioned above, this is directly related to the position of the object. We have $y''(t) = \text{acceleration}$, as long as we are assuming that the object is moving only vertically;
- forces: we need to find all the forces acting on the object and add them.

The forces acting on the object need to be discussed separately:

- Gravity: we will go on a limb here and say that the force of the spring is much larger, so we will ignore this force;
- Spring: the force of the spring that acts on the mass follows Hooke's Law that says that the force is proportional to the extension/contraction of the spring. The constant of proportionality depends on the spring and we assume that it is known;
- Dashpot: the dashpot provides resistance. We will assume that it provides linear resistance to movement: the force is proportional to the velocity, with a proportionality constant that depends on the dashpot and is assumed to be known to the modeller.

Step 4. Construct a model

Example. We will start with Newton's Second Law of motion:

- $my''(t) = F(t)$

and we will add the different forces one by one:

- Spring: the force of the spring is $-ky(t)$; (you should check that the sign makes sense)
- Dashpot: the force of the dashpot is $-\gamma y'(t)$. (you should also check the sign of this term)

Right now we have the following model:

$$my''(t) = -ky(t) - \gamma y'(t).$$

Step 5. Model assessment

We'll skip this part here, but you should try to develop some tests to check the validity of the model we came up with. Specifically, the fact that we ignored gravity should be checked to make sure that it doesn't affect our model too much.

Practice Problems

1 Consider a mountain with shape $y = f(x)$ a hiker who is climbing down the mountain with horizontal position $x(t)$. She starts at a peak of the mountain at $x_0 = 0$. As she climbs down the mountain, she notices that from her point-of-view, the rate of change of the slope of the mountain is decreasing linearly with time. The hiker also notices that her horizontal speed is constant.

Model the hiker's position and the shape of the mountain.

- 2 Model a ping pong ball travelling through the air.
- 3 Model an old TV floating or sinking in the ocean.
- 4 Model a container floating in the ocean with a leak that allows water to get inside.

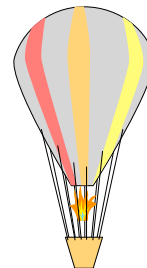

- 5 Model a hot air balloon flying through the air.
- 6 Imagine a cylinder floating vertically partially submerged in a lake. Model the position of its top.
- 7 Model a ball rolling down a hill.
- 8 Model an electric circuit with a resistor, and inductor, and a capacitor in series.

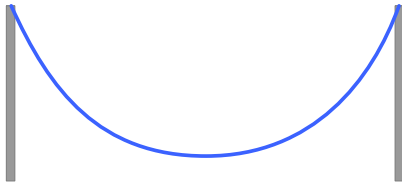

9 Model the shape of a rope hanging between two poles.

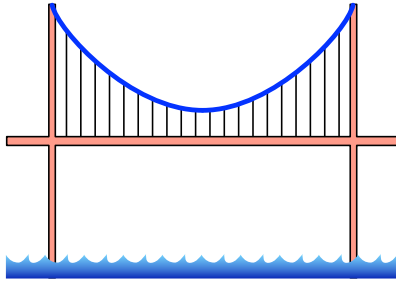

- 10 Model the shape of the cables of a suspension bridge.
- 11 Start with the Law of Conservation of Energy and assume a conservative force. Then show that you obtain Newton's Second Law of motion.
- 12 Model a self-balancing device, like a segway or a onewheel.
- 13 Imagine a device that can turn the handlebar of a bicycle. Model how it should act to keep the bicycle upright.

40

Here are some facts about laptop keys:

- (da) Each key must also include some damping, so that it doesn't keep oscillating back and forth once pressed.
- (di) A typical letter key is $15\text{mm} \times 15\text{mm}$ and when pressed has a maximum displacement of 0.5mm .
- (fo) On average, a person exerts the force of 42N with one finger on a key.
- (gr) Gravity is much weaker than the spring that keeps the key in place.
- (hl) Each key has a spring to make the key return to its original position after being pressed (Hooke's Law: "the force is proportional to the extension").
- (lo) Keys last 50 million presses on average.
- (ve) Keys can only move vertically.

40.1 Model a laptop keypress.

40.2 What happens if the damping system of the key is broken? What happens if the damping system is too strong? How strong should the damping system be?

40.3 What happens to the key when the spring breaks?

41 Model a ball rolling down a ramp.

Second-Order Linear ODEs with Constant Coefficients

In this module you will learn

- how to solve this type of ODEs

In this module we will learn how to solve a specific type of Second-Order ODEs: linear second-order ODEs with constant coefficients. These equations have the form

$$ay''(t) + by'(t) + cy(t) = f(t).$$

4.1 Homogeneous ODEs

These are ODEs above with $f(t) \equiv 0$. So we are trying to solve

$$ay''(t) + by'(t) + cy(t) = 0.$$

The main idea to solve these problems is the same as for systems: making an **educated guess** that the solution should look like an exponential:

$$y(t) = e^{rt},$$

and we need to find which values of r yield solutions.

We do that by plugging this formula for $y(t)$ into the ODE:

- $y'(t) = re^{rt}$
- $y''(t) = r^2e^{rt}$

We get

$$ar^2e^{rt} + bre^{rt} + ce^{rt} = 0 \quad \Leftrightarrow \quad ar^2 + br + c = 0.$$

This equation for r is called the **characteristic equation**.

We know how to solve it:

$$r = \frac{-b \pm \sqrt{b^2 - 4ac}}{2a}.$$

That means that we have three possible cases.

Two real distinct roots. When $b^2 - 4ac > 0$, we have two possible values for r that are real numbers: r_1 and r_2 .

Then, similarly to what we did with systems of ODEs, we obtain two solutions

$$y_1(t) = e^{r_1 t} \quad \text{and} \quad y_2(t) = e^{r_2 t},$$

and the general solution is

$$y(t) = c_1 e^{r_1 t} + c_2 e^{r_2 t}.$$

Video.

- https://youtu.be/_8fcT95JV34



■ https://youtu.be/nE_OnX8ulHA



■ <https://youtu.be/v1xKZ0rGsVc>



Two complex roots. When $b^2 - 4ac < 0$, we have two possible values for r , but they are complex values:

$$r_{\pm} = \alpha \pm i\beta.$$

What are the value of α and β ?

Then we have two solutions

$$y_+(t) = e^{(\alpha+i\beta)t} \quad \text{and} \quad y_-(t) = e^{(\alpha-i\beta)t},$$

and the general solution is

$$y(t) = a_1 e^{(\alpha+i\beta)t} + a_2 e^{(\alpha-i\beta)t}.$$

Just like we did with systems with complex eigenvalues, we prefer to write the solutions without complex numbers, so we expand it using Euler's formula to get

$$\begin{aligned} y(t) &= a_1 e^{(\alpha+i\beta)t} + a_2 e^{(\alpha-i\beta)t} \\ &= a_1 e^{\alpha t} e^{i\beta t} + a_2 e^{\alpha t} e^{-i\beta t} \\ &= a_1 e^{\alpha t} (\cos(\beta t) + i \sin(\beta t)) + a_2 e^{\alpha t} (\cos(\beta t) - i \sin(\beta t)) \\ &= (a_1 + a_2) \cos(\beta t) e^{\alpha t} + i(a_1 - a_2) \sin(\beta t) e^{\alpha t} \\ &= c_1 \cos(\beta t) e^{\alpha t} + c_2 \sin(\beta t) e^{\alpha t} \end{aligned}$$

How do c_1 and c_2 depend on a_1, a_2 ?

So another way to write the general solution is

$$y(t) = c_1 \cos(\beta t) e^{\alpha t} + c_2 \sin(\beta t) e^{\alpha t}.$$

Video.

■ <https://youtu.be/DOR16GMPtjM?t=396>



One real repeated root. When $b^2 - 4ac = 0$, then we are left with only one value for $r = -\frac{b}{2a}$.

We then have one solution

$$y_1(t) = e^{-\frac{b}{2a}t}.$$

Example. Consider the ODE

$$y''(t) + 2y'(t) + y(t) = 0.$$

To find the general solution, we assume that the solutions have the form $y(t) = e^{rt}$, which means that r must satisfy

$$r^2 + 2r + 1 = 0 \quad \Leftrightarrow \quad r = -1,$$

so $y_1(t) = c_1 e^{-t}$.

Now can we solve this ODE with the following initial conditions?

- $y(0) = 2$ and $y'(0) = -2$.
- $y(0) = 2$ and $y'(0) = 1$.

This previous example, should give a good idea on why having one value for r means that we are missing something. We need to find a second solution $y_2(t)$.

If we want to find all the divisors of 42, and we already know that $d_1 = 2$ is a divisor, then we can use the divisor d_1 we know to write

$$d_1 \cdot x = 42 \iff 2x = 42 \iff x = 21,$$

where x is the product of all the other divisors.

We used the divisor we knew d_1 to obtain a simpler problem for the other divisors.

Reduction of Order. The idea here is the same. We use the solution we found to try to obtain a simpler ODE for the other solution:

$$y(t) = y_1(t) \cdot u(t),$$

where $y(t)$ is the solution we are still missing, $y_1(t)$ is the solution we already found, and $u(t)$ is a function. If we find $u(t)$, then we find $y(t)$. We hope that the function $u(t)$ satisfies a simpler problem.

To do that, we need to plug the formula above for $y(t)$ into the original ODE.

Important. You should do these calculations yourself. Remember to use the product rule and to be careful not to make any mistakes.

Also remember that we know the value of r .

We obtain

$$u''(t) = 0 \iff u(t) = c_1 + c_2 t.$$

This means that we found

$$y(t) = (c_1 + c_2 t)e^{rt} \iff y(t) = \underbrace{c_1 e^{rt}}_{\text{previous solution } y_1(t)} + c_2 t e^{rt}.$$

The general solution is

$$y(t) = c_1 e^{rt} + c_2 t e^{rt},$$

where $r = -\frac{b}{2a}$.

Video.

- <https://youtu.be/DOR16GMPtjM>



4.2 Non-Homogeneous ODEs

We are trying to solve

$$ay''(t) + by'(t) + cy(t) = f(t), \quad (*)$$

where $f(t)$ is a known function.

Important. If $u(t)$ is the general solution of

$$ay''(t) + by'(t) + cy(t) = 0, \quad (H)$$

and $v(t)$ satisfies

$$ay''(t) + by'(t) + cy(t) = f(t), \tag{*}$$

then $y(t) = u(t) + v(t)$ gives the general solution of

$$ay''(t) + by'(t) + cy(t) = f(t).$$

This is a practice problem at the end of this module.

This means that to solve this ODE, we split the general solution into two parts

$$y(t) = y_c(t) + y_p(t),$$

where

- $y_c(t)$ is called the **complementary solution** and it is the general solution of the corresponding homogeneous ODE (H). It is solved using the technique we studied above.
- $y_p(t)$ is called the **particular solution** and it is one function that satisfies the original ODE (*).

Important. It may seem strange that to solve the original ODE, we need its solution, but what we are trying to do is find **all possible solutions** of the original ODE.

To find all possible solutions of the original ODE, we require two things:

- **One** solution of the original ODE: $y_p(t)$,
- and all possible solutions of the homogeneous ODE: $y_c(t)$.

We already know how to find the complementary solution, so we will focus our attention on finding one particular solution.

Method of Undetermined Coefficients. As you probably have gotten used to by now, this is a method of educated guess-and-check.

Let us look at the equation from a different point-of-view

$$ay''(t) + by'(t) + cy(t) = f(t)$$

linear combination of
function and derivatives = $f(t)$

and remember that some functions don't change much when differentiated:

- Exponentials $y = ce^{rt}$ don't change their form after differentiation $y' = cre^{rt} = de^{rt}$. They even keep the same exponential term.
- Polynomials don't change their form either: their derivative is also a polynomial, with lower degree.
- Cosines and Sines alternate between one and the other, so functions of the form $y = c_1 \sin(rt) + c_2 \cos(rt)$ don't change after differentiation.

Important. This means that, if $f(t)$ is one of these types of function, then $y(t)$ must be of the same form.

Example. Find a particular solution for the ODE

$$y'' - 4y = 10e^{3t} = (\text{constant}) \cdot (\text{exponential of } 3t).$$

Our candidate is

$$y_p(t) = Ae^{3t}.$$

Now we need to find the constant A by plugging it into the ODE:

$$9Ae^{3t} - 4 \cdot Ae^{3t} = 10e^{3t} \iff A = 2,$$

so $y_p(t) = 2e^{3t}$ is a particular solution.

Example. Find a particular solution for the ODE

$$y'' - 4y = 3t^2 + 2t = (\text{polynomial of degree 2}).$$

Our candidate is

$$y_p(t) = At^2 + Bt + C.$$

Now we need to find the constants A, B, C by plugging the formula for y_p into the ODE:

$$2A - 4At^2 - 4Bt - 4C = 3t^2 + 2t \Leftrightarrow \begin{cases} A = -\frac{3}{4} \\ B = -\frac{1}{2} \\ C = \frac{A}{2} = -\frac{3}{8}. \end{cases}$$

so $y_p(t) = -\frac{3}{4}t^2 - \frac{1}{2}t - \frac{3}{8}$ is a particular solution.

There are some more details to deal with when using this method that will be addressed in the core exercises.

Video.

■ <https://youtu.be/CjZ0TfPnWVU>

■ <https://youtu.be/ubdSxJ2nmVk>

■ <https://youtu.be/YRvqem1n0nQ>



Practice Problems

1 Find the complementary and particular solutions for the following ODEs

- (a) $y'' - 2y' - 3y = 3e^{2t}$
- (b) $y'' - 2y' - 3y = -3te^{-t}$
- (c) $y'' - 9y = t^2e^{-3t} - 6$
- (d) $y'' + 2y' - 8y = e^{-t} - 2e^t$
- (e) $y'' - y' - 6y = \sin(t)$
- (f) $y'' - y' - 6y = \sin(t) + 3e^{3t}$
- (g) $y'' + 4y = (2t + 1)\sin(t) + 4\cos(2t)$
- (h) $y'' + y = \cos(2t) + t^3$
- (i) $y'' - y' - 2y = t \cos(t) - t \sin(t)$
- (j) $y'' + 5y' + 6y = 2e^{-2t}$

2 What is the form of the particular solution for the ODE

$$y^{(6)} + y^{(5)} - 5y^{(4)} + 31y''' - 176y'' + 220y' = (3t-1)e^{2t} + t^3e^{-5t} \sin(3t) + (4t^2-2t)e^{-2t} \sin(3t),$$

knowing that

$$x^6 + x^5 - 5x^4 + 31x^3 - 176x^2 + 220x = ((x^2 + 2) + 9) * (x - 2)^2 * x * (x + 5) ?$$

3 What is the form of the particular solution for the ODE

$$y'''' - 4y''' + 10y'' - 12y' + 5y = te^t + t^2 \cos(2t) - (2t + 1)e^t \sin(t),$$

knowing that

$$x^4 - 4x^3 + 10x^2 - 12x + 5 = (x - 1)^2((x - 1)^2 + 4) ?$$

4 Consider the ODE

$$t^2y'' + ty' - 9y = 0,$$

and a solution $y_1(t) = t^3$.

(a) Use the reduction of order technique to deduce the general solution to this problem.

Hint. You should find a second-order ODE for $u(t)$ without the term $u(t)$. So define $v(t) = u'(t)$ and solve the first-order ODE for $v(t)$.

(b) Find the solution with initial conditions $y(1) = 1$ and $y'(1) = -3$.

- (c) Find the solution with initial conditions $y(1) = 1$ and $y'(1) = 3$.
- (d) Find the solution with initial conditions $y(1) = 1$ and $y'(1) = 0$.

5 Consider the ODE

$$t^2 y'' - 3t y' + 4y = 0$$

and a solution $y_1(t) = t^2$.

- (a) Use the reduction of order technique to deduce the general solution to this problem.
 - (b) Find the solution with initial conditions $y(1) = 1$ and $y'(1) = 2$.
 - (c) Find the solution with initial conditions $y(1) = 0$ and $y'(1) = 1$.
- 6 Consider the ODE $ay'' + by' + cy = f(t)$, with complementary solution $y_c(t) = c_1 y_1(t) + c_2 y_2(t)$ and particular solution $y_p(t)$.

Consider also the initial conditions $y(0) = y_0$ and $y'(0) = v_0$.

Show that there exist constants c_1, c_2 such that $y(t) = y_c(t) + y_p(t)$ solves the ODE with these initial conditions.

42 Consider the ODE $y''(t) - 9y(t) = f(t)$.

42.1 Find a complementary solution.

42.2 Find a particular solution for $f(t) = 14e^{-4t}$.

42.3 Find a particular solution for $f(t) = 9e^{-3t}$.

42.4 Find a particular solution for $f(t) = 10 \cos(t)$.

43 Consider the ODE $y''(t) - 2y'(t) + 5y(t) = f(t)$.

43.1 Find a complementary solution.

43.2 Find a particular solution for $f(t) = \sin(2t)e^t$.

43.3 Find a particular solution for $f(t) = (4t + 2)\sin(2t)e^t$.

44 Consider the ODE $y'' + 3y' = 3t$.

44.1 Find the complementary solution.

44.2 Find a particular solution.

44.3 Find the solution that also satisfies

$$\begin{cases} y(0) = 0 \\ y'(0) = 0 \end{cases}$$

Analysis of Models with Higher Order ODEs

In this module you will learn

- different ways to analyze models with higher-order differential equations

In this chapter, we have learned how to create models involving systems of ODEs and how to solve some special types of second-order ODEs.

In this module, we'll study one example using a few different methods.

Example. Consider the model we found earlier for a mass attached to a spring:

- $y(t)$ = vertical position of the mass, where $y = 0$ is the position of the mass at rest
- $my''(t) = -ky(t) - \gamma y'(t)$
- $m, k, \gamma > 0$ are constants for the mass, the stiffness of the spring, and the resistance of the dashpot.

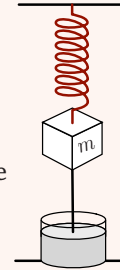

Qualitative evolution of quantities

We can try to figure out how these quantities, $y(t)$, $y'(t)$, and $y''(t)$ are going to increase or decrease as time goes by.

Let us imagine that initially $y(0) = 1, y'(0) = 0$.

Then, at $t = 0$, we have

$$\begin{cases} y(0) = 1 \\ y'(0) = 0 \\ y''(0) = -k < 0 \end{cases} \quad (\text{so object is decelerating, meaning speed will become negative})$$

This means that the object is decelerating, so we have two immediate consequences:

- the speed will decrease and become negative
- the position will start decreasing

Once the speed is negative, we see another effect

$$y''(t) = -k \underbrace{y(t)}_{\text{decreasing}} \underbrace{-\gamma y'(t)}_{\text{positive}}$$

so the acceleration is negative but approaching zero at time t_1 :

$$0 = y''(t_1) = -ky(t_1) - \gamma y'(t_1) \Leftrightarrow ky(t_1) = -\gamma y'(t_1)$$

Let us summarize our results so far in a table:

t	0		t_1				$+\infty$
y	1	↘	+	↘			
y'	0	↘	-	↗			
y''	-	↗	0	↗			

The next milestone is:

$$y(t_2) = 0 \quad \text{or} \quad y'(t_2) = 0.$$

If $y'(t_2) = 0$ while $y(t_2) > 0$, then

$$y''(t_2) = -ky(t_2) < 0,$$

which means that y'' would have had to decrease again, become zero and then negative, so there would have been another milestone before. We deduce that the next milestone is

$$y(t_2) = 0 \quad \Leftrightarrow \quad y''(t_2) = -\gamma y'(t_2) > 0.$$

t	0		t_1		t_2		t_3	$+\infty$
y	1	↘	+	↘	0	↘	-	...
y'	0	↘	-	↗	-	↗	0	...
y''	-	↗	0	↗	+	↗	+	...

We can continue this analysis to conclude that the position seems to cycle back and forth between positive and negative, like you would expect from a spring.

In fact, this *study is flawed*, since there is a possibility that the time t_1 never happens and the spring only approaches the state described without ever reaching it. This will happen for some configuration of the constants m, k, γ .

Properties of the solutions

We learned earlier in the chapter how to solve this type of differential equations.

To solve them, we assume that solutions are of the form $y = e^{rt}$ and then find a characteristic equation for r :

$$mr^2 = -k - \gamma r \quad \Leftrightarrow \quad r = \frac{-\gamma \pm \sqrt{\gamma^2 - 4mk}}{2m}.$$

Depending on the constants m, k, γ , we can have:

- Two real distinct solutions
- Two complex distinct solutions
- One repeated real solution

How do solutions behave in each case? What kind of springs or dashpots imply each case?

Limiting behaviour of the solutions

From the analysis done above, we see that the possible values for r are either negative or when r is complex, its real part is negative (why?).

This means that the solution will have the form

$$y(t) = e^{(\text{negative constant})t} [a \cos(\alpha t) + b \sin(\beta t) + c],$$

so

$$\lim_{t \rightarrow \infty} y(t) = 0.$$

This means that the mass will slow down and eventually stop.

Numerical approximations

In module 16 we learned how to approximate solutions of first-order ODEs using Euler's Method.

We can extend that method to second-order ODEs, which we will leave as an exercise, and approximate the solution:

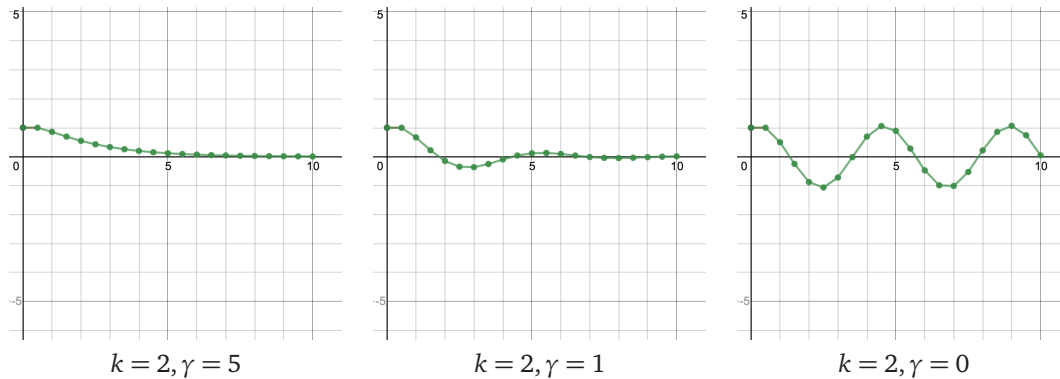

These graphs also give us some intuition on how the solutions behave.

You can access this simulation here:

■ <https://www.desmos.com/calculator/mufgdgku9w>



Practice Problems

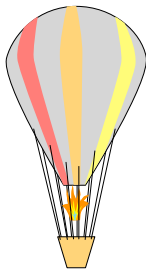

1 Consider the model for a hot air balloon:

- $y(t)$ = altitude of the balloon;
- $y''(t) = \underbrace{-g}_{\text{gravity}} + \underbrace{(g - 9(y - 1000))}_{\text{lift}} + p(t)$;
- g = gravitational constant;
- $p(t)$ = passenger actions affecting the vertical acceleration of the balloon.

- (a) What is the equilibrium altitude?
- (b) How does the balloon behave without passenger actions?
- (c) If the passenger actions are $p(t) = 6 \cos(\omega t)$, study how the constant ω changes the behaviour.

2 Consider the model for a cubic object floating/sinking in the ocean:

- $d(t)$ = depth of the object;
- $md''(t) = -mg - \gamma |d'(t)|d'(t) + Ar^3$;

- m = mass of the object;
- r = length of one side of the object;
- γ = water resistance constant;
- A = buoyancy constant (density of water minus density of object).

- (a) Does the object float or sink?
- (b) What is the terminal vertical velocity of the object?
- (c) Assume the constants $r = \frac{1}{2}m$, $m = 30\text{kg}$, $\gamma = 1\text{kg/m}$, $A = 300 \cdot 2^3\text{kg}/(\text{ms})^2$, and approximate $g \approx 10\text{m/s}^2$. Assume that the initial depth of the object is 0m (the surface of the ocean). What is the object's terminal velocity? Will it reach the bottom of the ocean?

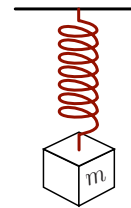

3 Consider the following model for a spring-mass system:

- $y(t)$ = position of the mass;
- $y''(t) = -ky(t) + f(t)$;
- k = stiffness of the spring;
- $f(t)$ = extra force on the mass.

- (a) How does the spring behave when there is no external force?
- (b) Assume $k = 9$. How does the spring behave when the external force is $f(t) = \cos(4t)$?
- (c) Assume $k = 9$. How does the spring behave when the external force is $f(t) = \cos(3t)$?
- (d) Assume $k = 9$. How does the spring behave when the external force is $f(t) = \cos(2.95t)$?

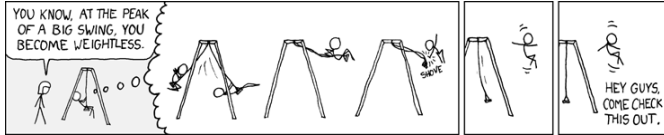

- 4 Explain how the initial statement of the comic makes sense.

Consider the second-order ODE:

$$y''(t) - 3y(t) = t(2 + \sin(t)).$$

- 45.1 Assume that $y(0) = 0$ and $y'(0) = b$. Which values of b guarantee that $y(t) > 0$ for $t \geq 0$.
- 45.2 Assume that $y(0) = a < 0$ and $y'(0) = b$. Give an example of a, b such that $y(t)$ is increasing for $t \geq 0$.
- 45.3 Assume that $y(0) = 0$ and $y'(0) = b$. Which values of b guarantee that $y(t) < 0$ for all $t > 0$.

Consider the second-order ODE:

$$\begin{cases} y''(t) + 4y(t) = f(t) \\ y(0) = y_0 \\ y'(0) = 0 \end{cases}$$

- 46.1 Let $f(t) = 0$ and $y_0 = 1$. Sketch the solution.
- 46.2 Let $f(t) = 396 \cos(20t)$ and $y_0 = 0$. Sketch the solution.
- 46.3 Let $f(t) = -4 \sin(2t)$ and $y_0 = 1$. Sketch the solution.
- 46.4 Let $f(t) = 0.39 \cos(1.9t)$ and $y_0 = 2$. Sketch the solution.

Hint. $\cos(at) + \cos(bt) = 2 \cos\left(\frac{a-b}{2}\right) \cos\left(\frac{a+b}{2}t\right)$



(image from xkcd - comic #947)

Introduction to Difference Equations

In this module you will learn

- what is a difference equation
- the different types of difference equations

Difference Equation. A *difference equation* is an equation involving a several terms of an unknown sequence.

Example.

1. $u_{k+1} = u_k + u_{k-1}$
2. $x_k = 2x_{k-1}$

Among difference equations, there are lots of types, that require different approaches, so we need to classify them.

Types of Differential Equations. Just like with differential equations, the main way we distinguish difference equations is according to:

- **order:** the order of a difference equation is the difference between the highest and the smallest terms of the sequence present in the difference equation;
- **linear** vs **nonlinear:** A difference equation $F(k, u_k, u_{k-1}, \dots, u_{k-n}) = 0$ is called **linear** if F is a linear function of $u_k, u_{k-1}, \dots, u_{k-n}$. Linear difference equations have the form

$$a_0(k)u_k + a_1(k)u_{k-1} + \dots + a_n(k)u_{k-n} = b(k).$$

All other differential equations are called **nonlinear**.

Roughly, to check whether a difference equation is **linear**, we need to check that:

- The unknown u_k and its other terms appear with exponent 1;
- The unknown u_k and its other terms do not multiply by each other;
- The unknown u_k and its other terms are not the objects of other functions – there are no occurrences of things like $\sin(u_k)$ or $e^{u_{k-4}}$, $\ln(u_{k+1})$, $\sqrt{u_{k-1}}$, etc.

Example.

1. The difference equation $u_k = 2u_{k-2}$ is linear and second-order, because $k - (k - 2) = 2$.
2. The difference equation $u_{k+1} = u_k^2 + u_{k-2}$ is nonlinear and third-order, because $(k + 1) - (k - 2) = 3$.

Similarly to differential equations, linear difference equations are, in general, easier to study and their theory is much more developed.

Solving Difference Equations

In this module you will learn

- how to solve some types of difference equations

Let us start with a technique that is very simple and useful, although because it is so simple, it requires some ingenuity to pull off in some cases.

23.1. Expanding to find a pattern

We'll start with an example.

Example. Consider the initial-value problem

$$\begin{cases} u_{k+1} = \frac{3}{2}u_k & \text{for } k \geq 0 \\ u_0 = 5 \end{cases}$$

Then we can start calculating:

- $u_1 = \frac{3}{2}u_0 = 7.5$
- $u_2 = \frac{3}{2}u_1 = 11.25$
- $u_3 = \frac{3}{2}u_2 = 16.875$
- $u_4 = \frac{3}{2}u_3 = 25.3125$
- $u_5 = \frac{3}{2}u_4 = 37.96875$
- \vdots

As you can notice, it's not particularly easy to find a pattern in these numbers.

The problem is that we *over-simplified*. The trick with this technique is to simplify without over-simplifying.

Let's calculate again:

- $u_1 = \frac{3}{2}u_0 = \frac{3}{2} \cdot 5$
- $u_2 = \frac{3}{2}u_1 = \frac{3}{2} \cdot \frac{3}{2} \cdot 5 = \left(\frac{3}{2}\right)^2 \cdot 5$
- $u_3 = \frac{3}{2}u_2 = \frac{3}{2} \cdot \left(\frac{3}{2}\right)^2 \cdot 5 = \left(\frac{3}{2}\right)^3 \cdot 5$
- $u_4 = \frac{3}{2}u_3 = \frac{3}{2} \cdot \left(\frac{3}{2}\right)^3 \cdot 5 = \left(\frac{3}{2}\right)^4 \cdot 5$
- $u_5 = \frac{3}{2}u_4 = \frac{3}{2} \cdot \left(\frac{3}{2}\right)^4 \cdot 5 = \left(\frac{3}{2}\right)^5 \cdot 5$
- \vdots

Now the pattern should be clear:

$$u_k = \left(\frac{3}{2}\right)^k \cdot 5.$$

To show that this is indeed the solution, we need to use Mathematical Induction (see appendix 7.2) to prove it.

The main idea of this technique is to calculate the terms of the fraction one by one in terms of the initial data. This is a technique that requires practice, as it is often difficult to judge which parts to simplify and which parts to expand to make sure the pattern emerges clearly.

Video.

■ <https://youtu.be/00cUAj0XmFc>

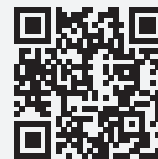

23.2. Educated Guessing

This is the technique we used several times in the book already. We used it with systems of differential equations and with second-order differential equations.

Observe that in the last example, the solution was an exponential, as was the case with differential equations.

Example. Consider the Fibonacci sequence:

$$\begin{cases} f_{k+1} = f_k + f_{k-1} \\ f_0 = 0 \\ f_1 = 1 \end{cases}$$

We want to find a formula for f_k . To do that, let us assume that the sequence is an exponential. So we can assume that

$$f_k = r^k,$$

for some value of r .

Let us now use this form of f_k into the difference equation to obtain:

$$r^{k+1} = r^k + r^{k-1},$$

which can be simplified by dividing by r^{k-1} :

$$r^2 = r + 1 \quad \Leftrightarrow \quad r^2 - r - 1 = 0.$$

This is a quadratic equation that we can solve:

$$r_{\pm} = \frac{1 \pm \sqrt{1+4}}{2} = \frac{1 \pm \sqrt{5}}{2}.$$

So we have two values of r that seem to work.

That is similar to what we had when solving second-order ODEs (and this is a second-order difference equation). In that case, the solution turned out to be a linear combination of the two solutions found:

$$f_k = c_1 r_-^k + c_2 r_+^k = c_1 \left(\frac{1 - \sqrt{5}}{2} \right)^k + c_2 \left(\frac{1 + \sqrt{5}}{2} \right)^k.$$

Now we need to find c_1 and c_2 using the initial data:

$$0 = c_1 + c_2 \quad (k = 0)$$

$$1 = c_1 \frac{1 - \sqrt{5}}{2} + c_2 \frac{1 + \sqrt{5}}{2} \quad (k = 1)$$

This yields:

$$c_1 = -\frac{1}{\sqrt{5}}$$

$$c_2 = \frac{1}{\sqrt{5}}$$

So the formula we obtain is

$$f_k = \frac{1}{\sqrt{5}} \left[\left(\frac{1 + \sqrt{5}}{2} \right)^k - \left(\frac{1 - \sqrt{5}}{2} \right)^k \right].$$

Important. The idea of this technique is to assume that the solution is an exponential of the form r^k and find the values for r that solve the particular difference equation. The general solution will be a linear combination of these solutions.

Video.

■ <https://youtu.be/A5tBvxDM9V4>



Practice Problems

1 Consider the initial-value problem

$$\begin{cases} x_{k+1} = 3x_k + 4 \\ x_0 = 1 \end{cases}$$

- (a) Using the expand-until-you-find-the-pattern technique, find the solution of this problem.
- (b) Observe that this problem has an equilibrium solution x^* . What is x^* ?
- (c) Define a new sequence $y_k = x_k - x^*$. Which initial-value problem does it satisfy?
- (d) Find y_k .
- (e) Find x_k .

2 Find the solution to the problem

$$\begin{cases} x_{k+1} = -2x_k + 3 \\ x_1 = 2 \end{cases}$$

3 When we were solving ODEs, we considered exponential solutions of the form $u_k = e^{rk}$, but above we considered $u_k = r^k$. Are these equivalent?

Consider the initial-value problem

$$\begin{cases} x_{k+1} = x_k - x_{k-1} \\ x_0 = 1 \\ x_1 = 2 \end{cases}$$

- (a) Solve the problem assuming the solution is of the form $u_k = r^k$.
- (b) Solve the problem assuming the solution is of the form $u_k = e^{rk}$.
- (c) What can you conclude?

4 Find the solution to the problem

$$\begin{cases} x_{k+1} = -2x_k - x_{k-1} \\ x_0 = 1 \\ x_1 = 2 \end{cases}$$

5 Find the solution for the problem

$$\begin{cases} ax_{k+1} - x_k + (1-a)x_{k-1} = 0 \\ x_0 = 1 \\ x_N = 0 \end{cases}$$

6 Consider the problem

$$x_k - 2x_{k-1} - x_{k-2} + 2x_{k-3} = 0$$

Find the solution for the following initial conditions.

- (a) $x_0 = 2, x_1 = 2, x_2 = 2$.
- (b) $x_0 = 1, x_1 = 0, x_2 = 1$.
- (c) $x_0 = 1, x_1 = 2, x_2 = 3$.

7 Consider the problem

$$\begin{cases} x_{k+1} = -2x_k - 2x_{k-1} \\ x_0 = 1 \\ x_1 = 0 \end{cases}$$

- (a) Find the solution of this problem (it will involve complex numbers).
- (b) Show that $x_k \in \mathbb{R}$ for all $k = 0, 1, \dots$

Let us re-write the solution without using complex numbers.

- (c) Assuming the solution is an exponential $x_k = r^k$, what are the possible values of r ?

This means that the solution is of the form

$$x_k = c_1 r_1^k + c_2 r_2^k.$$

We need to know how to easily write $\alpha + i\beta)^k$.

- (d) Using Euler's Formula in 3.2, write the complex numbers r_1 and r_2 in the form

$$r_1 = \rho e^{i\theta}.$$

Also show that

$$r_2 = \rho e^{-i\theta}.$$

- (e) Now it should be easier to compute r_1^k and r_2^k . After simplifying, use Euler's Formula in 3.2 again to get an expression for r_1^k with \cos and \sin .
- (f) Let us put everything together again to get a solution of the form

$$x_k = a_1 \rho^k \cos(?) + a_2 \rho^k \sin(?).$$

How do a_1, a_2 relate to c_1, c_2 ?

- (g) Find the constants a_1, a_2 .

47 Consider the difference equation

$$u_{k+1} = 6u_k - 9u_{k-1}$$

47.1 Find the solution that satisfies $u_0 = 1, u_1 = 3$.

47.2 Find the solution that satisfies $u_0 = 1, u_1 = 4$.

-
- 48 Consider a difference equation that has solutions $u_k = r^k$ for $r = 2$ and $r = 3$ and satisfies the conditions $u_0 = 7$ and $u_1 = 6$.
What is u_{22} ?

Modelling with Difference Equations

In this module you will learn

- when to model a quantity using a difference equation instead of a differential equation
- different ways to create a model using difference equations

In all the modelling scenarios of chapters 2, 3, and 4, we dealt with continuously changing quantities, and so the appropriate way to model these was through differential equations.

However, not everything changes continuously, some things change at specific time intervals. For those quantities, differential equations are not the best tool and we turn to difference equations.

This module will be divided in several parts depending on the type of situation.

24.1. Economic Models

Economic quantities often change in bursts, not continuously. That's what happens to a savings account as in the example below, or to stock prices, or to the balance left on a mortgage. Economic quantities are usually modelled by difference equations.

Example. We put a certain amount of money in a savings bank account with an annual interest rate of $p\%$, and compounded at regular periods of α (in years).

How does the balance in the savings account change over time?

Step 1. The goal is to model the balance on the account, so define

- $b(t)$ = balance on the savings account at time t .

Notice that the balance on the bank account doesn't change continuously, the balance doesn't change at all until the end of the compounding period. Then the bank adds the interest into the account.

So the balance only changes at each compounding period. We can change our goal to define

- b_n = balance on the savings account after n compounding periods.

Step 2. Create a mind map.

We will keep this model simple, so our mind map is just:



Step 3. Let us make the following assumptions:

- We make one initial deposit into the account at time $n = 0$.
- We don't make any more withdrawals or deposits.
- The only way the savings account balance changes is through the interest, which is the interest rate $p\%$ of the current balance.

Step 4. We create the following model

$$\begin{aligned} b_{n+1} &= \text{(previous balance)} + \text{interest} \\ b_{n+1} &= b_n + \alpha \frac{p}{100} b_n = \left(1 + \alpha \frac{p}{100}\right) b_n. \end{aligned}$$

24.2. Probability Models

There are several circumstances that involve probabilities that can be modelled using difference equations. Below is an example of one such circumstance.

Example.

A gambler plays a game at a casino. The game is played one round at a time. Each round, one of two things happens:

- The gambler wins \$1 with a probability of q
- The gambler loses \$1 with a probability of $1 - q$

The gambler will stop playing only if

- The gambler is ruined (bankrupt)
- The gambler reaches $\$W$.

What is the probability p_n that the player will be ruined if he starts gambling with $\$n$?

Step 2. Mind map.

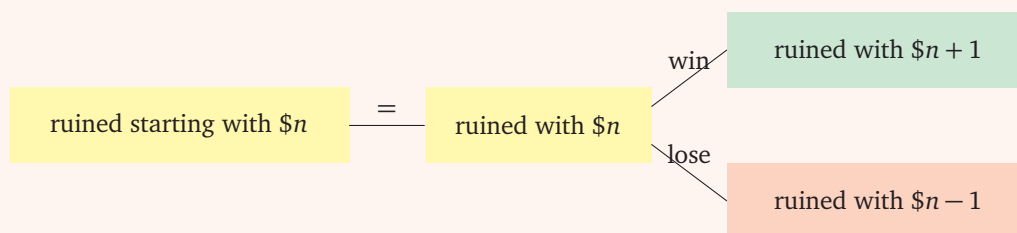

The two boxes on the left are very important. The crucial idea is to realize that it doesn't matter when the gambler has $\$n$. If s/he has $\$n$ at two different points in time, then the probability of becoming ruined is the same.

This mind map, shows us that we can relate p_n , p_{n+1} and p_{n-1} .

The rest of the modelling will be left as a practice problem.

Video.

- <https://youtu.be/Rr2iSK1engg>



24.3. Population Models

We have modelled populations using differential equations. Populations can be modelled using both differential or difference equations. Which kind of equations to use depends on the goal of the model and the assumptions that we make.

Below we'll see an example of a population model using difference equations.

Example.

Model a population of mosquitoes, who reproduce at specific times of the year.

Step 1. The goal is to model the population, so we define

- $p(t)$ = population of mosquitoes at time t .

Step 2. We create a mind map for this problem.

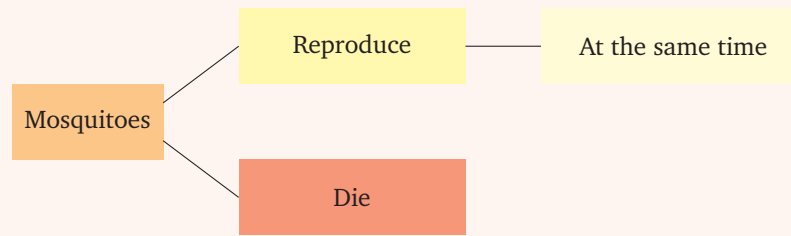

Step 3. Given that the mosquito population all reproduces at the same time, we don't need to track the population at all times t .

So we can assume that the mosquito population doesn't change (much) between seasons, and we change our objective function from $p(t)$ to p_n :

- p_n = population of mosquitoes at the beginning of season n .

We understand that mosquitoes die in between seasons, but in this model, we only count the deaths at the beginning of each season.

The next assumption is that the number of nymphs (baby mosquitoes) is proportional to the number of mosquitoes in the beginning of the season.

Similarly, the number of deaths is proportional to the number of mosquitoes in the beginning of the season.

Also observe that mosquitoes only live for one season, which means that the proportionality constant $\mu > 1$.

Step 4. So our model is

- p_n = population of mosquitoes at the beginning of season n .
- $p_{n+1} = rp_n - \mu p_n = (r - \mu)p_n$;
- r = the average number of nymphs per per mosquito per season;
- μ = the average number of deaths per mosquito per season;
- $\mu > 1$, which means that each mosquito itself dies (at the end of the seasons if not earlier), but also some of its nymphs will die.

Video.

- https://youtu.be/j__Kredt7vY

- <https://youtu.be/qmm9GPhA1MY>

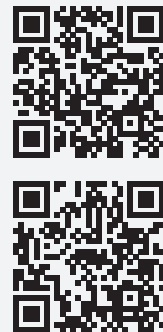

Practice Problems

Create a model for the following situations.

- 1 You just took a loan to buy a car. You'll need to make fixed payments every period, and the bank will charge an interest on the amount you still owe every period.

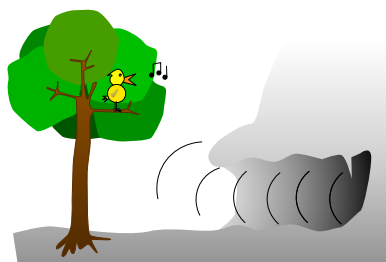

- 2 A bird is chirping to find a mate. Unfortunately it is standing next to a cave which echoes its chirps. Consider the following:

- (P₁) The bird chirps once every minute;
- (P₂) The maximum volume the bird can chirp is M dB;
- (P₃) If it hears a chirp, then it chirps at a volume proportional to the volume of the chirp it heard times the difference between the maximum volume it is capable and the volume heard with constant $A \frac{1}{dB}$;

- 3 IBM just developed a new software that they wish to charge for usage. In this program, there is a parameter n that you can choose to change how it performs:

- n^2 = number of operations it takes to run the program;
- The profit IBM will make is $-\ln(\text{error})$ in Canadian dollars (negative means that IBM has to pay a penalty).

Model the profit that IBM makes. Remember to consider all sources of costs.

- 4 Let us study Engineering students at the University of Toronto. Find a model for the number of undergraduate students in the Engineering school at the University of Toronto and how they change from year to year.
- 5 You are working for Canada Revenue Agency and the queue in the IRS complaints section is getting too large and lengthy. One way to solve this would be to stop collecting taxes, but that's not possible, so you are tasked with modelling the queue.
Model a queue on a typical weekday afternoon minute by minute.
- 6 Read the example above about the gambler's ruin. Finish creating a model for it.
- 7 A ball bouncing on the floor.
- 8 A person has some fever and takes tylenol every 4 hours. What is the concentration of tylenol in her bloodstream?

49

Let us expand on the economic example above.

We put a certain amount of money in a savings bank account with an annual interest rate of $p\%$, and compounded at regular periods of α (in years).

Even though we call $p\%$ the annual interest rate, because it is compounded during the year, at the end of the year the effective annual interest rate $p_{\text{eff}}\%$ is actually higher.

Calculate the effective interest rate $p_{\text{eff}}\%$.

50 The goal of this question is to try to understand the meaning of average lifespan.

50.1 Consider a small tribe, where the people in there died at the ages:

42, 56, 46, 52, 5, 103, 47, 67, 67, 85, 57, 42, 47, 67, 46, 42, 5, 46, 57, 42.

What is the average lifespan of this tribe's population?

50.2 Consider another small tribe, where people recorded their lifespans differently. Below is a table with the percentage of the population that died at each age:

Percentage of population	2%	5%	9%	9%	16%	22%	37%
Age at death	98	82	71	66	61	53	48

What is the average lifespan of this tribe's population?

Given a population with

- μ = probability that an individual will die between two seasons.

51.1 Define the following quantity

- $P(k)$ = probability that an individual born at season 0 is alive at the beginning of season k .

Find a model for $P(k)$.

51.2 What is the probability of the individual dying during the k^{th} season?

51.3 What is the average lifespan of an individual in this population?

52

Consider a population of special rabbits. Once a pair of rabbits is born, they grow and one year later they are still immature. But two years after they are born they give birth to another pair of rabbits. Model this population of rabbits.

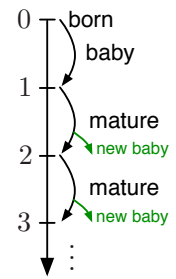

Consider another population of rabbits. This is the lifecycle of a pair of rabbits:

(year 0) Born

(year 1) Immature (no babies)

(year 2) Young Adult (1 pairs of babies)

(year 3) Adult (1 pair of babies)

(year 4) Old (no babies)

(year 5) Die

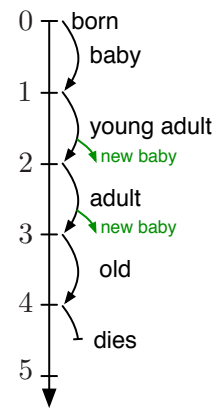

Model this population of rabbits.

Analysis of Difference Equations

In this module you will learn

- some ways to analyze models with difference equations

We have seen some different types of models involving difference equations. We have also seen a few different ways to solve them.

We will now see an example of how we can analyze a difference equation.

Example.

Consider the following model for the number of Mathematics students at a University:

- e_k = number of students in the year 2020 + k ;
 - a_k = number of students admitted to the first year;
 - g = percentage of students that graduate every year;
 - q = percentage of students that quit the Mathematics program every year.
- $$e_{k+1} = e_k + a - ge_k - qe_k$$

Finding the equilibrium point(s)

What is the equilibrium number of students E ? This means that we are looking for a solution that remains constant $e_{k+1} = e_k = E$.

$$E = E + a - (g + q)E \Leftrightarrow E = \frac{a}{g + q}$$

This is the value that the department should strive for, since it would remain stable.

Numerical approximations

For models with difference equations, we don't need numerical methods, since the recursive definition of the sequence is already a numerical method in itself.

We can follow the same approach however and run some numbers and with different values for the parameters to gain some intuition on the solutions.

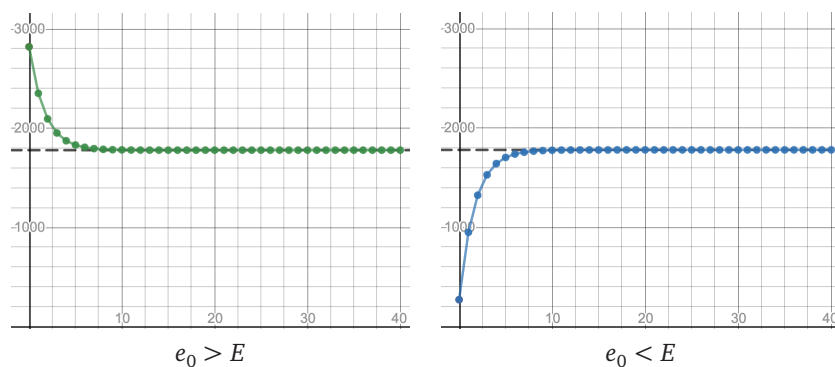

You can access this simulation here:

■ <https://www.desmos.com/calculator/wv3oxrjvrz>



Qualitative evolution of quantities

Let us now look at what happens if the situation is not in equilibrium. The numerical study above, gives some intuition about the behaviour of solutions.

Let us assume that $e_k > E$. Then

$$\begin{aligned}
 e_{k+1} &= e_k(1 - g - q) + a \\
 &> E(1 - g - q) + a && \text{(see note below)} \\
 &= E - E(g + q) + a \\
 &= E - \frac{a}{g + q}(g + q) + a \\
 &= E
 \end{aligned}$$

Note. This step is only true if E and $1 - g - q > 0$. (Why?)

It's clear that E should be positive, since it is a number of students.

The other quantity is not so obvious: $g + q < 1$?

In fact, $g + q$ is the fraction of students that graduate or quit the Mathematics program, so it can't exceed 1! (Why?)

We conclude that if $e_k > E$, then $e_{k+1} > E$. This means that if the number of students starts above the equilibrium, then it will always stay above it.

But will the number of students keep increasing without bound or will it converge to a number?

Let us check:

$$\begin{aligned}
 e_{k+1} - e_k &= a - e_k(g + q) \\
 &< a - E(g + q) \\
 &= a - \frac{a}{g + q}(g + q) \\
 &= 0
 \end{aligned}$$

So we conclude that

$$e_{k+1} - e_k < 0 \iff e_{k+1} < e_k,$$

so the number of students will decrease.

Our conclusion is that if $e_k > E$, then $e_{k+1} \in [E, e_k]$:

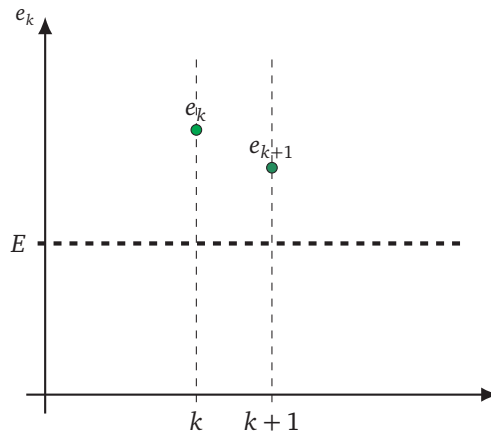

Similarly, if $e_k < E$, we can conclude that $e_{k+1} \in [e_k, E]$:

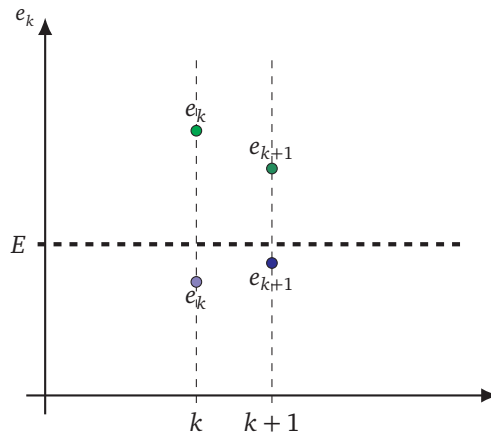

So we can see that the sequence e_k will be approaching E , so we can say that the **equilibrium is stable**.

Limiting behaviour of the solutions

From our previous analysis, we can see that it looks like

$$\lim_{k \rightarrow \infty} e_k = E.$$

But we didn't prove this yet. It could be that the sequence converges to some other value.

To show this, we would need to define a new sequence $x_k = e_k - E$, assume that it has the form $x_k = Cr^k$ and then obtain a characteristic equation for r :

$$r = 1 - g - q \in (0, 1),$$

so $x_k = Cr^k$ and

$$\lim_{k \rightarrow \infty} x_k = 0 \iff \lim_{k \rightarrow \infty} e_k = E.$$

So we now know that the number of students will converge monotonically to the equilibrium.

Practice Problems

- 1 Consider the following discrete population model:
- p_k = population at the beginning of season k
 - R = basic reproduction value for the population
 - K = carrying capacity
 - $p_{k+1} = p_k + Rp_k \left(1 - \frac{p_k}{K}\right)$

(a) Define:

- $\mu = 1 + R,$
- $x_k = \frac{R}{1+R} \frac{p_k}{K}.$

Show that $x_{k+1} = \mu x_k (1 - x_k)$.

- (b) What are the equilibrium values for x_k ?
- (c) Take $R = 1, \mu = 2$. Compare this model with the continuous logistic model.
- (d) In the continuous model, solutions cannot cross the equilibrium. Change the value of R, μ and show that in this discrete model, solutions can cross the equilibrium.
- (e) Take $R = 3, \mu = 4$ (constants for influenza virus). Below is a graph with $x_0 = 0.1$ and $x_0 = 0.101$.

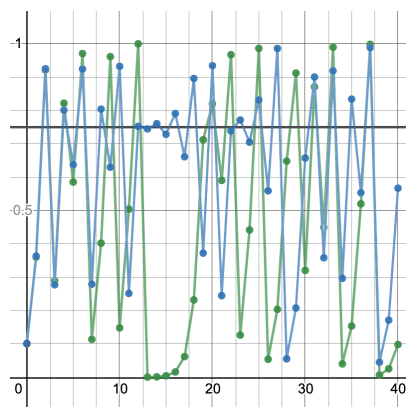

Which conclusions do you take from this graph?

- (f) Take $x_0 = \frac{1}{2}$. What happens to x_k as k gets larger and larger: does it remain bounded, or does it converge to $\pm\infty$? Check for different values of μ .
- (g) You'll need to program for this exercise. Now allow complex values for $\mu \in \mathbb{C}$. In a graph, mark the values of $\mu \in \mathbb{C}$, for which x_n does not diverge to infinity.

2 Consider the model for a queue:

- q_n = number of people waiting in the queue at minute n ;
- γ = fraction of the people waiting that are attended each minute;
- μ = average number of people that give up waiting in the queue per minute;

- (a) First, let us find out a very bad scenario for the queue. Find a number of initial people in the queue q_0 such that the size of the queue will never change.
- (b) Let

- p_k = probability that a person who joined the queue at time $k = 0$ will still be waiting after k minutes.

Is p_k increasing, decreasing, or not monotone?

- (c) The probability that someone waited exactly k minutes is $p_k - p_{k+1}$. Find another expression for $p_k - p_{k+1}$ without using p_k .
- (d) The expected waiting time in the queue is given by the "law":

The expected waiting time is the weighted average of the possible waiting times, where the weights are the probability of waiting that exact amount of time.

Find the expected waiting time for this queue.

3 Two computers are facing each other on video conferencing software. The first computer makes a sound and every fraction of a second, the other computer reproduces the sound.

Consider the following model for the microphone feedback:

- v_n = volume produced by the first computer (in dB) for the n iteration;
- e = fraction of the original volume reproduced by the second computer;
- M = maximum volume that first computer can produce (in DB).
- $v_{n+1} = e v_n \left(\frac{M - e v_n}{M} + 1 \right)$.

- (a) What is the initial volume that will just cause the following iterations to be the same?
- (b) Find a condition on e that allows for the previous situation to occur.
- (c) Assume $e \in (0, 1)$. What happens if the initial volume is softer than the equilibrium? What happens if the initial volume is louder than the equilibrium?
- (d) Assume $e > 1$. What happens if the initial volume is softer than the equilibrium? What happens if the initial volume is louder than the equilibrium?
- (e) Assume $e = \frac{8}{5}$. Sketch a graph of the solution. What is the behaviour of the solution as n gets larger?
- (f) Assume $e = \frac{1+\sqrt{5}}{2}$ the golden ratio. Is there an initial volume that gives a periodic solution: $v_0 = v_2 = v_4, v_3 = v_5 = \dots$ and $v_1 = v_3 = v_5 = v_7 = \dots$?

54 Consider the following difference equation:

$$u_{k+1} = a(u_k - b)$$

54.1 What is the equilibrium solution?

54.2 Are there 2-periodic solutions? I.e. satisfying

- $v_0 = v_2 = v_4 = v_6 = \dots$
- $v_1 = v_3 = v_5 = v_7 = \dots$
- $v_0 \neq v_1$

54.3 What happens to the solutions for different values of a ?

54.4 What happens to the solutions for different values of b ?

Consider a drunkard that is walking randomly near a cliff.

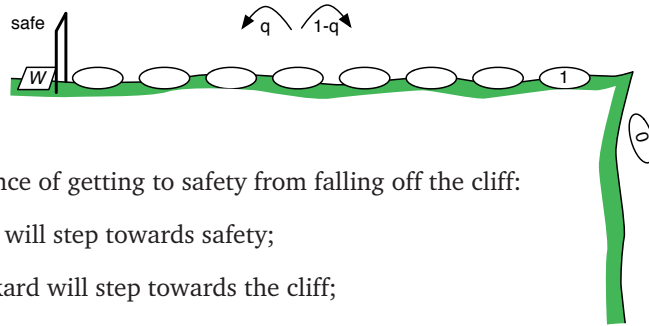

Consider this model for the drunkard's chance of getting to safety from falling off the cliff:

- q is the probability that the drunkard will step towards safety;
- $1 - q$ is the probability that the drunkard will step towards the cliff;
- $p_n =$ probability that the drunkard will get to safety if he is in step number n ;
- The drunkard will stop moving if he gets to safety (step W) or if he falls out of the cliff (step 0);
- $p_n = qp_{n+1} + (1 - q)p_{n-1}$.

55.1 Is p_n increasing or decreasing?

55.2 What is p_0 ? What is p_W ?

55.3 Let $q = \frac{1}{2}$. What is $p_{W/2}$? Is p_n symmetric around $n = \frac{W}{2}$?

55.4 Let $q > \frac{1}{2}$. Is $p_{W/2} > \frac{1}{2}$? Is $p_{W/2} < \frac{1}{2}$?

55.5 How do solutions for $q = \alpha$ and $q = 1 - \alpha$ compare?

Consider a population of rabbits with the following lifecycle:

- (year 0) Born
- (year 1) Immature (no babies)
- (year 2) Young Adult (1 pair of babies)
- (year 3) Adult (1 pair of babies)
- (year 4) Old (no babies)
- (year 5) Die

Consider the definitions:

- We start with 1 pair of newborn rabbits in year 0;
- r_n = number of pairs of rabbits alive during year n ;
- i_k = number of immature pairs;
- y_k = number of young adult pairs;
- a_k = number of adult pairs;
- o_k = number of old pairs.

- 56.1 Show that $b_k = b_{k-2} + b_{k-3}$.
- 56.2 Show that $y_{k+1} = o_k + o_{k+1}$.
- 56.3 Show that $r_n = r_{n-2} + r_{n-3}$.

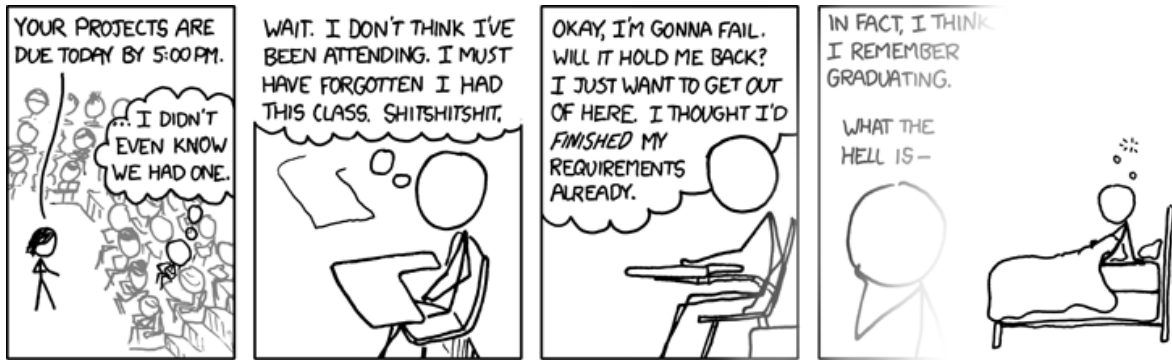

FUN FACT: DECADES FROM NOW, WITH SCHOOL A DISTANT MEMORY, YOU'LL STILL BE HAVING THIS DREAM.

(image from xkcd - comic #557)

Ecology of dragons



One of the dragons from the Games of Thrones series. (©HBO)

Scientists are sometimes asked to advise producers of fictional films: about the feasibility of a pileup, description of a sinking ship, problems to be resolved during the colonization of a planet, etc. Another example is the use of dragons in the Game of Thrones television series and in films from the books on the young wizard Harry Potter¹: how do you realistically and plausibly describe fictional animals? Sometimes science comes after the film is made. L.M. Krauss's *The Physics of Star Trek* (Harper (1995)) is one such example. This latest project invites you to advise the producers of the Game of Thrones series after the fact.

In this series from the novels “A Song of Ice and Fire”,² three dragons are bred by Daenerys Targaryen. At hatching, dragons are small, around 10kg, and after a year they weigh between 30 and 40kg. Their growth lasts a lifetime and depends on their environment and the food available to them.

Suppose that these three dragons live today and that the data in the previous paragraph is correct. You will need to make additional assumptions, such as the ability to fly long distances, spit fire, and survive major injuries. You will have to relate these hypotheses (height and weight, diet, etc.) to the questions you are studying.

Task. Your team should analyze the ecology of dragons: their behaviour, their habits, their diet and the interaction with their environment.

A non-exhaustive list of questions includes:

1. What are the dimensions, physical characteristics and longevity of an adult dragon?
2. What is the ecological impact and the needs of a dragon?
3. What is the energy expenditure of a dragon (daily, weekly?) and what are their calorie intake needs?
4. How much land is required to maintain these three dragons alive?
5. What is the size of the team (of humans) required to care for these dragons?
6. How much energy is released when a dragon spits? How long does a flame jet last? How many jets can it emit per day?
7. Can dragons migrate? And if so, how far and for how long can they migrate?

Other questions may be added depending on your modelling process. If necessary, you can comment on the impact of the climate (arid, temperate, northern regions) on the questions you have chosen. Some of the issues considered will be linked together; you should highlight these links and ensure that the models developed are not contradictory.

Finally, even if your analysis is focused on fictional animals, you are invited to describe and discuss (real) situations, other than the ecology of fictional dragons, where your modelling efforts could be useful.

One last word. The animals are fictional, but the model must be realistic and plausible!

“Ecology of dragons” is a collaboration with Yvan Saint-Aubin.

¹J.K. Rowling, *Harry Potter*, seven books published by Bloomsbury (in England) from 1997 to 2007.

²J.R.R. Martin, *A Song of Ice and Fire*, five books published by Bantam (in Canada and USA) from 1996 to 2011.

Influencers

You will no doubt have heard of the concept of a “small world”, where people measure the “degree of proximity” to a well-known person. For example, I know someone (A) who knows someone (B) who knows the Prime Minister:

- $\text{Me} \rightarrow \text{A} \rightarrow \text{B} \rightarrow \text{Prime Minister}$;
- This places me at 3 degrees from the Prime Minister.

Paul Erdős (1913-1996), was one of the most prolific mathematicians: yes, he published a lot (more than 1500 scientific articles), but he is also known to be an “**original**”: he had no fixed home, always moved from place to place to work with friends. This very special life led to the creation of the **Erdős number** which works exactly like the degree of proximity to the Prime Minister or to any known person!

In fact a whole website – <https://oakland.edu/enp> – is devoted to the work of Erdős and his collaborators. On this site, we were able to extract a **database** (<https://uoft.me/erdos> ) which contains the list of mathematicians who have an Erdős number = 1. Each line of this database contains:

- {number of collaborator (classified in alphabetical order),
- number of collaborators in this same list,
- number of collaborators who have a Erdős number = 2,
- name of the mathematician,
- number of collaborators in this list separated by a comma }

Example. {1, 7, 16, "ABBOTT, HARVEY, LESLIE", 186, 308, 318, 321, 401, 429, 450}

means that Harvey Abbott (no. 1 on this list) wrote papers with 7 others mathematicians whose Erdős number is 1, and 16 whose Erdős number is 2. His collaborators with Erdős number = 1 bear the labels: 186, 308, 318, 321, 401, 429, 450.

Task. But who is important in this list?

1. Propose some models for “being important” within this community of mathematicians with Erdős numbers = 1.
2. For each, explain its advantages and disadvantages in one complete sentence.
3. Will your model work for the following cases:

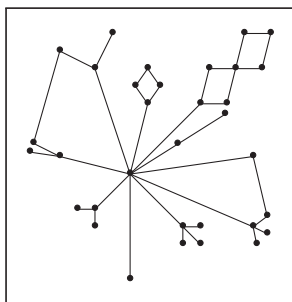

G_1

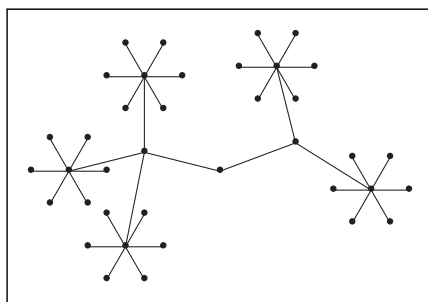

G_2

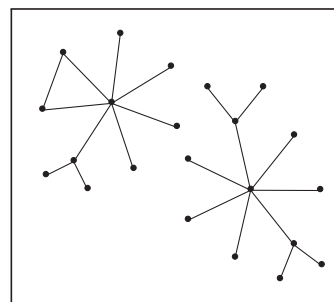

G_3

Based on “How to measure influence and impact”, ICM 2014.

“Influencers” is a collaboration with Yvan Saint-Aubin.

Elephants: too much is too much!

A large national park in South Africa is home to around 11 000 elephants. Wildlife management policies establish that a healthy environment for this herd will keep it at 11 000 heads. Each year the park officials assess the elephant population. During the past 20 years, part of the herd has had to be removed to keep the population as close to the 11 000 number as possible. “Withdrawing” part of the herd means either slaughtering the animals or moving them. Until now, 600 to 800 animals were moved each year.

Recently, environmental and animal welfare groups have protested against killing elephants. In addition, it is no longer possible to move even a small population of elephants each year. Fortunately, a contraceptive dart has been developed, which prevents a mature elephant from conceiving for a period of two years.

Here is some information about the elephants in the park:

- There is very little migration of elephants.
- The gender ratio is close to 1:1 and control measures should be chosen to maintain this ratio.
- The gender ratio of baby elephants is also 1:1. Twins are born in 1.35% of pregnancies.
- The elephant’s maturity period begins between 10 and 12 years and continues until the age of 60. They produce an average of one baby elephant every 3.5 years. Gestation lasts approximately 22 months.
- Elephants who have received a contraceptive dart are in oestrus once a month, but cannot conceive. An elephant who has not received a dart usually has only one seduction and mating period per 3.5 years; the monthly heat period can therefore cause additional stress.
- An elephant can receive a dart each year without negative effects. A mature elephant will not be able to conceive during a period of 2 years from the moment when she received the dart.
- About 70% to 80% of baby elephants reach the age of one year. Afterwards, the survival rate is uniform up to the age of 60 and very high (above 95%). Few elephants are over 70 years of age.
- There is no hunting or poaching in the park.

The park management team has **data** (<https://uoft.me/elephants> ) on the approximate age and gender of elephants relocated outside the park during the past two years. Unfortunately, no data is available on the elephants that have been slaughtered or that constitute the herd present in the park.

Task. The overall goal of the project is to investigate the feasibility of a herd control program using contraceptive darts. More specifically:

1. Develop a model and use it to describe the probable survival rate of elephants from 2 to 60 years old. Also speculate on the demographic curve of the herd present in the park.
2. Estimate how many elephants need a dart each year to keep the herd at around 11 000 heads. Show how the uncertainties in the data at your disposal can influence your estimate. Comment on possible changes in the demographic curve and how these changes could have an impact on the tourism industry over a 30 to 60 year horizon.
3. Some opponents of the contraceptive dart technique claim that, if there was a sudden disappearance of a large part of the herd (for example following an illness or poaching out of control), the ability of the population to return to its optimal level would be seriously compromised, even if the dart program was quickly discontinued. Investigate this statement and respond to this concern.

Managing a fishery

The population $P(t)$ of a species of fish in a finite environment, like a lake is often described by the logistic equation

$$\frac{dP}{dt} = rP \left(1 - \frac{P}{K} \right),$$

where r is the natural growth rate of the population and K is the maximum number of individuals that the environment can sustain.

If that population is harvested at the rate of $H(t, P)$ fish per year, then it can be modelled by the ODE

$$\frac{dP}{dt} = rP \left(1 - \frac{P}{K} \right) - H(P, t).$$

This ODE assumes that the population is harvested continuously throughout the year, which is not exactly true. Later in the course we will see how to make a better model.

Task. Your goal is to figure out the maximum profit you can generate from this population of fish. For that, it should be clear that it is undesirable to harvest too much, since it may lead to the extinction of the fish.

1. Selling fishing licenses. As the manager of the lake, you decide to profit from it by selling fishing licenses to people and allow them to fish there.

- Assuming that an average person, after a whole **day** fishing, has an efficiency³ of $E\%$, what is $H(P, t)$ and what is the ODE that models the fish in the lake?
- There is a percentage E^* , such that if $E \geq E^*$, then the population will become extinct. What is E^* ? Explain why the population will become extinct.
Hint. You don't need to solve the ODE.
- A sustainable yield Y is the rate at which the fish can be harvested indefinitely: it is the value of $H(P, t)$ which doesn't change with time and for the asymptotically stable population.
Determine the maximum⁴ value of E to maximize Y and then find the maximum Y_{\max} .

2. Selling fish. As the manager of the lake, you decide to profit from it by harvesting the fish yourself and selling it.

- Now the fish are harvested at a constant rate h . What is $H(P, t)$ and what is the ODE that models the fish in the lake?
- There is a rate h^* , such that if $h \geq h^*$, then the population will become extinct. What is h^* ? Explain why the population will become extinct.
Hint. You don't need to solve the ODE.
- If $h \leq h^*$, what is the maximum sustainable yield Y_m ?

Further Investigation.

- Can you think of other forms for $H(P, t)$?
- If, instead of a logistic model, you include an extinction threshold as well, what can you say about the model for constant effort fishing? for constant rate fishing? Is it a useful addition to the model? Have fun with it!

³Efficiency of $E\%$ means that after a whole day fishing, that person will have caught $E\%$ of the existing fish in the lake.

⁴This value can be controlled, e.g. by defining the time available for fishing in a day.

X-ray attenuation

An X-ray tube fires X-rays, which travel in a straight line. An X-ray detector will give you the intensity of any X-ray that hits the detector. If there is a vacuum between the X-ray tube and the X-ray detector, then the X-ray will have the same intensity when it hits the detector as when it left the tube. However, when X-rays pass through matter they interact with the atoms in the material and are sometimes deflected off course, or absorbed. We call this phenomenon **attenuation of the X-ray** and it results in a decrease in the intensity of the X-ray beam. When this happens, the X-ray detector will show a lower intensity than the original intensity of the X-ray.

The intensity of an X-ray is measured in keV (kiloelectronvolt).

Task.

1. Experiments indicate that the rate of decrease in the intensity of the X-ray beam as it travels through some matter is proportional to the **linear absorption coefficient** A of the material. Find an ordinary differential equation (ODE) to model the intensity, I , of an X-ray beam fired into some uniform matter with linear absorption coefficient A . Be sure to include an initial condition.
 - What are the units of A ?
 - Classify the equation.
 - Solve the equation in terms of the initial condition and A .

2. How far into a material can an X-ray beam travel before its intensity has decreased to $\frac{1}{e}$ times its original intensity.

Now you will explore one of the main ideas behind medical X-ray imaging. In order to do this, you need to know the linear attenuation coefficient of healthy human tissue.

3. You have a 15keV X-ray tube and an X-ray detector. When you fire the X-ray through 10cm of healthy tissue, you measure $\frac{15}{e}$ keV on your X-ray detector. When you fire the X-ray through 20cm of healthy tissue, you measure $\frac{15}{e^2}$ keV. Using your model of X-ray attenuation, estimate the linear attenuation coefficient of healthy tissue.

This is the basis for using X-ray Computed Tomography (CT) used in medical imaging! We can recognize healthy versus unhealthy tissue by using what we know about their attenuation coefficients. To do this in a human body requires more advanced mathematics such as the Radon transform introduced in 1917 by Johann Radon. However, consider a simple case below.

4. Suppose that you have a 10cm \times 2cm rectangle with the same linear attenuation coefficient as healthy tissue, and somewhere inside this square is a circle of unknown size having a linear attenuation coefficient different from that of healthy tissue.
 - Using an X-ray tube and an X-ray detector, can you locate the circle and determine its radius? How?
 - Can you determine the linear attenuation coefficient of the circle? How?

5. In actuality, a more complex model is needed for accurate imaging. The linear attenuation coefficient is actually dependent on the intensity of the X-ray! How does this impact your model? Discuss how this would impact your solutions to the above problems.

“X-ray attenuation” is a collaboration with Craig Sinnamon.

Predator-prey chase

Question. What is the path of a lion chasing an antelope?

Rules.

- The antelope flees at a constant speed v in a straight line
 - The lion chases at a constant speed u
-

Task.

1. Assume the antelope starts at $(0, 0)$ and moves up the y -axis. What is its position?

$$(0, vt)$$

2. Assume the lion's position is $(x(t), y(t))$. What happens if $x(0) = 0$?
3. Assume the lion's position is $(x(t), y(t))$ with $x(0) \neq 0$. For simplicity, assume that $x(0) < 0$. What is the sign of $x'(t)$?
4. The goal is to find the path, so we are looking for an equation to describe $y(x)$. Using the result from **3.**, explain why the solution will be a function $y(x)$.
5. The lion's speed is u . Express that condition using $x(t)$ and $y(t)$.
6. Find an expression for $\frac{dx}{dt}$ without the variable t .
7. Which condition on $\frac{dy}{dx}$ do we get from the fact that the lion is chasing the antelope? Draw a picture.
8. Use **7.**, and obtain an expression for $\frac{dx}{dt}$ in terms of $\frac{d^2y}{dx^2}$.
9. Obtain a Differential Equation that describes the lion's path $y(x)$.
10. For simplicity, assume that the lion starts at $(-1, 0)$. Solve this Initial-Value problem.
11. When does the lion actually catch the antelope?

Further investigation.

1. Program the pursuit (it will be approximated) and check your answer.
2. Can you figure out the path of the lion for other antelope trajectories? Program that pursuit and check your answer.
3. (for fun) Program a "game" where you control the antelope and the computer controls the lion.

Epidemic modelling

Goal. We want to model the spread of the CoViD-19 pandemic in Canada.

SIR Model. This is the typical model for an infectious disease. We start by dividing the population into three groups:

- Susceptible Individuals $S(t)$ = number of people who haven't contracted the disease;
- Infected individuals $I(t)$ = number of people infected;
- Removed individuals $R(t)$ = number of people that either died or recovered from the disease and are now immune to it.

Assumptions.

- (a) Population size N is large and constant (no birth, death, or migration);
- (b) No latent/incubation period (there is an improved model that includes this - SEIR model);
- (c) Homogeneous population;
- (d) Recovery rate is constant γ (includes rate at which people die or recover from the disease);
- (e) Out of all possible interactions between susceptible and infected individuals $S(t) \cdot I(t)$, there is a proportion $\frac{\beta}{N}$ that will result in the susceptible individual becoming infected;
- (f) The probability that an infected person will either die or recover is γ .

ODE. From here we can obtain the SIR model:

$$\begin{aligned}\frac{dS}{dt} &= -\frac{\beta}{N}SI \\ \frac{dI}{dt} &= +\frac{\beta}{N}SI - \gamma I \\ \frac{dR}{dt} &= +\gamma I\end{aligned}$$

Video.

- <https://youtu.be/f1a8JYAixXU>



Important.

- An important constant in this model is $R_0 = \frac{\beta}{\gamma}$, called the basic reproductive number, which informs us about how fast the disease propagates.
- The expected time from infection to recovery (or death) can be proved to be $T = \gamma^{-1}$.

Data. Data from the Public Health Agency of Canada:

■ <http://uoft.me/covid19-canada>



Task.

1. Explain how the system of ODEs relates to the assumptions.
2. Estimate the constants N, R_0, β, γ for Canada.
3. Using the idea from Euler's Method (used to approximate the solution of one first-order ODE), create a method to approximate the solution $S(t), I(t), R(t)$ of the SIR model.
4. Compare your approximation from 3 with the actual data.
5. Observe that the data is the result of the lockdown measures imposed in Canada. Find a value for R_0 that best matches your approximation to the data.
6. Study what happens to Canada if the lockdown measures are lifted when the number of infected people is very small vs when the number of infected people is actually zero.

Further Investigation.

1. How does the model change if some people can get reinfected? What happens if there is a vaccine available but it doesn't work for everyone? What happens when there had been lockdown and it is slowly (or brutally) lifted?

Hint. All these require new hypotheses, changing the differential equations, exploring the new solutions, etc.

2. Study what happens to the model when $R_0 < 1, R_0 = 1$ or $R_0 > 1$.
3. Adapt your method to the SEIR model and answer questions 1-6 above for the new model.
4. Improve the SEIR model to better model different lockdown scenarios.

Hunting inspiration

Snow collects on the brim of your fur coat and musket as you stalk your prey through the white woods. A flash of orange, a rustling of branches, and then it's gone. You mutter a curse under your breath. Foxes are scarce this year, and you'll have to explain to the Dutch East India Trading Company why you've come up short. Worse yet, your rival, a trapper who only hunts rabbits, is having a terrific year. You shouldn't have teased him so much when rabbits were down and foxes were up just a few seasons ago.

If only you could somehow predict which game would be plentiful, you could always bid on the easier contract! But how?

Back at camp, amid the crackling of your lonely fire, the answer comes to you. Just two months ago you attended a talk by Dr. Lotka on autocatalytic chemical reactions. It was quite a spectacle when, after Dr. Lotka had finished talking, a Dr. Volterra stood up and proclaimed that he had applied the same model to predator-prey ecology. At the time you were rushed and didn't think much about the proclamation, but now the basic assumptions were making more and more sense:

In the absence of foxes, the rabbit population grows at a rate proportional to the number of rabbits.

In the absence of rabbits, the fox population declines at a rate proportional to the number of foxes.

The population of rabbits declines at a rate proportional to the product of the rabbit and fox populations.

The population of foxes grows at a rate proportional to the product of the rabbit and fox populations.

Pop! A hot coal explodes, snapping you out of your pondering state and into one of action. Grabbing a piece of paper from your limited supplies, you begin to grapple with the consequences of the Lotka–Volterra model.

Task. Let R and F stand for the rabbit and fox populations, respectively, and let α , β , γ , and δ be the constants of proportionality for parts (a)–(d).

Work through the following before you begin your report.

1. Write down the Lotka-Volterra system of differential equations. For each of (a)–(d), explain whether or not the assumption is reasonable.
2. When is the fox population increasing or decreasing? Given R and F , could you predict which one is on the rise on which one is on the decline?
3. Is there a steady state for the fox population? Could the fox population remain steady while the rabbit population is changing?
4. Sketch an RF -phase portrait for the Lotka-Volterra system of differential equations with the following constants:

$$\alpha = 0.2 \text{ rabbits per month per rabbit}$$

$$\beta = 0.1 \text{ foxes per month per fox}$$

$$\gamma = 0.002 \text{ rabbits per month per rabbit-fox}$$

$$\delta = 0.001 \text{ foxes per month per rabbit-fox}$$

Hint: you will need to consider rabbit and fox populations of well over 100 to see interesting behaviour in your phase portrait.

5. Does your phase portrait have any singular points? What do they mean?
6. Use technology to graph $R(t)$ and $F(t)$ for some initial conditions. Do the initial conditions affect the period of the population increase or decrease? Does this seem reasonable when looking at your phase portrait?

Your writeup should include the following:

- An explanation of the Lotka-Volterra model along with a discussion of whether or not each assumption is reasonable.
- A description of what behaviour you expect from which initial conditions. You may use the parameters specified in question 4.. Include a phase portrait in your description as well as how to interpret the phase portrait, and make sure to point out any critical points.
- Suppose you wanted to legislate limits on the hunting of rabbits and foxes to ensure the population of either never dipped below a certain level. Based on the Lotka-Volterra model, propose legislation. Be specific and comment on whether a flat-out hunting ban would achieve the desired effect.

Be careful with your simulations. Euler's method loses accuracy quickly on Lotka-Volterra-based systems.

“Hunting inspiration” is a collaboration with Max Brugger.

Arms race

In this project, you will develop and analyze models for an arms race between two countries.

Define the following:

- $t \geq 0$ represent time in years;
- $x(t)$ and $y(t)$ represent the yearly military budget (in dollars) of countries Blue and Red respectively.

Task 1. Mutual Fear! For a first model, assume that each country increases its military budget at a rate directly proportional to the existing military budget of the other nation.

- What are the equations that define this model?
Hint. There should be two constants in your model.
- Solve the system and sketch a phase portrait.
- What does the model predict about the long term military budgets of the two countries?

Task 2. The Richardson Model. Now include some limiting factors in to the model you set up above. Assume that in addition to the budget increases in the mutual fear model, each country's military budget decreases at a rate proportional to its current military budget and increases at some fixed (independent of military budget) rate due to a long standing grievance.

- What are the equations that define this model?
Hint. There should be six constants in your model.
- Under what conditions (on the six constants) can the arms race stabilize? By stabilize we mean that the military budgets remain at some fixed amount, or that the budgets approach some constant amounts.
 - There is a line L_B , called the optimal line for Blue, in the phase plane such that if $(x(t), y(t))$ lies on L_B then $x'(t) = 0$. What is the equation of that line?
 - Show that Blue continuously changes its military budget to bring the solution $(x(t), y(t))$ closer to L_B .
 - Repeat the previous two parts for a line L_R , the optimal line for Red.
 - What does the intersection point of L_B and L_R represent?
 - Under what conditions on the constants will the point of intersection lie in the first quadrant ($x > 0, y > 0$)? What will be the long term behaviour of the system for various initial conditions? Explain.
 - Under what conditions on the constants will the point of intersection lie in the third quadrant ($x < 0, y < 0$)? What will be the long term behaviour of the system for various initial conditions? Explain.
- What happens in the long run for various initial conditions if one or both of the “grievance” terms is/are negative? (More of a “good will” term than a “grievance” term!)
- Can L_B and L_R be parallel? What happens in this case?
- Can $L_B = L_R$? What happens in this case?
- Produce examples that demonstrate these various cases and long term behaviours. Plot or sketch their phase portraits.

Task 3. Real World. One can argue that in the real world, a runaway arms race is impossible since there is a limit to how much a country can spend. We can add carrying capacities in to the model. Let x_M and y_M be the maximum budgets of the two countries. Then consider the model

$$\begin{aligned}x'(t) &= \left(1 - \frac{x}{x_M}\right)(-ax + by + c) \\y'(t) &= \left(1 - \frac{y}{y_M}\right)(dx - ey + f)\end{aligned}$$

Analyze this model.

Further Investigation.

1. **Another Nonlinear Model.** Suppose that the equations underlying the model have the form

$$\begin{cases}x'(t) = -ax + by^2 + c \\y'(t) = dx^2 - ey + f\end{cases}$$

where $a, b, d, e, f > 0$. How many stable points are there? There are now optimal curves instead of optimal lines. Discuss the outcomes of such an arms race for various intersections of the optimal curves.

2. **The Richardson Model with Good Will.** If instead of having terms representing increases due to a grievance, what happens if you include terms representing fixed rate decreases in the military budgets of both countries due to good will?
 - What are the equations that define this model?

Hint. There should be six constants in your model.
 - What possibilities exist for the long term behaviour of the military budgets of the two countries?
 - How do the possibilities for the long term behaviour depend on initial conditions?
 - Produce examples that demonstrate the various long term behaviours.
3. Richardson with carrying capacities.
4. Extend Richardson to three countries.
5. Increase not by absolute level but by amount over stable level.

“Arms race” is a collaboration with Craig Sinnamon.

Spring data

Statement. A motion sensor was set up to measure the motion in a spring-mass system, but something went wrong and the motion sensor measured the total distance traveled instead of simply measuring the distance from the sensor. The experiment was conducted three times (same spring and same mass) with different initial conditions. The total distance traveled is given as the data sets in the Google Sheet spreadsheet:

■ <https://goo.gl/AFMTn8>



The conditions for the three experiments were:

Data Set #1. Initial position: $y(0) = 1$. Initial velocity: $y'(0) = 0$.

Data Set #2. Initial position: $y(0) = 0.5$. Initial velocity: $y'(0) = 1$.

Data Set #3. Initial position: $y(0) = -0.75$. Initial velocity: $y'(0) = -2.5$.

Experimental Setup.

- The sensor gathered data at a rate of 20 samples per second.
- The experiment was run for 5 seconds.
- $y(t)$ is the distance from the equilibrium position of the spring-mass system. Positive values of $y(t)$ indicate that the mass was above the equilibrium position. Negative values of $y(t)$ indicate that the mass was below the equilibrium position.
- There is some noise in the data.

Task.

1. Use the data in the spreadsheet to determine the governing ODE, which should include estimates for the parameters.
2. Use the data in the spreadsheet to determine the height $y(t)$ for the different experiments.

Hint. Recall that if $y(t)$ is displacement and $v(t) = y'(t)$ is velocity then the total distance traveled is given by the function

$$d(t) = \int_0^t |v(\tau)| d\tau.$$

Further Investigation.

1. How many data sets and how many data points are needed to be able to solve the problem?
2. Add more noise to the data. Can you still solve it? How much noise can you add and still obtain good results?
3. Create your own (fake) data mimicking a spring with different properties (remember to include some noise in the data)? And solve it to show that it can be done.
4. Could you use this to detect an external force acting on the spring-mass system? Try it with two new data sets:

■ <https://goo.gl/TxzQWw>



Wing flutter

Question. Is the airplane wing going to break?

Introduction (adapted from Stuart Lee – [Click here for the original](#)).

In early 1959, with great fanfare, Lockheed's new, 4-engine prop-jet, the Electra II, went into service. The Electra looked like a "regular airline", except that the thick prop blades and the four enormous large engine covers (the nacelles and cowlings) that housed the General Electric/Allison jet-turbine driver power plants made the wings seem ever smaller and stubbier. In addition, the fuselage was relatively wide- making it one of the roomiest airliners of its time. But the Electra's appearance seemed slightly off.



The pilots soon got over the appearance and came to respect the airplane, The Electra had incredible power. One pilot remarked that "It climbs like a damned fighter plane!".

In the evening of September 29, 1959, Braniff's spanking new Electra disintegrated in midair (description).

What had caused this brand-new jet prop to disintegrate over Buffalo, Texas?

The investigators combing the wreckage of the Braniff Electra noticed something alarming. The shards of what appeared to be the left wing were found a considerable distance from the rest of the wreckage.

And the story got worse. On March 17, 1960, Northwest Airlines flight 710 left Minneapolis-St. Paul (description). Witnesses on the ground heard tearing sounds in the sky. They looked up and saw the thick fuselage of the Electra emerging from the clouds. The entire right wing was missing, and only a stub of the left wing remained attached to the Electra.

The airliner seemed to float for a while, but then it dipped, diving straight down toward the ground, trailing white smoke and pieces of aircraft. The 63 people entombed in the fuselage struck the muddy ground, vertically, at 618 miles per hour. Rescuers found nothing at the site of impact larger than a spoon.

But 3 km away, they found the wreckage of the left wing.

This was beyond, alarming. In a period of less than six months, two brand-new Electras lost their wings and disintegrated with much loss of life. What could have caused this? Could it have been severe clear-air turbulence (CAT), or was there something drastically wrong with these airliners.

The airlines who had Electra fleets were nearly panicking. Meetings were quickly set up with the FAA. Investigations were set up. Boeing lent staff, simulators, and a wind tunnel to Lockheed. Douglas contributed engineers and equipment; most notably flutter vanes that, when attached to the ends of the wings, could induce serious oscillation.

The investigation, occurring in the early sixties, was the first serious use of computer stress analysis in this field.

Electras were test flown in every possible form of turbulence. Test pilots tried to destroy the Electra by ramming it into the severe Sierra Madre air waves, over and over again. Electras were put through every possible flight maneuver that would normally cause a wing failure. Super severe wind tunnel winds were shot out at Electras and mock-ups. Over and over, every possible test was done to try and break the Electra.

Finally, on May 5, 1960, an engineer stood up at a Lockheed meeting and announced: “We’re pretty sure we’ve found it!”.

Basically, the problem was a high-speed aircraft in a conventional design. Every aircraft wing is flexible to some degree. And wing vibration, oscillation, or flutter is inherent in the design. Flutter is expected on wings. In engineering terms, there are more than 100 different types of flutter – or “modes” – in which metal can vibrate. The “mode” that destroyed the Electras was “whirl mode”.

Whirl mode was nothing new. It was not a mysterious phenomenon. As a matter of fact, it is a form of vibrating motion inherent in any piece of rotating machinery such as oil drills, table fans, and automobile drive shafts.

The theory was devastatingly simple. A propeller has gyroscopic tendencies. In other words, it will stay in a smooth plane of rotation unless it is displaced by some strong external force, just as a spinning top can be made to wobble if a finger is placed firmly against it. The moment such a force is applied to a propeller, it reacts in the opposite direction.

Now suppose the force drives the propeller upward. The stiffness that is part of its structure promptly resists the force and pitches the prop downward. Each succeeding upward force is met by a protesting downward motion. The battle of vibration progresses. The propeller continues to rotate in one direction, but the rapidly developing whirl mode is vibrating in the opposite direction. The result, if the mode is not checked, is a wildly wobbling gyroscope that eventually begins to transmit its violent motion to a natural outlet: the wing.

Whirl mode did occasionally develop in propeller-driven airliners. It always encountered the powerful stiffness of the entire engine package, the nacelles and the engine mounting, the mounting being a bar truss holding the engine to the wing. No problem usually. But on painful microscopic examination of the crash wreckage of the eight Electra engines, it was found that something caused the engines to loosen and wobble, causing severe whirl mode, which tore off the Electra’s wings. Specifically, the investigation centred on the outboard engines.

What the investigators found was that the engine mounts weren’t strong enough to dampen the whirl mode that originated in the outboard engine nacelles. The oscillation transmitted to the wings caused severe up-and-down vibration, which grew until the wings tore right off.

Project. In this project we will study mechanical resonance of an airplane wing due to a vibrating propeller. We use Differential Equations to create a simple model of the wing flutter.

Start with a picture of a propeller mounted on a wing.

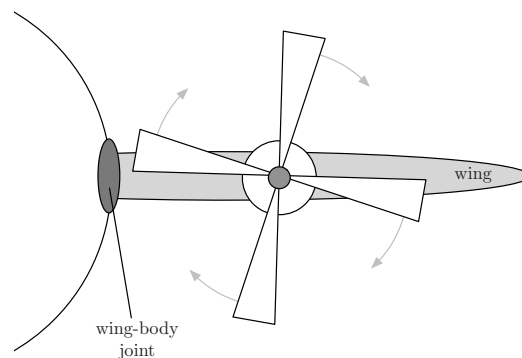

We want to keep the model simple, so we consider only the wing’s centre of mass. This implies that the wing behaves as a **spring-mass system**: the spring is the wing-body joint that allows the centre of mass to move up and down.⁵ The forcing function is the vibrational force that results from the motion of the propeller.

⁵The centre of mass actually moves on an arch, but we consider only its vertical motion.

For this example assume that the wing has a mass of 900 kg and the wing-body joint acts as a spring with constant 8100 N/m. Also assume that the damping forces are negligible and the wing is at rest when the propeller begins to vibrate.

Task.

- Let $y(t)$ be the position of the centre of mass of the wing and $f(t)$ the vertical vibrational force from the propeller. Write an IVP (Initial-Value Problem) that models the movement of the wing.
- Assuming that the propeller vibrates with a force $f_1(t) = 1800 \sin(6t)$ (in N). Find the position of the wing's centre of mass and plot it.
Describe the position of the wing's centre of mass as t grows large ($0 \leq t \leq 25$).
- Just before wing-failure, the propeller actually slowed down. Let us simulate this by changing the forcing function to $f_2(t) = 1800 \sin(3t)$ (in N).
 - Find the equation of motion using the new forcing function.
 - Plot the solution.
 - Describe the position of the wing's centre of mass as t grows large. What consequences does this have for the wing?
- It is very unlikely that the frequency of the propeller will match exactly this, so assume that $f_3(t) = 1800 \sin(3.5t)$ (in N).
 - Find the equation of motion using the new forcing function.
 - Plot the solution.
 - Using a trigonometric identity, re-write your solution as a product of two trig functions. Describe how this new form for the solution explains the plot.
 - Describe the position of the wing's centre of mass as t grows large. What consequences does this have for the wing?

Further Investigation.

- If you were the Lead Engineer in charge of fixing this problem, what would you do? How would that change the Differential Equation? Using the new differential equation, show that it would indeed solve the problem.
- What happens if there are two propellers (like the actual Lockheed Electra)?
- Can you model wing flex?

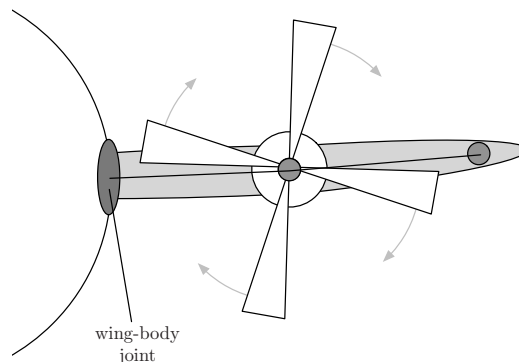

Bullwhip effect

Goal. Understand that Supply Chain Management is hard(!) and attempt to model it.

Video.

Watch the short video:

- <https://youtu.be/2nlmkTYZG5s>



to understand a bit better about the bullwhip effect.

Read.

- <http://forio.com/about/blog/bullwhips-and-beer/>



Near Beer Game (Novice). You own a (tiny) Beer Store.

You start with a stable situation where your customers have been asking for 10 cases of beer every week, and your inventory and orders match the situation (so you don't run low on inventory and you don't accumulate either).

From the second week, your customers start ordering 15 cases of beer instead.

It is your job to stabilize the whole supply chain as soon as possible.

Below is a screen from the "game".

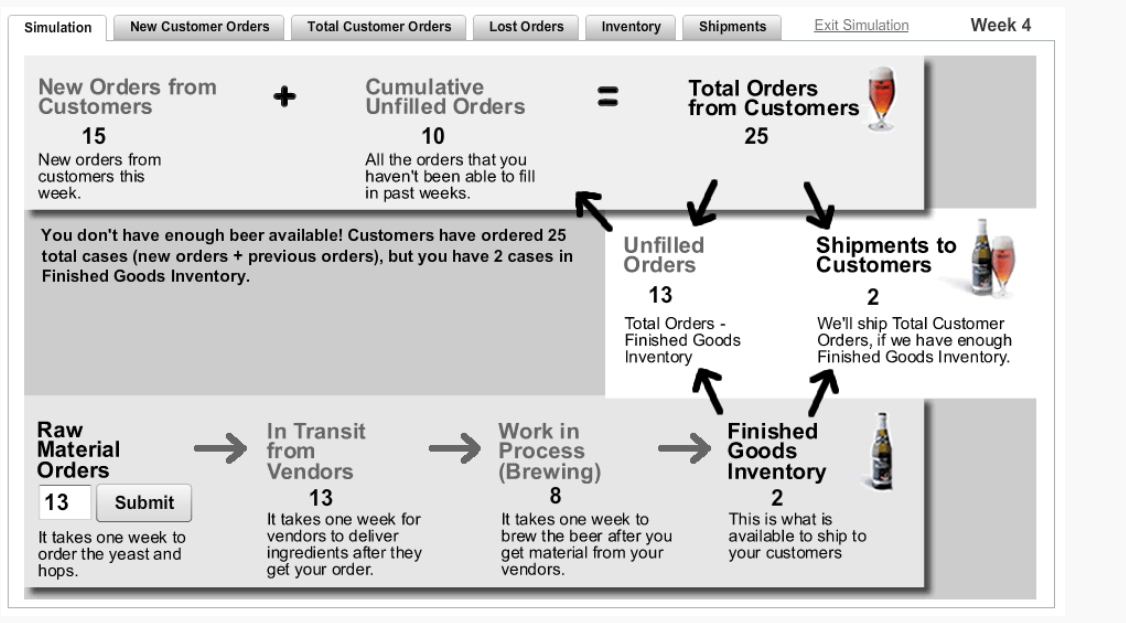

- New Orders from Customers: Number of beer cases your new customers want this week
- Cumulative Unfilled Orders: Number of beer cases that your

Go to

- <https://forio.com/simulate/mbean/near-beer-game/run/>



The goal of the “game” is to try and stabilize the number of customer orders, your inventory, arriving orders, and your order, so that you end up with the following situation

- Customer Orders: 15 cases every week (with no unfilled orders)
- Inventory: 15 cases
- Arriving Order: 15 cases
- Order 15 cases

Task 1. Play the “game” on **Novice** as a group and see how many weeks it takes to stabilize the situation.

Consider the following sequences:

- c_n = number of beer cases ordered by customers
- u_n = number of cases ordered previously but not fulfilled yet
- i_n = number of cases in inventory
- o_n = number of cases ordered
- r_n = number of cases of beer produced

where n is the number of weeks elapsed since the beginning of the “game”.

- (a) What are the initial conditions ($n = 0$) ?
- (b) What is the formula for c_n ?
- (c) What is the formula for r_n ?
- (d) What is i_n ?
- (e) What is u_n ?
- (f) Confirm that your modelling is correct, that is, that your variables follow the outcome of the game.
- (g) Decide on a strategy for ordering beer cases. Decide on a formula for o_n that can depend on n , c_n , u_n , i_n , r_n . Explain your choice.
- (h) What is the result of your strategy? Does it go “amuck” – bullwhip effect⁶? Or does it control the supply chain nicely?

⁶It’s ok if it goes “amuck”! The goal is to see the Bullwhip Effect in action... Now try to fix it!

Task 2. Play the “game” on **Expert** as a group and see how many weeks it takes to stabilize the situation. Consider the same sequences as for **1**.

The difference between Novice and Expert is that the customer orders go from $10 \rightarrow 50$ and every week 25% of unfilled orders are cancelled.

- What are the initial conditions ($n = 0$) ?
- What is the formula for c_n ?
- What is the formula for r_n ?
- What is i_n ?
- What is u_n ?
- Confirm that your modelling is correct, that is, that your variables follow the outcome of the game.
- Decide on a strategy for ordering beer cases. Decide on a formula for o_n that can depend on n, c_n, u_n, i_n, r_n . Explain your choice.
- What is the result of your strategy? Does it go “amuck” – bullwhip effect? Or does it control the ordering nicely?

Further Investigation.

- There is a more complex version of the game

■ <https://beergame.pipechain.com/>



which includes 1–4 players from 4 different stages of the supply chain. It takes 2 weeks for orders to arrive to a different stage and it takes 2 weeks to fulfill a request.

- Play the game with 2 players⁷ who do not communicate with each other, i.e., two-stage supply chain.
 - Define the new sequences
 - c_n = number of beer cases ordered by customers
 - o_n = number of cases ordered by the retailer
 - s_n = number of cases in the retailer’s stock
 - p_n = number of cases ordered by the producer
 - q_n = number of cases in the producer’s stock
 - Make a similar study for this case. Observe that now you have to decide on the strategy for both o_n and p_n .
- In the article suggested at the beginning

■ <http://forio.com/about/blog/bullwhips-and-beer/>



the author describes ways a few ways to reduce the Bullwhip effect. Program each of them with your sequence o_n and study how well they reduce the effect.

- You can avoid the Bullwhip effect completely with perfect information about the supply chain and the future customer demand. In reality, we can predict the customer demand, but it won’t match exactly the prediction. Add a little noise to customer demand and try to avoid the Bullwhip effect. You can still use the fact that customer demand will still be close to 15 cases every week.

⁷Create a game and then use another computer to join the same game

Approximating the temperature of a thin sheet

Task. We want to approximate solutions of a PDE.

The heat equation is

$$\frac{\partial^2 u}{\partial x^2} + \frac{\partial^2 u}{\partial y^2} = 0,$$

where $u(x, y)$ is the equilibrium temperature at the position (x, y) given some boundary conditions.

This is a Partial Differential Equation (PDE), which we don't know how to solve. We can however obtain an approximation of the solution.

In this example, the domain is shown on the right $\Omega = [0, 2] \times [0, 2]$ and the initial conditions are the following

$$u(x, 0) = 90 \quad , \quad u(x, 2) = 30 \quad , \quad u(0, y) = 0 \quad , \quad u(2, y) = 60.$$

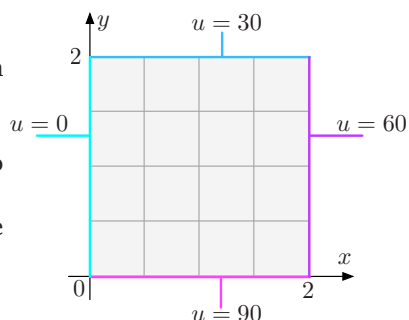

To approximate the solution, we divide the domain in N small pieces. In the example $N = 4$ and $\Delta = \frac{2-0}{N} = \frac{1}{2}$.

Then we define the points

$$\vec{p}_1, \vec{p}_2, \vec{p}_3, \dots, \vec{p}_M,$$

as the points in the interior of the domain (usually by moving left→right and bottom→top).

1. What are the points \vec{p}_n ? What is M ?

Then we define

$$u_n = u(\vec{p}_n),$$

where $u(x, y)$ is the solution of the initial-value problem above (PDE with boundary conditions).

The next step is to approximate the PDE itself. We do that by approximating the derivatives:

$$\frac{\partial u}{\partial x}(x_0, y_0) \approx \frac{u(x_0 + \Delta, y_0) - u(x_0, y_0)}{\Delta}.$$

2. What is the approximation for $\frac{\partial u}{\partial x}(\vec{p}_5)$? What is the approximation for $\frac{\partial u}{\partial x}(\vec{p}_3)$?
3. What is an approximation for $\frac{\partial u}{\partial y}(x_0, y_0)$? What is the approximation for $\frac{\partial u}{\partial y}(\vec{p}_8)$?

From here, we define the second derivative in a similar fashion:

$$\begin{aligned} \frac{\partial^2 u}{\partial x^2}(x_0, y_0) &\approx \frac{\frac{u(x_0 + \Delta, y_0) - u(x_0, y_0)}{\Delta} - \frac{u(x_0, y_0) - u(x_0 - \Delta, y_0)}{\Delta}}{\Delta} \\ &= \frac{u(x_0 + \Delta, y_0) - 2u(x_0, y_0) + u(x_0 - \Delta, y_0)}{\Delta^2}. \end{aligned}$$

4. What is the approximation for $\frac{\partial^2 u}{\partial x^2}(\vec{p}_5)$? What is the approximation for $\frac{\partial^2 u}{\partial x^2}(\vec{p}_3)$?
5. What is an approximation for $\frac{\partial^2 u}{\partial y^2}(x_0, y_0)$? What is the approximation for $\frac{\partial^2 u}{\partial y^2}(\vec{p}_8)$?

We are now ready to put it all together.

The PDE applies to all points in the domain. Instead of applying the PDE to all points $(x, y) \in \Omega$, we apply the approximation of the (second) derivatives to all the points \vec{p}_n .

6. What is the equation that we obtain for the point \vec{p}_5 ?
7. What is the equation for each point \vec{p}_n ?

These equations form a linear system of equations. Define a vector $\vec{u} = \begin{bmatrix} u_1 \\ u_2 \\ \vdots \\ u_M \end{bmatrix}$

8. Write the system of equations in matrix form $A\vec{u} = \vec{b}$.
9. Solve it and plot the solution. (You should use some software to solve this!)

MATLAB. Here is a quick introduction to some tools in MATLAB that are useful for this problem.

■ Define a matrix $A = \begin{bmatrix} 1 & 2 \\ 3 & 4 \end{bmatrix}$ by

» `A=[1,2;3,4]`

■ Define a vector $\vec{b} = \begin{bmatrix} 5 \\ 6 \end{bmatrix}$ by

» `b=[5;6]`

■ Solve the system $A\vec{u} = \vec{b}$ by defining $\vec{u} = A^{-1}\vec{b}$

» `u=A\b` or » `u=inv(A)*b`

■ To plot a 3D plot like this, define a matrix for the solutions and write

» `surf(p)`

To use the typical colouring for the heat equation, type

» `colormap(cool)`

Further Investigation.

1. Approximate the solution for the domain and boundary conditions

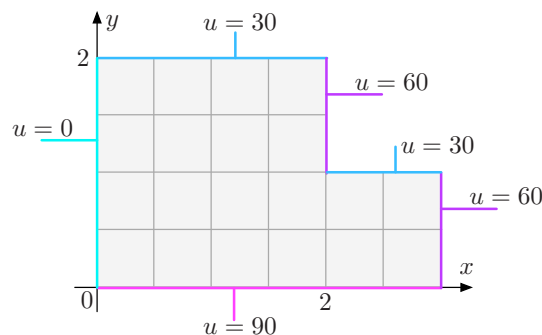

2. Formulate the procedure for a general N .
3. Formulate the procedure for a different Δx and Δy .
4. This method can be adapted to what kind of domains? And what kind of boundary conditions?

Math of lungs

Lungs are somewhat important to human beings! They are the source of oxygen to our bodies, so it is important to maximize the amount of oxygen that can be absorbed within the available volume.

Task 1. Let us find out the volume and surface area of the lungs.

- (a) The lungs are composed of a branched structure as in the figure below.

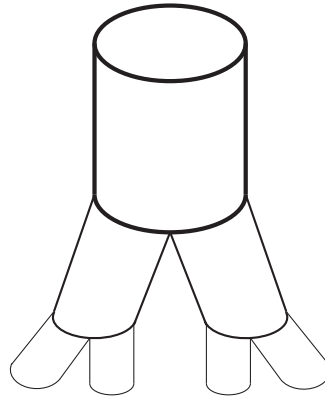

The first segment is very large, then it bifurcates into smaller segments in a geometrical pattern.

Here is some data about human lungs:

- radius of first segment: $r_0 = 0.5\text{cm}$
- length of first segment: $\ell_0 = 5.6\text{cm}$
- ratio of daughter to parent length: $\alpha = 0.9$
- ratio of daughter to parent radius: $\beta = 0.86$
- number of branch generations: $M = 30$
- average number of daughters per parent: $b = 1.7$

In the figure, there are 2 daughters per parent, in real lungs, it isn't perfectly regular, so we have an average that is not a whole number.

- (b) Calculate the volume inside the segments. What is the limit as the number of segments gets larger and larger?
- (c) Calculate the surface area inside the segments. What is the limit as the number of segments gets larger and larger?
- (d) If we had $b = 2$ instead and the same number of generations, would that be possible? If not, how many generations would be possible?

Task 2. Let us model the gas exchange that happens inside the lungs.

- (a) Suppose that a lung has a volume of 3L when full. With each breath, 0.6L of the air is exhaled and replaced by 0.6L of outside air.

After exhaling the volume is 2.4L and it returns to 3L after inhaling.

Suppose further that the lung contains a chemical with a concentration of 2 milimoles per litre before exhaling (a mole is a chemical unit for 6.02×10^{23} molecules). The ambient air has a concentration of 5mmol/L of the same chemical.

What is the concentration after one breath? What is the concentration after n breaths?

- (b) Update your model to match the oxygen exchange inside a real human lung.
- (c) The model above ignored the fact that the body absorbs some of the oxygen. Assume now that the lungs absorb 30% of the oxygen with each breath. Update your model.
- (d) What is the equilibrium concentration of oxygen in the lungs? Find the graph of the equilibrium concentration as a function of the fraction of oxygen absorbed with each breath.

You may choose to model the gas exchange in the lungs using either a discrete time *difference equation* or a continuous time *differential equation*.

- (a) If you choose a difference equation, you might assume that every breath the concentration of the chemical changes. If $c(n)$ or c_n represented the concentration of chemical after n breaths, your difference equation might look like

■ $\Delta c(n) = c(n) - c(n-1) = \text{some function at time } n$, where n is only allowed to take whole numbers.

- (b) If you choose to use differential equations, the analogous equation would look like

■ $c'(t) = \text{some function at } t$, where t can take any positive real value.

Based on a problem from

Calculus for the Life Sciences, F.R. Adler, M. Lovric, Nelson, 2015

<https://shar.es/aHFfxU>



Task 3. Assume that the lungs only absorb a fraction of the air in contact with its surface. Combine the two previous tasks.

Further Investigation:

1. Investigate how the what is known about human lungs. Compare how the branching of real human lungs differs from this model. Refine the estimate.
2. Investigate how the what is known about human lungs. Compare how the gas exchange of real human lungs differs from this model. Refine the model.

“Math of lungs” is a collaboration with Kseniya Garaschuk and Miroslav Lovric.

Dark day

At one in the morning, your phone goes off. After three attempts to turn off your alarm clock, you finally realize that it is a call – a call from a number you had promised to always answer. By 1:15, you’re dressed and out the door where a black SUV is idling, waiting for you. After a transfer to a government plane, you touch down in Washington, D.C., and as the sun finally begins to rise, you traverse down the Secret Service tunnels to a large conference room lined with leather chairs.

“I’m not going to mince words,” a voice says, from the other side of the room. The chair at the end of the table swivels round and you see the President emerge from the shadows. “It’s bad. It’s worse than bad. It’s, uh... it’s zombies.”

A revelation like that would have thrown a lesser scientist, but you’re a professional. You’ve been preparing for this for years, urging your colleagues to take the threat seriously.

“Where is the origin? Have we identified a patient zero in the US or are there multiple sources? What are the parameters of the disease?” you ask.

“Straight to work, okay,” the President says, looking pleased. “Chicago police began reporting violent attacks a few days ago. It started with a single report in the navy shipyard. The shipyard has been quarantined, but we’re now getting reports from all over the city. These attacks are carried out by humans who always attempt to bite their victims. Those bitten begin to show symptoms within a matter of hours, but those who are attacked but escape without being bitten appear normal. I’ve sent in the Marines, and they estimate that an infected person dies after eight days. They also predict about 3,000 individuals have been exposed, five days after the initial report.”

“Has any quarantine been successful?” you ask.

“No.” The President pauses and the gravity of what he has just said starts to sink in. “There are approximately 9.7 million people living in the Chicago metro area. Obviously time is of the essence. Now, I’ve been told that you’re the best epidemiologist we have. I need to know if the region has a chance of survival, and if it does, what the impact will be. Is there any hope for Chicago?”

You may choose to model the zombie outbreak using either a discrete time *difference equation* or a continuous time *differential equation*.

(a) If you choose a difference equation, you might assume that every day or every hour, the number of zombies, humans, and dead increment. If $Z(n)$ represented the number of zombies at time n , one of your difference equations might look like

■ $\Delta Z(n) = Z(n) - Z(n-1) =$ some function of zombies, humans, and dead at time n , where n is only allowed to take whole numbers.

(b) If you choose to use differential equations, the analogous equation would look like

■ $Z'(t) =$ some function of zombies, humans, and dead at time t , where t can take any positive real value.

(c) Modelling with a difference equation or a differential equation should give you similar results (why?).

Task. Model the zombie infection. Make sure to address the following in your report:

- What situation are you trying to model?
- What equations are you using, and what does each variable in each equation represent (for example, “In this model, $Z(t)$ is the number of zombies at t hours from initial outbreak”).
- Justification for any constants that you use and how you estimated them.
- Is there any hope for Chicago?

Do not attempt to find an equation that solves your differential equations—this is really hard. Instead, rely on estimates and simulations. You can use any computer program you like to assist you in estimating how the zombie outbreak spreads and whether your constants match with the known information. Including plots and figures in your report will make explaining things easier.

“Dark day” is a collaboration with Max Brugger.

Maximus vs Commodus



Maximus, the Roman general turned slave turned gladiator is seeking **vengeance!** (In this life or the next). He has managed to make his way to the Roman Forum, and now all that stands between him and nefarious Emperor Commodus is the **Prætorian Guard**.

Maximus must make his way across the Forum, defeating all Prætorians in his way, if he is to achieve his goal in this lifetime.

Conditions.

- The forum can be represented by the horizontal x -axis, in the interval $[1, 1823]$;
- Maximus starts at the left side of the forum;
- Maximus moves at a constant rate across the forum - we call this M_s (Maximus' speed);
- The arrival of Prætorian guards follows a Poisson process with rate P_r (Prætorian arrival rate);
- Prætorians appear at the right side of the forum, and move at a constant rate toward Maximus. This rate is called P_s (Prætorian speed);
- Both Maximus and the Prætorian(s) will move toward each other until blocked (by Maximus in the case of the front Prætorian, or by another Prætorian if there's a lineup waiting to turn Maximus into pulp);
- The maximum number of Prætorians is limited by the size of the forum.

When Maximus meets a Prætorian. Fisticuffs ensue!

- Maximus and the Prætorians both start with a fixed health value, let's call this H (initial health).
- Maximus strikes on the Prætorians are another Poisson process, with rate M_{hr} (Maximus hit-rate) Prætorians strike Maximus also according to a Poisson process, with rate P_{hr} (Prætorian hit-rate)
- When Maximus hits a Prætorian, he causes damage in the amount $d = M_{hv} \cdot \frac{M_h}{H}$.
That is, the damage is given by a parameter M_{hv} (Maximus hit-value) multiplied by M_h (Maximus' current health) divided by the initial (maximum) health. It's a tough world and Maximus' strikes get weaker the weaker he gets!
- The same is true for the Prætorians (with their own hit-value and corresponding health), but there's an additional factor here - it's Maximus we're talking about! He's trained in the arena and defeated the most skilled gladiators! Therefore, he is able to dodge many of the Prætorians' strikes!
Prætorians land a blow on Maximus only with probability $1/M_{tf}$ where M_{tf} is Maximus' training factor. The better trained Maximus is, the harder it is for the Prætorians to actually strike him.
- If at any point the health of the Prætorian goes below zero, the soldier dies and Maximus can continue his progress along the Forum (at least until he meets the next Prætorian).

If at any point Maximus' health goes below zero, it's over and he'll have to get his Vengeance on the next life. Happily for Maximus, as long as he's just walking (not fighting), his health regenerates at a rate given by M_{rr} (Maximus' health recovery rate). How much he'll recover depends on how far he can get before meeting his next foe!

To help you visualize the task, here is some code you can run on Octave or Matlab.

■ <https://uoft.me/maximus>



Task.

1. Using the code supplied above, find some values for which sometimes Maximus achieves vengeance in this life, and sometimes only in the next.
Hint. To speed the simulation, you might want to disable the graphics.
2. Model the fight with deterministic processes instead of the Poisson processes.
3. Fix all values and find the **critical** training value for Maximus with the deterministic processes.
4. Model the actual fight.

Will Maximus make his way across the Forum and get his vengeance on Emperor Commodus? And more importantly...

ARE YOU NOT ENTERTAINED?????!!!!!!

“Maximus vs Commodus” is a collaboration with Francisco Estrada.



IT'S WEIRD HOW PROUD PEOPLE ARE OF NOT LEARNING MATH WHEN THE SAME ARGUMENTS APPLY TO LEARNING TO PLAY MUSIC, COOK, OR SPEAK A FOREIGN LANGUAGE.

(image from xkcd - comic #1050)

7.1 Linear Algebra Review

Algebra of Solving Systems of 2 Linear Equations

We can write a linear system of equations

$$a_{11}x_1 + a_{12}x_2 = b_1$$

$$a_{21}x_1 + a_{22}x_2 = b_2$$

into matrix form

$$\mathbf{A}\vec{x} = \vec{b},$$

where

$$\mathbf{A} = \begin{pmatrix} a_{11} & a_{12} \\ a_{21} & a_{22} \end{pmatrix}, \quad \vec{x} = \begin{pmatrix} x_1 \\ x_2 \end{pmatrix} \quad \text{and} \quad \vec{b} = \begin{pmatrix} b_1 \\ b_2 \end{pmatrix}.$$

We can solve a system like this one in several different ways.

Example. Solve the system

$$3x_1 + 2x_2 = 7$$

$$2x_1 + 3x_2 = 8.$$

Solution by substitution.. We can write

$$x_2 = \frac{7 - 3x_1}{2},$$

and use this on the second equation

$$2x_1 + 3\frac{7 - 3x_1}{2} = 8 \quad \Leftrightarrow \quad 4x_1 + 21 - 9x_1 = 16 \quad \Leftrightarrow \quad -5x_1 = -5 \quad \Leftrightarrow \quad x_1 = 1$$

Then re-use the first equation we obtained to get $x_2 = 2$.

Solution by Cramer's rule.

Using the same method of substitution on the general system, we obtain

$$a_{12}x_2 = b_1 - a_{11}x_1,$$

and we use this into the second equation (after multiplying by a_{12})

$$a_{12}a_{21}x_1 = a_{22}b_1 - a_{11}a_{22}x_1 = a_{12}b_2$$

This implies

$$x_1 = \frac{b_1a_{22} - a_{12}b_2}{a_{11}a_{22} - a_{12}a_{21}} = \frac{\begin{vmatrix} b_1 & a_{12} \\ b_2 & a_{22} \end{vmatrix}}{\begin{vmatrix} a_{11} & a_{12} \\ a_{21} & a_{22} \end{vmatrix}}$$

Then we use this to obtain

$$x_2 = \frac{a_{11}b_2 - b_1a_{21}}{a_{11}a_{22} - a_{12}a_{21}} = \frac{\begin{vmatrix} a_{11} & b_1 \\ a_{21} & b_2 \end{vmatrix}}{\begin{vmatrix} a_{11} & a_{12} \\ a_{21} & a_{22} \end{vmatrix}}$$

Important. This implies that there is a unique solution of the system if and only if

$$\det(\mathbf{A}) = a_{11}a_{22} - a_{12}a_{21} \neq 0.$$

Solution by inverse matrix. A matrix is **invertible** or **nonsingular** iff \mathbf{A}^{-1} exists iff $\det(\mathbf{A}) \neq 0$.

If the matrix \mathbf{A} is invertible, then we can write

$$\mathbf{A}^{-1} = \frac{1}{\det(\mathbf{A})} \begin{pmatrix} a_{22} & -a_{12} \\ -a_{21} & a_{11} \end{pmatrix}$$

We can now use this to solve the system of equations:

$$\begin{aligned} \mathbf{A}\vec{x} &= \vec{b} \\ \mathbf{A}^{-1}\mathbf{A}\vec{x} &= \mathbf{A}^{-1}\vec{b} \\ \mathbf{I}\vec{x} &= \mathbf{A}^{-1}\vec{b} \\ \vec{x} &= \mathbf{A}^{-1}\vec{b} \end{aligned}$$

Homogeneous Systems.

A system of equations is called **homogeneous** if $\vec{x} = \vec{0}$ is a solution, which means that $\vec{b} = \vec{0}$:

$$\mathbf{A}\vec{x} = \vec{0}.$$

Otherwise, it is called **nonhomogeneous**.

Eigenvalues and Eigenvectors

We can think of the matrix multiplication $\vec{y} = \mathbf{A}\vec{x}$ as a mapping or transformation: given a vector \vec{x} it transforms it into a different vector \vec{y} .

In many applications, it is important to know which vectors \vec{x} are transformed into multiples of themselves.

These vectors satisfy the property

$$\mathbf{A}\vec{x} = \lambda\vec{x} \quad \Leftrightarrow \quad (\mathbf{A} - \lambda\mathbf{I})\vec{x} = \vec{0}.$$

One such vector is $\vec{x} = \vec{0}$. But that's not very interesting. We want to look for nonzero vectors that satisfy this property.

These vectors are called **eigenvectors** and the corresponding λ is called an **eigenvalue**.

Important. The second formulation above implies that the matrix $(\mathbf{A} - \lambda\mathbf{I})$ is singular, otherwise the unique solution would be $\vec{x} = \vec{0}$. So that implies that

$$\det(\mathbf{A} - \lambda\mathbf{I}) = 0 \quad \text{(characteristic equation)}$$

Example. Let us find the eigenvalues and eigenvectors for

$$\mathbf{A} = \begin{pmatrix} 1 & 8 \\ 4 & 5 \end{pmatrix}.$$

First we solve the characteristic equation:

$$\det(\mathbf{A} - \lambda\mathbf{I}) = \begin{vmatrix} 1-\lambda & 8 \\ 4 & 5-\lambda \end{vmatrix} = (1-\lambda)(5-\lambda) - 32 = 0 \quad \Leftrightarrow \quad \lambda^2 - 6\lambda - 27 = 0$$

which implies that

$$\lambda = 3 \pm \sqrt{9 + 27} = 3 \pm 6$$

Eigenvalue $\lambda_1 = -3$. To find the eigenvector, we write its equation

$$(\mathbf{A} - \lambda_1\mathbf{I})\vec{x} = \vec{0} \quad \Leftrightarrow \quad \begin{pmatrix} 4 & 8 \\ 4 & 8 \end{pmatrix} \begin{pmatrix} x_1 \\ x_2 \end{pmatrix} = \begin{pmatrix} 0 \\ 0 \end{pmatrix}$$

which implies that

$$4x_1 + 8x_2 = 0 \quad \Leftrightarrow \quad x_1 = -2x_2.$$

So one eigenvector for this eigenvalue is

$$\vec{x}_1 = \begin{pmatrix} -2 \\ 1 \end{pmatrix}$$

Eigenvalue $\lambda_2 = 9$. To find the eigenvector, we write its equation

$$\begin{pmatrix} -8 & 8 \\ 4 & -4 \end{pmatrix} \begin{pmatrix} x_1 \\ x_2 \end{pmatrix} = \begin{pmatrix} 0 \\ 0 \end{pmatrix}$$

which implies that

$$-8x_1 + 8x_2 = 0 \quad \Leftrightarrow \quad x_1 = x_2.$$

So one eigenvector for this eigenvalue is

$$\vec{x}_2 = \begin{pmatrix} 1 \\ 1 \end{pmatrix}$$

Theorem. Let \mathbf{A} have real or complex eigenvalues λ_1 and λ_2 such that $\lambda_1 \neq \lambda_2$ and let the corresponding eigenvectors be

$$\vec{x}_1 = \begin{pmatrix} x_{11} \\ x_{21} \end{pmatrix} \quad \text{and} \quad \vec{x}_2 = \begin{pmatrix} x_{12} \\ x_{22} \end{pmatrix}.$$

If \mathbf{X} is the matrix with columns taken from the eigenvectors:

$$\mathbf{X} = \begin{pmatrix} x_{11} & x_{12} \\ x_{21} & x_{22} \end{pmatrix},$$

then

$$\det(\mathbf{X}) \neq 0.$$

7.2 Mathematical Induction Review

Mathematical induction is a very powerful tool for proving results. It allows us to prove generalized results. Its shortcoming is that you already have to suspect what the solution is. It then allows you to prove it.

The Principle of Mathematical Induction.

Assume that $P(1), P(2), P(3), \dots$ is an infinite sequence of mathematical statements.

<p>If</p> <p>(a) $P(1)$ is true, and (b) for any k, $P(k)$ implies $P(k+1)$</p> <p>then</p> <p>all the statements in the sequence are true</p>	<p>If</p> <p>first domino falls and if a domino falls, then the next one falls then all dominoes fall!</p>
---	---

Example. For any $n \in \mathbb{N}$, $1 + 3 + 5 + \dots + (2n - 1) = n^2$.

Let us prove this formula using Mathematical Induction.

Proof. If $n = 1$, we get $1 = 1^2$, which is true – $P(1)$ holds.
Assume that $1 + 3 + 5 + \dots + (2k - 1) = k^2$ for some k . Then

$$\begin{aligned}
 1 + 3 + 5 + \dots + (2(k+1) - 1) &= \underbrace{1 + 3 + 5 + \dots + (2k - 1)}_{=k^2 \text{ by induction hypothesis}} + (2k + 1) \\
 &= k^2 + (2k + 1) \\
 &= k^2 + 2k + 1 \\
 &= (k + 1)^2.
 \end{aligned}$$

By induction, the equality holds for all $n \in \mathbb{N}$.

Example.

For any $x \in \mathbb{R}$ with $x \geq -1$ and $n \in \mathbb{N}$, then $(1 + x)^n \geq 1 + nx$. (Bernoulli's Inequality)

Proof. For $n = 1$, $1 + x \geq 1 + x$, which is true!
Assume that $(1 + x)^k \geq 1 + kx$. Then

$$\begin{aligned}
 (1 + x)^{k+1} &= (1 + x)^k(1 + x) \geq (1 + kx)(1 + x) \\
 &= 1 + x + kx^2 + kx = 1 + (k + 1)x + kx^2 \\
 &\geq 1 + (k + 1)x.
 \end{aligned}$$

By induction, the claim holds for all $n \in \mathbb{N}$.

In the proof, we didn't use the fact that $x \geq -1$, but for $n = 3$ and $x = -4$, $(1 + x)^n = -27 \not\geq -11 = 1 + nx$.

Where did we use the hypothesis $x \geq -1$?

Principle of Strong Mathematical Induction.

Assume that $P(1), P(2), P(3), \dots$ is an infinite sequence of mathematical statements.

If	(a) $P(1)$ is true, and (b) For any $k, P(1), \dots, P(k)$ implies $P(k+1)$	If	first domino falls and if all previous dominos fell, then the next one falls
then	all the statements in the sequence are true	then	all dominoes fall!

Example.

Theorem. Every number $n \in \mathbb{N}, n \geq 2$ can be written as a product of primes (or is a prime).

Proof. Base case: $n = 2$ is a prime.

Assume that the Theorem holds for $n = 2, 3, 4, \dots, k$ and consider $n = k + 1$.

If $k + 1$ is prime, the claim holds.

If $k + 1$ is not a prime, then it is divisible by some $2 \leq m \leq k$: $k + 1 = m \cdot \ell$ for some $2 \leq m, \ell \leq k$. By hypothesis, both m and ℓ are products of primes, hence so is $k + 1$. The Theorem follows by strong induction.

Practice Problems

- 1 Is the triangle inequality true for more than two numbers?

$$|x_1 + x_2 + \dots + x_n| \stackrel{?}{\leq} |x_1| + |x_2| + \dots + |x_n|$$

If it is, prove it.

- 2 Is the AGM inequality true for any $x_1, x_2, \dots, x_n \geq 0$?

$$\sqrt[n]{x_1 x_2 \dots x_n} \stackrel{?}{\leq} \frac{x_1 + x_2 + \dots + x_n}{n}$$

If it is, prove it.

- 3 Prove that for any $n \in \mathbb{N}$, $2^{6n} + 3^{2n-2}$ is divisible by 5.

- 4 How many subsets does a set S with n elements have (including S and \emptyset)?

- 5 Show that If $x_1, \dots, x_n \in [0, 1]$ then $\prod_{i=1}^n (1 - x_i) \geq$

$$1 - \sum_{i=1}^n x_i$$

- 6 Can you use Mathematical induction to prove that $P(m), P(m+1), P(m+2), \dots$ are true? If so, how?

- 7 Can you use Mathematical induction to prove that $P(2), P(4), P(6), P(8), \dots$ are true? If so, how?

- 8 Can you use Mathematical induction to prove that $P(1), P(3), P(5), P(7), \dots$ are true? If so, how?

- 9 For which $n \in \mathbb{N}$, $2^n \geq (n+1)^2$? Prove your answer.

- 10 Show that for even n 's, $n(n^2 + 3n + 2)$ is divisible by 24.



- 11 Prove that for any $n \in \mathbb{N}$, a $2^n \times 2^n$ checkerboard with one single square removed has an L-tiling (i.e., can be covered with L-shapes).

- 12 Read the following proof:

Theorem. All horses have the same colour.

Proof. Assume that the claim holds for groups of k horses, and consider a group with $k + 1$ horses $S = \{h_1, \dots, h_{k+1}\}$.

By hypothesis, the horses in $A = \{h_1, \dots, h_k\}$ and $B = \{h_2, \dots, h_{k+1}\}$ have the same colour. Since the horse h_2 is in both groups, we deduce that the colour of the horses in A must be the same as of these in B .

In conclusion, the horses in $S = A \cup B$ must have the same colour, and the claim holds by induction.

This proof is flawed. Explain how.