

Computer Networking: A Top-Down Approach, 7th Edition

Solutions to Review Questions and Problems

Version Date: December 2016

This document contains the solutions to review questions and problems for the 7th edition of *Computer Networking: A Top-Down Approach* by Jim Kurose and Keith Ross. These solutions are being made available to instructors ONLY. Please do NOT copy or distribute this document to others (even other instructors). Please do not post any solutions on a publicly-available Web site. We'll be happy to provide a copy (up-to-date) of this solution manual ourselves to anyone who asks.

Acknowledgments: Over the years, several students and colleagues have helped us prepare this solutions manual. Special thanks goes to Honggang Zhang, Rakesh Kumar, Prithula Dhungel, and Vijay Annapureddy. Also thanks to all the readers who have made suggestions and corrected errors.

All material © copyright 1996-2016 by J.F. Kurose and K.W. Ross. All rights reserved

Chapter 1 Review Questions

1. There is no difference. Throughout this text, the words “host” and “end system” are used interchangeably. End systems include PCs, workstations, Web servers, mail servers, PDAs, Internet-connected game consoles, etc.
2. From Wikipedia: Diplomatic protocol is commonly described as a set of international courtesy rules. These well-established and time-honored rules have made it easier for nations and people to live and work together. Part of protocol has always been the acknowledgment of the hierarchical standing of all present. Protocol rules are based on the principles of civility.
3. Standards are important for protocols so that people can create networking systems and products that interoperate.
4. 1. Dial-up modem over telephone line: home; 2. DSL over telephone line: home or small office; 3. Cable to HFC: home; 4. 100 Mbps switched Ethernet: enterprise; 5. Wifi (802.11): home and enterprise; 6. 3G and 4G: wide-area wireless.
5. HFC bandwidth is shared among the users. On the downstream channel, all packets emanate from a single source, namely, the head end. Thus, there are no collisions in the downstream channel.
6. In most American cities, the current possibilities include: dial-up; DSL; cable modem; fiber-to-the-home.
7. Ethernet LANs have transmission rates of 10 Mbps, 100 Mbps, 1 Gbps and 10 Gbps.
8. Today, Ethernet most commonly runs over twisted-pair copper wire. It also can run over fibers optic links.
9. Dial up modems: up to 56 Kbps, bandwidth is dedicated; ADSL: up to 24 Mbps downstream and 2.5 Mbps upstream, bandwidth is dedicated; HFC, rates up to 42.8 Mbps and upstream rates of up to 30.7 Mbps, bandwidth is shared. FTTH: 2-10Mbps upload; 10-20 Mbps download; bandwidth is not shared.
10. There are two popular wireless Internet access technologies today:
 - a) Wifi (802.11) In a wireless LAN, wireless users transmit/receive packets to/from an base station (i.e., wireless access point) within a radius of few tens of meters. The base station is typically connected to the wired Internet and thus serves to connect wireless users to the wired network.
 - b) 3G and 4G wide-area wireless access networks. In these systems, packets are transmitted over the same wireless infrastructure used for cellular telephony, with the

base station thus being managed by a telecommunications provider. This provides wireless access to users within a radius of tens of kilometers of the base station.

11. At time t_0 the sending host begins to transmit. At time $t_1 = L/R_1$, the sending host completes transmission and the entire packet is received at the router (no propagation delay). Because the router has the entire packet at time t_1 , it can begin to transmit the packet to the receiving host at time t_1 . At time $t_2 = t_1 + L/R_2$, the router completes transmission and the entire packet is received at the receiving host (again, no propagation delay). Thus, the end-to-end delay is $L/R_1 + L/R_2$.
12. A circuit-switched network can guarantee a certain amount of end-to-end bandwidth for the duration of a call. Most packet-switched networks today (including the Internet) cannot make any end-to-end guarantees for bandwidth. FDM requires sophisticated analog hardware to shift signal into appropriate frequency bands.
13. a) 2 users can be supported because each user requires half of the link bandwidth.
b) Since each user requires 1Mbps when transmitting, if two or fewer users transmit simultaneously, a maximum of 2Mbps will be required. Since the available bandwidth of the shared link is 2Mbps, there will be no queuing delay before the link. Whereas, if three users transmit simultaneously, the bandwidth required will be 3Mbps which is more than the available bandwidth of the shared link. In this case, there will be queuing delay before the link.
c) Probability that a given user is transmitting = 0.2
d) Probability that all three users are transmitting simultaneously = $\binom{3}{3} p^3 (1-p)^{3-3}$
= $(0.2)^3 = 0.008$. Since the queue grows when all the users are transmitting, the fraction of time during which the queue grows (which is equal to the probability that all three users are transmitting simultaneously) is 0.008.
14. If the two ISPs do not peer with each other, then when they send traffic to each other they have to send the traffic through a provider ISP (intermediary), to which they have to pay for carrying the traffic. By peering with each other directly, the two ISPs can reduce their payments to their provider ISPs. An Internet Exchange Points (IXP) (typically in a standalone building with its own switches) is a meeting point where multiple ISPs can connect and/or peer together. An ISP earns its money by charging each of the the ISPs that connect to the IXP a relatively small fee, which may depend on the amount of traffic sent to or received from the IXP.
15. Google's private network connects together all its data centers, big and small. Traffic between the Google data centers passes over its private network rather than over the public Internet. Many of these data centers are located in, or close to, lower tier ISPs. Therefore, when Google delivers content to a user, it often can bypass higher tier ISPs. What motivates content providers to create these networks? First, the content

provider has more control over the user experience, since it has to use few intermediary ISPs. Second, it can save money by sending less traffic into provider networks. Third, if ISPs decide to charge more money to highly profitable content providers (in countries where net neutrality doesn't apply), the content providers can avoid these extra payments.

16. The delay components are processing delays, transmission delays, propagation delays, and queuing delays. All of these delays are fixed, except for the queuing delays, which are variable.
17. a) 1000 km, 1 Mbps, 100 bytes
b) 100 km, 1 Mbps, 100 bytes
18. 10msec; d/s; no; no
19. a) 500 kbps
b) 64 seconds
c) 100kbps; 320 seconds
20. End system A breaks the large file into chunks. It adds header to each chunk, thereby generating multiple packets from the file. The header in each packet includes the IP address of the destination (end system B). The packet switch uses the destination IP address in the packet to determine the outgoing link. Asking which road to take is analogous to a packet asking which outgoing link it should be forwarded on, given the packet's destination address.
21. The maximum emission rate is 500 packets/sec and the maximum transmission rate is 350 packets/sec. The corresponding traffic intensity is $500/350 = 1.43 > 1$. Loss will eventually occur for each experiment; but the time when loss first occurs will be different from one experiment to the next due to the randomness in the emission process.
22. Five generic tasks are error control, flow control, segmentation and reassembly, multiplexing, and connection setup. Yes, these tasks can be duplicated at different layers. For example, error control is often provided at more than one layer.
23. The five layers in the Internet protocol stack are – from top to bottom – the application layer, the transport layer, the network layer, the link layer, and the physical layer. The principal responsibilities are outlined in Section 1.5.1.
24. Application-layer message: data which an application wants to send and passed onto the transport layer; transport-layer segment: generated by the transport layer and encapsulates application-layer message with transport layer header; network-layer datagram: encapsulates transport-layer segment with a network-layer header; link-layer frame: encapsulates network-layer datagram with a link-layer header.

25. Routers process network, link and physical layers (layers 1 through 3). (This is a little bit of a white lie, as modern routers sometimes act as firewalls or caching components, and process Transport layer as well.) Link layer switches process link and physical layers (layers 1 through 2). Hosts process all five layers.
26. a) Virus
Requires some form of human interaction to spread. Classic example: E-mail viruses.
- b) Worms
No user replication needed. Worm in infected host scans IP addresses and port numbers, looking for vulnerable processes to infect.
27. Creation of a botnet requires an attacker to find vulnerability in some application or system (e.g. exploiting the buffer overflow vulnerability that might exist in an application). After finding the vulnerability, the attacker needs to scan for hosts that are vulnerable. The target is basically to compromise a series of systems by exploiting that particular vulnerability. Any system that is part of the botnet can automatically scan its environment and propagate by exploiting the vulnerability. An important property of such botnets is that the originator of the botnet can remotely control and issue commands to all the nodes in the botnet. Hence, it becomes possible for the attacker to issue a command to all the nodes, that target a single node (for example, all nodes in the botnet might be commanded by the attacker to send a TCP SYN message to the target, which might result in a TCP SYN flood attack at the target).
28. Trudy can pretend to be Bob to Alice (and vice-versa) and partially or completely modify the message(s) being sent from Bob to Alice. For example, she can easily change the phrase "Alice, I owe you \$1000" to "Alice, I owe you \$10,000". Furthermore, Trudy can even drop the packets that are being sent by Bob to Alice (and vice-versa), even if the packets from Bob to Alice are encrypted.

Chapter 1 Problems

Problem 1

There is no single right answer to this question. Many protocols would do the trick. Here's a simple answer below:

Messages from ATM machine to Server

Msg name	purpose
HELO <userid>	Let server know that there is a card in the ATM machine
PASSWD <passwd>	ATM card transmits user ID to Server
BALANCE	User enters PIN, which is sent to server
WITHDRAWL <amount>	User requests balance
BYE	User asks to withdraw money
	user all done

Messages from Server to ATM machine (display)

Msg name	purpose
PASSWD	Ask user for PIN (password)
OK	last requested operation (PASSWD, WITHDRAWL)
ERR	OK
AMOUNT <amt>	last requested operation (PASSWD, WITHDRAWL) in ERROR
BYE	sent in response to BALANCE request
	user done, display welcome screen at ATM

Correct operation:

client	server
HELO (userid)	-----> (check if valid userid)
	<----- PASSWD
PASSWD <passwd>	-----> (check password)
	<----- OK (password is OK)
BALANCE	----->
	<----- AMOUNT <amt>
WITHDRAWL <amt>	-----> check if enough \$ to cover withdrawl
	<----- OK
ATM dispenses \$	
BYE	----->
	<----- BYE

In situation when there's not enough money:

```

HELO (userid) -----> (check if valid userid)
<----- PASSWD
PASSWD <passwd> -----> (check password)
<----- OK (password is OK)
BALANCE ----->
<----- AMOUNT <amt>
WITHDRAWL <amt> -----> check if enough $ to cover
withdrawl
<----- ERR (not enough funds)
error msg displayed
no $ given out
BYE ----->
<----- BYE

```

Problem 2

At time $N*(L/R)$ the first packet has reached the destination, the second packet is stored in the last router, the third packet is stored in the next-to-last router, etc. At time $N*(L/R) + L/R$, the second packet has reached the destination, the third packet is stored in the last router, etc. Continuing with this logic, we see that at time $N*(L/R) + (P-1)*(L/R) = (N+P-1)*(L/R)$ all packets have reached the destination.

Problem 3

- a) A circuit-switched network would be well suited to the application, because the application involves long sessions with predictable smooth bandwidth requirements. Since the transmission rate is known and not bursty, bandwidth can be reserved for each application session without significant waste. In addition, the overhead costs of setting up and tearing down connections are amortized over the lengthy duration of a typical application session.
- b) In the worst case, all the applications simultaneously transmit over one or more network links. However, since each link has sufficient bandwidth to handle the sum of all of the applications' data rates, no congestion (very little queuing) will occur. Given such generous link capacities, the network does not need congestion control mechanisms.

Problem 4

- a) Between the switch in the upper left and the switch in the upper right we can have 4 connections. Similarly we can have four connections between each of the 3 other pairs of adjacent switches. Thus, this network can support up to 16 connections.
- b) We can 4 connections passing through the switch in the upper-right-hand corner and another 4 connections passing through the switch in the lower-left-hand corner, giving a total of 8 connections.

- c) Yes. For the connections between A and C, we route two connections through B and two connections through D. For the connections between B and D, we route two connections through A and two connections through C. In this manner, there are at most 4 connections passing through any link.

Problem 5

Tollbooths are 75 km apart, and the cars propagate at 100km/hr. A tollbooth services a car at a rate of one car every 12 seconds.

- a) There are ten cars. It takes 120 seconds, or 2 minutes, for the first tollbooth to service the 10 cars. Each of these cars has a propagation delay of 45 minutes (travel 75 km) before arriving at the second tollbooth. Thus, all the cars are lined up before the second tollbooth after 47 minutes. The whole process repeats itself for traveling between the second and third tollbooths. It also takes 2 minutes for the third tollbooth to service the 10 cars. Thus the total delay is 96 minutes.
- b) Delay between tollbooths is $8 \cdot 12$ seconds plus 45 minutes, i.e., 46 minutes and 36 seconds. The total delay is twice this amount plus $8 \cdot 12$ seconds, i.e., 94 minutes and 48 seconds.

Problem 6

- a) $d_{prop} = m / s$ seconds.
- b) $d_{trans} = L / R$ seconds.
- c) $d_{end-to-end} = (m / s + L / R)$ seconds.
- d) The bit is just leaving Host A.
- e) The first bit is in the link and has not reached Host B.
- f) The first bit has reached Host B.
- g) Want

$$m = \frac{L}{R} s = \frac{120}{56 \times 10^3} (2.5 \times 10^8) = 536 \text{ km.}$$

Problem 7

Consider the first bit in a packet. Before this bit can be transmitted, all of the bits in the packet must be generated. This requires

$$\frac{56 \cdot 8}{64 \times 10^3} \text{ sec} = 7 \text{ msec.}$$

The time required to transmit the packet is

$$\frac{56 \cdot 8}{2 \times 10^6} \text{ sec} = 224 \mu \text{ sec}.$$

Propagation delay = 10 msec.
The delay until decoding is

$$7 \text{ msec} + 224 \mu \text{ sec} + 10 \text{ msec} = 17.224 \text{ msec}$$

A similar analysis shows that all bits experience a delay of 17.224 msec.

Problem 8

a) 20 users can be supported.

b) $p = 0.1$.

$$\text{c) } \binom{120}{n} p^n (1-p)^{120-n}.$$

$$\text{d) } 1 - \sum_{n=0}^{20} \binom{120}{n} p^n (1-p)^{120-n}.$$

We use the central limit theorem to approximate this probability. Let X_j be independent random variables such that $P(X_j = 1) = p$.

$$P(\text{“21 or more users”}) = 1 - P\left(\sum_{j=1}^{120} X_j \leq 21\right)$$

$$\begin{aligned} P\left(\sum_{j=1}^{120} X_j \leq 21\right) &= P\left(\frac{\sum_{j=1}^{120} X_j - 12}{\sqrt{120 \cdot 0.1 \cdot 0.9}} \leq \frac{9}{\sqrt{120 \cdot 0.1 \cdot 0.9}}\right) \\ &\approx P\left(Z \leq \frac{9}{3.286}\right) = P(Z \leq 2.74) \\ &= 0.997 \end{aligned}$$

when Z is a standard normal r.v. Thus $P(\text{“21 or more users”}) \approx 0.003$.

Problem 9

a) 10,000

$$\text{b) } \sum_{n=N+1}^M \binom{M}{n} p^n (1-p)^{M-n}$$

Problem 10

The first end system requires L/R_1 to transmit the packet onto the first link; the packet propagates over the first link in d_1/s_1 ; the packet switch adds a processing delay of d_{proc} ; after receiving the entire packet, the packet switch connecting the first and the second link requires L/R_2 to transmit the packet onto the second link; the packet propagates over the second link in d_2/s_2 . Similarly, we can find the delay caused by the second switch and the third link: L/R_3 , d_{proc} , and d_3/s_3 .

Adding these five delays gives

$$d_{end-end} = L/R_1 + L/R_2 + L/R_3 + d_1/s_1 + d_2/s_2 + d_3/s_3 + d_{proc} + d_{proc}$$

To answer the second question, we simply plug the values into the equation to get $6 + 6 + 6 + 20 + 16 + 4 + 3 + 3 = 64$ msec.

Problem 11

Because bits are immediately transmitted, the packet switch does not introduce any delay; in particular, it does not introduce a transmission delay. Thus,

$$d_{end-end} = L/R + d_1/s_1 + d_2/s_2 + d_3/s_3$$

For the values in Problem 10, we get $6 + 20 + 16 + 4 = 46$ msec.

Problem 12

The arriving packet must first wait for the link to transmit $4.5 * 1,500$ bytes = 6,750 bytes or 54,000 bits. Since these bits are transmitted at 2 Mbps, the queuing delay is 27 msec. Generally, the queuing delay is $(nL + (L - x))/R$.

Problem 13

- a) The queuing delay is 0 for the first transmitted packet, L/R for the second transmitted packet, and generally, $(n-1)L/R$ for the n^{th} transmitted packet. Thus, the average delay for the N packets is:

$$\begin{aligned} & (L/R + 2L/R + \dots + (N-1)L/R)/N \\ &= L/(RN) * (1 + 2 + \dots + (N-1)) \\ &= L/(RN) * N(N-1)/2 \\ &= LN(N-1)/(2RN) \\ &= (N-1)L/(2R) \end{aligned}$$

Note that here we used the well-known fact:

$$1 + 2 + \dots + N = N(N+1)/2$$

- b) It takes LN/R seconds to transmit the N packets. Thus, the buffer is empty when a each batch of N packets arrive. Thus, the average delay of a packet across all batches is the average delay within one batch, i.e., $(N-1)L/2R$.

Problem 14

- a) The transmission delay is L/R . The total delay is

$$\frac{IL}{R(1-I)} + \frac{L}{R} = \frac{L/R}{1-I}$$

- b) Let $x = L/R$.

$$\text{Total delay} = \frac{x}{1-ax}$$

For $x=0$, the total delay =0; as we increase x , total delay increases, approaching infinity as x approaches $1/a$.

Problem 15

$$\text{Total delay} = \frac{L/R}{1-I} = \frac{L/R}{1-aL/R} = \frac{1/\mu}{1-a/\mu} = \frac{1}{\mu-a}$$

Problem 16

The total number of packets in the system includes those in the buffer and the packet that is being transmitted. So, $N=10+1$.

Because $N = a \cdot d$, so $(10+1)=a \cdot (\text{queuing delay} + \text{transmission delay})$. That is, $11=a \cdot (0.01+1/100)=a \cdot (0.01+0.01)$. Thus, $a=550$ packets/sec.

Problem 17

- a) There are Q nodes (the source host and the $Q-1$ routers). Let d_{proc}^q denote the processing delay at the q th node. Let R^q be the transmission rate of the q th link and let

$d_{trans}^q = L/R^q$. Let d_{prop}^q be the propagation delay across the q th link. Then

$$d_{end-to-end} = \sum_{q=1}^Q [d_{proc}^q + d_{trans}^q + d_{prop}^q]$$

b) Let d_{queue}^q denote the average queuing delay at node q . Then

$$d_{end-to-end} = \sum_{q=1}^Q [d_{proc}^q + d_{trans}^q + d_{prop}^q + d_{queue}^q].$$

Problem 18

On linux you can use the command

```
traceroute www.targethost.com
```

and in the Windows command prompt you can use

```
tracert www.targethost.com
```

In either case, you will get three delay measurements. For those three measurements you can calculate the mean and standard deviation. Repeat the experiment at different times of the day and comment on any changes.

Here is an example solution:

```
traceroute to www.poly.edu (128.238.24.40), 30 hops max, 40 byte packets
 1 thunder.sdsc.edu (132.249.20.5)  2.802 ms  0.645 ms  0.484 ms
 2 dolphin.sdsc.edu (132.249.31.17)  0.227 ms  0.248 ms  0.239 ms
 3 dc-sdg-aggr1--sdsc-1.cenic.net (137.164.23.129)  0.360 ms  0.260 ms  0.240 ms
 4 dc-riv-core1--sdg-aggr1-10ge-2.cenic.net (137.164.47.14)  8.847 ms  8.497 ms  8.230 ms
 5 dc-lax-core1--lax-core2-10ge-2.cenic.net (137.164.46.64)  9.969 ms  9.920 ms  9.846 ms
 6 dc-lax-px1--lax-core1-10ge-2.cenic.net (137.164.46.151)  9.845 ms  9.729 ms  9.724 ms
 7 hurricane--lax-px1-ge.cenic.net (198.32.251.86)  9.971 ms  16.981 ms  9.850 ms
 8 10gigabitethernet4-3.core1.nyc4.he.net (72.52.92.225)  72.796 ms  80.278 ms  72.346 ms
 9 10gigabitethernet3-4.core1.nyc5.he.net (184.105.213.218)  71.126 ms  71.442 ms  73.623 ms
10 lighttower-fiber-networks.10gigabitethernet3-2.core1.nyc5.he.net (216.66.50.106)  70.924 ms  70.959 ms  71.072 ms
11 ae0.nycmnyzrj91.lighttower.net (72.22.160.156)  70.870 ms  71.089 ms  70.957 ms
12 72.22.188.102 (72.22.188.102)  71.242 ms  71.228 ms  71.102 ms
```

```
traceroute to www.poly.edu (128.238.24.40), 30 hops max, 40 byte packets
 1 thunder.sdsc.edu (132.249.20.5)  0.478 ms  0.353 ms  0.308 ms
 2 dolphin.sdsc.edu (132.249.31.17)  0.212 ms  0.251 ms  0.238 ms
 3 dc-sdg-aggr1--sdsc-1.cenic.net (137.164.23.129)  0.237 ms  0.246 ms  0.240 ms
 4 dc-riv-core1--sdg-aggr1-10ge-2.cenic.net (137.164.47.14)  8.628 ms  8.348 ms  8.357 ms
 5 dc-lax-core1--lax-core2-10ge-2.cenic.net (137.164.46.64)  9.934 ms  9.963 ms  9.852 ms
 6 dc-lax-px1--lax-core1-10ge-2.cenic.net (137.164.46.151)  9.831 ms  9.814 ms  9.676 ms
 7 hurricane--lax-px1-ge.cenic.net (198.32.251.86)  10.194 ms  10.012 ms  16.722 ms
 8 10gigabitethernet4-3.core1.nyc4.he.net (72.52.92.225)  73.856 ms  73.196 ms  73.979 ms
 9 10gigabitethernet3-4.core1.nyc5.he.net (184.105.213.218)  71.247 ms  71.199 ms  71.646 ms
10 lighttower-fiber-networks.10gigabitethernet3-2.core1.nyc5.he.net (216.66.50.106)  70.987 ms  71.073 ms  70.985 ms
11 ae0.nycmnyzrj91.lighttower.net (72.22.160.156)  71.075 ms  71.042 ms  71.328 ms
12 72.22.188.102 (72.22.188.102)  71.626 ms  71.299 ms  72.236 ms
```

```

1 thunder.sdsc.edu (132.249.20.5) 0.403 ms 0.347 ms 0.358 ms
2 dolphin.sdsc.edu (132.249.31.17) 0.225 ms 0.244 ms 0.237 ms
3 dc-sdg-aggl--sdsc-1.cenic.net (137.164.23.129) 0.362 ms 0.256 ms 0.239 ms
4 dc-riv-core1--sdg-aggl-10ge-2.cenic.net (137.164.47.14) 8.850 ms 8.358 ms 8.227 ms
5 dc-lax-core1--lax-core2-10ge-2.cenic.net (137.164.46.64) 10.096 ms 9.869 ms 10.351 ms
6 dc-lax-px1--lax-core1-10ge-2.cenic.net (137.164.46.151) 9.721 ms 9.621 ms 9.725 ms
7 hurricane--lax-px1-ge.cenic.net (198.32.251.86) 11.345 ms 10.048 ms 13.844 ms
8 10gigabitethernet4-3.core1.nyc4.he.net (72.52.92.225) 71.920 ms 72.977 ms 77.264 ms
9 10gigabitethernet3-4.core1.nyc5.he.net (184.105.213.218) 71.273 ms 71.247 ms 71.291 ms
10 lighttower-fiber-networks.10gigabitethernet3-2.core1.nyc5.he.net (216.66.50.106) 71.114 ms 82.516 ms 71.136 ms
11 ae0.nycmnyzrj91.lighttower.net (72.22.160.156) 71.232 ms 71.071 ms 71.039 ms
12 72.22.188.102 (72.22.188.102) 71.585 ms 71.608 ms 71.493 ms

```

Traceroutes between San Diego Super Computer Center and www.poly.edu

- The average (mean) of the round-trip delays at each of the three hours is 71.18 ms, 71.38 ms and 71.55 ms, respectively. The standard deviations are 0.075 ms, 0.21 ms, 0.05 ms, respectively.
- In this example, the traceroutes have 12 routers in the path at each of the three hours. No, the paths didn't change during any of the hours.
- Traceroute packets passed through four ISP networks from source to destination. Yes, in this experiment the largest delays occurred at peering interfaces between adjacent ISPs.

```

traceroute to www.poly.edu (128.238.24.40), 30 hops max, 60 byte packets
1 62-193-36-1.stella-net.net (62.193.36.1) 0.500 ms 0.415 ms 0.440 ms
2 62.193.33.29 (62.193.33.29) 0.910 ms 1.065 ms 1.026 ms
3 bg1.stella-net.net (62.193.32.254) 0.972 ms 1.026 ms 1.078 ms
4 62.193.32.66 (62.193.32.66) 1.021 ms 0.988 ms 0.947 ms
5 10gigabitethernet-2-2.par2.he.net (195.42.144.104) 1.537 ms 1.752 ms 1.714 ms
6 10gigabitethernet7-1.core1.ash1.he.net (184.105.213.93) 80.273 ms 80.103 ms 79.971 ms
7 10gigabitethernet1-2.core1.nyc4.he.net (72.52.92.85) 86.494 ms 85.872 ms 86.223 ms
8 10gigabitethernet3-4.core1.nyc5.he.net (184.105.213.218) 85.248 ms 85.424 ms 85.388 ms
9 lighttower-fiber-networks.10gigabitethernet3-2.core1.nyc5.he.net (216.66.50.106) 86.194 ms 85.864 ms 86.116 ms
10 ae0.nycmnyzrj91.lighttower.net (72.22.160.156) 85.796 ms 85.823 ms 85.766 ms
11 72.22.188.102 (72.22.188.102) 87.717 ms 86.817 ms 86.774 ms

```

```

traceroute to www.poly.edu (128.238.24.40), 30 hops max, 60 byte packets
 1 62-193-36-1.stella-net.net (62.193.36.1) 0.375 ms 0.397 ms 0.355 ms
 2 62.193.33.29 (62.193.33.29) 0.810 ms 0.877 ms 0.836 ms
 3 bg1.stella-net.net (62.193.32.254) 1.098 ms 0.991 ms 1.055 ms
 4 62.193.32.66 (62.193.32.66) 0.994 ms 0.960 ms 1.157 ms
 5 10gigabitethernet-2-2.par2.he.net (195.42.144.104) 1.679 ms 1.816 ms 1.768 ms
 6 10gigabitethernet7-1.core1.ash1.he.net (184.105.213.93) 80.416 ms 90.573 ms 90.659 ms
 7 10gigabitethernet1-2.core1.nyc4.he.net (72.52.92.85) 85.933 ms 95.987 ms 96.087 ms
 8 10gigabitethernet3-4.core1.nyc5.he.net (184.105.213.218) 90.268 ms 90.229 ms 90.030 ms
 9 lighttower-fiber-networks.10gigabitethernet3-2.core1.nyc5.he.net (216.66.50.106) 85.833 ms 85.448 ms 85.418 ms
10 ae0.nycmnyzrj91.lighttower.net (72.22.160.156) 87.067 ms 86.025 ms 85.962 ms
11 72.22.188.102 (72.22.188.102) 86.542 ms 86.369 ms 86.170 ms

```

```

traceroute to 128.238.24.40 (128.238.24.40), 30 hops max, 60 byte packets
 1 62-193-36-1.stella-net.net (62.193.36.1) 0.396 ms 0.284 ms 0.239 ms
 2 62.193.33.29 (62.193.33.29) 0.817 ms 0.786 ms 0.848 ms
 3 bg1.stella-net.net (62.193.32.254) 1.150 ms 1.216 ms 1.265 ms
 4 62.193.32.66 (62.193.32.66) 1.002 ms 0.963 ms 0.923 ms
 5 10gigabitethernet-2-2.par2.he.net (195.42.144.104) 1.573 ms 1.534 ms 1.643 ms
 6 10gigabitethernet7-1.core1.ash1.he.net (184.105.213.93) 88.738 ms 82.866 ms 82.783 ms
 7 10gigabitethernet1-2.core1.nyc4.he.net (72.52.92.85) 94.888 ms 90.936 ms 90.877 ms
 8 10gigabitethernet3-4.core1.nyc5.he.net (184.105.213.218) 90.498 ms 90.543 ms 90.482 ms
 9 lighttower-fiber-networks.10gigabitethernet3-2.core1.nyc5.he.net (216.66.50.106) 85.716 ms 85.408 ms 85.637 ms
10 ae0.nycmnyzrj91.lighttower.net (72.22.160.156) 85.779 ms 85.290 ms 85.252 ms
11 72.22.188.102 (72.22.188.102) 86.217 ms 86.652 ms 86.588 ms

```

Traceroutes from www.stella-net.net (France) to www.poly.edu (USA).

- d) The average round-trip delays at each of the three hours are 87.09 ms, 86.35 ms and 86.48 ms, respectively. The standard deviations are 0.53 ms, 0.18 ms, 0.23 ms, respectively. In this example, there are 11 routers in the path at each of the three hours. No, the paths didn't change during any of the hours. Traceroute packets passed three ISP networks from source to destination. Yes, in this experiment the largest delays occurred at peering interfaces between adjacent ISPs.

Problem 19

An example solution:

```

traceroute to www.poly.edu (128.238.24.30), 30 hops max, 60 byte packets
 1 62-193-36-1.stella-net.net (62.193.36.1) 0.426 ms 0.329 ms 0.284 ms
 2 62.193.33.25 (62.193.33.25) 0.810 ms 0.771 ms 0.878 ms
 3 62.193.32.66 (62.193.32.66) 0.815 ms 0.840 ms 0.801 ms
 4 10gigabitethernet-2-2.par2.he.net (195.42.144.104) 1.387 ms 1.506 ms 1.467 ms
 5 10gigabitethernet7-1.core1.ash1.he.net (184.105.213.93) 85.402 ms 85.553 ms 85.353 ms
 6 10gigabitethernet1-2.core1.nyc4.he.net (72.52.92.85) 94.360 ms 96.220 ms 96.355 ms
 7 10gigabitethernet3-4.core1.nyc5.he.net (184.105.213.218) 90.279 ms 87.459 ms 87.709 ms
 8 lighttower-fiber-networks.10gigabitethernet3-2.core1.nyc5.he.net (216.66.50.106) 85.474 ms 85.450 ms 85.983 ms
 9 ae0.nycmnyzrj91.lighttower.net (72.22.160.156) 86.160 ms 85.768 ms 86.016 ms
10 72.22.188.102 (72.22.188.102) 124.111 ms 89.340 ms 89.556 ms

```

```

 1 vl200.hs01.mar01.jaguar-network.net (85.31.192.253) 0.552 ms 0.414 ms
 2 ae1.cr01.mar01.jaguar-network.net (85.31.194.9) 0.340 ms 0.213 ms
 3 xe2-0-0.cr01.par02.jaguar-network.net (78.153.231.201) 9.933 ms 9.841 ms
 4 te1-3.er01.par02.jaguar-network.net (85.31.194.14) 9.828 ms 9.962 ms
 5 10gigabitethernet-2-2.par2.he.net (195.42.144.104) 10.456 ms 10.332 ms
 6 10gigabitethernet7-1.core1.ash1.he.net (184.105.213.93) 88.793 ms 96.781 ms
 7 10gigabitethernet1-2.core1.nyc4.he.net (72.52.92.85) 94.651 ms 99.654 ms
 8 10gigabitethernet3-4.core1.nyc5.he.net (184.105.213.218) 94.786 ms 94.755 ms
 9 lighttower-fiber-networks.10gigabitethernet3-2.core1.nyc5.he.net (216.66.50.106) 91.935 ms 91.776 ms
10 ae0.nycmnyzrj91.lighttower.net (72.22.160.156) 91.909 ms 91.784 ms
11 72.22.188.102 (72.22.188.102) 93.791 ms 93.515 ms

```

Traceroutes from two different cities in France to New York City in United States

- a) In these traceroutes from two different cities in France to the same destination host in United States, seven links are in common including the transatlantic link.

```

traceroute to www.poly.edu (128.238.24.30), 30 hops max, 60 byte packets
 1
 2 hos-tr3.juniper2.rz10.hetzner.de 213.239.224.65 de 0.224 ms * *
   hos-tr2.juniper1.rz10.hetzner.de 213.239.224.33 de 0.174 ms 0.176 ms
 3 hos-bb1.juniper1.ffm.hetzner.de 213.239.240.224 de 4.746 ms 4.780 ms
   hos-bb1.juniper4.ffm.hetzner.de 213.239.240.230 de 4.823 ms
 4 20gigabitethernet4-3.core1.fra1.he.net 80.81.192.172 de 5.462 ms 5.461 ms 5.456 ms
 5 10gigabitethernet1-4.core1.ams1.he.net 72.52.92.94 us 12.899 ms
   10gigabitethernet5-3.core1.ams1.he.net 72.52.92.77 us 13.197 ms
   10gigabitethernet5-3.core1.lon1.he.net 184.105.213.145 us 26.110 ms
 6 10gigabitethernet1-4.core1.lon1.he.net 72.52.92.81 us 18.720 ms 18.871 ms 18.862 ms
 7 10gigabitethernet7-4.core1.nyc4.he.net 72.52.92.241 us 86.677 ms 85.580 ms 86.560 ms
 8 lighttower-fiber-networks.10gigabitethernet3-2.core1.nyc5.he.net 216.66.50.106 us 118.500 ms
   10gigabitethernet3-4.core1.nyc5.he.net 184.105.213.218 us 90.346 ms
   lighttower-fiber-networks.10gigabitethernet3-2.core1.nyc5.he.net 216.66.50.106 us 118.500 ms
 9 ae0.nycmnyzrj91.lighttower.net 72.22.160.156 us 85.289 ms 85.552 ms 85.283 ms

```

```

traceroute to www.poly.edu (128.238.24.30), 30 hops max, 60 byte packets
 1 62-193-36-1.stella-net.net (62.193.36.1) 0.426 ms 0.329 ms 0.284 ms
 2 62.193.33.25 (62.193.33.25) 0.810 ms 0.771 ms 0.878 ms
 3 62.193.32.66 (62.193.32.66) 0.815 ms 0.840 ms 0.801 ms
 4 10gigabitethernet-2-2.par2.he.net (195.42.144.104) 1.387 ms 1.506 ms 1.467 ms
 5 10gigabitethernet7-1.corel.ash1.he.net (184.105.213.93) 85.402 ms 85.553 ms 85.353 ms
 6 10gigabitethernet1-2.corel.nyc4.he.net (72.52.92.85) 94.360 ms 96.220 ms 96.355 ms
 7 10gigabitethernet3-4.corel.nyc5.he.net (184.105.213.218) 90.279 ms 87.459 ms 87.709 ms
 8 lighttower-fiber-networks.10gigabitethernet3-2.corel.nyc5.he.net (216.66.50.106) 85.474 ms 85.450 ms 85.983 ms
 9 ae0.nycmnyzrj91.lighttower.net (72.22.160.156) 86.160 ms 85.768 ms 86.016 ms
10 72.22.188.102 (72.22.188.102) 124.111 ms 89.340 ms 89.556 ms

```

- b) In this example of traceroutes from one city in France and from another city in Germany to the same host in United States, three links are in common including the transatlantic link.

```

Tracing route to www.autoisp.shu.edu.cn [27.115.83.251]
over a maximum of 30 hops:
 1      9 ms      8 ms      10 ms    10.40.32.1
 2     12 ms     12 ms     9 ms     gig-3-0-4-nycmnyj-rtr1.nyc.rr.com [24.29.119.189]
 3     21 ms     20 ms     22 ms     tenge-0-6-0-0-nyquny91-rtr001.nyc.rr.com [24.29.100.122]
 4     19 ms     21 ms     22 ms     bun6-nyquny91-rtr002.nyc.rr.com [24.29.148.254]
 5     11 ms     11 ms     19 ms     ae-3-0.cr0.nyc20.tbone.rr.com [66.109.6.76]
 6     14 ms     18 ms     14 ms     ae-0-0.pr0.nyc30.tbone.rr.com [66.109.6.159]
 7     14 ms     11 ms     10 ms     xe-9-0-0.edge2.Newark1.Level3.net [4.59.20.29]
 8     12 ms     10 ms     13 ms     ae-31-51.ebr1.Newark1.Level3.net [4.69.156.30]
 9     10 ms     15 ms     13 ms     ae-2-2.ebr1.NewYork1.Level3.net [4.69.132.97]
10     11 ms     17 ms     14 ms     ae-81-81.csw3.NewYork1.Level3.net [4.69.134.74]
11     12 ms     14 ms     11 ms     ae-82-82.ebr2.NewYork1.Level3.net [4.69.148.41]
12     83 ms     83 ms     88 ms     ae-2-2.ebr4.SanJose1.Level3.net [4.69.135.185]
13     91 ms     87 ms     84 ms     ae-71-71.csw2.SanJose1.Level3.net [4.69.153.6]
14     83 ms     83 ms     88 ms     ae-2-70.edge3.SanJose1.Level3.net [4.69.152.82]
15    595 ms     593 ms     600 ms     CHINA-NETCO.edge3.SanJose1.Level3.net [4.79.54.6]
16    594 ms     591 ms     592 ms     219.158.96.213
17    539 ms     540 ms     540 ms     219.158.11.173
18    593 ms     586 ms     585 ms     219.158.19.93
19    585 ms     585 ms     584 ms     219.158.21.246
20    568 ms     587 ms     569 ms     112.64.243.62
21    570 ms     566 ms     568 ms     112.64.243.146
22    342 ms     341 ms     347 ms     112.65.183.106
23    574 ms     571 ms     573 ms     27.115.83.251

Trace complete.

```

```

Tracing route to www.lb.pku.edu.cn [162.105.131.113]
over a maximum of 30 hops:
 1      8 ms      8 ms      8 ms     10.40.32.1
 2     14 ms     9 ms     10 ms     gig-0-3-0-18-nycmnyj-rtr1.nyc.rr.com [24.168.138.85]
 3     21 ms     10 ms     11 ms     tenge-0-6-0-0-nyquny91-rtr001.nyc.rr.com [24.29.100.122]
 4     13 ms     22 ms     22 ms     bun6-nyquny91-rtr002.nyc.rr.com [24.29.148.254]
 5     11 ms     18 ms     12 ms     ae-3-0.cr0.nyc20.tbone.rr.com [66.109.6.76]
 6     43 ms     38 ms     41 ms     ae-8-0.cr0.chi10.tbone.rr.com [66.109.6.25]
 7     86 ms     88 ms     88 ms     ae-6-0.cr0.sjc30.tbone.rr.com [66.109.6.14]
 8     86 ms     89 ms     91 ms     ae-1-0.pr0.sjc10.tbone.rr.com [66.109.6.137]
 9     87 ms     86 ms     86 ms     66.109.10.210
10    257 ms     258 ms     258 ms     ge3-0-0.gw4.hkg3.asianetcom.net [61.14.157.250]
11    298 ms     296 ms     295 ms     CER-0002.gw4.hkg3.asianetcom.net [203.192.137.198]
12    297 ms     305 ms     305 ms     202.112.61.13
13    295 ms     296 ms     296 ms     202.112.61.157
14     *         *         *         Request timed out.
15    298 ms     302 ms     298 ms     202.112.41.178
16    308 ms     300 ms     300 ms     202.112.41.182

```

Traceroutes to two different cities in China from same host in United States

- c) Five links are common in the two traceroutes. The two traceroutes diverge before reaching China

Problem 20

Throughput = $\min\{R_s, R_c, R/M\}$

Problem 21

If only use one path, the max throughput is given by:

$$\max\{\min\{R_1^1, R_2^1, \dots, R_N^1\}, \min\{R_1^2, R_2^2, \dots, R_N^2\}, \dots, \min\{R_1^M, R_2^M, \dots, R_N^M\}\}.$$

If use all paths, the max throughput is given by $\sum_{k=1}^M \min\{R_1^k, R_2^k, \dots, R_N^k\}$.

Problem 22

Probability of successfully receiving a packet is: $p_s = (1-p)^N$.

The number of transmissions needed to be performed until the packet is successfully received by the client is a geometric random variable with success probability p_s . Thus, the average number of transmissions needed is given by: $1/p_s$. Then, the average number of re-transmissions needed is given by: $1/p_s - 1$.

Problem 23

Let's call the first packet A and call the second packet B.

- a) If the bottleneck link is the first link, then packet B is queued at the first link waiting for the transmission of packet A. So the packet inter-arrival time at the destination is simply L/R_s .
- b) If the second link is the bottleneck link and both packets are sent back to back, it must be true that the second packet arrives at the input queue of the second link before the second link finishes the transmission of the first packet. That is,

$$L/R_s + L/R_s + d_{prop} < L/R_s + d_{prop} + L/R_c$$

The left hand side of the above inequality represents the time needed by the second packet to *arrive at* the input queue of the second link (the second link has not started

transmitting the second packet yet). The right hand side represents the time needed by the first packet to finish its transmission onto the second link.

If we send the second packet T seconds later, we will ensure that there is no queuing delay for the second packet at the second link if we have:

$$L/R_s + L/R_s + d_{prop} + T \geq L/R_s + d_{prop} + L/R_c$$

Thus, the minimum value of T is $L/R_c - L/R_s$.

Problem 24

40 terabytes = $40 * 10^{12} * 8$ bits. So, if using the dedicated link, it will take $40 * 10^{12} * 8 / (100 * 10^6) = 3200000$ seconds = 37 days. But with FedEx overnight delivery, you can guarantee the data arrives in one day, and it should cost less than \$100.

Problem 25

- a) 160,000 bits
- b) 160,000 bits
- c) The bandwidth-delay product of a link is the maximum number of bits that can be in the link.
- d) the width of a bit = length of link / bandwidth-delay product, so 1 bit is 125 meters long, which is longer than a football field
- e) s/R

Problem 26

$$s/R=20000\text{km}, \text{ then } R=s/20000\text{km}= 2.5*10^8/(2*10^7)= 12.5 \text{ bps}$$

Problem 27

- a) 80,000,000 bits
- b) 800,000 bits, this is because that the maximum number of bits that will be in the link at any given time = $\min(\text{bandwidth delay product, packet size}) = 800,000$ bits.
- c) .25 meters

Problem 28

- a) $t_{trans} + t_{prop} = 400 \text{ msec} + 80 \text{ msec} = 480 \text{ msec}$.
- b) $20 * (t_{trans} + 2 t_{prop}) = 20*(20 \text{ msec} + 80 \text{ msec}) = 2 \text{ sec}$.

- c) Breaking up a file takes longer to transmit because each data packet and its corresponding acknowledgement packet add their own propagation delays.

Problem 29

Recall geostationary satellite is 36,000 kilometers away from earth surface.

- a) 150 msec
 b) 1,500,000 bits
 c) 600,000,000 bits

Problem 30

Let's suppose the passenger and his/her bags correspond to the data unit arriving to the top of the protocol stack. When the passenger checks in, his/her bags are checked, and a tag is attached to the bags and ticket. This is additional information added in the Baggage layer if Figure 1.20 that allows the Baggage layer to implement the service of separating the passengers and baggage on the sending side, and then reuniting them (hopefully!) on the destination side. When a passenger then passes through security and additional stamp is often added to his/her ticket, indicating that the passenger has passed through a security check. This information is used to ensure (e.g., by later checks for the security information) secure transfer of people.

Problem 31

- a) Time to send message from source host to first packet switch = $\frac{8 \times 10^6}{2 \times 10^6} \text{sec} = 4 \text{sec}$

With store-and-forward switching, the total time to move message from source host to destination host = $4 \text{sec} \times 3 \text{ hops} = 12 \text{sec}$

- b) Time to send 1st packet from source host to first packet switch = $\frac{1 \times 10^4}{2 \times 10^6} \text{sec} = 5 \text{ m sec}$. Time at which 2nd packet is received at the first switch = time at which 1st packet is received at the second switch = $2 \times 5 \text{ m sec} = 10 \text{ m sec}$

- c) Time at which 1st packet is received at the destination host = $5 \text{ m sec} \times 3 \text{ hops} = 15 \text{ m sec}$. After this, every 5msec one packet will be received; thus time at which last (800th) packet is received = $15 \text{ m sec} + 799 * 5 \text{ m sec} = 4.01 \text{sec}$. It can be seen that delay in using message segmentation is significantly less (almost 1/3rd).

- d)
- i. Without message segmentation, if bit errors are not tolerated, if there is a single bit error, the whole message has to be retransmitted (rather than a single packet).
 - ii. Without message segmentation, huge packets (containing HD videos, for example) are sent into the network. Routers have to accommodate these huge

packets. Smaller packets have to queue behind enormous packets and suffer unfair delays.

e)

- i. Packets have to be put in sequence at the destination.
- ii. Message segmentation results in many smaller packets. Since header size is usually the same for all packets regardless of their size, with message segmentation the total amount of header bytes is more.

Problem 32

Yes, the delays in the applet correspond to the delays in the Problem 31. The propagation delays affect the overall end-to-end delays both for packet switching and message switching equally.

Problem 33

There are F/S packets. Each packet is $S=80$ bits. Time at which the last packet is received at the first router is $\frac{S+80}{R} \times \frac{F}{S}$ sec. At this time, the first $F/S-2$ packets are at the destination, and the $F/S-1$ packet is at the second router. The last packet must then be transmitted by the first router and the second router, with each transmission taking $\frac{S+80}{R}$ sec. Thus delay in sending the whole file is $delay = \frac{S+80}{R} \times (\frac{F}{S} + 2)$

To calculate the value of S which leads to the minimum delay,

$$\frac{d}{dS} delay = 0 \Rightarrow S = \sqrt{40F}$$

Problem 34

The circuit-switched telephone networks and the Internet are connected together at "gateways". When a Skype user (connected to the Internet) calls an ordinary telephone, a circuit is established between a gateway and the telephone user over the circuit switched network. The skype user's voice is sent in packets over the Internet to the gateway. At the gateway, the voice signal is reconstructed and then sent over the circuit. In the other direction, the voice signal is sent over the circuit switched network to the gateway. The gateway packetizes the voice signal and sends the voice packets to the Skype user.

Chapter 2 Review Questions

1. The Web: HTTP; file transfer: FTP; remote login: Telnet; e-mail: SMTP; BitTorrent file sharing: BitTorrent protocol
2. Network architecture refers to the organization of the communication process into layers (e.g., the five-layer Internet architecture). Application architecture, on the other hand, is designed by an application developer and dictates the broad structure of the application (e.g., client-server or P2P).
3. The process which initiates the communication is the client; the process that waits to be contacted is the server.
4. No. In a P2P file-sharing application, the peer that is receiving a file is typically the client and the peer that is sending the file is typically the server.
5. The IP address of the destination host and the port number of the socket in the destination process.
6. You would use UDP. With UDP, the transaction can be completed in one roundtrip time (RTT) - the client sends the transaction request into a UDP socket, and the server sends the reply back to the client's UDP socket. With TCP, a minimum of two RTTs are needed - one to set-up the TCP connection, and another for the client to send the request, and for the server to send back the reply.
7. One such example is remote word processing, for example, with Google docs. However, because Google docs runs over the Internet (using TCP), timing guarantees are not provided.
8. a) Reliable data transfer
TCP provides a reliable byte-stream between client and server but UDP does not.

b) A guarantee that a certain value for throughput will be maintained
Neither

c) A guarantee that data will be delivered within a specified amount of time
Neither

d) Confidentiality (via encryption)
Neither
9. SSL operates at the application layer. The SSL socket takes unencrypted data from the application layer, encrypts it and then passes it to the TCP socket. If the application developer wants TCP to be enhanced with SSL, she has to include the SSL code in the application.

10. A protocol uses handshaking if the two communicating entities first exchange control packets before sending data to each other. SMTP uses handshaking at the application layer whereas HTTP does not.
11. The applications associated with those protocols require that all application data be received in the correct order and without gaps. TCP provides this service whereas UDP does not.
12. When the user first visits the site, the server creates a unique identification number, creates an entry in its back-end database, and returns this identification number as a cookie number. This cookie number is stored on the user's host and is managed by the browser. During each subsequent visit (and purchase), the browser sends the cookie number back to the site. Thus the site knows when this user (more precisely, this browser) is visiting the site.
13. Web caching can bring the desired content "closer" to the user, possibly to the same LAN to which the user's host is connected. Web caching can reduce the delay for all objects, even objects that are not cached, since caching reduces the traffic on links.
14. Telnet is not available in Windows 7 by default. to make it available, go to Control Panel, Programs and Features, Turn Windows Features On or Off, Check Telnet client. To start Telnet, in Windows command prompt, issue the following command
> telnet webserverver 80

where "webservice" is some webservice. After issuing the command, you have established a TCP connection between your client telnet program and the web server. Then type in an HTTP GET message. An example is given below:

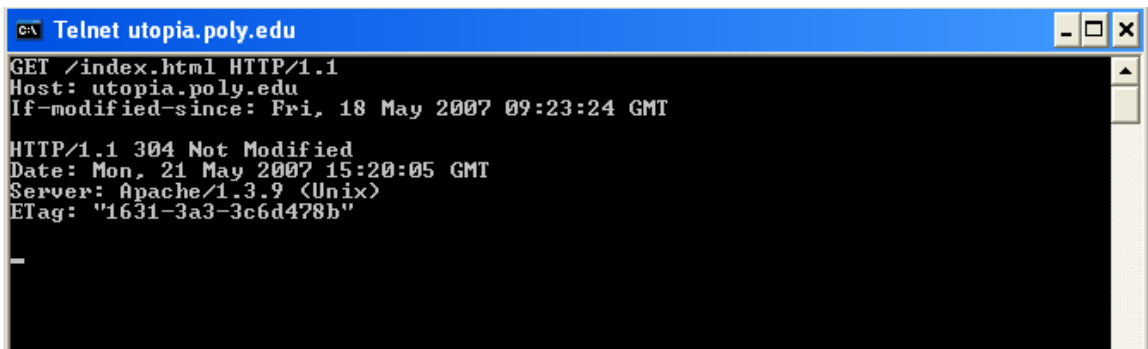

```

c:\ Telnet utopia.poly.edu
GET /index.html HTTP/1.1
Host: utopia.poly.edu
If-modified-since: Fri, 18 May 2007 09:23:24 GMT

HTTP/1.1 304 Not Modified
Date: Mon, 21 May 2007 15:20:05 GMT
Server: Apache/1.3.9 (Unix)
ETag: "1631-3a3-3c6d478b"

-
```

Since the index.html page in this web server was not modified since Fri, 18 May 2007 09:23:34 GMT, and the above commands were issued on Sat, 19 May 2007, the server returned "304 Not Modified". Note that the first 4 lines are the GET message and header lines inputted by the user, and the next 4 lines (starting from HTTP/1.1 304 Not Modified) is the response from the web server.

15. A list of several popular messaging apps: WhatsApp, Facebook Messenger, WeChat, and Snapchat. These apps use the different protocols than SMS.
16. The message is first sent from Alice's host to her mail server over HTTP. Alice's mail server then sends the message to Bob's mail server over SMTP. Bob then transfers the message from his mail server to his host over POP3.
- 17.

Received: from 65.54.246.203 (EHLO bay0-omc3-s3.bay0.hotmail.com) (65.54.246.203) by mta419.mail.mud.yahoo.com with SMTP; Sat, 19 May 2007 16:53:51 -0700

Received: from hotmail.com ([65.55.135.106]) by bay0-omc3-s3.bay0.hotmail.com with Microsoft SMTPSVC(6.0.3790.2668); Sat, 19 May 2007 16:52:42 -0700

Received: from mail pickup service by hotmail.com with Microsoft SMTPSVC; Sat, 19 May 2007 16:52:41 -0700

Message-ID: <BAY130-F26D9E35BF59E0D18A819AFB9310@phx.gbl>

Received: from 65.55.135.123 by by130fd.bay130.hotmail.msn.com with HTTP; Sat, 19 May 2007 23:52:36 GMT

From: "prithula dhungel" <prithuladhungel@hotmail.com>

To: prithula@yahoo.com

Bcc:

Subject: Test mail

Date: Sat, 19 May 2007 23:52:36 +0000

Mime-Version: 1.0

Content-Type: Text/html; format=flowed

Return-Path: prithuladhungel@hotmail.com

Figure: A sample mail message header

Received: This header field indicates the sequence in which the SMTP servers send and receive the mail message including the respective timestamps.

In this example there are 4 "Received:" header lines. This means the mail message passed through 5 different SMTP servers before being delivered to the receiver's mail box. The last (forth) "Received:" header indicates the mail message flow from the SMTP server of the sender to the second SMTP server in the chain of servers. The sender's SMTP server is at address 65.55.135.123 and the second SMTP server in the chain is by130fd.bay130.hotmail.msn.com.

The third "Received:" header indicates the mail message flow from the second SMTP server in the chain to the third server, and so on.

Finally, the first "Received:" header indicates the flow of the mail messages from the forth SMTP server to the last SMTP server (i.e. the receiver's mail server) in the chain.

Message-id: The message has been given this number BAY130-F26D9E35BF59E0D18A819AFB9310@phx.gbl (by bay0-omc3-s3.bay0.hotmail.com. Message-id is a unique string assigned by the mail system when the message is first created.

From: This indicates the email address of the sender of the mail. In the given example, the sender is “prithuladhungel@hotmail.com”

To: This field indicates the email address of the receiver of the mail. In the example, the receiver is “prithula@yahoo.com”

Subject: This gives the subject of the mail (if any specified by the sender). In the example, the subject specified by the sender is “Test mail”

Date: The date and time when the mail was sent by the sender. In the example, the sender sent the mail on 19th May 2007, at time 23:52:36 GMT.

Mime-version: MIME version used for the mail. In the example, it is 1.0.

Content-type: The type of content in the body of the mail message. In the example, it is “text/html”.

Return-Path: This specifies the email address to which the mail will be sent if the receiver of this mail wants to reply to the sender. This is also used by the sender’s mail server for bouncing back undeliverable mail messages of mailer-daemon error messages. In the example, the return path is “prithuladhungel@hotmail.com”.

18. With download and delete, after a user retrieves its messages from a POP server, the messages are deleted. This poses a problem for the nomadic user, who may want to access the messages from many different machines (office PC, home PC, etc.). In the download and keep configuration, messages are not deleted after the user retrieves the messages. This can also be inconvenient, as each time the user retrieves the stored messages from a new machine, all of non-deleted messages will be transferred to the new machine (including very old messages).
19. Yes an organization’s mail server and Web server can have the same alias for a host name. The MX record is used to map the mail server’s host name to its IP address.
20. You should be able to see the sender's IP address for a user with an .edu email address. But you will not be able to see the sender's IP address if the user uses a gmail account.
21. It is not necessary that Bob will also provide chunks to Alice. Alice has to be in the top 4 neighbors of Bob for Bob to send out chunks to her; this might not occur even if Alice provides chunks to Bob throughout a 30-second interval.

22. Recall that in BitTorrent, a peer picks a random peer and optimistically unchokes the peer for a short period of time. Therefore, Alice will eventually be optimistically unchoked by one of her neighbors, during which time she will receive chunks from that neighbor.
23. The overlay network in a P2P file sharing system consists of the nodes participating in the file sharing system and the logical links between the nodes. There is a logical link (an “edge” in graph theory terms) from node A to node B if there is a semi-permanent TCP connection between A and B. An overlay network does not include routers.
24. One server placement philosophy is called Enter Deep, which enter deep into the access networks of Internet Service Providers, by deploying server clusters in access ISPs all over the world. The goal is to reduce delays and increase throughput between end users and the CDN servers. Another philosophy is Bring Home, which bring the ISPs home by building large CDN server clusters at a smaller number of sites and typically placing these server clusters in IXPs (Internet Exchange Points). This Bring Home design typically results in lower maintenance and management cost, compared with the enter-deep design philosophy.
25. Other than network-related factors, there are some important factors to consider, such as load-balancing (clients should not be directed to overload clusters), diurnal effects, variations across DNS servers within a network, limited availability of rarely accessed video, and the need to alleviate hot-spots that may arise due to popular video content.

Reference paper:

Torres, Ruben, et al. "Dissecting video server selection strategies in the YouTube CDN." The 31st IEEE International Conference on Distributed Computing Systems (ICDCS), 2011.

Another factor to consider is ISP delivery cost – the clusters may be chosen so that specific ISPs are used to carry CDN-to-client traffic, taking into account the different cost structures in the contractual relationships between ISPs and cluster operators.

26. With the UDP server, there is no welcoming socket, and all data from different clients enters the server through this one socket. With the TCP server, there is a welcoming socket, and each time a client initiates a connection to the server, a new socket is created. Thus, to support n simultaneous connections, the server would need $n+1$ sockets.
27. For the TCP application, as soon as the client is executed, it attempts to initiate a TCP connection with the server. If the TCP server is not running, then the client will fail to make a connection. For the UDP application, the client does not initiate connections (or attempt to communicate with the UDP server) immediately upon execution

Chapter 2 Problems

Problem 1

- a) F
- b) T
- c) F
- d) F
- e) F

Problem 2

SMS (Short Message Service) is a technology that allows the sending and receiving of text messages between mobile phones over cellular networks. One SMS message can contain data of 140 bytes and it supports languages internationally. The maximum size of a message can be 160 7-bit characters, 140 8-bit characters, or 70 16-bit characters. SMS is realized through the Mobile Application Part (MAP) of the SS#7 protocol, and the Short Message protocol is defined by 3GPP TS 23.040 and 3GPP TS 23.041. In addition, MMS (Multimedia Messaging Service) extends the capability of original text messages, and support sending photos, longer text messages, and other content.

iMessage is an instant messenger service developed by Apple. iMessage supports texts, photos, audios or videos that we send to iOS devices and Macs over cellular data network or WiFi. Apple's iMessage is based on a proprietary, binary protocol APNs (Apple Push Notification Service).

WhatsApp Messenger is an instant messenger service that supports many mobile platforms such as iOS, Android, Mobile Phone, and Blackberry. WhatsApp users can send each other unlimited images, texts, audios, or videos over cellular data network or WiFi. WhatsApp uses the XMPP protocol (Extensible Messaging and Presence Protocol).

iMessage and WhatsApp are different than SMS because they use data plan to send messages and they work on TCP/IP networks, but SMS use the text messaging plan we purchase from our wireless carrier. Moreover, iMessage and WhatsApp support sending photos, videos, files, etc., while the original SMS can only send text message. Finally, iMessage and WhatsApp can work via WiFi, but SMS cannot.

Problem 3

Application layer protocols: DNS and HTTP

Transport layer protocols: UDP for DNS; TCP for HTTP

Problem 4

- a) The document request was `http://gaia.cs.umass.edu/cs453/index.html`. The `Host :` field indicates the server's name and `/cs453/index.html` indicates the file name.
- b) The browser is running HTTP version 1.1, as indicated just before the first `<cr><lf>` pair.
- c) The browser is requesting a persistent connection, as indicated by the `Connection: keep-alive`.
- d) This is a trick question. This information is not contained in an HTTP message anywhere. So there is no way to tell this from looking at the exchange of HTTP messages alone. One would need information from the IP datagrams (that carried the TCP segment that carried the HTTP GET request) to answer this question.
- e) Mozilla/5.0. The browser type information is needed by the server to send different versions of the same object to different types of browsers.

Problem 5

- a) The status code of 200 and the phrase OK indicate that the server was able to locate the document successfully. The reply was provided on Tuesday, 07 Mar 2008 12:39:45 Greenwich Mean Time.
- b) The document `index.html` was last modified on Saturday 10 Dec 2005 18:27:46 GMT.
- c) There are 3874 bytes in the document being returned.
- d) The first five bytes of the returned document are : `<!doc`. The server agreed to a persistent connection, as indicated by the `Connection: Keep-Alive` field

Problem 6

- a) Persistent connections are discussed in section 8 of RFC 2616 (the real goal of this question was to get you to retrieve and read an RFC). Sections 8.1.2 and 8.1.2.1 of the RFC indicate that either the client or the server can indicate to the other that it is going to close the persistent connection. It does so by including the connection-token "close" in the `Connection`-header field of the http request/reply.
- b) HTTP does not provide any encryption services.
- c) (From RFC 2616) "Clients that use persistent connections should limit the number of simultaneous connections that they maintain to a given server. A single-user client SHOULD NOT maintain more than 2 connections with any server or proxy."

- d) Yes. (From RFC 2616) “A client might have started to send a new request at the same time that the server has decided to close the "idle" connection. From the server's point of view, the connection is being closed while it was idle, but from the client's point of view, a request is in progress.”

Problem 7

The total amount of time to get the IP address is

$$RTT_1 + RTT_2 + \dots + RTT_n .$$

Once the IP address is known, RTT_o elapses to set up the TCP connection and another RTT_o elapses to request and receive the small object. The total response time is

$$2RTT_o + RTT_1 + RTT_2 + \dots + RTT_n$$

Problem 8

a)

$$\begin{aligned} & RTT_1 + \dots + RTT_n + 2RTT_o + 8 \cdot 2RTT_o \\ & = 18RTT_o + RTT_1 + \dots + RTT_n . \end{aligned}$$

b)

$$\begin{aligned} & RTT_1 + \dots + RTT_n + 2RTT_o + 2 \cdot 2RTT_o \\ & = 6RTT_o + RTT_1 + \dots + RTT_n \end{aligned}$$

c) Persistent connection with pipelining. This is the default mode of HTTP.

$$\begin{aligned} & RTT_1 + \dots + RTT_n + 2RTT_o + RTT_o \\ & = 3RTT_o + RTT_1 + \dots + RTT_n . \end{aligned}$$

Persistent connection without pipelining, without parallel connections.

$$\begin{aligned} & RTT_1 + \dots + RTT_n + 2RTT_o + 8RTT_o \\ & = 10RTT_o + RTT_1 + \dots + RTT_n . \end{aligned}$$

Problem 9

- a) The time to transmit an object of size L over a link of rate R is L/R . The average time is the average size of the object divided by R :

$$\Delta = (850,000 \text{ bits}) / (15,000,000 \text{ bits/sec}) = .0567 \text{ sec}$$

The traffic intensity on the link is given by $\beta\Delta = (16 \text{ requests/sec})(.0567 \text{ sec/request}) = 0.907$. Thus, the average access delay is $(.0567 \text{ sec}) / (1 - .907) \approx .6 \text{ seconds}$. The total average response time is therefore $.6 \text{ sec} + 3 \text{ sec} = 3.6 \text{ sec}$.

- b) The traffic intensity on the access link is reduced by 60% since the 60% of the requests are satisfied within the institutional network. Thus the average access delay is $(.0567 \text{ sec})/[1 - (.4)(.907)] = .089$ seconds. The response time is approximately zero if the request is satisfied by the cache (which happens with probability .6); the average response time is $.089 \text{ sec} + 3 \text{ sec} = 3.089 \text{ sec}$ for cache misses (which happens 40% of the time). So the average response time is $(.6)(0 \text{ sec}) + (.4)(3.089 \text{ sec}) = 1.24$ seconds. Thus the average response time is reduced from 3.6 sec to 1.24 sec.

Problem 10

Note that each downloaded object can be completely put into one data packet. Let T_p denote the one-way propagation delay between the client and the server.

First consider parallel downloads using non-persistent connections. Parallel downloads would allow 10 connections to share the 150 bits/sec bandwidth, giving each just 15 bits/sec. Thus, the total time needed to receive all objects is given by:

$$\begin{aligned} & (200/150+T_p + 200/150 +T_p + 200/150+T_p + 100,000/150+ T_p) \\ & + (200/(150/10)+T_p + 200/(150/10) +T_p + 200/(150/10)+T_p + 100,000/(150/10)+ T_p) \\ & = 7377 + 8*T_p \text{ (seconds)} \end{aligned}$$

Now consider a persistent HTTP connection. The total time needed is given by:

$$\begin{aligned} & (200/150+T_p + 200/150 +T_p + 200/150+T_p + 100,000/150+ T_p) \\ & + 10*(200/150+T_p + 100,000/150+ T_p) \\ & =7351 + 24*T_p \text{ (seconds)} \end{aligned}$$

Assuming the speed of light is $300*10^6$ m/sec, then $T_p=10/(300*10^6)=0.03$ microsec. T_p is therefore negligible compared with transmission delay.

Thus, we see that persistent HTTP is not significantly faster (less than 1 percent) than the non-persistent case with parallel download.

Problem 11

- Yes, because Bob has more connections, he can get a larger share of the link bandwidth.
- Yes, Bob still needs to perform parallel downloads; otherwise he will get less bandwidth than the other four users.

Problem 12

Server.py

```

from socket import *
serverPort=12000
serverSocket=socket(AF_INET,SOCK_STREAM)
serverSocket.bind(('',serverPort))
serverSocket.listen(1)
connectionSocket, addr = serverSocket.accept()
while 1:
    sentence = connectionSocket.recv(1024)
    print      'From      Server:',      sentence,      '\n'
serverSocket.close()

```

Problem 13

The MAIL FROM: in SMTP is a message from the SMTP client that identifies the sender of the mail message to the SMTP server. The From: on the mail message itself is NOT an SMTP message, but rather is just a line in the body of the mail message.

Problem 14

SMTP uses a line containing only a period to mark the end of a message body. HTTP uses “Content-Length header field” to indicate the length of a message body. No, HTTP cannot use the method used by SMTP, because HTTP message could be binary data, whereas in SMTP, the message body must be in 7-bit ASCII format.

Problem 15

MTA stands for Mail Transfer Agent. A host sends the message to an MTA. The message then follows a sequence of MTAs to reach the receiver’s mail reader. We see that this spam message follows a chain of MTAs. An honest MTA should report where it receives the message. Notice that in this message, “asusus-4b96 ([58.88.21.177])” does not report from where it received the email. Since we assume only the originator is dishonest, so “asusus-4b96 ([58.88.21.177])” must be the originator.

Problem 16

UIDL abbreviates “unique-ID listing”. When a POP3 client issues the UIDL command, the server responds with the unique message ID for all of the messages present in the user's mailbox. This command is useful for “download and keep”. By maintaining a file that lists the messages retrieved during earlier sessions, the client can use the UIDL command to determine which messages on the server have already been seen.

Problem 17

- a) C: dele 1
C: retr 2
S: (blah blah ...
S:blah)
S: .
C: dele 2
C: quit
S: +OK POP3 server signing off
- b) C: retr 2
S: blah blah ...
S:blah
S: .
C: quit
S: +OK POP3 server signing off
- c) C: list
S: 1 498
S: 2 912
S: .
C: retr 1
S: blah
- S:blah
S: .
C: retr 2
S: blah blah ...
S:blah
S: .
C: quit
S: +OK POP3 server signing off

Problem 18

- a) For a given input of domain name (such as ccn.com), IP address or network administrator name, the *whois* database can be used to locate the corresponding registrar, whois server, DNS server, and so on.
- b) NS4.YAHOO.COM from www.register.com; NS1.MSFT.NET from ww.register.com
- c) *Local Domain: www.mindspring.com*
Web servers : www.mindspring.com

207.69.189.21, 207.69.189.22,
207.69.189.23, 207.69.189.24,
207.69.189.25, 207.69.189.26, 207.69.189.27,
207.69.189.28

Mail Servers : mx1.mindspring.com (207.69.189.217)
mx2.mindspring.com (207.69.189.218)
mx3.mindspring.com (207.69.189.219)
mx4.mindspring.com (207.69.189.220)
Name Servers: itchy.earthlink.net (207.69.188.196)
scratchy.earthlink.net (207.69.188.197)

www.yahoo.com

Web Servers: www.yahoo.com (216.109.112.135, 66.94.234.13)
Mail Servers: a.mx.mail.yahoo.com (209.191.118.103)
b.mx.mail.yahoo.com (66.196.97.250)
c.mx.mail.yahoo.com (68.142.237.182, 216.39.53.3)
d.mx.mail.yahoo.com (216.39.53.2)
e.mx.mail.yahoo.com (216.39.53.1)
f.mx.mail.yahoo.com (209.191.88.247, 68.142.202.247)
g.mx.mail.yahoo.com (209.191.88.239, 206.190.53.191)
Name Servers: ns1.yahoo.com (66.218.71.63)
ns2.yahoo.com (68.142.255.16)
ns3.yahoo.com (217.12.4.104)
ns4.yahoo.com (68.142.196.63)
ns5.yahoo.com (216.109.116.17)
ns8.yahoo.com (202.165.104.22)
ns9.yahoo.com (202.160.176.146)

www.hotmail.com

Web Servers: www.hotmail.com (64.4.33.7, 64.4.32.7)
Mail Servers: mx1.hotmail.com (65.54.245.8, 65.54.244.8, 65.54.244.136)
mx2.hotmail.com (65.54.244.40, 65.54.244.168, 65.54.245.40)
mx3.hotmail.com (65.54.244.72, 65.54.244.200, 65.54.245.72)
mx4.hotmail.com (65.54.244.232, 65.54.245.104, 65.54.244.104)
Name Servers: ns1.msft.net (207.68.160.190)
ns2.msft.net (65.54.240.126)
ns3.msft.net (213.199.161.77)
ns4.msft.net (207.46.66.126)
ns5.msft.net (65.55.238.126)

d) The yahoo web server has multiple IP addresses
www.yahoo.com (216.109.112.135, 66.94.234.13)

e) The address range for Polytechnic University: 128.238.0.0 – 128.238.255.255

- f) An attacker can use the *whois* database and nslookup tool to determine the IP address ranges, DNS server addresses, etc., for the target institution.
- g) By analyzing the source address of attack packets, the victim can use whois to obtain information about domain from which the attack is coming and possibly inform the administrators of the origin domain.

Problem 19

- a) The following delegation chain is used for gaia.cs.umass.edu
a.root-servers.net
E.GTLD-SERVERS.NET
ns1.umass.edu(authoritative)

First command:

```
dig +norecurse @a.root-servers.net any gaia.cs.umass.edu
```

```
;; AUTHORITY SECTION:
```

```
edu.          172800 IN    NS    E.GTLD-SERVERS.NET.
edu.          172800 IN    NS    A.GTLD-SERVERS.NET.
edu.          172800 IN    NS    G3.NSTLD.COM.
edu.          172800 IN    NS    D.GTLD-SERVERS.NET.
edu.          172800 IN    NS    H3.NSTLD.COM.
edu.          172800 IN    NS    L3.NSTLD.COM.
edu.          172800 IN    NS    M3.NSTLD.COM.
edu.          172800 IN    NS    C.GTLD-SERVERS.NET.
```

Among all returned edu DNS servers, we send a query to the first one.

```
dig +norecurse @E.GTLD-SERVERS.NET any gaia.cs.umass.edu
```

```
umass.edu.    172800 IN    NS    ns1.umass.edu.
umass.edu.    172800 IN    NS    ns2.umass.edu.
umass.edu.    172800 IN    NS    ns3.umass.edu.
```

Among all three returned authoritative DNS servers, we send a query to the first one.

```
dig +norecurse @ns1.umass.edu any gaia.cs.umass.edu
```

```
gaia.cs.umass.edu. 21600 IN    A     128.119.245.12
```

- b) The answer for google.com could be:
a.root-servers.net
E.GTLD-SERVERS.NET
ns1.google.com(authoritative)

Problem 20

We can periodically take a snapshot of the DNS caches in the local DNS servers. The Web server that appears most frequently in the DNS caches is the most popular server. This is because if more users are interested in a Web server, then DNS requests for that server are more frequently sent by users. Thus, that Web server will appear in the DNS caches more frequently.

For a complete measurement study, see:

Craig E. Wills, Mikhail Mikhailov, Hao Shang

“Inferring Relative Popularity of Internet Applications by Actively Querying DNS Caches”, in IMC'03, October 27-29, 2003, Miami Beach, Florida, USA

Problem 21

Yes, we can use dig to query that Web site in the local DNS server.

For example, “dig cnn.com” will return the query time for finding cnn.com. If cnn.com was just accessed a couple of seconds ago, an entry for cnn.com is cached in the local DNS cache, so the query time is 0 msec. Otherwise, the query time is large.

Problem 22

For calculating the minimum distribution time for client-server distribution, we use the following formula:

$$D_{cs} = \max \{NF/u_s, F/d_{min}\}$$

Similarly, for calculating the minimum distribution time for P2P distribution, we use the following formula:

$$D_{P2P} = \max \{F/u_s, F/d_{min}, NF/(u_s + \sum_{i=1}^N u_i)\}$$

Where, $F = 15 \text{ Gbits} = 15 * 1024 \text{ Mbits}$

$u_s = 30 \text{ Mbps}$

$d_{min} = d_i = 2 \text{ Mbps}$

Note, 300Kbps = 300/1024 Mbps.

Client Server

	N			
	10	100	1000	
u	300 Kbps	7680	51200	512000
	700 Kbps	7680	51200	512000
	2 Mbps	7680	51200	512000

Peer to Peer

		N		
		10	100	1000
u	300 Kbps	7680	25904	47559
	700 Kbps	7680	15616	21525
	2 Mbps	7680	7680	7680

Problem 23

- a) Consider a distribution scheme in which the server sends the file to each client, in parallel, at a rate of a rate of u_s/N . Note that this rate is less than each of the client's download rate, since by assumption $u_s/N \leq d_{\min}$. Thus each client can also receive at rate u_s/N . Since each client receives at rate u_s/N , the time for each client to receive the entire file is $F/(u_s/N) = NF/u_s$. Since all the clients receive the file in NF/u_s , the overall distribution time is also NF/u_s .
- b) Consider a distribution scheme in which the server sends the file to each client, in parallel, at a rate of d_{\min} . Note that the aggregate rate, $N d_{\min}$, is less than the server's link rate u_s , since by assumption $u_s/N \geq d_{\min}$. Since each client receives at rate d_{\min} , the time for each client to receive the entire file is F/d_{\min} . Since all the clients receive the file in this time, the overall distribution time is also F/d_{\min} .
- c) From Section 2.6 we know that

$$D_{CS} \geq \max \{NF/u_s, F/d_{\min}\} \quad (\text{Equation 1})$$

Suppose that $u_s/N \leq d_{\min}$. Then from Equation 1 we have $D_{CS} \geq NF/u_s$. But from (a) we have $D_{CS} \leq NF/u_s$. Combining these two gives:

$$D_{CS} = NF/u_s \text{ when } u_s/N \leq d_{\min}. \quad (\text{Equation 2})$$

We can similarly show that:

$$D_{CS} = F/d_{\min} \text{ when } u_s/N \geq d_{\min} \quad (\text{Equation 3}).$$

Combining Equation 2 and Equation 3 gives the desired result.

Problem 24

- a) Define $u = u_1 + u_2 + \dots + u_N$. By assumption

$$u_s \leq (u_s + u)/N \quad \text{Equation 1}$$

Divide the file into N parts, with the i^{th} part having size $(u_i/u)F$. The server transmits the i^{th} part to peer i at rate $r_i = (u_i/u)u_s$. Note that $r_1 + r_2 + \dots + r_N = u_s$, so that the aggregate server rate does not exceed the link rate of the server. Also have each peer i forward the bits it receives to each of the $N-1$ peers at rate r_i . The aggregate forwarding rate by peer i is $(N-1)r_i$. We have

$$(N-1)r_i = (N-1)(u_i u_s)/u \leq u_i,$$

where the last inequality follows from Equation 1. Thus the aggregate forwarding rate of peer i is less than its link rate u_i .

In this distribution scheme, peer i receives bits at an aggregate rate of

$$r_i + \sum_{j < i} r_j = u_s$$

Thus each peer receives the file in F/u_s .

b) Again define $u = u_1 + u_2 + \dots + u_N$. By assumption

$$u_s \geq (u_s + u)/N \quad \text{Equation 2}$$

$$\text{Let } r_i = u_i/(N-1) \text{ and} \\ r_{N+1} = (u_s - u/(N-1))/N$$

In this distribution scheme, the file is broken into $N+1$ parts. The server sends bits from the i^{th} part to the i^{th} peer ($i = 1, \dots, N$) at rate r_i . Each peer i forwards the bits arriving at rate r_i to each of the other $N-1$ peers. Additionally, the server sends bits from the $(N+1)^{\text{st}}$ part at rate r_{N+1} to each of the N peers. The peers do not forward the bits from the $(N+1)^{\text{st}}$ part.

The aggregate send rate of the server is

$$r_1 + \dots + r_N + N r_{N+1} = u/(N-1) + u_s - u/(N-1) = u_s$$

Thus, the server's send rate does not exceed its link rate. The aggregate send rate of peer i is

$$(N-1)r_i = u_i$$

Thus, each peer's send rate does not exceed its link rate.

In this distribution scheme, peer i receives bits at an aggregate rate of

$$r_i + r_{N+1} + \sum_{j < i} r_j = u/(N-1) + (u_s - u/(N-1))/N = (u_s + u)/N$$

Thus each peer receives the file in $NF/(u_s+u)$.

(For simplicity, we neglected to specify the size of the file part for $i = 1, \dots, N+1$. We now provide that here. Let $\Delta = (u_s+u)/N$ be the distribution time. For $i = 1, \dots, N$, the i^{th} file part is $F_i = r_i \Delta$ bits. The $(N+1)^{\text{st}}$ file part is $F_{N+1} = r_{N+1} \Delta$ bits. It is straightforward to show that $F_1 + \dots + F_{N+1} = F$.)

- c) The solution to this part is similar to that of 17 (c). We know from section 2.6 that

$$D_{P2P} \geq \max\{F/u_s, NF/(u_s + u)\}$$

Combining this with a) and b) gives the desired result.

Problem 25

There are N nodes in the overlay network. There are $N(N-1)/2$ edges.

Problem 26

Yes. His first claim is possible, as long as there are enough peers staying in the swarm for a long enough time. Bob can always receive data through optimistic unchoking by other peers.

His second claim is also true. He can run a client on each host, let each client “free-ride,” and combine the collected chunks from the different hosts into a single file. He can even write a small scheduling program to make the different hosts ask for different chunks of the file. This is actually a kind of Sybil attack in P2P networks.

Problem 27

- a. N files, under the assumption that we do a one-to-one matching by pairing video versions with audio versions in a decreasing order of quality and rate.
- b. $2N$ files.

Problem 28

- a) If you run TCPClient first, then the client will attempt to make a TCP connection with a non-existent server process. A TCP connection will not be made.
- b) UDPClient doesn't establish a TCP connection with the server. Thus, everything should work fine if you first run UDPClient, then run UDPServer, and then type some input into the keyboard.

- c) If you use different port numbers, then the client will attempt to establish a TCP connection with the wrong process or a non-existent process. Errors will occur.

Problem 29

In the original program, UDPClient does not specify a port number when it creates the socket. In this case, the code lets the underlying operating system choose a port number. With the additional line, when UDPClient is executed, a UDP socket is created with port number 5432 .

UDPServer needs to know the client port number so that it can send packets back to the correct client socket. Glancing at UDPServer, we see that the client port number is not “hard-wired” into the server code; instead, UDPServer determines the client port number by unraveling the datagram it receives from the client. Thus UDP server will work with any client port number, including 5432. UDPServer therefore does not need to be modified.

Before:

Client socket = x (chosen by OS)
Server socket = 9876

After:

Client socket = 5432

Problem 30

Yes, you can configure many browsers to open multiple simultaneous connections to a Web site. The advantage is that you will potentially download the file faster. The disadvantage is that you may be hogging the bandwidth, thereby significantly slowing down the downloads of other users who are sharing the same physical links.

Problem 31

For an application such as remote login (telnet and ssh), a byte-stream oriented protocol is very natural since there is no notion of message boundaries in the application. When a user types a character, we simply drop the character into the TCP connection.

In other applications, we may be sending a series of messages that have inherent boundaries between them. For example, when one SMTP mail server sends another SMTP mail server several email messages back to back. Since TCP does not have a mechanism to indicate the boundaries, the application must add the indications itself, so that receiving side of the application can distinguish one message from the next. If each message were instead put into a distinct UDP segment, the receiving end would be able to

distinguish the various messages without any indications added by the sending side of the application.

Problem 32

To create a web server, we need to run web server software on a host. Many vendors sell web server software. However, the most popular web server software today is Apache, which is open source and free. Over the years it has been highly optimized by the open-source community.

Chapter 3 Review Questions

1.
 - a) Call this protocol Simple Transport Protocol (STP). At the sender side, STP accepts from the sending process a chunk of data not exceeding 1196 bytes, a destination host address, and a destination port number. STP adds a four-byte header to each chunk and puts the port number of the destination process in this header. STP then gives the destination host address and the resulting segment to the network layer. The network layer delivers the segment to STP at the destination host. STP then examines the port number in the segment, extracts the data from the segment, and passes the data to the process identified by the port number.
 - b) The segment now has two header fields: a source port field and destination port field. At the sender side, STP accepts a chunk of data not exceeding 1192 bytes, a destination host address, a source port number, and a destination port number. STP creates a segment which contains the application data, source port number, and destination port number. It then gives the segment and the destination host address to the network layer. After receiving the segment, STP at the receiving host gives the application process the application data and the source port number.
 - c) No, the transport layer does not have to do anything in the core; the transport layer “lives” in the end systems.
2.
 1. For sending a letter, the family member is required to give the delegate the letter itself, the address of the destination house, and the name of the recipient. The delegate clearly writes the recipient’s name on the top of the letter. The delegate then puts the letter in an envelope and writes the address of the destination house on the envelope. The delegate then gives the letter to the planet’s mail service. At the receiving side, the delegate receives the letter from the mail service, takes the letter out of the envelope, and takes note of the recipient name written at the top of the letter. The delegate then gives the letter to the family member with this name.
 2. No, the mail service does not have to open the envelope; it only examines the address on the envelope.
 3. Source port number y and destination port number x .
 4. An application developer may not want its application to use TCP’s congestion control, which can throttle the application’s sending rate at times of congestion. Often, designers of IP telephony and IP videoconference applications choose to run their applications over UDP because they want to avoid TCP’s congestion control. Also, some applications do not need the reliable data transfer provided by TCP.

5. Since most firewalls are configured to block UDP traffic, using TCP for video and voice traffic lets the traffic through the firewalls.
6. Yes. The application developer can put reliable data transfer into the application layer protocol. This would require a significant amount of work and debugging, however.
7. Yes, both segments will be directed to the same socket. For each received segment, at the socket interface, the operating system will provide the process with the IP addresses to determine the origins of the individual segments.
8. For each persistent connection, the Web server creates a separate “connection socket”. Each connection socket is identified with a four-tuple: (source IP address, source port number, destination IP address, destination port number). When host C receives an IP datagram, it examines these four fields in the datagram/segment to determine to which socket it should pass the payload of the TCP segment. Thus, the requests from A and B pass through different sockets. The identifier for both of these sockets has 80 for the destination port; however, the identifiers for these sockets have different values for source IP addresses. Unlike UDP, when the transport layer passes a TCP segment’s payload to the application process, it does not specify the source IP address, as this is implicitly specified by the socket identifier.
9. Sequence numbers are required for a receiver to find out whether an arriving packet contains new data or is a retransmission.
10. To handle losses in the channel. If the ACK for a transmitted packet is not received within the duration of the timer for the packet, the packet (or its ACK or NACK) is assumed to have been lost. Hence, the packet is retransmitted.
11. A timer would still be necessary in the protocol rdt 3.0. If the round trip time is known then the only advantage will be that, the sender knows for sure that either the packet or the ACK (or NACK) for the packet has been lost, as compared to the real scenario, where the ACK (or NACK) might still be on the way to the sender, after the timer expires. However, to detect the loss, for each packet, a timer of constant duration will still be necessary at the sender.
12.
 - a) The packet loss caused a time out after which all the five packets were retransmitted.
 - b) Loss of an ACK didn’t trigger any retransmission as Go-Back-N uses cumulative acknowledgements.
 - c) The sender was unable to send sixth packet as the send window size is fixed to 5.

13.

- a) When the packet was lost, the received four packets were buffered the receiver. After the timeout, sender retransmitted the lost packet and receiver delivered the buffered packets to application in correct order.
- b) Duplicate ACK was sent by the receiver for the lost ACK.
- c) The sender was unable to send sixth packet as the send window size is fixed to 5

When a packet was lost, GO-Back-N retransmitted all the packets whereas Selective Repeat retransmitted the lost packet only. In case of lost acknowledgement, selective repeat sent a duplicate ACK and as GO-Back-N used cumulative acknowledgment, so that duplicate ACK was unnecessary.

14. a) false b) false c) true d) false e) true f) false g) false

15. a) 20 bytes b) ack number = 90

16. 3 segments. First segment: seq = 43, ack = 80; Second segment: seq = 80, ack = 44; Third segment; seq = 44, ack = 81

17. R/2

18. False, it is set to half of the current value of the congestion window.

19. Let $X = RTT_{FE}$, $Y = RTT_{BE}$ and $ST =$ Search time. Consider the following timing diagram.

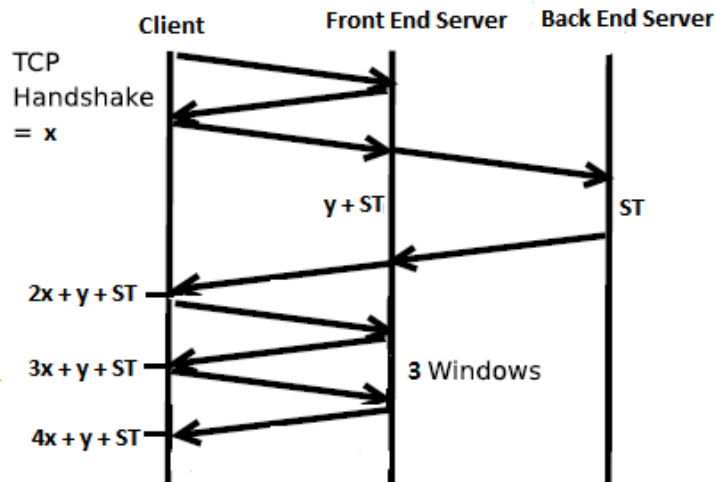

TCP packet exchange diagram between a client and a server (Back End) with a proxy (Front End) between them.

From this diagram we see that the total time is $4X + Y + ST = 4 \cdot RTT_{FE} + RTT_{BE} + \text{Search time}$

Chapter 3 Problems

Problem 1

	source port numbers	destination port numbers
a) A → S	467	23
b) B → S	513	23
c) S → A	23	467
d) S → B	23	513

e) Yes.

f) No.

Problem 2

Suppose the IP addresses of the hosts A, B, and C are a, b, c, respectively. (Note that a, b, c are distinct.)

To host A: Source port = 80, source IP address = b, dest port = 26145, dest IP address = a

To host C, left process: Source port = 80, source IP address = b, dest port = 7532, dest IP address = c

To host C, right process: Source port = 80, source IP address = b, dest port = 26145, dest IP address = c

Problem 3

Note, wrap around if overflow.

$$\begin{array}{r}
 0\ 1\ 0\ 1\ 0\ 0\ 1\ 1 \\
 +\ 0\ 1\ 1\ 0\ 0\ 1\ 1\ 0 \\
 \hline
 1\ 0\ 1\ 1\ 1\ 0\ 0\ 1
 \end{array}$$

$$\begin{array}{r}
 1\ 0\ 1\ 1\ 1\ 0\ 0\ 1 \\
 +\ 0\ 1\ 1\ 1\ 0\ 1\ 0\ 0 \\
 \hline
 0\ 0\ 1\ 0\ 1\ 1\ 1\ 0
 \end{array}$$

One's complement = 1 1 0 1 0 0 0 1.

To detect errors, the receiver adds the four words (the three original words and the checksum). If the sum contains a zero, the receiver knows there has been an error. All one-bit errors will be detected, but two-bit errors can be undetected (e.g., if the last digit of the first word is converted to a 0 and the last digit of the second word is converted to a 1).

Problem 4

- a) Adding the two bytes gives 11000001. Taking the one's complement gives 00111110.
- b) Adding the two bytes gives 01000000; the one's complement gives 10111111.
- c) First byte = 01010100; second byte = 01101101.

Problem 5

No, the receiver cannot be absolutely certain that no bit errors have occurred. This is because of the manner in which the checksum for the packet is calculated. If the corresponding bits (that would be added together) of two 16-bit words in the packet were 0 and 1 then even if these get flipped to 1 and 0 respectively, the sum still remains the same. Hence, the 1s complement the receiver calculates will also be the same. This means the checksum will verify even if there was transmission error.

Problem 6

Suppose the sender is in state "Wait for call 1 from above" and the receiver (the receiver shown in the homework problem) is in state "Wait for 1 from below." The sender sends a packet with sequence number 1, and transitions to "Wait for ACK or NAK 1," waiting for an ACK or NAK. Suppose now the receiver receives the packet with sequence number 1 correctly, sends an ACK, and transitions to state "Wait for 0 from below," waiting for a data packet with sequence number 0. However, the ACK is corrupted. When the rdt2.1 sender gets the corrupted ACK, it resends the packet with sequence number 1. However, the receiver is waiting for a packet with sequence number 0 and (as shown in the home work problem) always sends a NAK when it doesn't get a packet with sequence number 0. Hence the sender will always be sending a packet with sequence number 1, and the receiver will always be NAKing that packet. Neither will progress forward from that state.

Problem 7

To best answer this question, consider why we needed sequence numbers in the first place. We saw that the sender needs sequence numbers so that the receiver can tell if a data packet is a duplicate of an already received data packet. In the case of ACKs, the sender does not need this info (i.e., a sequence number on an ACK) to tell detect a duplicate ACK. A duplicate ACK is obvious to the rdt3.0 receiver, since when it has received the original ACK it transitioned to the next state. The duplicate ACK is not the ACK that the sender needs and hence is ignored by the rdt3.0 sender.

Problem 8

The sender side of protocol rdt3.0 differs from the sender side of protocol 2.2 in that timeouts have been added. We have seen that the introduction of timeouts adds the possibility of duplicate packets into the sender-to-receiver data stream. However, the receiver in protocol rdt.2.2 can already handle duplicate packets. (Receiver-side duplicates in rdt 2.2 would arise if the receiver sent an ACK that was lost, and the sender then retransmitted the old data). Hence the receiver in protocol rdt2.2 will also work as the receiver in protocol rdt 3.0.

Problem 9

Suppose the protocol has been in operation for some time. The sender is in state “Wait for call from above” (top left hand corner) and the receiver is in state “Wait for 0 from below”. The scenarios for corrupted data and corrupted ACK are shown in Figure 1.

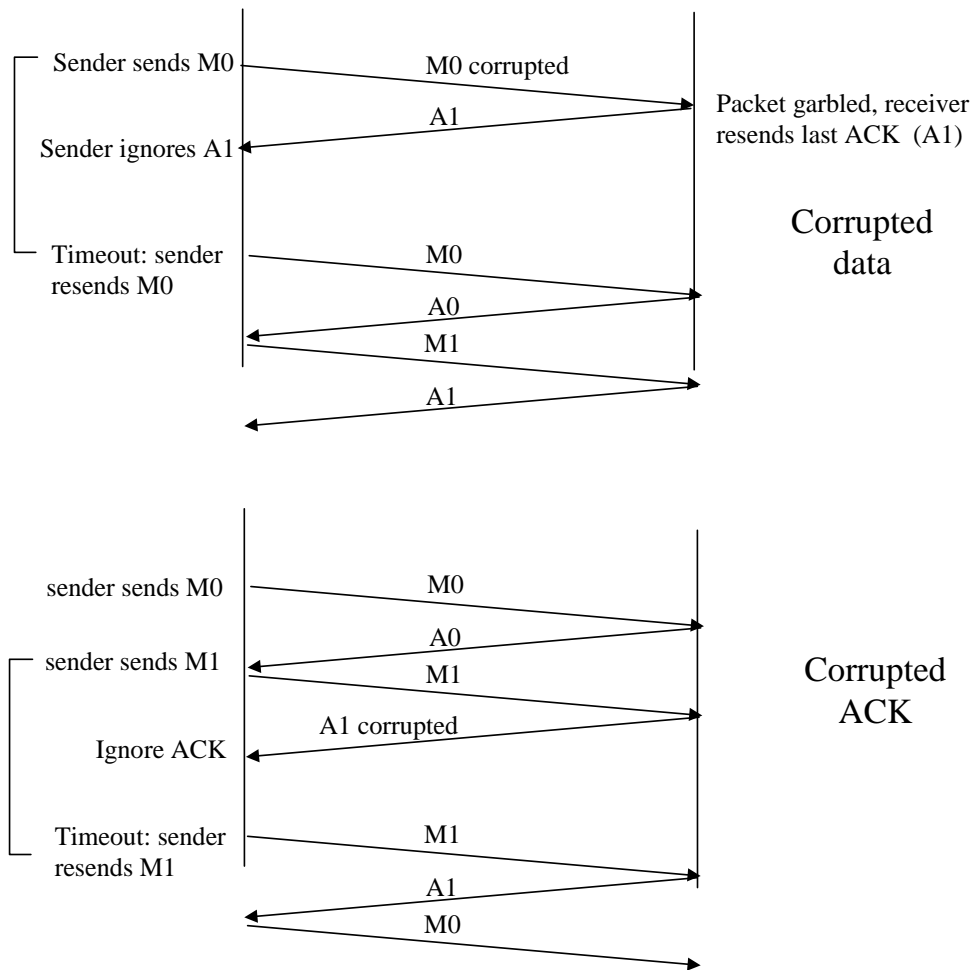

Figure 1: rdt 3.0 scenarios: corrupted data, corrupted ACK

Problem 10

Here, we add a timer, whose value is greater than the known round-trip propagation delay. We add a timeout event to the “Wait for ACK or NAK0” and “Wait for ACK or NAK1” states. If the timeout event occurs, the most recently transmitted packet is retransmitted. Let us see why this protocol will still work with the rdt2.1 receiver.

- Suppose the timeout is caused by a lost data packet, i.e., a packet on the sender-to-receiver channel. In this case, the receiver never received the previous transmission and, from the receiver's viewpoint, if the timeout retransmission is received, it looks *exactly* the same as if the original transmission is being received.
- Suppose now that an ACK is lost. The receiver will eventually retransmit the packet on a timeout. But a retransmission is exactly the same action that if an ACK is garbled. Thus the sender's reaction is the same with a loss, as with a garbled ACK. The rdt 2.1 receiver can already handle the case of a garbled ACK.

Problem 11

If the sending of this message were removed, the sending and receiving sides would deadlock, waiting for an event that would never occur. Here's a scenario:

- Sender sends pkt0, enter the "Wait for ACK0 state", and waits for a packet back from the receiver
- Receiver is in the "Wait for 0 from below" state, and receives a corrupted packet from the sender. Suppose it does not send anything back, and simply re-enters the 'wait for 0 from below' state.

Now, the sender is awaiting an ACK of some sort from the receiver, and the receiver is waiting for a data packet from the sender – a deadlock!

Problem 12

The protocol would still work, since a retransmission would be what would happen if the packet received with errors has actually been lost (and from the receiver standpoint, it never knows which of these events, if either, will occur).

To get at the more subtle issue behind this question, one has to allow for premature timeouts to occur. In this case, if each extra copy of the packet is ACKed and each received extra ACK causes another extra copy of the current packet to be sent, the number of times packet n is sent will increase without bound as n approaches infinity.

Problem 13

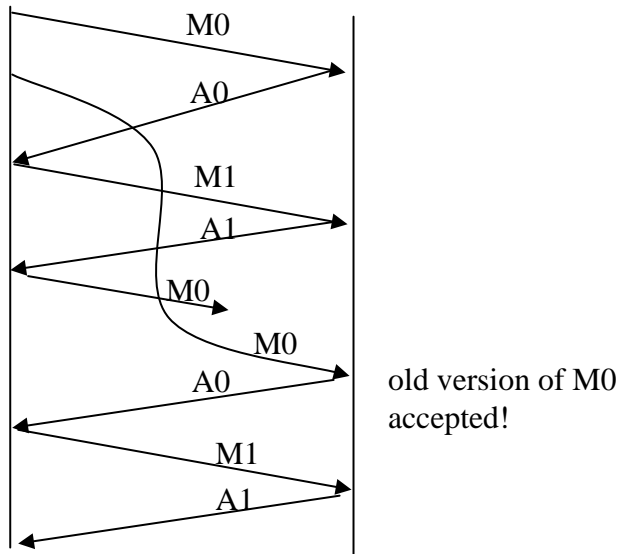

Problem 14

In a NAK only protocol, the loss of packet x is only detected by the receiver when packet $x+1$ is received. That is, the receiver receives $x-1$ and then $x+1$, only when $x+1$ is received does the receiver realize that x was missed. If there is a long delay between the transmission of x and the transmission of $x+1$, then it will be a long time until x can be recovered, under a NAK only protocol.

On the other hand, if data is being sent often, then recovery under a NAK-only scheme could happen quickly. Moreover, if errors are infrequent, then NAKs are only occasionally sent (when needed), and ACK are never sent – a significant reduction in feedback in the NAK-only case over the ACK-only case.

Problem 15

It takes 12 microseconds (or 0.012 milliseconds) to send a packet, as $1500 \cdot 8 / 10^9 = 12$ microseconds. In order for the sender to be busy 98 percent of the time, we must have

$$util = 0.98 = (0.012n) / 30.012$$

or n approximately 2451 packets.

Problem 16

Yes. This actually causes the sender to send a number of pipelined data into the channel.

Yes. Here is one potential problem. If data segments are lost in the channel, then the sender of rdt 3.0 won't re-send those segments, unless there are some additional mechanism in the application to recover from loss.

Problem 17

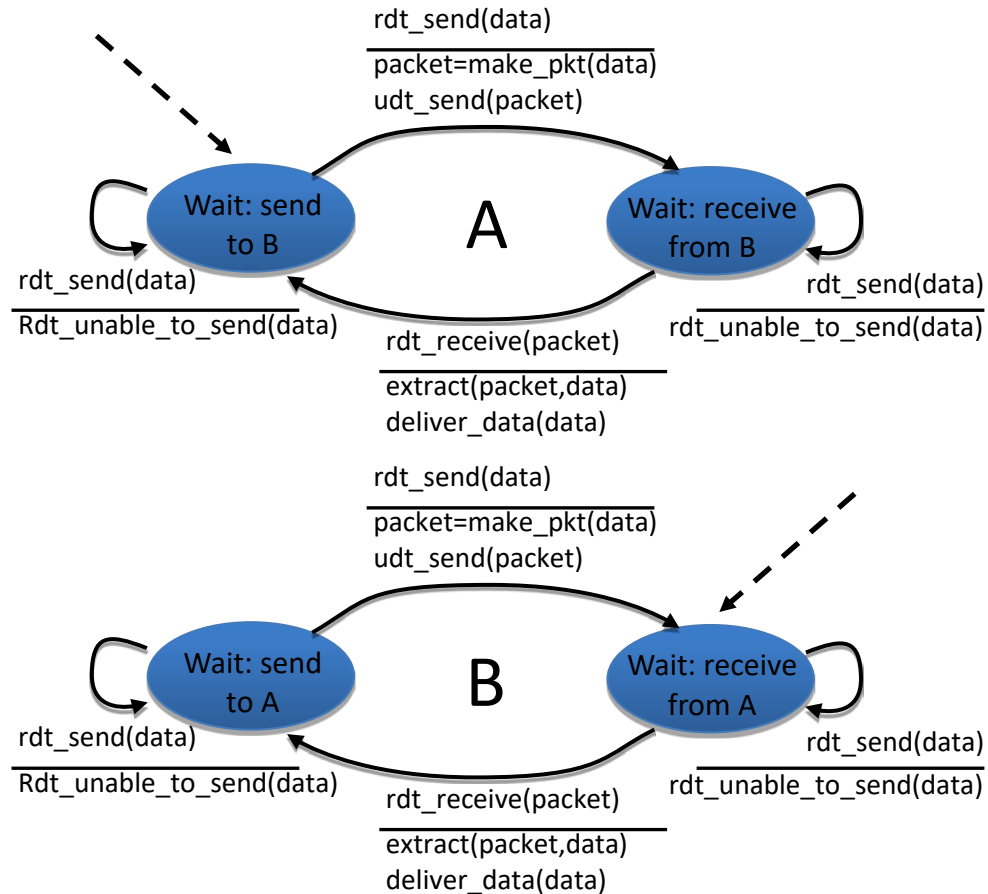

Problem 18

In our solution, the sender will wait until it receives an ACK for a pair of messages (seqnum and seqnum+1) before moving on to the next pair of messages. Data packets have a data field and carry a two-bit sequence number. That is, the valid sequence numbers are 0, 1, 2, and 3. (Note: you should think about why a 1-bit sequence number space of 0, 1 only would not work in the solution below.) ACK messages carry the sequence number of the data packet they are acknowledging.

The FSM for the sender and receiver are shown in Figure 2. Note that the sender state records whether (i) no ACKs have been received for the current pair, (ii) an ACK for seqnum (only) has been received, or an ACK for seqnum+1 (only) has been received. In this figure, we assume that the seqnum is initially 0, and that the sender has sent the first

two data messages (to get things going). A timeline trace for the sender and receiver recovering from a lost packet is shown below:

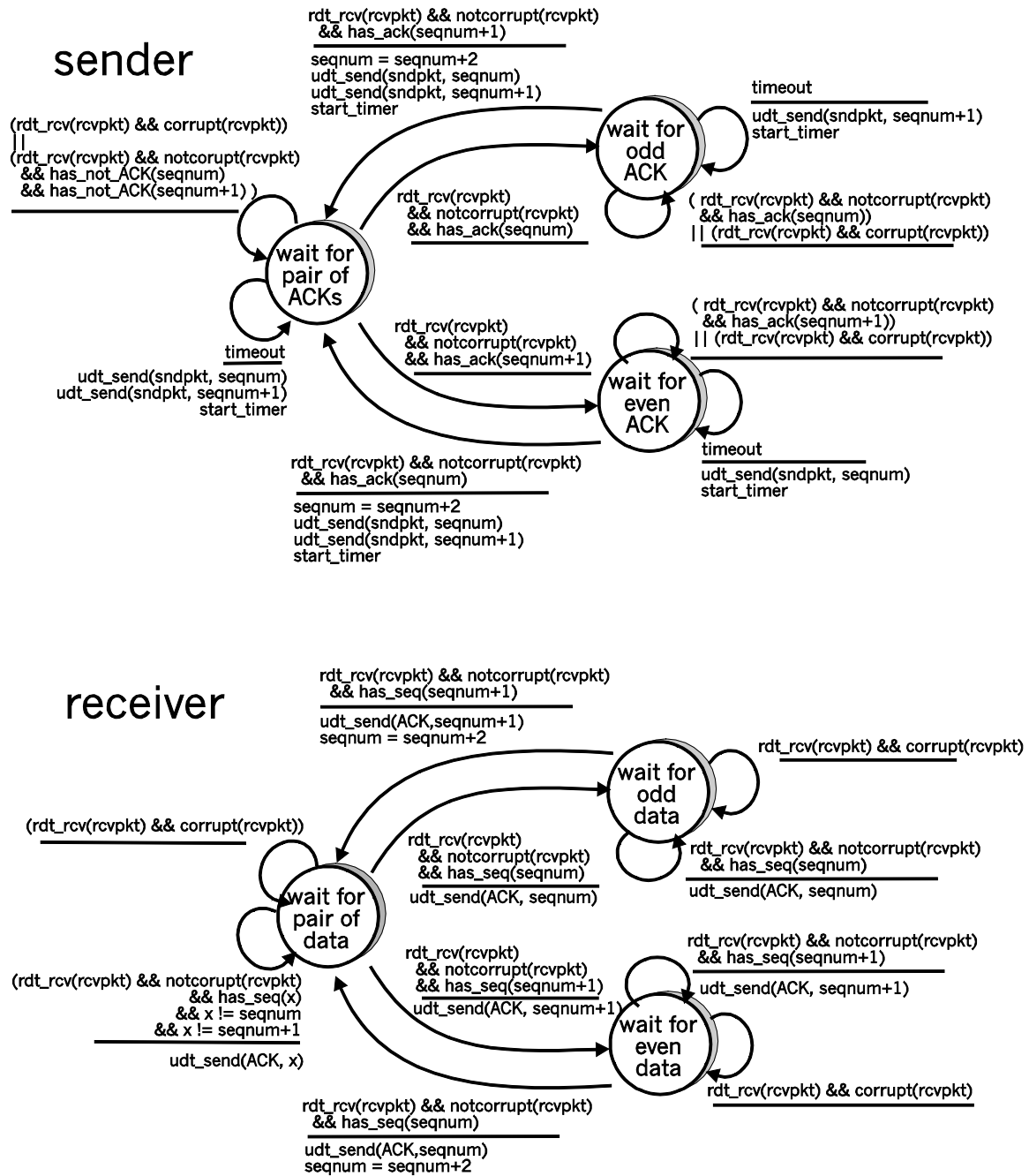

Figure 2: Sender and receiver for Problem (3.18)

Sender

Receiver

make pair (0,1)
send packet 0

Packet 0 drops
send packet 1

receive ACK 1
(timeout)
resend packet 0

receive ACK 0

receive packet 1
buffer packet 1
send ACK 1

receive packet 0
deliver pair (0,1)
send ACK 0

Problem 19

This problem is a variation on the simple stop and wait protocol (rdt3.0). Because the channel may lose messages and because the sender may resend a message that one of the receivers has already received (either because of a premature timeout or because the other receiver has yet to receive the data correctly), sequence numbers are needed. As in rdt3.0, a 0-bit sequence number will suffice here.

The sender and receiver FSM are shown in Figure 3. In this problem, the sender state indicates whether the sender has received an ACK from B (only), from C (only) or from neither C nor B. The receiver state indicates which sequence number the receiver is waiting for.

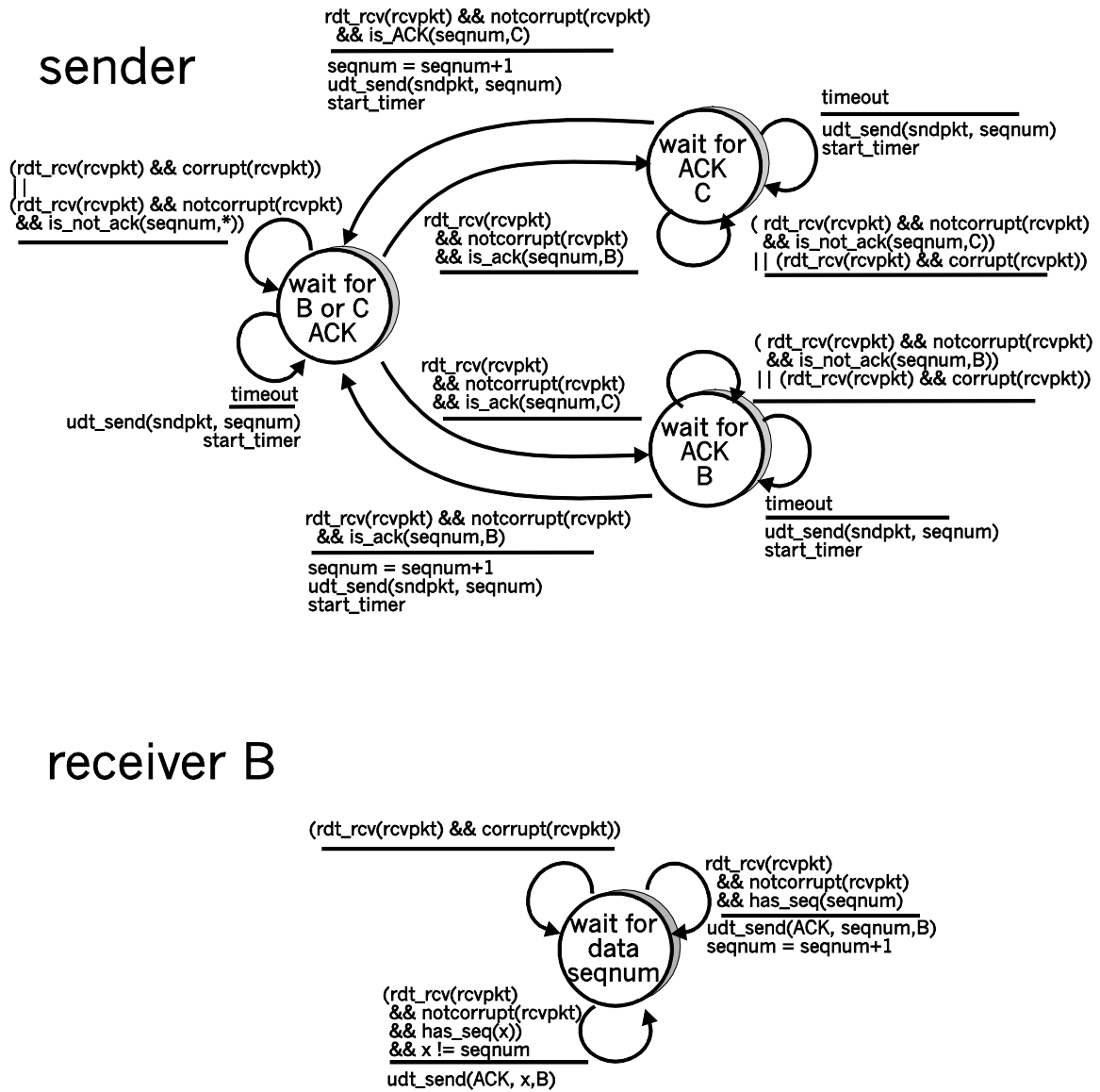

Figure 3. Sender and receiver for Problem 3.19(Problem 19)

Problem 20

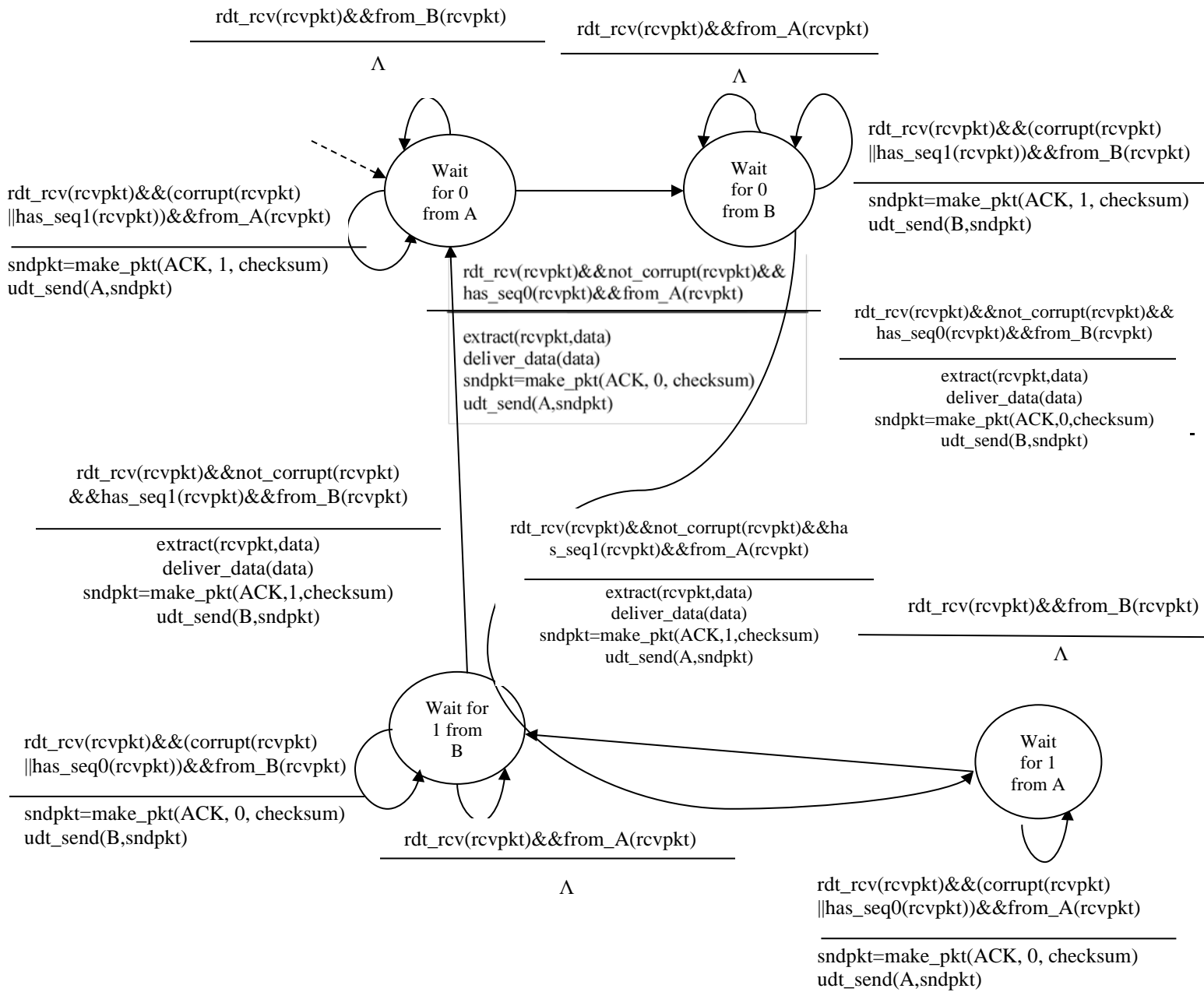

Figure 4: Receiver side FSM for 3.18

Sender

The sender side FSM is exactly same as given in Figure 3.15 in text

Problem 21

Because the A-to-B channel can lose request messages, A will need to timeout and retransmit its request messages (to be able to recover from loss). Because the channel delays are variable and unknown, it is possible that A will send duplicate requests (i.e., resend a request message that has already been received by B). To be able to detect duplicate request messages, the protocol will use sequence numbers. A 1-bit sequence number will suffice for a stop-and-wait type of request/response protocol.

A (the requestor) has 4 states:

- **“Wait for Request 0 from above.”** Here the requestor is waiting for a call from above to request a unit of data. When it receives a request from above, it sends a request message, R0, to B, starts a timer and makes a transition to the “Wait for D0” state. When in the “Wait for Request 0 from above” state, A ignores anything it receives from B.
- **“Wait for D0”.** Here the requestor is waiting for a D0 data message from B. A timer is always running in this state. If the timer expires, A sends another R0 message, restarts the timer and remains in this state. If a D0 message is received from B, A stops the time and transits to the “Wait for Request 1 from above” state. If A receives a D1 data message while in this state, it is ignored.
- **“Wait for Request 1 from above.”** Here the requestor is again waiting for a call from above to request a unit of data. When it receives a request from above, it sends a request message, R1, to B, starts a timer and makes a transition to the “Wait for D1” state. When in the “Wait for Request 1 from above” state, A ignores anything it receives from B.
- **“Wait for D1”.** Here the requestor is waiting for a D1 data message from B. A timer is always running in this state. If the timer expires, A sends another R1 message, restarts the timer and remains in this state. If a D1 message is received from B, A stops the timer and transits to the “Wait for Request 0 from above” state. If A receives a D0 data message while in this state, it is ignored.

The data supplier (B) has only two states:

- **“Send D0.”** In this state, B continues to respond to received R0 messages by sending D0, and then remaining in this state. If B receives a R1 message, then it knows its D0 message has been received correctly. It thus discards this D0 data (since it has been received at the other side) and then transits to the “Send D1” state, where it will use D1 to send the next requested piece of data.

- “Send D1.” In this state, B continues to respond to received R1 messages by sending D1, and then remaining in this state. If B receives a R1 message, then it knows its D1 message has been received correctly and thus transits to the “Send D1” state.

Problem 22

- a) Here we have a window size of $N=3$. Suppose the receiver has received packet $k-1$, and has ACKed that and all other preceding packets. If all of these ACK's have been received by sender, then sender's window is $[k, k+N-1]$. Suppose next that none of the ACKs have been received at the sender. In this second case, the sender's window contains $k-1$ and the N packets up to and including $k-1$. The sender's window is thus $[k-N, k-1]$. By these arguments, the sender's window is of size 3 and begins somewhere in the range $[k-N, k]$.
- b) If the receiver is waiting for packet k , then it has received (and ACKed) packet $k-1$ and the $N-1$ packets before that. If none of those N ACKs have been yet received by the sender, then ACK messages with values of $[k-N, k-1]$ may still be propagating back. Because the sender has sent packets $[k-N, k-1]$, it must be the case that the sender has already received an ACK for $k-N-1$. Once the receiver has sent an ACK for $k-N-1$ it will never send an ACK that is less than $k-N-1$. Thus the range of in-flight ACK values can range from $k-N-1$ to $k-1$.

Problem 23

In order to avoid the scenario of Figure 3.27, we want to avoid having the leading edge of the receiver's window (i.e., the one with the “highest” sequence number) wrap around in the sequence number space and overlap with the trailing edge (the one with the “lowest” sequence number in the sender's window). That is, the sequence number space must be large enough to fit the entire receiver window and the entire sender window without this overlap condition. So - we need to determine how large a range of sequence numbers can be covered at any given time by the receiver and sender windows.

Suppose that the lowest-sequence number that the receiver is waiting for is packet m . In this case, its window is $[m, m+w-1]$ and it has received (and ACKed) packet $m-1$ and the $w-1$ packets before that, where w is the size of the window. If none of those w ACKs have been yet received by the sender, then ACK messages with values of $[m-w, m-1]$ may still be propagating back. If no ACKs with these ACK numbers have been received by the sender, then the sender's window would be $[m-w, m-1]$.

Thus, the lower edge of the sender's window is $m-w$, and the leading edge of the receiver's window is $m+w-1$. In order for the leading edge of the receiver's window to not overlap with the trailing edge of the sender's window, the sequence number space must

thus be big enough to accommodate $2w$ sequence numbers. That is, the sequence number space must be at least twice as large as the window size, $k \geq 2w$.

Problem 24

- a) True. Suppose the sender has a window size of 3 and sends packets 1, 2, 3 at t_0 . At t_1 ($t_1 > t_0$) the receiver ACKS 1, 2, 3. At t_2 ($t_2 > t_1$) the sender times out and resends 1, 2, 3. At t_3 the receiver receives the duplicates and re-acknowledges 1, 2, 3. At t_4 the sender receives the ACKs that the receiver sent at t_1 and advances its window to 4, 5, 6. At t_5 the sender receives the ACKs 1, 2, 3 the receiver sent at t_2 . These ACKs are outside its window.
- b) True. By essentially the same scenario as in (a).
- c) True.
- d) True. Note that with a window size of 1, SR, GBN, and the alternating bit protocol are functionally equivalent. The window size of 1 precludes the possibility of out-of-order packets (within the window). A cumulative ACK is just an ordinary ACK in this situation, since it can only refer to the single packet within the window.

Problem 25

- a) Consider sending an application message over a transport protocol. With TCP, the application writes data to the connection send buffer and TCP will grab bytes without necessarily putting a single message in the TCP segment; TCP may put more or less than a single message in a segment. UDP, on the other hand, encapsulates in a segment whatever the application gives it; so that, if the application gives UDP an application message, this message will be the payload of the UDP segment. Thus, with UDP, an application has more control of what data is sent in a segment.
- b) With TCP, due to flow control and congestion control, there may be significant delay from the time when an application writes data to its send buffer until when the data is given to the network layer. UDP does not have delays due to flow control and congestion control.

Problem 26

There are $2^{32} = 4,294,967,296$ possible sequence numbers.

- a) The sequence number does not increment by one with each segment. Rather, it increments by the number of bytes of data sent. So the size of the MSS is irrelevant -- the maximum size file that can be sent from A to B is simply the number of bytes representable by $2^{32} \approx 4.19$ Gbytes.

$$\left\lceil \frac{2^{32}}{536} \right\rceil = 8,012,999$$

- b) The number of segments is $\left\lceil \frac{2^{32}}{536} \right\rceil = 8,012,999$. 66 bytes of header get added to each segment giving a total of 528,857,934 bytes of header. The total number of bytes transmitted is $2^{32} + 528,857,934 = 4.824 \times 10^9$ bytes.

Thus it would take 249 seconds to transmit the file over a 155-Mbps link.

Problem 27

- In the second segment from Host A to B, the sequence number is 207, source port number is 302 and destination port number is 80.
- If the first segment arrives before the second, in the acknowledgement of the first arriving segment, the acknowledgement number is 207, the source port number is 80 and the destination port number is 302.
- If the second segment arrives before the first segment, in the acknowledgement of the first arriving segment, the acknowledgement number is 127, indicating that it is still waiting for bytes 127 and onwards.
-

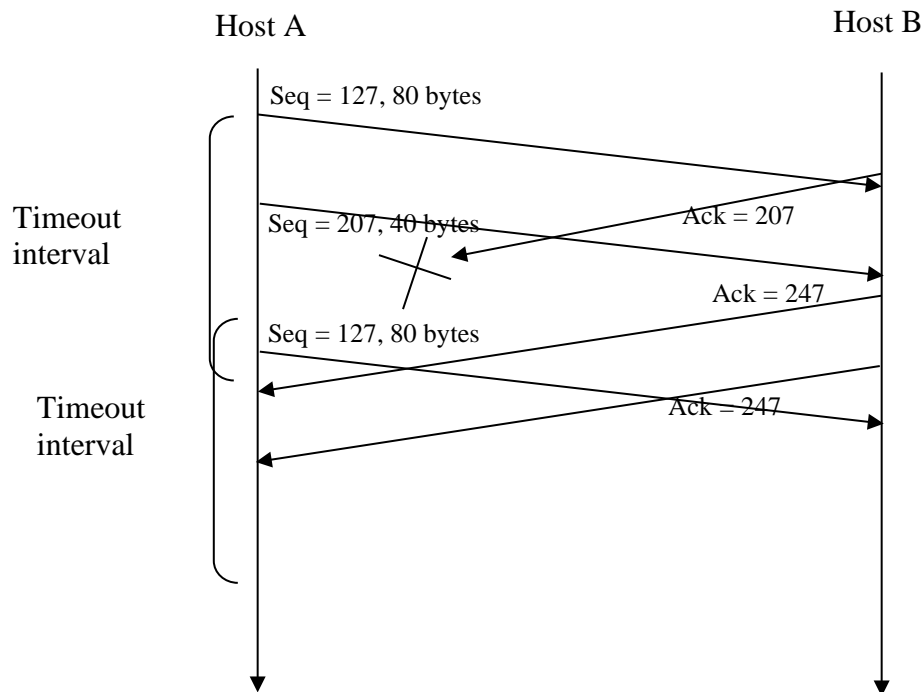

Problem 28

Since the link capacity is only 100 Mbps, so host A's sending rate can be at most 100Mbps. Still, host A sends data into the receive buffer faster than Host B can remove data from the buffer. The receive buffer fills up at a rate of roughly 40Mbps. When the buffer is full, Host B signals to Host A to stop sending data by setting RcvWindow = 0. Host A then stops sending until it receives a TCP segment with RcvWindow > 0. Host A will thus repeatedly stop and start sending as a function of the RcvWindow values it

receives from Host B. On average, the long-term rate at which Host A sends data to Host B as part of this connection is no more than 60Mbps.

Problem 29

- a) The server uses special initial sequence number (that is obtained from the hash of source and destination IPs and ports) in order to defend itself against SYN FLOOD attack.
- b) No, the attacker cannot create half-open or fully open connections by simply sending and ACK packet to the target. Half-open connections are not possible since a server using SYN cookies does not maintain connection variables and buffers for any connection before full connections are established. For establishing fully open connections, an attacker should know the special initial sequence number corresponding to the (spoofed) source IP address from the attacker. This sequence number requires the "secret" number that each server uses. Since the attacker does not know this secret number, she cannot guess the initial sequence number.
- c) No, the sever can simply add in a time stamp in computing those initial sequence numbers and choose a time to live value for those sequence numbers, and discard expired initial sequence numbers even if the attacker replay them.

Problem 30

- a) If timeout values are fixed, then the senders may timeout prematurely. Thus, some packets are re-transmitted even they are not lost.
- b) If timeout values are estimated (like what TCP does), then increasing the buffer size certainly helps to increase the throughput of that router. But there might be one potential problem. Queuing delay might be very large, similar to what is shown in Scenario 1.

Problem 31

$$\text{DevRTT} = (1 - \beta) * \text{DevRTT} + \beta * | \text{SampleRTT} - \text{EstimatedRTT} |$$

$$\text{EstimatedRTT} = (1 - \alpha) * \text{EstimatedRTT} + \alpha * \text{SampleRTT}$$

$$\text{TimeoutInterval} = \text{EstimatedRTT} + 4 * \text{DevRTT}$$

After obtaining first SampleRTT 106ms:

$$\text{DevRTT} = 0.75 * 5 + 0.25 * | 106 - 100 | = 5.25 \text{ms}$$

$$\text{EstimatedRTT} = 0.875 * 100 + 0.125 * 106 = 100.75 \text{ms}$$

$$\text{TimeoutInterval} = 100.75 + 4 * 5.25 = 121.75 \text{ms}$$

After obtaining 120ms:

$$\text{DevRTT} = 0.75 * 5.25 + 0.25 * | 120 - 100.75 | = 8.75 \text{ms}$$

$$\text{EstimatedRTT} = 0.875 * 100.75 + 0.125 * 120 = 103.16 \text{ms}$$

$$\text{TimeoutInterval} = 103.16 + 4 * 8.75 = 138.16 \text{ ms}$$

After obtaining 140ms:

$$\text{DevRTT} = 0.75 * 8.75 + 0.25 * |140 - 103.16| = 15.77 \text{ ms}$$

$$\text{EstimatedRTT} = 0.875 * 103.16 + 0.125 * 140 = 107.76 \text{ ms}$$

$$\text{TimeoutInterval} = 107.76 + 4 * 15.77 = 170.84 \text{ ms}$$

After obtaining 90ms:

$$\text{DevRTT} = 0.75 * 15.77 + 0.25 * |90 - 107.76| = 16.27 \text{ ms}$$

$$\text{EstimatedRTT} = 0.875 * 107.76 + 0.125 * 90 = 105.54 \text{ ms}$$

$$\text{TimeoutInterval} = 105.54 + 4 * 16.27 = 170.62 \text{ ms}$$

After obtaining 115ms:

$$\text{DevRTT} = 0.75 * 16.27 + 0.25 * |115 - 105.54| = 14.57 \text{ ms}$$

$$\text{EstimatedRTT} = 0.875 * 105.54 + 0.125 * 115 = 106.72 \text{ ms}$$

$$\text{TimeoutInterval} = 106.72 + 4 * 14.57 = 165 \text{ ms}$$

Problem 32

a)

Denote $EstimatedRTT^{(n)}$ for the estimate after the n th sample.

$$\begin{aligned} EstimatedRTT^{(4)} &= xSampleRTT_1 + \\ &\quad (1-x)[xSampleRTT_2 + \\ &\quad (1-x)[xSampleRTT_3 + (1-x)SampleRTT_4]] \\ &= xSampleRTT_1 + (1-x)xSampleRTT_2 \\ &\quad + (1-x)^2 xSampleRTT_3 + (1-x)^3 SampleRTT_4 \end{aligned}$$

b)

$$\begin{aligned} EstimatedRTT^{(n)} &= x \sum_{j=1}^{n-1} (1-x)^{j-1} SampleRTT_j \\ &\quad + (1-x)^{n-1} SampleRTT_n \end{aligned}$$

c)

$$\begin{aligned} EstimatedRTT^{(\infty)} &= \frac{x}{1-x} \sum_{j=1}^{\infty} (1-x)^j SampleRTT_j \\ &= \frac{1}{9} \sum_{j=1}^{\infty} .9^j SampleRTT_j \end{aligned}$$

The weight given to past samples decays exponentially.

Problem 33

Let's look at what could be wrong if TCP measures `SampleRTT` for a retransmitted segment. Suppose the source sends packet P1, the timer for P1 expires, and the source then sends P2, a new copy of the same packet. Further suppose the source measures `SampleRTT` for P2 (the retransmitted packet). Finally suppose that shortly after transmitting P2 an acknowledgment for P1 arrives. The source will mistakenly take this acknowledgment as an acknowledgment for P2 and calculate an incorrect value of `SampleRTT`.

Let's look at what could be wrong if TCP measures `SampleRTT` for a retransmitted segment. Suppose the source sends packet P1, the timer for P1 expires, and the source then sends P2, a new copy of the same packet. Further suppose the source measures `SampleRTT` for P2 (the retransmitted packet). Finally suppose that shortly after transmitting P2 an acknowledgment for P1 arrives. The source will mistakenly take this acknowledgment as an acknowledgment for P2 and calculate an incorrect value of `SampleRTT`.

Problem 34

At any given time t , `SendBase - 1` is the sequence number of the last byte that the sender knows has been received correctly, and in order, at the receiver. The actually last byte received (correctly and in order) at the receiver at time t may be greater if there are acknowledgements in the pipe. Thus

$$\text{SendBase} - 1 \leq \text{LastByteRcvd}$$

Problem 35

When, at time t , the sender receives an acknowledgement with value y , the sender knows for sure that the receiver has received everything up through $y-1$. The actual last byte received (correctly and in order) at the receiver at time t may be greater if $y \leq \text{SendBase}$ or if there are other acknowledgements in the pipe. Thus

$$y - 1 \leq \text{LastByteRcvd}$$

Problem 36

Suppose packets n , $n+1$, and $n+2$ are sent, and that packet n is received and ACKed. If packets $n+1$ and $n+2$ are reordered along the end-to-end-path (i.e., are received in the order $n+2$, $n+1$) then the receipt of packet $n+2$ will generate a duplicate ack for n and would trigger a retransmission under a policy of waiting only for second duplicate ACK for retransmission. By waiting for a triple duplicate ACK, it must be the case that *two*

packets after packet n are correctly received, while $n+1$ was not received. The designers of the triple duplicate ACK scheme probably felt that waiting for two packets (rather than 1) was the right tradeoff between triggering a quick retransmission when needed, but not retransmitting prematurely in the face of packet reordering.

Problem 37

a) GoBackN:

A sends 9 segments in total. They are initially sent segments 1, 2, 3, 4, 5 and later re-sent segments 2, 3, 4, and 5.

B sends 8 ACKs. They are 4 ACKS with sequence number 1, and 4 ACKS with sequence numbers 2, 3, 4, and 5.

Selective Repeat:

A sends 6 segments in total. They are initially sent segments 1, 2, 3, 4, 5 and later re-sent segments 2.

B sends 5 ACKs. They are 4 ACKS with sequence number 1, 3, 4, 5. And there is one ACK with sequence number 2.

TCP:

A sends 6 segments in total. They are initially sent segments 1, 2, 3, 4, 5 and later re-sent segments 2.

B sends 5 ACKs. They are 4 ACKS with sequence number 2. There is one ACK with sequence numbers 6. Note that TCP always send an ACK with expected sequence number.

b) TCP. This is because TCP uses fast retransmit without waiting until time out.

Problem 38

Yes, the sending rate is always roughly $cwnd/RTT$.

Problem 39

If the arrival rate increases beyond $R/2$ in Figure 3.46(b), then the total arrival rate to the queue exceeds the queue's capacity, resulting in increasing loss as the arrival rate increases. When the arrival rate equals $R/2$, 1 out of every three packets that leaves the queue is a retransmission. With increased loss, even a larger fraction of the packets leaving the queue will be retransmissions. Given that the maximum departure rate from the queue for one of the sessions is $R/2$, and given that a third or more will be transmissions as the arrival rate increases, the throughput of successfully deliver data can not increase beyond λ_{out} . Following similar reasoning, if half of the packets leaving the queue are retransmissions, and the maximum rate of output packets per session is $R/2$, then the maximum value of λ_{out} is $(R/2)/2$ or $R/4$.

Problem 40

- a) TCP slowstart is operating in the intervals [1,6] and [23,26]
- b) TCP congestion avoidance is operating in the intervals [6,16] and [17,22]
- c) After the 16th transmission round, packet loss is recognized by a triple duplicate ACK. If there was a timeout, the congestion window size would have dropped to 1.
- d) After the 22nd transmission round, segment loss is detected due to timeout, and hence the congestion window size is set to 1.
- e) The threshold is initially 32, since it is at this window size that slow start stops and congestion avoidance begins.
- f) The threshold is set to half the value of the congestion window when packet loss is detected. When loss is detected during transmission round 16, the congestion window size is 42. Hence the threshold is 21 during the 18th transmission round.
- g) The threshold is set to half the value of the congestion window when packet loss is detected. When loss is detected during transmission round 22, the congestion window size is 29. Hence the threshold is 14 (taking lower floor of 14.5) during the 24th transmission round.
- h) During the 1st transmission round, packet 1 is sent; packet 2-3 are sent in the 2nd transmission round; packets 4-7 are sent in the 3rd transmission round; packets 8-15 are sent in the 4th transmission round; packets 16-31 are sent in the 5th transmission round; packets 32-63 are sent in the 6th transmission round; packets 64 – 96 are sent in the 7th transmission round. Thus packet 70 is sent in the 7th transmission round.
- i) The threshold will be set to half the current value of the congestion window (8) when the loss occurred and congestion window will be set to the new threshold value + 3 MSS . Thus the new values of the threshold and window will be 4 and 7 respectively.
- j) threshold is 21, and congestion window size is 1.
- k) round 17, 1 packet; round 18, 2 packets; round 19, 4 packets; round 20, 8 packets; round 21, 16 packets; round 22, 21 packets. So, the total number is 52.

Problem 41

Refer to Figure 5. In Figure 5(a), the ratio of the linear decrease on loss between connection 1 and connection 2 is the same - as ratio of the linear increases: unity. In this case, the throughputs never move off of the AB line segment. In Figure 5(b), the ratio of the linear decrease on loss between connection 1 and connection 2 is 2:1. That is, whenever there is a loss, connection 1 decreases its window by twice the amount of connection 2. We see that eventually, after enough losses, and subsequent increases, that connection 1's throughput will go to 0, and the full link bandwidth will be allocated to connection 2.

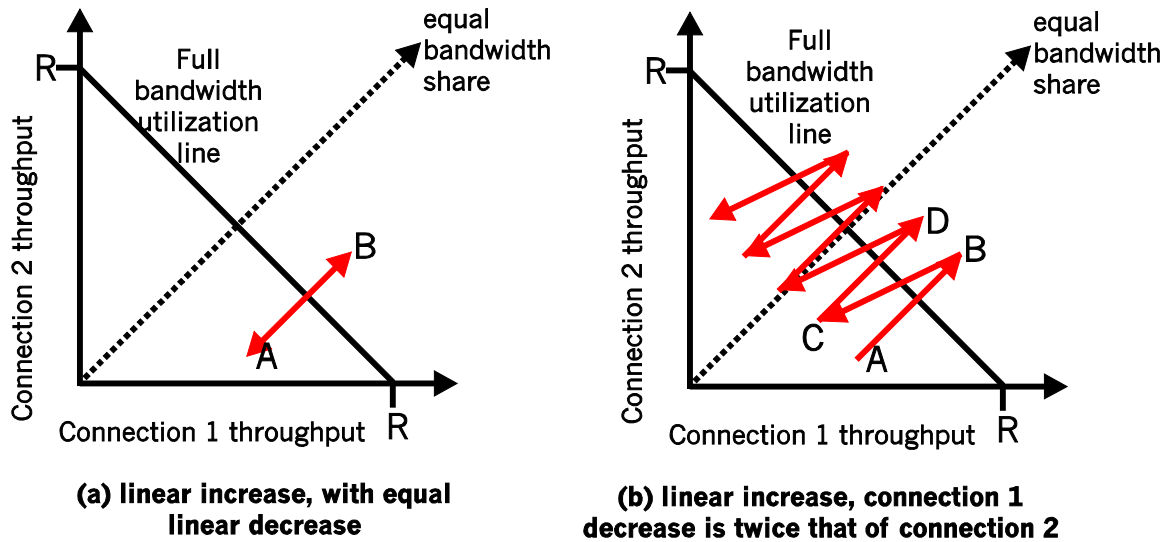

Figure 5: Lack of TCP convergence with linear increase, linear decrease

Problem 42

If TCP were a stop-and-wait protocol, then the doubling of the time out interval would suffice as a congestion control mechanism. However, TCP uses pipelining (and is therefore not a stop-and-wait protocol), which allows the sender to have multiple outstanding unacknowledged segments. The doubling of the timeout interval does not prevent a TCP sender from sending a large number of first-time-transmitted packets into the network, even when the end-to-end path is highly congested. Therefore a congestion-control mechanism is needed to stem the flow of “data received from the application above” when there are signs of network congestion.

Problem 43

In this problem, there is no danger in overflowing the receiver since the receiver’s receive buffer can hold the entire file. Also, because there is no loss and acknowledgements are returned before timers expire, TCP congestion control does not throttle the sender. However, the process in host A will not continuously pass data to the socket because the send buffer will quickly fill up. Once the send buffer becomes full, the process will pass data at an average rate or $R \ll S$.

Problem 44

a) It takes 1 RTT to increase CongWin to 7 MSS; 2 RTTs to increase to 8 MSS; 3 RTTs to increase to 9 MSS; 4 RTTs to increase to 10 MSS; 5 RTTs to increase to 11 MSS; 6 RTTs to increase to 12 MSS.

b) In the first RTT 6 MSS was sent; in the second RTT 7 MSS was sent; in the third RTT 8 MSS was sent; in the fourth RTT 9 MSS was sent; in the fifth RTT, 10 MSS was sent; and in the sixth RTT, 11 MSS was sent. Thus, up to time 6 RTT,

$6+7+8+9+10+11 = 51$ MSS were sent. Thus, we can say that the average throughput up to time 6 RTT was $(51 \text{ MSS})/(6 \text{ RTT}) = 8.5 \text{ MSS/RTT}$.

Problem 45

- a) The loss rate, L , is the ratio of the number of packets lost over the number of packets sent. In a cycle, 1 packet is lost. The number of packets sent in a cycle is

$$\begin{aligned} \frac{W}{2} + \left(\frac{W}{2} + 1\right) + \dots + W &= \sum_{n=0}^{W/2} \left(\frac{W}{2} + n\right) \\ &= \left(\frac{W}{2} + 1\right) \frac{W}{2} + \sum_{n=0}^{W/2} n \\ &= \left(\frac{W}{2} + 1\right) \frac{W}{2} + \frac{W/2(W/2 + 1)}{2} \\ &= \frac{W^2}{4} + \frac{W}{2} + \frac{W^2}{8} + \frac{W}{4} \\ &= \frac{3}{8}W^2 + \frac{3}{4}W \end{aligned}$$

Thus the loss rate is

$$L = \frac{1}{\frac{3}{8}W^2 + \frac{3}{4}W}$$

- b) For W large, $\frac{3}{8}W^2 \gg \frac{3}{4}W$. Thus $L \approx 8/3W^2$ or $W \approx \sqrt{\frac{8}{3L}}$. From the text, we therefore have

$$\begin{aligned} \text{average throughput} &= \frac{3}{4} \sqrt{\frac{8}{3L}} \cdot \frac{MSS}{RTT} \\ &= \frac{1.22 \cdot MSS}{RTT \cdot \sqrt{L}} \end{aligned}$$

Problem 46

- a) Let W denote the max window size measured in segments. Then, $W \cdot MSS/RTT = 10 \text{ Mbps}$, as packets will be dropped if the maximum sending rate exceeds link capacity. Thus, we have $W \cdot 1500 \cdot 8 / 0.15 = 10 \cdot 10^6$, then W is about 125 segments.

- b) As congestion window size varies from $W/2$ to W , then the average window size is $0.75W=94$ (ceiling of 93.75) segments. Average throughput is $94*1500*8/0.15=7.52\text{Mbps}$.
- c) When there is a packet loss, W becomes $W/2$, i.e., $125/2=62$.
 $(125 - 62) * 0.15 = 9.45$ seconds, as the number of RTTs (that this TCP connections needs in order to increase its window size from 62 to 125) is 63. Recall the window size increases by one in each RTT.

Problem 47

Let W denote max window size. Let S denote the buffer size. For simplicity, suppose TCP sender sends data packets in a round by round fashion, with each round corresponding to a RTT. If the window size reaches W , then a loss occurs. Then the sender will cut its congestion window size by half, and waits for the ACKs for $W/2$ outstanding packets before it starts sending data segments again. In order to make sure the link always busy sending data, we need to let the link busy sending data in the period $W/(2*C)$ (this is the time interval where the sender is waiting for the ACKs for the $W/2$ outstanding packets). Thus, S/C must be no less than $W/(2*C)$, that is, $S \geq W/2$.

Let T_p denote the one-way propagation delay between the sender and the receiver. When the window size reaches the minimum $W/2$ and the buffer is empty, we need to make sure the link is also busy sending data. Thus, we must have $W/2/(2T_p) \geq C$, thus, $W/2 \geq C*2T_p$.

Thus, $S \geq C*2T_p$.

Problem 48

- a) Let W denote the max window size. Then, $W*MSS/RTT = 10\text{Gbps}$, as packets will be dropped if maximum sending rate reaches link capacity. Thus, we have $W*1500*8/0.15=10*10^9$, then $W= 125000$ segments.
- b) As congestion window size varies from $W/2$ to W , then the average window size is $0.75W=93750$ segments. Average throughput is $93750*1500*8/0.1=7.5\text{Gbps}$.
- c) $93750/2 * 0.15 / 60 = 117$ minutes. In order to speed up the window increase process, we can increase the window size by a much larger value, instead of increasing window size only by one in each RTT. Some protocols are proposed to solve this problem, such as ScalableTCP or HighSpeed TCP.

Problem 49

As TCP's average throughput B is given by $B = \frac{1.22 \cdot MSS}{RTT \cdot \sqrt{L}}$, so we know that,

$$L = (1.22 * MSS / (B * RTT))^2$$

Since between two consecutive packet losses, there are $1/L$ packets sent by the TCP sender, thus, $T = (1/L) * MSS / B$. Thus, we find that $T = B * RTT^2 / (1.22^2 * MSS)$, that is, T is a function of B .

Problem 50

- a) The key difference between C1 and C2 is that C1's RTT is only half of that of C2. Thus C1 adjusts its window size after 50 msec, but C2 adjusts its window size after 100 msec. Assume that whenever a loss event happens, C1 receives it after 50msec and C2 receives it after 100msec. We further have the following simplified model of TCP. After each RTT, a connection determines if it should increase window size or not. For C1, we compute the average total sending rate in the link in the previous 50 msec. If that rate exceeds the link capacity, then we assume that C1 detects loss and reduces its window size. But for C2, we compute the average total sending rate in the link in the previous 100msec. If that rate exceeds the link capacity, then we assume that C2 detects loss and reduces its window size. Note that it is possible that the average sending rate in last 50msec is higher than the link capacity, but the average sending rate in last 100msec is smaller than or equal to the link capacity, then in this case, we assume that C1 will experience loss event but C2 will not.

The following table describes the evolution of window sizes and sending rates based on the above assumptions.

	C1		C2	
Time (msec)	Window Size (num. of segments sent in next 50msec)	Average data sending rate (segments per second, =Window/0.05)	Window Size(num. of segments sent in next 100msec)	Average data sending rate (segments per second, =Window/0.1)
0	10	200 (in [0-50]msec)	10	100 (in [0-50]msec)
50	5 (decreases window size as the avg. total sending rate to the link in last 50msec is $300 = \frac{200+100}{0.05}$)	100 (in [50-100]msec)		100 (in [50-100]msec)
100	2 (decreases window size as the avg. total sending rate to the link in last 50msec is $200 = \frac{100+100}{0.05}$)	40	5 (decreases window size as the avg. total sending rate to the link in last 100msec is $250 = \frac{(200+100)}{0.1}$)	50

			$(100+100)/2$	
150	1 (decreases window size as the avg. total sending rate to the link in last 50msec is $90 = (40+50)$)	20		50
200	1 (no further decrease, as window size is already 1)	20	2 (decreases window size as the avg. total sending rate to the link in last 100msec is $80 = (40+20)/2 + (50+50)/2$)	20
250	1 (no further decrease, as window size is already 1)	20		20
300	1 (no further decrease, as window size is already 1)	20	1 (decreases window size as the avg. total sending rate to the link in last 100msec is $40 = (20+20)/2 + (20+20)/2$)	10
350	2	40		10
400	1	20	1	10
450	2	40		10
500	1 (decreases window size as the avg. total sending rate to the	20	1	10

	link in last 50msec is $50 = (40+10)$			
550	2	40		10
600	1	20	1	10
650	2	40		10
700	1	20	1	10
750	2	40		10
800	1	20	1	10
850	2	40		10
900	1	20	1	10
950	2	40		10
1000	1	20	1	10

Based on the above table, we find that after 1000 msec, C1's and C2's window sizes are 1 segment each.

- b) No. In the long run, C1's bandwidth share is roughly twice as that of C2's, because C1 has shorter RTT, only half of that of C2, so C1 can adjust its window size twice as fast as C2. If we look at the above table, we can see a cycle every 200msec, e.g. from 850msec to 1000msec, inclusive. Within a cycle, the sending rate of C1 is $(40+20+40+20) = 120$, which is thrice as large as the sending of C2 given by $(10+10+10+10) = 40$.

Problem 51

- a) Similarly as in last problem, we can compute their window sizes over time in the following table. Both C1 and C2 have the same window size 2 after 2200msec.

Time (msec)	C1		C2	
	Window Size (num. of segments sent in next 100msec)	Data sending speed (segments per second, $=\text{Window}/0.1$)	Window Size (num. of segments sent in next 100msec)	Data sending speed (segments per second, $=\text{Window}/0.1$)
0	15	150 (in [0-100]msec)	10	100 (in [0-100]msec)
100	7	70	5	50
200	3	30	2	20
300	1	10	1	10
400	2	20	2	20
500	1	10	1	10
600	2	20	2	20
700	1	10	1	10
800	2	20	2	20
900	1	10	1	10
1000	2	20	2	20

1100	1	10	1	10
1200	2	20	2	20
1300	1	10	1	10
1400	2	20	2	20
1500	1	10	1	10
1600	2	20	2	20
1700	1	10	1	10
1800	2	20	2	20
1900	1	10	1	10
2000	2	20	2	20
2100	1	10	1	10
2200	2	20	2	20

- b) Yes, this is due to the AIMD algorithm of TCP and that both connections have the same RTT.
- c) Yes, this can be seen clearly from the above table. Their max window size is 2.
- d) No, this synchronization won't help to improve link utilization, as these two connections act as a single connection oscillating between min and max window size. Thus, the link is not fully utilized (recall we assume this link has no buffer). One possible way to break the synchronization is to add a finite buffer to the link and randomly drop packets in the buffer before buffer overflow. This will cause different connections cut their window sizes at different times. There are many AQM (Active Queue Management) techniques to do that, such as RED (Random Early Detect), PI (Proportional and Integral AQM), AVQ (Adaptive Virtual Queue), and REM (Random Exponential Marking), etc.

Problem 52

Note that W represents the maximum window size.

First we can find the total number of segments sent out during the interval when TCP changes its window size from $W/2$ up to and include W . This is given by:

$$S = W/2 + (W/2)*(1+\alpha) + (W/2)*(1+\alpha)^2 + (W/2)*(1+\alpha)^3 + \dots + (W/2)*(1+\alpha)^k$$

We find $k = \log_{(1+\alpha)} 2$, then $S = W*(2\alpha+1)/(2\alpha)$.

Loss rate L is given by:

$$L = 1/S = (2\alpha) / (W*(2\alpha+1)).$$

The time that TCP takes to increase its window size from $W/2$ to W is given by:

$$k*RTT = (\log_{(1+\alpha)} 2) * RTT,$$

which is clearly independent of TCP's average throughput.

Note, TCP's average throughput is given by:

$$B = MSS * S / ((k+1)*RTT) = MSS / (L*(k+1)*RTT).$$

Note that this is different from TCP which has average throughput: $B = \frac{1.22 \cdot MSS}{RTT \cdot \sqrt{L}}$, where the square root of L appears in the denominator.

Problem 53

Let's assume 1500-byte packets and a 100 ms round-trip time. From the TCP throughput equation $B = \frac{1.22 \cdot MSS}{RTT \cdot \sqrt{L}}$, we have

10 Gbps = $1.22 * (1500 * 8 \text{ bits}) / (.1 \text{ sec} * \text{sqrt}(L))$, or

$\text{sqrt}(L) = 14640 \text{ bits} / (10^9 \text{ bits}) = 0.00001464$, or

$L = 2.14 * 10^{(-10)}$

Problem 54

An advantage of using the earlier values of `cwnd` and `ssthresh` at t_2 is that TCP would not have to go through slow start and congestion avoidance to ramp up to the throughput value obtained at t_1 . A disadvantage of using these values is that they may be no longer accurate. In particular, if the path has become more congested between t_1 and t_2 , the sender will send a large window's worth of segments into an already (more) congested path.

Problem 55

- a) The server will send its response to Y.
- b) The server can be certain that the client is indeed at Y. If it were at some other address spoofing Y, the SYNACK would have been sent to the address Y, and the TCP in that host would not send the TCP ACK segment back. Even if the attacker were to send an appropriately timed TCP ACK segment, it would not know the correct server sequence number (since the server uses random initial sequence numbers.)

Problem 56

- a) Referring to the figure below, we see that the total delay is

$$RTT + RTT + S/R + RTT + S/R + RTT + 12S/R = 4RTT + 14 S/R$$

b) Similarly, the delay in this case is:

$$RTT+RTT + S/R + RTT + S/R + RTT + S/R + RTT + 8S/R = 5RTT +11 S/R$$

c) Similarly, the delay in this case is:

$$RTT + RTT + S/R + RTT + 14 S/R = 3 RTT + 15 S/R$$

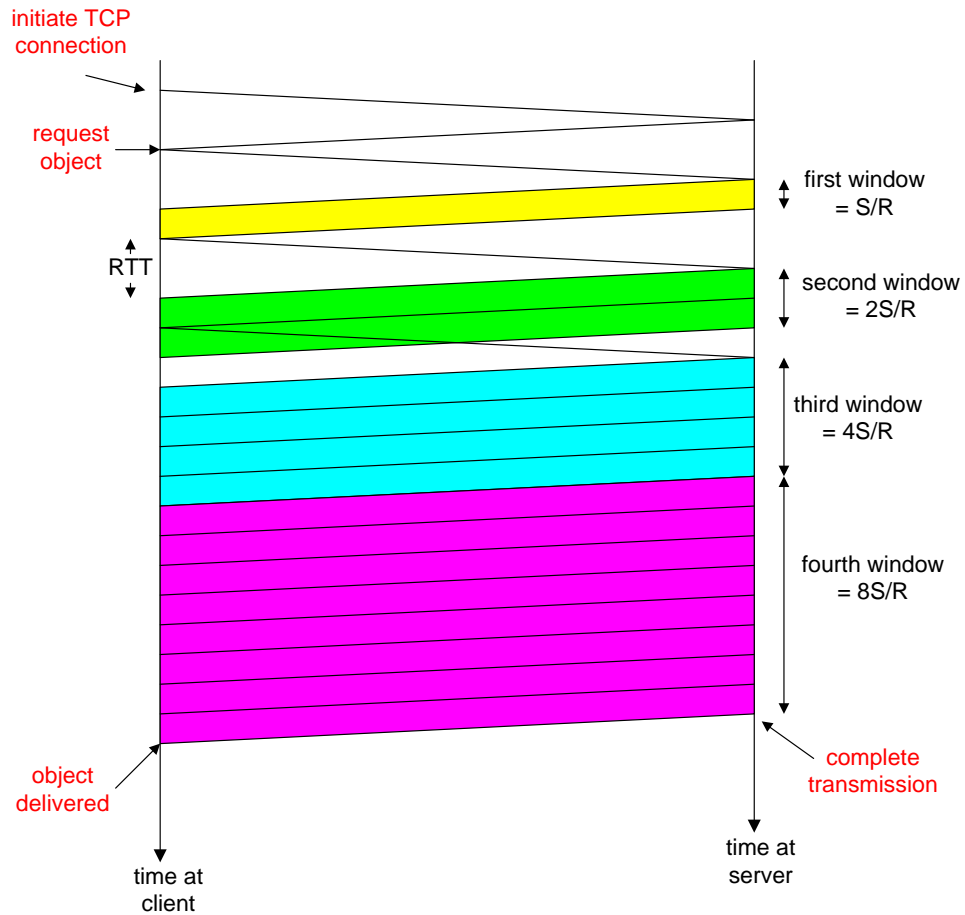

Chapter 4 Review Questions

1. A network-layer packet is a datagram. A router forwards a packet based on the packet's IP (layer 3) address. A link-layer switch forwards a packet based on the packet's MAC (layer 2) address.
2. The main function of the data plane is packet forwarding, which is to forward datagrams from their input links to their output links. For example, the data plane's input ports perform physical layer function of terminating an incoming physical link at a router, perform link-layer function to interoperate with the link layer at the other side of the incoming link, and perform lookup function at the input ports.

The main function of the control plane is routing, which is to determine the paths a packet takes from its source to its destination. A control plane is responsible for executing routing protocols, responding to attached links that go up or down, communicating with remote controllers, and performing management functions.

3. The key differences between routing and forwarding is that forwarding is a router's local action of transferring packets from its input interfaces to its output interfaces, and forwarding takes place at very short timescales (typically a few nanoseconds), and thus is typically implemented in hardware. Routing refers to the network-wide process that determines the end-to-end paths that packets take from sources to destinations. Routing takes place on much longer timescales (typically seconds), and is often implemented in software.
4. The role of the forwarding table within a router is to hold entries to determine the outgoing link interface to which an arriving packet will be forwarded via switching fabric.
5. The service model of the Internet's network layer is best-effort service. With this service model, there is no guarantee that packets will be received in the order in which they were sent, no guarantee of their eventual delivery, no guarantee on the end-to-end delay, and no minimal bandwidth guarantee.
6. Input port, switching fabric, and output ports are implemented in hardware, because their datagram-processing functionality is far too fast for software implementation. A routing processor inside a traditional router uses software for executing routing protocols, maintaining routing tables and attached link state information, and computing the forwarding table of a router. In addition, a routing processor in a SDN router also relies on software for communication with a remote controller in order to receive forwarding table entries and install them in the router's input ports.

Data plane is usually implemented in hardware due to the requirement of fast processing, e.g., at nanosecond time scale. Control plane is usually implemented in software and operates at the millisecond or second timescale, for example, for

executing routing protocols, responding to attached links that go up or down, communicating with remote controllers, and performing management functions.

7. With the shadow copy, the forwarding lookup is made locally, at each input port, without invoking the centralized routing processor. Such a decentralized approach avoids creating a lookup processing bottleneck at a single point within the router.
8. Destination-based forwarding means that a datagram arriving at a router will be forwarded to an output interface based on only the final destination of the datagram. Generalized-forwarding means that besides its final destination, other factors associated with a datagram is also considered when a router determines the output interface for the datagram. Software defined networking adopts generalized forwarding, for example, forwarding decision can be based on a datagram's TCP/UDP source or destination port numbers, besides its destination IP address.
9. A router uses longest prefix matching to determine which link interface a packet will be forwarded to if the packet's destination address matches two or more entries in the forwarding table. That is, the packet will be forwarded to the link interface that has the longest prefix match with the packet's destination.
10. Switching via memory; switching via a bus; switching via an interconnection network. An interconnection network can forward packets in parallel as long as all the packets are being forwarded to different output ports.
11. If the rate at which packets arrive to the fabric exceeds switching fabric rate, then packets will need to queue at the input ports. If this rate mismatch persists, the queues will get larger and larger and eventually overflow the input port buffers, causing packet loss. Packet loss can be eliminated if the switching fabric speed is at least n times as fast as the input line speed, where n is the number of input ports.
12. Assuming input and output line speeds are the same, packet loss can still occur if the rate at which packets arrive to a single output port exceeds the line speed. If this rate mismatch persists, the queues will get larger and larger and eventually overflow the output port buffers, causing packet loss. Note that increasing switch fabric speed cannot prevent this problem from occurring.
13. HOL blocking: Sometimes a packet that is first in line at an input port queue must wait because there is no available buffer space at the output port to which it wants to be forwarded. When this occurs, all the packets behind the first packet are blocked, even if their output queues have room to accommodate them. HOL blocking occurs at the input port.
14. (A typo in this question: the first question mark should be replaced by a period). Only FIFO can ensure that all packets depart in the order in which they arrived.

15. For example, a packet carrying network management information should receive priority over regular user traffic. Another example, a real-time voice-over-IP packet might need to receive priority over non-real-time traffic such as e-mail.
16. (A typo in the question: different → difference)

With RR, all service classes are treated equally, i.e., no service class has priority over any other service class. With WFQ, service classes are treated differently, i.e., each class may receive a differential amount of service in any interval of time. When a WFQ's all classes have the same amount of service weight, the WFQ is identical to RR.
17. The 8-bit protocol field in the IP datagram contains information about which transport layer protocol the destination host should pass the segment to.
18. Time-to-live.
19. No. IP header checksum only computes the checksum of an IP packet's IP header fields, which share no common bytes with the IP datagram's transport-layer segment part.
20. The reassembly of the fragments of an IP datagram is done in the datagram's destination host.
21. Yes. They have one address for each interface.
22. 11011111 00000001 00000011 00011100.
23. Students will get different correct answers for this question.
24. 8 interfaces; 3 forwarding tables.
25. 50% overhead.
26. Typically the wireless router includes a DHCP server. DHCP is used to assign IP addresses to the 5 PCs and to the router interface. Yes, the wireless router also uses NAT as it obtains only one IP address from the ISP.
27. Route aggregation means that an ISP uses a single prefix to advertise multiple networks. Route aggregation is useful because an ISP can use this technique to advertise to the rest of the Internet a single prefix address for the multiple networks that the ISP has.
28. A plug-and-play or zeroconf protocol means that the protocol is able to automatically configure a host's network-related aspects in order to connect the host into a network.

29. A private network address of a device in a network refers to a network address that is only meaningful to those devices within that network. A datagram with a private network address should never be present in the larger public Internet, because the private network address is potentially used by many network devices within their own private networks.
30. IPv6 has a fixed length header, which does not include most of the options an IPv4 header can include. Even though the IPv6 header contains two 128 bit addresses (source and destination IP address) the whole header has a fixed length of 40 bytes only. Several of the fields are similar in spirit. Traffic class, payload length, next header and hop limit in IPv6 are respectively similar to type of service, datagram length, upper-layer protocol and time to live in IPv4.
31. Yes, because the entire IPv6 datagram (including header fields) is encapsulated in an IPv4 datagram.
32. Forwarding has two main operations: match and action. With destination-based forwarding, the match operation of a router looks up only the destination IP address of the to-be-forwarded datagram, and the action operation of the router involves sending the packet into the switching fabric to a specified output port. With generalized forwarding, the match can be made over multiple header fields associated with different protocols at different layers in the protocol stack, and the action can include forwarding the packet to one or more output ports, load-balancing packets across multiple outgoing interfaces, rewriting header values (as in NAT), purposefully blocking/dropping a packet (as in a firewall), sending a packet to a special server for further processing and action, and more.
33. Each entry in the forwarding table of a destination-based forwarding contains only an IP header field value and the outgoing link interface to which a packet (that matches the IP header field value) is to be forwarded. Each entry of the flow table in OpenFlow includes a set of header field values to which an incoming packet will be matched, a set of counters that are updated as packets are matched to flow table entries, and a set of actions to be taken when a packet matches a flow table entry.
34. “Match plus action” means that a router or a switch tries to find a match between some of the header values of a packet with some entry in a flow table, and then based on that match, the router decides to which interface(s) the packet will be forwarded and even some more operations on the packet. In the case of destination-based forwarding packet switch, a router only tries to find a match between a flow table entry with the destination IP address of an arriving packet, and the action is to decide to which interface(s) the packet will be forwarded. In the case of an SDN, there are many fields can be matched, for example, IP source address, TCP source port, and source MAC address; there are also many actions can be taken, for example, forwarding, dropping, and modifying a field value.

35. Three example header fields in an IP datagram that can be matched in OpenFlow 1.0 generalized forwarding are IP source address, TCP source port, and source MAC address. Three fields that cannot be matched are: TTL field, datagram length field, header checksum (which depends on TTL field).

Chapter 4 Problems

Problem 1

- a) Data destined to host H3 is forwarded through interface 3

Destination Address	Link Interface
H3	3

- b) No, because forwarding rule is only based on destination address.

Problem 2

- a) No, you can only transmit one packet at a time over a shared bus.
- b) No, as discussed in the text, only one memory read/write can be done at a time over the shared system bus.
- c) No, in this case the two packets would have to be sent over the same output bus at the same time, which is not possible.

Problem 3

- a) $(n-1)D$
b) $(n-1)D$
c) 0

Problem 4

The minimal number of time slots needed is 3. The scheduling is as follows.

Slot 1: send X in top input queue, send Y in middle input queue.

Slot 2: send X in middle input queue, send Y in bottom input queue

Slot 3: send Z in bottom input queue.

Largest number of slots is still 3. Actually, based on the assumption that a non-empty input queue is never idle, we see that the first time slot always consists of sending X in the top input queue and Y in either middle or bottom input queue, and in the second time slot, we can always send two more datagram, and the last datagram can be sent in third time slot.

NOTE: Actually, if the first datagram in the bottom input queue is X, then the worst case would require 4 time slots.

Problem 5

a)

Prefix Match	Link Interface
11100000 00	0
11100000 01000000	1
1110000	2
11100001 1	3
otherwise	3

- b) Prefix match for first address is 5th entry: link interface 3
Prefix match for second address is 3rd entry: link interface 2
Prefix match for third address is 4th entry: link interface 3

Problem 6

Destination Address Range	Link Interface
00000000 through 00111111	0
01000000 through 01011111	1
01100000 through 01111111	2
10000000 through 10111111	2
11000000 through 11111111	3

number of addresses for interface 0 = $2^6 = 64$

number of addresses for interface 1 = $2^5 = 32$

number of addresses for interface 2 = $2^6 + 2^5 = 64 + 32 = 96$

number of addresses for interface 3 = $2^6 = 64$

Problem 7

Destination Address Range	Link Interface
11000000 through (32 addresses) 11011111	0
10000000 through(64 addresses) 10111111	1
11100000 through (32 addresses) 11111111	2
00000000 through (128 addresses) 01111111	3

Problem 8

223.1.17.0/26
223.1.17.128/25
223.1.17.192/28

Problem 9

Destination Address	Link Interface
200.23.16/21	0
200.23.24/24	1
200.23.24/21	2
otherwise	3

Problem 10

Destination Address	Link Interface
11100000 00 (224.0/10)	0
11100000 01000000 (224.64/16)	1
1110000 (224/8)	2
11100001 1 (225.128/9)	3
otherwise	3

Problem 11

Any IP address in range 128.119.40.128 to 128.119.40.191

Four equal size subnets: 128.119.40.64/28, 128.119.40.80/28, 128.119.40.96/28, 128.119.40.112/28

Problem 12

From 214.97.254/23, possible assignments are

- a) Subnet A: 214.97.255/24 (256 addresses)
Subnet B: 214.97.254.0/25 - 214.97.254.0/29 (128-8 = 120 addresses)
Subnet C: 214.97.254.128/25 (128 addresses)
- Subnet D: 214.97.254.0/31 (2 addresses)
Subnet E: 214.97.254.2/31 (2 addresses)
Subnet F: 214.97.254.4/30 (4 addresses)
- b) To simplify the solution, assume that no datagrams have router interfaces as ultimate destinations. Also, label D, E, F for the upper-right, bottom, and upper-left interior subnets, respectively.

Router 1

Longest Prefix Match

11010110 01100001 11111111
11010110 01100001 11111110 0000000
11010110 01100001 11111110 0000001

Outgoing Interface

Subnet A
Subnet D
Subnet F

Router 2

Longest Prefix Match

11010110 01100001 11111111 0000000
11010110 01100001 11111110 0
11010110 01100001 11111110 0000001

Outgoing Interface

Subnet D
Subnet B
Subnet E

Router 3

Longest Prefix Match

Outgoing Interface

11010110 01100001 11111111 000001	Subnet F
11010110 01100001 11111110 000001	Subnet E
11010110 01100001 11111110 1	Subnet C

Problem 13

The IP address blocks of Polytechnic Institute of New York University are:

NetRange: 128.238.0.0 - 128.238.255.255
 CIDR: 128.238.0.0/16

The IP address blocks Stanford University are:
 NetRange: 171.64.0.0 - 171.67.255.255
 CIDR: 171.64.0.0/14

The IP address blocks University of Washington are:
 NetRange: 140.142.0.0 - 140.142.255.255
 CIDR: 140.142.0.0/16

No, the whois services cannot be used to determine with certainty the geographical location of a specific IP address.

www.maxmind.com is used to determine the locations of the Web servers at Polytechnic Institute of New York University, Stanford University and University of Washington.

Locations of the Web server at Polytechnic Institute of New York University is

Hostname	Country Code	Country Name	Region	Region Name	City	Postal Code	Latitude	Longitude	ISP	Organization	Metro Code	Area Code
128.238.24.30	US	United States	NY	New York	Brooklyn	11201	40.6944	-73.9906	Polytechnic University	Polytechnic University	501	718

Locations of the Web server Stanford University is

Hostname	Country Code	Country Name	Region	Region Name	City	Postal Code	Latitude	Longitude	ISP	Organization	Metro Code	Area Code
171.64.13.26	US	United States	CA	California	Stanford	94305	37.4178	-122.1720	Stanford University	Stanford University	807	650

Locations of the Web server at University of Massachusetts is

Hostname	Country Code	Country Name	Region	Region Name	City	Postal Code	Latitude	Longitude	ISP	Organization	Metro Code	Area Code
128.119.103.148	US	United States	MA	Massachusetts	Amherst	01003	42.3896	-72.4534	University of Massachusetts	University of Massachusetts	543	413

Problem 14

The maximum size of data field in each fragment = 680 (because there are 20 bytes IP header). Thus the number of required fragments = $\left\lceil \frac{2400 - 20}{680} \right\rceil = 4$

Each fragment will have Identification number 422. Each fragment except the last one will be of size 700 bytes (including IP header). The last datagram will be of size 360 bytes (including IP header). The offsets of the 4 fragments will be 0, 85, 170, 255. Each of the first 3 fragments will have flag=1; the last fragment will have flag=0.

Problem 15

MP3 file size = 5 million bytes. Assume the data is carried in TCP segments, with each TCP segment also having 20 bytes of header. Then each datagram can carry 1500-40=1460 bytes of the MP3 file

Number of datagrams required = $\left\lceil \frac{5 \times 10^6}{1460} \right\rceil = 3425$. All but the last datagram will be 1,500

bytes; the last datagram will be 960+40 = 1000 bytes. Note that here there is no fragmentation – the source host does not create datagrams larger than 1500 bytes, and these datagrams are smaller than the MTUs of the links.

Problem 16

- a) Home addresses: 192.168.1.1, 192.168.1.2, 192.168.1.3 with the router interface being 192.168.1.4
b)

NAT Translation Table

WAN Side	LAN Side
24.34.112.235, 4000	192.168.1.1, 3345
24.34.112.235, 4001	192.168.1.1, 3346
24.34.112.235, 4002	192.168.1.2, 3445
24.34.112.235, 4003	192.168.1.2, 3446
24.34.112.235, 4004	192.168.1.3, 3545
24.34.112.235, 4005	192.168.1.3, 3546

Problem 17

- a) Since all IP packets are sent outside, so we can use a packet sniffer to record all IP packets generated by the hosts behind a NAT. As each host generates a sequence of IP packets with sequential numbers and a distinct (very likely, as they are randomly chosen from a large space) initial identification number (ID), we can group IP packets with consecutive IDs into a cluster. The number of clusters is the number of hosts behind the NAT.

For more practical algorithms, see the following papers.

“A Technique for Counting NATted Hosts”, by Steven M. Bellovin, appeared in IMW’02, Nov. 6-8, 2002, Marseille, France.

“Exploiting the IPID field to infer network path and end-system characteristics.”

Weifeng Chen, Yong Huang, Bruno F. Ribeiro, Kyoungwon Suh, Honggang Zhang, Edmundo de Souza e Silva, Jim Kurose, and Don Towsley.

PAM’05 Workshop, March 31 - April 01, 2005. Boston, MA, USA.

- b) However, if those identification numbers are not sequentially assigned but randomly assigned, the technique suggested in part (a) won’t work, as there won’t be clusters in sniffed data.

Problem 18

It is not possible to devise such a technique. In order to establish a direct TCP connection between Arnold and Bernard, either Arnold or Bob must initiate a connection to the other. But the NATs covering Arnold and Bob drop SYN packets arriving from the WAN side. Thus neither Arnold nor Bob can initiate a TCP connection to the other if they are both behind NATs.

Problem 19

S2 Flow Table	
Match	Action
Ingress Port = 1; IP Src = 10.3.*.*; IP Dst = 10.1.*.*	Forward (2)
Ingress Port = 2; IP Src = 10.1.*.*; IP Dst = 10.3.*.*	Forward (1)
Ingress Port = 1; IP Dst = 10.2.0.3	Forward (3)
Ingress Port = 2; IP Dst = 10.2.0.3	Forward (3)
Ingress Port = 1; IP Dst = 10.2.0.4	Forward (4)
Ingress Port = 2; IP Dst = 10.2.0.4	Forward (4)
Ingress Port = 4	Forward (3)
Ingress Port = 3	Forward (4)

Problem 20

S2 Flow Table	
Match	Action
Ingress Port = 3; IP Dst = 10.1.*.*	Forward (2)
Ingress Port = 3; IP Dst = 10.3.*.*	Forward (2)
Ingress Port = 4; IP Dst = 10.1.*.*	Forward (1)
Ingress Port = 4; IP Dst = 10.3.*.*	Forward (1)

Problem 21

S1 Flow Table	
Match	Action
IP Src = 10.2.*.*; IP Dst = 10.1.0.1	Forward (2)
IP Src = 10.2.*.*; IP Dst = 10.1.0.2	Forward (3)
IP Src = 10.2.*.*; IP Dst = 10.3.*.*	Forward (1)

S3 Flow Table	
Match	Action
IP Src = 10.2.*.*; IP Dst = 10.3.0.6	Forward (1)
IP Src = 10.2.*.*; IP Dst = 10.3.0.5	Forward (2)
IP Src = 10.2.*.*; IP Dst = 10.1.*.*	Forward (3)

Problem 22

S2 Flow Table	
Match	Action
IP Src = 10.1.0.1; IP Dst = 10.2.0.3	Forward (3)
IP Src = 10.1.0.1; IP Dst = 10.2.0.4	Forward (4)
IP Src = 10.3.0.6; IP Dst = 10.2.0.3	Forward (3)
IP Src = 10.3.0.6; IP Dst = 10.2.0.4	Forward (4)

S2 Flow Table	
Match	Action
IP Src = *.*.*.*; IP Dst = 10.2.0.3; port = TCP	Forward (3)
IP Src = *.*.*.*; IP Dst = 10.2.0.4; port = TCP	Forward (4)

S2 Flow Table	
Match	Action
IP Src = *.*.*.*; IP Dst = 10.2.0.3	Forward (3)

S2 Flow Table	
Match	Action
IP Src = 10.1.0.1; IP Dst = 10.2.0.3; port = UDP	Forward (3)

Chapter 5. Review Questions.

1. Per-router control means that a routing algorithm runs in each and every router; both forwarding and routing function are constrained within each router. Each router has a routing component that communicates with the routing components in other routers to compute the values for its forwarding table. In such cases, we say that the network control and data planes are implemented monolithically because each router works as an independent entity that implements its own control and data planes.
2. Logically centralized control means that a logically central routing controller computes and distributes the forwarding tables to be used by each and every router, and each router does not compute its forwarding table, unlike the per-router control. In the case of logically centralized control, the data plane and control plane are implemented in separate devices; the control plane is implemented in a central server or multiple servers, and the data plane is implemented in each router.
3. A centralized routing algorithm computes the least-cost path between a source and destination by using complete, global knowledge about the network. The algorithm needs to have the complete knowledge of the connectivity between all nodes and all links' costs. The actual calculation can be run at one site or could be replicated in the routing component of each and every router. A distributed routing algorithm calculates the least-cost path in an iterative, distributed manner by the routers. With a decentralized algorithm, no node has the complete information about the costs of all network links. Each node begins with only the knowledge of the costs of its own directly attached links, and then through an iterative process of calculation and information exchange with its neighboring nodes, a node gradually calculates the least-cost path to a destination or a set of destinations.

OSPF protocol is an example of centralized routing algorithm, and BGP is an example of a distributed routing algorithm.

4. Link state algorithms: Computes the least-cost path between source and destination using complete, global knowledge about the network. Distance-vector routing: The calculation of the least-cost path is carried out in an iterative, distributed manner. A node only knows the neighbor to which it should forward a packet in order to reach given destination along the least-cost path, and the cost of that path from itself to the destination.
5. The count-to-infinity problem refers to a problem of distance vector routing. The problem means that it takes a long time for a distance vector routing algorithm to converge when there is a link cost increase. For example, consider a network of three nodes x , y , and z . Suppose initially the link costs are $c(x,y)=4$, $c(x,z)=50$, and $c(y,z)=1$. The result of distance-vector routing algorithm says that z 's path to x is $z \rightarrow y \rightarrow x$ and the cost is $5(=4+1)$. When the cost of link (x,y) increases from 4 to 60, it will take 44 iterations of running the distance-vector routing algorithm for node z to realize that its new least-cost path to x is via its direct link to x , and hence y will also realize its least-cost path to x is via z .

6. No. Each AS has administrative autonomy for routing within an AS.
7. Policy: Among ASs, policy issues dominate. It may well be important that traffic originating in a given AS not be able to pass through another specific AS. Similarly, a given AS may want to control what transit traffic it carries between other ASs. Within an AS, everything is nominally under the same administrative control and thus policy issues a much less important role in choosing routes within an AS.

Scale: The ability of a routing algorithm and its data structures to scale to handle routing to/among large numbers of networks is a critical issue in inter-AS routing. Within an AS, scalability is less of a concern. For one thing, if a single administrative domain becomes too large, it is always possible to divide it into two ASs and perform inter-AS routing between the two new ASs.

Performance: Because inter-AS routing is so policy oriented, the quality (for example, performance) of the routes used is often of secondary concern (that is, a longer or more costly route that satisfies certain policy criteria may well be taken over a route that is shorter but does not meet that criteria). Indeed, we saw that among ASs, there is not even the notion of cost (other than AS hop count) associated with routes. Within a single AS, however, such policy concerns are of less importance, allowing routing to focus more on the level of performance realized on a route.

8. False.

With OSPF, a router broadcasts its link-state information to all other routers in the autonomous system to which it belongs, not just to its neighboring routers. This is because with OSPF, each router needs to construct a complete topological map of the entire AS and then locally runs Dijkstra's shortest-path algorithm to determine its least-cost paths to all other nodes in the same AS.

9. An area in an OSPF autonomous system refers to a set of routers, in which each router broadcasts its link state to all other routers in the same set. An OSPF AS can be configured hierarchically into multiple areas, with each area running its own OSPF link-state routing algorithm. Within each area, one or more area border routers are responsible for routing packets outside the area. The concept of area is introduced for scalability reasons, i.e., we would like to build a hierarchical routing for a large scale OSPF AS, and an area is an important building block in hierarchical routing.
10. A subnet is a portion of a larger network; a subnet does not contain a router; its boundaries are defined by the router and host interfaces. A prefix is the network portion of a CIDRized address; it is written in the form a.b.c.d/x ; A prefix covers one or more subnets. When a router advertises a prefix across a BGP session, it includes with the prefix a number of BGP attributes. In BGP jargon, a prefix along with its attributes is a BGP route (or simply a route).

11. Routers use the AS-PATH attribute to detect and prevent looping advertisements; they also use it in choosing among multiple paths to the same prefix. The NEXT-HOP attribute indicates the IP address of the first router along an advertised path (outside of the AS receiving the advertisement) to a given prefix. When configuring its forwarding table, a router uses the NEXT-HOP attribute.
12. A tier-1 ISP B may not carry transit traffic between two other tier-1 ISPs, say A and C, with which B has peering agreements. To implement this policy, ISP B would not advertise to A routes that pass through C; and would not advertise to C routes that pass through A.

13. False.

A BGP router can choose not to add its own identity to the received path and then send that new path on to all of its neighbors, as BGP is a policy-based routing protocol. This can happen in the following scenario. The destination of the received path is some other AS, instead of the BGP router's AS, and the BGP router does not want to work as a transit router.

14. The communication layer is responsible for the communication between the SDN controller and those controlled network devices, via a protocol such as OpenFlow. Through this layer, an SDN controller controls the operation of a remote SDN-enabled switch, host, or other devices, and a device communicates locally-observed events (e.g., a message indicating a link failure) to the controller.

The network-wide state-management layer provides up-to-date information about state a network's hosts, links, switches, and other SDN-controlled devices. A controller also maintains a copy of the flow tables of the various controlled devices.

The network-control application layer represents the brain of SDN control plane. The applications at this layer use the APIs provided by a SDN controller to specify and control the data plane in the network devices. For example, a routing network-control application might determine the end-end paths between sources and destinations. Another network application might perform access control.

15. I would implement a new routing protocol at the SDN's network-control application layer, as this is the layer where a routing protocol determines the end-to-end paths between sources and destinations.

16. The following is a list of types of messages flow across a SDN controller's southbound from the controller to the controlled devices. The recipient of these messages is a controlled packet switch.
 - Configuration. This message allows the controller to query and set a switch's configuration parameters.
 - Modify-state. This message is used by a controller to add/delete or modify entries in the switch's flow table, and to set switch port properties.

- Read-state. This message is used by a controller to collect statistics and counter values from the switch's flow table and ports.
- Send-packet. This message is used by the controller to send a specific packet out of a specified port at the controlled switch.

There are also messages that network-control applications (as senders) send to the controller across the northbound interfaces, for example, messages to read/write network state and flow tables within the state-management layer of the controller.

17. Two types of messages from a controlled device to a controller:

- Flow-removed message. Its purpose is to inform the controller that a flow table entry has been removed, for example, by a timeout or as the result of a received modify-state message.
- Port-status message. Its purpose is to inform the controller of a change in port status.

Two types of messages from a controller to a controlled device:

- Modify-state. The purpose is to add/delete or modify entries in the switch's flow table, and to set switch port properties.
- Read-state. The purpose is to collect statistics and counter values from the switch's flow table and ports.

18. The service abstraction layer allows internal network service applications to communicate with each other. It allows controller components and applications to invoke each other's services and to subscribe to events they generate. This layer also provides a uniform abstract interface to the specific underlying communications protocols in the communication layer, including OpenFlow and SNMP.

19. Echo reply (to ping), type 0, code 0
 Destination network unreachable, type 3 code 0
 Destination host unreachable, type 3, code 1.
 Source quench (congestion control), type 4 code 0.

20.

ICMP warning message (type 11 code 0) and a destination port unreachable ICMP message (type 3 code 3).

21.

A *managing server* is an application, typically with a human in the loop, running in a centralized network management station in a network operation center. It controls the collection, processing, analysis, and/or display of network management information. Actions are initiated in a managing server to control network behavior and a network administrator uses a managing server to interact with the network's devices.

A *managed device* is a piece of network equipment (including its software) that resides on a managed network. A managed device might be a host, router, switch, middlebox, modem, thermometer, or other network-connected device.

A *network management agent* is a process running in a managed device that communicates with a managing server, taking local actions at the managed device under the command and control of the managing server.

Management Information Base (MIB) collects the information associated with those managed objects in a managed network. A MIB object might be a counter, such as the number of IP datagrams discarded at a router due to errors in an IP datagram header, or the number of UDP segments received at a host, or the status information such as whether a particular device is functioning correctly.

22.

GetRequest is a message sent from a managing server to an agent to request the value of one or more MIB objects at the agent's managed device.

SetRequest is a message used by a managing server to set the value of one or more MIB objects in a managed device.

23.

A SNMP trap message is generated as a response to an event happened on a managed device for which the device's managing server requires notification. It is used for notifying a managing server of an exceptional situation (e.g., a link interface going up or down) that has resulted in changes to MIB object values.

Chapter 5. Problems.

Problem 1

$y-x-u$, $y-x-v-u$, $y-x-w-u$, $y-x-w-v-u$,
 $y-w-u$, $y-w-v-u$, $y-w-x-u$, $y-w-x-v-u$, $y-w-v-x-u$,
 $y-z-w-u$, $y-z-w-v-u$, $y-z-w-x-u$, $y-z-w-x-v-u$, $y-z-w-v-x-u$,

Problem 2

x to z:

$x-y-z$, $x-y-w-z$,
 $x-w-z$, $x-w-y-z$,
 $x-v-w-z$, $x-v-w-y-z$,
 $x-u-w-z$, $x-u-w-y-z$,
 $x-u-v-w-z$, $x-u-v-w-y-z$

z to u:

$z-w-u$,
 $z-w-v-u$, $z-w-x-u$, $z-w-v-x-u$, $z-w-x-v-u$, $z-w-y-x-u$, $z-w-y-x-v-u$,
 $z-y-x-u$, $z-y-x-v-u$, $z-y-x-w-u$, $z-y-x-w-y-u$, $z-y-x-v-w-u$,
 $z-y-w-v-u$, $z-y-w-x-u$, $z-y-w-v-x-u$, $z-y-w-x-v-u$, $z-y-w-y-x-u$, $z-y-w-y-x-v-u$

z to w:

$z-w$, $z-y-w$, $z-y-x-w$, $z-y-x-v-w$, $z-y-x-u-w$, $z-y-x-u-v-w$, $z-y-x-v-u-w$

Problem 3

Step	N'	$D(t),p(t)$	$D(u),p(u)$	$D(v),p(v)$	$D(w),p(w)$	$D(y),p(y)$	$D(z),p(z)$
0	x	∞	∞	3,x	6,x	6,x	8,x
1	xv	7,v	6,v	3,x	6,x	6,x	8,x
2	xvu	7,v	6,v	3,x	6,x	6,x	8,x
3	xvuw	7,v	6,v	3,x	6,x	6,x	8,x
4	xvuwyt	7,v	6,v	3,x	6,x	6,x	8,x
5	xvuwyt	7,v	6,v	3,x	6,x	6,x	8,x
6	xvuwytz	7,v	6,v	3,x	6,x	6,x	8,x

Problem 4

a)

Step	N'	$D(x), p(x)$	$D(u), p(u)$	$D(v), p(v)$	$D(w), p(w)$	$D(y), p(y)$	$D(z), p(z)$
0	t	∞	2,t	4,t	∞	7,t	∞
1	tu	∞	2,t	4,t	5,u	7,t	∞
2	tuv	7,v	2,t	4,t	5,u	7,t	∞
3	tuvw	7,v	2,t	4,t	5,u	7,t	∞
4	tuvwx	7,v	2,t	4,t	5,u	7,t	15,x
5	tuvwxy	7,v	2,t	4,t	5,u	7,t	15,x
6	tuvwxyz	7,v	2,t	4,t	5,u	7,t	15,x

b)

Step	N'	$D(x), p(x)$	$D(t), p(t)$	$D(v), p(v)$	$D(w), p(w)$	$D(y), p(y)$	$D(z), p(z)$
	u	∞	2,u	3,u	3,u	∞	∞
	ut	∞	2,u	3,u	3,u	9,t	∞
	utv	6,v	2,u	3,u	3,u	9,t	∞
	utvw	6,v	2,u	3,u	3,u	9,t	∞
	utvwx	6,v	2,u	3,u	3,u	9,t	14,x
	utvwxy	6,v	2,u	3,u	3,u	9,t	14,x
	utvwxyz	6,v	2,u	3,u	3,u	9,t	14,x

c)

Step	N'	$D(x), p(x)$	$D(u), p(u)$	$D(t), p(t)$	$D(w), p(w)$	$D(y), p(y)$	$D(z), p(z)$
	v	3,v	3,v	4,v	4,v	8,v	∞
	vx	3,v	3,v	4,v	4,v	8,v	11,x
	vxu	3,v	3,v	4,v	4,v	8,v	11,x
	vxut	3,v	3,v	4,v	4,v	8,v	11,x
	vxutw	3,v	3,v	4,v	4,v	8,v	11,x
	vxutwy	3,v	3,v	4,v	4,v	8,v	11,x
	vxutwyz	3,v	3,v	4,v	4,v	8,v	11,x

d)

Step	N'	$D(x), p(x)$	$D(u), p(u)$	$D(v), p(v)$	$D(t), p(t)$	$D(y), p(y)$	$D(z), p(z)$
	w	6,w	3,w	4,w	∞	∞	∞
	wu	6,w	3,w	4,w	5,u	∞	∞
	wuv	6,w	3,w	4,w	5,u	12,v	∞

wuvt	6,w	3,w	4,w	5,u	12,v	∞
wuvtx	6,w	3,w	4,w	5,u	12,v	14,x
wuvtxy	6,w	3,w	4,w	5,u	12,v	14,x
wuvtxyz	6,w	3,w	4,w	5,u	12,v	14,x

e)

Step	N'	$D(x), p(x)$	$D(u), p(u)$	$D(v), p(v)$	$D(w), p(w)$	$D(t), p(t)$	$D(z), p(z)$
	y	6,y	∞	8,y	∞	7,y	12,y
	yx	6,y	∞	8,y	12,x	7,y	12,y
	yxt	6,y	9,t	8,y	12,x	7,y	12,y
	yxtv	6,y	9,t	8,y	12,x	7,y	12,y
	yxtvu	6,y	9,t	8,y	12,x	7,y	12,y
	yxtvuw	6,y	9,t	8,y	12,x	7,y	12,y
	yxtvuwz	6,y	9,t	8,y	12,x	7,y	12,y

f)

Step	N'	$D(x), p(x)$	$D(u), p(u)$	$D(v), p(v)$	$D(w), p(w)$	$D(y), p(y)$	$D(t), p(t)$
	z	8,z	∞	∞	∞	12,z	∞
	zx	8,z	∞	11,x	14,x	12,z	∞
	zxv	8,z	14,v	11,x	14,x	12,z	15,v
	zxvy	8,z	14,v	11,x	14,x	12,z	15,v
	zxvyu	8,z	14,v	11,x	14,x	12,z	15,v
	zxvyuw	8,z	14,v	11,x	14,x	12,z	15,v
	zxvyuwt	8,z	14,v	11,x	14,x	12,z	15,v

Problem 5

		Cost to				
		u	v	x	y	z
From	v	∞	∞	∞	∞	∞
	x	∞	∞	∞	∞	∞
	z	∞	6	2	∞	0

		Cost to				
		u	v	x	y	z

	v	1	0	3	∞	6
From	x	∞	3	0	3	2
	z	7	5	2	5	0

Cost to

		u	v	x	y	z
	v	1	0	3	3	5
From	x	4	3	0	3	2
	z	6	5	2	5	0

Cost to

		u	v	x	y	z
	v	1	0	3	3	5
From	x	4	3	0	3	2
	z	6	5	2	5	0

Problem 6

The wording of this question was a bit ambiguous. We meant this to mean, “the number of iterations from when the algorithm is run for the first time” (that is, assuming the only information the nodes initially have is the cost to their nearest neighbors). We assume that the algorithm runs synchronously (that is, in one step, all nodes compute their distance tables at the same time and then exchange tables).

At each iteration, a node exchanges distance tables with its neighbors. Thus, if you are node A, and your neighbor is B, all of B's neighbors (which will all be one or two hops from you) will know the shortest cost path of one or two hops to you after one iteration (i.e., after B tells them its cost to you).

Let d be the “diameter” of the network - the length of the longest path without loops between any two nodes in the network. Using the reasoning above, after $d - 1$ iterations, all nodes will know the shortest path cost of d or fewer hops to all other nodes. Since any path with greater than d hops will have loops (and thus have a greater cost than that path with the loops removed), the algorithm will converge in at most $d - 1$ iterations.

ASIDE: if the DV algorithm is run as a result of a change in link costs, there is no a priori bound on the number of iterations required until convergence unless one also specifies a bound on link costs.

Problem 7

a) $D_x(w) = 2, D_x(y) = 4, D_x(u) = 7$

b) First consider what happens if $c(x,y)$ changes. If $c(x,y)$ becomes larger or smaller (as long as $c(x,y) \geq 1$), the least cost path from x to u will still have cost at least 7. Thus a change in $c(x,y)$ (if $c(x,y) \geq 1$) will not cause x to inform its neighbors of any changes.

If $c(x,y) = \delta < 1$, then the least cost path now passes through y and has cost $\delta + 6$.

Now consider if $c(x,w)$ changes. If $c(x,w) = \epsilon \leq 1$, then the least-cost path to u continues to pass through w and its cost changes to $5 + \epsilon$; x will inform its neighbors of this new cost. If $c(x,w) = \delta > 6$, then the least cost path now passes through y and has cost 11; again x will inform its neighbors of this new cost.

c) Any change in link cost $c(x,y)$ (and as long as $c(x,y) \geq 1$) will not cause x to inform its neighbors of a new minimum-cost path to u .

Problem 8

Node x table

		Cost to		
		x	y	z
From	x	0	3	4
	y	∞	∞	∞
	z	∞	∞	∞

		Cost to		
		x	y	z
From	x	0	3	4
	y	3	0	6
	z	4	6	0

Node y table

		Cost to		
		x	y	z
From	x	∞	∞	∞
	y	3	0	6
	z	∞	∞	∞

		Cost to		
		x	y	z
From	x	∞	∞	∞
	y	3	0	6
	z	∞	∞	∞

	x	0	3	4
From	y	3	0	6
	z	4	6	0

Node z table

		Cost to		
		x	y	z
	x	∞	∞	∞
From	y	∞	∞	∞
	z	4	6	0

		Cost to		
		x	y	z
	x	0	3	4
From	y	3	0	6
	z	4	6	0

Problem 9

NO, this is because that decreasing link cost won't cause a loop (caused by the next-hop relation of between two nodes of that link). Connecting two nodes with a link is equivalent to decreasing the link weight from infinite to the finite weight.

Problem 10

At each step, each updating of a node's distance vectors is based on the Bellman-Ford equation, i.e., only decreasing those values in its distance vector. There is no increasing in values. If no updating, then no message will be sent out. Thus, $D(x)$ is non-increasing. Since those costs are finite, then eventually distance vectors will be stabilized in finite steps.

Problem 11

a)

Router z	Informs w, $D_z(x)=\infty$
	Informs y, $D_z(x)=6$
Router w	Informs y, $D_w(x)=\infty$
	Informs z, $D_w(x)=5$
Router y	Informs w, $D_y(x)=4$
	Informs z, $D_y(x)=4$

b) Yes, there will be a count-to-infinity problem. The following table shows the routing converging process. Assume that at time t_0 , link cost change happens. At time t_1 , y updates its distance vector and informs neighbors w and z. In the following table, " \rightarrow " stands for "informs".

time	t0	t1	t2	t3	t4
Z	→ w, $D_z(x)=\infty$ → y, $D_z(x)=6$		No change	→ w, $D_z(x)=\infty$ → y, $D_z(x)=11$	
W	→ y, $D_w(x)=\infty$ → z, $D_w(x)=5$		→ y, $D_w(x)=\infty$ → z, $D_w(x)=10$		No change
Y	→ w, $D_y(x)=4$ → z, $D_y(x)=4$	→ w, $D_y(x)=9$ → z, $D_y(x)=\infty$		No change	→ w, $D_y(x)=14$ → z, $D_y(x)=\infty$

We see that w, y, z form a loop in their computation of the costs to router x. If we continue the iterations shown in the above table, then we will see that, at t27, z detects that its least cost to x is 50, via its direct link with x. At t29, w learns its least cost to x is 51 via z. At t30, y updates its least cost to x to be 52 (via w). Finally, at time t31, no updating, and the routing is stabilized.

time	t27	t28	t29	t30	t31
Z	→ w, $D_z(x)=50$ → y, $D_z(x)=50$				via w, ∞ via y, 55 via z, 50
W		→ y, $D_w(x)=\infty$ → z, $D_w(x)=50$	→ y, $D_w(x)=51$ → z, $D_w(x)=\infty$		via w, ∞ via y, ∞ via z, 51
Y		→ w, $D_y(x)=53$ → z, $D_y(x)=\infty$		→ w, $D_y(x)=\infty$ → z, $D_y(x)=52$	via w, 52 via y, 60 via z, 53

c) cut the link between y and z.

Problem 12

Since full AS path information is available from an AS to a destination in BGP, loop detection is simple – if a BGP peer receives a route that contains its own AS number in the AS path, then using that route would result in a loop.

Problem 13

The chosen path is not necessarily the shortest AS-path. Recall that there are many issues to be considered in the route selection process. It is very likely that a longer loop-free path is preferred over a shorter loop-free path due to economic reason. For example, an AS might prefer to send traffic to one neighbor instead of another neighbor with shorter AS distance.

Problem 14

a) eBGP

b) iBGP

- c) eBGP
- d) iBGP

Problem 15

- a) I1 because this interface begins the least cost path from 1d towards the gateway router 1c.
- b) I2. Both routes have equal AS-PATH length but I2 begins the path that has the closest NEXT-HOP router.
- c) I1. I1 begins the path that has the shortest AS-PATH.

Problem 16

One way for C to force B to hand over all of B's traffic to D on the east coast is for C to only advertise its route to D via its east coast peering point with C.

Problem 17

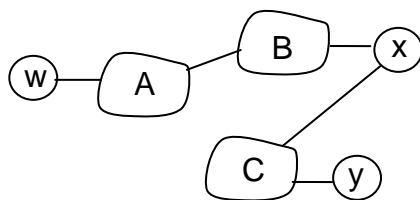

X's view of the topology

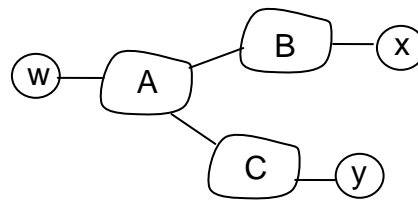

W's view of the topology

In the above solution, X does not know about the AC link since X does not receive an advertised route to w or to y that contain the AC link (i.e., X receives no advertisement containing both AS A and AS C on the path to a destination).

Problem 18

BitTorrent file sharing and Skype P2P applications.

Consider a BitTorrent file sharing network in which peer 1, 2, and 3 are in stub networks W, X, and Y respectively. Due the mechanism of BitTorrent's file sharing, it is quire possible that peer 2 gets data chunks from peer 1 and then forwards those data chunks to 3. This is equivalent to B forwarding data that is finally destined to stub network Y.

Problem 19

A should advise to B two routes, AS-paths A-W and A-V.
A should advise to C only one route, A-V.
C receives AS paths: B-A-W, B-A-V, A-V.

Problem 20

Since Z wants to transit Y's traffic, Z will send route advertisements to Y. In this manner, when Y has a datagram that is destined to an IP that can be reached through Z, Y will have the option of sending the datagram through Z. However, if Z advertizes routes to Y, Y can re-advertize those routes to X. Therefore, in this case, there is nothing Z can do from preventing traffic from X to transit through Z.

Problem 21

Request response mode will generally have more overhead (measured in terms of the number of messages exchanged) for several reasons. First, each piece of information received by the manager requires two messages: the poll and the response. Trapping generates only a single message to the sender. If the manager really only wants to be notified when a condition occurs, polling has more overhead, since many of the polling messages may indicate that the waited-for condition has not yet occurred. Trapping generates a message only when the condition occurs.

Trapping will also immediately notify the manager when an event occurs. With polling, the manager needs will need to wait for half a polling cycle (on average) between when the event occurs and the manager discovers (via its poll message) that the event has occurred.

If a trap message is lost, the managed device will not send another copy. If a poll message, or its response, is lost the manager would know there has been a lost message (since the reply never arrives). Hence the manager could repoll, if needed.

Problem 22

Often, the time when network management is most needed is in times of stress, when the network may be severely congested and packets are being lost. With SNMP running over TCP, TCP's congestion control would cause SNMP to back-off and stop sending messages at precisely the time when the network manager needs to send SNMP messages.

Chapter 6 Review Questions

1. The transportation mode, e.g., car, bus, train, car.
2. Although each link guarantees that an IP datagram sent over the link will be received at the other end of the link without errors, it is not guaranteed that IP datagrams will arrive at the ultimate destination in the proper order. With IP, datagrams in the same TCP connection can take different routes in the network, and therefore arrive out of order. TCP is still needed to provide the receiving end of the application the byte stream in the correct order. Also, IP can lose packets due to routing loops or equipment failures.
3. Framing: there is also framing in IP and TCP; link access; reliable delivery: there is also reliable delivery in TCP; flow control: there is also flow control in TCP; error detection: there is also error detection in IP and TCP; error correction; full duplex: TCP is also full duplex.
4. There will be a collision in the sense that while a node is transmitting it will start to receive a packet from the other node.
5. Slotted Aloha: 1, 2 and 4 (slotted ALOHA is only partially decentralized, since it requires the clocks in all nodes to be synchronized). Token ring: 1, 2, 3, 4.
6. After the 5th collision, the adapter chooses from $\{0, 1, 2, \dots, 31\}$. The probability that it chooses 4 is $1/32$. It waits 204.8 microseconds.
7. In polling, a discussion leader allows only one participant to talk at a time, with each participant getting a chance to talk in a round-robin fashion. For token ring, there isn't a discussion leader, but there is wine glass that the participants take turns holding. A participant is only allowed to talk if the participant is holding the wine glass.
8. When a node transmits a frame, the node has to wait for the frame to propagate around the entire ring before the node can release the token. Thus, if L/R is small as compared to t_{prop} , then the protocol will be inefficient.
9. 2^{48} MAC addresses; 2^{32} IPv4 addresses; 2^{128} IPv6 addresses.
10. C's adapter will process the frames, but the adapter will not pass the datagrams up the protocol stack. If the LAN broadcast address is used, then C's adapter will both process the frames and pass the datagrams up the protocol stack.
11. An ARP query is sent in a broadcast frame because the querying host does not which adapter address corresponds to the IP address in question. For the response, the sending node knows the adapter address to which the response should be sent, so there is no need to send a broadcast frame (which would have to be processed by all the other nodes on the LAN).

12. No it is not possible. Each LAN has its own distinct set of adapters attached to it, with each adapter having a unique LAN address.
13. The three Ethernet technologies have identical frame structures.
14. 2 (the internal subnet and the external internet)
15. In 802.1Q there is a 12-bit VLAN identifier. Thus $2^{12} = 4,096$ VLANs can be supported.
16. We can string the N switches together. The first and last switch would use one port for trunking; the middle N-2 switches would use two ports. So the total number of ports is $2 + 2(N-2) = 2N-2$ ports.

Chapter 6 Problems

Problem 1

```

1 1 1 0 1
0 1 1 0 0
1 0 0 1 0
1 1 0 1 1
1 1 0 0 0

```

Problem 2

Suppose we begin with the initial two-dimensional parity matrix:

```

0 0 0 0
1 1 1 1
0 1 0 1
1 0 1 0

```

With a bit error in row 2, column 3, the parity of row 2 and column 3 is now wrong in the matrix below:

```

0 0 0 0
1 1 0 1
0 1 0 1
1 0 1 0

```

Now suppose there is a bit error in row 2, column 2 and column 3. The parity of row 2 is now correct! The parity of columns 2 and 3 is wrong, but we can't detect in which rows the error occurred!

```

0 0 0 0
1 0 0 1
0 1 0 1
1 0 1 0

```

The above example shows that a double bit error can be detected (if not corrected).

Problem 3

```

01001100 01101001
+ 01101110 01101011
-----

```

```

10111010 11010100
+ 00100000 01001100
-----

```

```

11011011 00100000
+ 01100001 01111001
-----

```

```

00111100 10011010 (overflow, then wrap around)
+ 01100101 01110010
-----

```

10100010 00001100

The one's complement of the sum is 01011101 11110011

Problem 4

a) To compute the Internet checksum, we add up the values at 16-bit quantities:

```

00000001 00000010
00000011 00000100
00000101 00000110
00000111 00001000
00001001 00001010
-----
00011001 00011110

```

The one's complement of the sum is 11100110 11100001.

b) To compute the Internet checksum, we add up the values at 16-bit quantities:

```

01000010 01000011
01000100 01000101
01000110 01000111

```

```

01001000 01001001
01001010 01001011
-----
10011111 10100100

```

The one's complement of the sum is 01100000 01011011

- c) To compute the Internet checksum, we add up the values at 16-bit quantities:

```

01100010 01100011
01100100 01100101
01100110 01100111
01101000 01101001
01101010 01101011

```

```

-----
00000000 00000101

```

The one's complement of the sum is 11111111 11111010.

Problem 5

If we divide 10011 into 1010101010 0000, we get 1011011100, with a remainder of R=0100. Note that, G=10011 is CRC-4-ITU standard.

Problem 6

- we get 1000110000, with a remainder of R=0000.
- we get 0101010101, with a remainder of R=1111.
- we get 1011010111, with a remainder of R=1001.

Problem 7

- Without loss of generality, suppose i th bit is flipped, where $0 \leq i \leq d+r-1$ and assume that the least significant bit is 0th bit.
A single bit error means that the received data is $K = D \cdot 2^r \text{ XOR } R + 2^i$. It is clear that if we divide K by G, then the remainder is not zero. In general, if G contains at least two 1's, then a single bit error can always be detected.
- The key insight here is that G can be divided by 11 (binary number), but any number of odd-number of 1's cannot be divided by 11. Thus, a sequence (not necessarily contiguous) of odd-number bit errors cannot be divided by 11, thus it cannot be divided by G.

Problem 8

a)

$$\begin{aligned}E(p) &= Np(1-p)^{N-1} \\E'(p) &= N(1-p)^{N-1} - Np(N-1)(1-p)^{N-2} \\&= N(1-p)^{N-2}((1-p) - p(N-1))\end{aligned}$$

$$E'(p) = 0 \Rightarrow p^* = \frac{1}{N}$$

b)

$$E(p^*) = N \frac{1}{N} \left(1 - \frac{1}{N}\right)^{N-1} = \left(1 - \frac{1}{N}\right)^{N-1} = \frac{\left(1 - \frac{1}{N}\right)^N}{1 - \frac{1}{N}}$$

$$\lim_{N \rightarrow \infty} \left(1 - \frac{1}{N}\right) = 1 \quad \lim_{N \rightarrow \infty} \left(1 - \frac{1}{N}\right)^N = \frac{1}{e}$$

Thus

$$\lim_{N \rightarrow \infty} E(p^*) = \frac{1}{e}$$

Problem 9

$$\begin{aligned}E(p) &= Np(1-p)^{2(N-1)} \\E'(p) &= N(1-p)^{2(N-2)} - Np2(N-1)(1-p)^{2(N-3)} \\&= N(1-p)^{2(N-3)}((1-p) - p2(N-1))\end{aligned}$$

$$E'(p) = 0 \Rightarrow p^* = \frac{1}{2N-1}$$

$$E(p^*) = \frac{N}{2N-1} \left(1 - \frac{1}{2N-1}\right)^{2(N-1)}$$

$$\lim_{N \rightarrow \infty} E(p^*) = \frac{1}{2} \cdot \frac{1}{e} = \frac{1}{2e}$$

Problem 10

- a) A's average throughput is given by $p_A(1-p_B)$.
Total efficiency is $p_A(1-p_B) + p_B(1-p_A)$.
- b) A's throughput is $p_A(1-p_B) = 2p_B(1-p_B) = 2p_B - 2(p_B)^2$.
B's throughput is $p_B(1-p_A) = p_B(1-2p_B) = p_B - 2(p_B)^2$.
Clearly, A's throughput is not twice as large as B's.
In order to make $p_A(1-p_B) = 2 p_B(1-p_A)$, we need that $p_A = 2 - (p_A / p_B)$.
- c) A's throughput is $2p(1-p)^{N-1}$, and any other node has throughput $p(1-p)^{N-2}(1-2p)$.

Problem 11

- a) $(1 - p(A))^4 p(A)$
where, $p(A)$ = probability that A succeeds in a slot
 $p(A) = p(\text{A transmits and B does not and C does not and D does not})$
 $= p(\text{A transmits}) p(\text{B does not transmit}) p(\text{C does not transmit}) p(\text{D does not transmit})$
 $= p(1 - p) (1 - p)(1-p) = p(1 - p)^3$

Hence, $p(\text{A succeeds for first time in slot 5})$
 $= (1 - p(A))^4 p(A) = (1 - p(1 - p)^3)^4 p(1 - p)^3$

- b) $p(\text{A succeeds in slot 4}) = p(1-p)^3$
 $p(\text{B succeeds in slot 4}) = p(1-p)^3$
 $p(\text{C succeeds in slot 4}) = p(1-p)^3$
 $p(\text{D succeeds in slot 4}) = p(1-p)^3$

$p(\text{either A or B or C or D succeeds in slot 4}) = 4 p(1-p)^3$
(because these events are mutually exclusive)

- c) $p(\text{some node succeeds in a slot}) = 4 p(1-p)^3$
 $p(\text{no node succeeds in a slot}) = 1 - 4 p(1-p)^3$

Hence, $p(\text{first success occurs in slot 3}) = p(\text{no node succeeds in first 2 slots}) p(\text{some node succeeds in 3rd slot}) = (1 - 4 p(1-p)^3)^2 4 p(1-p)^3$

- d) efficiency = $p(\text{success in a slot}) = 4 p(1-p)^3$

Problem 12

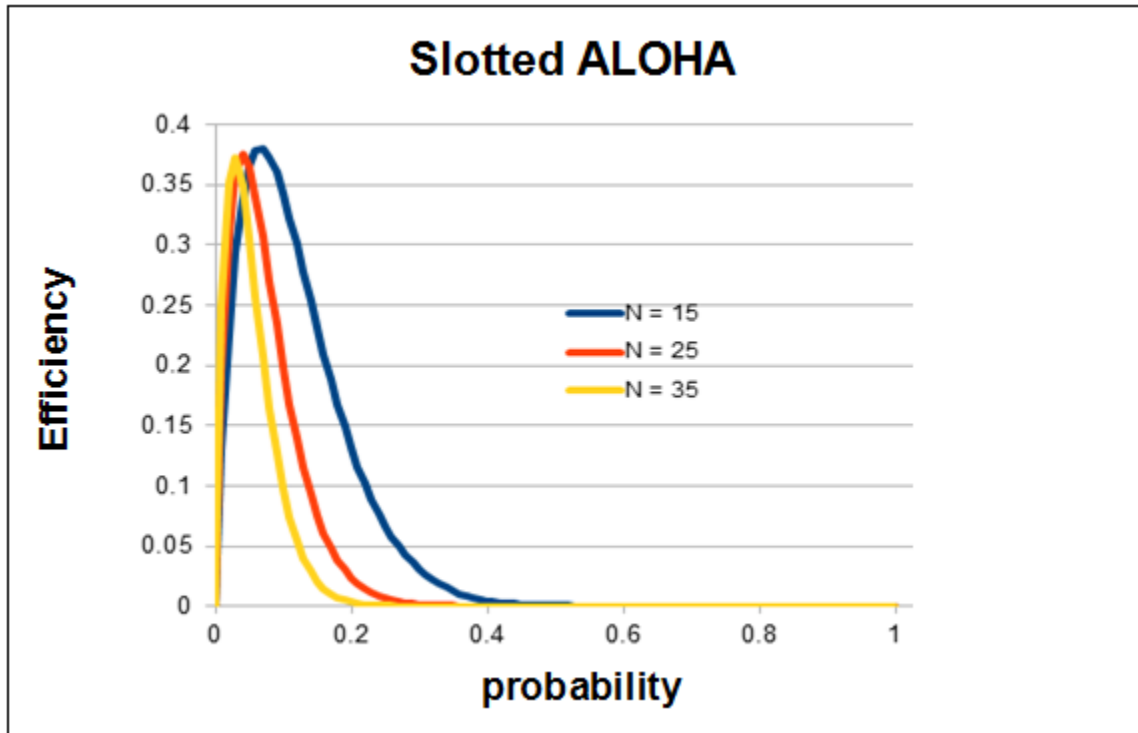
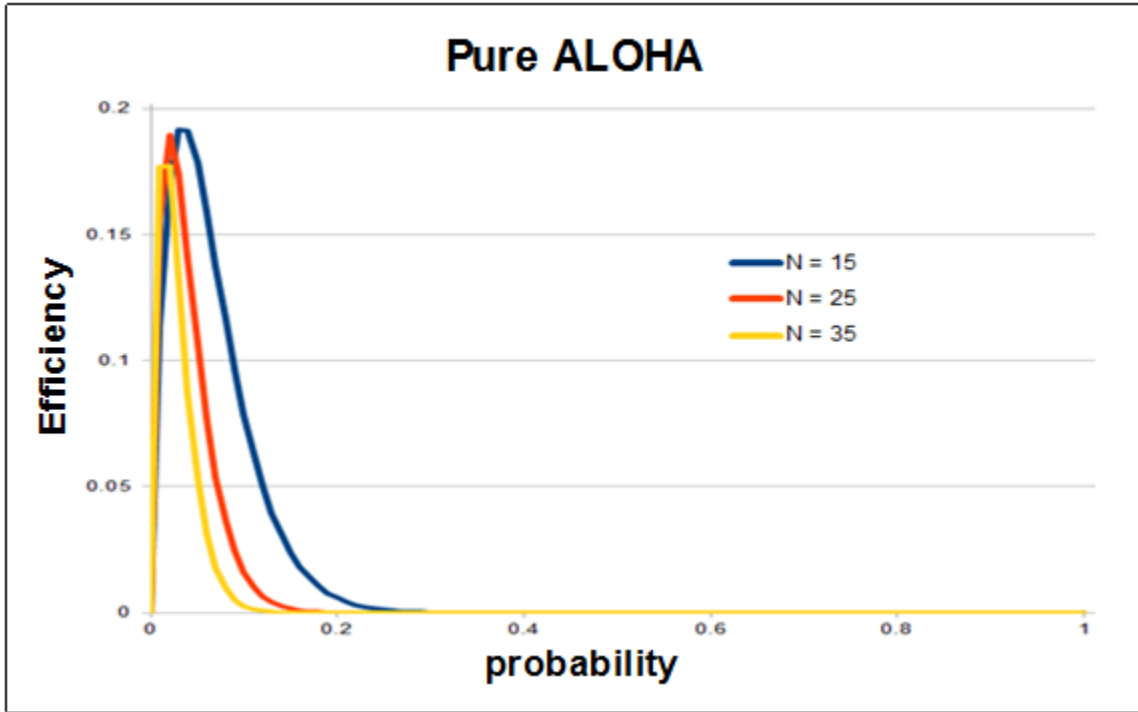

Problem 13

The length of a polling round is

$$N(Q/R + d_{poll}).$$

The number of bits transmitted in a polling round is NQ . The maximum throughput therefore is

$$\frac{NQ}{N(Q/R + d_{poll})} = \frac{R}{1 + \frac{d_{poll}R}{Q}}$$

Problem 14

a), b) See figure below.

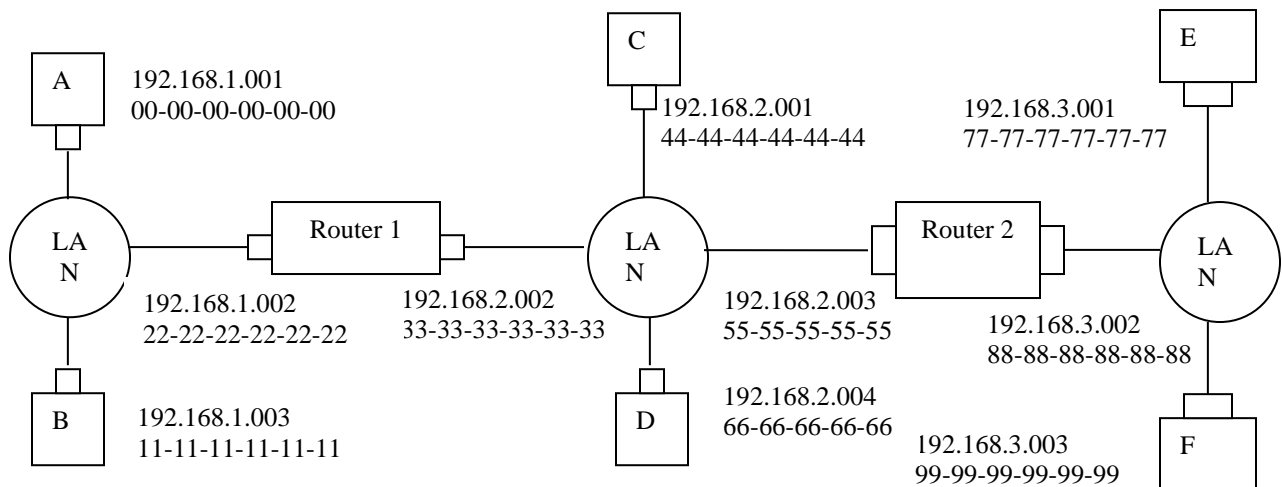

c)

1. Forwarding table in E determines that the datagram should be routed to interface 192.168.3.002.
2. The adapter in E creates an Ethernet packet with Ethernet destination address 88-88-88-88-88-88.
3. Router 2 receives the packet and extracts the datagram. The forwarding table in this router indicates that the datagram is to be routed to 192.162.2.002.
4. Router 2 then sends the Ethernet packet with the destination address of 33-33-33-33-33-33 and source address of 55-55-55-55-55-55 via its interface with IP address of 192.162.2.003.
5. The process continues until the packet has reached Host B.

- d) ARP in E must now determine the MAC address of 198.162.3.002. Host E sends out an ARP query packet within a broadcast Ethernet frame. Router 2 receives the query packet and sends to Host E an ARP response packet. This ARP response packet is carried by an Ethernet frame with Ethernet destination address *77-77-77-77-77-77*.

Problem 15

- a) No. E can check the subnet prefix of Host F's IP address, and then learn that F is on the same LAN. Thus, E will not send the packet to the default router R1.
Ethernet frame from E to F:
Source IP = E's IP address
Destination IP = F's IP address
Source MAC = E's MAC address
Destination MAC = F's MAC address
- b) No, because they are not on the same LAN. E can find this out by checking B's IP address.
Ethernet frame from E to R1:
Source IP = E's IP address
Destination IP = B's IP address
Source MAC = E's MAC address
Destination MAC = The MAC address of R1's interface connecting to Subnet 3.
- c) Switch S1 will broadcast the Ethernet frame via both its interfaces as the received ARP frame's destination address is a broadcast address. And it learns that A resides on Subnet 1 which is connected to S1 at the interface connecting to Subnet 1. And, S1 will update its forwarding table to include an entry for Host A.

Yes, router R1 also receives this ARP request message, but R1 won't forward the message to Subnet 3.

B won't send ARP query message asking for A's MAC address, as this address can be obtained from A's query message.

Once switch S1 receives B's response message, it will add an entry for host B in its forwarding table, and then drop the received frame as destination host A is on the same interface as host B (i.e., A and B are on the same LAN segment).

Problem 16

Lets call the switch between subnets 2 and 3 S2. That is, *router R1 between subnets 2 and 3 is now replaced with switch S2.*

- a) No. E can check the subnet prefix of Host F's IP address, and then learn that F is on the same LAN segment. Thus, E will not send the packet to S2.

Ethernet frame from E to F:

Source IP = E's IP address

Destination IP = F's IP address

Source MAC = E's MAC address

Destination MAC = F's MAC address

- b) Yes, because E would like to find B's MAC address. In this case, E will send an ARP query packet with destination MAC address being the broadcast address.

This query packet will be re-broadcast by switch 1, and eventually received by Host B.

Ethernet frame from E to S2:

Source IP = E's IP address

Destination IP = B's IP address

Source MAC = E's MAC address

Destination MAC = broadcast MAC address: FF-FF-FF-FF-FF-FF.

- c) Switch S1 will broadcast the Ethernet frame via both its interfaces as the received ARP frame's destination address is a broadcast address. And it learns that A resides on Subnet 1 which is connected to S1 at the interface connecting to Subnet 1. And, S1 will update its forwarding table to include an entry for Host A.

Yes, router S2 also receives this ARP request message, and S2 will broadcast this query packet to all its interfaces.

B won't send ARP query message asking for A's MAC address, as this address can be obtained from A's query message.

Once switch S1 receives B's response message, it will add an entry for host B in its forwarding table, and then drop the received frame as destination host A is on the same interface as host B (i.e., A and B are on the same LAN segment).

Problem 17

Wait for 51,200 bit times. For 10 Mbps, this wait is

$$\frac{51.2 \times 10^3 \text{ bits}}{10 \times 10^6 \text{ bps}} = 5.12 \text{ msec}$$

For 100 Mbps, the wait is 512 μ sec.

Problem 18

At $t = 0$ A transmits. At $t = 576$, A would finish transmitting. In the worst case, B begins transmitting at time $t=324$, which is the time right before the first bit of A 's frame arrives at B . At time $t=324+325=649$ B 's first bit arrives at A . Because $649 > 576$, A finishes transmitting before it detects that B has transmitted. So A incorrectly thinks that its frame was successfully transmitted without a collision.

Problem 19

Time, t	Event
0	A and B begin transmission
245	A and B detect collision
293	A and B finish transmitting jam signal
$293+245 = 538$	B 's last bit arrives at A ; A detects an idle channel
$538+96=634$	A starts transmitting
$293+512 = 805$	B returns to Step2 B must sense idle channel for 96 bit times before it transmits
$634+245=879$	A 's transmission reaches B

Because A 's retransmission reaches B before B 's scheduled retransmission time ($805+96$), B refrains from transmitting while A retransmits. Thus A and B do not collide. Thus the factor 512 appearing in the exponential backoff algorithm is sufficiently large.

Problem 20

a) Let Y be a random variable denoting the number of slots until a success:

$$P(Y = m) = \beta(1 - \beta)^{m-1},$$

where β is the probability of a success.

This is a geometric distribution, which has mean $1/\beta$. The number of consecutive wasted slots is $X = Y - 1$ that

$$x = E[X] = E[Y] - 1 = \frac{1 - \beta}{\beta}$$

$$\beta = Np(1 - p)^{N-1}$$

$$x = \frac{1 - Np(1-p)^{N-1}}{Np(1-p)^{N-1}}$$

$$= \frac{k}{k+x} = \frac{k}{k + \frac{1 - Np(1-p)^{N-1}}{Np(1-p)^{N-1}}}$$

efficiency

b)

Maximizing efficiency is equivalent to minimizing x , which is equivalent to maximizing β . We know from the text that β is maximized at $p = \frac{1}{N}$.

c)

$$\text{efficiency} = \frac{k}{k + \frac{1 - (1 - \frac{1}{N})^{N-1}}{(1 - \frac{1}{N})^{N-1}}}$$

$$\lim_{N \rightarrow \infty} \text{efficiency} = \frac{k}{k + \frac{1 - 1/e}{1/e}} = \frac{k}{k + e - 1}$$

d) Clearly, $\frac{k}{k + e - 1}$ approaches 1 as $k \rightarrow \infty$.

Problem 21

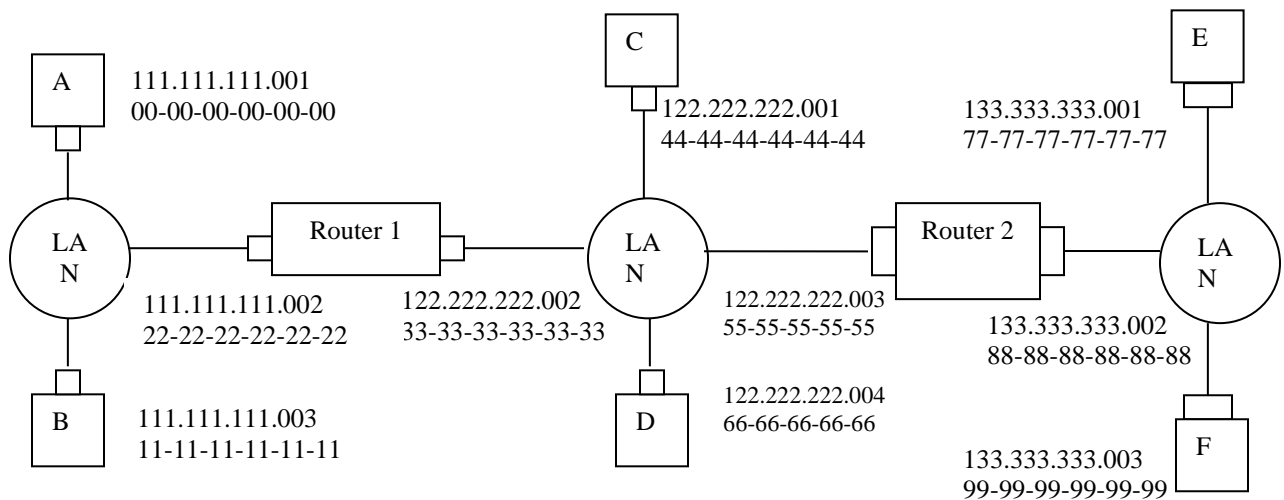

- i) from A to left router: Source MAC address: 00-00-00-00-00-00
Destination MAC address: 22-22-22-22-22-22
Source IP: 111.111.111.001
Destination IP: 133.333.333.003
- ii) from the left router to the right router: Source MAC address: 33-33-33-33-33-33
Destination MAC address: 55-55-55-55-55-55
Source IP: 111.111.111.001
Destination IP: 133.333.333.003
- iii) from the right router to F: Source MAC address: 88-88-88-88-88-88
Destination MAC address: 99-99-99-99-99-99
Source IP: 111.111.111.001
Destination IP: 133.333.333.003

Problem 22

- i) from A to switch: Source MAC address: 00-00-00-00-00-00
Destination MAC address: 55-55-55-55-55-55
Source IP: 111.111.111.001
Destination IP: 133.333.333.003
- ii) from switch to right router: Source MAC address: 00-00-00-00-00-00
Destination MAC address: 55-55-55-55-55-55
Source IP: 111.111.111.001
Destination IP: 133.333.333.003
- iii) from right router to F: Source MAC address: 88-88-88-88-88-88
Destination MAC address: 99-99-99-99-99-99
Source IP: 111.111.111.001
Destination IP: 133.333.333.003

Problem 23

If all the $11=9+2$ nodes send out data at the maximum possible rate of 100 Mbps, a total aggregate throughput of $11*100 = 1100$ Mbps is possible.

Problem 24

Each departmental hub is a single collision domain that can have a maximum throughput of 100 Mbps. The links connecting the web server and the mail server has a maximum throughput of 100 Mbps. Hence, if the three collision domains and the web server and mail server send out data at their maximum possible rates of 100 Mbps each, a maximum total aggregate throughput of 500 Mbps can be achieved among the 11 end systems.

Problem 25

All of the 11 end systems will lie in the same collision domain. In this case, the maximum total aggregate throughput of 100 Mbps is possible among the 11 end systems.

Problem 26

Action	Switch Table State	Link(s) packet is forwarded to	Explanation
B sends a frame to E	Switch learns interface corresponding to MAC address of B	A, C, D, E, and F	Since switch table is empty, so switch does not know the interface corresponding to MAC address of E
E replies with a frame to B	Switch learns interface corresponding to MAC address of E	B	Since switch already knows interface corresponding to MAC address of B
A sends a frame to B	Switch learns the interface corresponding to MAC address of A	B	Since switch already knows the interface corresponding to MAC address of B
B replies with a frame to A	Switch table state remains the same as before	A	Since switch already knows the interface corresponding to MAC address of A

Problem 27

a) The time required to fill $L \cdot 8$ bits is

$$\frac{L \cdot 8}{128 \times 10^3} \text{sec} = \frac{L}{16} \text{msec.}$$

b) For $L = 1,500$, the packetization delay is

$$\frac{1500}{16} \text{ msec} = 93.75 \text{ msec}.$$

For $L = 50$, the packetization delay is

$$\frac{50}{16} \text{ msec} = 3.125 \text{ msec}.$$

c) Store-and-forward delay = $\frac{L \cdot 8 + 40}{R}$

For $L = 1,500$, the delay is

$$\frac{1500 \cdot 8 + 40}{622 \times 10^6} \text{ sec} \approx 19.4 \mu \text{ sec}$$

For $L = 50$, store-and-forward delay $< 1 \mu \text{ sec}$.

d) Store-and-forward delay is small for both cases for typical link speeds. However, packetization delay for $L = 1500$ is too large for real-time voice applications.

Problem 28

The IP addresses for those three computers (from left to right) in EE department are: 111.111.1.1, 111.111.1.2, 111.111.1.3. The subnet mask is 111.111.1/24.

The IP addresses for those three computers (from left to right) in CS department are: 111.111.2.1, 111.111.2.2, 111.111.2.3. The subnet mask is 111.111.2/24.

The router's interface card that connects to port 1 can be configured to contain two sub-interface IP addresses: 111.111.1.0 and 111.111.2.0. The first one is for the subnet of EE department, and the second one is for the subnet of CS department. Each IP address is associated with a VLAN ID. Suppose 111.111.1.0 is associated with VLAN 11, and 111.111.2.0 is associated with VLAN 12. This means that each frame that comes from subnet 111.111.1/24 will be added an 802.1q tag with VLAN ID 11, and each frame that comes from 111.111.2/24 will be added an 802.1q tag with VLAN ID 12.

Suppose that host A in EE department with IP address 111.111.1.1 would like to send an IP datagram to host B (111.111.2.1) in CS department. Host A first encapsulates the IP datagram (destined to 111.111.2.1) into a frame with a destination MAC address equal to the MAC address of the router's interface card that connects to port 1 of the switch. Once the router receives the frame, then it passes it up to IP layer, which decides that the IP datagram should be forwarded to subnet 111.111.2/24 via sub-interface 111.111.2.0. Then the router encapsulates the IP datagram into a frame and sends it to port 1. Note that

this frame has an 802.1q tag VLAN ID 12. Once the switch receives the frame port 1, it knows that this frame is destined to VLAN with ID 12, so the switch will send the frame to Host B which is in CS department. Once Host B receives this frame, it will remove the 802.1q tag.

Problem 29

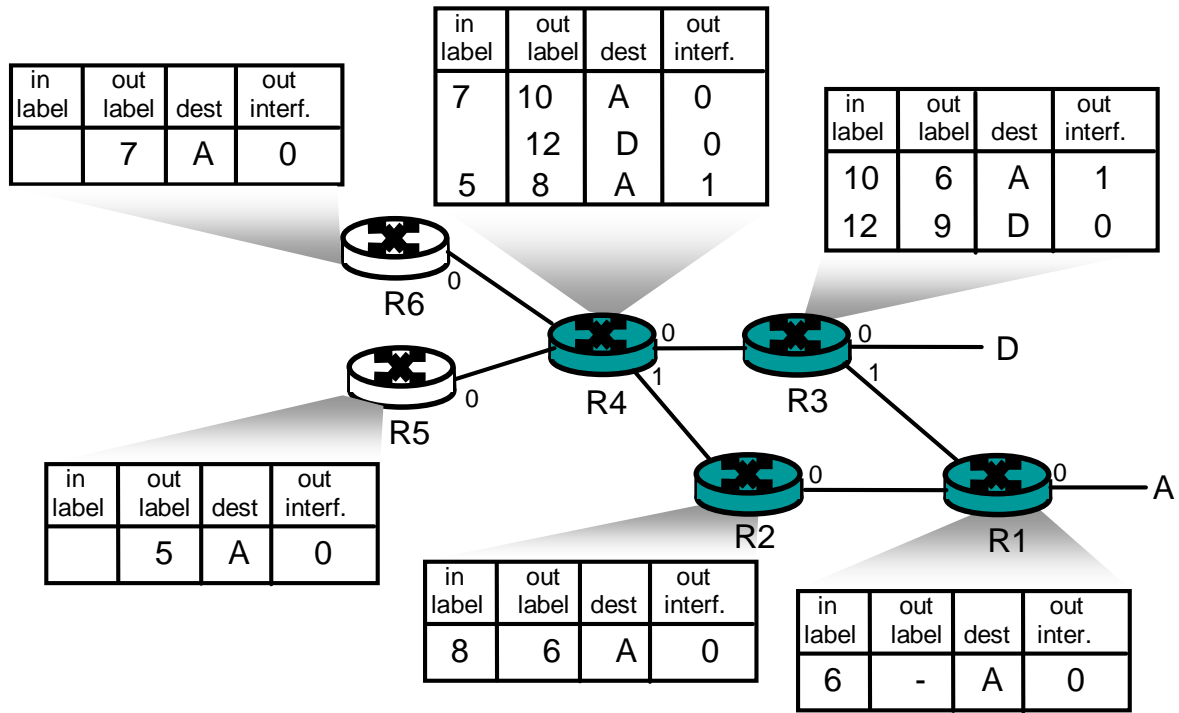

Problem 30

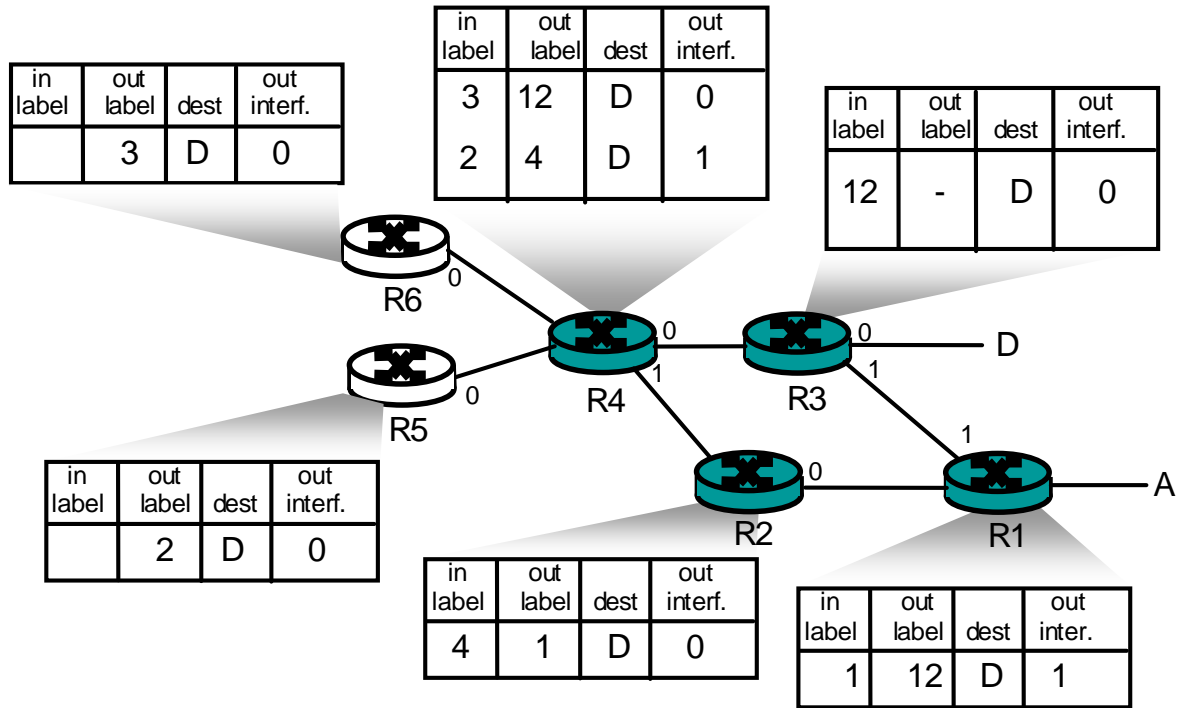

Problem 31

(The following description is short, but contains all major key steps and key protocols involved.)

Your computer first uses DHCP to obtain an IP address. You computer first creates a special IP datagram destined to 255.255.255.255 in the DHCP server discovery step, and puts it in a Ethernet frame and broadcast it in the Ethernet. Then following the steps in the DHCP protocol, you computer is able to get an IP address with a given lease time.

A DHCP server on the Ethernet also gives your computer a list of IP addresses of first-hop routers, the subnet mask of the subnet where your computer resides, and the addresses of local DNS servers (if they exist).

Since your computer's ARP cache is initially empty, your computer will use ARP protocol to get the MAC addresses of the first-hop router and the local DNS server.

Your computer first will get the IP address of the Web page you would like to download. If the local DNS server does not have the IP address, then your computer will use DNS protocol to find the IP address of the Web page.

Once your computer has the IP address of the Web page, then it will send out the HTTP request via the first-hop router if the Web page does not reside in a local Web server. The

HTTP request message will be segmented and encapsulated into TCP packets, and then further encapsulated into IP packets, and finally encapsulated into Ethernet frames. Your computer sends the Ethernet frames destined to the first-hop router. Once the router receives the frames, it passes them up into IP layer, checks its routing table, and then sends the packets to the right interface out of all of its interfaces.

Then your IP packets will be routed through the Internet until they reach the Web server.

The server hosting the Web page will send back the Web page to your computer via HTTP response messages. Those messages will be encapsulated into TCP packets and then further into IP packets. Those IP packets follow IP routes and finally reach your first-hop router, and then the router will forward those IP packets to your computer by encapsulating them into Ethernet frames.

Problem 32

a) Each flow evenly shares a link's capacity with other flows traversing that link, then the 80 flows crossing the B to access-router 10 Gbps links (as well as the access router to border router links) will each only receive $10 \text{ Gbps} / 80 = 125 \text{ Mbps}$

b) In Topology of Figure 5.31, there are four distinct paths between the first and third tier-2 switches, together providing 40 Gbps for the traffic from racks 1-4 to racks 9-12. Similarly, there are four links between second and fourth tier-2 switches, together providing 40 Gbps for the traffic from racks 5-8 to 13-16. Thus the total aggregate bandwidth is 80 Gbps, and the value per flow rate is 1 Gbps.

c) Now 20 flows will need to share each 1 Gbps bandwidth between pairs of TOR switches. So the host-to-host bit rate will be 0.5 Gbps.

Problem 33

a) Both email and video application uses the fourth rack for 0.1 percent of the time.

b) Probability that both applications need fourth rack is $0.001 * 0.001 = 10^{-6}$.

c) Suppose the first three racks are for video, the next rack is a shared rack for both video and email, and the next three racks are for email. Let's assume that the fourth rack has all the data and software needed for both the email and video applications. With the topology of Figure 5.31, both applications will have enough intra-bandwidth as long as both are not simultaneously using the fourth rack. From part b, both are using the fourth rack for no more than .00001 % of time, which is within the .0001% requirement.

Chapter 7 Review Questions

1. In infrastructure mode of operation, each wireless host is connected to the larger network via a base station (access point). If not operating in infrastructure mode, a network operates in ad-hoc mode. In ad-hoc mode, wireless hosts have no infrastructure with which to connect. In the absence of such infrastructure, the hosts themselves must provide for services such as routing, address assignment, DNS-like name translation, and more.
2.
 - a) Single hop, infrastructure-based
 - b) Single hop, infrastructure-less
 - c) Multi-hop, infrastructure-based
 - d) Multi-hop, infrastructure-less
3. Path loss is due to the attenuation of the electromagnetic signal when it travels through matter. Multipath propagation results in blurring of the received signal at the receiver and occurs when portions of the electromagnetic wave reflect off objects and ground, taking paths of different lengths between a sender and receiver. Interference from other sources occurs when the other source is also transmitting in the same frequency range as the wireless network.
4.
 - a) Increasing the transmission power
 - b) Reducing the transmission rate
5. APs transmit beacon frames. An AP's beacon frames will be transmitted over one of the 11 channels. The beacon frames permit nearby wireless stations to discover and identify the AP.
6. False
7. APs transmit beacon frames. An AP's beacon frames will be transmitted over one of the 11 channels. The beacon frames permit nearby wireless stations to discover and identify the AP.
8. False
9. Each wireless station can set an RTS threshold such that the RTS/CTS sequence is used only when the data frame to be transmitted is longer than the threshold. This ensures that RTS/CTS mechanism is used only for large frames.
10. No, there wouldn't be any advantage. Suppose there are two stations that want to transmit at the same time, and they both use RTS/CTS. If the RTS frame is as long as a DATA frames, the channel would be wasted for as long as it would have been

wasted for two colliding DATA frames. Thus, the RTS/CTS exchange is only useful when the RTS/CTS frames are significantly smaller than the DATA frames.

11. Initially the switch has an entry in its forwarding table which associates the wireless station with the earlier AP. When the wireless station associates with the new AP, the new AP creates a frame with the wireless station's MAC address and broadcasts the frame. The frame is received by the switch. This forces the switch to update its forwarding table, so that frames destined to the wireless station are sent via the new AP.
12. Any ordinary Bluetooth node can be a master node whereas access points in 802.11 networks are special devices (normal wireless devices like laptops cannot be used as access points).
13. False
14. "Opportunistic Scheduling" refers to matching the physical layer protocol to channel conditions between the sender and the receiver, and choosing the receivers to which packets will be sent based on channel condition. This allows the base station to make best use of the wireless medium.
15. UMTS to GSM and CDMA-2000 to IS-95.
16. The data plane role of eNodeB is to forward datagram between UE (over the LTE radio access network) and the P-GW. Its control plane role is to handle registration and mobility signaling traffic on behalf of the UE.

The mobility management entity (MME) performs connection and mobility management on behalf of the UEs resident in the cell it controls. It receives UE subscription information from the HHS.

The Packet Data Network Gateway (P-GW) allocates IP addresses to the UEs and performs QoS enforcement. As a tunnel endpoint it also performs datagram encapsulation/decapsulation when forwarding a datagram to/from a UE.

The Serving Gateway (S-GW) is the data-plane mobility anchor point as all UE traffic will pass through the S-GW. The S-GW also performs charging/billing functions and lawful traffic interception.

17. In 3G architecture, there are separate network components and paths for voice and data, i.e., voice goes through public telephone network, whereas data goes through public Internet. 4G architecture is a unified, all-IP network architecture, i.e., both voice and data are carried in IP datagrams to/from the wireless device to several gateways and then to the rest of the Internet.

The 4G network architecture clearly separates data and control plane, which is different from the 3G architecture.

The 4G architecture has an enhanced radio access network (E-UTRAN) that is different from 3G's radio access network UTRAN.

18. No. A node can remain connected to the same access point throughout its connection to the Internet (hence, not be mobile). A mobile node is the one that changes its point of attachment into the network over time. Since the user is always accessing the Internet through the same access point, she is not mobile.

19. A permanent address for a mobile node is its IP address when it is at its home network. A care-of-address is the one it gets when it is visiting a foreign network. The COA is assigned by the foreign agent (which can be the edge router in the foreign network or the mobile node itself).

20. False

21. The home network in GSM maintains a database called the home location register (HLR), which contains the permanent cell phone number and subscriber profile information about each of its subscribers. The HLR also contains information about the current locations of these subscribers. The visited network maintains a database known as the visitor location register (VLR) that contains an entry for each mobile user that is currently in the portion of the network served by the VLR. VLR entries thus come and go as mobile users enter and leave the network.

The edge router in home network in mobile IP is similar to the HLR in GSM and the edge router in foreign network is similar to the VLR in GSM.

22. Anchor MSC is the MSC visited by the mobile when a call first begins; anchor MSC thus remains unchanged during the call. Throughout the call's duration and regardless of the number of inter-MSC transfers performed by the mobile, the call is routed from the home MSC to the anchor MSC, and then from the anchor MSC to the visited MSC where the mobile is currently located.

23. a) Local recovery
b) TCP sender awareness of wireless links
c) Split-connection approaches

Chapter 7 Problems

Problem 1

Output corresponding to bit $d_1 = [-1, 1, -1, 1, -1, 1, -1, 1]$

Output corresponding to bit $d_0 = [1, -1, 1, -1, 1, -1, 1, -1]$

Problem 2

Sender 2 output = $[1, -1, 1, 1, 1, -1, 1, 1]$; $[1, -1, 1, 1, 1, -1, 1, 1]$

Problem 3

$$d_2^1 = \frac{1 \times 1 + (-1) \times (-1) + 1 \times 1 + 1 \times 1 + 1 \times 1 + (-1) \times (-1) + 1 \times 1 + 1 \times 1}{8} = 1$$
$$d_2^2 = \frac{1 \times 1 + (-1) \times (-1) + 1 \times 1 + 1 \times 1 + 1 \times 1 + (-1) \times (-1) + 1 \times 1 + 1 \times 1}{8} = 1$$

Problem 4

Sender 1: $(1, 1, 1, -1, 1, -1, -1, -1)$

Sender 2: $(1, -1, 1, 1, 1, 1, 1, 1)$

Problem 5

- a) The two APs will typically have different SSIDs and MAC addresses. A wireless station arriving to the café will associate with one of the SSIDs (that is, one of the APs). After association, there is a virtual link between the new station and the AP. Label the APs AP1 and AP2. Suppose the new station associates with AP1. When the new station sends a frame, it will be addressed to AP1. Although AP2 will also receive the frame, it will not process the frame because the frame is not addressed to it. Thus, the two ISPs can work in parallel over the same channel. However, the two ISPs will be sharing the same wireless bandwidth. If wireless stations in different ISPs transmit at the same time, there will be a collision. For 802.11b, the maximum aggregate transmission rate for the two ISPs is 11 Mbps.
- b) Now if two wireless stations in different ISPs (and hence different channels) transmit at the same time, there will not be a collision. Thus, the maximum aggregate transmission rate for the two ISPs is 22 Mbps for 802.11b.

Problem 6

Suppose that wireless station H1 has 1000 long frames to transmit. (H1 may be an AP that is forwarding an MP3 to some other wireless station.) Suppose initially H1 is the only station that wants to transmit, but that while half-way through transmitting its first frame, H2 wants to transmit a frame. For simplicity, also suppose every station can hear every other station's signal (that is, no hidden terminals). Before transmitting, H2 will sense that the channel is busy, and therefore choose a random backoff value.

Now suppose that after sending its first frame, H1 returns to step 1; that is, it waits a short period of times (DIFS) and then starts to transmit the second frame. H1's second frame will then be transmitted while H2 is stuck in backoff, waiting for an idle channel. Thus, H1 should get to transmit all of its 1000 frames before H2 has a chance to access the channel. On the other hand, if H1 goes to step 2 after transmitting a frame, then it too chooses a random backoff value, thereby giving a fair chance to H2. Thus, fairness was the rationale behind this design choice.

Problem 7

A frame without data is 32 bytes long. Assuming a transmission rate of 11 Mbps, the time to transmit a control frame (such as an RTS frame, a CTS frame, or an ACK frame) is $(256 \text{ bits}) / (11 \text{ Mbps}) = 23 \text{ usec}$. The time required to transmit the data frame is $(8256 \text{ bits}) / (11 \text{ Mbps}) = 751$

DIFS + RTS + SIFS + CTS + SIFS + FRAME + SIFS + ACK

= DIFS + 3SIFS + (3*23 + 751) usec = DIFS + 3SIFS + 820 usec

Problem 8

- a) 1 message/ 2 slots
- b) 2 messages/slot
- c) 1 message/slot

- d) i) 1 message/slot
ii) 2 messages/slot
iii) 2 messages/slot

- e) i) 1 message/4 slots
ii) slot 1: Message A → B, message D → C
slot 2: Ack B → A
slot 3: Ack C → D

= 2 messages/ 3 slots

iii)

slot 1: Message C → D

slot 2: Ack D → C, message A → B

slot 3: Ack B → A

} Repeat

= 2 messages/3 slots

Problem 10

- a) 10 Mbps if it only transmits to node A. This solution is not fair since only A is getting served. By “fair” it means that each of the four nodes should be allotted equal number of slots.
- b) For the fairness requirement such that each node receives an equal amount of data during each downstream sub-frame, let n_1 , n_2 , n_3 , and n_4 respectively represent the number of slots that A, B, C and D get.

Now,

data transmitted to A in 1 slot = $10t$ Mbits

(assuming the duration of each slot to be t)

Hence,

Total amount of data transmitted to A (in n_1 slots) = $10t n_1$

Similarly total amounts of data transmitted to B, C, and D equal to $5t n_2$, $2.5t n_3$, and $t n_4$ respectively.

Now, to fulfill the given fairness requirement, we have the following condition:

$$10t n_1 = 5t n_2 = 2.5t n_3 = t n_4$$

Hence,

$$n_2 = 2 n_1$$

$$n_3 = 4 n_1$$

$$n_4 = 10 n_1$$

Now, the total number of slots is N . Hence,

$$n_1 + n_2 + n_3 + n_4 = N$$

$$\text{i.e. } n_1 + 2 n_1 + 4 n_1 + 10 n_1 = N$$

$$\text{i.e. } n_1 = N/17$$

Hence,

$$n_2 = 2N/17$$

$$n_3 = 4N/17$$

$$n_4 = 10N/17$$

The average transmission rate is given by:

$$\begin{aligned} & (10t n_1 + 5t n_2 + 2.5t n_3 + t n_4) / tN \\ & = (10N/17 + 5 * 2N/17 + 2.5 * 4N/17 + 1 * 10N/17) / N \\ & = 40/17 = 2.35 \text{ Mbps} \end{aligned}$$

- c) Let node A receives twice as much data as nodes B, C, and D during the sub-frame.

Hence,

$$10tn_1 = 2 * 5tn_2 = 2 * 2.5tn_3 = 2 * tn_4$$

$$\text{i.e. } n_2 = n_1$$

$$n_3 = 2n_1$$

$$n_4 = 5n_1$$

Again,

$$n_1 + n_2 + n_3 + n_4 = N$$

$$\text{i.e. } n_1 + n_1 + 2n_1 + 5n_1 = N$$

$$\text{i.e. } n_1 = N/9$$

Now, average transmission rate is given by:

$$\begin{aligned} & (10t n_1 + 5t n_2 + 2.5t n_3 + t n_4) / tN \\ & = 25/9 = 2.78 \text{ Mbps} \end{aligned}$$

Similarly, considering nodes B, C, or D receive twice as much data as any other nodes, different values for the average transmission rate can be calculated.

Problem 11

- a) No. All the routers might not be able to route the datagram immediately. This is because the Distance Vector algorithm (as well as the inter-AS routing protocols like BGP) is decentralized and takes some time to terminate. So, during the time when the algorithm is still running as a result of advertisements from the new foreign network, some of the routers may not be able to route datagrams destined to the mobile node.
- b) Yes. This might happen when one of the nodes has just left a foreign network and joined a new foreign network. In this situation, the routing entries from the old foreign network might not have been completely withdrawn when the entries from the new network are being propagated.
- c) The time it takes for a router to learn a path to the mobile node depends on the number of hops between the router and the edge router of the foreign network for the node.

Problem 12

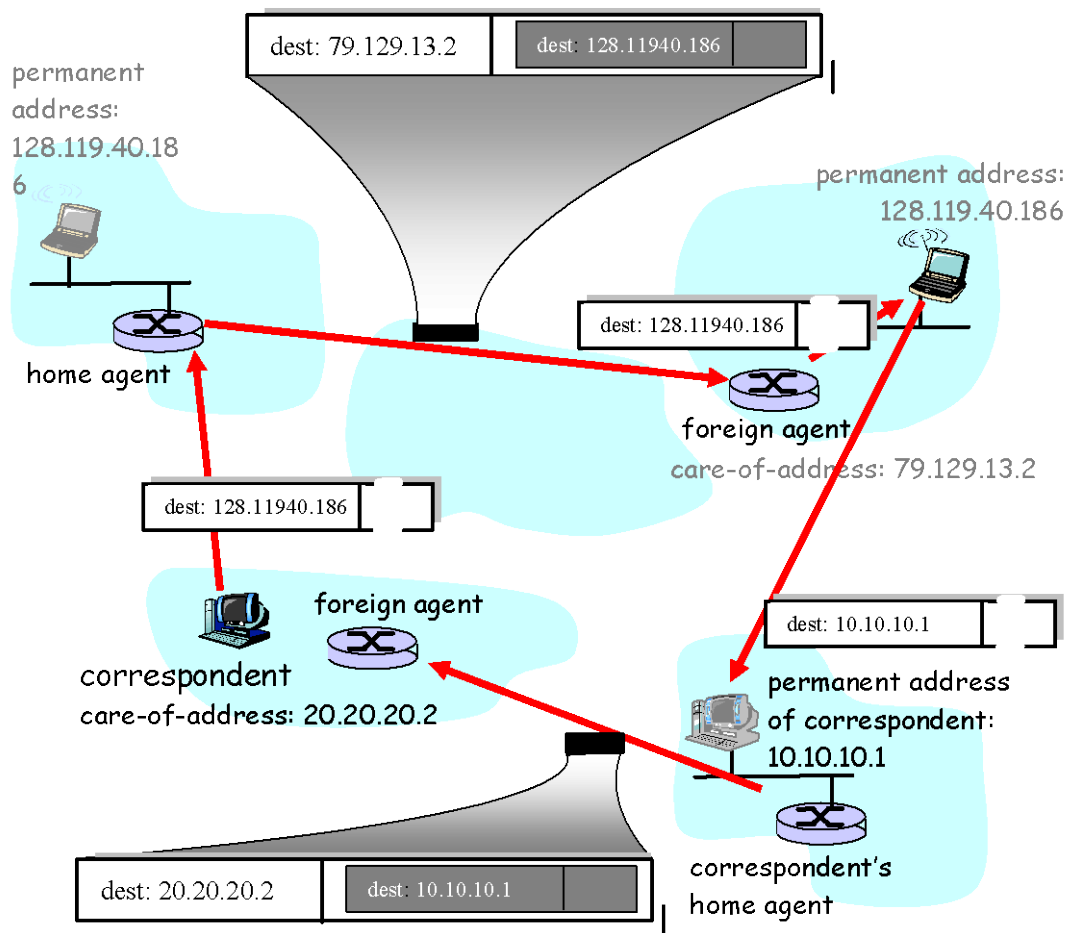

If the correspondent is mobile, then any datagrams destined to the correspondent would have to pass through the **correspondent's home agent**. The **foreign agent** in the network being visited would also need to be involved, since it is this foreign agent that notifies the correspondent's home agent of the location of the correspondent. Datagrams received by the correspondent's home agent would need to be encapsulated/tunneled between the correspondent's home agent and foreign agent, (as in the case of the encapsulated diagram at the top of Figure 6.23).

Problem 13

Because datagrams must be first forward to the home agent, and from there to the mobile, the delays will generally be longer than via direct routing. Note that it *is* possible, however, that the direct delay from the correspondent to the mobile (i.e., if the datagram is not routed through the home agent) could actually be smaller than the sum of the delay

from the correspondent to the home agent and from there to the mobile. It would depend on the delays on these various path segments. Note that indirect routing also adds a home agent processing (e.g., encapsulation) delay.

Problem 14

First, we note that chaining was discussed at the end of section 6.5. In the case of chaining using indirect routing through a home agent, the following events would happen:

- The mobile node arrives at A, A notifies the home agent that the mobile is now visiting A and that datagrams to the mobile should now be forwarded to the specified care-of-address (COA) in A.
- The mobile node moves to B. The foreign agent at B must notify the foreign agent at A that the mobile is no longer resident in A but in fact is resident in B and has the specified COA in B. From then on, the foreign agent in A will forward datagrams it receives that are addressed to the mobile's COA in A to the mobile's COA in B.
- The mobile node moves to C. The foreign agent at C must notify the foreign agent at B that the mobile is no longer resident in B but in fact is resident in C and has the specified COA in C. From then on, the foreign agent in B will forward datagrams it receives (from the foreign agent in A) that are addressed to the mobile's COA in B to the mobile's COA in C.

Note that when the mobile goes offline (i.e., has no address) or returns to its home network, the datagram-forwarding state maintained by the foreign agents in A, B and C must be removed. This teardown must also be done through signaling messages. Note that the home agent is not aware of the mobile's mobility beyond A, and that the correspondent is not at all aware of the mobile's mobility.

In the case that chaining is not used, the following events would happen:

- The mobile node arrives at A, A notifies the home agent that the mobile is now visiting A and that datagrams to the mobile should now be forwarded to the specified care-of-address (COA) in A.
- The mobile node moves to B. The foreign agent at B must notify the foreign agent at A and the home agent that the mobile is no longer resident in A but in fact is resident in B and has the specified COA in B. The foreign agent in A can remove its state about the mobile, since it is no longer in A. From then on, the home agent will forward datagrams it receives that are addressed to the mobile's COA in B.
- The mobile node moves to C. The foreign agent at C must notify the foreign agent at B and the home agent that the mobile is no longer resident in B but in fact is resident in C and has the specified COA in C. The foreign agent in B can remove its state about the mobile, since it is no longer in B. From then on, the home agent will forward datagrams it receives that are addressed to the mobile's COA in C.

When the mobile goes offline or returns to its home network, the datagram-forwarding state maintained by the foreign agent in C must be removed. This teardown must also be done through signaling messages. Note that the home agent is always aware of the mobile's current foreign network. However, the correspondent is still blissfully unaware of the mobile's mobility.

Problem 15

Two mobiles could certainly have the same care-of-address in the same visited network. Indeed, if the care-of-address is the address of the foreign agent, then this address would be the same. Once the foreign agent decapsulates the tunneled datagram and determines the address of the mobile, then separate addresses would need to be used to send the datagrams separately to their different destinations (mobiles) within the visited network.

Problem 16

If the MSRN is provided to the HLR, then the value of the MSRN must be updated in the HLR whenever the MSRN changes (e.g., when there is a handoff that requires the MSRN to change). The advantage of having the MSRN in the HLR is that the value can be provided quickly, without querying the VLR. By providing the address of the VLR (rather than the MSRN), there is no need to be refreshing the MSRN in the HLR.

Chapter 8 Review Questions

1. Confidentiality is the property that the original plaintext message can not be determined by an attacker who intercepts the ciphertext-encryption of the original plaintext message. Message integrity is the property that the receiver can detect whether the message sent (whether encrypted or not) was altered in transit. The two are thus different concepts, and one can have one without the other. An encrypted message that is altered in transmit may still be confidential (the attacker can not determine the original plaintext) but will not have message integrity if the error is undetected. Similarly, a message that is altered in transit (and detected) could have been sent in plaintext and thus would not be confidential.
2. User's laptop and a web server; (ii) two routers; (iii) two DNS name servers.
3. One important difference between symmetric and public key systems is that in symmetric key systems both the sender and receiver must know the same (secret) key. In public key systems, the encryption and decryption keys are distinct. The encryption key is known by the entire world (including the sender), but the decryption key is known only by the receiver.
4. In this case, a known plaintext attack is performed. If, somehow, the message encrypted by the sender was chosen by the attacker, then this would be a chosen-plaintext attack.
5. An 8-block cipher has 2^8 possible input blocks. Each mapping is a permutation of the 2^8 input blocks; so there are $2^8!$ possible mappings; so there are $2^8!$ possible keys.
6. If each user wants to communicate with N other users, then each pair of users must have a shared symmetric key. There are $N*(N-1)/2$ such pairs and thus there are $N*(N-1)/2$ keys. With a public key system, each user has a public key which is known to all, and a private key (which is secret and only known by the user). There are thus $2N$ keys in the public key system.
7. $a \bmod n = 23$, $b \bmod n = 4$. So $(a*b) \bmod n = 23*4=92$
8. 175
9. One requirement of a message digest is that given a message M , it is very difficult to find another message M' that has the same message digest and, as a corollary, that given a message digest value it is difficult to find a message M'' that has that given message digest value. We have "message integrity" in the sense that we have reasonable confidence that given a message M and its signed message digest that the message was not altered since the message digest was computed and signed. This is

not true of the Internet checksum, where we saw in Figure 7.18 that it is easy to find two messages with the same Internet checksum.

10. No. This is because a hash function is a one-way function. That is, given any hash value, the original message cannot be recovered (given h such that $h=H(m)$, one cannot recover m from h).
11. This scheme is clearly flawed. Trudy, an attacker, can first sniff the communication and obtain the shared secret s by extracting the last portion of digits from $H(m)+s$. Trudy can then masquerade as the sender by creating her own message t and send $(t, H(t)+s)$.
12. Suppose Bob sends an encrypted document to Alice. To be verifiable, Alice must be able to convince herself that Bob sent the encrypted document. To be non-forgeable, Alice must be able to convince herself that only Bob could have sent the encrypted document (e.g., no one else could have guessed a key and encrypted/sent the document). To be non-reputable, Alice must be able to convince someone else that only Bob could have sent the document. To illustrate the latter distinction, suppose Bob and Alice share a secret key, and they are the only ones in the world who know the key. If Alice receives a document that was encrypted with the key, and knows that she did not encrypt the document herself, then the document is known to be verifiable and non-forgeable (assuming a suitably strong encryption system was used). However, Alice cannot convince someone else that Bob must have sent the document, since in fact Alice knew the key herself and could have encrypted/sent the document.
13. A public-key signed message digest is “better” in that one need only encrypt (using the private key) a short message digest, rather than the entire message. Since public key encryption with a technique like RSA is expensive, it’s desirable to have to sign (encrypt) a smaller amount of data than a larger amount of data.
14. This is false. To create the certificate, certifier.com would include a digital signature, which is a hash of foo.com’s information (including its public key), and signed with certifier.com’s private key.
15. For a MAC-based scheme, Alice would have to establish a shared key with each potential recipient. With digital signatures, she uses the same digital signature for each recipient; the digital signature is created by signing the hash of the message with her private key. Digital signatures are clearly a better choice here.
16. The purpose of the nonce is to defend against the replay attack.
17. Once in a lifetime means that the entity sending the nonce will never again use that value to check whether another entity is “live”.

18. In a man-in-the-middle attack, the attacker puts himself between Alice and Bob, altering the data sent between them. If Bob and Alice share a secret authentication key, then any alterations will be detected.
19. Alice provides a digital signature, from which Bob can verify that message came from Alice. PGP uses digital signatures, not MACs, for message integrity.
20. False. SSL uses implicit sequence numbers.
21. The purpose of the random nonces in the handshake is to defend against the connection replay attack.
22. True. The IV is always sent in the clear. In SSL, it is sent during the SSL handshake.
23. After the client will generate a pre-master secret (PMS), it will encrypt it with Alice's public key, and then send the encrypted PMS to Trudy. Trudy will not be able to decrypt the PMS, since she does not have Alice's private key. Thus Trudy will not be able to determine the shared authentication key. She may instead guess one by choosing a random key. During the last step of the handshake, she sends to Bob a MAC of all the handshake messages, using the guessed authentication key. When Bob receives the MAC, the MAC test will fail, and Bob will end the TCP connection.
24. False. Typically an IPsec SA is first established between Host A and Host B. Then all packets in the stream use the SA.
25. False. IPsec will increment the sequence number for every packet it sends.
26. False. An IKE SA is used to establish one or more IPsec SAs.
27. 01011100
28. True
29. Filter table and connection table. The connection table keeps track of connections, allowing for a finer degree of packet filtering.
30. True
31. True
32. If there isn't a packet filter, than users inside the institution's network will still be able to make direct connections to hosts outside the institution's network. The filter forces the users to first connect to the application gateway.
33. True

Chapter 8 Problems

Problem 1

The encoding of “This is an easy problem” is “uasi si my cmiw lokngch”.

The decoding of “rmij'u uamu xyj” is “wasn't that fun”.

Problem 2

If Trudy knew that the words “bob” and “alice” appeared in the text, then she would know the ciphertext for b,o,a,l,i,c,e (since “bob” is the only palindrome in the message, and “alice” is the only 5-letter word. If Trudy knows the ciphertext for 7 of the letters, then she only needs to try $19!$, rather than $26!$, plaintext-ciphertext pairs. The difference between $19!$ and $26!$ is $26*25*24...*20$, which is 3315312000, or approximately 10^9 .

Problem 3

Every letter in the alphabet appears in the phrase “The quick fox jumps over the lazy brown dog.” Given this phrase in a chosen plaintext attack (where the attacker has both the plain text, and the ciphertext), the Caesar cipher would be broken - the intruder would know the ciphertext character for every plaintext character. However, the Vigenere cipher does not always translate a given plaintext character to the same ciphertext character each time, and hence a Vigenere cipher would not be immediately broken by this chosen plaintext attack.

Problem 4

- The output is equal to 00000101 repeated eight times.
- The output is equal to 00000101 repeated seven times + 10000101.
- We have $(ARBR)R = CBA$, where A, B, C are strings, and R means inverse operation. Thus:
 - For (a), the output is 10100000 repeated eight times;
 - For (b), the output is 10100001 + 10100000 repeated seven times.

Problem 5

- There are 8 tables. Each table has 28 entries. Each entry has 8 bits.
number of tables * size of each table * size of each entry = $8*28*8 = 214$ bits
- There are 264 entries. Each entry has 64 bits. 271 bits

Problem 6

- 100100100 \implies 011011011
- Trudy will know the three block plaintexts are the same.
- $c(i) = KS(m(i) \text{ XOR } c(i-1))$
 $c(1) = KS(100 \text{ XOR } 111) = KS(011) = 100$
 $c(2) = KS(100 \text{ XOR } 100) = KS(000) = 110$
 $c(3) = KS(100 \text{ XOR } 110) = KS(010) = 101$

Problem 7

- a) We are given $p = 3$ and $q = 11$. We thus have $n = 33$ and $\phi(n) = 20$. Choose $e = 9$ (it might be a good idea to give students a hint that 9 is a good value to choose, since the resulting calculations are less likely to run into numerical stability problems than other choices for e .) since 3 and $(p-1)(q-1) = 20$ have no common factors. Choose $d = 9$ also so that $e \cdot d = 81$ and thus $e \cdot d - 1 = 80$ is exactly divisible by 20. We can now perform the RSA encryption and decryption using $n = 33$, $e = 9$ and $d = 9$.

letter	m	$m^{**}e$	ciphertext = $m^{**}e \bmod 33$
d	4	262144	25
o	15	38443359375	3
g	7	40353607	19

ciphertext	$c^{**}d$	$m = c^{**}d \bmod n$	letter
25	38146972265625	4	d
3	19683	15	o
19	322687697779	7	g

We first consider each letter as a 5-bit number: 00100, 01111, 00111. Now we concatenate each letter to get 001000111100111 and encrypt the resulting decimal number $m=4583$. The concatenated decimal number $m (= 4583)$ is larger than current $n (= 33)$. We need $m < n$. So we use $p = 43$, $q = 107$, $n = p \cdot q = 4601$, $z = (p-1)(q-1) = 4452$. $e = 61$, $d = 73$

$$\text{ciphertext} = m^{**}e \bmod 4601$$

$m^{**}e = 21386577601828057804089602156530567188611499869029788733808438$
 $804302864595620613956725840720949764845640956118784875246785033236197$
 $777129730258961756918400292048632806197527785447791567255101894492820$
 972508185769802881718983

$$\text{ciphertext} = m^{**}e \bmod 4601 = 402$$

$c^{**}d$
 $= 1283813313619771634195712132539793287643533147482536209328405262793$
 $027158861012392053287249633570967493122280221453815012934241370540204$
 $5814598714979387232141014703227794586499817945633390592$

$$\text{ciphertext} = m^{**}e \bmod 4601 = 4583$$

Problem 8

$p = 5, q = 11$

- a) $n = p \cdot q = 55, z = (p-1)(q-1) = 40$
- b) $e = 3$ is less than n and has no common factors with z .
- c) $d = 27$
- d) $m = 8, me = 512, \text{Ciphertext } c = me \bmod n = 17$

Problem 9

	<u>Alice</u>	<u>Bob</u>
secret key:	S_A	S_B
public key:	$T_A = (g^{S_A}) \bmod p$	$T_B = (g^{S_B}) \bmod p$
shared key:	$S = (T_B^{S_A}) \bmod p$	$S' = (T_A^{S_B}) \bmod p$

a) $S = (T_B^{S_A}) \bmod p = ((g^{S_B} \bmod p)^{S_A}) \bmod p = (g^{(S_B S_A)}) \bmod p$
 $= ((g^{S_A} \bmod p)^{S_B}) \bmod p = (T_A^{S_B}) \bmod p = S'$

(b and c) $p = 11, g = 2$

	<u>Alice</u>	<u>Bob</u>
secret key:	$S_A = 5$	$S_B = 12$
public key:	$T_A = (g^{S_A}) \bmod p = 10$	$T_B = (g^{S_B}) \bmod p = 4$
shared key:	$S = (T_B^{S_A}) \bmod p = 1$	$S' = (T_A^{S_B}) \bmod p = 1$

d)

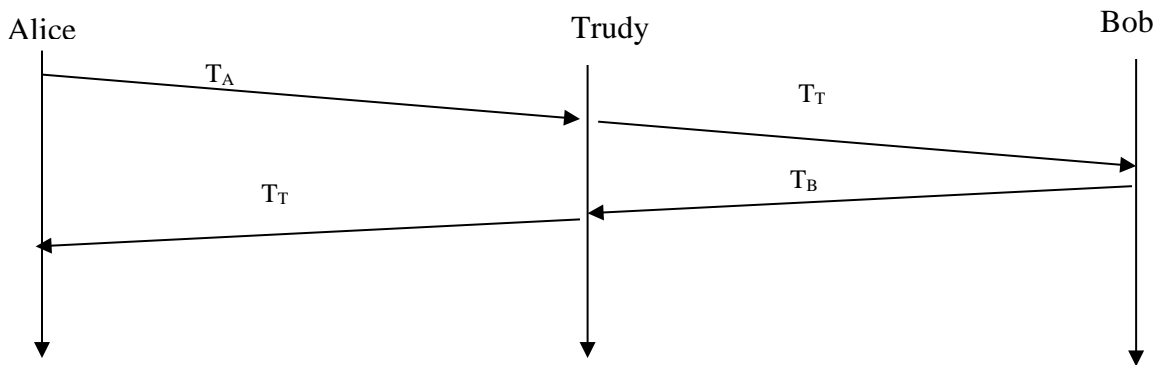

The Diffie-Hellman public key encryption algorithm is possible to be attacked by man-in-the-middle.

1. In this attack, Trudy receives Alice's public value (T_A) and sends her own public value (T_T) to Bob.
2. When Bob transmits his public value (T_B), Trudy sends her public key to Alice (T_T).
3. Trudy and Alice thus agree on one shared key (S_{AT}) and Trudy and Bob agree on another shared key (S_{BT}).

- After this exchange, Trudy simply decrypts any messages sent out by Alice or Bob by the public keys S_{AT} and S_{BT} .

Problem 10

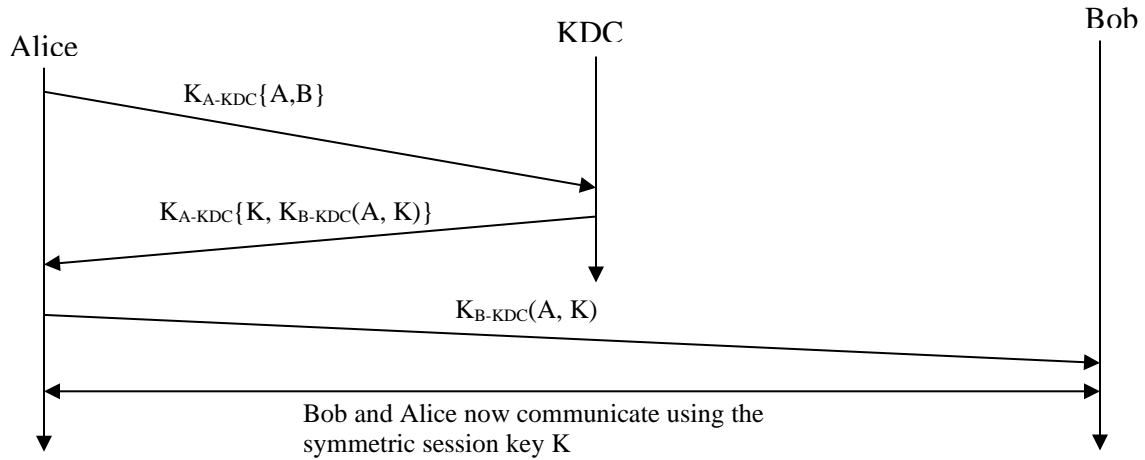

Problem 11

The message

I	O	U	1
9	0	.	9
0	B	O	B

has the same checksum

Problem 12

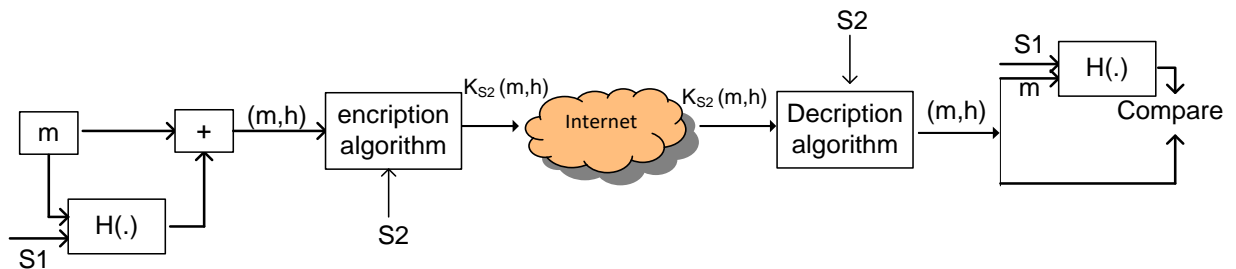

Problem 13

The file is broken into blocks of equal size. For each block, calculate the hash (for example with MD5 or SHA-1). The hashes for all of the blocks are saved in the .torrent file. Whenever a peer downloads a block, it calculates the hash of this block and compares it to the hash in the .torrent file. If the two hashes are equal, the block is valid. Otherwise, the block is bogus, and should be discarded.

Problem 14

Digital signatures require an underlying Public Key Infrastructure (PKI) with certification authorities. For OSPF, all routers are in a same domain, so the administrator can easily deploy the symmetric key on each router, without the need of a PKI.

Problem 15

Bob does not know if he is talking to Trudy or Alice initially. Bob and Alice share a secret key K_{A-B} that is unknown to Trudy. Trudy wants Bob to authenticate her (Trudy) as Alice. Trudy is going to have Bob authenticate himself, and waits for Bob to start:

1. **Bob-to-Trudy: "I am Bob"** Commentary: Bob starts to authenticate himself. Bob's authentication of himself to the other side then stops for a few steps.
2. **Trudy-to-Bob: "I am Alice"** Commentary: Trudy starts to authenticate herself as Alice
3. **Bob-to-Trudy: "R"** Commentary: Bob responds to step 2 by sending a nonce in reply. Trudy does not yet know $K_{A-B}(R)$ so she can not yet reply.
4. **Trudy-to-Bob: "R"** Commentary: Trudy responds to step 1 now continuing Bob's authentication, picking as the nonce for Bob to encrypt, *the exact same value that Bob sent her to encrypt in Step 3.*
5. **Bob-to-Trudy: " $K_{A-B}(R)$ "** Bob completes his own authentication of himself to the other side by encrypting the nonce he was sent in step 4. Trudy now has $K_{A-B}(R)$. (Note: she does not have, nor need, K_{A-B})
6. **Trudy-to-Bob: " $K_{A-B}(R)$ "** Trudy completes her authentication, responding to the R that Bob sent in step 3 above with $K_{A-B}(R)$. Since Trudy has returned the properly encrypted nonce that Bob send in step 3, Bob thinks Trudy is Alice!

Problem 16

This wouldn't really solve the problem. Just as Bob thinks (incorrectly) that he is authenticating Alice in the first half of Figure 7.14, so too can Trudy fool Alice into thinking (incorrectly) that she is authenticating Bob. The root of the problem that neither Bob nor Alice can tell is the public key they are getting is indeed the public key of Alice of Bob.

Problem 17

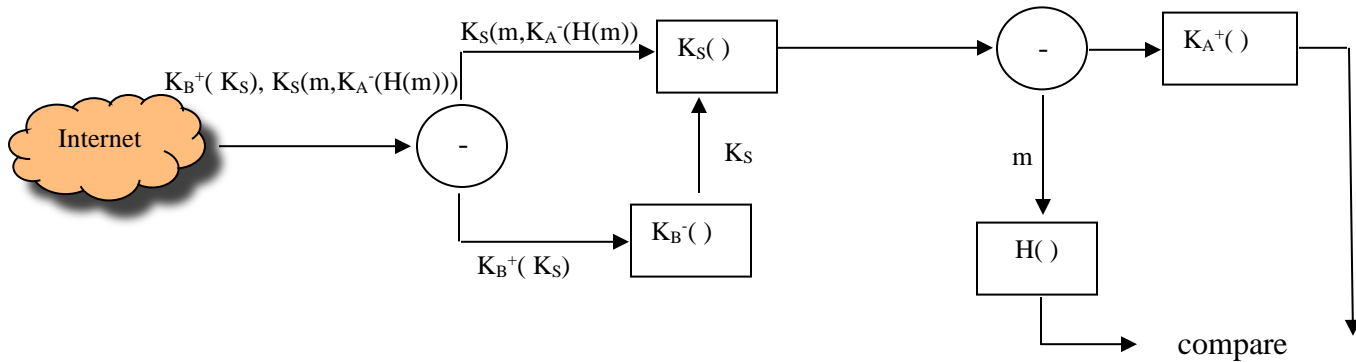

Figure: Operations performed by Bob for confidentiality, integrity, and authentication

Problem 18

- No, without a public-private key pair or a pre-shared secret, Bob cannot verify that Alice created the message.
- Yes, Alice simply encrypts the message with Bob's public key and sends the encrypted message to Bob.

Problem 19

- Client
- IP: 216.75.194.220, port: 443
- 283
- 3 SSL records
- Yes, it contains an encrypted master secret
- First byte: bc; Last byte: 29
- 6

Problem 20

Again we suppose that SSL does not provide sequence numbers. Suppose that Trudy, a woman-in-the-middle, deletes a TCP segment. So that Bob doesn't anything, Trudy needs to also adjust the sequence numbers in the subsequent packets sent from Alice to Bob, and the acknowledgment numbers sent from Bob to Alice. The result will be that Bob will, unknowingly, be missing a packet's worth of bytes in the byte stream.

Problem 21

No, the bogus packet will fail the integrity check (which uses a shared MAC key).

Problem 22

- a) F
- b) T
- c) T
- d) F

Problem 23

If Trudy does not bother to change the sequence number, R2 will detect the duplicate when checking the sequence number in the ESP header. If Trudy increments the sequence number, the packet will fail the integrity check at R2.

Problem 24

- a) Since $IV = 11$, the key stream is $111110100000 \dots\dots\dots$

Given, $m = 10100000$

Hence, $ICV = 1010 \text{ XOR } 0000 = 1010$

The three fields will be:

IV: 11

Encrypted message: $10100000 \text{ XOR } 11111010 = 01011010$

Encrypted ICV: $1010 \text{ XOR } 0000 = 1010$

- b) The receiver extracts the IV (11) and generates the key stream $111110100000 \dots\dots\dots$

XORs the encrypted message with the key stream to recover the original message:
 $01011010 \text{ XOR } 11111010 = 10100000$

XORs the encrypted ICV with the keystream to recover the original ICV:

$1010 \text{ XOR } 0000 = 1010$

The receiver then XORs the first 4 bits of recovered message with its last 4 bits:
 $1010 \text{ XOR } 0000 = 1010$ (which equals the recovered ICV)

- c) Since the ICV is calculated as the XOR of first 4 bits of message with last 4 bits of message, either the 1st bit or the 5th bit of the message has to be flipped for the received packet to pass the ICV check.
- d) For part (a), the encrypted message was 01011010
Flipping the 1st bit gives, 11011010
Trudy XORs this message with the keystream:
 $11011010 \text{ XOR } 11111010 = 00100000$

If Trudy flipped the first bit of the encrypted ICV, the ICV value received by the receiver is 0010

The receiver XORs this value with the keystream to get the ICV:

0010 XOR 0000 = 0010

The receiver now calculates the ICV from the recovered message:

0010 XOR 0000 = 0010 (which equals the recovered ICV and so the received packet passes the ICV check)

Problem 25

Filter Table:

Action	Source Address	Dest address	Protocol	Source port	Dest port	Flag bit	Check connection
allow	222.22/16	outside of 222.22/16	TCP	> 1023	23	any	
allow	outside of 222.22/16	222.22/16	TCP	23	> 1023	ACK	x
Allow	outside of 222.22/16	222.22.0.12	TCP	>1023	80	Any	
Allow	222.22.0.12	outside of 222.22/16	TCP	80	>1023	Any	
deny	All	all	all	all	all	All	

Connection Table:

Source address	Dest address	Source port	Dest port
222.22.1.7	37.96.87.123	12699	23
222.22.93.2	199.1.205.23	37654	23
222.22.65.143	203.77.240.43	48712	23

Problem 26

a)

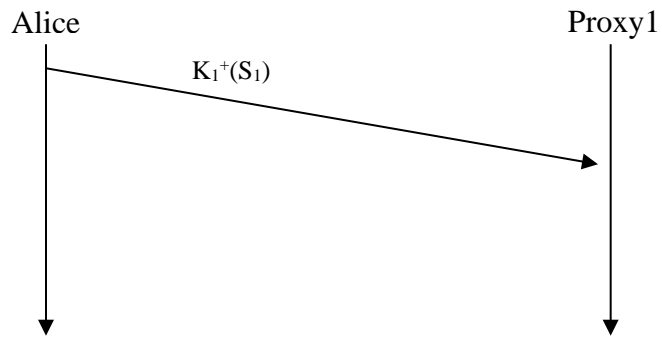

b)

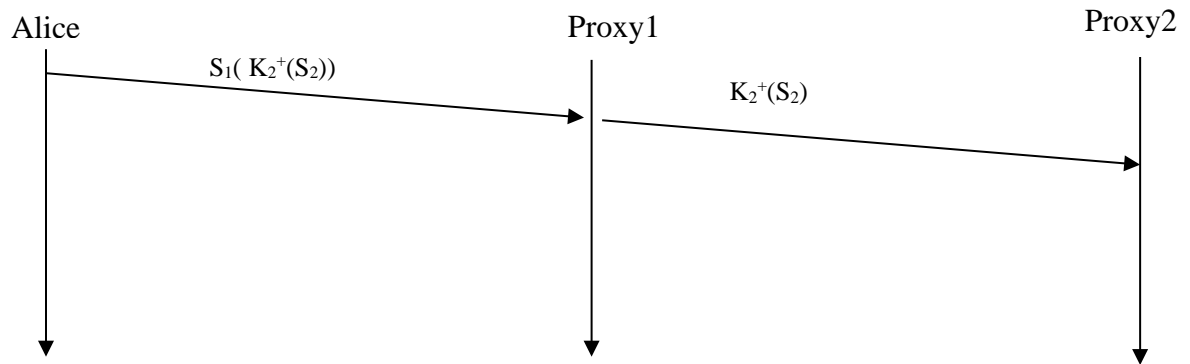

c)

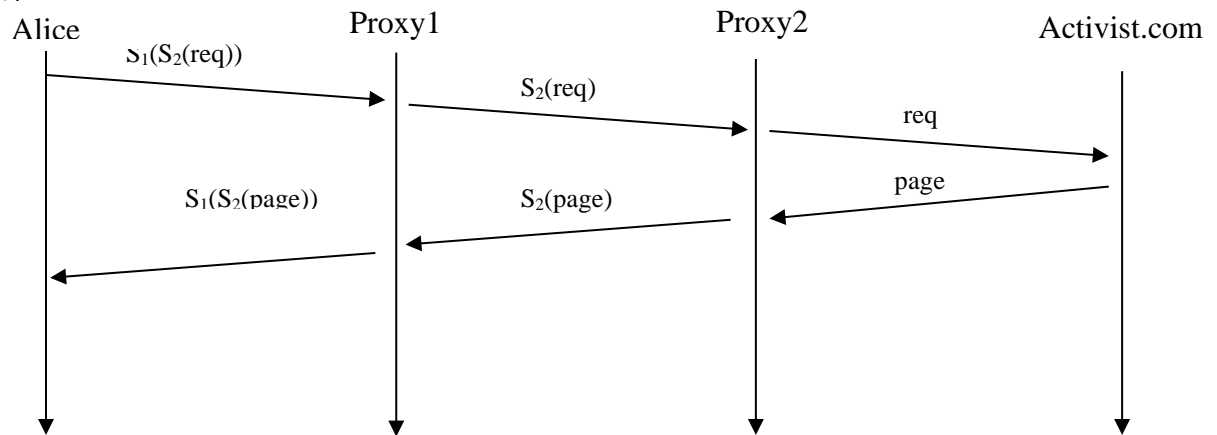

Chapter 9 Review Questions

1.

	Bit rate	Bytes transferred in 67 mins
Facebook Frank	40 kbps	20 Mbytes
Martha Music	200 kbps	100 Mbytes
Victor Video	4 Mbps	2 Gbytes

2. **Spatial Redundancy:** It is the redundancy within a given image. Intuitively, an image consists of mostly white space has a high degree of redundancy and can be efficiently compressed without significantly sacrificing image quality.

Temporal Redundancy reflects repetition from image to subsequent image. If, for example, an image and the subsequent image are exactly the same, there is no reason to re-encode the subsequent image; it is instead more efficient simply to indicate during encoding that the subsequent image is exactly the same. If the two images are very similar, it may be not efficient to indicate how the second image differs from the first, rather than re-encode the second image.

3. Quantizing a sample into 1024 levels means 10 bits per sample. The resulting rate of the PCM digital audio signal is 160 Kbps.

4. **Streaming stored audio/video:** In this class of applications, the underlying medium is prerecorded video, such as a movie, a television show, or a prerecorded sporting event. These prerecorded videos are played on servers, and users send requests to the servers to view the videos on demand. Many internet companies today provide streaming video, including YouTube, Netflix, and Hulu.

Conversational Voice- and Video-over-IP: Real-time conversational voice over the Internet is often referred to as Internet telephony, since, from the user's perspective, it is similar to the traditional circuit-switched telephone service. It is also commonly called Voice-over-IP (VOIP). Conversational video is similar except that it includes the video of the participants as well as their voices. Conversational voice and video are widely used in the Internet today, with the Internet companies like Skype and Google Talk boasting hundreds of millions of daily users.

Streaming Live Audio and Video: These applications allow users to receive a live radio or television transmission over the Internet. Today, thousands of radio and television stations around the world are broadcasting content over the internet.

5. **UDP Streaming:** With UDP streaming, the server transmits video at a rate that matches the client's video consumption rate by clocking out the video chunks over UDP at a steady rate.

HTTP Streaming: In HTTP streaming, the video is simply stored in an HTTP server as an ordinary file with a specific URL. When a user wants to see the video, the client establishes a TCP connection with the server and issues an HTTP GET request for that URL. The server then sends the video file, within an HTTP response message, as quickly as possible, that is, as quickly as TCP congestion control and flow control will allow.

Adaptive HTTP Streaming (DASH): In Dynamic Adaptive Streaming over HTTP, the video is encoded several different versions, with each version having a different bit rate and, correspondingly, a different quality level. The client dynamically requests the chunks of video segments of a few seconds in length from the different versions. When the amount of available bandwidth is high, the client naturally selects chunks from a high-rate version; and when the available bandwidth is low, it naturally selects from a low-rate version.

6. The three significant drawbacks of UDP Streaming are:
 1. Due to unpredictable and varying amount of available bandwidth between server and client, constant-rate UDP streaming can fail to provide continuous play out.
 2. It requires a media control server, such as an RTSP server, to process client-to-server interactivity requests and to track client state for each ongoing client session.
 3. Many firewalls are configured to block UDP traffic, preventing users behind these firewalls from receiving UDP video.
7. No. On the client side, the client application reads bytes from the TCP receive buffer and places the bytes in the client application buffer.
8. The initial buffering delay is $t_p = Q/x = 4$ seconds.
9. End-to-end delay is the time it takes a packet to travel across the network from source to destination. Delay jitter is the fluctuation of end-to-end delay from packet to the next packet.
10. A packet that arrives after its scheduled play out time cannot be played out. Therefore, from the perspective of the application, the packet has been lost.
11. First scheme: send a redundant encoded chunk after every n chunks; the redundant chunk is obtained by exclusive OR-ing the n original chunks. Second scheme: send a lower-resolution low-bit rate scheme along with the original stream. Interleaving does not increase the bandwidth requirements of a stream.
12. RTP streams in different sessions: different multicast addresses; RTP streams in the same session: SSRC field; RTP packets are distinguished from RTCP packets by using distinct port numbers.

13. The role of a SIP registrar is to keep track of the users and their corresponding IP addresses which they are currently using. Each SIP registrar keeps track of the users that belong to its domain. It also forwards INVITE messages (for users in its domain) to the IP address which the user is currently using. In this regard, its role is similar to that of an authoritative name server in DNS.

Chapter 9 Problems

Problem 1

- a) Client begins playout as soon as first block arrives at t_1 and video blocks are to be played out over the fixed amount of time, d . So it follows that second video block should be arrived before time $t_1 + d$ to be played at right time, third block at $t_1 + 2d$ and so on. We can see from figure that only blocks numbered 1,4,5,6 arrive at receiver before their playout times.
- b) Client begins playout at time $t_1 + d$ and video blocks are to be played out over the fixed amount of time, d . So it follows that second video block should be arrived before time $t_1 + 2d$ to be played at right time, third block at $t_1 + 3d$ and so on. We can see from figure that video blocks numbered from 1 to 6 except 7 arrive at receiver before their playout times.
- c) Maximum two video blocks are ever stored in the client buffer. Video blocks numbered 3 and 4 arrive before $t_1 + 3d$ and after $t_1 + 2d$, hence these two blocks are stored in the client buffer. Video block numbered 5 arrives before time $t_1 + 4d$ and after $t_1 + 3d$, which is stored in the client buffer along with already stored video block numbered 4.
- d) The smallest playout at the client should be $t_1 + 3d$ to ensure that every block has arrived in time.

Problem 2

- a) During a playout period, the buffer starts with Q bits and decreases at rate $r - x$. Thus, after $Q/(r - x)$ seconds after starting playback the buffer becomes empty. Thus, the continuous playout period is $Q/(r - x)$ seconds. Once the buffer becomes empty, it fills at rate x for Q/x seconds, at which time it has Q bits and playback begins. Therefore, the freezing period is Q/x seconds.
- b) Time until buffer has Q bits is Q/x seconds. Time to add additional $B - Q$ bits is $(B - Q)/(x - r)$ seconds. Thus the time until the application buffer becomes full is $\frac{Q}{x} + \frac{B-Q}{x-r}$ seconds.

Problem 3

- a) The server's average send rate is $H/2$.
- b) This part (b) is an odd question and will be removed from the next edition. After playing out the first frame, because $x(t) < r$, the next frame will arrive after the

scheduled playout time of the next frame. Thus playback will freeze after displaying the first frame.

- c) Let $q(t)$ denote the number of bits in the buffer at time t . Playout begins when $q(t) = Q$. Let's assume throughout this problem that $HT/2 \geq Q$, so that $q(t) = Q$ by the end of the first cycle for $x(t)$. We have

$$q(t) = \int_0^t \frac{H}{T} s ds = Ht^2/2T.$$

Therefore, $q(t) = Q$ when $t = \sqrt{2QT/H} = tp$.

- d) At time $t = T$, $q(t) = HT/2 = Q$, so that playout begins. If subsequently there is no freezing, we need $q(t + T) > 0$ for all $t \geq T$, we have

$$\begin{aligned} q(t + T) &= \frac{HT}{2} - rt + \int_0^t x(s) ds \\ &> \frac{H}{2}(T - t) + \int_0^t x(s) ds \end{aligned}$$

With $t = nT + \Delta$, with $0 < \Delta < T$, we have from above

$$\begin{aligned} q(t + T) &> \frac{H}{2}(T - nT - \Delta) + \frac{nHT}{2} + \frac{H\Delta^2}{2T} \\ &= \frac{H}{2}\left(T - \Delta + \frac{\Delta^2}{T}\right) \end{aligned}$$

Which is easily seen to be possible for all $0 < \Delta < T$.

- e) First consider the $[0, T]$. We have

$$q(t) = \frac{H}{2T}t^2 - r(t - tp) \quad \text{for } tp \leq t \leq T$$

$q(t)$ is minimized at $t = rT/H$. It can then be shown that $q(rT/H) \geq 0$ if and only if $tp \geq rT/2H$. Furthermore, if $tp = rT/2H$, proof can be extended to show $q(t) > 0$ for all $t \geq T$ thus, $tp < rT/2H$ and $Q = r^2T/8H$.

- f) This is a very challenging problem. Assuming that B is reached before time T , then t is solution to $\frac{H}{2T}t^2 - r(t - \sqrt{2QT/H}) = B$.

Problem 4

- a) Buffer grows at rate $x - r$. At time E , $(x - r)*E$ bits are in buffer and are wasted.
- b) Let S be the time when the server has transmitted the entire video. If $S > E$, buffer grows at rate $x - r$ until time E , so the waste is again $(x - r)*E$. If $S < E$, then at time E there are $T - E$ seconds of video still to be played in buffer. So the waste is $r*(T - E)$.

Problem 5

- a) $N*N = N^2$.
b) $N+N = 2N$

Problem 6

- a) $160 + h$ bytes are sent every 20 msec. Thus the transmission rate is
$$\frac{(160 + h) \cdot 8}{20} Kbps = (64 + .4h) Kbps$$
- b)
IP header: 20 bytes
UDP header: 8 bytes
RTP header: 12 bytes
- c) $h=40$ bytes (a 25% increase in the transmission rate!)

Problem 7

- a) Denote $d^{(n)}$ for the estimate after the n th sample.

$$d^{(1)} = r_4 - t_4$$

$$d^{(2)} = u(r_3 - t_3) + (1 - u)(r_4 - t_4)$$

$$d^{(3)} = u(r_2 - t_2) + (1 - u)[u(r_3 - t_3) + (1 - u)(r_4 - t_4)]$$

$$= u(r_2 - t_2) + (1 - u)u(r_3 - t_3) + (1 - u)^2(r_4 - t_4)$$

$$d^{(4)} = u(r_1 - t_1) + (1 - u)d^{(3)}$$

$$= u(r_1 - t_1) + (1 - u)u(r_2 - t_2) + (1 - u)^2u(r_3 - t_3) + (1 - u)^3(r_4 - t_4)$$

- b)

$$d^{(n)} = u \sum_{j=1}^{n-1} (1 - u)^j (r_j - t_j) + (1 - u)^n (r_n - t_n)$$

c)

$$d^{(\infty)} = \frac{u}{1-u} \sum_{j=1}^{\infty} (1-u)^j (r_j - t_j)$$

$$= \frac{1}{9} \sum_{j=1}^{\infty} .9^j (r_j - t_j)$$

The weight given to past samples decays exponentially.

Problem 8

a) Denote $v^{(n)}$ for the estimate after the n th sample. Let $\Delta_j = r_j - t_j$.

$$v^{(1)} = | \Delta_4 - d^{(1)} | \quad (=0)$$

$$v^{(2)} = u | \Delta_3 - d^{(2)} | + (1-u) | \Delta_4 - d^{(1)} |$$

$$v^{(3)} = u | \Delta_2 - d^{(3)} | + (1-u)v^{(2)}$$

$$= u | \Delta_2 - d^{(3)} | + u(1-u) | \Delta_3 - d^{(2)} | + (1-u)^2 | \Delta_4 - d^{(1)} |$$

$$v^{(4)} = u | \Delta_1 - d^{(4)} | + (1-u)v^{(3)}$$

$$= u | \Delta_1 - d^{(4)} | + (1-u)u | \Delta_2 - d^{(3)} | + u(1-u)^2 | \Delta_3 - d^{(2)} |$$

$$+ (1-u)^3 | \Delta_4 - d^{(1)} |$$

$$= u [| \Delta_1 - d^{(4)} | + (1-u) | \Delta_2 - d^{(3)} | + (1-u)^2 | \Delta_3 - d^{(2)} |]$$

$$+ (1-u)^3 | \Delta_4 - d^{(1)} |$$

b)

$$v^{(n)} = u \sum_{j=1}^{n-1} (1-u)^{j-1} | \Delta_j - d^{(n-j+1)} | + (1-u)^n | \Delta_n - d^{(1)} |$$

Problem 9

a) $r_1 - t_1 + r_2 - t_2 + \dots + r_{n-1} - t_{n-1} = (n-1)dn-1$

Substituting this into the expression for d_n gives

$$d_n = \frac{n-1}{n}d_{n-1} + \frac{r_n - t_n}{n}$$

- b) The delay estimate in part (a) is an average of the delays. It gives equal weight to recent delays and to “old” delays. The delay estimate in Section 6.3 gives more weight to recent delays; delays in the distant past have relatively little impact on the estimate.

Problem 10

The two procedures are very similar. They both use the same formula, thereby resulting in exponentially decreasing weights for past samples.

One difference is that for estimating average RTT, the time when the data is sent and when the acknowledgement is received is recorded on the same machine. For the delay estimate, the two values are recorded on different machines. Thus the sample delay can actually be negative.

Problem 11

- a) The delay of packet 2 is 7 slots. The delay of packet 3 is 9 slots. The delay of packet 4 is 8 slots. The delay of packet 5 is 7 slots. The delay of packet 6 is 9 slots. The delay of packet 7 is 8 slots. The delay of packet 8 is > 8 slots.
- b) Packets 3, 4, 6, 7, and 8 will not be received in time for their playout if playout begins at $t=8$.
- c) Packets 3 and 6 will not be received in time for their playout if playout begins at $t=9$.
- d) No packets will arrive after their playout time if playout time begins at $t=10$.

Problem 12

The answers to parts a and b are in the table below:

Packet Number	$r_i - t_i$	d_i	v_i
1	7	7	0
2	8	7.10	0.09
3	8	7.19	0.162
4	7	7.17	0.163
5	9	7.35	0.311
6	9	7.52	0.428

7	8	7.57	0.429
8	8	7.61	0.425

Problem 13

- Both schemes require 25% more bandwidth. The first scheme has a playback delay of 5 packets. The second scheme has a delay of 2 packets.
- The first scheme will be able to reconstruct the original high-quality audio encoding. The second scheme will use the low quality audio encoding for the lost packets and will therefore have lower overall quality.
- For the first scheme, many of the original packets will be lost and audio quality will be very poor. For the second scheme, every audio chunk will be available at the receiver, although only the low quality version will be available for every other chunk. Audio quality will be acceptable.

Problem 14

- Each of the other $N - 1$ participants sends a single audio stream of rate r bps to the initiator. The initiator combines this stream with its own outgoing stream to create a stream of rate r . It then sends a copy of the combined stream to each of the $N - 1$ other participants. The call initiator therefore sends at a total rate of $(N-1)r$ bps, and the total rate aggregated over all participants is $2(N-1)r$ bps.
- As before, each of the other $N - 1$ participants sends a single video stream of rate r bps to the initiator. But because the streams are now video, the initiator can no longer combine them into a single stream. The initiator instead must send each stream it receives to $N - 2$ participants. The call initiator therefore sends at a total rate of $(N-1)*(N-1)r$ bps, and the total rate aggregated over all participants is $(N-1)r + (N-1)*(N-1)r = N(N-1)r$ bps.
- $N*(N-1)r$ bps

Problem 15

- As discussed in Chapter 2, UDP sockets are identified by the two-tuple consisting of destination IP address and destination port number. So the two packets will indeed pass through the same socket.
- Yes, Alice only needs one socket. Bob and Claire will choose different SSRC's, so Alice will be able distinguish between the two streams. Another question we could have asked is: How does Alice's software know which stream (i.e. SSRC) belongs to Bob and which stream belongs to Alice? Indeed, Alice's software may want to display the sender's name when the sender is talking. Alice's software gets the SSRC to name mapping from the RTCP source description reports.

Problem 16

- a) True
- b) True
- c) No, RTP streams can be sent to/from any port number. See the SIP example in Section 6.4.3
- d) No, typically they are assigned different SSRC values.
- e) True
- f) False, she is indicating that she wishes to *receive* GSM audio
- g) False, she is indicating that she wishes to *receive* audio on port 48753
- h) True, 5060 for both source and destination port numbers
- i) True
- j) False, this is a requirement of H.323 and not SIP.

Problem 17

Time Slot	Packets in the queue	Number of tokens in bucket
0	1, 2, 3	2
1	3, 4	1
2	4,5	1
3	5,6	1
4	6	1
5	-	1
6	7, 8	2
7	9, 10	1
8	10	1

Time Slot	Packets in output buffer
0	1, 2
1	3
2	4
3	5
4	6
5	-
6	7, 8
7	9
8	10

Problem 18

Time Slot	Packets in the queue	Number of tokens in bucket
0	1, 2, 3	2
1	3, 4	2
2	5	2
3	6	2
4	-	2
5	-	2
6	7, 8	2
7	9, 10	2
8	-	2

Time Slot	Packets in output buffer
0	1, 2
1	3, 4
2	5
3	6
4	-
5	-
6	7, 8
7	9, 10
8	-

Problem 19

No. The answer still remains the same as in Problem 21.

Problem 20

See figure below. For the second leaky bucket, $r = p, b = 1$.

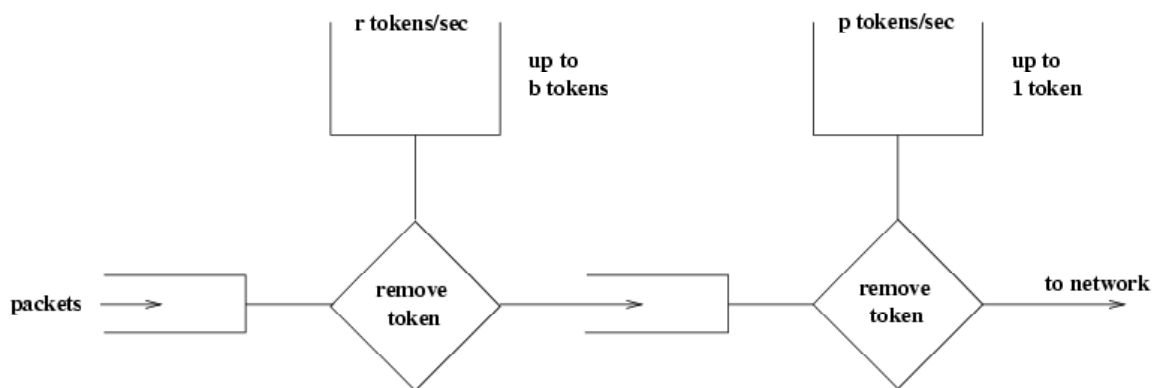

Figure: Solution to problem 26

Problem 21

No.

Problem 22

Let τ be a time at which flow 1 traffic starts to accumulate in the queue. We refer to τ as the beginning of a flow-1 busy period. Let $t > \tau$ be another time in the same flow-1 busy period. Let $T_1(\tau, t)$ be the amount of flow-1 traffic transmitted in the interval $[\tau, t]$. Clearly,

$$T_1(\tau, t) \geq \frac{W_1}{\sum W_j} R(t - \tau)$$

Let $Q_1(t)$ be the amount of flow-1 traffic in the queue at time t . Clearly,

$$Q_1(t) = b_1 + r_1(t - \tau) - T_1(\tau, t)$$

$$\leq b_1 + r_1(t - \tau) + \frac{W_1}{\sum W_j} R(t - \tau)$$

$$= b_1 + (t - \tau) \left[r_1 - \frac{W_1}{\sum W_j} R \right]$$

Since $r_1 < \frac{W_1}{\sum W_j} R$, $Q_1(t) \leq b_1$. Thus the maximum amount of flow-1 traffic in the queue

is b_1 . The minimal rate at which this traffic is served is $\frac{W_1 R}{\sum W_j}$.

Thus, the maximum delay for a flow-1 bit is

$$\frac{b_1}{W_1 R / \sum W_j} = d_{\max}.$$