

**digital**

**USER GUIDE**  
**VT125**

EK-VT125-UG-001



EK-VT125-UG-001

VT125 USER GUIDE

Produced by Educational Services  
of  
Digital Equipment Corporation

Copyright © 1981 by Digital Equipment Corporation

All Rights Reserved

The reproduction of this material, in part or whole, is strictly prohibited. For copy information, contact the Educational Services Department, Digital Equipment Corporation, Maynard, Massachusetts 01754.

The information in this document is subject to change without notice. Digital Equipment Corporation assumes no responsibility for any errors that may appear in this manual.

Printed in U.S.A.

The following are trademarks of Digital Equipment Corporation, Maynard, Massachusetts.

DEC	DECnet	OMNIBUS
DECUS	DECsystem-10	OS/8
DIGITAL	DECSYSTEM-20	PDT
Digital Logo	DECwriter	RSTS
PDP	DIBOL	RSX
UNIBUS	EduSystem	VMS
VAX	IAS	VT
	MASSBUS	

## CONTENTS

### INTRODUCTION

### CHAPTER 1 OPERATING INFORMATION

General .....	1-1
Terminal Operation .....	1-1
Controls and Indicators .....	1-1
Monitor Controls .....	1-1
AC Voltage Selection Switch .....	1-1
Keyboard Controls .....	1-4
Standard Keys .....	1-4
Auxiliary Keypad Keys .....	1-6
Function Keys .....	1-6
Auxiliary Keypad .....	1-8
SET-UP Keys .....	1-8
Keyboard Indicators .....	1-11
ON LINE Indicator .....	1-11
LOCAL Indicator .....	1-11
KBD LOCKED Indicator .....	1-11
L1 - L4 .....	1-13
Audible Indicators .....	1-13
Keyclick .....	1-13
Series of Long Tones .....	1-13

### CHAPTER 2 SET-UP FEATURES

General .....	2-1
SET-UP Features .....	2-1
Operator Preference Features .....	2-2
Communication Compatibility Features .....	2-2
Installation Features .....	2-2
Feature Selection .....	2-2
Entering and Exiting SET-UP .....	2-5
Feature Memories .....	2-5
Operating Memory .....	2-5
User Permanent Memory .....	2-7
Store .....	2-7
Recall .....	2-7
Reset .....	2-8
SET-UP Default Memory .....	2-8

SET-UP Feature Definitions .....	2-8
General SET-UP Features .....	2-8
ON LINE/LOCAL .....	2-8
Screen Brightness .....	2-10
SET-UP A Features .....	2-10
Characters Per Line .....	2-10
Tabs .....	2-12
SET-UP B Features .....	2-13
Scroll .....	2-13
Screen Background .....	2-15
Cursor .....	2-15
Margin Bell .....	2-15
Keyclick .....	2-15
ANSI/VT52 .....	2-15
AUTO XON/XOFF .....	2-17
U.S./U.K. Character Set Switch .....	2-17
Auto Wrap .....	2-17
Line Feed/New Line .....	2-17
Interlace .....	2-17
Parity Sense .....	2-18
Parity .....	2-18
Bits Per Character .....	2-19
Power .....	2-19
AUX Port Bits Per Character .....	2-19
AUX Port Speed .....	2-19
Transmit Speed .....	2-19
Receive Speed .....	2-20
Answerback Message .....	2-20

### CHAPTER 3 TRANSMITTED CHARACTERS

General .....	3-1
Standard Keys .....	3-1
Function Keys .....	3-1
Break Key .....	3-1
↑ ↓ ← → Cursor Control Keys .....	3-1
Control Character Keys .....	3-3
Auxiliary Keypad Keys .....	3-5

### CHAPTER 4 RECEIVED CHARACTER PROCESSING

General .....	4-1
Errors .....	4-1
ASCII Table and Received Characters .....	4-2
Displayable Characters .....	4-2
Control Characters Received .....	4-4
Sequences .....	4-4
ANSI Sequences .....	4-4
1 Set-Up Feature and Mode Selection .....	4-4
Set Mode Command - SM .....	4-7
Reset Mode Command - RM .....	4-7
ANSI Specified Modes .....	4-7
DEC Private Modes .....	4-7
ANSI/VT52 Mode (DEC Private - DECANM .....	4-8
Auto Repeat Mode (DEC Private) - DECARM .....	4-8

Autowrap Mode (DEC Private) - DECAWM .....	4-10
Column Mode (DEC Private) - DECCOLM .....	4-10
Cursor Keys Mode (DEC Private) - DECCKM .....	4-11
Linefeed/New Line Mode - LNM .....	4-11
Keypad Application Mode (DEC Private) - DECKPAM .....	4-13
Keypad Numeric Mode (DEC Private) - DECKPNM .....	4-13
Origin Mode (DEC Private) - DECOM .....	4-13
Screen Mode (DEC Private) - DECSCNM .....	4-14
Scrolling Mode (DEC Private) - DECSCLM .....	4-14
2 Character Sets and Selection .....	4-15
Select Character Sets - SCS .....	4-15
Select Graphic Rendition - SGR .....	4-20
3 Scrolling .....	4-21
Scrolling Region .....	4-21
Set Top and Bottom Margins (DEC Private) - DECSTBM .....	4-21
4 Cursor Positioning .....	4-21
5 Tabs .....	4-21
Horizontal Tabulation Set - HTS .....	4-25
Tabulation Clear - TBC .....	4-25
6 Line Attributes .....	4-25
Double Height Line (DEC Private) - DECDHL .....	4-25
Double-Width Line (DEC Private) - DECDWL .....	4-25
Single-width Line (DEC Private) - DECSWL .....	4-27
7 Erasing .....	4-28
Erase In Display - ED .....	4-28
Erase In Line - EL .....	4-28
8 VT125 Communication and Graphics Protocol Controls .....	4-30
Device Control String (Introducer) - DCS .....	4-30
Device Control String Parameters .....	4-30
9 Reports .....	4-33
Device Attributes - DA .....	4-34
Identify Terminal (DEC Private) - DECID .....	4-35
Device Status Report - DSR .....	4-35
10 Reset .....	4-35
11 Tests and Adjustments .....	4-36
Invoke Confidence Test - DECTST .....	4-36
12 Indicators .....	4-36
Keyboard Indicators .....	4-36
VT52 Compatible Sequences .....	4-39
SET-UP Features and Mode Selection .....	4-39
13 VT52 Modes .....	4-39
14 VT52 Characters Sets and Selection .....	4-40
15 VT52 Cursor Positioning .....	4-41
16 VT52 Erasing .....	4-43
17 VT52 Reports .....	4-43

## CHAPTER 5 ReGIS GRAPHIC PROGRAMMING

Introduction .....	5-1
Definitions .....	5-1
ReGIS SYNTAX .....	5-2
Introduction .....	5-2
ReGIS Single Character Commands .....	5-2
Parentheses, Brackets, Pixel Vectors, and Quotes .....	5-2
Commas and Spaces .....	5-3

Control Characters .....	5-3
Order of Performance .....	5-4
Numeric Values .....	5-4
Position .....	5-5
Coordinates .....	5-5
Position Command .....	5-5
Absolute Position .....	5-5
Relative Position .....	5-6
Combining Absolute and Relative Positions .....	5-6
Null Position .....	5-6
Pixel Vectors .....	5-6
Temporary Pixel Vector Multiplier .....	5-6
Begin a Bounded Sequence of Coordinates .....	5-8
Start an Unbounded Sequence of Coordinates .....	5-8
End a Sequence of Coordinates .....	5-8
Writing Commands .....	5-9
General .....	5-9
Pixels .....	5-9
Odd-Y Simulation .....	5-9
Vector Command .....	5-10
Dot at Current Position .....	5-10
Vector from Current Position to Specified Position .....	5-10
Pixel Vectors .....	5-10
Bounded Sequence of Positions .....	5-12
Unbounded Sequence of Positions .....	5-12
Temporary Writing Controls .....	5-13
Curves.....	5-13
Circles .....	5-14
Circle with Center at Current Position .....	5-14
Circle with Center at Specified Position .....	5-14
Arcs .....	5-14
Arc with Center at Current Position .....	5-14
Arc with Center at Specified Position .....	5-17
Open and Closed Curves .....	5-17
Interpolation of Curves .....	5-17
Unbounded (Open) Curves .....	5-17
Bounded (Closed) Curves .....	5-20
Temporary Curve Writing Controls .....	5-20
Text .....	5-22
General .....	5-22
Text Commands .....	5-23
Text .....	5-23
Text Character Cell Size .....	5-23
Text Character Height Multiplier .....	5-26
Text Character Spacing .....	5-26
Text Pixel Vector Spacing .....	5-26
Text Character Cell Size .....	5-27
Text Pixel Multiplier .....	5-27
Text String and Character Tilt Direction .....	5-29
Text Italic Tilt .....	5-31
Select Text Character Set .....	5-31
Store and Restore Options .....	5-33
Temporary Writing Controls .....	5-33



Writing Controls .....	5-33
Initial Writing Control Defaults .....	5-33
Writing Modes .....	5-34
Complement Writing .....	5-35
Erase Writing .....	5-36
Replace Writing .....	5-37
Overlay Writing .....	5-38
Foreground Planes .....	5-38
Foreground Intensity and Color .....	5-41
Pixel Vector Length Multiplier .....	5-42
Negative Writing .....	5-42
Shading .....	5-42
Shading On or Off .....	5-43
Shading Character .....	5-43
Shading Reference Line .....	5-43
Patterns .....	5-44
Select Standard Pattern .....	5-46
Specify Binary Pattern .....	5-46
Set Pattern Multiplier .....	5-47
custom Writing Control Definition .....	5-47
Screen Controls .....	5-51
Initial Screen Control Defaults .....	5-51
Screen Scrolling .....	5-51
Screen Display Addressing Definition .....	5-53
Screen Erase .....	5-56
Screen Hard Copy Output .....	5-56
Screen Background Definition .....	5-57
Screen Output Map Definition .....	5-58
Screen Scale .....	5-61
Screen Time Delay .....	5-61
Macrographs .....	5-63
Clear All Macrographs .....	5-64
Macrograph Definition .....	5-64
Macrograph Invocation .....	5-65
Character Cell Controls .....	5-65
Select Character Set for Loading .....	5-65
Associate Name with Current Character Set .....	5-66
Load Character Cell .....	5-66
Reports .....	5-68
Report Character Set Selected for Loading .....	5-68
Report Contents of a Macrograph .....	5-69
Report Use of Macrograph Storage .....	5-69
Report Cursor Position .....	5-69

## CHAPTER 6 VT125 EMULATION

Introduction .....	6-1
Entering the Graph Drawing Mode .....	6-2
Definitions and Limitations .....	6-2
Selecting the Graph Drawing Field .....	6-5
Selecting Desired Display .....	6-5
Loading Control Register 0 .....	6-8
Enabling Graphs and Histograms .....	6-13
Enabling Strip Charts and Shade Lines .....	6-13
Loading Control Register 1 .....	6-13

Enabling Graph Markers, Vertical Lines, and Horizontal Lines .....	6-14
Forming Graph Drawing Data Characters .....	6-14
Selecting Upper and Lower Data Characters .....	6-16
Load Data Sequences .....	6-18
Frequent Data Entry Errors .....	6-18
Loading the Shade Line .....	6-19
Loading Graph Memories .....	6-19
Histogram Data .....	6-22
Loading Graph Marker Memory .....	6-22
Displaying Vertical Lines .....	6-22
Displaying Horizontal Lines .....	6-24
Load the Starting X-Coordinate .....	6-25
Entering Strip Chart Data .....	6-25
Single Strip Chart Data .....	6-26
Dual Strip Chart Data .....	6-27

## CHAPTER 7 VT125 COMMUNICATIONS

General .....	7-1
Connecting to the Computer Port .....	7-1
Connecting to the Auxiliary Port .....	7-1
Serial Character Format .....	7-1
Break Signal .....	7-4
Full Duplex Communication .....	7-4
Electronic Industry Association (EIA) Interface .....	7-4
SET-UP and Communications .....	7-7
Control Functions .....	7-7
Communication Cables .....	7-8
Block Diagrams .....	7-8
Input Buffer Overflow Prevention .....	7-13
XON and XOFF Control Characters .....	7-16
Effects of Reset and Tests .....	7-17
Transmit Buffers .....	7-17

## CHAPTER 8 INSTALLATION

General .....	8-1
Site Considerations .....	8-1
Inspection .....	8-3
Installation Procedure .....	8-3
Power Up and Checkout Procedure .....	8-7

## CHAPTER 9 OPERATOR MAINTENANCE AND TROUBLESHOOTING

General .....	9-1
Maintenance .....	9-1
What To Do in the Event of a Problem .....	9-1
VT125 Self Tests .....	9-2
Power Up Self Test .....	9-2
Computer Data Port Loopback Self Test .....	9-4
Auxiliary Port Loopback Test .....	9-6
Display Test .....	9-6
Video Bit Map Memory Test .....	9-9
VT125 Self Test Error Codes .....	9-9

## CHAPTER 10 OPTIONS

General .....	10-1
Description .....	10-1
20 mA Option Installation .....	10-3
Computer Data Port Loopback Self Test .....	10-3
Advanced Video Option .....	10-7
Description .....	10-7
Installation .....	10-9
Advanced Video Option Test .....	10-11
VT1XX-CB or -CL Installation into VT100 and VT105 .....	10-11
Tools Needed .....	10-13
Installation Procedure .....	10-13

## CHAPTER 11 ACCESSORIES AND SUPPLIES INFORMATION

General .....	11-1
Accessories and Supplies .....	11-1
Ordering Information .....	11-6

## APPENDIX A VT125 SPECIFICATIONS

## APPENDIX B SET-UP B SUMMARY

## APPENDIX C TRANSMITTED CHARACTER SUMMARY

## APPENDIX D PROGRAMMING SUMMARY

## APPENDIX E ANSI CODE EXTENSION TECHNIQUES

## APPENDIX F CREATING COMPATIBLE ReGIS

## APPENDIX G THE HLS COLOR SYSTEM IN THE VT125

## APPENDIX H ReGIS COMMAND LISTINGS

## ANSI GLOSSARY

## OTHER TERMINALS

## Figure

1-1	VT125 Graphics Terminal .....	1-2
1-2	Monitor Controls and Connector Locations .....	1-2
1-3	Standard Keys .....	1-5
1-4	Function Keys .....	1-7
1-5	SET-UP Keys .....	1-9
1-6	Keyboard Indicators .....	1-12
2-1	SET-UP Displays .....	2-4
2-2	SET-UP Feature Memories .....	2-6
2-3	SET-UP Default Feature Selections .....	2-9
2-4	80- and 132-Column Displays .....	2-11
2-5	SET-UP B Summary .....	2-14
2-6	Screen Background .....	2-16

2-7	Answerback Message .....	2-22
3-1	Standard Key Codes .....	3-2
3-2	Function Keys .....	3-2
3-3	Function Key Control Codes .....	3-4
4-1	VT125 ANSI Mode Display Control Functions .....	4-45
5-1	Pixel Vector .....	5-7
5-2	Pixel Vector .....	5-11
5-3	Nested (B) and (E) Commands .....	5-11
5-4	Circle with Center at Current Position .....	5-15
5-5	Circle with Center at Specified Position .....	5-15
5-6	Arc with Center at Current Position .....	5-16
5-7	Arc with Center at Specified Position .....	5-18
5-8	Unbounded (Open) Curves .....	5-19
5-9	Bounded (Closed) Curves .....	5-21
5-10	Copying Pixel 1 to Pixel 9 .....	5-25
5-11	Text Character Spacing .....	5-25
5-12	Pixel Vectors .....	5-28
5-13	Text Character Cell Size .....	5-28
5-14	360 Degree Compass .....	5-30
5-15	Text String and Character Tilt Direction .....	5-30
5-16	Text Italic Tilt .....	5-32
5-17	Complement Writing .....	5-35
5-18	Erase Writing .....	5-36
5-19	Replace Writing .....	5-37
5-20	Overlay Writing .....	5-38
5-21	Foreground Planes and the Output Map .....	5-40
5-22	Selecting a Shading Reference Line .....	5-45
5-23	Pattern Memory and Multiplier .....	5-48
5-24	Custom Writing Control Command .....	5-48
5-25	Scrolling the Display Window .....	5-52
5-26	Axis Address Transformation .....	5-54
5-27	VT125 Addressing Range .....	5-54
5-28	Colors in the VT125 .....	5-59
5-29	Default Output Map .....	5-62
5-30	Sample Output Map Definitions .....	5-62
5-31	Sample Character Cells .....	5-67
6-1	Graph with Graph Markers .....	6-3
6-2	Histogram Display .....	6-3
6-3	Example of a Grid Display .....	6-4
6-4	Strip Chart Display .....	6-6
6-5	Rectangular Graph Drawing Field .....	6-6
6-6	Square Graph Drawing Field .....	6-7
6-7	Histogram Without Shade Line (Baseline) Enabled .....	6-21
6-8	Graph with Shade Line (Baseline) Enabled .....	6-21
7-1	Connecting to the Computer .....	7-1
7-2	Serial Character Format .....	7-2
7-3	EIA Connectors and Pin Locations .....	7-5
7-4	Cable Summary .....	7-9
7-5	VT125 General Block Diagram .....	7-10
7-6	VT125 Data Paths .....	7-10
7-7	VT125 as Text-Only Terminal .....	7-12
7-8	VT125 in a Graphics Protocol .....	7-14
7-9	VT125 in ReGIS Graphics with Commands on Screen .....	7-14

7-10	VT125 Printing from Screen .....	7-15
7-11	VT125 Printing from Computer .....	7-15
8-1	VT125 Terminal Dimensions .....	8-2
8-2	Monitor Controls and Connector Location .....	8-4
8-3	Interface Cable Ground Connection .....	8-6
9-1	EIA Loopback Connector .....	9-8
10-1	20 mA Connector and Pin Locations .....	10-2
10-2	20 mA Current Loop Option Board Installation .....	10-4
10-3	20 mA Current Loop Option Switches .....	10-5
10-4	20 mA Current Loop Option Cable Position .....	10-6
10-5	20 mA Loopback Connector .....	10-8
10-6	Advanced Video Option Location and Installation .....	10-10
10-7	Check ROM Numbers .....	10-12
10-8	Top Cover Removal .....	10-14
10-9	Expansion Backplane Installation .....	10-15
10-10	Installing Ground Clips .....	10-17
10-11	16 Pin Flat Cable on Terminal Controller .....	10-18
10-12	STP Paddleboard Installation .....	10-19
10-13	24 Pin Flat Cable on STP Board .....	10-20
10-14	Graphic Cable Connections .....	10-22
10-15	Paddleboard Switches - Variations .....	10-23
10-16	Connecting EIA Line Filter and Ground Wires .....	10-24
10-17	RF Shield Installed .....	10-25
11-1	Accessories and Supplies Group .....	11-2
A-1	Composite Video Output .....	A-4
B-1	SET-UP B Display .....	B-3
B-2	SET-UP B Summary .....	B-4
C-1	Standard Key Codes .....	C-1
C-2	Function Key Control Codes .....	C-2
E-1	.....	E-2
E-2	8-Bit ASCII Chart .....	E-8
G-1	HLS Double Cone Color Model .....	G-2

**Table**

2-1	SET-UP Feature Types .....	2-1
2-2	SET-UP Features the Computer Can Change .....	2-3
2-3	Line Feed/New Line Feature Summary .....	2-18
3-1	Cursor Control Key Codes .....	3-3
3-2	Comparison of Control Character Generation .....	3-3
3-3	Auxiliary Keypad Codes .....	3-5
4-1	ASCII Table .....	4-3
4-2	Control Characters Recognized by VT125 .....	4-5
4-3	SET-UP Features and Terminal Modes .....	4-6
4-4	DEC Private Modes .....	4-8
4-5	Permanently Selected Modes .....	4-9
4-6	Cursor Control Key Codes .....	4-10
4-7	Linefeed/Newline Mode .....	4-11
4-8	ANSI Mode Auxiliary Keypad Codes .....	4-13
4-9	U.K. Character Set .....	4-16
4-10	U.S. Character Set .....	4-17
4-11	Special Character and Line Drawing Character Set .....	4-18

4-12	Cursor Positioning Commands .....	4-23
4-13	VT100 Self-Tests .....	4-37
4-14	VT125 Self-Tests .....	4-38
4-15	VT52 Mode Auxiliary Keypad Codes .....	4-40
4-16	Special Character and Line Drawing Set and Graphics Mode Comparison .....	4-42
4-17	VT52 Cursor Positioning .....	4-44
5-1	VT125 Graphics Protocols .....	5-2
5-2	Position Command Summary .....	5-9
5-3	Vector Command Summary .....	5-13
5-4	Curve Command Summary .....	5-20
5-5	Text Size Command Equivalents .....	5-24
5-6	Italic Tilt Values .....	5-31
5-7	Text Command Summary .....	5-34
5-8	Complementing the Foreground .....	5-35
5-9	Standard Patterns in the VT125 .....	5-46
5-10	2, 4, and 8 Bit Binary Pattern Repeats .....	5-46
5-11	3, 5, 6, and 7 Bit Binary Pattern Repeats .....	5-47
5-12	Writing Controls Summary .....	5-50
5-13	Wrap Address Formulas .....	5-55
5-14	Integer or RGB Colors in the VT125 .....	5-58
5-15	Default Output Map Values .....	5-60
5-16	Screen Controls Summary .....	5-63
5-17	Macrograph Command Summary .....	5-65
5-18	Character Set Definition Format .....	5-68
5-19	Character Cell Control Summary .....	5-68
5-20	Report Command Summary .....	5-70
6-1	Comparison of Graph Drawing Formats .....	6-8
6-2	Load Enable Register 0 Command .....	6-9
6-3	Examples of Selecting Graphs or Histogram .....	6-11
6-4	Examples of Selecting Shaded Graphs with Shade Lines (Baselines) and Strip Charts .....	6-11
6-5	Graph Drawing Characters .....	6-12
6-6	Load Enable Register 1 Command .....	6-13
6-7	Examples of Selecting Graph Markers, Horizontal Lines, and Vertical Lines .....	6-15
6-8	Graph Drawing Data Characters .....	6-17
6-9	Load Data Sequences .....	6-18
6-10	Loading Shade Line Position .....	6-19
6-11	Loading Graph Data .....	6-20
6-12	Load Graph Marker Memory .....	6-23
6-13	Load Vertical Line Coordinate .....	6-24
6-14	Load Horizontal Line Coordinates .....	6-25
6-15	Load Starting X Coordinate .....	6-26
7-1	Computer Port EIA Connector Signals .....	7-3
7-2	Auxiliary Port IEA Connector Signals .....	7-6
7-3	Interface Cables .....	7-11
8-1	Site Considerations .....	8-3
9-1	Problem Checklist .....	9-3
9-2	Display Test Indications .....	9-7
9-3	Displayed Error Codes .....	9-10
B-1	SET-UP Feature Types .....	B-2
C-1	Control Codes Generated .....	C-3

## INTRODUCTION

### PRODUCT INTRODUCTION

The VT125 is a graphics display terminal that combines a bit map architecture with the alphanumeric capability of the VT100 video terminal. The VT125 is a smart terminal that directly executes Digital's general purpose graphics descriptor, ReGIS (Remote Graphics Instruction Set). ReGIS lets you create and store pictures as ASCII text and efficiently send those pictures to remote displays. The VT125 also has an auxiliary data port for making hard copies of the display with the DECwriter IV Graphics printer. For users who have programs for the older VT105, the VT125 includes a VT105 emulator.

### BOOK INTRODUCTION

This book describes the following products:

VT125-AA and AB Graphics Terminal

VT1XX-CB and -CL Graphics Processors for VT100 and VT105

This user Guide provides general operating information, interface information, control function and ReGIS command descriptions, and specific installation and checkout procedures. The main audiences for this book are the terminal installer, the application programmer and the operator. The operator, however, should use this book only as a reference when operating the terminal. The document which describes the use of the application software is the primary document for the operator.

The information in this user guide is divided by function. This allows you to refer to a specific chapter according to the function to be performed. The chapters are arranged by frequency of use. Since operating information is frequently used by the operator it is at the beginning. Installation is performed only once so it is placed toward the end of the book.

This VT125 User Guide is written for three types of readers:

- the operator needing general operating information, (Chapters 1, 2, 3, 9, and 11)

- the applications programmer needing ReGIS, VT105, control function and communications descriptions, (Chapters 4, 5, 6, 7)
- and the hardware installer needing specific installation and checkout information (Chapters 8, 9, 10 and 11).

Chapter 1 provides a general introduction of how the terminal operates and shows all the controls and indicators of the terminal. This chapter gives the reader a summary of the basic terminal operation. Detailed operating information may depend on the computer software.

Chapter 2 defines SET-UP and describes each SET-UP feature in detail. Many of the SET-UP features of the terminal change the way the terminal communicates with the computer. Detailed information on communication and the related SET-UP features is provided in the Communication chapter.

Chapter 3 describes the characters and codes transmitted by the terminal, and shows the keys required to produce the codes.

Chapter 4 explains to the programmer the use of control functions to control the display, processing, transmission and representation of characters by the terminal. The chapter includes a description of the characters received by the terminal.

Chapter 5 provides the syntax and commands of the ReGIS graphics descriptor.

Chapter 6 provides the syntax and commands of the VT105 emulator.

Chapter 7 describes the types of communication interfaces available on the VT125. This chapter also describes the methods of communicating with the graphics option, the computer and the printer, and describes the SET-UP features used with these devices.

Chapter 8 describes the environmental conditions which should be considered before installing the terminal. A detailed installation procedure is provided. The chapter also has a step-by-step procedure for turning on the terminal and checking that it operates correctly.

Chapter 9 describes all operator maintenance procedures used with the VT125. Also provided is information on self-testing. This information outlines the steps needed to start the built-in tests and understand the results once the tests have run. The chapter also has a general procedure for operator troubleshooting of the terminal.

Chapter 10 describes the VT125 options: the Advanced Video option and the current loop interface adapter, the VT1XX-CB and -CC Graphics Processor upgrades for the VT100 and VT105, and provides installation and checkout instructions.



Chapter 11 describes the accessories and supplies offered for use with the VT125. Included in this chapter is a short description of each accessory and supply, part number and ordering information.

Appendix A lists the specifications of the VT125 terminal.

Appendix B is a summary of the SET-UP feature display.

Appendix C lists the character codes generated by the VT125 terminal.

Appendix D is a summary of the VT125 control functions and ReGIS commands.

Appendix E describes the ANSI code extension techniques used to create escape and control sequences.

Appendix F describes how to write ReGIS commands for both the VT125 and the VK100.

Appendix G explains the HLS color system in the VT125.

Appendix H lists the ReGIS commands used to create art for this book.

Glossary is a list of technical words and their definitions.

Other Terminals is a list and description of terminals offered by DIGITAL.

Warranty Information describes the warranty and services available from DIGITAL.

#### **BOOK METHODS**

This book uses a colored shading to indicate certain features and concepts. This usually indicates a table in the text.

**Notes, Cautions, and Warnings** -- A note contains information that is important enough to set off from the main body of text. A caution contains information essential to the safety of the equipment and software. A warning contains information essential to the safety of personnel.



CHAPTER 1  
OPERATING INFORMATION

**GENERAL**

This chapter has a general overview of how the VT125 operates and a description of the controls and indicators of the terminal. Also provided is a summary of basic operating procedures. Detailed operating information depends on the computer and software that the terminal is connected to.

**TERMINAL OPERATION**

The VT125 Graphic Terminal is a VT100 (Figure 1-1) video text terminal and a Graphics Processor in one package. The Graphics Processor processes graphic commands from a computer to generate an image in its own memory. Then it sends a video representation of that image to the VT100 text terminal's internal monitor screen and to an optional external color monitor. It can also send a bit map representation of the image to a graphic printer. If data coming to the VT125 is not graphic commands or other commands to the Graphics Processor, the Graphics Processor sends the data to the VT100 for processing and display as text or VT100 control functions.

**CONTROLS AND INDICATORS**

The VT125 video terminal has many different controls and indicators. The controls and indicators are explained in four groups:

- Monitor Controls
- Keyboard Controls
- Visual Indicators
- Audible Indicators

**Monitor Controls**

The VT125 terminal has two controls that are located on the rear panel. The controls are the AC Voltage Selection switch and the AC Power ON/OFF switch. Their locations are shown in Figure 1-2.

AC Voltage Selection switch -- The AC Voltage Selection switch lets the VT125 terminal operate with the available AC input voltage. See Installation (Chapter 8) for more information.

CAUTION: Setting the AC Voltage Selection switch to 120 VAC when using 198 to 256 VAC power source will damage the terminal.

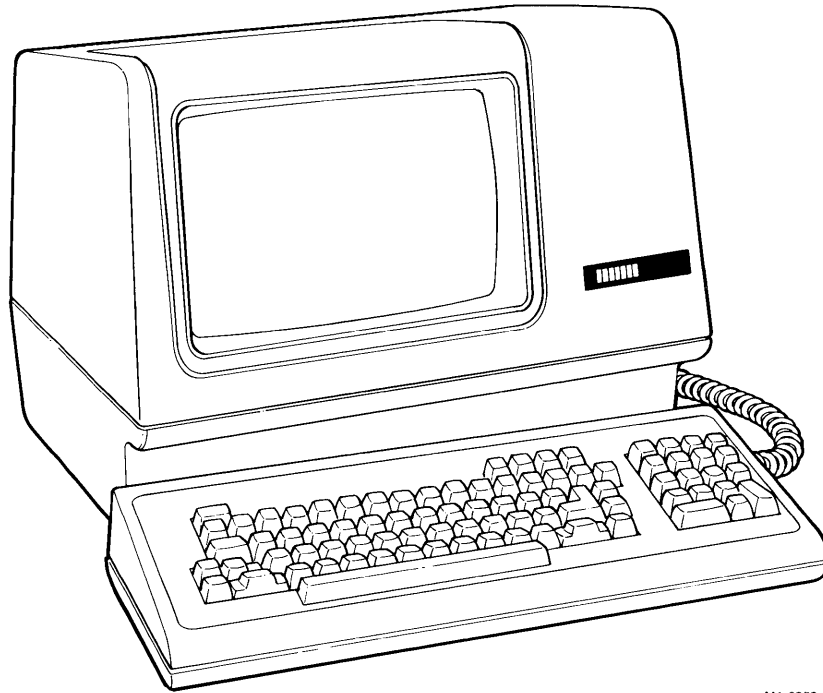

MA-9370-A

Figure 1-1 VT125 Graphics Terminal

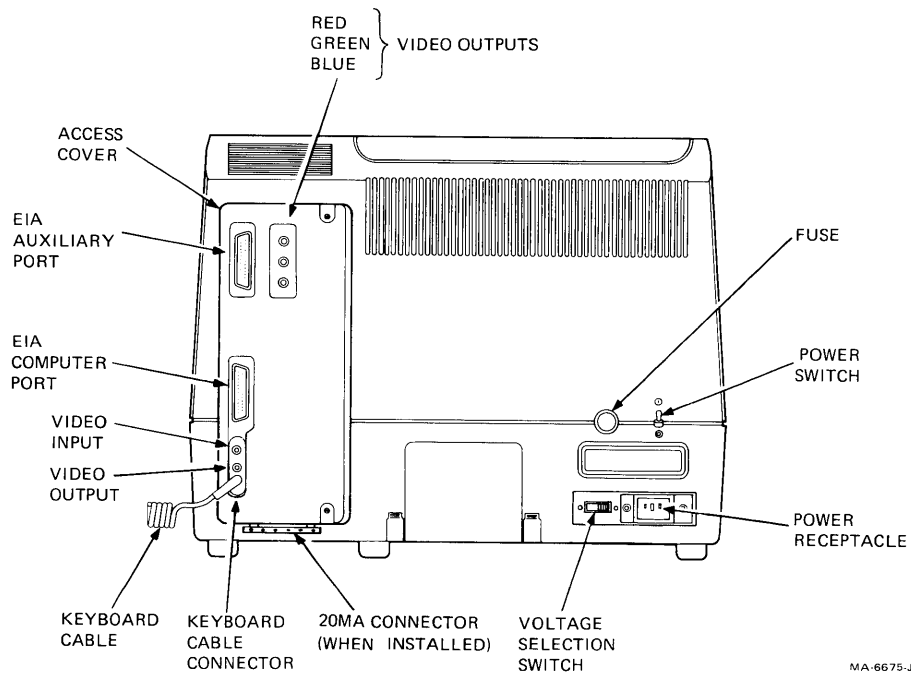

MA-6675-J

Figure 1-2 Monitor Controls and Connector Locations

NOTE: The Voltage Selection switch does not select the AC line frequency Power SET-UP feature. Refer to the SET-UP chapter for more information.

AC Power ON/OFF switch -- The AC Power ON/OFF switch turns ON and OFF the AC power to the terminal. Either the ON LINE or LOCAL keyboard indicators light to show the AC power ON condition. Refer to the indicators section of this chapter for more information on the VT125 indicators.

A Power Up Self Test verifies the proper operation of the VT125 terminal each time the terminal is powered up. Perform the following procedure to power up and checkout the terminal:

1. Turn the Power switch to the on position (refer to Figure 1-2 for the switch location). The terminal automatically runs the Power Up Self Test. The test gives the following indications:
  - Keyboard and screen flash on and off.
  - All keyboard indicators turn on and off, and either the ON LINE or LOCAL indicator is turned on.
  - The Wait message is displayed on the screen and then is erased.
  - A bell tone is generated.
  - A band of light appears at the top of the screen and is erased.
  - Another bell tone is generated.
  - A message appears to announce the result of the VT125 self-test, and a box is drawn\* around the margins of the graphics screen area. (This message stays on the screen until the first character arrives over the communication line.)

NOTE: No message appear on the screen until the terminal warms up.

- The text cursor is displayed in the upper-left corner of the screen.

Any error found by the Power Up Self Test is displayed on the screen as a character, as a message, on keyboard indicators L1-L4, or by several bell tones. Refer to the Self Test Error Codes section of Chapter 9 for more information about the error indications.

|  
\* Not on all units  
|

2. If the terminal powers up correctly, select the SET-UP features you want as described in Chapter 2.

### Keyboard Controls

The VT125 keyboard has a typewriter-styled main keyboard and calculator-like auxiliary keypad. The main keyboard is arranged and operates similar to a standard office typewriter. The auxiliary keypad allows rapid entry of numeric data or function characters.

Some keys of the VT125 keyboard cause the generation of one or more characters immediately when typed. Other keys such as CTRL and SHIFT keys do not cause the generation of characters when typed, but modify the characters generated by other keys. If two character-generating keys are pressed almost at the same time so that they are down at the same time, two characters are generated according to the order in which the keys were typed. The VT125 does not wait for the keys to be lifted, but generates both characters as soon as possible after the keys are typed. If three character-generating keys are pressed at the same time, the characters from the first two keys are generated immediately; the character for the third key is generated when one of the first keys is lifted.

The keyboard keys are divided by function:

- Standard Keys
- Function Keys
- SET-UP Keys

Standard Keys -- Figure 1-3 identifies those keys of the VT125 keyboard that are labeled as standard typewriter and calculator -- like keys. The codes transmitted by each of these keys under various conditions are described in the Terminal Transmissions chapter.

Also, some of the standard typewriter and calculator keys, when used as function keys, may generate control characters. See Chapter 3 for a figure showing the control character generated by each key and see the computer software user guide for the meaning of the keys.

### CAPS LOCK Key

When pressed the CAPS LOCK key causes the generation of uppercase alphabetic characters regardless of the position of the SHIFT key. The CAPS LOCK key locks into position during operation. To release the CAPS LOCK key, press the key again.

The numeric and special symbol keys are not affected by the CAPS LOCK key. The CAPS LOCK key does not affect the auxiliary keypad.

### SHIFT Keys

When pressed the SHIFT keys cause the generation of uppercase characters for the alphabetic, numeric and special symbol keys of the main keyboard. The SHIFT key does not affect the keys of the

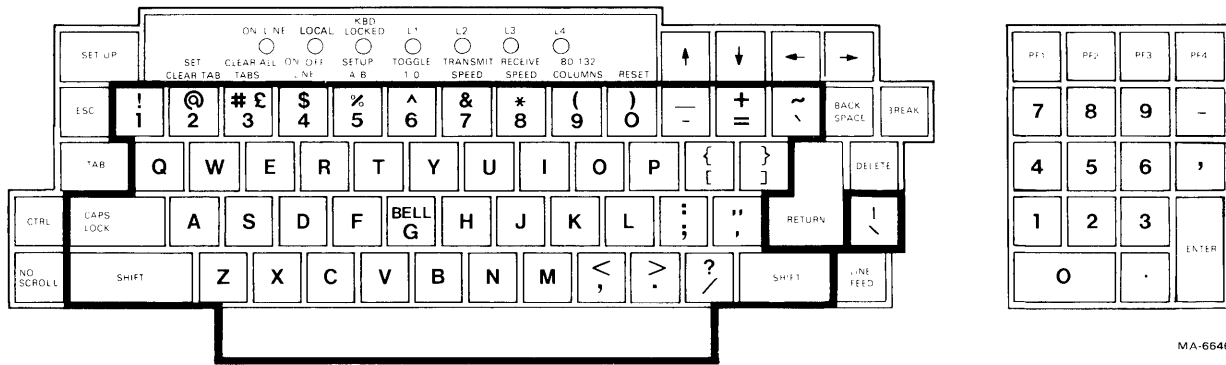

MA-6646-C

Figure 1-3 Standard Keys

auxiliary keypad or Tab, Return, Linefeed, Backspace, Delete, or Space Bar (unlabeled).

#### **Auxiliary Keypad Keys**

The auxiliary keypad lets you enter numbers into the VT125 as if it is a calculator. The minus, comma, period and numeric keys of the auxiliary keypad usually generate the same characters as the corresponding unshifted keys of the main keyboard. The ENTER key corresponds to the RETURN key of the main keyboard.

Function Keys -- Figure 1-4 identifies the function keys of the VT125. The following paragraphs provide general descriptions of these keys.

#### **ESC Key**

When pressed the ESC key causes the generation of the escape character.

#### **TAB key**

When pressed the TAB key causes the generation of the tab character.

#### **CTRL Key**

When pressed in combination with another key, the CTRL key causes the VT125 to generate control characters. Figure 3-3 in Chapter 3 shows which key to press for each control character.

#### **DELETE Key**

When pressed the DELETE key causes the generation of a delete character. The deleted character may or may not be erased from the screen depending on the computer's software.

#### **RETURN Key**

When pressed the RETURN key causes the generation of either a carriage return (CR) or a carriage return and line feed (CRLF). The characters generated are selected using the Line Feed/New Line SET-UP feature. Refer to the SET-UP chapter for more details on this SET-UP feature.

#### **LINE**

##### **FEED Key**

When pressed the LINE FEED key causes the generation of a line feed character.

#### **NO**

##### **SCROLL Key**

When first pressed during the transmission of characters from the computer through the Graphics Processor to the VT125, the NO SCROLL key stops the VT100 from processing characters. The contents of the text display is held in place and scrolling stops. Other activities such as graphics processing or printing may continue. When the NO SCROLL key is pressed a second time, the VT100 continues processing characters, the screen displays the new characters, and scrolling continues.



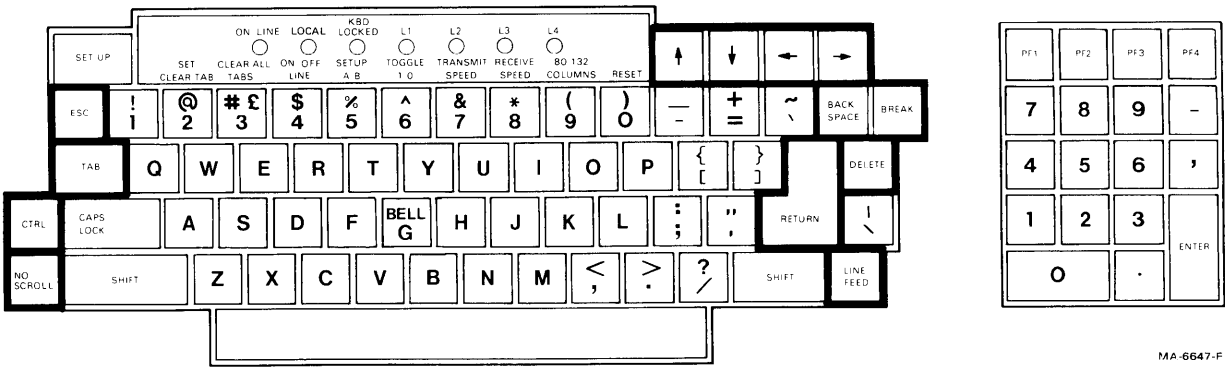

MA-6647-F

Figure 1-4 Function Keys

### **BREAK Key**

The BREAK key causes the generation of a BREAK signal. Refer to the Communication chapter for details on the use of the BREAK signal. The computer response to the BREAK signal depends on the computer and software. See the computer software user guide for details on the use of this key.

When pressed while pressing the SHIFT key, the BREAK key causes a Long Break disconnect. Refer to Communication chapter for details on Long Break disconnects.

When pressed while pressing the CTRL key, the BREAK key causes the VT100 Answerback message to be transmitted. Refer to the SET-UP chapter for more details on the Answerback message.

### **↑ ↓ > < Keys**

These keys usually generate cursor control commands. The cursor is an indicator on the video screen that shows the line and column where the next character is positioned. Each of these keys causes the generation of characters which may have a special meaning to the computer. See the computer software user guide for details on the use of these keys.

### **Auxiliary Keypad**

The auxiliary keypad can be used in two ways depending on your computer software:

- For entering numbers (only PF1, PF2, PF3, PF4 are function keys)
- For special purposes such as video editors (all keys are function keys)

See Chapter 3 for an explanation of the different kinds of keypad function keys. Refer to the computer software user guide for more information on the use of these keys.

SET-UP Keys -- Figure 1-5 identifies the keys which have meaning to the VT125 when operating in SET-UP. There are two SET-UP displays: SET-UP A, and SET-UP B. The SET-UP chapter has a detailed explanation of the use of these keys.

### **SET-UP Key**

When pressed the SET-UP key places the VT125 in SET-UP. While in SET-UP the terminal features can be changed. Entering and exiting SET-UP also cancels any ReGIS Hard Copy command.

@

### **SET/CLEAR TAB 2 Key**

In SET-UP A the SET/CLEAR TAB key sets or clears single horizontal tabs. In SET-UP B this key is inactive.

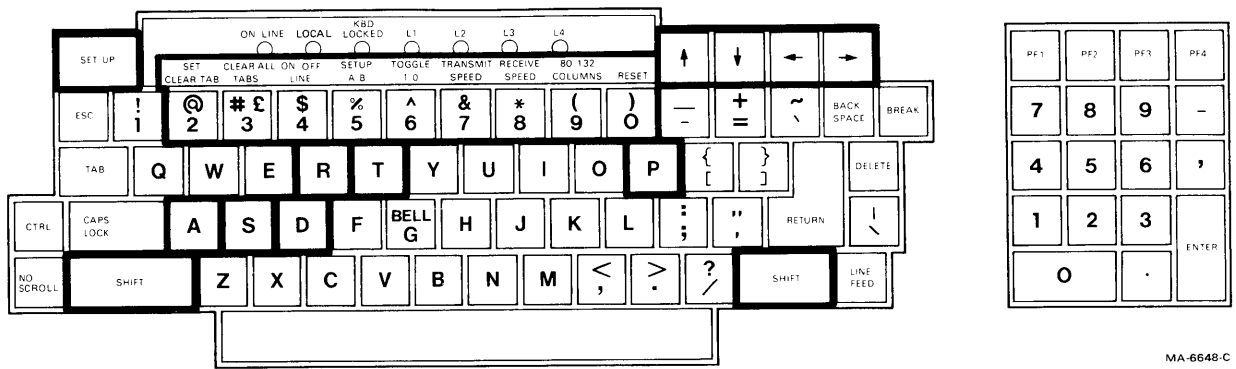

MA-6648-C

Figure 1-5 SET-UP Keys

# E

**CLEAR ALL TABS 3 Key**

In SET-UP A, this key clears all horizontal tabs set. In SET-UP B this key is inactive.

\$

**LINE/LOCAL 4 Key**

In any SET-UP display the LINE/LOCAL key switches the VT125 between ON LINE and LOCAL. While ON LINE the VT125 communicates with the computer through the graphics option. While LOCAL the VT125 cannot communicate with the computer. Instead, the VT100 terminal inside the VT125 communicates only with itself, ignoring the graphics option. However, the graphics option can continue to process data from the computer. Use a data loopback connector with the terminal ON LINE to communicate with the graphic option from the keyboard. See the Maintenance Chapter for instructions.

%

**SET-UP A/B 5 Key**

In SET-UP the SET-UP A/B key switches the VT125 between SET-UP A and SET-UP B.

^

**TOGGLE 1/0 6 Key**

In SET-UP B the TOGGLE 1/0 key turns the selected feature on or off. In SET-UP A this key is inactive.

&

**TRANSMIT SPEED 7 Key**

In SET-UP B the TRANSMIT SPEED key steps the VT125 up through the transmit baud rate settings of the line to the computer. In SET-UP A this key is inactive.

\*

**RECEIVE SPEED 8 Key**

In SET-UP B the RECEIVE SPEED key steps the VT125 through the receive baud rate settings of the line to the computer. In SET-UP A this key is inactive.

(

**80/132 COLUMNS 9 Key**

In SET-UP A the 80/132 COLUMN key switches the display line size between 80 and 132 characters per line. In SET-UP B this key is inactive.

)

**RESET 0 Key**

In any SET-UP display the RESET key starts the reset sequence. This has the same result as turning the VT125 power off and then on.

NOTE: The Reset sequence erases the VT125 memory. This includes the text and graphics display data, any temporarily stored SET-UP feature settings, and any selected graphics protocols.

### **↑ ↓ Keys**

In any SET-UP display the ↑ (up arrow) and ↓ (down arrow) keys raise and lower the brightness of the display.

### **← → Keys**

In any SET-UP display the ← (left arrow) and → (right arrow) keys move the cursor left and right.

### **A Key**

In SET-UP B, while pressing the SHIFT key press the A key to enter the answerback message in the VT125.

### **R Key**

In any of the SET-UP displays, while pressing the SHIFT key, press the R key to recall the previously stored user permanent memory SET-UP feature selections.

### **S Key**

In any of the SET-UP displays, while pressing the SHIFT key, press the S key to store the current SET-UP feature selections in the user permanent memory. See the SET-UP chapter for more details.

### **Keyboard Indicators**

Figure 1-6 shows the location of the keyboard indicators. The following paragraphs describe the function of each indicator.

#### **ON LINE Indicator**

This indicator lights to show that the text terminal is ON LINE and ready to transmit or receive data. When AC power is ON, either the ON LINE or LOCAL indicator is ON.

#### **LOCAL Indicator**

This indicator lights to show that the text terminal is LOCAL and cannot communicate with the computer or the graphics option. When the text terminal is LOCAL, it displays data entered from the keyboard on the screen as if the data came from the computer. When AC power is ON, either the ON LINE or LOCAL indicator is ON. LOCAL should only be used to test the text terminal. Always leave the terminal ON LINE.

#### **KBD LOCKED Indicator**

This indicator lights to show that the keyboard has been turned off (locked) either by the computer or by the terminal itself. Any new characters typed are lost. The terminal can still receive data from the computer.

The computer turns off the keyboard if it cannot process characters as fast as the terminal sends them. The computer turns the keyboard on when it is ready for more characters.

The terminal turns off the keyboard if the transmit baud rate is too slow to send characters as fast as you type them. The terminal turns the keyboard on after it sends the characters you already typed.

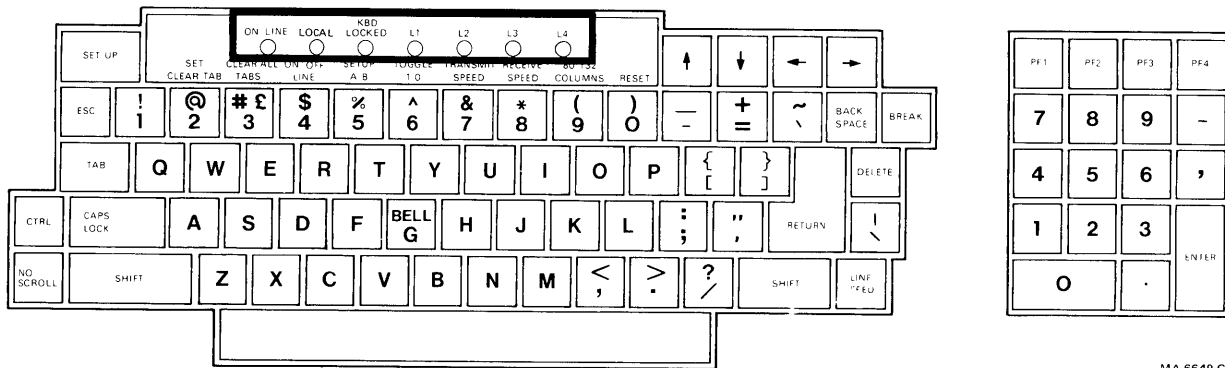

MA-6649-C

Figure 1-6 Keyboard Indicators

NOTE: If you enter and exit SET-UP while the keyboard is locked, characters already typed are lost and the keyboard is unlocked. However, if the computer is not ready to receive characters, characters typed after unlocking may be lost.

#### L1 - L4

These indicators are turned on and off by the computer. See your computer software instructions for the meaning of each indicator. L1 - L4 also show self-test errors.

#### Audible Indicators

There are three audible indicators in the VT125; a keyclick, a long tone (beep), and a series of long tones.

Keyclick -- The terminal generates a keyclick when a key is pressed, with the following exceptions:

- SHIFT or CTRL keys do not generate any keyclick because these keys do not transmit characters but only modify the characters transmitted by other keys.
- KBD LOCKED indicator is on; any keys typed are lost.
- The keyclick feature is off in SET-UP B.

Long Tone (beep) The terminal generates a beep to indicate one of the following conditions:

- A bell character was received from the computer.
- The cursor is eight characters away from the right margin and the margin bell feature is enabled.

#### Series of Long Tones

The terminal generates the long tone many times in a row and the screen displays "2" to indicate that the user permanent memory cannot read or write the SET-UP features. If this happens, check the SET-UP features and then perform the Save or Recall operation again. Service may be needed. See Chapter 9.





CHAPTER 2  
SET-UP FEATURES

**GENERAL**

The VT125 terminal has many features in SET-UP that allow the terminal to be configured for specific applications. This chapter describes SET-UP and each of the SET-UP features.

**SET-UP FEATURES**

SET-UP features change how the VT125 terminal operates. They allow the terminal to be configured to operator preference, and they provide compatibility to the computer and ac power source. Table 2-1 divides the SET-UP features into three general types: operator preference, communication compatibility, and installation.

**Table 2-1 SET-UP Feature Types**

SET-UP Feature	Operator Preference	Communication Compatibility	Installation
ON LINE/LOCAL		X	
Screen brightness	X		
Columns per line		X	
Tab stops		X	
Scroll	X		
Auto repeat	X		
Screen background	X		
Cursor	X		
Margin bell	X		
Keyclick	X		
ANSI/VT52		X	
Auto XON/XOFF		X	
US/UK character set			X
Auto wrap		X	
Line feed/new line		X	
Interface			X
Parity sense		X	
Parity		X	
Bits per character		X	
Power			X

Table 2-1 SET-UP Feature Types

SET-UP Feature	Operator Preference	Communication Compatibility	Installation
AUX port bits per character		X	
AUX port speed		X	
Transmit speed		X	
Receive speed		X	
Answerback		X	

**Operator Preference Features**

These features configure the terminal to operator preference. They do not affect information transferred between the terminal and the computer.

**Communication Compatibility Features**

These features configure the terminal so that it is compatible with a computer. There are many combinations of SET-UP features used when communicating with a computer. The features must be selected correctly for the terminal to communicate with the computer. An error in these selections may stop communication or cause incorrect information to be transferred between the terminal and computer.

NOTE: This chapter describes the SET-UP features used to provide compatibility. More information about using these SET-UP features is provided in Chapter 7.

**Installation Features**

These features configure the terminal for operation in different installations. If the location of the terminal is changed, verify these feature selections.

**FEATURE SELECTION**

SET-UP features can be selected by the computer or from the terminal keyboard. When the computer changes the feature selections, the SET-UP features are not destroyed. However, the current selection is shown by the SET-UP feature display. SET-UP features that can be changed by the computer are listed in Table 2-2. Refer to Chapter 4 for more information about the selection of features by the computer.

To select SET-UP features from the keyboard you must enter SET-UP. SET-UP has two feature displays: SET-UP A and SET-UP B (Figure 2-1. The SET-UP A feature display shows the location of tab stops and a visual ruler numbers each column of the line. The SET-UP B feature display shows the other SET-UP features. Use the following steps to change a SET-UP feature selection.

Table 2-2 SET-UP Features the Computer Can Change

SET-UP Feature	Can be Changed
ON LINE/LOCAL	
Screen brightness	
Columns per line	X
Tab stops	X
Scroll	X
Auto repeat	X
Screen background	X
Cursor	
Margin bell	
Keyclick	
ANSI/VT52	X
Auto XON/XOFF	
US/UK character set	X
Auto wrap	X
Line feed/new line	X
Interface	X
Parity sense	
Parity	
Bits per character	
Power	
AUX port bits per character	
AUX port speed	
Transmit speed	
Receive speed	
Answerback	

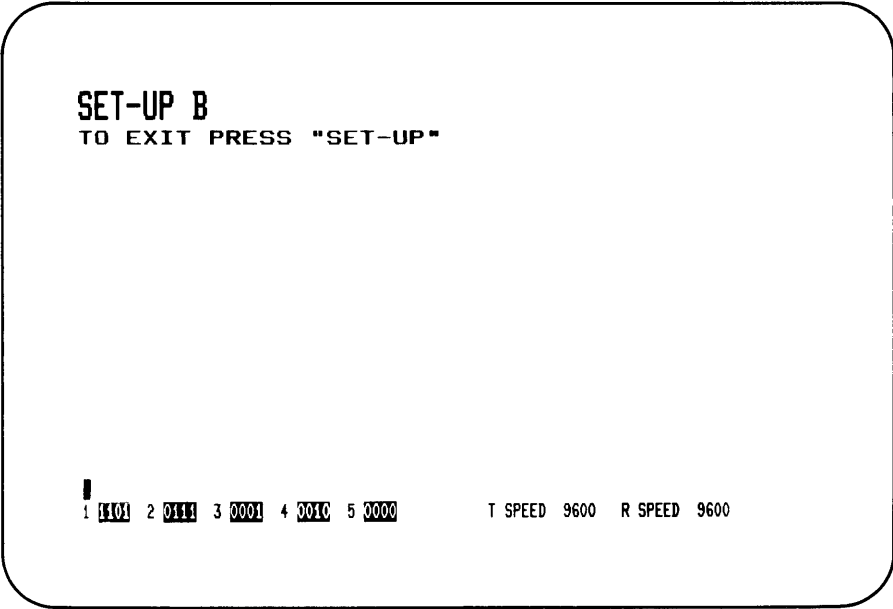
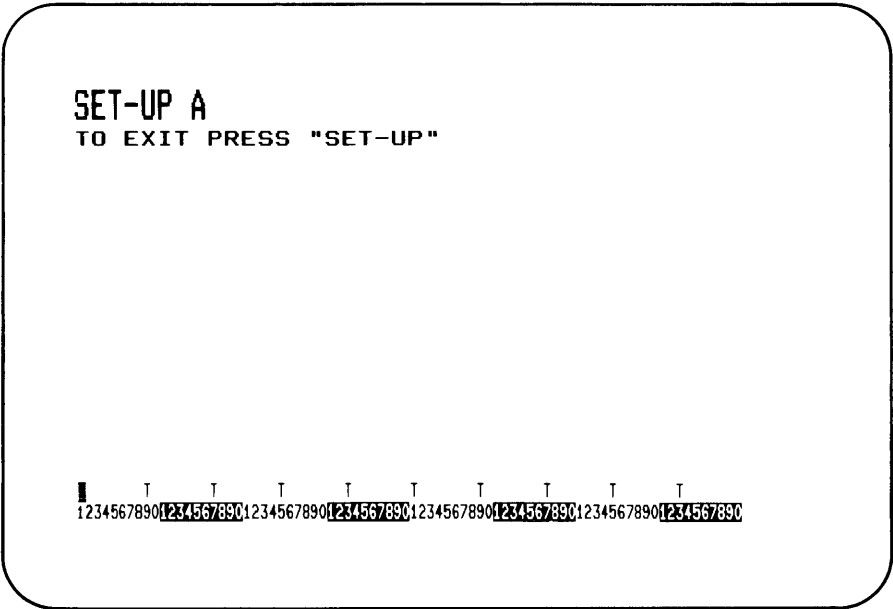

MA-9480

Figure 2-1 SET-UP Displays

Procedure	Indication/Comments
Press the SET-UP key to enter SET-UP.	SET-UP A is displayed on the screen.
Press SETUP A/B to select the correct SET-UP display.	The selected SET-UP display shows on the screen.
Change the SET-UP feature selection.	The SET-UP display shows the feature selection.
Store the SET-UP features if desired.	The terminal displays wait and then SET-UP A.
Press SET-UP to exit SET-UP.	

NOTE: Entering and exiting SET-UP with KBD LOCKED on clears the keyboard locked condition and erases any characters that were typed after the keyboard was locked. Entering and exiting SET-UP also cancels any ReGIS Hard Copy command.

#### ENTERING AND EXITING SET-UP

You can enter SET-UP while either ON LINE or LOCAL.

#### FEATURE MEMORIES

The SET-UP feature selections are stored in three memories: operating (temporary), user permanent, and default (Figure 2-2).

#### Operating Memory

This memory stores the SET-UP feature selections used to operate the terminal. The terminal always operates according to these features. The features can be selected at the terminal keyboard or by the computer. In SET-UP, the feature selections in the operating memory are shown on the screen. To change the SET-UP feature selections stored in memory perform the following procedure at the terminal keyboard.

Procedure	Indication/Comments
Press the SET-UP key to enter SET-UP.	SET-UP A is displayed on the screen.
Press SETUP A/B to select the correct SET-UP display.	The selected SET-UP display shows on the screen.
Change the SET-UP feature selection.	The SET-UP display shows the feature selection.
Press the SET-UP key exit SET-UP.	The terminal operates according to the new SET-UP feature selections in operating memory.

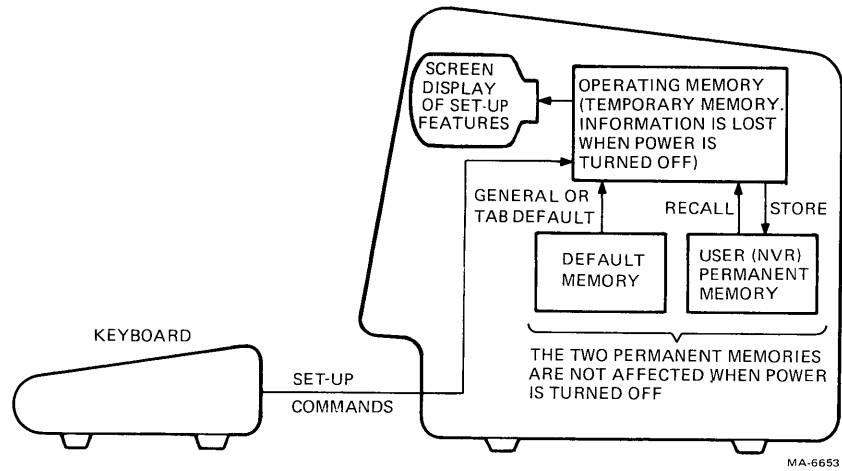

Figure 2-2 SET-UP Feature Memories

If a recall or reset procedure is performed, or power to the terminal is turned off and on, all operating memory SET-UP feature selections are replaced by the SET-UP feature selections in user permanent memory.

#### User Permanent Memory

This memory stores selected SET-UP features permanently. The computer cannot change SET-UP feature selections in user permanent memory. User permanent memory can only be changed by performing a store from the terminal keyboard while in SET-UP. Turning power off does not affect SET-UP feature selections in this memory. SET-UP features are moved between operating memory and user permanent memory by performing store, recall, or reset procedures.

Store -- This procedure stores the operating memory SET-UP feature selections in user permanent memory. Storing is performed from the terminal keyboard. The computer cannot store SET-UP feature selections in user permanent memory. To store SET-UP feature selections in user permanent memory, perform the following procedure.

Procedure	Indication/Comments
Press the SET-UP key to enter SET-UP.	SET-UP A is displayed on the screen.
Hold down the SHIFT key, press the S key; then release both keys.	The terminal displays wait and then SET-UP A.
Press the SET-UP key to exit SET-UP.	

Recall -- This procedure recalls the user permanent memory SET-UP feature selections into operating memory. All feature selections previously in operating memory are erased. Also, the text screen memory is erased. To recall the SET-UP feature selections from user permanent memory into operating memory, perform the following procedure.

Procedure	Indication/Comments
Press the SET-UP key to enter SET-UP.	SET-UP A is displayed on the screen.
Hold down the SHIFT key, press the R key; then release both keys.	The terminal displays wait and then SET-UP A.
Press the SET-UP key to exit SET-UP.	

NOTE: Some features selected by the computer may be affected.

Reset -- This procedure resets the terminal, erases all memories and performs a self-test. Also, reset recalls the user permanent memory SET-UP feature selections into operating memory. All feature selections previously in operating memory are erased. To reset the terminal, perform the following procedure.

Procedure	Indication/Comments
Press the SET-UP key to enter SET-UP.	SET-UP A is displayed on the screen.
Press RESET.	The power-on self-test runs. The terminal operates according to the SET-UP feature selections in user permanent memory. The terminal automatically exits SET-UP.

### SET-UP DEFAULT MEMORY

The VT125 has default SET-UP feature selections for all the VT125 SET-UP features. These default selections cannot be changed by the user. When a default occurs (usually because of a problem in the user permanent memory), all operating memory SET-UP feature selections change to the default selections. The SET-UP features in user permanent memory are not changed by a default. Figure 2-3 shows the default SET-UP feature selections.

### SET-UP FEATURE DEFINITIONS

The SET-UP feature definitions in this section are arranged by the SET-UP display in which they are changed. A general procedure for changing each SET-UP feature in the SET-UP display is provided at the beginning of each SET-UP display section. For features needing a more detailed procedure, the procedure is given with the SET-UP feature description. The first section includes the general features changed in either SET-UP A or SET-UP B.

NOTE: Entering set-up and changing features usually does not cause the loss of characters in the VT125 text memory. Any action that does cause loss is explained.

### General SET-UP Features

The ON LINE/LOCAL and Screen Brightness SET-UP features may be changed in any SET-UP display. Dedicated keys on the main keyboard select these features. Each feature description includes the specific change procedure.

### ON LINE/LOCAL

The ON LINE/LOCAL feature places the terminal either ON LINE or LOCAL. While ON LINE (the keyboard ON LINE indicator is on) the text terminal transfers data to and from the computer through the Graphics Processor.

While LOCAL (the keyboard LOCAL indicator is on) the text terminal does not transfer data to or from the Graphics Processor. Characters typed on the keyboard are echoed to the screen



TABS  
 COLUMNS PER LINE  
 ON/OFF LINE  
 ANSWERBACK

EVERY 8 COLUMNS STARTING AT 9  
 80  
 LOCAL  
 NONE

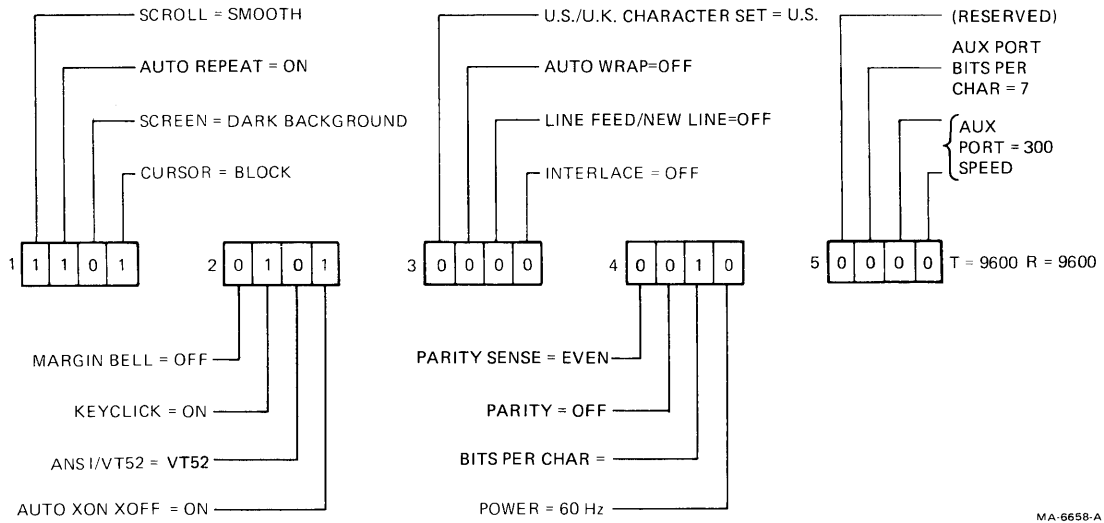

MA-6658-A

Figure 2-3 SET-UP Default Feature Selections

directly. LOCAL should only be used to test the text terminal. Always leave the terminal ON LINE.

Perform the following procedure to select the ON LINE or LOCAL condition:

Procedure	Indication/Comments
1. Press the SET-UP key to enter SET-UP.	SET-UP A is displayed on the screen.
2. Press the OFF/ON LINE key to select on-line or off-line.	The ON LINE and OFF LINE keyboard indicators show the feature selection.
3. Press the SET-UP key to exit SET-UP.	The characters displayed on the screen when entering SET-UP are again displayed on the screen.

### SCREEN BRIGHTNESS

The VT125 electronically controls screen brightness. The ↑ (up arrow) key increases the screen brightness; the ↓ (down arrow) key decreases the screen brightness.

Perform the following procedure to select the wanted screen brightness:

Procedure	Indication/Comments
1. Press the SET-UP key to enter SET-UP.	SET-UP A is displayed on the screen.
2. Press the ↑ (up arrow) or ↓ (down arrow) key to select brightness.	SET-UP display is the brightness selected.
3. Press the SET-UP key to exit SET-UP.	The characters displayed on the screen when entering SET-UP are again displayed on the screen.

### SET-UP A Features

The following paragraphs describe the SET-UP A features in detail:

#### CHARACTERS PER LINE

The characters per line feature selects a display of either 80 or 132 characters per line. With 80 characters per line selected, the screen is 80 characters wide and 24 lines long. With 132 characters per line selected, the screen is 132 characters wide and 14 lines long (132 characters by 24 lines long if the advanced video option is installed). The displayed lines with 132 characters per line selected are the same width on the video screen as the 80 character per line selection but the characters are narrow and closer together. Figure 2-4.

These are characters displayed using 80 columns.

These are characters displayed using 132 columns.

MA-7775

Figure 2-4 80- and 132-Column Displays

NOTE: Changing the characters per line erases the current contents of the screen.

Perform the following procedure to select the number of characters per line:

Procedure	Indication/Comments
1. Press the SET-UP key to enter SET-UP.	SET-UP A is displayed on the screen.
2. Press the 80/132 COLUMNS key to select the number of columns per line.	The bottom line of the display is a "ruler" which numbers each column position on a line. This ruler indicates the feature selection.
3. Press the SET-UP key to exit SET-UP, or press the SET-UP A/B key to enter SET-UP B.	The characters displayed on the screen before entering SET-UP are lost. When exiting SET-UP the screen is blank.

#### TABS

Tab stops are preselected points on a line of the VT125 display. The VT125 cursor can tab (advance) to the tab stops on the display line. The tab stops may be changed one at a time, or all cleared and then set.

The 2 (SET/CLEAR TAB) key of the main keyboard sets and clears single tab stops. The 3 (CLEAR ALL TABS) key of the main keyboard clears all tab stop settings.

Do the following procedure to set and clear tab stops.

Procedure	Indication/Comments
1. Press the SET-UP key to enter SET-UP.	SET-UP A is displayed on the screen.
2. Press the CLEAR ALL TABS key or the SET/CLEAR TABS key	All tabs are cleared. The tab is set or cleared at the cursor position.  The cursor is moved using the < (left arrow), > (right arrow), RETURN, TAB and SPACE BAR keys.
3. Press the SET-UP key to exit SET-UP, or press the SET-UP A/B key to enter SET-UP B.	The characters displayed on the screen when entering SET-UP are again displayed on the screen.

## SET-UP B Features

Figure 2-5 is the SET-UP B summary. The bottom line of the display is a row of switches indicating the features selected. Change SET-UP feature switch selections using the following procedure.

Procedure	Indication/Comments
1. Press the SET-UP key to enter SET-UP.	SET-UP A is displayed on the screen.
2. Press the SET-UP A/B key to enter SET-UP B.	SET-UP B is displayed on the screen.
3. Position the cursor over the SET-UP feature switch to be changed.	The cursor is positioned using the < (left arrow), > (right arrow), RETURN, TAB and SPACE BAR keys.
4. Use the TOGGLE 1/Ø key to select the feature.	The screen displays the feature selection.
5. Press the SET-UP key to exit SET-UP, or press the SETUP A/B key to enter SET-UP A.	The characters displayed on the screen when entering SET-UP are again displayed on the screen.

The following paragraphs describe the features in the order of the switches on the screen. The switches are referred to within this chapter by the group and the number of the switch within the group. (Example: switch 3-2 is the third group of switches -- second switch counting from left to right.) The answerback feature is listed at the end of the feature descriptions.

### SCROLL

Switch 1-1: Ø = Jump, 1 = Smooth

Scrolling is the up or down movement of lines of text on the screen. Scrolling is performed to make room for new lines at the bottom or top of the screen. It can be performed in two ways: jump scroll or smooth scroll.

With jump scroll selected, new lines are displayed on the screen as fast as the terminal receives them. At the higher baud rates, the lines displayed are difficult to read because of their rapid movement.

With smooth scroll selected, there is a limit to the speed at which new lines are displayed by the terminal. The movement of lines occurs at a smooth steady rate allowing the lines to be read as they are displayed on the screen.

NOTE: Smooth scroll allows a maximum of six lines per second to be added at the top or bottom of the screen. The Auto XON/XOFF

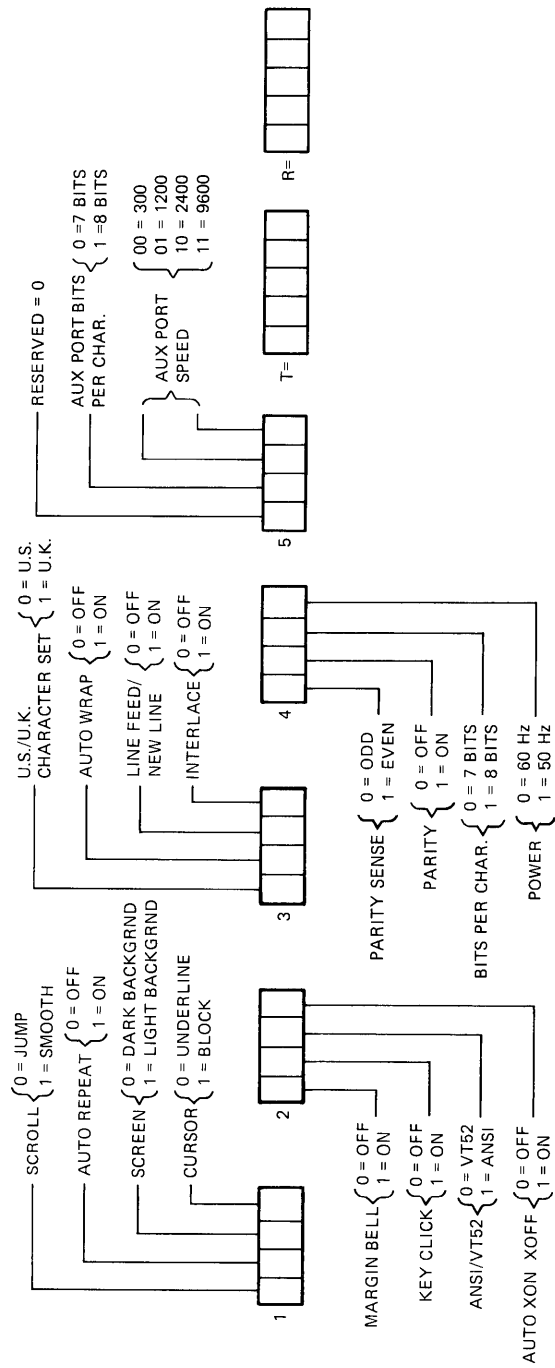

MA-6652A

Figure 2-5 SET-UP B Summary

feature must be supported by the computer to make sure that characters are not lost when smooth scroll is selected.

**AUTO REPEAT**

Switch 1-2: 0 = off, 1 = on

The auto repeat feature causes a key to be automatically repeated at the rate of about 30 characters per second when the key is held down for more than one half second. The auto repeat feature affects all keyboard keys except the following:

SET-UP  
ESC  
RETURN  
ENTER  
NO SCROLL  
CTRL and any key

When the feature is turned off, only one character is transmitted each time the key is pressed.

**SCREEN BACKGROUND**

Switch 1-3: 0 = Dark, 1 = Light

The screen background feature of the VT125 determines the background of the screen. With dark background selected, the display has light characters on a dark background. With light background (reverse screen) selected, the display has dark characters on a light background. Figure 2-6.

**CURSOR**

Switch 1-4: 0 = Underline, 1 = Block

The cursor feature offers a choice of two cursor displays to indicate the "active position" or where the next character will be put on the screen. The cursor is displayed as either a blinking underline ( ) or a blinking block (■). If the advanced video option is not installed, this feature, also affects the character attribute. See Select Graphic Rendition in Section 2 Chapter 4.

**MARGIN BELL**

Switch 2-1: 0 = OFF, 1 = ON

The margin bell feature causes a tone if the cursor is eight characters from the end of the current line while typing. The margin bell can be turned on or off.

The margin bell volume is not adjustable.

**KEYCLICK**

Switch 2-2: 0 = OFF, 1 = ON

Keyclick is a sound which is generated every time a key is pressed. The keyclick of the VT125 can be turned on or off. However, research and experience has shown that an operator types fewer errors when there is an audible feedback from the keyboard.

The keyclick volume is not adjustable.

**ANSI/VT52**

Switch 2-3: 0 = VT52, 1 = ANSI

The VT125 terminal follows two different programming standards -- American National Standards Institute (ANSI) and VT52 compatible. With ANSI selected, the VT125 generates and responds to control sequences according to ANSI standards X3.41-1974 and X3.64-1979.

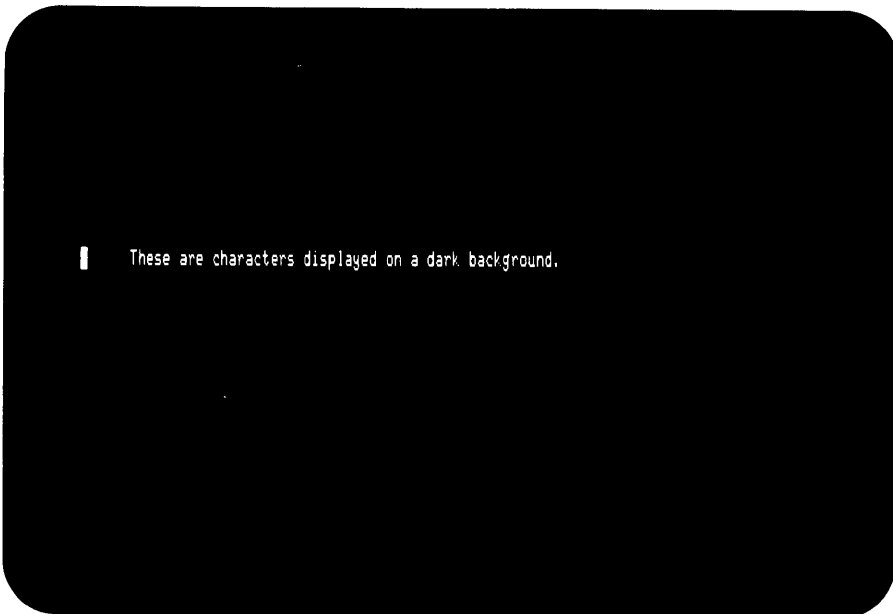
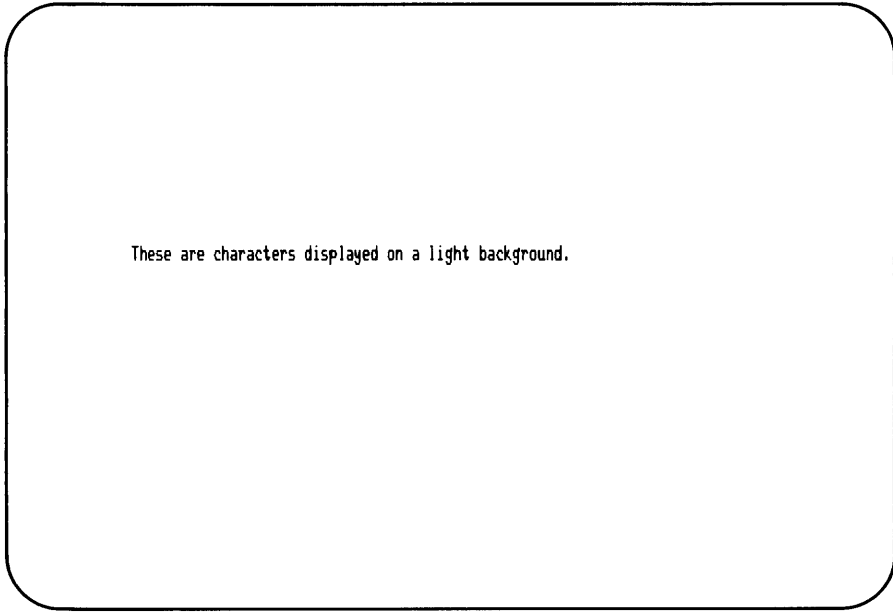

MA-7812

Figure 2-6 Screen Background



With VT52 compatible selected, the VT125 terminal is compatible with previous DIGITAL software using the VT52 video terminal. But because the Graphics Processor only uses ANSI, at power-up it sends the VT52 mode control function to the text terminal to force this SET-UP feature to ANSI regardless of the user permanent memory setting. After power-up, you must manually set this switch to use VT52 modes.

**AUTO XON/XOFF**                      Switch 2-4: 0 = OFF, 1 = ON  
The VT125 Graphics Processor requires the XON (DC1) and XOFF (DC2) control characters. Therefore, this feature cannot be turned off. See the Communications chapter for more information about XON and XOFF.

**U.S./U.K. CHARACTER SET**      Switch 3-1: 0 = #, 1 = £  
The VT125 includes character sets for the United States and the United Kingdom. The difference between the two character sets is one character, the # (number) or £ (pound) symbol.

**AUTO WRAP**                              Switch 3-2: 0 = OFF, 1 = ON  
The auto wrap feature selects where a received character is displayed when the cursor is at the right margin. When the auto wrap feature is off, the character and all following characters are written into the last column of the current line. When this feature is on, the character is automatically displayed on the next line.

**LINE FEED/NEW LINE**              Switch 3-3: 0 = OFF, 1 = ON  
The Line Feed/New Line feature determines the control character(s) transmitted when the RETURN key is pressed and what action is taken by the VT125 when it receives a line feed control character. See Table 2-3.

When the Line Feed/New Line feature is off (line feed mode) pressing the RETURN key generates only the carriage return (CR) control character; when a line feed (LF) control character is received, the cursor moves down to the next line and maintains the current column position.

When the Line Feed/New Line feature is on (new line mode), pressing the RETURN key generates the carriage return (CR) and line feed (LF) control characters. When a line feed control character is received, the character is responded to as both a carriage return and line feed. Therefore, a received line feed causes the cursor to move to the left margin of the next line.

NOTE: The meaning of line feed varies according to your computer system's software. Be sure you need this feature before you turn it on.

**INTERLACE**                              Switch 3-4: 0=OFF; 1=ON  
The Interlace feature selects the number of scan lines used to create characters on the screen. With Interlace on, the terminal uses 480 scan lines per screen. With Interlace off, the terminal

**Table 2-3 Line Feed/New Line Feature Summary**

Selection	Key	Character Sent
Off	RETURN	Carriage return (CR)
Off	LINE FEED	Line feed (LF)
On	RETURN	Carriage return -- line feed (CR LF)
On	LINE FEED	Line feed (LF)
Selection	Character Received	Function
Off	CR	Carriage return (cursor moves to left margin)
Off	LF	Line feed (cursor moves to next line but stays in same column)
On	CR	Carriage return (cursor moves to left margin)
On	LF	Carriage return -- line feed (cursor moves to left margin on next line)

uses 240 scan lines per screen. This feature does not add any new information to the screen. However, when on, the Interlace feature may improve the output of hard copy or video devices connected to the video output connector. Usually operators prefer to have this feature off.

**PARITY SENSE**

Switch 4-1: 0 = ODD, 1 = EVEN

The parity sense feature defines which of the two methods of parity checking, odd or even, is being used by the VT125. If the parity feature is on, the terminal's parity sense must be the same value as the parity the computer is sending. If the parity sense features do not match, most characters sent by the computer are rejected even though the character was received correctly by the VT125. If a parity error occurs, the checkerboard character (⌘) appears on the screen instead of the received character.

**PARITY**

Switch 4-2: 0 = OFF, 1 = ON

Parity, when on, checks received data for correctness and adds a parity bit to transmitted data. If a received data error occurs, the VT125 can detect it and show its presence by placing a checkerboard character ⌘ on the screen instead of the character

with the error. The parity sense feature determines if the parity is even or odd. When parity is off, no parity bit is received or transmitted.

**BITS PER CHARACTER**                      Switch 4-3: 0 = 7 BITS, 1 = 8 BITS  
This feature allows the terminal to transmit and receive either 7- or 8-bit characters. When set for 8-bit operation, bit 8 is set to a space (or 0) for characters transmitted and is ignored for all characters received.

**POWER**                                      Switch 4-4: 0 = 60 Hz, 1 = 50 Hz  
During the initial installation of the VT125, the power feature must be set to the power line frequency. In the United States this setting is 60 Hz. When using 50 Hz line frequency set this feature to 50 hz.

**AUX PORT BITS PER CHARACTER**      Switch 5-2: 0 = 7 BITS, 1 = 8 BITS  
This switch sets the auxiliary port to match the character length of your printer or other serial device. When set to 8 bits, the eighth bit is a space. This is the same as 7S or 8N on other terminals.

**AUX PORT SPEED**                              Switches 5-3 and 5-4  
These switches set the auxiliary port to one of four baud rates:

XX00	300 baud
XX01	1200 baud
XX10	2400 baud
XX11	9600 baud

Set the switches to match the speed of your auxiliary device.

**TRANSMIT SPEED**  
Transmit speed must be set to match the computer receive speed. The VT125 can transmit at any one of the following speeds: 50, 75, 110, 134.5, 150, 200, 300, 600, 1200, 1800, 2000, 2400, 3600, 4800, 9600, 19200 baud.

Transmit speed is independent of receive speed; the terminal may transmit data at one speed and receive data at a different speed.

To change the transmit speed, perform the following steps:

Procedure	Indication/Comments
1. Press the SET-UP key to enter SET-UP.	SET-UP A is displayed on the screen.
2. Press the SETUP A/B key to enter SET-UP B.	SET-UP B is displayed on the screen.
3. Press the TRANSMIT SPEED key to select the transmit speed.	The terminal displays the current feature selection.
4. Press the SET-UP key to exit SET-UP, or press the SETUP A/B key to enter SET-UP A.	The characters displayed on the screen when entering SET-UP are again displayed on the screen.

#### RECEIVE SPEED

Receive speed must be set to match the computer transmit speed. The VT125 can receive at any one of the following speeds: 50, 75, 110, 134.5, 150, 200, 300, 600, 1200, 1800, 2000, 2400, 3600, 4800, 9600, 19200 baud.

Receive speed is independent of transmit speed; the terminal may receive data at one speed and transmit data at a different speed.

To change the receive speed, perform the following steps:

Procedure	Indication/Comments
1. Press the SET-UP key to enter SET-UP.	SET-UP A is displayed on the screen.
2. Press the SETUP A/B key to enter SET-UP B.	SET-UP B is displayed on the screen.
3. Press the RECEIVE SPEED key to select the receive speed.	The terminal displays the current feature selection.
4. Press the SET-UP key to exit SET-UP, or press the SETUP A/B key to enter SET-UP A.	The characters displayed on the screen when entering SET-UP are again displayed on the screen.

#### ANSWERBACK Message

The answerback feature provides the VT125 with the capability of transmitting an identifying message to the computer. The

answerback message is transmitted to the computer under the following conditions:

- The answerback message is transmitted under a direct request for identification by the computer. The complete answerback sequence happens automatically without affecting the screen or requiring operator action.
- The operator manually transmits the answerback message. While pressing the CTRL key, press the BREAK key and release both keys to manually transmit the answerback message.

Enter an answerback message using the following steps (see Figure 2-7):

Procedure	Indication/Comments
1. Press the SET-UP key to enter SET-UP.	SET-UP A is displayed on the screen.
2. Press the SETUP A/B key to enter SET-UP B.	SET-UP B is displayed on the screen.
3. Hold down the SHIFT key, press the A key and release both keys.	The terminal displays A = (refer to Figure 3-11).
4. Type the message delimiter character.	This is any character not used in the answerback message. The message delimiter character is not transmitted as part of the answerback message.
5. Type the answerback message.	The answerback message may be up to 20 characters. If control characters are used they are displayed as the (<>) character.  If a mistake is made while typing the message, type the delimiter character (used in step 4) and go back to step 3. This is the only way to correct errors in the answerback message.
6. If less than 20 characters are in the message, type the delimiter character.	If 20 characters are typed, the message is automatically entered into operating memory. If less than 20 characters are typed the delimiter character is used to enter the message into operating memory.
7. Press the SET-UP key to exit SET-UP, or press the SETUP A/B key to enter SET-UP A.	The characters displayed on the screen when entering SET-UP are again displayed on the screen.

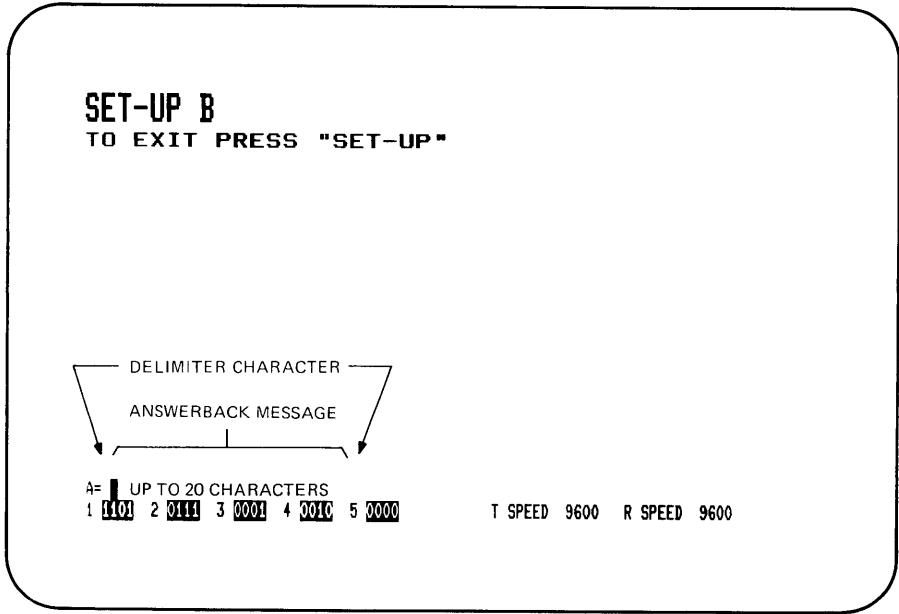

MA-9479

Figure 2-7 Answerback Message

#### GENERAL

This chapter describes the character codes generated by the VT125 terminal. The keys are divided into three groups: standard keys, function keys, and auxiliary keypad keys.

#### STANDARD KEYS

The standard keys are shown in Figure 3-1. The terminal generates American Standard Code for Information Interchange (ASCII) character codes. Lowercase ASCII character codes are generated when SHIFT or CAPS LOCK are not pressed. Uppercase ASCII character codes are generated when either SHIFT or CAPS LOCK are pressed. CAPS LOCK does not affect the nonalphabetic keys.

#### FUNCTION KEYS

The function keys are shown in Figure 3-2. These keys generate character codes whose function is defined by the computer software or communication system. The following paragraphs describe the function keys.

#### BREAK Key

The BREAK key generates a BREAK signal. The Break signal function is defined by the computer system. Refer to Chapter 5 for more information about the Break signal.

Hold down the SHIFT key, and press the BREAK key to generate a Long Break Disconnect. A Long Break Disconnect usually disconnects the terminal from the communication line. Refer to Chapter 5 for more information about Long Break Disconnect.

Hold down the CTRL key, and press the BREAK key to generate the answerback message. Refer to Chapter 2 for more information about the Answerback SET-UP B feature.

#### ↑ ↓ ← → Cursor Control Keys

The cursor key character codes generated by the terminal depend on the ANSI/VT125 feature selection. When the ANSI/VT125 feature is set for ANSI compatibility, the cursor keys generate sequences that depend on the cursor key mode selection. Cursor key mode is only selected by the computer. Refer to Chapter 4 for more information about cursor key character selection. Table 3-1 lists the ANSI and VT52 compatible cursor key character codes.

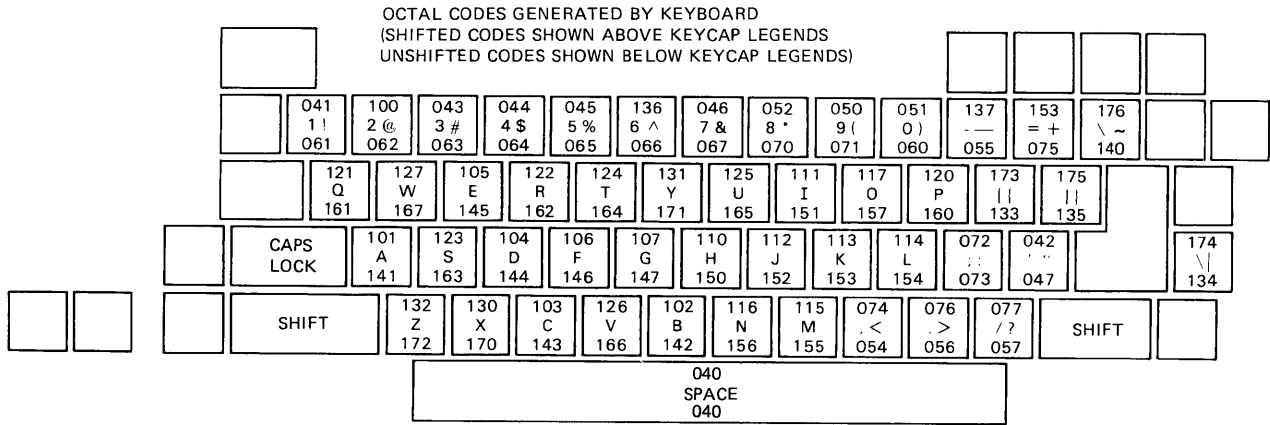

MA-741B

Figure 3-1 Standard Key Codes

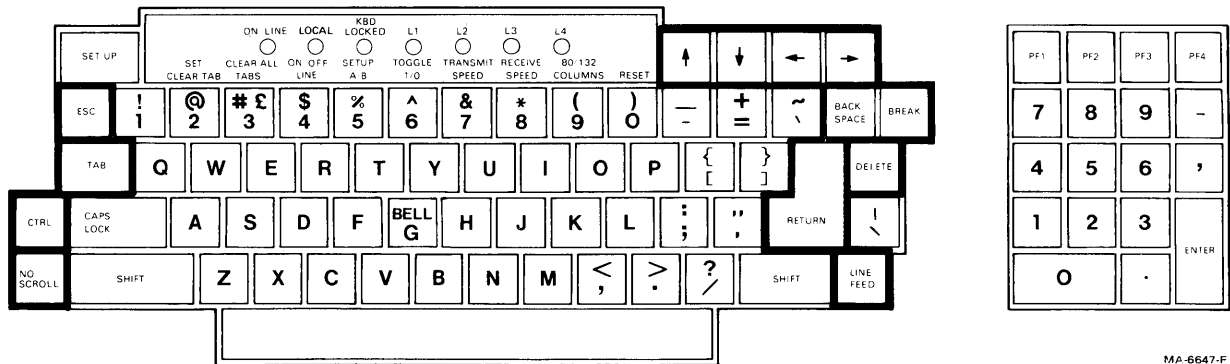

MA-6647-F

Figure 3-2 Function Keys



Table 3-1 Cursor Control Key Codes

Cursor Key	ANSI Mode		VT52 Mode
	Cursor Key Mode Reset	Cursor Key Mode Set	
↑	ESC [ A Ø33 133 1Ø1	ESC O A Ø33 117 1Ø1	ESC A Ø33 1Ø1
↓	ESC [ B Ø33 133 1Ø2	ESC O B Ø33 117 1Ø2	ESC B Ø33 1Ø2
→	ESC [ C Ø33 133 1Ø3	ESC O C Ø33 117 1Ø3	ESC C Ø33 1Ø3
←	ESC [ D Ø33 133 1Ø4	ESC O D Ø33 117 1Ø4	ESC D Ø33 1Ø4

Table 3-2 Comparison of Control Character Generation

Code	VT125 Keys	Previous Terminal Keys
NUL	CTRL -- Space bar	CTRL -- @
RS	CTRL -- ~	CTRL -- ^
US	CTRL -- ?	CTRL -- _

### Control Character Keys

Figure 3-3 shows the keys that generate control characters. Control characters can be generated in two ways:

1. Hold down the CTRL key, and press any of the unshaded keys in Figure 3-3.
2. Press any of the shaded keys in Figure 3-3 without using the CTRL key. the shaded keys are dedicated keys that generate control characters without using CTRL.

NOTE: The RETURN key character code can be changed by the line feed/new line feature. When off, this feature causes RETURN to generate a single control character (CR). When on, this feature causes RETURN to generate two characters (CR, LF). Also, depending on the auxiliary keypad mode selected, RETURN and ENTER may generate the same control codes.

Table 3-2 lists the control characters that are generated differently from previous DIGITAL terminals. No details are provided about the function of the control character codes because different computer systems may use each control character differently.

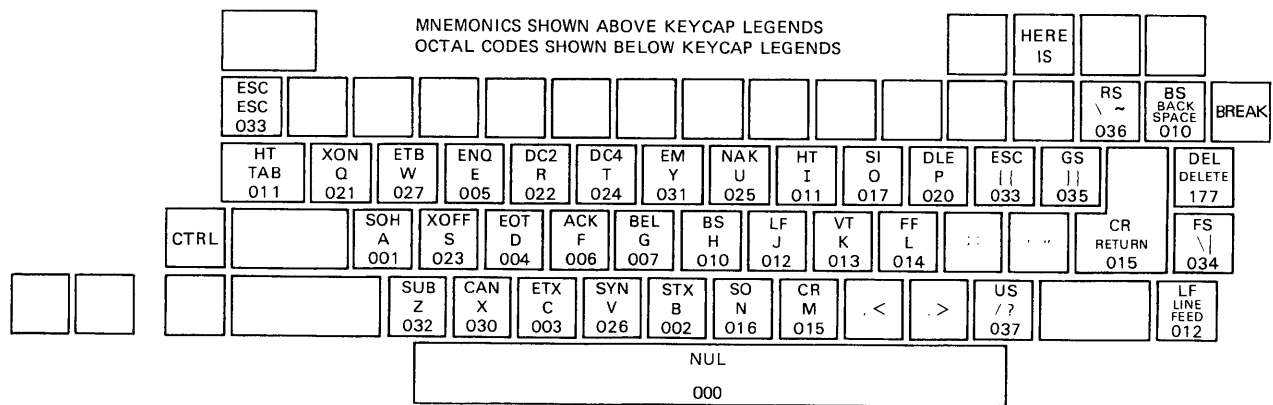

MA 7419

Figure 3-3 Function Key Control Codes

## AUXILIARY KEYPAD KEYS

The characters generated by the auxiliary keypad keys change depending on the selection of two features: ANSI/VT52 and Alternate Keypad features. The Alternate Keypad feature is usually selected only by the computer. Refer to Chapter 4 for more information about keypad character selection.

When alternate keypad mode is not selected (numeric keypad mode is selected), the auxiliary keypad generates the numeric, comma, period, and minus sign character codes used by the main keyboard.

NOTE: SHIFT and CAPS LOCK do not affect the codes generated by the auxiliary keypad.

When alternate keypad mode is selected, the auxiliary keypad generates control functions. Table 3-3 lists the character codes generated by the auxiliary keypad.

**Table 3-3 Auxiliary Keypad Codes**

Key	ANSI Mode			VT52 Mode			
	Numeric Keypad Mode	Alternate Keypad Mode		Numeric Keypad Mode	Alternate Keypad Mode		
0	0 060	ESC 033	0 117	p 160	0 060	ESC ? 033 077	P 160
1	1 061	ESC 033	0 117	q 161	1 060	ESC ? 033 077	q 161
2	2 062	ESC 033	0 117	r 162	2 062	ESC ? 033 077	r 162
3	3 063	ESC 033	0 117	s 163	3 063	ESC ? 033 077	s 163
4	4 064	ESC 033	0 117	t 164	4 064	ESC ? 033 077	t 164
5	5 065	ESC 033	0 117	u 165	5 065	ESC ? 033 077	u 165
6	6 066	ESC 033	0 117	v 166	6 066	ESC ? 033 077	v 166
7	7 067	ESC 033	0 117	w 167	7 067	ESC ? 033 077	w 167
8	8 070	ESC 033	0 117	x 170	8 070	ESC ? 033 077	x 170

**Table 3-3 Auxiliary Keypad Codes (Cont)**

Key	ANSI Mode						VT52 Mode			
	Numeric Keypad Mode		Alternate Keypad Mode				Numeric Keypad Mode		Alternate Keypad Mode	
9	9 Ø71		ESC Ø33	O 117	y 171		9 Ø71		ESC ? Ø33 Ø77	y 171
-	-(minus) Ø55		ESC Ø33	O 117	m 155		-(minus) † Ø55		ESC ? Ø33 Ø77	m 155 †
,	,(comma) Ø54		ESC Ø33	O 117	l 154		,(comma) † Ø54		ESC ? Ø33 Ø77	l Ø54 †
.	.(period) Ø56		ESC Ø33	O 117	n 156		.(period) Ø56		ESC ? Ø33 Ø77	n 156
ENTER*	CR or Ø15	CR Ø15	LF Ø12	ESC Ø33	O 117	M 115	CR or CR Ø15 Ø15	LF Ø12	ESC ? Ø33 Ø77	M 115
PF1	ESC Ø33	O 117	P 12Ø	ESC Ø33	O 117	P 12Ø	ESC Ø33	P 12Ø	ESC ? Ø33 Ø77	P 12Ø
PF2	ESC Ø33	O 117	Q 121	ESC Ø33	O 117	Q 121	ESC Ø33	Q 121	ESC ? Ø33 Ø77	Q 121
PF3	ESC Ø33	O 117	R 122	ESC Ø33	O 117	R 122	ESC Ø33	R 122	ESC ? Ø3 Ø77	R 122
PF4	ESC Ø33	O 117	S 123	ESC Ø33	O 117	S 123	ESC Ø33	S † 123	ESC ? Ø33 Ø77	S † 123

\* When numeric keypad mode is selected (alternate keypad mode off), the ENTER character code can be changed by the line feed/new line feature. When off, this feature causes ENTER to generate a single control character (CR, octal Ø15). When on, this feature causes ENTER to generate two characters (CR, octal Ø15 and LF, octal Ø12).

† These sequences were not available in the VT52. Do not use the PF4, "-" (minus), or "," (comma) keys with VT52 software.

CHAPTER 4  
RECEIVED CHARACTER PROCESSING

**GENERAL**

This chapter describes the terminal's response to received data. Most of the data are displayable characters that appear on the screen with no other effect. But a type of data called control functions has important effects on the operation of the terminal.

A control function is one or more character codes that provide control of the transmission, processing, and display of characters. Control functions command the VT125 to change its operations, for example, by controlling and commanding graphics protocols, changing its response to other control functions, erasing parts of the screen, ringing the bell, or selecting character sets. The VT125 can also transmit control functions to the computer, either with special keys or at the request of the computer.

This chapter explains the implementation of control functions using control characters, escape sequences, control sequences, and device control strings. This implementation is explained according to the standards created by the American National Standards Institute (ANSI) and the International Organization for Standardization (ISO). The words used are defined, and all the control functions that the VT125 understands are listed and explained. For VT125 features that do not have an ANSI standard control function, DEC private control functions have been defined within the extensions permitted by the ANSI standards. A detailed explanation of the format of ANSI control functions is in Appendix E.

Each control function has a unique name, and each name has a unique abbreviation. The name and abbreviation are standardized. The abbreviation is derived from the name to help the programmer remember its meaning, and so it is also called a mnemonic. This book lists the mnemonic with the control function name to help the programmer.

**ERRORS**

A control function that is not understood by the VT125 is ignored. Unsupported control functions (any sequences that meet ANSI specifications but are not listed in this book) are generally ignored but may produce unexpected responses.

If a control character appears in the middle of a sequence (including the device control strings of the graphics processor), the VT125 uses these rules:

- XON and XOFF always function as defined in the communications chapter.
- ESC, CAN, and SUB always stop a control function in process without consideration of which device was receiving the control function. NUL and DEL are fill characters when received by the terminal.
- Any other control characters are understood as part of the sequence that they are in. If the communication data paths in the VT125 are set to pass the control sequence to another device such as the VT100 or the auxiliary port, any control characters in the control sequence also pass to the other device. Both the text terminal and the graphics processor understand a control character inside a control sequence as if the control character arrived before the control sequence. (The graphics processor ignores these other control characters.)
- Any control characters or control sequences received inside a device control string introducer (DCS) / string terminator (ST) pair is passed to the process or device that was selected by the last DCS, except that no DCS or ST that is understood as a data path control switch is passed to another device or process. The graphics processor ignores a DCS inside a DCS/ST pair.

#### ASCII TABLE AND RECEIVED CHARACTERS

The VT125 terminal processes characters according to the codes shown in the ASCII table (Table 4-1). The ASCII table is a part of the ANSI standards. It is the American Standard Code for Information Interchange (ASCII) and is also ISO Standard 646 and CCITT (Consultive Committee for International Telephone and Telegraph) Alphabet 5. Table 4-1 shows each character with its binary, octal, decimal, and hexadecimal values. The table is 8 columns wide and 16 rows long. This arrangement allows binary relationships between characters. For example, lower case and upper case letters differ only by the value of bit 6.

The VT125 processes a received character based on the type of character as defined by ANSI. Control characters (see next section) are all in the first two columns of the table (except Delete). All other characters are displayable characters with the exception of Space (SP). SP can be considered either an information separator or a displayable character.

#### DISPLAYABLE CHARACTERS

Displayable characters are characters that are displayed on the screen when received. The character displayed on the screen depends on the character set selection. The character set is selected using control functions. Refer to the Character Set

Table 4-1 ASCII Table

BITS				0 0		0 0 1		0 1 0		0 1 1		1 0 0		1 0 1		1 1 0		1 1 1		
B7	B6	B5	ROW	COLUMN		1		2		3		4		5		6		7		
B4	B3	B2	B1	0	1	1	2	3	4	5	6	7	8	9	A	B	C	D	E	
0	0	0	0	0	NUL	00	DLE	20	SP	40	0	60	@	100	P	120	`	140	p	160
				0	00	10	16	20	32	40	48	60	64	80	120	96	140	112	160	
				0	00	10	16	20	32	40	48	60	64	80	120	96	140	112	160	
0	0	0	1	1	SOH	11	DC1 (XON)	21	!	41	1	61	A	101	Q	121	a	141	q	161
				1	11	11	17	21	33	41	49	61	65	81	121	97	141	113	161	
				1	11	11	17	21	33	41	49	61	65	81	121	97	141	113	161	
0	0	1	0	2	STX	22	DC2	22	"	42	2	62	B	102	R	122	b	142	r	162
				2	22	18	22	12	34	42	50	62	66	82	122	82	142	114	162	
				2	22	18	22	12	34	42	50	62	66	82	122	82	142	114	162	
0	0	1	1	3	ETX	33	DC3 (XOFF)	23	#	43	3	63	C	103	S	123	c	143	s	163
				3	33	19	23	13	35	43	51	63	67	83	123	83	143	115	163	
				3	33	19	23	13	35	43	51	63	67	83	123	83	143	115	163	
0	1	0	0	4	EOT	44	DC4	24	\$	44	4	64	D	104	T	124	d	144	t	164
				4	44	20	24	14	36	44	52	64	68	84	124	84	144	116	164	
				4	44	20	24	14	36	44	52	64	68	84	124	84	144	116	164	
0	1	0	1	5	ENQ	55	NAK	25	%	45	5	65	E	105	U	125	e	145	u	165
				5	55	21	25	15	37	45	53	65	69	85	125	85	145	117	165	
				5	55	21	25	15	37	45	53	65	69	85	125	85	145	117	165	
0	1	1	0	6	ACK	66	SYN	26	&	46	6	66	F	106	V	126	f	146	v	166
				6	66	22	26	16	38	46	54	66	70	86	126	86	146	118	166	
				6	66	22	26	16	38	46	54	66	70	86	126	86	146	118	166	
0	1	1	1	7	BEL	77	ETB	27	/	47	7	67	G	107	W	127	g	147	w	167
				7	77	23	27	17	39	47	55	67	71	87	127	87	147	119	167	
				7	77	23	27	17	39	47	55	67	71	87	127	87	147	119	167	
1	0	0	0	8	BS	108	CAN	30	(	50	8	70	H	110	X	130	h	150	x	170
				8	88	24	30	18	40	50	58	70	72	88	130	88	150	120	170	
				8	88	24	30	18	40	50	58	70	72	88	130	88	150	120	170	
1	0	0	1	9	HT	119	EM	31	)	51	9	71	I	111	Y	131	i	151	y	171
				9	99	25	31	19	41	51	59	71	73	89	131	89	151	121	171	
				9	99	25	31	19	41	51	59	71	73	89	131	89	151	121	171	
1	0	1	0	10	LF	1210	SUB	32	*	52	:	72	J	112	Z	132	j	152	z	172
				10	12	26	32	20	42	52	60	72	74	90	132	90	152	122	172	
				10	12	26	32	20	42	52	60	72	74	90	132	90	152	122	172	
1	0	1	1	11	VT	1311	ESC	33	+	53	;	73	K	113	[	133	k	153	{	173
				11	13	27	33	21	43	53	61	73	75	91	133	91	153	123	173	
				11	13	27	33	21	43	53	61	73	75	91	133	91	153	123	173	
1	1	0	0	12	FF	1412	FS	34	,	54	<	74	L	114	\	134	l	154		174
				12	14	28	34	22	44	54	62	74	76	92	134	92	154	124	174	
				12	14	28	34	22	44	54	62	74	76	92	134	92	154	124	174	
1	1	0	1	13	CR	1513	GS	35	-	55	=	75	M	115	]	135	m	155	}	175
				13	15	29	35	23	45	55	63	75	77	93	135	93	155	125	175	
				13	15	29	35	23	45	55	63	75	77	93	135	93	155	125	175	
1	1	1	0	14	SO	1614	RS	36	.	56	>	76	N	116	^	136	n	156	~	176
				14	16	30	36	24	46	56	64	76	78	94	136	94	156	126	176	
				14	16	30	36	24	46	56	64	76	78	94	136	94	156	126	176	
1	1	1	1	15	SI	1715	US	37	/	57	?	77	O	117	_	137	o	157	DEL	177
				15	17	31	37	25	47	57	65	77	79	95	137	95	157	127	177	
				15	17	31	37	25	47	57	65	77	79	95	137	95	157	127	177	

KEY

ASCII CHARACTER	ESC	33	OCTAL
		27	DECIMAL
		1B	HEX

MA-7246

Selection section of this chapter for more information about character sets.

### Control Characters Received

A control character is a single character which, when received by the terminal, starts, modifies or stops a control function. The value of a control character is in the octal range of 0 through 37 and 177.

The control characters that the VT125 understands are shown in Table 4-2 and described in the following paragraphs. All other control codes are ignored by the VT125.

### SEQUENCES

The VT125 is an upward and downward software compatible terminal; that is, previous DEC video terminals have DEC private standards for escape sequences. The VT125 is compatible with both the previous DEC standard and the ANSI standards. Customers may use existing DEC software designed around the VT52 or new VT125 software. The VT125 has a "VT52 compatible" mode in which it responds to escape sequences like a VT52.

Throughout this section of the manual references will be made to "VT52 mode" or "ANSI mode". These two terms are used to indicate the VT125's software compatibility. All new software should be designed around the VT125 "ANSI mode". (All graphics software must use ANSI mode.) Future DIGITAL video terminals will not be committed to VT52 compatibility.

All of the following escape and control sequences are transmitted from the computer to the VT125 unless otherwise noted. All of the escape sequences are a subset of those specified in ANSI X3.64-1979 and ANSI X3.41-1974.

Figure 4-1 (at the end of the chapter) is a one-page summary of the ANSI mode display control functions. These control functions directly or indirectly affect the way the screen looks.

A summary of all control functions is in Appendix C.

### ANSI SEQUENCES

#### 1 SET-UP FEATURE AND MODE SELECTION

SET-UP features are terminal characteristics that can be controlled from the keyboard and stored in the user permanent SET-UP feature memory. Some SET-UP features can also be changed from the computer, but the computer cannot store them in the user permanent memory. Some SET-UP features are terminal modes. Table 4-3 lists the VT125 SET-UP features and modes.

A mode is a state of the terminal that affects the operation of the terminal or how the terminal understands or transmits data. Modes are selected by either the computer or the operator. The terminal stays in a mode until the computer or operator changes the mode setting.



Table 4-2 Control Characters Recognized by VT125

Control Character Mnemonic	Octal Code	Name	Action Taken
NUL	000	Null.	Ignored on input (not stored in input buffer; see full duplex protocol).
ENQ	005	Enquire.	Transmit answerback message.
BEL	007	Bell.	Sounds the bell.
BS	010	Backspace.	Moves the cursor to the left one character position. If it is at the left margin, it stays there.
HT	011	Horizontal Tab	Moves the cursor to the next tab stop, or to the right margin if there are no more tab stops in the line.
LF	012	Line Feed.	Causes a line feed or a new line operation. (See Linefeed/New Line mode).
VT	013	Vertical Tab	Understood as LF.
FF	014	Form Feed.	Understood as LF.
CR	015	Carriage Return	Moves the cursor to the left margin on the current line.
SO	016	Shift Out.	Select G1 character set, as designated by a Select Character Set sequence .
SI	017	Shift In.	Select G0 character set, as designated by a Select Character Set sequence.
DC1	021	Device Control 1	Understood as XON. Lets terminal continue transmission after XOFF.
DC3	023	Device Control 3	Understood as XOFF. Tells terminal to stop transmitting all characters except XOFF and XON.
CAN	030	Cancel.	If received during an escape or control sequence, cancels the sequence and displays the substitution character. Any

Table 4-2 Control Characters Recognized by VT125

Control Character Mnemonic	Octal Name Code		Action Taken
			characters from the sequence that follow the cancel character are displayed after the substitution character.
SUB	032	Substitute.	Understood as CAN.
ESC	033	Escape.	Understood as introducer of an escape sequence.
DEL	177	Delete.	Ignored on input (not stored in input buffer).

Table 4-3 SET-UP Features and Terminal Modes

SET-UP Feature or Terminal Mode	Changeable from Computer*	Changeable in SET-UP and Stored in NVR
Alternate keypad mode	Yes (DECKPAM)	No
ANSI/VT52 mode	Yes (DECANM)	Yes
Auto Repeat mode	Yes (DECARM)	Yes
Autowrap mode	Yes (DECAWM)	Yes
AUTO XON XOFF	No	Yes
Bits per character	No	Yes
Column mode (Char/line)	Yes (DECCOLM)	Yes
Cursor	No	Yes
Cursor keys mode	Yes (DECCKM)	No
Keyclick	No	Yes
Linefeed/New Line mode	Yes (LNM)	Yes
Margin bell	No	Yes
Numeric Keypad mode	Yes (DECKPNM)	No
Origin mode	Yes (DECOM)	No
Parity	No	Yes
Parity sense	No	Yes
Power	No	Yes
Auxiliary Port Bits per char	No	Yes
Auxiliary Port Speed	No	Yes
Receive speed	No	Yes
Screen mode	Yes (DECSCNM)	Yes
Scroll mode	Yes (DECSCLM)	Yes
Tabs	Yes (HTS/TBC)	Yes
Transmit speed	No	Yes
US/UK Char Set	Yes	Yes

\* The control or escape sequence mnemonic that applies is indicated in parentheses.

Modes may be changed with the set mode (SM) and reset mode (RM) commands, except for Keypad Numeric and Application modes. (These modes are changed using dedicated sequences.) Multiple parameters may be included in a single command.

NOTE: The Ps character indicates a parameter selected from a list of parameters. Each parameter listed represents a mode. When setting several modes using a single SM or RM sequence, the parameters are separated by a semicolon (octal 073). The semicolon is not used when selecting only one mode.

#### Set Mode Command - SM

Format: ESC [ Ps;...;Ps h default value: none

Causes one or more modes to be set within the VT125 as specified by each parameter in the parameter string. Each mode to be set is specified by a separate parameter. A mode is considered set until it is reset by a reset mode (RM) control sequence or in SET-UP.

#### Reset Mode Command - RM

Format: ESC [ Ps;...;Ps l default value: none

Resets one or more VT125 modes as specified by each parameter in the parameter string. Each mode to be reset is specified by a separate parameter.

The following is a list of VT125 modes that may be changed with Set Mode and Reset Mode.

#### ANSI Specified Modes

Parameter	Mode Function	Mode Mnemonic
0	Error (ignored)	
20	Auto Linefeed/New Line mode	LNLM

#### DEC Private Modes

NOTE: The first character in the DEC private parameter string is ? (77(8)). The parameters are understood according to Table 4-4. Any other parameter values are ignored.

NOTE: Keypad Application Mode (DECKPAM) and Keypad Numeric Mode (DECKNM) are changed using two special two-character sequences; not the usual Set and Reset Mode sequences.

Table 4-4 DEC Private Modes

Parameter	Mode Function	Mode Mnemonic
Ø	Error (ignored)	
1	Cursor key	DECCKM
2	ANSI/VT52	DECANM
3	Column	DECCOLM
4	Scrolling	DECSCLM
5	Screen	DECSCNM
6	Origin	DECOM
7	Auto wrap	DECAWM
8	Auto repeating	DECARM

The modes in Table 4-5, which are specified in the ANSI X3.64-1979 standard, may be considered to be permanently set, permanently reset, or not applying, as indicated. Refer to that standard for more information about these modes.

The following modes are listed alphabetically by name (see Table 4-3).

ANSI/VT52 Mode (DEC Private) -- DECANM

This mode changes the cursor key and auxiliary keypad codes. See Tables 4-6 and 4-8. This mode must be set to ANSI or the graphics processor cannot work.

Set: (From VT52 Mode) ESC <

The set state causes only ANSI escape and control sequences to be understood and executed.

Reset: ESC[?21

The reset state causes only VT52 compatible escape sequences to be understood and executed.

Auto Repeat Mode (DEC Private) - DECARM

Set: ESC[?8h

The set state causes keyboard keys to auto-repeat except SET-UP, ENTER, ESC, RETURN, NO SCROLL, and CTRL with any key.

Reset: ESC[?8l

The reset state causes no keyboard keys to auto-repeat.

**Table 4-5 Permanently Selected Modes**

Mode Name	Mode Mnemonic	State
Control representation	CRM	Reset Control functions are performed without displaying a character to represent the control function received.
Editing boundary	EBM	Reset Characters moved outside the margins are lost and erasing and cursor positioning functions are not performed outside the margins.
Erasure	ERM	Set All characters displayed can be erased.
Format effector action	FEAM	Reset Control functions that affect the screen display are performed immediately.
Format effector transfer	FETM	NA
Guarded area transfer	GATM	NA
Horizontal editing	HEM	NA
Insertion-replacement	IRM	Reset Received characters replace the characters at the cursor position.
Keyboard action	KAM	Reset Typed characters are processed except when the keyboard is locked.
Multiple area transfer	MATM	NA
Positioning unit	PUM	Reset Horizontal and vertical parameters in control functions are specified in units of character positions.
Selected area transfer	SATM	NA
Status reporting transfer	SRTM	Reset

**Table 4-5 Permanently Selected Modes (Cont)**

Mode Name	Mode Mnemonic	State
		Status reports are transmitted by the VT125 using the Device Status Report (DSR) sequence.
Tabulation stop	TSM	Reset The tab stop selection apply to the corresponding column of all lines on the screen.
Transfer termination	TTM	NA
Vertical editing	VEM	NA

**Table 4-6 Cursor Control Key Codes**

Cursor Key (arrow)	Cursor Key Mode Reset	Cursor Key Mode Set
Up	ESC [A	ESC O A
Down	ESC [B	ESC O B
Right	ESC [C	ESC O C
Left	ESC [D	ESC O D

Autowrap Mode (DEC Private) - DECAWM

Set: ESC[?7h

The set state causes any displayable characters received when the cursor is at the right margin to advance to the start of the next line, doing a scroll up if needed and if the cursor has not been positioned outside of the scrolling region.

Reset: ESC[?7l

The reset state causes characters received while the cursor is at the right margin to replace any previous characters there.

Column Mode (DEC Private) - DECCOLM

Set: ESC[?3h

The set state causes a maximum of 132 columns on the screen.

**Table 4-7 Linefeed/Newline Mode**

Linefeed/ New Line Mode	Key Pressed	Code Sent
RESET	RETURN	CR
RESET	LINEFEED	LF
SET	RETURN	CR LF
SET	LINEFEED	LF
Linefeed/ New Line Mode	Code Received	Action Taken
RESET	CR	Return
RESET	LF	Linefeed
SET	CR	Return
SET	LF	Return - Linefeed

Reset: ESC[?31

The reset state causes a maximum of 80 columns on the screen.

**Cursor Keys Mode (DEC Private) - DECCKM**

This mode only has effect when the terminal is in ANSI mode. Table 4-6 shows the sequences generated by each key.

Set: ESC[?1h

The four cursor keys send application control functions.

Reset: ESC[?11

The four cursor keys send ANSI cursor control commands.

**Linefeed/New Line Mode - LNM**

This mode does not affect Index or Next Line. See Table 4-7.

Set: ESC[20h

The set state causes received line feed (LF) to move the active position to the first position of the following line and causes the return key (CR) to send the two codes (CR, LF).

Reset: ESC[201

The reset state causes line feed to move the active position down only, and causes the return key to send the single code CR.

These are characters displayed using 80 columns.

MA-6672

These are characters displayed using 132 columns.

MA-6671



**Table 4-8 ANSI Mode Auxiliary Keypad Codes**

Key	Keypad Numeric Mode	Keypad Application Mode
Ø	Ø	ESC O p
1	1	ESC O q
2	2	ESC O r
3	3	ESC O s
4	4	ESC O t
5	5	ESC O u
6	6	ESC O v
7	7	ESC O w
8	8	ESC O x
9	9	ESC O y
-(minus)	-(minus)	ESC O m
,(comma)	,(comma)	ESC O l
.(period)	.(period)	ESC O n
ENTER	Same as RETURN key	ESC O M
PF1	ESC O P	ESC O P
PF2	ESC O Q	ESC O Q
PF3	ESC O R	ESC O R
PF4	ESC O S	ESC O S

**Keypad Application Mode (DEC Private) - DECKPAM**

Format: ESC =

The auxiliary keypad keys and cursor control keys transmit escape sequences. Table 4-8 lists the sequences.

**Keypad Numeric Mode (DEC Private) - DECKPNM**

Format: ESC >

The auxiliary keypad keys send ASCII codes corresponding to the characters on the keys (except for the PF keys and enter). The cursor control keys send cursor controls. Table 4-8 lists the sequences.

NOTE: In ANSI mode, if the codes are echoed back to the VT125, or if the terminal is LOCAL, the last character of the sequence is displayed on the screen; for example, PF1 is displayed as a "P". See SS2 and SS3 in Character Sets and Selection.

**Origin Mode (DEC Private) - DECOM**

Lines and columns are numbered consecutively, with the origin being line 1, column 1. The cursor is moved to the new home position when this mode is set or reset.

Set: ESC[?6h

The set state causes the origin to be at the upper-left character position within the margins of the scrolling region (see Scrolling). This is the Home position when Origin Mode is set. Line numbers are relative to the current margin settings. For example, if the top margin is line 5, the top line is addressed as line 1 for cursor positioning. (Home position is therefore line 5, column 1, absolute.) The cursor is not allowed to be positioned outside the margins.

Reset: ESC[?6l

DECSCNM-SCREEN

 REVERSE ESC [?5h  
(BLACK-ON-WHITE)

 NORMAL ESC [?5l  
(WHITE-ON-BLACK)

The reset state causes the origin to be at the upper-left character position on the screen. This is the Home position when Origin Mode is reset. Line numbers are not affected by the current margin settings. The cursor may be positioned outside the margins with a Cursor Position or Horizontal and Vertical Position control sequence.

Screen Mode (DEC Private) - DECSCNM

Set: ESC[?5h

The set state causes the screen to be white with black characters.

Reset: ESC[?5l

The reset state causes the screen to be black with white characters.

Scrolling Mode (DEC Private) - DECSCLM

Set: ESC[?4h

The set state causes smooth scrolling at a maximum rate of six lines per second.

Reset: ESC[?4l

The reset state causes jump scrolling.

**Select Character Sets - SCS**

The VT125 text mode can display 94 characters (one character set) at a time without using control functions. But by using control functions to select the character sets, the VT125 can display more than 94 different characters on the screen by storing characters in up to five different character sets (some characters appear in more than one character set). The VT125 character sets are:

- United States character set
- United Kingdom character set
- Special characters and line drawing character set
- Alternate ROM standard character set
- Alternate ROM Special characters

NOTE: The Alternate ROM is an optional feature of the VT100 terminal controller board that allows two more character sets to be resident in the terminal, as compared with the graphics processor character sets which must be loaded for use. Refer to the VT100 Series Technical Manual for the specifications of this ROM.

Tables 4-9 through 4-11 show the three standard VT125 character sets. Notice that the control characters and the Space and Delete characters are the same in all character sets.

Any two of the VT125 character sets can be considered active at any one time. They can be invoked (selected) with single-character control functions if they are first designated by multiple character escape sequences. The two active character sets are designated by the computer as G0 and G1 using the Select Character Set (SCS) escape sequence. Once the character sets are designated by the computer, a single control character is used to switch between the character sets. The Shift In (SI, octal 017) control character invokes the G0 character set. The Shift Out (SO, 016) control character invokes the G1 character set.

The designated character sets are active until another Select Character Set (SCS) sequence is received. The G0 and G1 character sets can be redesignated by the computer as often as needed using the SCS sequence. The following sequences designate the VT125 G0 character set:

Name	Mnemonic	Sequence
Select Character Set	SCS ESC ( A	Designate the United Kingdom character set as G0
Select Character Set	SCS ESC ( B	Designate the United States character set as G0

Table 4-9 U.K. Character Set

BITS				0 0		0 0 1		0 1 0		0 1 1		1 0 0		1 0 1		1 1 0		1 1 1			
B7	B6	B5	ROW	COLUMN		0		1		2		3		4		5		6		7	
B4	B3	B2	B1	0		1		2		3		4		5		6		7			
0	0	0	0	0	NUL	0		20	SP	40	0	60	@	100	P	120	`	140	p	160	
				0		0		16		32		48		64		80		96		112	
				0		0		10		20		30		40		50		60		70	
0	0	0	1	1		DC1 (XON)	21	!	41	1	61	A	101	Q	121	a	141	q	161		
				1			17		33		49		65		81		97		113		
				1			11		21		31		41		51		61		71		
0	0	1	0	2			22	"	42	2	62	B	102	R	122	b	142	r	162		
				2			18		34		50		66		82		98		114		
				2			12		22		32		42		52		62		72		
0	0	1	1	3		DC3 (XOFF)	23	£	43	3	63	C	103	S	123	c	143	s	163		
				3			19		35		51		67		83		99		115		
				3			13		23		33		43		53		63		73		
0	1	0	0	4			24	\$	44	4	64	D	104	T	124	d	144	t	164		
				4			20		36		52		68		84		100		116		
				4			14		24		34		44		54		64		74		
0	1	0	1	5	ENQ		25	%	45	5	65	E	105	U	125	e	145	u	165		
				5			21		37		53		69		85		101		117		
				5			15		25		35		45		55		65		75		
0	1	1	0	6			26	&	46	6	66	F	106	V	126	f	146	v	166		
				6			22		38		54		70		86		102		118		
				6			16		26		36		46		56		66		76		
0	1	1	1	7	BEL		27	,	47	7	67	G	107	W	127	g	147	w	167		
				7			23		39		55		71		87		103		119		
				7			17		27		37		47		57		67		77		
1	0	0	0	8	BS	CAN	30	(	50	8	70	H	110	X	130	h	150	x	170		
				8			24		40		56		72		88		104		120		
				8			18		28		38		48		58		68		78		
1	0	0	1	9	HT		31	)	51	9	71	I	111	Y	131	i	151	y	171		
				9			25		41		57		73		89		105		121		
				9			19		29		39		49		59		69		79		
1	0	1	0	10	LF	SUB	32	*	52	:	72	J	112	Z	132	j	152	z	172		
				10			26		42		58		74		90		106		122		
				10			1A		2A		3A		4A		5A		6A		7A		
1	0	1	1	11	VT	ESC	33	+	53	;	73	K	113	[	133	k	153	{	173		
				11			27		43		59		75		91		107		123		
				11			1B		2B		3B		4B		5B		6B		7B		
1	1	0	0	12	FF		34	,	54	<	74	L	114	\	134	l	154		174		
				12			28		44		60		76		92		108		124		
				12			1C		2C		3C		4C		5C		6C		7C		
1	1	0	1	13	CR		35	-	55	=	75	M	115	]	135	m	155	}	175		
				13			29		45		61		77		93		109		125		
				13			1D		2D		3D		4D		5D		6D		7D		
1	1	1	0	14	SO		36	.	56	>	76	N	116	^	136	n	156	~	176		
				14			30		46		62		78		94		110		126		
				14			1E		2E		3E		4E		5E		6E		7E		
1	1	1	1	15	SI		37	/	57	?	77	O	117	_	137	o	157	DEL	177		
				15			31		47		63		79		95		111		127		
				15			1F		2F		3F		4F		5F		6F		7F		

KEY

ASCII CHARACTER

ESC	33	OCTAL
	27	DECIMAL
	1B	HEX

MA-7248

Table 4-10 U.S. Character Set

BITS		0 0		0 0 1		0 1 0		0 1 1		1 0 0		1 0 1		1 1 0		1 1 1	
B7 B6 B5		0 0		0 0 1		0 1 0		0 1 1		1 0 0		1 0 1		1 1 0		1 1 1	
B4 B3 B2 B1		0		1		2		3		4		5		6		7	
ROW		0		1		2		3		4		5		6		7	
0 0 0 0	0	NUL	0 0		20 16 10	SP	40 32 20	0	60 48 30	@	100 64 40	P	120 80 50	`	140 96 60	p	160 112 70
0 0 0 1	1		1 1 1	DC1 (XON)	21 17 11	!	41 33 21	1	61 49 31	A	101 65 41	Q	121 81 51	a	141 97 61	q	161 113 71
0 0 1 0	2		2 2 2		22 18 12	"	42 34 22	2	62 50 32	B	102 66 42	R	122 82 52	b	142 98 62	r	162 114 72
0 0 1 1	3		3 3 3	DC3 (XOFF)	23 19 13	#	43 35 23	3	63 51 33	C	103 67 43	S	123 83 53	c	143 99 63	s	163 115 73
0 1 0 0	4		4 4 4		24 20 14	\$	44 36 24	4	64 52 34	D	104 68 44	T	124 84 54	d	144 100 64	t	164 116 74
0 1 0 1	5	ENQ	5 5 5		25 21 15	%	45 37 25	5	65 53 35	E	105 69 45	U	125 85 55	e	145 101 65	u	165 117 75
0 1 1 0	6		6 6 6		26 22 16	&	46 38 26	6	66 54 36	F	106 70 46	V	126 86 56	f	146 102 66	v	166 118 76
0 1 1 1	7	BEL	7 7 7		27 23 17	'	47 39 27	7	67 55 37	G	107 71 47	W	127 87 57	g	147 103 67	w	167 119 77
1 0 0 0	8	BS	8 8 8	CAN	30 24 18	(	50 40 28	8	70 56 38	H	110 72 48	X	130 88 58	h	150 104 68	x	170 120 78
1 0 0 1	9	HT	9 9 9		31 25 19	)	51 41 29	9	71 57 39	I	111 73 49	Y	131 89 59	i	151 105 69	y	171 121 79
1 0 1 0	10	LF	12 10 A	SUB	32 26 1A	*	52 42 2A	:	72 58 3A	J	112 74 4A	Z	132 90 5A	j	152 106 6A	z	172 122 7A
1 0 1 1	11	VT	13 11 B	ESC	33 27 1B	+	53 43 2B	;	73 59 3B	K	113 75 4B	[	133 91 5B	k	153 107 6B	{	173 123 7B
1 1 0 0	12	FF	14 12 C		34 28 1C	,	54 44 2C	<	74 60 3C	L	114 76 4C	\	134 92 5C	l	154 108 6C		174 124 7C
1 1 0 1	13	CR	15 13 D		35 29 1D	-	55 45 2D	=	75 61 3D	M	115 77 4D	]	135 93 5D	m	155 109 6D	}	175 125 7D
1 1 1 0	14	SO	16 14 E		36 30 1E	.	56 46 2E	>	76 62 3E	N	116 78 4E	^	136 94 5E	n	156 110 6E	~	176 126 7E
1 1 1 1	15	SI	17 15 F		37 31 1F	/	57 47 2F	?	77 63 3F	O	117 79 4F	_	137 95 5F	o	157 111 6F	DEL	177 127 7F

KEY

ASCII CHARACTER	ESC	33	OCTAL
		27	DECIMAL
		1B	HEX

MA 7247

Table 4-11 Special Character and Line Drawing Character Set

BITS		0 0		0 0 1		0 1 0		0 1 1		1 0 0		1 0 1		1 1 0		1 1 1			
B7 B6 B5		COLUMN		1		2		3		4		5		6		7			
B4	B3	B2	B1	0		1		2		3		4		5		6		7	
ROW				0		1		2		3		4		5		6		7	
0	0	0	0	0	NUL	0	20	0	SP	0	60	0	@	0	P	0	↑	0	-
				0	0	16	10	40	32	60	48	100	64	120	80	140	96	160	112
				0	0	10	10	20	20	30	30	40	40	50	50	60	60	70	70
0	0	0	1	1	DC1 (XON)	21	17	41	33	61	49	101	65	121	81	141	97	161	113
				1	1	11	11	21	21	31	31	41	41	51	51	61	61	71	71
0	0	1	0	2		22	18	42	34	62	50	102	66	122	82	142	98	162	114
				2	2	12	12	22	22	32	32	42	42	52	52	62	62	72	72
0	0	1	1	3	DC3 (XOFF)	23	19	43	35	63	51	103	67	123	83	143	99	163	115
				3	3	13	13	23	23	33	33	43	43	53	53	63	63	73	73
0	1	0	0	4		24	20	44	36	64	52	104	68	124	84	144	100	164	116
				4	4	14	14	24	24	34	34	44	44	54	54	64	64	74	74
0	1	0	1	5	ENQ	25	21	45	37	65	53	105	69	125	85	145	101	165	117
				5	5	15	15	25	25	35	35	45	45	55	55	65	65	75	75
0	1	1	0	6		26	22	46	38	66	54	106	70	126	86	146	102	166	118
				6	6	16	16	26	26	36	36	46	46	56	56	66	66	76	76
0	1	1	1	7	BEL	27	23	47	39	67	55	107	71	127	87	147	103	167	119
				7	7	17	17	27	27	37	37	47	47	57	57	67	67	77	77
1	0	0	0	8	BS	30	24	50	40	70	56	110	72	130	88	150	104	170	120
				8	CAN	18	18	28	28	38	38	48	48	58	58	68	68	78	78
1	0	0	1	9	HT	31	25	51	41	71	57	111	73	131	89	151	105	171	121
				9	9	19	19	29	29	39	39	49	49	59	59	69	69	79	79
1	0	1	0	10	LF	32	26	52	42	72	58	112	74	132	90	152	106	172	122
				10	SUB	1A	1A	2A	2A	3A	3A	4A	4A	5A	5A	6A	6A	7A	7A
1	0	1	1	11	VT	33	27	53	43	73	59	113	75	133	91	153	107	173	123
				11	ESC	1B	1B	2B	2B	3B	3B	4B	4B	5B	5B	6B	6B	7B	7B
1	1	0	0	12	FF	34	28	54	44	74	60	114	76	134	92	154	108	174	124
				12	12	1C	1C	2C	2C	3C	3C	4C	4C	5C	5C	6C	6C	7C	7C
1	1	0	1	13	CR	35	29	55	45	75	61	115	77	135	93	155	109	175	125
				13	13	1D	1D	2D	2D	3D	3D	4D	4D	5D	5D	6D	6D	7D	7D
1	1	1	0	14	SO	36	30	56	46	76	62	116	78	136	94	156	110	176	126
				14	14	1E	1E	2E	2E	3E	3E	4E	4E	5E	5E	6E	6E	7E	7E
1	1	1	1	15	SI	37	31	57	47	77	63	117	79	137	95	157	111	177	127
				15	15	1F	1F	2F	2F	3F	3F	4F	4F	5F	5F	6F	6F	7F	7F

KEY

ASCII CHARACTER	ESC	33	OCTAL
		27	DECIMAL
		1B	HEX

MA-7249

Name	Mnemonic	Sequence
Select Character Set	SCS ESC ( 0	Designate the special character and line drawing character set as G0
Select Character Set	SCS ESC ( 1	Designate the Alternate ROM standard character set as G0
Select Character Set	SCS ESC ( 2	Designate the Alternate ROM special character and line drawing set as G0

The following sequences designate the VT125 G1 character set:

Name	Mnemonic	Sequence
Select Character Set	SCS ESC ) A	Designate the United Kingdom character set as G1
Select Character Set	SCS ESC ) B	Designate the United States character set as G1
Select Character Set	SCS ESC ) 0	Designate the special character and line drawing character set as G1
Select Character Set	SCS ESC ) 1	Designate the Alternate ROM standard character set as G1
Select Character Set	SCS ESC ) 2	Designate the Alternate ROM special character and line drawing set as G1

The VT125 terminal also has a G2 and G3 character set. However, these character sets are always the United States (ASCII) character set. The G2 and G3 character sets can be selected for only one character at a time. The G2 and G3 character sets are selected using the single shift 2 (SS2) and single shift 3 (SS3) sequences. The terminal returns to the previously used character set after a single character is displayed. Select the G2 and G3 character sets for one character using the following sequences.

Name	Mnemonic	Sequence	Function
Single Shift 2	SS2	ESC N 033 115	Selects the G2 (ASCII) character set for one character.
Single Shift 3	SS3	ESC O 033 117	Selects the G3 (ASCII) character set for one character.

The United States and United Kingdom sets conform to the "ISO international register of character sets to be used with escape sequences". The other sets are private character sets. Special graphics means that the graphic characters for the codes 137(8) to 176(8) are replaced with other characters. The specified character set will be invoked by SI or SO until another SCS is received. Table 4-9 lists the U.S. character set, Table 4-10 lists the U.K. character set, and Table 4-11 lists the special character and line drawing character set. The VT125's U.S. character set is a subset of the ASCII character set because in the VT125, only a few of the ASCII control characters have displayable forms.



NOTE: The character set selected by SCS is only used by the text terminal. The graphics processor selects character sets with a ReGIS command.

### Select Graphic Rendition - SGR

Format: ESC [ Pn m default value: 0

In the VT125, this turns on the character attributes, which are special display features that can be used (along with line attributes like double width) to make text on the screen appear special. All characters transmitted to the VT125 after the SGR sequence are displayed with the selected attributes until the next SGR sequence clears or changes the attributes.

Name	Mnemonic	Sequence	Meaning
Select Graphic Rendition	SGR	ESC [ 0 m	Attributes off
Select Graphic Rendition	SGR	ESC [ 1 m	Bold or increased intensity
Select Graphic Rendition	SGR	ESC [ 4 m	Underline
Select Graphic Rendition	SGR	ESC [ 5 m	Blink
Select Graphic Rendition	SGR	ESC [ 7 m	Negative (reverse) image

 SGR OFF ESC[0m  
 UNDERSCORE ESC[4m  
 REVERSE ESC[7m (BLACK-ON-WHITE)  
 ↑ DEPENDS ON CURSOR

All other parameter values are ignored.

Without the Advanced Video Option, a character can have only one attribute, and the attribute can only be underline or reverse.



Either 4 or 7 can be used in the control sequence, but the VT125 interprets the parameter as whichever attribute has been selected for the cursor in SET-UP. (See cursor selection in the SET-UP chapter.)

### 3 SCROLLING

#### Scrolling Region

The scrolling region is the area of the screen that can receive new characters by scrolling old characters off the screen either up or down. This area is defined by the top and bottom screen margins. The minimum size of the scrolling region allowed is two lines, so the number of the top margin must be at least 2 less than the number of the bottom margin. The cursor moves to the home position when the margins are set (see Origin Mode in Modes).

Set Top and Bottom Margins (DEC Private) -- DECSTBM

Format: ESC [ Pt; Pb r                      default values: Full Screen

This sequence sets the top and bottom margins to define the scrolling region. Parameter Pt is the line number of the top line in the scrolling region; parameter Pb is the line number of the bottom line in the scrolling region. Default is the complete screen (no margins).

NOTE: Power up or reset causes the scrolling region to be the complete screen.

### 4 CURSOR POSITIONING

The cursor indicates the location of the active position. This is where the next character appears. The cursor always moves one column to the right when a character appears, and moves down one line when the terminal receives a line feed. The cursor moves to the left margin when the terminal receives a carriage return. If a command tries to move the cursor past any margin, the action that will result is stated. The cursor moves to the home position (see Origin mode) when the top and bottom margins of the scrolling region are set and when Origin mode is set or reset. Table 4-12 lists the sequences that move the cursor according to their parameters:

### 5 TABS

Tabs are positions selected on the horizontal lines of the screen. The cursor advances (tabs) to the tab stops when the terminal receives an HT (octal 011) control character. Each control character advances the cursor to the next tab stop. If no tabs are set, any HT character moves the cursor to the right margin.

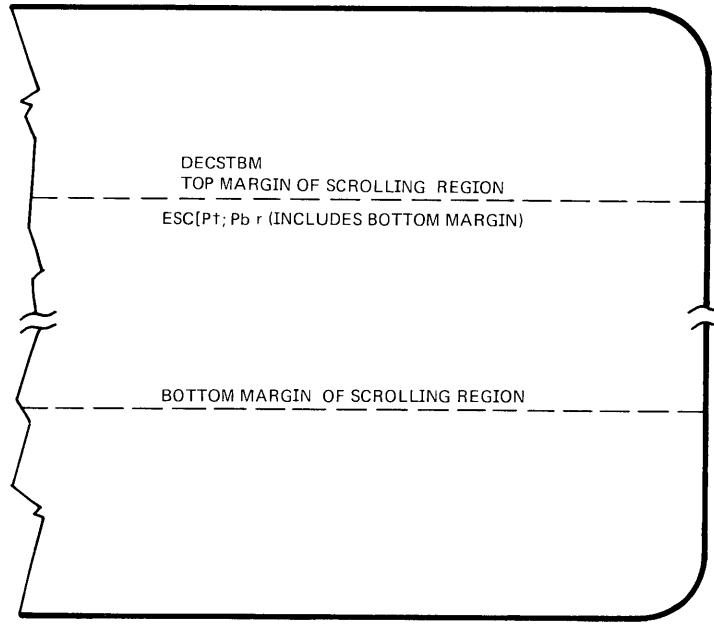

Table 4-12 Cursor Positioning Commands

Command Name Format	Default Value	Mnemonic Function
Cursor Up ESC [ Pn A	1	CUU Moves the cursor Pn lines up in same column. Cursor stops at the top margin.
Cursor Down ESC [ Pn B	1	CUD Moves the cursor down Pn lines in same column. Cursor stops at the bottom margin.
Cursor Forward ESC [ Pn C	1	CUF Moves the cursor Pn columns to the right. Cursor stops at the right margin.
Cursor Backward ESC [ Pn D	1	CUB Moves the cursor Pn columns to the left. Cursor stops at the left margin.
Cursor Position ESC [ Pl ; Pc H	1	CUP Moves the cursor to line Pl, column Pc. Default value for either moves the cursor to the first line or column, respectively; for both, to home. For Pl or Pc outside margins, cursor stops at nearest margin.  The numbering of lines depends on Origin Mode. In the VT125, this control acts like the Horizontal and Vertical Position control.
Horizontal and Vertical Position ESC [ Pl ; Pc f	1	HVP Moves the cursor to line Pl, column Pc. Default value for either moves the cursor to the first line or column, respectively. When the default value is used for both parameters, the cursor moves to home position. For Pl or Pc outside margins, cursor stops at nearest margin.

Table 4-12 Cursor Positioning Commands

Command Name Format	Default Value	Mnemonic Function
		The numbering of lines depends on Origin Mode. In the VT125, this control behaves identically with Cursor Position.
Cursor Position Report ECS [ P1 ; Pc R		CPR Requested by DSR ESC [ 6 n. See the Reports section.
Index ESC D		IND None Moves the cursor down one line in same column. If the cursor is at the bottom margin, a scroll up is performed.
Reverse Index ESC M		RI None Moves the cursor to the same horizontal position on the preceding line. If the cursor is at the top margin, a scroll down is performed.
Next Line ESC E		NEL None Moves cursor to the first position on the next line down. If the cursor is at the bottom margin, a scroll up is performed.
Save Cursor (DEC Private) ESC 7		DECSC None Saves the cursor position, graphic rendition (character attribute), and character set in terminal memory. (See Restore Cursor).
Restore Cursor (DEC Private) ESC 8		DECRC None Restores the previously saved cursor position, graphic rendition (character attribute), and character set. If none was saved the cursor moves to the top left home position (line 1, column 1) regardless of Origin Mode.

## Horizontal Tabulation Set - HTS

Sequence	Meaning
ESC H	Set one horizontal stop at the cursor position.

## Tabulation Clear - TBC

Sequence	Meaning
ESC [ 0 g	Clear the horizontal tab stop at the active position (default).
ESC [ 3 g	Clear all horizontal tab stops.

## 6 LINE ATTRIBUTES

Line attributes are special display features of the VT125 that affect a complete line at a time. Only the line containing the cursor is affected. The cursor stays in the same character position unless it would be to the right of the right margin, in which case it moves to the right margin.

### Double Height Line (DEC Private) - DECDHL

Sequence	Meaning
----------	---------

Top Half: ESC #3  
Bottom Half: ESC #4

DECDHL **AB** TOP HALF ESC #3  
BOTTOM HALF ESC #4

DECDWL **AB** ESC #6

DECSWL **AB** ESC #5

These sequences cause the line including the active position to become the top or bottom half of a double-height double-width line. The sequences must be used in pairs on adjacent lines and the same character output must be sent to both lines to form full double-height characters. If the line was single-width single-height, all characters to the right of the center of the screen are lost.

### Double-Width Line (DEC Private) - DECDWL

Sequence	Meaning
----------	---------

ESC #6

This causes the line that includes the active position to become double-width single-height. If the line was single-width single-height, all characters to the right of the center of the screen are lost.

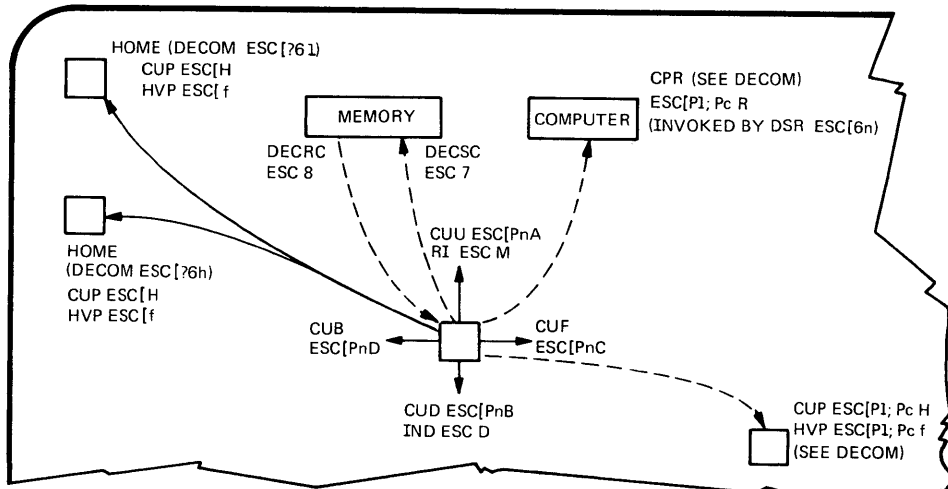

MA-6665

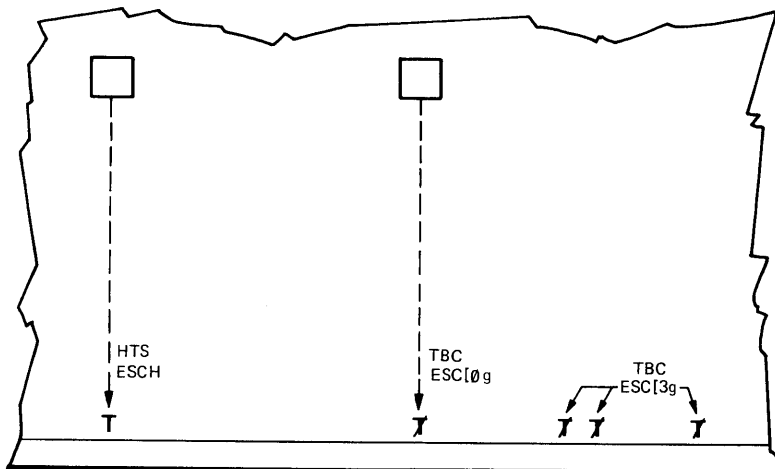

MA-6662

## Single-width Line (DEC Private) - DECSWL

Sequence	Meaning
ESC #5	This causes the line that includes the active position to become single-width single-height. This is the default condition for all new lines on the screen.

## 7 ERASING

Erasing removes characters from the text memory of the VT125. When characters are erased from the text memory, they are lost. Any complete line erased by Erase in Display has its line attribute set to single-height, single-width. Erasing does not change the number of columns per line.

### Erase In Display -- ED

ESC [ Pn J default value: 0

This sequence erases some or all of the characters in the display according to the parameter. Any complete line erased by this sequence is given a line attribute for single-height, single-width.

ESC [ J Erase from the cursor to the end of the screen

ESC [ 0 J Erase from the cursor to the end of the screen

ESC [ 1 J Erase from start of the screen to the cursor

ESC [ 2 J Erase all of the display -- all lines are erased, changed to single-width, and the cursor does not move.

### Erase In Line - EL

ESC [ Pn K default value: 0

Erases some or all characters in the active line according to the parameter. Erasing does not change line attributes.

ESC [ K Erase from the cursor to the end of the line

ESC [ 0 K Erase from the cursor to the end of the line

ESC [ 1 K Erase from the start of the line to the cursor

ESC [ 2 K Erase all of the line



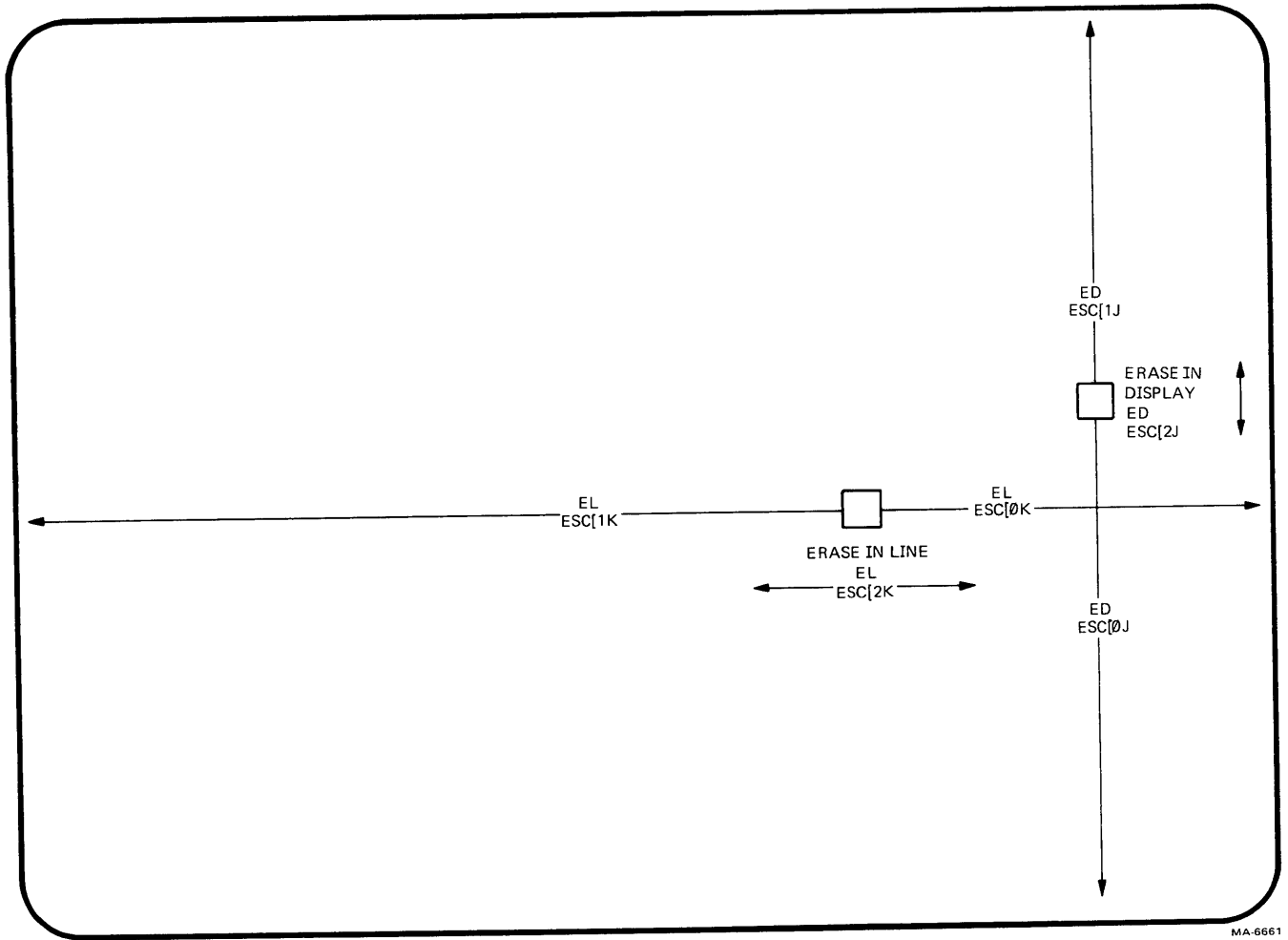

MA-6661

## 8 VT125 COMMUNICATION AND GRAPHICS PROTOCOL CONTROLS

The VT125 uses an ANSI protocol called the Device Control String to control its graphics and some of its communications. A control string is a group of characters that have a clearly marked beginning and end and are understood by a device as a unit for control purposes. The Device Control String is made of an introducer followed by data followed by a terminator. The introducer is two characters (ESC P) that tell the VT125 to understand the characters that follow as parameter information about which graphics protocol is coming (ReGIS, DECwriter, or VT105) and where it should go (to the host, the auxiliary port, or the video screen). The rest of the string is graphics data in the specified protocol, followed by the terminator. The terminator is two characters (ESC ) called the String Terminator, and it returns the VT125 to its text operation. When a device control string begins, the VT125 can not understand another device control string command until the first one is terminated by the String Terminator characters.

Device Control String (Introducer) - DCS

ESC P

Introducer to the commands that control the VT125's internal protocols. When the VT125 receives this sequence from one of its data paths, it looks at that same data path for one or two more characters to select the operation, as listed below. (See Chapter 7 for an explanation of the data paths.)

Device Control String Parameters

ESC P p or ESC P Ø p

Enter ReGIS, accepting data from the same data path as this sequence, at the command level that was in effect at the end of the last ReGIS device control string. (ReGIS is at the highest command level if the terminal was reset after the last device control string.)

ESC P 1 p

Enter ReGIS, accepting data from the same data path as this sequence, and force immediate synchronization to the highest command level in the same way that the ";" character acts in

a ReGIS command string. (The semicolon is explained in the ReGIS chapter.)

ESC P 2 p

Enter ReGIS according to 0 p (allowing completion of previous commands) and also send the ReGIS text to the data path that was previously selected. (This typically is the host to VT100 data path and allows the simultaneous display of both the graphics and the ReGIS text that creates the graphics.)

ESC P 3 p

Enter ReGIS according to 1 p (immediate synchronization) and also send the ReGIS text to the data path that was previously selected. (This typically is the host to VT100 data path and allows the simultaneous display of both the graphics and the ReGIS text that creates the graphics.)

ESC P Pn q - Delimit image format

Accept the text that follows from the same data path as this sequence as DECwriter graphics hard copy descriptor and display it. Pn is ignored. Refer to the Media Copy control function description for information about generating DECwriter descriptor.

ESC P Pn t - enter VT105 emulator mode

Accept the text that follows from the same data path as this sequence as VT105 commands to be executed by the VT125. The parameter is ignored and may be deleted (but if included, should be 0 for compatibility with future sequences). The VT105 emulator does not have the simultaneous text display capability of ReGIS.

String Terminator - ST  
ESC \

End the string of data and  
return the VT125 to text mode.

Media Copy - MC

ESC [ Ps i

Media Copy selects the connections between the different ports of the VT125. There are two classes of parameters (Ps) understood by this sequence: ANSI standardized and DEC private. Standardized and private parameters can not be in the same sequence. More than one parameter from a class can be in each sequence, using the semicolon syntax for multiple selective parameters (Ps;...;Ps). See the explanation of ports in the communication chapter for more information about selecting parameters.

ANSI parameters:

ESC [ 4 i

Turn off copying of data from the host computer to the auxiliary port.

ESC [ 5 i

Turn on copying of data from the host computer to the auxiliary port.

ESC [ 6 i

Turn off copying of data from the host computer to the text screen.

ESC [ 7 i

Turn on copying of data from the host computer to the text screen.

Private parameters:

ESC [ ? 0 i

Select the auxiliary port as the destination for DECwriter descriptor data containing the contents of the graphics memory as controlled by the S(H) option in ReGIS. Usually used to produce a hard copy of the screen on an LA34-VA. This is the default condition when using the ReGIS protocol.

ESC [ ? 2 i

Select the host computer as the destination for DECwriter descriptor data containing the contents of the graphics memory as controlled by the S(H) option in ReGIS. Usually used to store a file of DECwriter descriptor on the host computer, for later transmission to an LA34-VA or VT125.

## 9 REPORTS

Reports are transmitted by the VT125 in response to requests from the computer or other device. Reports are used to determine the cursor position, the type of terminal, and the operational status of the terminal. The following sequences are the requests for reports and the reports generated:

### Cursor Position Report

ESC [ P1 ; Pc R

This report is requested by a Device Status Report (DSR) sequence (ESC [ 6 n). The terminal reports the active position with the CPR sequence. This sequence has two parameter values, the first specifying the line and the second specifying the column. The default condition with no parameters present, or parameters of 0, indicates the cursor at home position. The numbering of lines depends on the setting of Origin Mode.

Device Attributes - DA

ESC [ Pn c

default value: 0

Request:

ESC [ c or ESC [ 0 c

A device asks the VT125 to identify itself by sending the DA control sequence with either no parameter or a parameter of 0.

Response:

ESC [ ? 12 ; <VT100 features> ;  
<VT125 features> ; <VT125 ROM  
version> c

The VT125 responds to the DA request with a DA sequence having numeric parameters only on the same data path that the request came from.

? 12

DEC private identifier for the VT125

<VT100 features>

5 if no advanced video option is installed. 7 if an advanced video option is installed. The VT125 checks the VT100 with an internal DA swap during power up or reset.

<VT125 features>

1 if a printer is connected to the auxiliary port. 0 if nothing is connected to the auxiliary port. The VT125 checks for a printer by reading the EIA DSR pin during power up or reset. Only printers that drive DTR can be detected.

<VT125 ROM version>

Number indicating the firmware revision level of the VT125 graphics processor code.

Identify Terminal (DEC Private) - DECID

Format: ESC Z

This sequence causes the same response as Device Attributes if the terminal is in ANSI mode. (See VT52 Reports.) This sequence will not be supported in future DEC terminals; therefore, any new software should use Device Attributes.

Device Status Report - DSR

Format: ESC [ Ps n default value: 0

Requests the general status of the VT125 with the following sequences:

ESC [ 5 n Command from computer - report status (using a DSR control sequence)

ESC [ 6 n Command from computer - report active position (using a Cursor Position Report control sequence)

Reports the general status of the VT125 on the same data path that the request came on with the following sequences:

ESC [ 0 n Response from VT125 - Ready, no malfunctions detected (default)

ESC [ 3 n Response from VT125 - Malfunction - soft error - reset and retry

DSR with a parameter value of 0 or 3 is always sent as a response to a requesting DSR with a parameter value of 5.

10            RESET

Reset To Initial State - RIS

ESC c Reset the VT125 to its initial state. This is the state it has after it powers up, performs the internal self-test, and reads the set-up information in

the user permanent SET-UP feature memory.

NOTE: When the terminal is reset, Cursor Key mode and Origin mode are reset, Keypad Numeric mode is selected, and the top and bottom margins of the scrolling region are set to be the complete screen. Any graphics protocol selection and the graphics memory are cleared and the graphics processor returns to text mode.

## 11 TESTS AND ADJUSTMENTS

The VT125 has many tests which are performed to be sure the terminal is running properly. Also, a pattern for screen alignment is provided. All DECTST sequences have an effect on the communication port. See Table 7-1. See the Operator Maintenance chapter for the meanings of displayed error codes.

Screen Alignment Display (DEC Private) - DECALN

ESC #8

E E E E E		This command fills the entire
E E E E E		screen area with uppercase E's
E E E E E	DECALN	for screen focus and alignment.
E E E E E	ESC #8	This command is used by DEC
E E E E E		manufacturing and Field Service
		personnel.

### Invoke Confidence Test - DECTST

Sequences with a first parameter of 2 tell the VT125 to tell the VT100 to do its self-tests according to the numeric parameter. Table 4-13 lists the VT100 tests. Sequences with a first parameter of 4 tell the VT125 to do its own self-tests according to the selective parameters that follow the 4. Table 4-14 lists the VT125 tests. See the Operator Maintenance chapter for explanations of the tests' actions.

NOTE: Be sure that these sequences get transmitted correctly because some wrong sequences do not give any indication of error.

## 12 INDICATORS

### Keyboard Indicators

The keyboard has seven indicator lights that are light emitting diodes (LEDs). The ON LINE and LOCAL indicators light to indicate the communication status of the terminal. If the keyboard is connected and power is on, either the ON LINE or the LOCAL indicator is on.

The KBD LOCKED indicator lights to show the keyboard locked condition. In this condition the keyboard transmit buffer is full and can not accept characters from the keyboard.



**Table 4-13 VT100 Self-tests**

**VT100 Self-test Format: ESC [ 2 ; Pn y**

<b>Sequence</b>	<b>Meaning</b>
ESC [ 2 ; 1 y	VT100 resets and performs power up test. Also causes VT125 power up self-test.
ESC [ 2 ; 2 y	VT100 Data Loop Back test. Must use test connector. Not usable while graphics processor is installed.
ESC [ 2 ; 3 y	VT100 power up and data loop back tests. Must use test connector. Not usable while graphics processor is installed.
ESC [ 2 ; 4 y	VT100 EIA modem control loopback test. Must use test connector. Not usable while graphics processor is installed.
ESC [ 2 ; 5 y	VT100 power up and EIA modem control loopback tests. Must use test connector. Not usable while graphics processor is installed.
ESC [ 2 ; 6 y	VT100 data loop back and EIA modem control loopback tests. Must use test connector. Not usable while graphics processor is installed.
ESC [ 2 ; 7 y	VT100 power up, data loop back and EIA modem control loopback tests. Must use test connector. Not usable while graphics processor is installed.
ESC [ 2 ; 9 y	Repeat VT100 power up test continuously until failure or power off. Not usable while graphics processor is installed.
ESC [ 2 ; 10 y	Repeat VT100 data loopback test continuously until failure or power off. Must use test connector. Not usable while graphics processor is installed.
ESC [ 2 ; 11 y	Repeat VT100 powerup and data loopback tests continuously until failure or power off. Must use test connector. Not usable while graphics processor is installed.
ESC [ 2 ; 12 y	Repeat VT100 EIA modem control loopback test continuously until failure or power off. Must use test connector. Not usable while graphics processor is installed.

Table 4-13 VT100 Self-Tests (Cont)

---

VT100 Self-Test Format: ESC [ 2 ; Pn y

---

Sequence	Meaning
ESC [ 2 ; 13 y	Repeat VT100 power up and EIA modem control loopback tests continuously until failure or power off. Must use test connector. Not usable while graphics processor is installed.
ESC [ 2 ; 14 y	Repeat VT100 data loop back and EIA modem control loopback tests continuously until failure or power off. Must use test connector. Not usable while graphics processor is installed.
ESC [ 2 ; 15 y	Repeat VT100 power up, data loop back and EIA modem control loopback tests continuously until failure or power off. Must use test connector. Not usable while graphics processor is installed.

---

Table 4-14 VT125 Self-Tests

---

VT125 Self-test Format: ESC [ 4 ; 1 ; Ps ... ; Ps y

---

Test parameters may appear in the sequence in any order but they always run in increasing numerical order. Always include the power up test parameter for correct display of error indications.

Ps = 1	VT125 Power up test
Ps = 2	VT125 Host port data loopback test
Ps = 3	VT125 Printer port data loopback test
Ps = 4	VT125 Color test
Ps = 5	VT100 Power up test (also causes VT125 Power up test)
Ps = 9	Repeat any selected tests continuously until power off or failure

See the Operator Maintenance chapter for the meanings of displayed error codes.

---

The L1 through L4 indicators are programmable and can be assigned any meaning for specific applications. The following sequences turn these indicators on or off:

Load LEDs (DEC Private) - DECLL

ESC [ Ps;Ps...Ps q default value: 0  
Load the four programmable indicators on the keyboard according to the parameter(s).

Sequence	Meaning
ESC [ 0 q	Clear indicators #1 through 4
ESC [ 1 q	Light indicator #1
ESC [ 2 q	Light indicator #2
ESC [ 3 q	Light indicator #3
ESC [ 4 q	Light indicator #4

Indicator numbers are indicated on the keyboard.

#### VT52 COMPATIBLE SEQUENCES

The VT125 VT52 compatible sequences meet private DIGITAL standards. Therefore, the VT125 can use existing software designed for previous terminals such as the VT52, only for text applications. The graphics processor cannot operate with VT52 compatible sequences. VT52 compatibility is selected from the keyboard in SET-UP (refer to chapter 2) or by the computer using a sequence (refer to the ANSI compatible sequences section of this chapter).

#### SET-UP FEATURE AND MODE SELECTION

While in VT52 mode, most of the SET-UP feature selections of the VT125 can not be selected using sequences. However, the following three modes can be selected using sequences:

- ANSI mode
- Alternate Keypad mode on
- Alternate Keypad mode off

#### 13 VT52 MODES

Enter ANSI Mode

Format: ESC <

All subsequent escape sequences are understood according to ANSI Standards X3.64-1979 and X3.41-1974. The VT52 escape sequences shown in this section are not recognized.

**Table 4-15 VT52 Mode Auxiliary Keypad Codes**

Key	Alternate Keypad Mode Off	Alternate Keypad Mode On
Ø	Ø	ESC ? p
1	1	ESC ? q
2	2	ESC ? r
3	3	ESC ? s
4	4	ESC ? t
5	5	ESC ? u
6	6	ESC ? v
7	7	ESC ? w
8	8	ESC ? x
9	9	ESC ? y
-(minus)	-(minus)	ESC ? m
,(comma)	,(comma)	ESC ? l
.(period)	.(period)	ESC ? n
ENTER	Same as RETURN key	ESC ? M
PF1	ESC P	ESC P
PF2	ESC Q	ESC Q
PF3	ESC R	ESC R
PF4	ESC S	ESC S

**Alternate Keypad Mode On**

Format: ESC =

The auxiliary keypad keys will send unique identifiable escape sequences for use by applications programs. Table 4-15 lists these codes and sequences.

**Alternate Keypad Mode Off**

Format: ESC >

The auxiliary keypad keys send the ASCII codes for the functions or characters on the keys.

**14 VT52 CHARACTER SETS AND SELECTION**

While in VT52 mode the VT125 can use either the character set selected in SET-UP B or the VT125 Special Character and Line Drawing character set. The following sequences select the character sets.

Enter Graphics Mode

Format: ESC F Causes the special graphics character set to be used.

NOTE: The special graphics characters in the VT125 are different from those in the VT52. See Table x-x in Appendix X.

Exit Graphics Mode

Format: ESC G This sequence causes the standard ASCII character set to be used.

## 15 VT52 CURSOR POSITIONING

The cursor indicates the location of the active position. This is where the next graphic character appears. The cursor always moves one column to the right when a graphic character is displayed, and moves down one line when a line feed is received. The cursor moves to the left margin when a carriage return is received. If a command tries to move the cursor past any margin, the action that will result is stated. The VT52 mode margins are always the top and bottom of the display screen. Table 4-16 lists the sequences that move the cursor according to their parameters:

Table 4-16 Special Character and Line Drawing Set and Graphics Mode Comparison

Octal Code	US/UK Set	Special Character and Line Drawing Set	VT52 In Graphics Mode*
137		Blank	Blank
140	\	<>	Reserved
141	a	Checkerboard (error indicator)	Solid rectangle
142	b	ht	1/ 3/
143	c	ff	5/ 7/
144	d	cr	7/
145	e	lf	0/
146	f	°	Degrees
147	g	+ -	Plus or minus
150	h	nl	Right arrow
151	i	vt	Elipsis (dots)
152	j		Divide by
153	k	~	Down arrow
154	l		Bar at scan 0
155	m	L	Bar at scan 1
156	n	+	Bar at scan 2
157	o	-	Bar at scan 3
160	p	-	Bar at scan 4
161	q	-	Bar at scan 5
162	r	-	Bar at scan 6
163	s	-	Bar at scan 7
164	t	-	Subscript 0
165	u	-	Subscript 1
166	v	_	Subscript 2
167	w	⌠	Subscript 3
170	x		Subscript 4
171	y	<=	Subscript 5
172	z	=>	Subscript 6
173	{	i-i	Subscript 7
174		/=	Subscript 8
175	}	L-	Subscript 9
176	~	.	Paragraph

\* Not available in VT125.

16                   VT52 ERASING

Erasing removes characters from the screen of the VT125. When characters are erased from the screen, the characters are lost. The following sequences erase characters from the screen:

Erase to End of Screen

Format: ESC J

Erase all characters from the cursor to the end of the screen. The cursor does not move.

Erase to End of Line

Format: ESC K

Erase all characters from the cursor to the end of the current line. The cursor does not move.

17                   VT52 REPORTS

The VT125 generates only one report in VT52 mode:

Identify

Format: ESC Z

This sequence causes the terminal to send its identifier escape sequence to the computer.

The response is ESC / Z.

NOTE: This is the VT52 response.

Table 4-17 VT52 Cursor Positioning

---

Cursor Up

Format: ESC A                      Move the cursor up one line in same column. Cursor stops at the top of the screen.

Cursor Down

Format: ESC B                      Move the cursor down one line in same column. Cursor stops at the bottom of the screen.

Cursor Right

Format: ESC C                      Move the cursor one column to the right. Cursor stops at the right margin.

Cursor Left

Format: ESC D                      Move the cursor one column to the left. Cursor stops at the left margin.

Cursor to Home

Format: ESC H                      Move the cursor to the home position at line 1, column 1.

Reverse Line Feed

Format: ESC I                      Move the cursor up one line in the same column. If the cursor is at the top margin, a scroll down is performed.

Direct Cursor Address

Format: ESC Y line column        Move the cursor to the specified line and column. The line and column numbers are sent as the ASCII characters whose codes are the decimal numbers plus 31; for example, 32(10) (SPACE) refers to the first line or column, and 111(10) refers to the eightieth column.

---



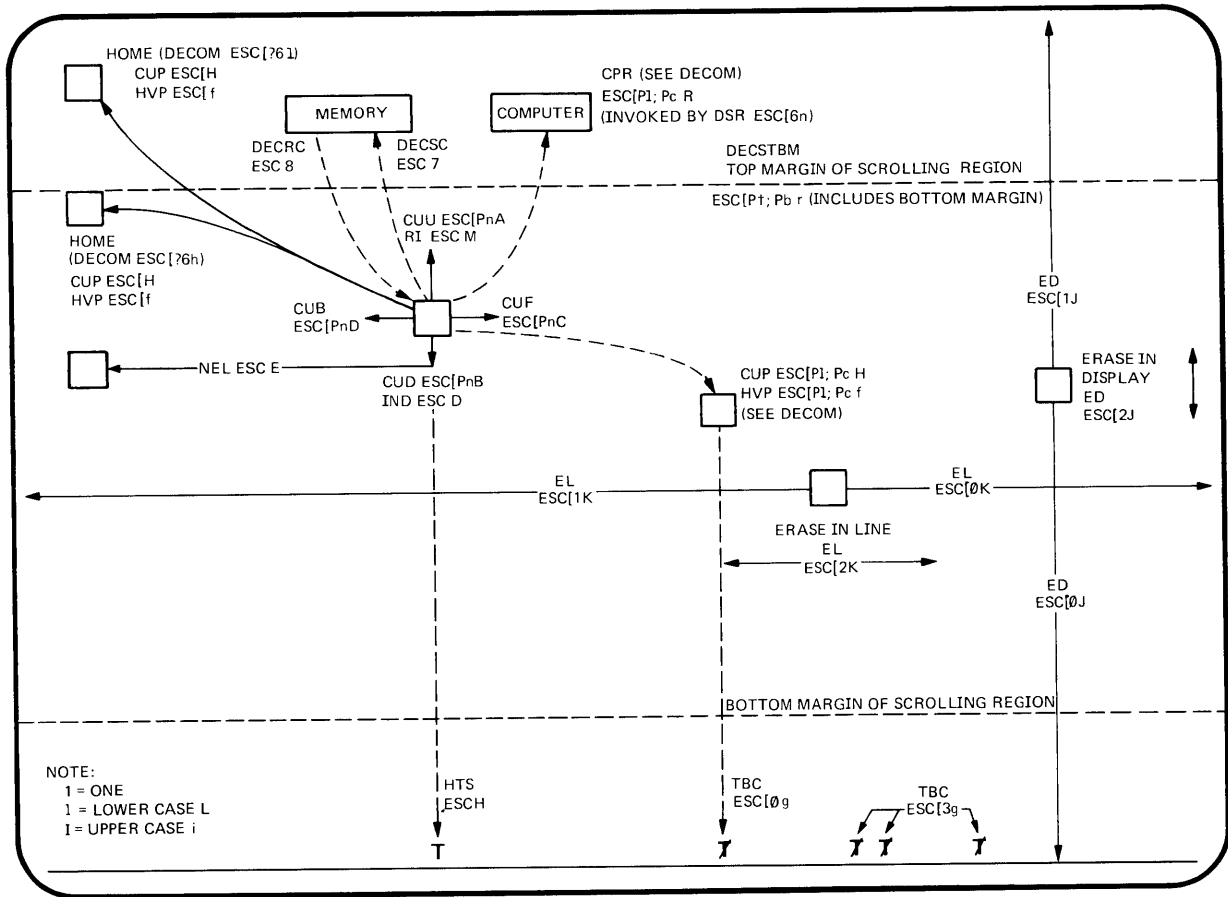

NOTE:  
 1 = ONE  
 l = LOWER CASE L  
 I = UPPER CASE I

DECDDL	<b>AB</b>	TOP HALF ESC #3 BOTTOM HALF ESC #4	<b>A</b>	SGR OFF ESC [0m	DESIGNATION: G0 INVOKED BY: SI: CTRL/O U.K. ESC(A) U.S. ESC(B) GRAPHICS ESC(0) ALT ROM ESC(1) ALT SPECIAL ESC(2)	G1 SO: CTRL/N ESC(A) ESC(B) ESC(0) ESC(1) ESC(2)	<ul style="list-style-type: none"> <li>• DECCKM-Cursor Keys application cursor control</li> <li>• DECCOLM 132 column 80 column</li> <li>• DECPAM keypad application</li> <li>• DECPNM keypad numeric</li> <li>• DECOM-Origin Mode relative absolute</li> <li>• DECSCLM smooth scroll jump scroll</li> </ul>	ESC[?1h ESC[?1l ESC[?3h ESC[?3l ESC = ESC > ESC[?6h ESC[?6l ESC[?4h ESC[?4l
DECDDL	<b>AB</b>	ESC #6	<b>A</b>	BOLD ESC [1M UNDERSCORE ESC[4 m BLINK ESC[5M	<ul style="list-style-type: none"> <li>• DECANM ANSI mode (from VT52) VT52 mode (from ANSI)</li> <li>• DECARM autorepeat no autorepeat</li> <li>• DECAWM autowrap no autowrap</li> </ul>	ESC < ESC[?2l ESC[?8h ESC[?8l ESC[?7h ESC[?7l		
DECSDL	<b>AB</b>	ESC #5	<b>A</b>	REVERSE ESC[7 m (BLACK-ON-WHITE)				
E E E E E				DECSCNM-SCREEN				
E E E E E		DECALN	<b>A</b>	REVERSE ESC [?5h (BLACK-ON-WHITE)				
E E E E E		ESC #8	<b>A</b>	NORMAL ESC [?5l (WHITE-ON-BLACK)				
E E E E E								

MA-9481

Figure 4-1 VT125 ANSI Mode Display Control Functions



## INTRODUCTION

This chapter explains the Remote Graphic Instruction Set (ReGIS), a graphic descriptor, as it is used in the VT125 graphics processor. With the information in this chapter, a programmer can prepare images for display on the VT125 internal monitor or a connected color monitor, or print the images on a DECwriter graphic printer.

## Definitions

ReGIS is called a graphic descriptor. A graphic descriptor is a symbol system that describes the parts of an image. An image is a type of information that people understand by seeing it and thinking about it in relation to familiar visual images. An image (graphic) is the best way to communicate some types of information. The problem for a graphic descriptor is to describe the image with as few symbols as possible to save storage space and communication line time. ReGIS works by considering an image to be a group of graphic objects. Each graphic object is a standard geometric form that can be described with a few characters of information. For example, ReGIS understands that the form of a circle applies to any circle that can be drawn. A circle can be described on the screen by the location of its center and a point on its circumference. The same type of understanding for other graphic objects lets ReGIS describe graphic images with short commands.

Each graphic object is made of a group of the smallest units of information on the screen. These units are pixels; their size is determined by both the minimum size of unit that the monitor can display, and by the maximum number of units that the graphics processor can address and store. If a device can display more pixels than another, it has higher resolution than the other. The VT125 graphics processor can display 184,320 pixels in a 768 X 240 array and is considered a medium resolution device. The graphics processor's memory can store 196,608 pixels in a 768 X 256 X 2 array. The display of the VT125 is a window that looks into this memory. The window can move in any direction with a Screen command to display all parts of the pixel memory, or to move an object in the image to the center of the display.

**Table 5-1 VT125 Graphics Protocols**

<b>Protocol</b>	<b>Example String</b>
ReGIS	ESC P p ...data... ESC \
LA34-VA Hard Copy Descriptor	ESC P q ...data... ESC \
VT105 Emulation	ESC P t ...data... ESC \

**ReGIS SYNTAX**

**Introduction**

The VT125 graphics processor command syntax is a Device Control String (DCS) introducer sequence (ESC P), followed by protocol selection characters, followed by any number of characters in the selected protocol, followed by the String Terminator (ST) sequence (ESC \). (These sequences are explained in detail in the Received Character Processing chapter of this book under VT125 Communication and Graphic Protocol Controls.) The first characters after ESC P select the graphic protocol that is used during the rest of the string. These characters are formatted as part of a private ANSI control sequence. Table 5-1 lists the possible graphic protocols with typical device control strings. See the Received Character Processing chapter for complete details.

The LA34-VA Hard Copy Descriptor protocol is explained in the Protocol Controls section that was mentioned above. The VT105 Emulation Protocol is explained in the VT105 chapter of this book. The ReGIS protocol is explained here.

**ReGIS Single Character Commands**

Any commands from the complete ReGIS instruction set can follow the initial selection characters. A ReGIS command is a single alphabetic command key character followed by options in many formats including parentheses and brackets. ReGIS does not care whether an alphabetic character is uppercase or lowercase except in any quoted string. The key character is usually the first letter of the name of the command, for example "S" for screen. Any keyletter that is not included in this guide, and any characters in parentheses, quotes, or brackets, or any digit strings, that follow the invalid keyletter or a semicolon are ignored.

**Parentheses, Brackets, Pixel Vectors, and Quotes**

Parentheses "(" and ")" after a single character mean that the characters inside the parentheses are options to the command (example: S(E) = screen erase). This book shows a general option with the symbol command(option<arg>) where command is the command keyletter, option is typically an option keyletter, and <arg> is the number, letter-number, bracketed, or quoted argument of the option. The angle bracket characters "<" and ">" are shown to highlight the argument; they are never actually part of a command. Options have the same format as a complete ReGIS command.

Numbers in brackets "[" and "]" are position information (also called coordinate or point specifiers). This book shows a general position with the symbol [ $\langle\text{position}\rangle$ ], where  $\langle\text{position}\rangle = "x"$  or  $,"y"$  or  $"x,y"$ . The first number is the x-axis or horizontal position, and the second number is the y-axis or vertical position. A comma separates the two numbers. When only one number is in brackets without a comma (or with a comma after it), it is a new x position while the y position stays the same. When only one number is in brackets with a comma in front of it, it is a new y position while the x position stays the same. When the numbers do not have + or - signs with them, the position given is absolute (referred to the origin). When the numbers do have + or - signs with them, the position is relative (referred to the current position). At power up, the position coordinates have [0,0] at the top left corner of the screen and [767,479] at the bottom right corner of the screen. (See Screen Addressing Definition, S(A), to change the coordinate system.)

#### Examples:

[200,100] is absolute,  $x = 200$ ,  $y = 100$ .  
[+200,-100] is relative,  $x = \text{current} + 200$ ,  $y = \text{current} - 100$ .  
[200] is absolute,  $x = 200$ ,  $y = \text{unchanged}$  (same as [200,+0]).  
[+200] is relative,  $x = \text{current} + 200$ ,  $y = \text{unchanged}$ .  
[,100] is absolute,  $x = \text{unchanged}$ ,  $y = 100$  (same as [+0,100]).  
[-100] is relative,  $x = \text{unchanged}$ ,  $y = \text{current} - 100$ .

If a key letter has one or more numbers after it with no parentheses, brackets, or quotes, the numbers are pixel vectors. These are position information that specifies movement in one of eight possible directions. This book shows general pixel vectors by the symbol  $\langle\text{pv}\rangle$  or  $\langle\text{pixel vector}\rangle$  after a key letter. See the Position command for more information.

Quotes indicate characters that the Text command can put on the screen as they appear. Both ' and " are quote characters. This book shows a general text string with the symbols 'text' or "text". The Text command explains quotes in detail.

#### Commas and Spaces

Parenthesized commands can appear next to each other (except for E) or they can be separated with commas, spaces, or other control characters. Separated commands are easier to read and are good ReGIS practice except when the communication line speed limits performance. (See Screen Erase for E's special restriction.)

#### Control Characters

ReGIS ignores control characters (columns 0 and 1 of Table 4-1 plus space and delete). The VT125 (which supervises the communications between ReGIS and the communication lines), monitors the data for ESC. If ESC appears, the VT125 checks for the String Terminator sequence. If the sequence is the String Terminator (ESC \), the VT125 returns to text mode. If the sequence is a control function that applies to the graphics processor (DA, DECID, DECTST, DSR, MC, RIS, see Chapter 4), its action is performed. Any other characters after ESC pass to ReGIS as ReGIS commands, not as ANSI control functions.

Because ReGIS ignores control characters, ReGIS command strings can be formatted to make them easy to read. In particular, spaces, carriage returns, and line feeds can be in the listing of ReGIS commands as instructions to the terminal or printer for page formatting for display. Most of the commands in this book are shown with spaces between key letters and option values for clarity. The commands can be copied exactly because ReGIS ignores the spaces, but to save storage and communication time, all spaces can be removed except those inside quoted strings.

#### Order of Performance

As each command arrives, it is acted on. ReGIS always responds to each command and option as soon as it has enough information to work with. The parentheses, brackets, and quotes described above control the way ReGIS responds to the characters of the string. For example, a left bracket "[" tells ReGIS to look for a position specification. A right bracket "]" ends the position specification. If a communication line error or a programming error loses the right bracket, all the following ReGIS commands will probably be understood incorrectly. The semicolon character, if included in the string of commands, clears any control errors caused by unmatched sets of parentheses or brackets. This is called synchronization. Enough semicolons mixed with commands can help get the most usable image on the screen even in the presence of communication problems. (A semicolon cannot clear errors involving quotes because inside quotes, it is a literal character instead of an instruction.)

An option selection applies to all the following related commands unless it is a temporary write option or a curve option. For example, giving the W(C) command causes all writing to be in complement mode until another writing mode command is given. However, a writing control can be a temporary option if it is an option to any V, C, or T command. For example, a pixel vector multiplier in a screen command applies only to that command, for example S(W(M100))<pv>. Options can be specified by their option key letter in parentheses without the command key letter if the given command is still in effect. For example, a line can be drawn with the Vector command starting with one intensity and ending with another: V (W(I3)) [+100] (W(I2)) [+100].

#### Numeric Values

The VT125 does all its calculations with integers. This means that the smallest meaningful value that it can understand is the distance between two pixels. That distance is 1. The terminal's coordinate system is designed to address the pixels with integers. The VT125 accepts decimal fractions (1.53) and floating point numbers (3.21E2) so that images can be transported to higher resolution ReGIS devices. However, those numbers are truncated (cut off) during processing so that only the integer portions are used in calculations, with no rounding (1.53 = 1, 3.21E2 = 321). Floating point numbers are truncated to 16 bit signed integers (after scaling, if allowed by the coordinate system); values larger than  $(2^{**15})-1$  are kept as  $(2^{**15})-1$ , and values smaller than  $-(2^{**15})$  are kept as  $-(2^{**15})$ .

## POSITION

The most basic concept in the use of ReGIS is the idea of the current position. This is a location on the screen with many possible functions. It is generally the last position where a drawing or command action occurred. It may be the location of the next pixel to be drawn, it may be the center of a circle, it may be the starting point of a vector, or many other things. If ReGIS is active in the VT125 but not processing data, a blinking graphic cursor appears to mark the current position. The graphic cursor is a diamond shape with a cross in it.

## Coordinates

A coordinate is a number that specifies a position. X-coordinates specify horizontal positions and Y-coordinates specify vertical positions. A point is the intersection of an imaginary vertical line that passes through an X-coordinate and an imaginary horizontal line that passes through a Y-coordinate, and so a pair of coordinates specifies a point. (The coordinates are sometimes called point specifiers in ReGIS documentation.) The general symbol for a pair of position coordinates in this book is [`<position>`].

When the VT125 is first powered up, it starts counting screen positions at the top left corner of the screen. This position is called the screen origin and has coordinates [0,0]. The X-coordinates start at 0 at the left margin of the screen and end at 767 at the right margin of the screen. The Y-coordinates start at 0 at the top margin of the screen and end at 479 at the bottom margin of the screen. With these coordinates, the VT125 can address all pixels on the screen with integer numbers. On the 12 inch monitor screen in the VT125, horizontal pixels are about one hundredth of an inch apart. The scan lines, which define the vertical pixel spacing, are about two hundredths of an inch apart. To let the same number of horizontal and vertical addresses be equal distances on the screen, the addressing counts by one for horizontal pixels and by two for vertical pixels. (See explanation of pixels in Writing Commands.)

## POSITION COMMAND

The P (position) command sets or changes the current position and moves the graphics cursor to the new current position.

## Absolute Position

Format: P[`<x_coordinate,y_coordinate>`]

This command moves the current position to the given coordinates referred to the origin. If a coordinate is not signed, it is an absolute coordinate. If an x- or y- coordinate is not given, its value is unchanged.

## Relative Position

Format: P[<+-x\_change,+y\_change>]

This command moves the current position by adding the given numbers to the last current position. If a coordinate is signed, it is a relative coordinate. If an x- or y- coordinate is not given, its value is unchanged. (For negative values of change, adding is the same as subtracting a positive value.)

## Combining absolute and relative positions

Absolute and relative values can be combined in one command. Sign the coordinate that is relative and leave the absolute coordinate unsigned.

## Null Position

Format: P[]

This command resets the writing pattern so that the next writing operation begins with the first bit in the pattern memory. See Patterns in Writing Controls. The "[]" argument is a relative position specification indicating no change in x or y.

## Pixel Vectors

Format: P<pixel vector>

This command moves the current position in the direction specified by <pixel vector> (also shown as <pv>). A pixel vector is a vector whose length is the distance between two pixels times a multiplier that is set with a Writing Control command. A pixel vector has a limited set of directions that it can specify. These are eight directions at 45 degree intervals starting at 0 on a 360 circle. They are specified by the integers 0 through 7 according to Figure 5-1.

Each time a pixel vector number appears after the key letter P, the current position moves one pixel multiplier in that direction. Thus, P000 moves the current position three pixels to the right. See Pixel Multiplier below.

## Temporary Pixel Vector Multiplier

Format: P(W(M<multiplier>))<pv>

Sets a temporary pixel vector multiplier for the following series of pixel vectors in this command



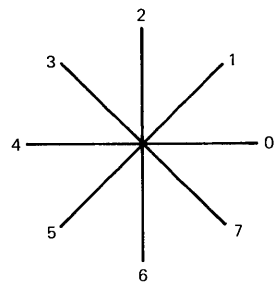

MA-9464

**Figure 5-1 Pixel Vector**

only. The multiplier can be any positive integer. Each pixel vector number that follows the multiplier moves the current position by the multiplier number of pixels. When the VT125 powers up, the multiplier is 1, meaning that each command moves the current position only one pixel, a very small amount. The multiplier increases the power of the pixel vector command.

#### Begin a Bounded Sequence of Coordinates

Format: P(B)

Saves the first position to allow return to the beginning position without respecifying that position. The saved position is restored by the (E) command. The (B) command can be repeated up to 10 times and each value of position is saved. Each (E) command then restores the most recently saved position, until the tenth (E) command restores the first value saved. The positions stored and recalled include those stored in the Vector V(B) command.

#### Start an Unbounded Sequence of Coordinates

Format: P(S)

This command is similar to the (B) command explained above except that it specifically does not move the cursor at the end of a sequence of positions. (S) saves a dummy or non-acting position in memory so that the next (E) command does not change the current position. Positions saved by (S) are in the same memory as (B) positions and are included in the ten count. The Position (S) command is provided for symmetry with the other commands that have (B) and (S) options.

#### End a Sequence of Coordinates

Format: P(E)

Restores the first position at the end of a P(B) command.

B, S, and E options are used to group sets of coordinates together in blocks (position blocks) so they can be processed as units, for example, for polygon definition or filling or shading operations. The position blocks do not have to be completed in a single P command, and they can have V or C commands inside them. (See B, S, and E in Vectors and Curves)

**Table 5-2 Position Command Summary**

---

P { [ ]	} Reset pattern memory
{ [ <position> ]	} Move to <position>
{ <pixel vector> or <pv>	} Move <multiplier> pixels
{	} in <pv> direction
{ (B)	} Save current location
{ (S)	} Save dummy location
{ (E)	} Move to last saved location
{ (W(<temporary writing controls>))	} P(W(M<multiplier>))

---

Table 5-2 is a summary of the Position Commands.

#### WRITING COMMANDS

##### General

The Writing Commands section explains the ways of specifying the locations of pixels for lines, shapes, and text. The next section, Writing Controls, explains the attributes of intensity and pattern that pixels and shapes can have. The Screen Controls section explains the controls for the color and background of images, the positioning of the complete image, timing of actions, and the production of hard copy output.

##### Pixels

A pixel is the smallest unit of color and intensity information on the screen. The intersection of every horizontal address and every even vertical address is a pixel. (See Coordinates in Position.) The writing commands do two processes at each address. They access the address (prepare to write into it) and then act on it. The action can be setting bits (see Foreground Planes in Screen Controls), clearing them, complementing them, or perhaps doing nothing at all. (See Patterns in Writing Controls.)

##### Odd-Y Simulation

There are 512 defined vertical addresses but only 256 actual memory locations. Only every even-numbered vertical address has any associated memory. The next higher odd vertical address accesses the same pixel memory as the even address. This is called odd-y simulation and allows dimensions to be consistent in both axes (squares have the same number of addresses on each side). Some combinations of pattern and multiplier may give unexpected results because of odd-y simulation. See Pattern Multiplier in Writing Controls for more information.

## VECTOR COMMAND

The Vector command draws a straight line between the current cursor location and a specified screen location.

### Dot at Current Position

Format: V[]

This command draws a dot (one pixel) at the current position. It is useful because most other vector commands do not draw the pixel at the current position.

### Vector from Current Position to Specified Position

Format: V[<position>] [<position>] ...

This command draws a straight line from the first pixel after the current position to the position given. Any number of positions can be included in the same Vector command to draw a continuous series of straight lines. The first dot of each line is not drawn so that the next line can connect smoothly to the previous line. Use the dot command V[] to draw the first dot of a series of vectors.

NOTE: With shading on, the vector command draws from the current position.

Round-off errors in the VT125's computation of vectors can add. The main causes of cumulative errors are relative coordinates or non-default display addressing (see Screen Controls), especially with non-integer specifiers. If you need an absolute position after a series of vectors, you should include a Position command. This starts the next commands at a known location.

See Patterns in Writing Controls for details about how the Vector command uses patterns.

### Pixel Vectors

Format: V<pixel vector>

This command draws a line one pixel multiplier long in the direction specified by <pixel vector> (also shown as <pv>). The direction may be any of the integers 0 through 7 according to Figure 5-2. The direction numbers represent angles at 45 degree intervals from 0 (0) to 315 (7).

Each time a pixel vector number appears after the key letter, the line is drawn one more one pixel multiplier in that direction. Any number of the eight pixel vectors numbers can appear in the

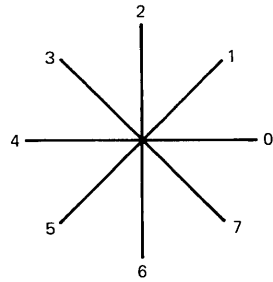

MA 9464

Figure 5-2 Pixel Vector

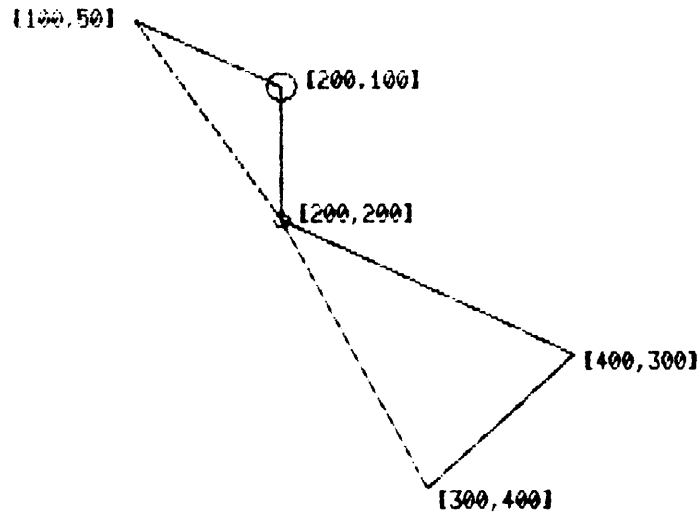

```
p[200, 100] v(b)[200, 200](b) v[300, 400]
v[400, 300] v(e)c[+5] v[100, 50] v(e)c[+10]
```

MA-9444

Figure 5-3 Nested (B) and (E) Commands

command. Thus, V00066 draws a line three pixel multipliers to the right and then two pixel multipliers down. (The pixel multiplier is the actual number of pixels changed in any command that affects pixels. The power-up default is 1 but it can be set to any convenient value. See Pixel Multiplier in the Writing Controls section.)

### Bounded Sequence of Positions

Format: V(B) [<position>]... [<position>] (E)

The (B) command saves the current position in the graphics processor's memory so that you do not need to specify the end position of a sequence of vectors that you want to end at the starting position. At the end of the sequence, the (E) command recalls the position. The Vector command then draws a line from the last specified position to the saved position. The (B) command can save up to 10 positions in memory. Each (E) command recalls the position saved by the last (B) command and erases the position from memory. The positions stored and recalled include those stored with the Position P(B) command. Figure 5-3 illustrates the action of the "nested" (B) and (E) commands. (E) 2 recalls (B) 2; the next (E) is 1 which recalls (B) 1.

```
V (B) 1[<position1>] (B) 2[<position2>] -->
      (E) 2[<position2>] (E) 1[<position1>]
```

### Unbounded Sequence of Positions

Format: V(S) [<position>]... [<position>] (E)

This command is similar to the (B) command explained above except that it specifically does not move the cursor or draw a vector at the end of a sequence of positions. (S) saves a dummy or non-acting position in memory so that the next (E) command does not change the current position. Positions saved by (S) are in the same memory as (B) positions and are included in the ten count.

The Vector (S) command is provided for symmetry with the Open Curve (S) command. (Note that the Open Curve command requires null position specifiers to draw the same segments as the Vector (S) command. These specifiers in a sequence of positions do not affect the Vector command except for drawing the first dot of a line.)

**Table 5-3 Vector Command Summary**

---

V { []	}	Draw dot at current position
{	}	
{ [<position>]	}	Draw vector to <position>
{	}	
{ <pixel vector> or <pv>	}	Draw <multiplier> pixels
{	}	in <pv> direction
{	}	
{ (B)	}	Save current position
{	}	
{ (S)	}	Save dummy position
{	}	
{ (E)	}	Draw to last saved position
{	}	
{ (W(<temporary writing controls>))	}	V(W(M<multiplier>))

---

### Temporary Writing Controls

Format: V(W(<temporary writing control options>))

The temporary writing control options are the same as the Writing Controls command options but they apply only during the Vector command that they are in. Only options specified or implied by those specified are changed. Options return to their previous values at the end of the V command.

Table 5-3 is a summary of the Vector Commands.

### CURVES

The Curve command draws these members of the family of graphic objects called curves.

- Circles
- Arcs
- Closed Curves
- Open Curves

A circle is a group of pixels that are all the same distance away from a center position. There are two types of curve commands that generate circles; they use different information to specify the circle.

An arc is a part of a circle. There are two types of curve commands that generate arcs; they use the same information as the two circle commands to specify the circle that the arc is part of. They also use information to determine what part of the circle is drawn.

A closed curve is a general curve that is made by interpolating the locations of pixels around four or more specified locations.

The closed curve is a bounded shape like the circle (which is a special case of the closed curve) or an ellipse.

An open curve is a general curve that is made by interpolating the locations of pixels around several specified locations. The endpoints of the open curve are not meant to meet. You must pay special attention to the endpoints of an open curve to get the graphic object that you want.

## Circles

### Circle with Center at Current Position

Format: C[<position>]

This command draws a circle around the current position with the circumference at the specified position. See Figure 5-4. The radius of the circle is the distance from the current position at the center to the circumference.

The current position stays at the center after the circle is drawn.

### Circle with Center at Specified Position

Format: C(C)[<position>]

This command draws a circle around the specified position with the current position located on the circumference. See Figure 5-5. The radius of the circle is the distance from the current position to the center.

The current position stays at the starting location on the circumference after the circle is drawn.

## Arcs

An arc is a part of a circle. It is specified by the location of the center of the circle, the radius of the circle, the starting position of the arc, and the amount of the circle to be drawn, measured in degrees. A complete circle is 360 degrees.

### Arc with Center at Current Position

Format: C(A<degrees>) [<position>]

This command draws an arc that is <degrees> around a circle starting from <position>. The radius of the circle that the arc is a part of is the length between the current position and <position>. The graphics processor draws the arc counterclockwise for the specified number of positive degrees and clockwise for negative degrees. The current position stays at the center after the arc is drawn. See Figure 5-6.



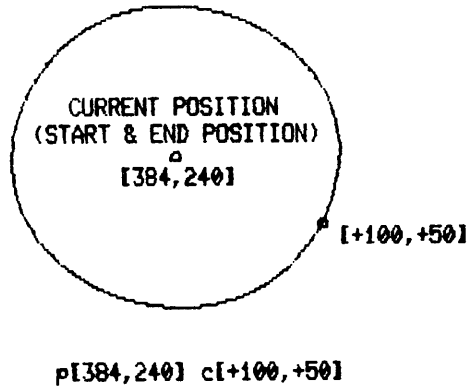

MA-9441

Figure 5-4 Circle with Center at Current Position

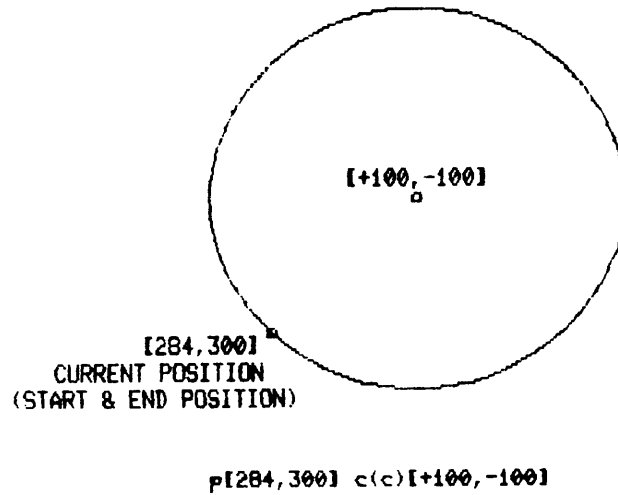

MA-9439

Figure 5-5 Circle with Center at Specified Position

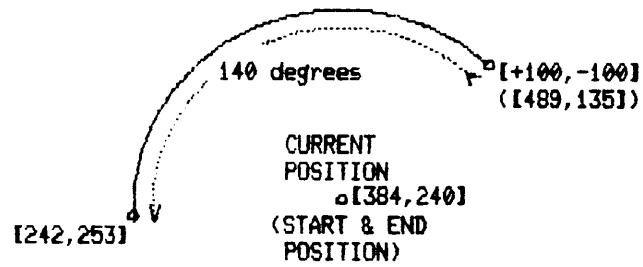

p[384,240] c(a140)[+100,-100]

MA-9440

Figure 5-6 Arc with Center at  
Current Position

## Arc with Center at Specified Position

Format: C(A<degrees> C) [<position>]

The command draws an arc that is <degrees> around a circle starting at the current position. The center of the circle that the arc is a part of is at <position>. The radius is the distance between the current position and <position>. The graphics processor draws the arc counterclockwise for the specified number of positive degrees and clockwise for negative degrees. The current location is at the end of the arc after the arc is drawn. See Figure 5-7.

## OPEN AND CLOSED CURVES

### Interpolation of curves

Given a sequence of positions, ReGIS can draw a curve between the positions. The curve represents a generalized nonlinear function that intersects all the specified positions. It is generalized because it is not the result of the actual function that specified the points. It is the result of a graphic technique that produces a reasonable imitation of a function curve. The curve indicates the presence of a nonlinear function, rather than the function itself. You cannot get accurate intermediate values from a graphics processor curve unless you have given enough positions to ensure that the curve generator is closely following your function. The curve generator can produce a curve segment with as few as four positions. The result can be misleading if the positions are too far apart to define the function by themselves.

### Unbounded (Open) curves

Format: P[<position>]C(S) [[] [<position>]... [<position>] [[] (E)

An open curve is a general curve that is made by interpolating the locations of pixels around several specified locations. The endpoints of the open curve are not meant to meet. See Figure 5-8. You must pay special attention to the endpoints of an open curve to get the graphic object that you want. The open curve command can draw a curve segment with as few as four positions including the position preceding the (S) command. To ensure that segments are drawn between all given positions, include null position specifiers ([]) at the beginning and end of the list of positions. Otherwise, only the segments from the second to the next to last positions are drawn.

The current position stays at the next to last position specifier after the curve is drawn. When null specifiers are used, the last position and the next - to - last position are the same.

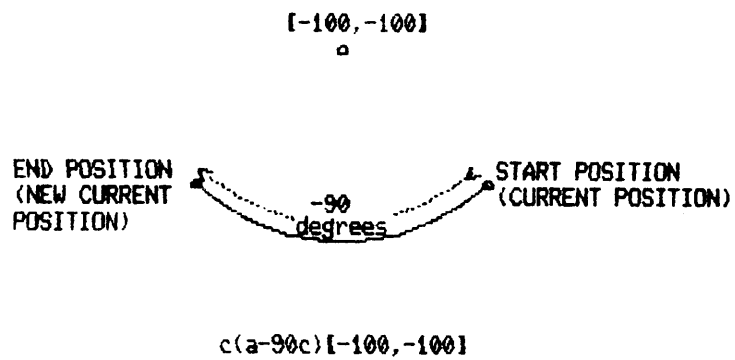

MA-9447

Figure 5-7 Arc with Center at Specified Position

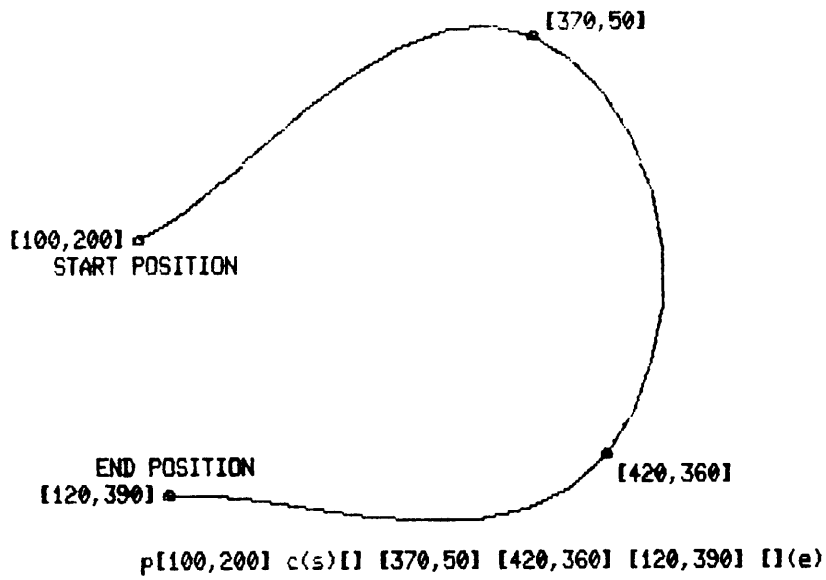

MA-9448

Figure 5-8 Unbounded (Open) Curves

## Bounded (Closed) curves

Format: P[<position>]C(B)[<position>]...[<position>](E)

A closed curve is a general curve that is made by interpolating the locations of pixels around four or more specified locations. The closed curve is a bounded shape like the circle (which is a special case of the closed curve) or an ellipse. See Figure 5-9. The (B) command saves the beginning position and the (E) command closes the curve by providing the beginning position as the last position specifier for the curve command.

The current position returns to the second position specifier after the curve is drawn.

## Temporary Curve Writing Controls

Format: C(W(temporary writing controls))

The temporary writing control options are the same as the Writing Controls command options but they apply only during the Curve command that they are in. Only options specified or implied by those specified are changed. Options return to their previous values at the end of the C command.

Table 5-4 is a summary of the Curve Commands.

**Table 5-4 Curve Command Summary**

---

C {	[<position>]	}	Circle with Center at Current
{		}	Position, Circumference at
{		}	<position>
{	(C) [<position>]	}	Circle with Center at
{		}	<position>, Circumference
{		}	at Current Position
{	(A<degrees>) [<position>]	}	Arc with Center at Current
{		}	Position, starting at
{		}	<position> for <degrees>
{	(A<degrees>C) [<position>]	}	Arc with Center at <position>,
{		}	starting at current position
{		}	for <degrees>
{	(B) [position]...[position] (E)	}	Bounded (closed) curve
{	(S) [] [position]...[position] [] (E)	}	Unbounded (open) curve
{		}	
{	(W(temporary writing controls))	}	

---

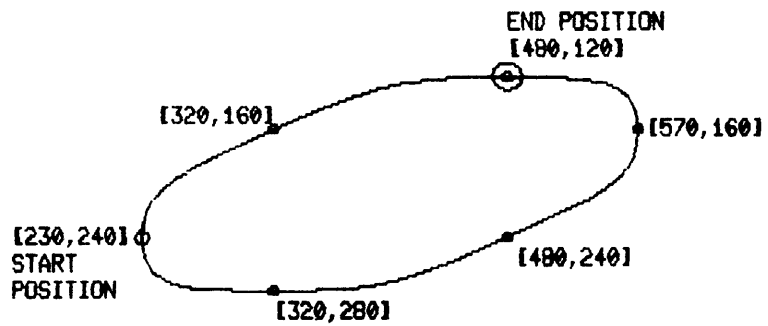

p[230,240] c(b)[320,160] [480,120]  
 [570,160] [480,240] [320,280] (e)

MA-9446

Figure 5-9 Bounded (Closed) Curves

## TEXT

### General

The graphics processor displays characters differently from the text terminal. The ReGIS Text command can draw characters with many combinations of size, orientation, and position. This section explains the Text commands.

The Text command is formatted as a keyletter followed by options and a quoted string. All options in the T command, except temporary write options, apply to all following T commands until they are changed in another T command. ReGIS understands that two quotes of the same kind next to each other, inside a string that is delimited by the same kind of quote, means that one quote is supposed to be displayed inside the string. But with both kinds of quotes available, you can include one kind or the other inside the string without having to double it up. Two strings delimited by the same kind of quotes can be concatenated by separating them with a comma. For example, "stop\*", "here" is the same as "stop\*here". Empty strings are allowed (""), because doubling only occurs inside a string. There is no defined upper limit on the length of a string.

ReGIS never uses the characters inside a pair of quotes or double quotes as commands. These include the semicolon synchronization character and the macrograph definition and invocation characters. Printing characters (space through ~, octal 40 through 127, see Character Sets in Chapter 4) are displayed according to the pattern stored in the currently-selected alphabet. (This defaults to ASCII.) All control characters except CR, LF, HT, and BS are ignored.

CR (carriage return) moves the active position to the position it had when the current quoted string began to be drawn. LF (line feed) moves the active position down a distance equal to the current vertical cell size. HT (horizontal tab) acts as a non-printing space. HT moves the active position forward one character position without affecting any image in that character position. BS (backspace) moves the active position back one current text spacing distance to the last written character position. This is the simplest method of performing an overstrike (drawing two characters in the same place, such as zero with a slash).

The initial position in a text command is the current position at the end of any other writing command. This position is the top left corner of the next character to be drawn. The size and spacing values of the text command then control where the next current position occurs.



## TEXT COMMANDS

### Initial Text Defaults

When the VT125 graphics processor first powers up, many of the Text commands listed in this section have default values assigned. The defaults allow the graphics processor to respond immediately to many of a novice ReGIS user's commands. General applications should include text command specifications at the beginning of each graphic image to ensure the needed state of the graphics processor at the time of image generation. The defaults are: T[+9,+0] (S1, H2, S[9,20], M[1,2], D0, I0).

### Text

Format: T 'text'

This is the basic form of the text command. It can be used when the states of the options are known to be correct.

### Text Character Cell Size

Format: T(S<size number>) '<text>'

This command selects a character cell size from a standard set of sizes that are multiples of a predetermined width of 9 and height of 15. The sizes are numbers in the range of 0 to 16. The resulting character cells are the size number times 9 pixels wide and the size number times 15 pixels high, except for size 0 characters that are 5 X 10 pixels in size, and size 1 characters that are 9 X 20 pixels in size. The size 1 characters are close in size and vertical spacing to the VT100 characters.

The rest of this section refers to the region defined by a bit in the character cell memory as a unit, because the commands in this section allow text that has more than one pixel controlled by each bit.

A standard character cell is 9 units wide by 15 units high. The character that is displayed in the cell is 8 units wide and 10 units high. (80 pixels are stored for each character in the graphics processor's character memory.) This standard combination of cell and character sizes results in one horizontal unit and five vertical units of spacing between characters.

Because of the default character cell size that is selected with this command, there is room for 9 horizontal units of pattern in the default cell but there are only 8 units of information available. To fill the ninth space, the graphics processor copies the pixel from the first position of the character pattern. (See Figure 5-10) Most of the characters of character set 0 (the permanent set) are only seven pixels wide and are right justified in their pattern cells. Therefore, the first pixel of each scan of the character is dark. When this first pixel gets copied to the ninth position in the cell, the ninth position is also dark. The result is seven pixel wide characters that are spaced two pixels apart.

Because the first pixel of a cell is copied into the ninth position, continuous patterns like the underline of character set 0 can be drawn. If a character has the first pixel visible but you do not want that pixel repeated, use the explicit character specifiers as shown in following command descriptions to obtain an eight pixel wide character cell instead of the default nine pixels of this command.

All of the values that are set by default in this command can also be set or modified by using the following group of explicit character specifiers together. This group of specifiers also illustrates the parameters that are set by the S command. The pairs of commands shown in Table 5-5 are equivalent and provide nine pixel wide character cells:

**Table 5-5 Text Size Command Equivalents**

	Character Spacing	Character Cell Size	Pixel Multiplier
T(S1)	= T [+9,+0]	(S[9,20]	M[1,2])
T(S4)	= T [+36,+0]	(S[+36,+60]	M[4,6])
T(S16)	= T [+144,+0]	(S[144,240]	M[16,24])

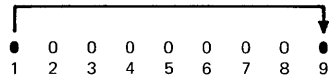

MA-9466

Figure 5-10 Copying Pixel 1 to Pixel 9

ABCD

TI[+36,+01(S[32,60],M[4,61])'ABCD'

A  
B  
C  
D

TI[+32,+28]'ABCD'

A  
B  
C  
D

TI[-32,+44]'ABCD'

MA-9442

Figure 5-11 Text Character Spacing

## Text Character Height Multiplier

Format: T(H <multiplier>)

Use this command to select a non-standard character aspect ratio when using the Text Character Size command. <multiplier> is an integer from 1 to 25 which multiplies the 10 pixel height of the character pattern after the Character Size command sets the standard width. The largest multiplier causes a character which is within 5 pixels of the largest character cell size possible (255). (Larger values cause distorted and incomplete characters.)

## Text Character Spacing

Format: T[<position>] (<options>)

The spacing option follows the T command keyletter before any parenthesized options. It is a relative position specifier that indicates the distance and direction that the active position must move from the top left corner of one character to the top left corner of the next character. See Figure 5-11. Use this command with the Text Character Cell Size and Text Pixel Multiplier commands. The default spacing used with the S<integer> command is [+9,+0] which leaves one pixel between characters and keeps all characters on the same horizontal line.

The spacing option values are always relative and the option always sets both x and y every time it is used even if a value is omitted. Therefore, an omitted value causes that dimension of spacing to be set to relative 0, which means draw the next character at the same x or y position. For horizontally arranged text, the y value can be 0 or omitted. If the x value is also 0 or omitted, the following characters are all drawn in the same location (overstriking). (Note: For occasional overstrikes, use the Backspace control character in the text string.)

## Text Pixel Vector Spacing

Format: T <pv>

This nonparenthesized command uses pixel vector numbers to indicate directions of offset for characters. The amount of offset is determined by the size of the characters, and is one half of the given character's size in the direction of movement. The pixel vector multiplier does not apply. The vector direction is relative to the character baseline so this command is affected by

the Tilt Direction command. The pixel vector numbers can appear anywhere in a command except in quotes.

From the pixel vector directions given in Figure 5-12, T6 makes the following characters appear as subscripts, moved down from the current baseline by one half character height. T2 produces superscripts, and T44 moves a character back one complete character width to produce an overstrike. Offsets up and down from the character baseline must be followed by reversing offsets to put the rest of the characters back on the baseline.

### Text Character Cell Size

Format: T(S[<width in pixels>,<height in pixels>])

This sets the size of the area on the screen that is drawn by a single character T command. The maximum area specifier is [255,255]. (Larger specifiers are counted modulo 256.) Use this command with the Character Spacing and Text Pixel Multiplier commands to select non-standard character sizes and aspect ratios. A cell with room for 8 horizontal units and 15 vertical units is some multiple of [8,15]. (Compare to sample S option in Character Cell Size.)

See Figure 5-13. If the cell is smaller than the character that appears in it, the character is cut off at the right and bottom edges. If the cell is larger than the character that appears in it, the character repeats as many times as possible across the width of the cell, and the alphabetically next characters in the character set appear sequentially and repeatedly along the remaining height and width of the cell.

### Text Pixel Multiplier

Format: T(M[<width mult>,<height mult>])

This command specifies how many pixels in the display will be controlled by each pixel in the character pattern. The command multiplies the pixels of each character by the given width and height multipliers. The maximum multiplier is [16,127]. (Larger specifiers set the multipliers to the maximum values.) Use this command with the Character Spacing and Character Cell Size commands.

If a character cell has been selected that is 18 x 30 pixels in size, for example, pixel multipliers of [2,3] must be selected to adjust the character

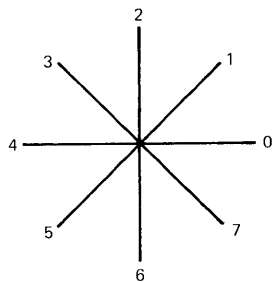

MA-9464

Figure 5-12 Pixel Vectors

**ZFTT**

T [+36, +0] (S [32, 60], M [7, 10]) 'ABCD'

AAAA BBBB CCCC DDDD  
 BBBB CCCC DDDD EEEE  
 CCCC DDDD EEEE FFFF

T [+36, +0] (S [32, 60], M [1, 2]) 'ABCD'

**ABCD**

T [+36, +0] (S [32, 60], M [4, 6]) 'ABCD'

MA-9443

Figure 5-13 Text Character  
 Cell Size

to fill the cell. This example is a standard size. Many other combinations are possible. See Figure 5-13 (above) for more examples.

### Text String and Character Tilt Direction

Format: T(D<direction angle> S<size>)

This command affects different parts of the display depending on how it is formatted. The simplest form of the command is given above; this controls the tilt of the baseline for a text string. A text string can be tilted at any 45 degree interval (either positive or negative), on a 360 degree compass. (See Figure 5-14.) Compass values other than 45 degree intervals are translated as the nearest lower 45 degree increment. The Size command can be a repeat of the last chosen value or a new value but must be included to provide correct baseline direction and character spacing. Characters reading from left to right are not tilted if the baseline is at 0 degrees, and they are upside down if the baseline is at 180 degrees. (See Figure 5-15.) You may need to adjust the size for tilted characters because ReGIS does not control the scaling between horizontal or vertical and diagonal characters.

The next form of the command controls both the text string baseline tilt, and the tilt of individual characters in the string.

Format: T(D<string tilt> S<size> D<character tilt>)

By including a Size command in the option list, you use the same Direction keyletter twice. The first value sets the tilt for the complete text string, and the second value sets the tilt for each character in the string. See Figure 5-15.

The D command works by setting the tilt of characters. Then the Character Size <number> command uses the angle specified by D to calculate the spacing needed to position the tilted characters on a common baseline. (Character Size [x,y] must have explicit spacing information and cannot calculate it from the D value.) After spacing information is calculated by the S<> command, another D command changes the character tilt again to the final value before drawing starts.

Some display combinations can also be produced with other commands. For example, many values of string direction other than 45 degree intervals can be

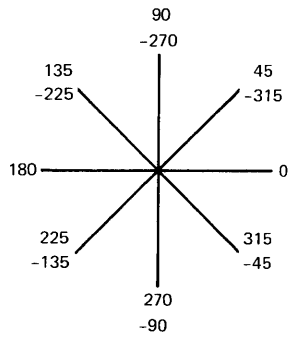

MA-9465

Figure 5-14 360 Degree Compass

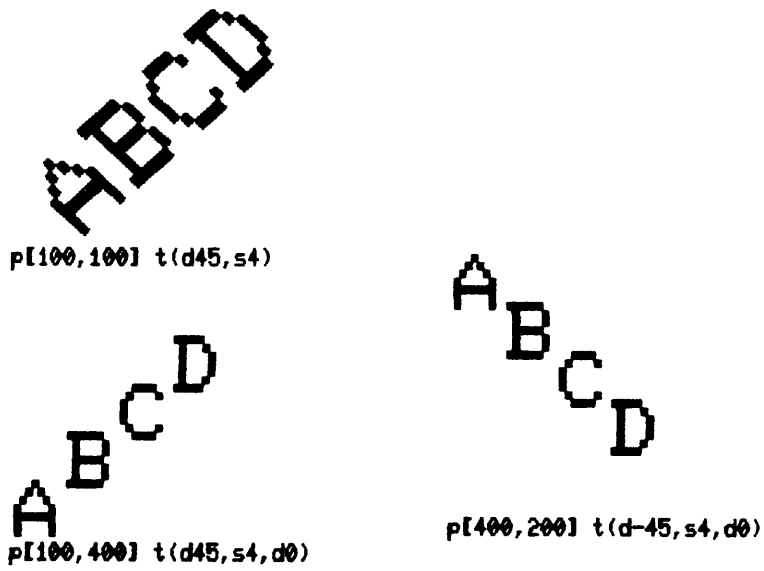

MA-9449

Figure 5-15 Text String and Character Tilt Direction



Table 5-6 Italic Tilt Values

Italic Specifier	Approximate Angle
<u>+0</u>	<u>+0</u>
<u>+1</u>	<u>+2</u>
<u>+2</u>	<u>+3</u>
<u>+3</u>	<u>+5</u>
<u>+4</u>	<u>+6</u>
<u>+5</u>	<u>+7</u>
<u>+6</u>	<u>+8</u>
<u>+7</u>	<u>+10</u>
<u>+9</u>	<u>+13</u>
<u>+11</u>	<u>+15</u>
<u>+13</u>	<u>+20</u>
<u>+19</u>	<u>+25</u>
<u>+31</u>	<u>+45</u>

drawn with the explicit spacing command. And if the string tilt is 0, the Italic command gives better results and more values of character tilt without requiring a spacing command.

#### Text Italic Tilt

Format: T(I<Italic degrees>)

The Italics command tilts the vertical lines of individual characters without tilting the horizontal lines. Table 5-6 lists the values of tilt that are available in the VT125 and the specifiers needed to get them. Positive specifiers tilt the characters to the left according to the compass directions in Figure 5-15 (above). Note that the actual angles of tilt are approximate, and smaller tilt angles may distort small characters. Specifiers between the listed values set the tilt to the next lower value. This command can be used with the D command. See Figure 5-16.

#### Select Text Character Set

T(A <character set number>)

This command selects the character set that is used for all text commands until another set is selected. The number can be 0, 1, 2, or 3. Set 0 is the default character set which is ASCII and cannot be changed. Sets 1, 2, and 3 are user loadable 95 character memories. (See Pattern Cell Controls section of this chapter.) If a character cell has not been loaded, it is displayed as a filled in block.

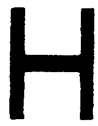

p[20,100] t(s8,i0)



p[350,100] t(s8,i-45)



p[500,100] t(s8,i22)

MA-9445

Figure 5-16 Text Italic Tilt

This command only selects a character set for display. See Pattern Cell Controls for the command that selects a character set for loading.

### Store and Restore Options

Format: T (<current options>) '<text>'  
(B) (<temporary options>) '<text>' (E)

All text options controlled by the T command can be saved as a unit and later restored to their saved settings. The (B) command saves the current text option values in the graphics processor's memory. You can make changes to one or more of the current options with another T command and display text with the changed options, and you can draw other graphic objects. Then, the (E) command restores the saved option values for the following text display. Only one set of options values can be saved at a time. This feature allows you to temporarily change the text display options without needing to respecify the original values when you return to them.

### Temporary Writing Controls

Format: T(W(temporary writing controls))

This command allows writing control options that only affect text drawn during this particular command. Usually, writing control options stay active for all following writing commands until they are respecified. The temporary writing controls command allows temporary changes to color specifiers, writing modes, etc, during the text command that they are in. The writing controls that are in effect for all commands except this particular text command stay unchanged. See the Writing Controls section for the formats of writing controls options.

Table 5-7 is the Text Command summary.

### WRITING CONTROLS

This section describes the attributes of intensity and pattern that pixels and shapes can have, and explains the commands that control the attributes.

### Initial Writing Control Defaults

When the VT125 graphics processor first powers up, many of the writing controls listed in this section have default values assigned. The defaults allow the graphics processor to respond immediately to many of a novice ReGIS user's commands. General

**Table 5-7 Text Command Summary**

---

T	{	(S <size number>)	}
	{	(H <height>)	}
	{	[<spacing>]	}
	{	(S [<width in pixels>,<height in pixels>])	}
	{	(M [<width pixel multiplier>,<height pixel multiplier>])	}
	{	(D <direction angle>)	}
	{	(D <string tilt> S <size> D <char tilt>)	}
	{	(I <italic degrees>)	}
	{		}
	{	(A <pattern set number>)	}
	{		}
	{	((B) <temporary attributes block> (E))	}
	{		}
	{	(W(temporary writing controls))	}

---

applications should include writing control specifications at the beginning of each graphic image to ensure the needed state of the graphics processor at the time of image generation. The defaults are: W(V, I(W), F3, M1, N0, P1, P(M2), S0).

**Writing Modes**

The four writing modes, Complement, Erase, Replace, and Overlay, can be used at any time, but only one at a time. They control the way pixels are placed in a graphic image, and their major effects are visible when a part of the image already exists.

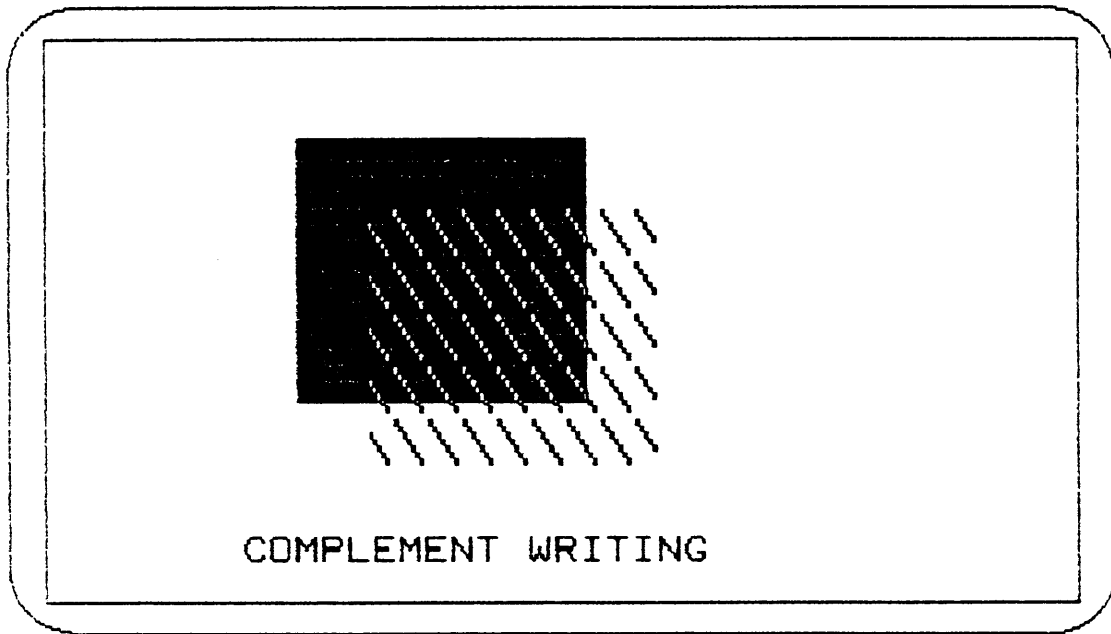

MA-9450

Figure 5-17 Complement Writing

Table 5-8 Complementing the Foreground

Initial Foreground Specifier	Specifier Bit Pattern	Complemented Foreground Specifier	Specifier Bit Pattern
I3	1 1	I0	0 0
I2	1 0	I1	0 1
I1	0 1	I2	1 0
I0	0 0	I3	1 1

### Complement Writing

Format: W(C)

During a write, complement the bit pattern of the foreground specifiers (see Foreground Planes) of the pixels present in the existing image wherever the pattern register (see Patterns) is 1 and do not change wherever the pattern register is 0. See Figure 5-17. Complement writing is generally reversible by repeating the same command. Complementing the foreground specifier gives the results shown in Table 5-8.

Use the Foreground Planes command to get other combinations with Complement writing.

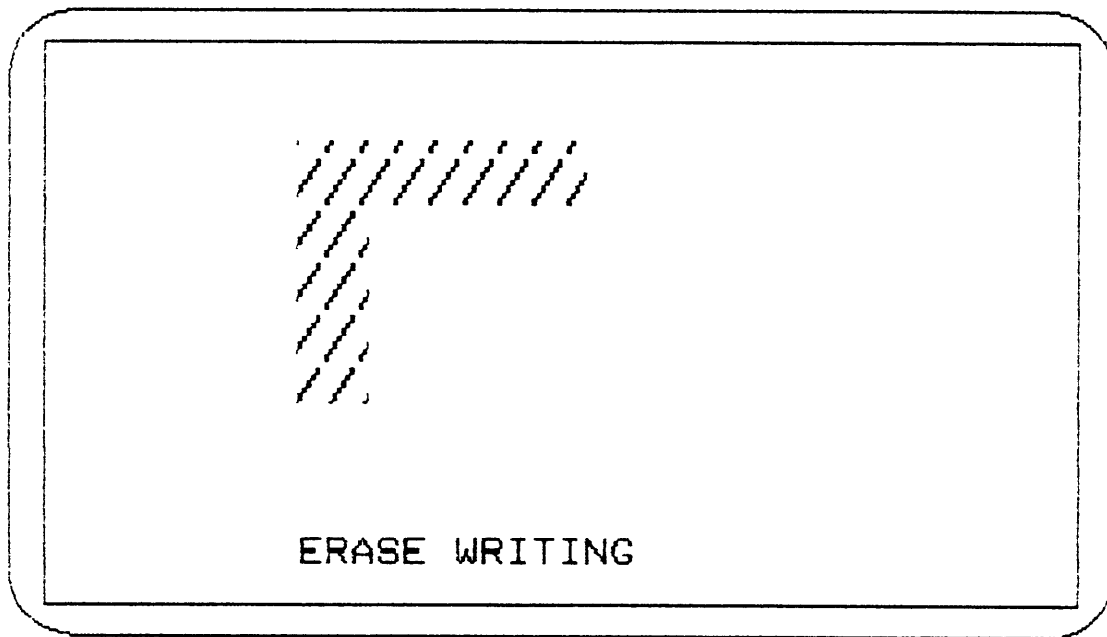

MA-9469

Figure 5-18 Erase Writing

Erase writing

Format: (E)

Write each pixel with the background specifier if negative writing (W(NØ)) is off, or write each pixel with the foreground specifier if negative writing is on. See Figure 5-18. This command does not use the pattern register.

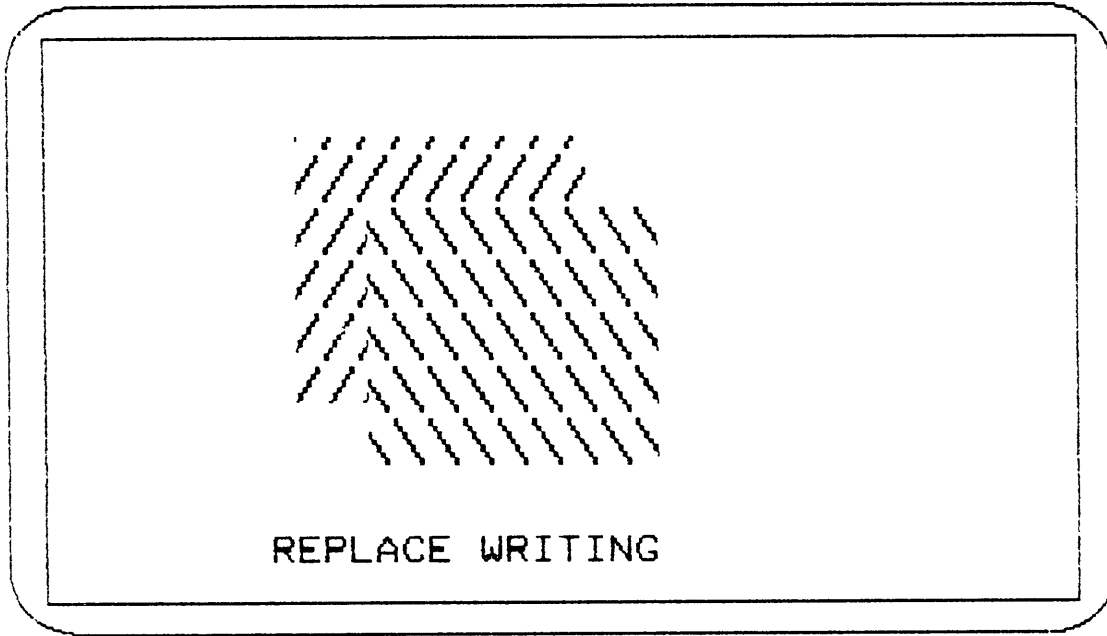

MA-9451

Figure 5-19 Replace Writing

Replace writing

Format: (R)

Replace the current image with a new image.  
\*Background areas in the new image and \* Areas where the pattern memory is  $\emptyset$  erase the parts of the current image that were in that area.

Figure 5-19 shows boxes written with replace writing in which part of the shaded area of the upper box has been replaced with the shading pattern of the lower box.

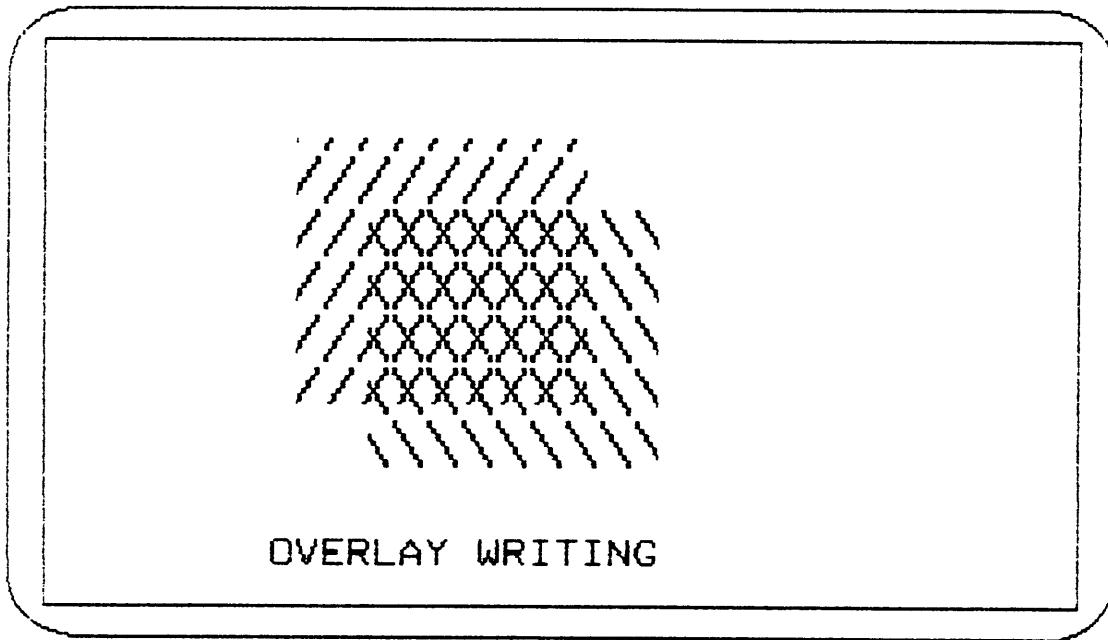

MA-9452

Figure 5-20 Overlay Writing

### Overlay writing

Format: (V)

Write a new image on top of the current image, wherever the pattern memory is 1, without erasing any part of the current image. Blank areas in the new image and areas where the pattern memory is 0 have no effect on the overwritten area. This is the default option in the VT125 graphics processor. Figure 5-20 shows boxes written with overlay writing in which part of the upper box is written with both its original pattern and also the new pattern of the lower box.

### Foreground Planes

Format: W(F <integer>)

<integer> = 0 = no planes  
1 = plane 1  
2 = plane 2  
3 = planes 1 and 2



Any pixel can have four choices of appearance because there are two bits of memory for each pixel in the graphics processor. This command gives you control over the individual bits for each pixel in writing commands. (Screen Erase always clears all bits.)

Each of the 196,608 pixels in the graphics processor has two bits in the display memory. Each bit is in one of two identical planes of bits that have addresses that correspond to the display's pixel addresses. See Figure 5-21. The graphics processor uses both bits when it displays each pixel.

The two bits hold an address that selects one of four intensities and colors that the graphics processor can display at one time. These intensities and colors are set with the Screen Map control and are stored in the Output Map. The address stored in a pixel's two bits controls which of the four intensities and colors that the pixel has on the display.

The Foreground plane command lets you write each of the bits individually by limiting the write commands to one plane or the other. This has three main applications:

1. Suppose you want to use complement mode (perhaps because its effects are reversible by repeating the same command) to change an object from I3 (Intensity 3) to I2. During complement writing, both bits are changed. When both bits change (see Figure 5-21), the object changes from I3 to I0. But turn off Plane 1 writing and only complement the low bit and you get I2. Or turn off Plane 0 writing, only complement the high bit, and you get I1 from I3.

Figure 5-21 shows the process of writing the graphic memory with pixels controlled by the writing commands. The writing commands select the individual pixels to be written, the pattern controls whether the selected pixel changes or not, and then the Foreground Planes command controls which of the two planes can be written. The four addresses that the two bits form in the planes are shown for pixels  $(x,y)$ ,  $(x,y+1)$ ,  $(x,y+2)$ , and  $(x,y+3)$  in the figure. These addresses point to the four values of intensity and color that are stored in the output map.

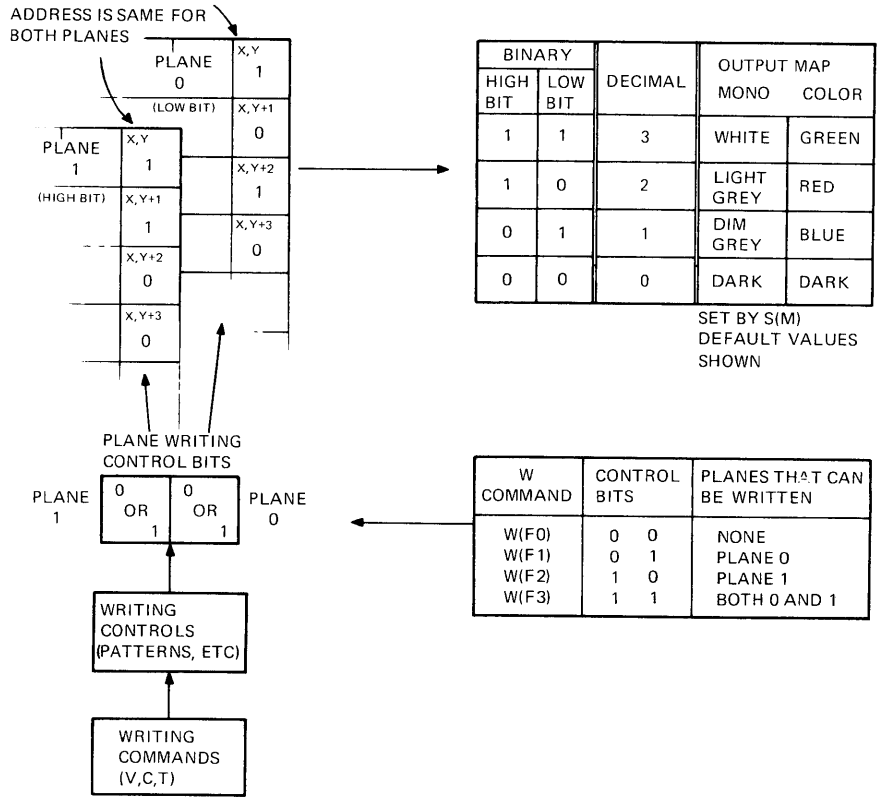

MA-9468

Figure 5-21 Foreground Planes and the Output Map

To select the right plane to write, see the figure. Complementing a pixel means that the two bits in memory for that pixel are changed to their opposite values. Complementing both bits means that if the intensity is I3, its complement is I0, and if the intensity is I2, its complement is I1.

Note the binary to decimal conversion and the output map in the figure. To change from I3 (White or Green) to I2 (Light Grey or Red) is a one bit change in Plane 0 with no change in Plane 1. But Complement changes the bits in both planes. By using the Foreground Planes command to turn off writing to Plane 1 (W(F1)), you can use the complement command to change pixels from I3 to I2.

Remember to restore writing to both planes when you finish single plane writing.

2. One plane can hold a fixed image, like a graph grid, and the other plane can hold overlays that you can write in replace mode without redrawing the grid.
3. Another application for the Foreground Planes command is the alternate display (including blinking) of two graphic images. The graphics processor takes a noticeable amount of time to draw most images into its memory. This drawing time makes blinking or other closely timed visual effects difficult to do. However, if you can afford to use only two colors or intensities in your images, you can use the two foreground planes as two separate graphic memories that can be drawn in with full pixel resolution.

### Foreground Intensity and Color

Format: W(I<integer>) or W(I(<letter>))  
or W(I(H<hue>L<lightness> S<saturation>))

This command selects the appearance of the graphic objects that are drawn after this command from a range of four values that were entered into the output map by the Screen Output Map Definition (S(M)) command. An integer specifier selects one of the four output map values. A letter or HLS specifier makes the graphics processor compare the specifier with the four values stored in the color output map. The integer specifier that was defined to hold the color output map value that is closest to the foreground definition then becomes the

foreground value. This command cannot store a value in the output map but only selects from the available choices. If the letter or HLS specifier in this command is too different from the current output map values, the graphics processor may not find a close enough value and may give unpredictable results.

Any pixel can have any of the four values of monochrome intensity (for the internal monitor) and color hue, lightness, and saturation (HLS for the external color monitor). However, one value in the map is used as the background specifier (see Screen Background (S(I) and Screen Erase (S(E))), so any object drawn with the background color or intensity should be drawn on top of another object or it will not be visible.

Any pixel can have four choices of appearance because there are two bits of memory for each pixel in the graphics processor. See the Foreground Planes command for control over the individual bits for each pixel.

The default value is I3 or I(G) or I(L100).

#### Pixel Vector Length Multiplier

Format: W(M <multiplier>)

This command sets the number of pixels that pixel-related Position and Vector commands move or draw in one step. The default and minimum value is 1 pixel, and the maximum is 255. (Larger values modulo 256; 0 is set to 1.)

#### Negative writing

Format: (N 1) = negative on (N 0) = negative off

Negative writing inverts the effect of the pattern memory. For writing commands that use the pattern memory, where the memory is 1, the background is written, and where the memory is 0, the foreground is written.

#### Shading

The shading commands let you fill the inside of a graphic object with the same command you use to describe the outline of the graphic object. When shading is on, the vector and curve commands operate as usual. But starting at each pixel on the vector or curve path, the graphics processor draws a line to the shading reference line. The shading reference line is the horizontal line whose Y-coordinate is specified when shading is turned on. The default shading reference is the current Y-coordinate. You can specify a different shading reference line in the shading command.

The default writing pattern used when writing the shading lines is the current writing pattern, which also has a default value of all 1's. You can specify a text character from any of the graphic processor's character sets to be used as the shading pattern. Such shading can be used for area fill, but the graphics processor does not automatically ensure that arbitrary areas are completely and correctly filled; you must ensure that the correct reference lines are specified to get the shading effect that you want.

Shading with a pattern can provide density or "half-tone" effects. If you are limited to two intensity values, as for example with the LA34-VA hard copy printer, you can get grey scale effects by shading with different density characters. Use the Character Cell controls to define a set of characters that have different numbers of pixels dark, and use them as shading characters. The same technique can let you mix colors at the pixel level. Define characters that have the same number of pixels dark but that have the pixels offset from character to character. Then overlay write the graphic object with the different shading characters using a different foreground color for each character.

#### Shading On or Off

Format: W(S1) = shading on  
W(S0) = shading off

This command turns shading on for area fill. The current Y-position is the shading reference line unless you include the reference line command, below. The S(E) command turns off shading and sets the shading reference line to the current position.

#### Shading character

Format: W(S 'shading character')

Turn shading on (same as S1) and use the shading character in single or double quotes to provide a particular pattern for area filling. (See Patterns.) Use the Text command to select a character size or character set before specifying the shading character. When characters from the character set are being used as a shading pattern, only the first eight (of ten) lines of character pattern are used.

#### Shading reference line

Format: W(S [,<y-position>])

Including a Y position in a shading command sets the shading reference line to the needed position for proper fill of the graphic object to be drawn. This command is used with the Shading On or Shading

Character commands. Used by itself, this command turns shading on and clears the shading character (same as S1).

The shading is drawn from pixels on the outline of a graphic object to the reference line. If that line is in the wrong place, the shading can cover parts of the graphic object. For example, a reference line that is above a circle will cause a solid U shape to appear. The reference line needed for a circle is in the middle, where the x dimension is largest.

Other graphic objects can be more difficult to shade, particularly if they are concave on their left or right sides. See Figure 5-22. A general rule is to draw such objects in two or more sections, putting the shading reference line above one section and below the other. Shading patterns are always aligned everywhere in the display, so objects can appear continuously shaded even if they are generated in separate operations.

Shading with patterns (using the W(P) commands) gives horizontal pattern lines. This is because the command to shade to a reference line actually draws a series of vertical vectors to that line, using the pattern.

The S(E) command turns off shading and sets the shading reference line to the current position.

### Patterns

Patterns allow you to vary the appearance of lines and shaded areas in a graphic object. The typical drawing process sets all pixels in the graphic object either to one of the three foreground intensity (or color) values or to the background value. A pattern keeps some of the pixels of the graphic object at the background value while the rest change to a foreground value. The pattern does not have to be related to the graphic object's outline.

Patterns are stored in a memory which is then read during a write operation to control the appearance of pixels in graphic objects. For example, a vector command may write a series of pixels in a line on the display. As the pixels are written, the pattern memory is read bit by bit to determine whether a corresponding pixel should have the foreground or background intensity. The shading pattern is also controlled by the pattern memory.

The memory is 8 bits wide, and its default contents are all 1's (pattern P1). Other patterns can be loaded into the pattern memory, including standard patterns selected by number (Select Standard Pattern), or your own pattern loaded by its bit pattern (Specify Binary Pattern).

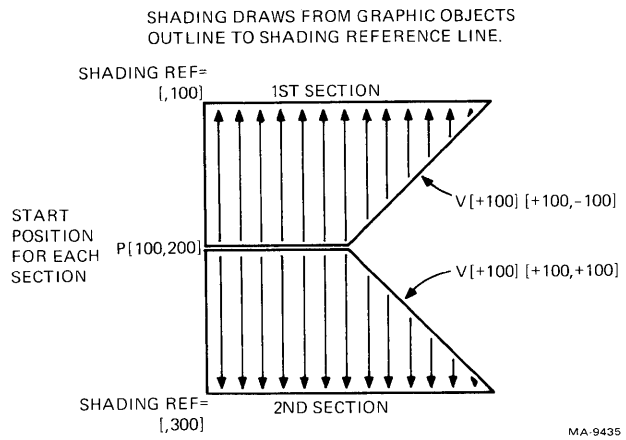

Figure 5-22 Selecting a Shading Reference Line

### Select Standard Pattern

W(P <pattern number>)

This command selects a pattern for drawing the outlines of graphic objects. The patterns that have been included in the VT125 graphics processor are listed in Table 5-9.

(Patterns 6 through 9 are reserved for future standardization, but are displayed in the VT125 as separated dots so they are visible.)

**Table 5-9 Standard Patterns in the VT125**

---

P0 = 00000000  
P1 = 11111111  
P2 = 11110000  
P3 = 11100100  
P4 = 10101010  
P5 = 11101010  
P6 through P9 = 10001000

---

### Specify Binary Pattern

W(P <binary pattern>)

A binary pattern is a two- to eight-bit pattern that you can set with 1's and 0's. When the graphics processor draws on the screen, bits that are set to 1 are drawn, and bits that are set to 0 appear as gaps in the line. (If negative writing is on, the effects of 1's and 0's are switched.)

A maximum of 8 bits can be specified for the pattern memory. During the drawing of graphic objects, groups of 2, 4, or 8 bits are repeated as full subunits. Table 5-10 illustrates the repeat methods.

**Table 5-10 2, 4, and 8 Bit Binary Pattern Repeats**

---

Pattern (Bit #)	Pattern Repeated (spaces for clarity)
12	12 12 12 12 12 12 12 12...
1234	1234 1234 1234 1234...
12345678	12345678 12345678 12...

---



Groups of 3 are repeated twice and then followed by the first two bits of the group before starting again. Groups of 5, 6, or 7 are displayed once and then followed by the first 3, 2, or 1 bits of the group before starting again. Table 5-11 illustrates the repeat methods.

**Table 5-11 3, 5, 6, and 7 Bit Binary Pattern Repeats**

Pattern (Bit #)	Pattern Repeated (spaces for clarity)
123	123 123 12 123 123 12 123...
12345	12345 123 12345 123 12345...
123456	123456 12 123456 12 123456...
1234567	1234567 1 1234567 1 1234567...

For example, P1100 draws lines dashed with equal gap and mark spacing. P11100111 draws dashed lines with marks three times as long as gaps (because of the pattern repeat). P101 draws a pattern 1011011010110110 (note that the 3 bit pattern is not cyclic over all groups of 3 bits).

For more variations, use the Pattern Multiplier command.

#### Set Pattern Multiplier

W(P (M <pattern multiplier>))

The pattern multiplier sets the number of pixels that are affected by each bit in the pattern memory. The minimum value is 1 pixel and the maximum value is 16. (0 does not change the setting. All other values set the multiplier to 16.) Figure 5-23 shows the pattern memory and multiplier in operation. The default multiplier is 2 so the interaction of the write modes and some patterns does not prevent graphic objects from appearing the way you want. This makes odd-y simulation work to let a square have the same number of addresses in both axes.

#### Custom Writing Control Definition

Format: W(W<i>(P<j>,N<k>))

This command defines the values that replace a specific value of current contents at a pixel location. The contents of the pattern memory selects which of the two values is used. The

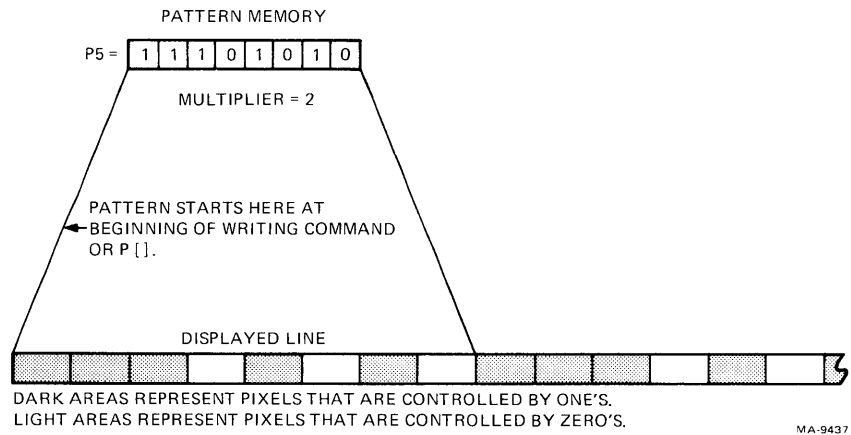

Figure 5-23 Pattern Memory and Multiplier

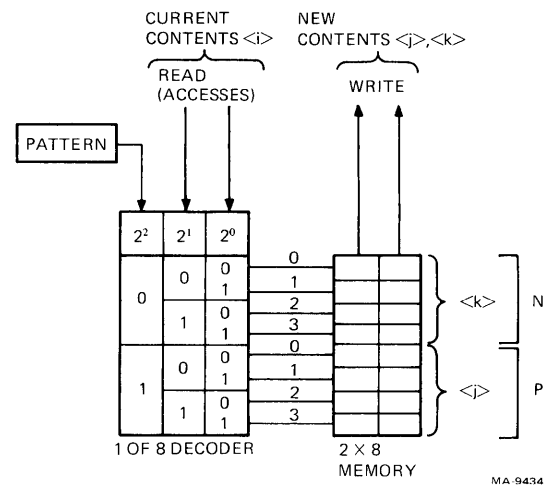

Figure 5-24 Custom Writing Control Command

command must be expanded to define the complete writing control. See below. Numbers are in the range 0 to 3.

<i> =  
current pixel contents (repeat for 0 through 3).  
<j> =  
writing value (0 - 3) if pattern memory bit is 1.  
<k> =  
writing value (0 - 3) if pattern memory bit is 0.

The VT125 has several writing controls that define the effects of a writing operation on the display. Standard writing controls provided include, for example, Complement and Overlay.

Each of the standard writing controls is a predefined shorthand use of the W(W) command. You can create your own writing control to get the effect you want. The W(W) command lets you define writing actions for single pixels based on every possible combination of bit plane and pattern memory contents.

Figure 5-24 shows that the hardware associated with the W(W) command is a one of eight decoder and an eight by two bit memory. The decoder has two inputs. The current pixel in the display bit map supplies the two low bits. The current bit in the pattern memory supplies the high bit. The eight outputs from the decoder select eight possible writing choices for the current pixel.

The W(W) command loads the eight by two bit memory with your choices for new information to write into the current pixel location. All the numbers in the command represent two bit numbers in the range 0 to 3. The command introduction is W(W. The next number <i> is the current pixel value. All four possible current pixel values are inputs to the 1 of 8 decoder, so the command must be repeated four times to change the complete memory. The rest of the command is (P<j>,N<k>). P and N are keyletters for the contents of the pattern memory. <j> and <k> are numbers representing the new information to be written. For a given <i>, if the current bit of the pattern memory is 1 (P for positive), then <j> is the value that is written. If the current bit of the pattern memory is 0 (N for negative), then <k> is the value that is written.

For example, if the current pixel is 0 and you want to change it to 3 if the pattern memory bit is 1, and leave it 0 if the pattern memory bit is 0, the command is W(W0(P3,N0)).

W(R), W(C), W(V), W(E), W(N)M, W(F<n>) and W(I<n>) are actually shorthand expressions for forms of the W(W) command. For example, the equivalent of W(C) is:

W(W Ø(P3,NØ) 1(P2,N1) 2(P1,N2) 3(PØ,N3))

W(F1,R) is:

W(W Ø(P1,NØ) 1(P1,NØ) 2(P3,N2) 3(P3,N2))

W(F3,V,I2) is:

W(W Ø(P2,NØ) 1(P3,N1) 2(P2,N2) 3(P3,N3))

Specifying any shorthand form sets the complete map to the appropriate value. When you use W(W), only those choices you specify are filled in. Unspecified values remain as previously set.

Table 5-12 is a summary of the Writing Controls.

Table 5-12 Writing Controls Summary

W {	(C)	}	Complement	
{	(E)	}	Erase	
{	(R)	}	Replace	
{	(V)	}	Overlay	
{	(F <foreground planes>)	}	Ø = no planes	
{		}	1 = plane 1	
{		}	2 = plane 2	
{		}	3 = planes 1 & 2	
{	(I Ø or (D) )	}	Foreground	
{	1 (R) )	}	Intensity	
{	2 (G) )	}	Dark	or Dark
{	3 (B) )	}	Dim grey	Red
{	(C) )	}	Light grey	Green
{	(Y) )	}	White	Blue
{	(M) )	}		Cyan
{	(W) )	}		Yellow
{		}		Magenta
{		}		White
{	or	}		
{	(I (H <hue angle>	}		
{	L <lightness percent>	}		
{	S <saturation percent>))	}		
{	(M <multiplier>)	}		

Table 5-12 Writing Controls Summary (Cont)

---

{ (N 1)	}	= negative on
{ (N 0)	}	= negative off
{	}	
{ (S 1)	}	= shading on
{ (S 0)	}	= shading off
{ (S [,shading reference])	}	
{ (S 'shading character')	}	
{	}	
{ (P <binary pattern>)	}	Enter pattern
{ (P <pattern number>)	}	Use VT125 pattern
{ (P (M <pattern multiplier>))	}	
{	}	
{ (W<i>(P<j>,N<k>))	}	Define write control

---

**SCREEN CONTROLS**

Screen controls are the commands that affect the complete screen of the VT125 at the same time. The Screen Controls section explains the controls for the positioning and addressing of the complete image, the color and background of images, timing of actions, and the production of hard copy output. All screen control commands begin with S.

**Initial Screen Control Defaults**

When the VT125 graphics processor first powers up, many of the screen controls listed in this section have default values assigned. The defaults allow the graphics processor to respond immediately to many of a novice ReGIS user's commands. General applications should include screen control specifications at the beginning of each graphic image to ensure the needed state of the graphics processor at the time of image generation. The defaults are: S[0,0] (A[0,0][767,479], I(D), S1, T0). (See below for M defaults.)

**Screen Scrolling**

Format: S<pv> or S[<position>]

A window (represented by the display screen of the VT125 terminal) moves around the screen image. The window moves its top left corner by a relative amount if the specifier is a relative position or a pixel vector, or to an absolute position (measured from the origin) if the specifier is an absolute position. Pixel multipliers apply if the pv form is used, and the origin is determined by the screen addressing option if the position form is used. (See the Position section above, and Screen Display Addressing below.) Display addresses stay with the image so the image stays in the same position relative to the origin. See Figure 5-25.

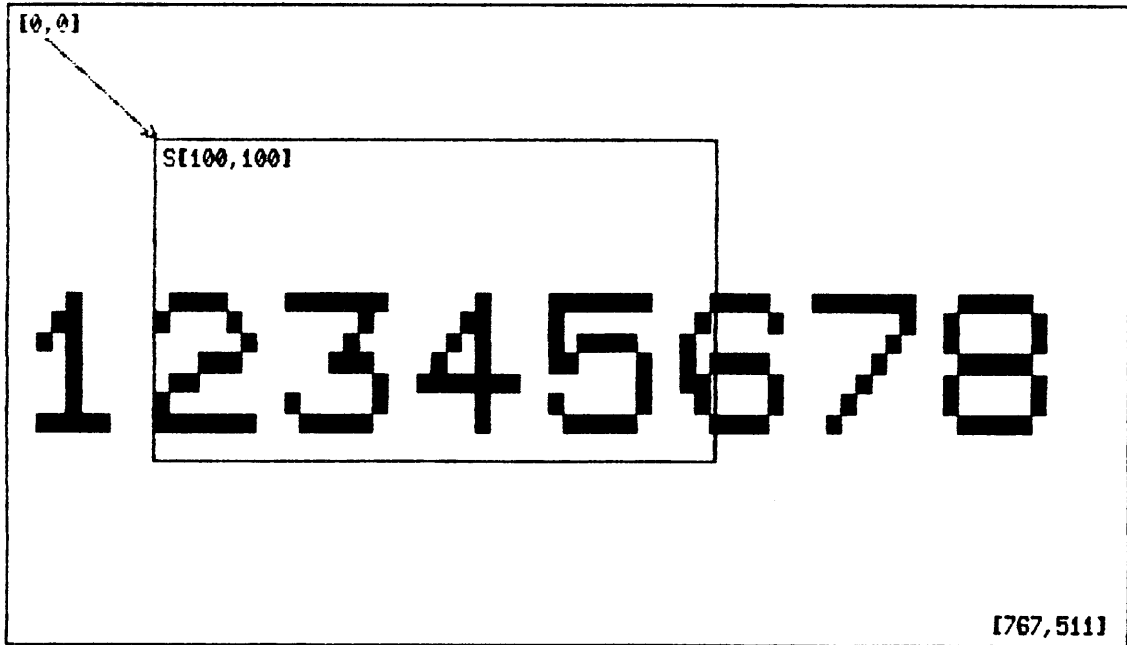

DISPLAY WINDOW'S TOP LEFT CORNER MOVES TO ADDRESS [100,100]. SCREEN SCALE=2

MA-9433

Figure 5-25 Scrolling the Display Window

If the Screen Scale command (below) changes the display of an image, this command moves the display window to allow any part of the image to be seen. Also, the image scrolls through an address space of 256 pixels vertically (represented by 512 addresses for odd-Y simulation) and wraps from top to bottom. The visible area is only 240 pixels (or 480 addresses) so vertical scrolling allows all of the image to be seen. The image wraps horizontally at pixel (and address) 768.

### Screen Display Addressing Definition

Format: S(A[<position>][<position>])

The addressing option is a compatibility feature that lets the VT125 display graphic images that are created for other ReGIS devices that have different resolutions or address orientations. Use a host system's software to do scaling (size) transformations and maintain the performance of the graphics processor. Scaling transformations done by the graphics processor have roundoff errors, resulting distortions, and generally produce smaller images than expected. Axis transformations (for example, moving the origin to the lower left corner) may be done by the graphics processor because they do not have much effect on the performance of the graphics processor and do not cause distortions or size changes.

NOTE: Pixel vector directions do not change with the addressing option.

The first <position> is the address you want the upper left hand corner of the display to have, and the second <position> is the address you want the lower right hand corner of the display to have. If either or both <position> are missing or illegal (negative), the entire option is ignored and the display coordinates stay unchanged. The graphics processor defaults to a specification of A[0,0][767,479].

If the right margin value is smaller than the left margin value, the x coordinate increases to the left. If the bottom margin value is smaller than the top margin value, the y coordinate increases going up. See Figure 5-26. There are no absolute negative coordinates in ReGIS, so do not specify an addressing range that has negative coordinates.

The graphics processor uses odd-Y simulation. Odd-Y simulation means that although the vertical resolution of the graphics processor is 240 pixels,

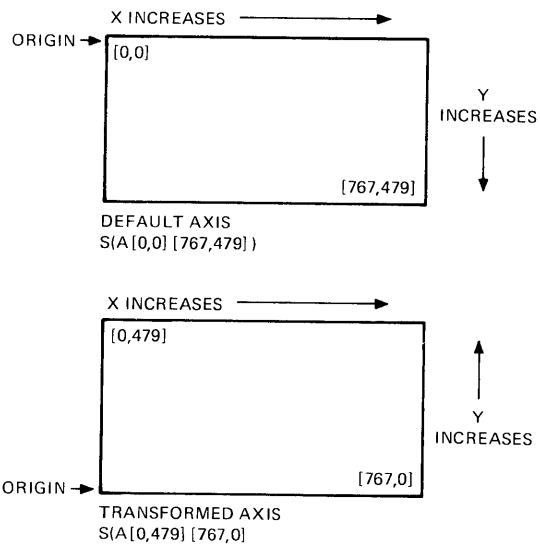

MA-9463

Figure 5-26 Axis Address Transformation

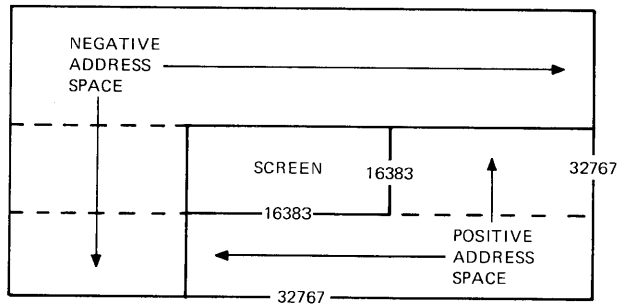

MA-9467

Figure 5-27 VT125 Addressing Range



**Table 5-13 Wrap Address Formulas**

---

Horizontal wrap =  
    (X-address option specifier X 4096/767) - 1  
Vertical wrap =  
    (Y-address option specifier X 4096/511) - 1

---

each pixel can be addressed by both an even number and the next higher odd number. This system allows compatibility with higher resolution displays and lets a given number of addresses in the x direction be the same physical length as the same number of addresses in the y direction.

For compatibility with future devices that have a larger displayable area than the graphics processor's screen, and to allow proper computation of graphic objects that partially extend into the borders of the screen area, ReGIS does not reject addresses that are outside the area of the displayable screen. The VT125 has a computing address space with full resolution that extends at least one full screen size in each direction (see Figure 5-27) provided that the address option specification is less than [16383,16383]. If no computing address space is needed outside the displayable screen, the address option specification can be as large as [32767,32767].

Beyond a certain address, which varies according to the address option specification, the graphics processor wraps graphic objects into the opposite side of the screen. Wrap addresses greater than 32767 are invalid. The wrap addresses can be calculated with the formulas in Table 5-13.

The Current Position as reported by the Report command is given in the coordinates set by this option. If a command has moved the cursor into the address space above or to the left of the screen, it is in "negative" address space. ReGIS cannot use negative addresses but the graphics processor reports the location of the current position in the form: 65536 + negative location. For example, a position 100 pixels to the left of [0,0] is computed as 65536 + (-100) = 65436. You cannot use this form to address the negative address space. Only relative movements from positive addresses can move the current position in the negative address space. The graphics processor's ability to compute locations in the negative address space prevents distortions or improper offsets at the negative boundaries. It cannot be used to create images for display.

When the addressing option is set to be any value except the default, integer scaling is used so that there is a constant integral relationship between the number of pixels that are displayable on the screen and the number of pixels that can be addressed by the coordinates that are selected. The result is that images prepared on low resolution devices transfer to other low resolution devices with constant interval step sizes that may waste up to half of the receiving device's display area.

## Screen Erase

Format: S(E)

Sets the complete screen area to the background intensity and color value that was selected by the Screen Background Definition (S(I)) command from the range of values in the output map set by the Screen Output Map Definition (S(M)) command. The current cursor position is not changed. Shading is turned off and the shading reference line is set to the current position. No other writing controls are affected. Any curve interpolation is terminated and all (B), (S), and (E) coordinate blocks are cleared. The contents of the output map (see Screen Output Map) are unchanged.

The E keyletter has a restriction in its formatting with other commands. ReGIS understands a string of numbers followed by E to mean exponential (scientific) notation. Therefore, a comma is necessary in the command S(I $\emptyset$ ,E) to cause a screen erase to intensity  $\emptyset$ .

## Screen Hard Copy Output

Format: S(H (P[<position>]) [<position>][<position>])

Generate a hard copy image of the screen area within the rectangle defined by the two position specifiers. If only one position specifier is given, that position and the current cursor position define the rectangle. If no position specifiers are given, the whole visible screen is output. The output image is scaled as the screen is scaled by the S(S) command, and the range of addresses printed is defined by the two position specifiers.

S(H(P[<position>])) is a command that specifies the location of the upper left corner of the hard copy image on the paper. The position is measured from

the left margin at the current vertical print head position. The value set by the P option stays the same until it is changed by another P option. The default position for hardcopy output is [50,0] to horizontally center the image on 8.5 inch paper. Unless the P[<position>] option is followed by other position arguments, it only sets the image corner location without causing a hard copy printout. If it is followed by arguments or another H keyletter, it causes a printout.

See the Media Copy control sequence in the Received Character Processing chapter under VT125 Communication and Graphic Control Sequences. With Media Copy, the hard copy image output can be sent either to the auxiliary port for printing, or to the host for storage.

NOTE: Entering and exiting SET-UP cancels a Hard Copy command.

Most printers can only display two intensities, on and off. The VT125 can display four monochrome intensities. To generate hard copy output, the VT125 puts a dot wherever there is a non-zero intensity according to the monochrome output map. See Shading in Writing Controls for a method for getting grey scale hard copy.

### Screen Background Definition

Format: S(I<integer>) or S(I(<letter>))  
or S(I(H<hue> L<lightness> S<saturation>))

This command selects the appearance of the background. The background is the intensity or color that the screen has when it is erased (S(E)) or when a graphic object is written that specifies background writing. The background is selected from a range of four values that were entered into the output map by the Screen Output Map Definition (S(M)) command. An integer specifier selects one of the four output map values. A letter or HLS specifier makes the graphics processor compare the specifier with the four values stored in the color output map. The integer specifier that was defined to hold the color output map value that is closest to the background definition then becomes the background value.

This command cannot store a value in the output map but only selects from the available choices. If the letter or HLS specifier in this command is too different from the current output map values, the

Table 5-14 Integer or RGB Colors in the VT125

Color Name	RGB	HLS
Dark	D	L0
Red	R	H120 L50 S100
Green	G	H240 L50 S100
Blue	B	H0 L50 S100
Cyan (B+G)	C	H300 L50 S100
Yellow (R+G)	Y	H180 L50 S100
Magenta (R+B)	M	H60 L50 S100
White (R+G+B)	W	L100

graphics processor may not find a close enough value and may give unpredictable results.

The default value is I0 or I(D) or I(L0).

#### Screen Output Map Definition

Format:

S(M<n> (L<mono lightness>) (A H<hue> L<lightness> S<saturation>))

<n> is 0, 1, 2, or 3 to select the output map section that stores the definition.

(L<mono lightness>) is an HLS specifier with only the L or lightness specifier given, or a letter specifier. See Table 5-14. It selects the intensity of a given pixel on the monochrome monitor in the VT125 terminal. The four possible lightness values (dark, dark grey, light grey, white) are on a percent scale that is divided into four ranges: 0-24, 25-49, 50-74, 75-100. Any percentage within a range selects the lightness value for that range; for example, L65 selects the third value: "light grey". Values are truncated to their integer part, so 24.99 is in the 0-24 range while 25.00 is in the 25-50 range. H and S specifiers are ignored in the monochrome part of the command.

(A H<hue> L<lightness> S<saturation>) is an HLS specifier that selects the intensity of a given pixel of an external (Alternate) color monitor. Many different colors can be displayed using the HLS specifiers because the six bits of information that each output map holds for the color monitor can describe any of 64 combinations. See Figure 5-28 for an illustration of the range of hues available for different levels of lightness and

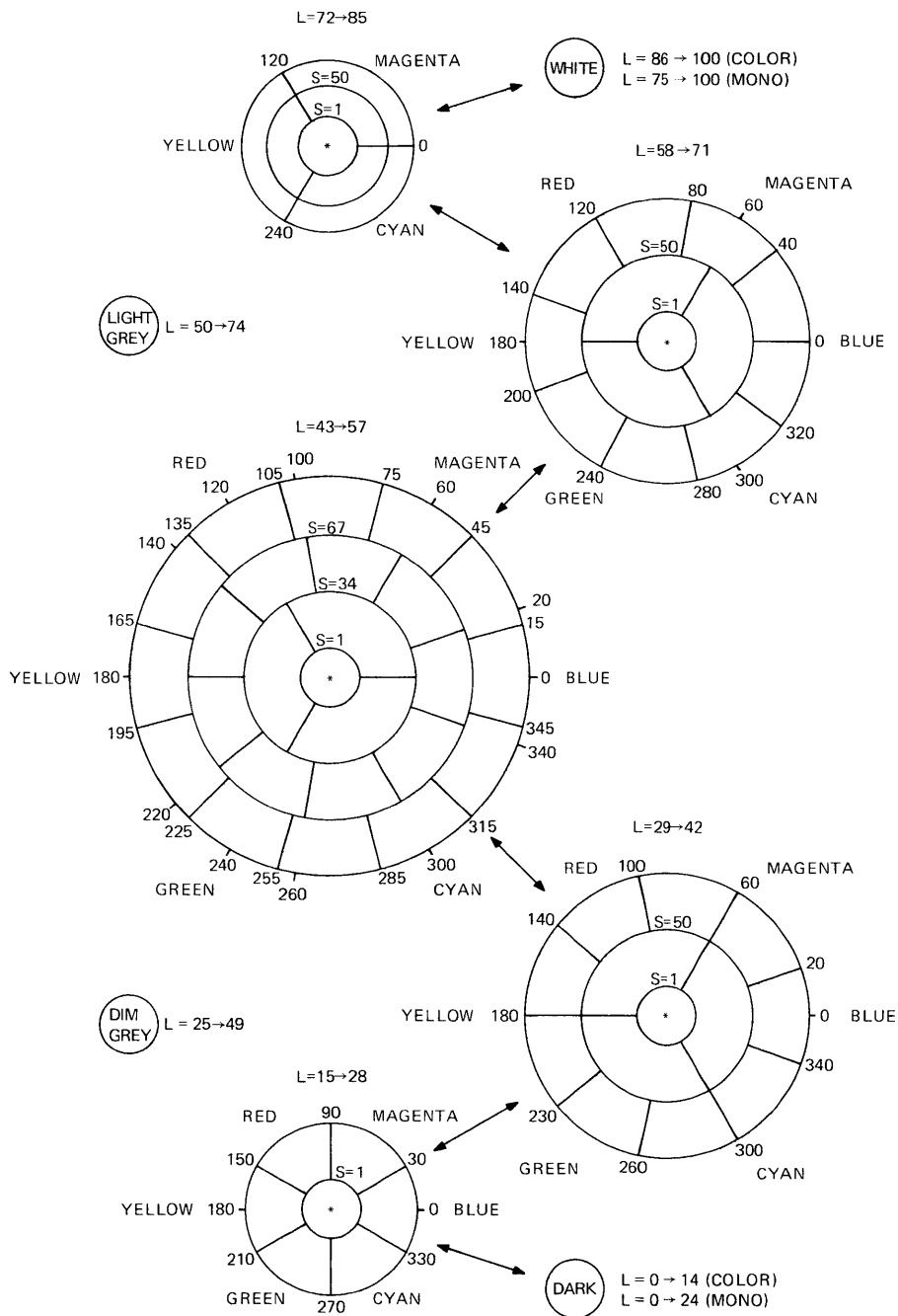

NOTE: DEGREE SPECS DEFINE THE SEGMENT FOLLOWING COUNTER CLOCKWISE.

\* THERE ARE FOUR MONO INTENSITIES. THEY ARE SHOWN IN SMALL CIRCLES.

MA 9431

Figure 5-28 Colors in the VT125

**Table 5-15 Default Output Map Values**

---

S(M0	(L0)	(A	L0)
1	(L25)	(A	H0 L50 S100)
2	(L50)	(A	H120 L50 S100)
3	(L75)	(A	H240 L50 S100) )

---

saturation. A more limited set of colors can be selected using the letter specifiers shown in Table 5-14. Appendix C explains the HLS specifier system in more detail.

If the graphics processor does not understand a specifier, perhaps because it was incorrectly formatted, the output map involved is set to a default light grey: H L50 S0. There is a set of default values for the output map that can be used at power-up. The default values can be described by the command shown in Table 5-15.

The VT125 displays color and brightness by displaying one of four preset values for each pixel on the screen. The VT125 can display each pixel on the screen with a different hue, lightness, or saturation. However, it can do this with only four different combinations at one time. That is, any pixel can be different from its neighbors, but there can only be four different pixel colors on the screen at one time.

The VT125 has a pixel memory and an output map. For each pixel, there are two bits of information. These pairs of bits are in two separate but closely connected planes of addressable locations. (See Figure 5-21 in Writing Controls.) The pairs of bits represent the four numbers 0, 1, 2, and 3 when their binary values are decoded. (The Foreground Planes command has a more detailed discussion of this subject.)

Each of the four numbers is the address of one of four output map locations. Each output map location holds a description of one intensity for the monochrome display in the terminal, and one color for the external color monitor. When the pixel memory is being displayed, each pixel bit pair indicates the output map location that holds the pixel's appearance on the display screen.

Each of the four output map locations holds one of four levels of intensity for the monochrome display: dark, dark grey, light grey, and white, and one of 64 different values of lightness, hue,

and saturation for the color monitor. The information in each of the four output maps can be set using the mapping command with any of the three kinds of specifiers: numbers, letters, or HLS. Table 5-14 (above) lists the specifications for the colors available by integer or RGB letter code in the VT125. Many more colors can be defined with HLS. Figure 5-29 shows the default values stored in the output maps for the internal monochrome and external color monitors.

Specifying anything with A changes a color, specifying anything without A changes only the monochrome map. Figure 5-30 shows sample definitions and the resulting maps.

### Screen Scale

Format: S(S<scale>) or S(S(X<scale>Y<scale>))

This command takes the contents of the graphic memory and changes the portion of the memory that appears on the screen at any one time. If <scale> is a number, for example S(S2), use that number as the scaling value for both the X and Y dimensions. To scale differently in X and Y, put X<number> and Y<number> in parentheses at <scale>, for example S(S(X2)). Legal values in the VT125 are 1 for usual size and 2 for double size. Values less than 1 are understood as 1 and values greater than 2 are understood as 2. Dimensions not specified do not change. When the image is enlarged, the upper left hand corner of the image stays in the same place, so you must offset the display with the Scrolling command to see the other areas of the display. See Hard Copy for the effects of scaling on that command.

### Screen Time Delay

Format: S(T<ticks>)

The time delay option causes ReGIS to delay the processing of the next command for the specified amount of time. Ticks is either 60ths or 50ths of seconds, depending on the Power SET-UP feature setting. The largest possible number is 255, which is approximately 4 or 5 seconds.

Table 5-16 is a summary of the Screen Controls.

MONO		COLOR	
3	WHITE	3	GREEN
2	LIGHT GREY	2	RED
1	DIM GREY	1	BLUE
0	DARK	0	DARK

MA-9461

**Figure 5-29 Default Output Map**

S(M1(AW)) =			
MONO		COLOR	
1	(NO CHANGE)	1	WHITE

S(M2 (L50) (A HO L50 S100)) =			
MONO		COLOR	
2	LIGHT GREY	2	BLUE

S(M3 (L100)) =			
MONO		COLOR	
3	WHITE	3	(NO CHANGE)

MA-9462

**Figure 5-30 Sample Output Map Definitions**



Table 5-16 Screen Controls Summary

S { <pixel vector>	}	Scroll
{ [<position>]	}	
{ (A [<position>] [<position>])	}	Display addressing
{ (E)	}	Erase screen
{ (H [<position>] [<position>])	}	Hard Copy (corner positions optional)
{ (H (P[<position>]))	}	Set Hard Copy Offset
{ (I 0 or (D) )	}	Background
{ 1 (R) )	}	Intensity:
{ 2 (G) )	}	Dark or Dark
{ 3 (B) )	}	Dim grey Red
{ (C) )	}	Light grey Green
{ (Y) )	}	White Blue
{ (M) )	}	Cyan
{ (W) )	}	Yellow
	}	Magenta
	}	White
or	}	
{ (I (H <hue angle>	}	
{ L <lightness percent>	}	
{ S <saturation percent>))	}	
{ S(M<n> (<mono HLS>) (A<color HLS>))	}	Output Mapping
{ (S <scale>)	}	
{ (S (X<scale>Y<scale>))	}	
{ (T <ticks>)	}	Time Delay

**MACROGRAPHS**

Macrographs are a character string substitution utility provided in ReGIS. Strings are command strings or any other string of characters that are stored in the VT125 memory and then substituted in another command string. Generally, a macrograph is a part of or a complete ReGIS command string that is used often. ReGIS inserts the contents of the macrograph in the command string at the position in the command string where the macrograph is invoked.

The twenty-six letters of the alphabet are the keyletters for defining and invoking macrographs, so 26 macrographs can be defined. Each macrograph can be as long or as short as needed. There are at least 5000 characters of storage available in the VT125 memory for all macrographs.

A macrograph can invoke another macrograph but not itself, and you cannot define a macrograph inside a macrograph (the inner terminator terminates the outer definition) or in a quoted string (the definition or invocation characters become part of the text in a quoted string).

### Clear All Macrographs

Format: @.

This is the same as defining all 26 macrographs as null or empty. If this command is inside a macrograph, the macrograph is completed and then all macrographs are cleared.

### Macrograph Definition

Format: @:keyletter character\_string @;

@: (commercial at-sign and colon) Starts the macrograph definition.

#### keyletter

Defines one of the 26 letters of the alphabet to be the name of the macrograph. ReGIS ignores the case of the letter. If a macrograph with the same keyletter was previously defined, it is cleared before the new definition is saved. A null definition (no characters in the character string) is legal and clears any macrograph with that keyletter.

#### character\_string

Specifies the characters that are saved as the macrograph. All characters in character\_string are saved including all control characters. The macrograph definition start and end characters are not included with the saved characters. character\_string has no fixed maximum length, but the number of characters saved in all macrographs should be less than 5000.

@; (commercial at-sign and semicolon)

Ends the macrograph definition and returns ReGIS to the command level it had before invoking the macrograph. The semicolon does not synchronize the command level the way it does at any other place in the command string. Do not put a control character between these two characters.

**Table 5-17 Macrograph Command Summary**

---

@ { .	}	Clear all macrographs
{ :keyletter character_string @;	}	Define macrograph
{ keyletter	}	Invoke macrograph

---

### Macrograph Invocation

Format: @ keyletter

The @ sign and one of the 26 keyletters invokes the macrograph with that name and inserts the character string in the ReGIS command string in place of the @ and keyletter. A macrograph can not be used to supply a keyletter for an @ sign: @@ is illegal. Invoking an empty macrograph is not an error.

Table 5-17 is a summary of the Macrograph commands.

### CHARACTER CELL CONTROLS

The VT125 graphics processor can write text with up to four character sets at one time. Each character set has 95 displayable characters. One character set is always ASCII but the other three can be loaded into the graphics processor's character memory over the communications line.

### Select Character Set for Loading

Format: L(A<integer>)

Select one of three loadable character set memories in the graphics processor for loading. Set 0 is the ASCII character set in the VT125 graphics processor and can not be changed. Sets 1, 2, and 3 can be loaded according to the instructions in Load Character Cell below. The Select command can include a name as in Associate Name below.

The Load command selects a character set for loading, but the actual loading process does not have to follow immediately. Other commands can be performed without changing the selection. In particular, the Text command selects a character set for writing. This Text selection is not the same as the Load selection and does not change the character set selected for loading.

## Associate Name with Current Character Set

Format: L(A"<name>")

This optional command gives a name, which may be up to ten characters long, to the character set currently selected for loading. This name is used for reporting the current character set (see Reports). Both <name> and <integer> (above) may be specified in the same option, but if <name> is specified first, it will be associated with the currently selected set, not necessarily the one specified by <integer>.

## Load Character Cell

Format: L"<ascii char>" <hex pair>,...,<hex pair>;

A character set is 95 cells, with each cell identified by one ASCII printing character in <ascii char> enclosed in double (") or single (') quotes. However, if more than one character is in <ascii char>, only the first character is used and the rest of the characters are ignored.

Each character cell is ten pixels high and eight pixels wide. It is defined by the locations of bits in a series of ten eight-bit bytes that are transmitted as hexadecimal digit pairs separated by commas. You can load other character cells in the set in the same L command by putting the quoted character immediately after the last <hex pair> of the previous character cell. A semicolon terminates the complete Load command. Figure 5-31 shows a sample cell and its construction.

l's represent light (foreground) pixels in usual (non-reversed) writing. The default width for displayed characters using the S<integer> Text command is 9 pixels. The ninth pixel is copied from the first pixel. If you want a dark space between characters, you must either use only the right seven bits in each row (like the permanent ASCII character set), or use the explicit text size and spacing commands.

Cells are always loaded one row at a time using hexadecimal ascii digits for the character specifiers. A cell is specified from the top down, with the most significant bits in the left digit of the specifier. If more than two digits are given for a single line of the character specifier, the digits on the left are ignored. If only a single digit is specified, it fills the low order portion of the character map line specifier, setting the

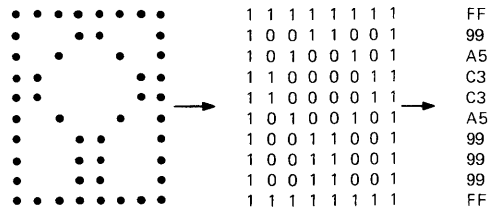

FORMAT: L"a"FF,99,A5,C3,C3,A5,99,99,FF;

MA-9470

Figure 5-31 Sample Character Cells

**Table 5-18 Character Set Definition Format**

---

```
L( A<integer> "<name>") "ascii character"  
  <hex digit>,<hex digit>,...,<hex digit> "ascii  
  character" <hex digit>,...,<hex digit>;
```

---

**Table 5-19 Character Cell Control Summary**

---

L { (A<integer>)	} Select for loading
{	}
{ (A"<name>")	} Give name to set
{	}
{ "<ascii char>" <hex pair>,...,<hex pair>;	} Load cell

---

high order part to zero. If less than ten specifier lines are given, the unspecified portion of the cell is cleared to zero.

Table 5-18 shows the format for a complete character set definition.

Table 5-19 is a summary of the Character Cell controls.

#### REPORTS

The report command causes the graphics processor to send information through the requesting channel. There are three types of reports.

If multiple reports are requested in a single report command or report command option, each separate report requested is sent as if it was the only report requested. Every report sent is ended with a carriage return.

In a terminal to host environment, take care that data reported are not echoed back to the terminal in a way that could cause errors. For example, a cursor position echoed to the terminal could cause either an unwanted vector or curve element, or an unmatched point specifier. A macrograph report that is very long (more than 40 - 50 characters) and is echoed back to the terminal may cause the terminal to hang in a deadlock situation: The terminal refuses (using XOFF) to accept characters echoed until the report is complete. If the host cannot accept the remainder of the report without echoing it, then the deadlock occurs.

#### Report Character Set Selected for Loading

Format: R(L)

The character set name is reported back in the same form as the option specifier that defined it, for example, (A"Greek").

## Report Contents of a Macrograph

Format: R(M(<keyletter>))

The macrograph with name <keyletter> is reported back headed by a macrograph report indicator "@=<keyletter>" and followed by a macrograph terminator "@;" followed by a carriage return. Any control characters that were saved as part of the macrograph are also reported back. If there is no macrograph defined for the keyletter, a null macrograph is reported back (no characters), enclosed in the indicator and terminator. Include more keyletters in the inner parenthesis for more reports. The macrograph report indicator format is ignored if echoed back to the terminal.

## Report Use of Macrograph Storage

Format: R(M(=))

With an equal sign "=" in the command, the report lists the status of macrograph storage in the form:

"<free>,<total>"

where <free> is the number of characters still available for macrograph storage and <total> is the total number of characters of macrograph storage provided in the graphics processor memory. Storage in use may be calculated by subtracting <free> from <total>. The report is ended with a carriage return.

## Report Cursor Position

Format: R(P)

Report the current cursor position in user coordinates as set by Define Display Addressing.

The cursor position is reported as a pair of unsigned numbers, X-value first, enclosed in square brackets.

Table 5-20 is a summary of the Report command.

Table 5-20 Report Command Summary

---

R { (L)	}	Set selected for loading
{	}	
{ (M(<keyletter>)	}	Contents of macrograph
{	}	
{ (M(=)	}	Use of storage
{	}	
{ "<free>,<total>"	}	Reply to Use
{	}	
{ (P)	}	Cursor position

---



## 6.1 INTRODUCTION

The VT105 function set is described in this chapter. It is the same as the VT105 as described in the VT105 User Guide with the following exceptions.

1. The control sequence to enter VT105 mode is not ESC 1, but ESC P t (DCS format). The sequence to exit VT105 mode is not ESC 2, but ESC \ (ST).
2. Only one VT105 emulator can exist in a VT125. Accesses to a second waveform generator board (an optional configuration in the VT105) through command characters P, Q, R, S, T, X, Y, Z [, and \ are ignored.
3. The relative positions of the graphics and text display fields are not exactly the same as in the VT105. There are always at least 6 VT100 character positions to the left of the left graphics margin, and the width of the graphics field with respect to the 80 character VT100 text field may be off by one or two characters.
4. The resolution of the VT105 is mapped into the VT125 display using non-uniform dot spacing. Therefore, there may be some small scale differences visible in some graph presentations.
5. The VT105 interactive graphics test does not exist in the VT125 emulation. The hardware is tested by the VT125 tests.
6. Some actions performed by dedicated hardware in the VT105 (blank, reset, and shade, for example) will take longer to execute in the VT125, and may cause a slight difference in performance between the machines.

NOTE: The state of the VT125 cannot be guaranteed if you switch between protocols. For example, while it may be possible to use ReGIS to add to a VT105 presentation, you cannot be sure that either protocol will be where you left it when you switch between them. This is different from switching between ReGIS and text mode, where ReGIS stays in the same state until you return.

This chapter describes how to:

- Select the graph drawing mode
- Establish the graph area
- Establish desired display
- Load graph data
- Generate shade lines, cursors, and grid
- Enter strip chart data

## 6.2 ENTERING THE GRAPH DRAWING MODE

ESC P t (033 120 164) switches the terminal to VT105 graph drawing mode. The terminal will remain in this mode until ESC \ (033 134) is received.

## 6.3 DEFINITIONS AND LIMITATIONS

**GRAPH:** A graph is a series of points representing the variation in value of two variables: X and Y. For each horizontal value(x), there can be only one Y value; example, a sine wave.

**GRAPH MARKER:** A graph marker is a short vertical line that may be programmed to mark any point of the graph. Each marker represents a specific value of X and appears at intervals of  $Y = 240/16$ . As many as 512 markers can be placed on each graph or histogram for a total of 1024 markers. See Figure 6-1.

**HISTOGRAM:**  
(SHADED GRAPH) A histogram in the VT105 is a graphic display that has the area between the graph line and the bottom of the graph drawing field intensified. Two histograms can overlap and still be discernible. A bar graph is an example of a histogram, as shown in Figure 6-2.

**SHADE LINE:**  
(BASELINE) A shade line (baseline) is the line referenced for shading a graph. One shade line can be displayed for each of the two graphs. If no shade line is established, the graph can be shaded to the bottom of the graph drawing area. (See Histogram.)

**HORIZONTAL LINES/  
VERTICAL LINES:** Horizontal lines and/or vertical lines may be displayed in the graph area to represent set values of X or Y. As many as 512 vertical or 240 horizontal lines may be individually displayed on the screen. For example, a grid is displayed using specific values for horizontal and vertical lines, as shown in Figure 6-3.

**STRIP CAHRT:** A strip chart is a graph or histogram that permits new data to be added to its right side

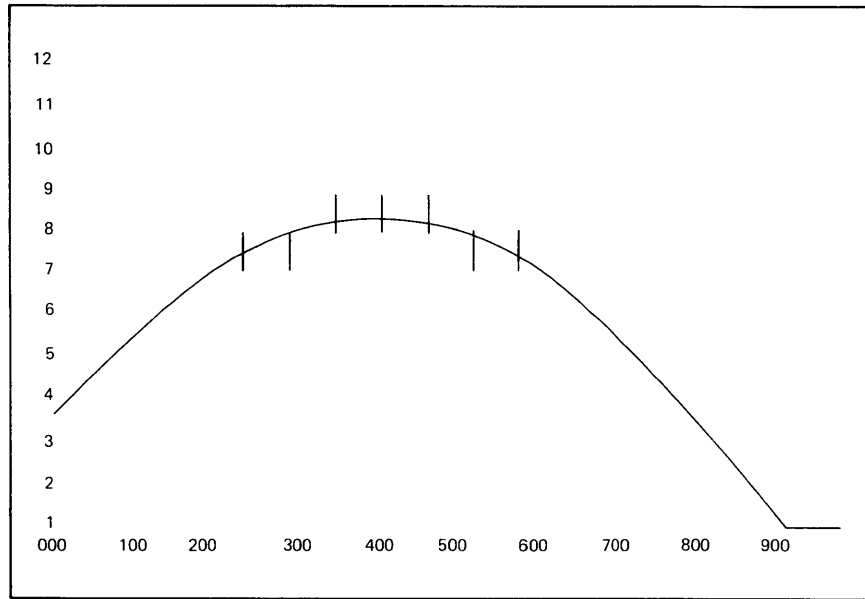

MR-2572  
MA-9458

Figure 6-1 Graph with Graph Markers

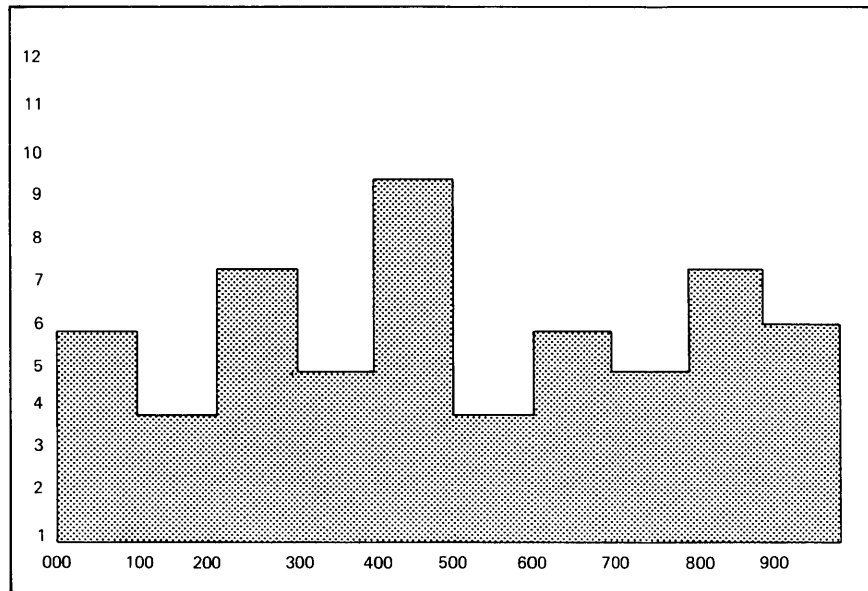

MR-2573  
MA-9459

Figure 6-2 Histogram Display (Shaded Graph)

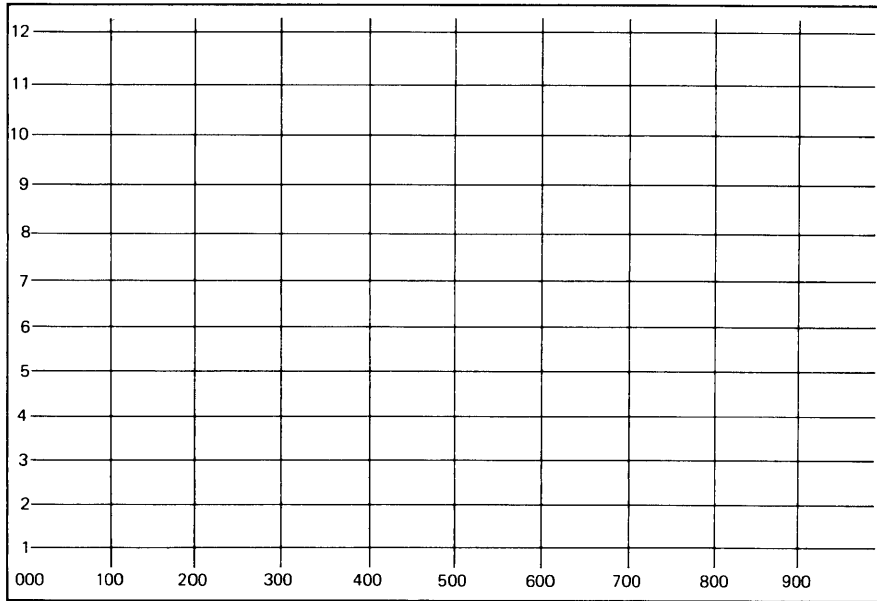

MR 2574  
MA 9438

Figure 6-3 Example of a Grid Display

while shifting previous data to the left, as in Figure 6-4. Vertical and horizontal lines, if present, move from right to left as the strip chart moves, and wrap around the screen as they leave the left edge.

**DUAL STRIP CHART:** Dual strip chart is a feature that allows both Graph 0 and Graph 1 to pass across the screen.

**RECTANGULAR GRAPH DRAWING FIELD:** The rectangular graph drawing field is one of two aspect ratios selectable within the VT105. It has a 20 X 10.9 cm (8 X 4-3/8 in) graph drawing field compatible with previous DIGITAL graph drawing terminals (e.g., VT55). See Figure 6-5.

**SQUARE GRAPH DRAWING FIELD:** The square graph drawing field is a selectable aspect ratio with a 16.5 X 11.5 cm (6.5 X 4.6 in) graph drawing field. It compresses the X-axis length and provides a greater area outside the field for alphanumeric labels, grid identifiers, or notes. See Figure 6-6.

**GRAPH RESOLUTION:** Up to 512 horizontal and 230 vertical points may be displayed per graph in the rectangular graph drawing field; 512 X 240 points, in the square graph drawing field.

#### 6.4 SELECTING THE GRAPH DRAWING FIELD

The VT105 has two selectable graph drawing fields or formats. Both formats display up to two 512-point graphs having single valued functions of X. Either or both graphs can be displayed as a histogram or a strip chart. Graphs and histograms can overlap and still be discernible, allowing the use of the entire field for both graphs, both histograms, or a graph and a histogram displayed together. Both formats display individually programmable horizontal and vertical lines over the entire graph field allowing a grid to represent any desired value. Graph markers can be displayed in either format. Table 6-1 compares the formats and how each is selected.

**Example:**

Character Sequence	Octal Code Sequence	Field
I space!	111 040 041	Enable square format
I space space	111 040 040	Enable rectangular format

#### 6.5 SELECTING DESIRED DISPLAY

Enabling graphs, histograms, strip charts, and shade lines (baselines) is accomplished by loading control register 0 in the Vt105; enabling graph markers, vertical lines, and horizontal lines is accomplished by loading control register 1. The registers are loaded by sending a two or three character sequence from the

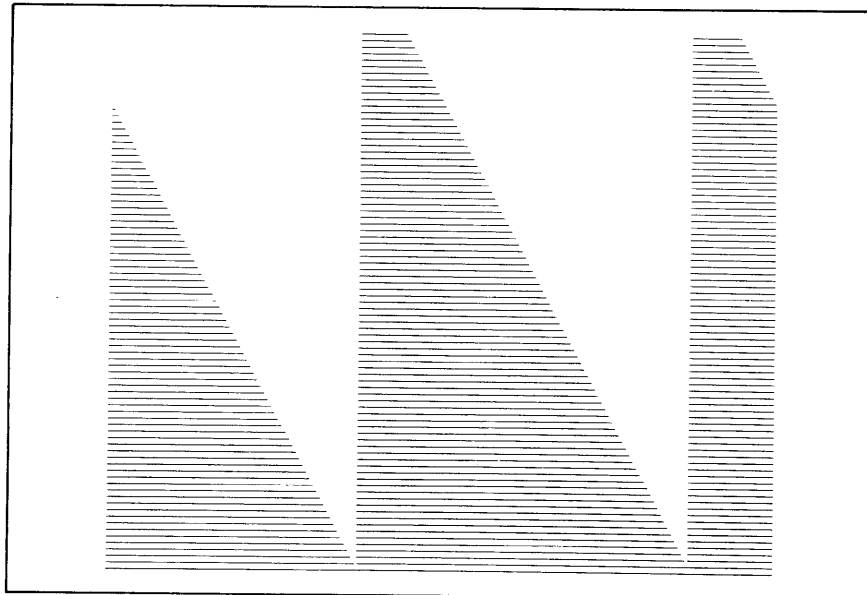

MR-3515  
MA-9453

Figure 6-4 Strip Chart Display  
(Moves From Right to Left)

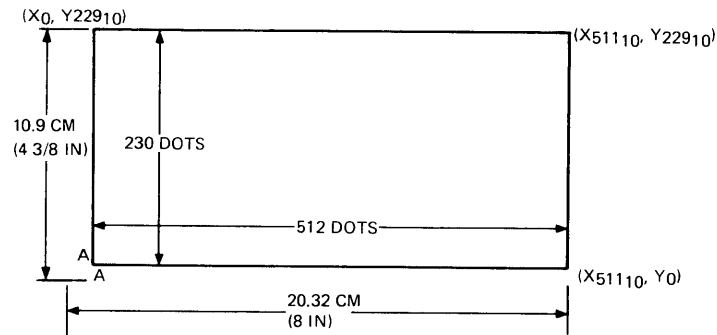

MR-1132  
MA-9456

Figure 6-5 Rectangular Graph Drawing  
Field

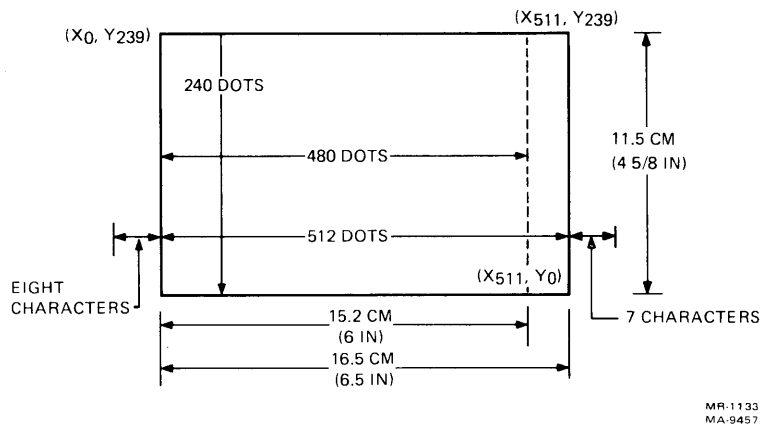

Figure 6-6 Square Graph Drawing Field

Table 6-1 Comparison of Graph Drawing Formats

Feature	Rectangular Format	Square Format
Graph Field (maximum)	20 X 10.9 cm* (8 X 4.3 in)	16.5 X 11.56 cm* (6.5 X 4.625 in)
Graph Resolution (maximum)	512 X 230 points	512 X 240 points
Features		
Graphs	2	2
Shaded Graphs	2	2
Movable Shade lines	1 per graph	1 per graph
Strip Charts	2	2
Vertical Lines	512	512
Horizontal Lines	230	240
Graph Markers	512 per graph	512 per graph
Space provided in left margin for:	1 character (column 1)	8 characters (columns 1--8)
Character lines below graph field:	1 line (line 24)	none
Selected on Initialize	Yes	No
Program selectable by:	I space space	I space!
Display using previous DECgraphic software (i.e., VT55)	Display unchanged	Both height and width are changed
<u>NOTE: These dimensions come from the VT105 specification and are slightly different in the VT125 emulation. Use them for comparison of the formats only.</u>		

keyboard or host computer. The number of characters depends on the type of graph or shade line (baseline) desired. The control bits are encoded as 7-bit ASCII characters that are sent to the terminal.

#### 6.5.1 Loading Control Register 0

To determine the required bits to set in register 0, refer to Table 6-2. A seven digit binary code transmits the desired display. The bits are set as desired, for example: Bit 2 is set to enable Graph 1: bit 0 is set to enable the display. The binary code created is 0100101 (045<sub>8</sub>). For examples of loading register 0, see Table 6-3 and Table 6-4.



Table 6-2 Load Enable Register 0 Command

Rectangular or  
Square Format

1st character: A (101<sub>8</sub>)

2nd character: variable (See below)

3rd character: variable (See below)

Explanation:

The second character is formed by setting bits where the bits have the following functions:

2nd Character (Register 0)

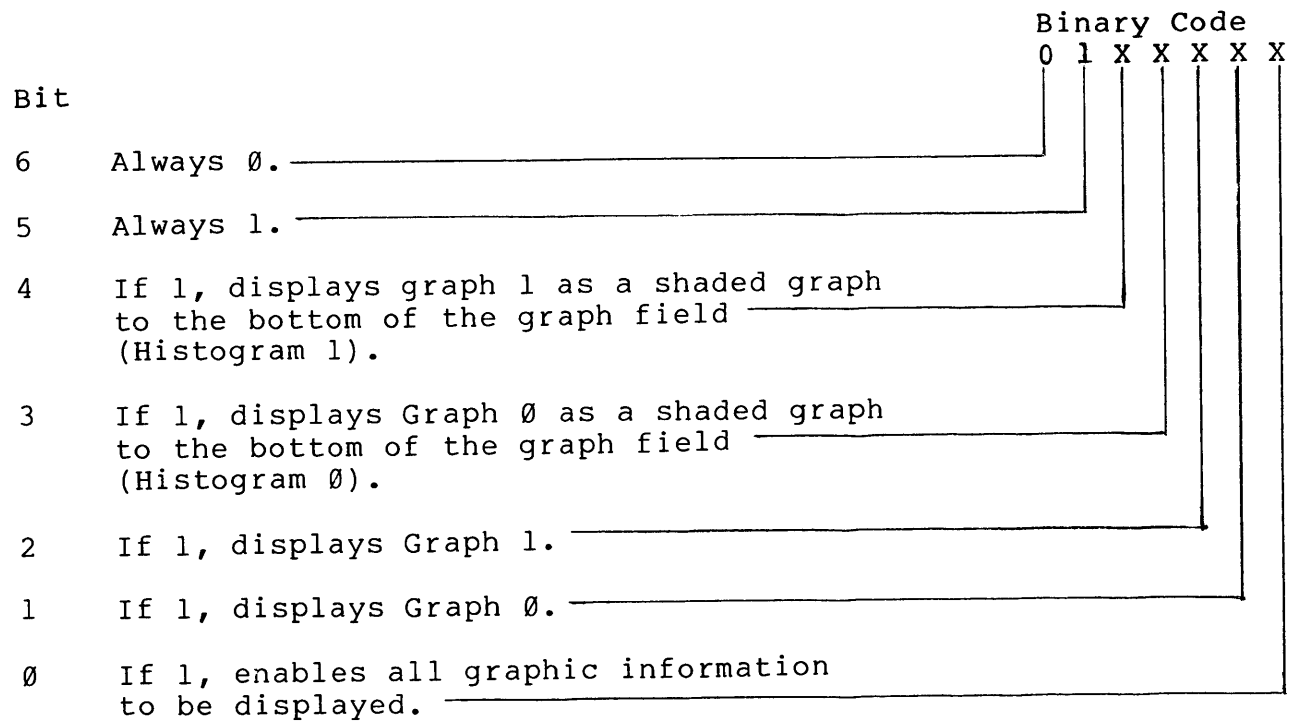

NOTES:

1. Enabling graph 0 and histogram 0 (or graph 1 and histogram 1) at the same time intensifies the graph envelope.

2. Enabling Shade Line 0 (or Shade Line 1) automatically shades Graph 0 (or Graph 1); Histogram 0 (bit 3) and Histogram 1 (bit 4) do not need to be enabled when shade lines are used.

Table 6-2 Load Enable Register 0 Command (Cont)

3rd Character (Register 0)

Bit	Binary Code
	0 1 X X X X X
6	Always 0.
5	Always 1.
4	If 1, allows Graph 0 and 1 data to be shifted from right to left (dual strip chart feature).
3	If 1, allows Graph 0 or 1 data to be shifted from right to left (single strip chart enabled).
2	If 1, displays Graph 1 as a shaded graph, referenced to Shade Line 1.
1	If 1, displays Graph 0 referenced to Shade Line 0.
0	If 0, allows Shade Line 0 data to be loaded by the second word of the @ instruction: if 1, allows Shade Line 1 data to be loaded by the second word of the @ instruction.

NOTE: Bit 3 enables the single strip chart feature; either Graph 0 or Graph 1 data, but not both, can be incremented from right to left.

Bit 4 enables the dual strip chart feature. With Graph 0 enabled, Graph 0 data is entered, but the data does not shift at this time. Graph 1 is enabled and Graph 1 data is entered, then both Graph 0 and Graph 1 will shift their data one increment to the left.

Table 6-3 Examples of Selecting Graphs or Histogram

Function Enabled	Character Sequence*	Octal Code Sequence		Binary Code of 2nd Character	Decimal Value
Graph 0	A#	101	043	0100011	35
Graph 1	A%	101	045	0100101	37
Graphs 0 and 1	A'	101	047	0100111	39
Histogram 0	A)	101	051	0101001	41
Histogram 1	A1	101	061	0110001	49
Histograms 0 and 1	A9	101	071	0111001	57
Graph 0 and Histogram 1	A3	101	063	0110011	51
Graph 1 and Histogram 0	A-	101	055	0101101	45
Disable graphs and histograms	A space	101	040	0100000	32

\* A third character is used to enable (or disable) shaded graphs (referenced to a shade line) and to enable strip charts. See Table 6-4.

Table 6-4 Examples of Selecting Shaded Graphs with Shade Lines (Baselines) and Strip Charts

Function Enabled	Third Character	Octal Code	Binary Code	Decimal Value
Load Shade Line 0*	"	042	0100010	34
Load Shade Line 1*	%	045	0100101	37
Enable Shaded Graphs with Shade Line 0 and 1	&	046	0100110	38
Enable single strip chart	(	050	0101000	40
Enable strip chart with shaded Graph 0 and Shade Line 0	)	052	0101010	42
Dual strip chart	0	060	0110000	48
Dual strip chart with shaded graphs and shade lines	6	066	0110110	54

\* Loading or moving the shade line (base line) in the VT105 does not affect Graph 0 or Graph 1 data. See Paragraph 6.7 for loading shade line position.

Table 6-5 Graph Drawing Characters

Character	Octal Code	Binary Code		Decimal Value
SPACE	040	0100	000	32
!	041	0100	001	33
"	042	0100	010	34
#	043	0100	011	35
\$	044	0100	100	36
%	045	0100	101	37
&	046	0100	110	38
' (apostrophe)	047	0100	111	39
(	050	0101	000	40
)	051	0101	001	41
*	052	0101	010	42
+	053	0101	011	43
' (comma)	054	0101	100	44
- (minus)	055	0101	101	45
	056	0101	110	46
/	057	0101	111	47
0	060	0110	000	48
1	061	0110	001	49
2	062	0110	010	50
3	063	0110	011	51
4	064	0110	100	52
5	065	0110	101	53
6	066	0110	110	54
7	067	0110	111	55
8	070	0111	000	56
9	071	0111	001	57
:	072	0111	010	58
;	073	0111	011	59
<	074	0111	100	60
=	075	0111	101	61
>	076	0111	110	62
?	077	0111	111	63

Table 6-5 can be used to convert the binary codes created for register 0 to the program requirements.

Example:

Function	Octal Code	Character	Code
Enable Graph 1	045	%	0100101

6.5.2 Enabling Graphs and Histograms (Shaded Graphs)

The second character in a sequence for loading register 0 selects the graph or histogram to be displayed. The letter a (101<sub>8</sub>) allows register 0 to be loaded.

6.5.3 Enabling strip Charts and Shade Lines (Baselines)

The third character in the load register 0 sequence enables shaded graphs and strip charts. Some of the common functions enabled by the third character are listed in Table 6-4.

6.5.4 Loading Control Register 1

the characters required to enable graph markers and grid lines are formed by setting the appropriate bits in the diagrams in Table 6-6, then finding the character for the code created in Table 6-5.

Table 6-6 Load Enable Register 1 Command

1st character: I (111<sub>8</sub>) 73<sub>10</sub>  
 2nd character: variable (see below)  
 3rd character: variable (see below)

2nd Character (Register 1)

		Binary Code						
		0	1	X	X	X	X	X
Bit								
6	The most significant bit is always 0.							
5	Always 1.							
4	If 1, clears the static RAMs containing any vertical lines, horizontal lines, Graph 0, Graph 1, and any graph markers. It does not clear the load enable register -- Register 0 and Register 1.							
3	If 1, allows Graph 1 markers to be displayed.							
2	If 1, allows Graph 0 markers to be displayed.							
1	If 1, allows vertical lines to be displayed.							
0	If 1, allows horizontal lines to be displayed.							

Table 6-6 Load Enable Register 1 Command (Cont)

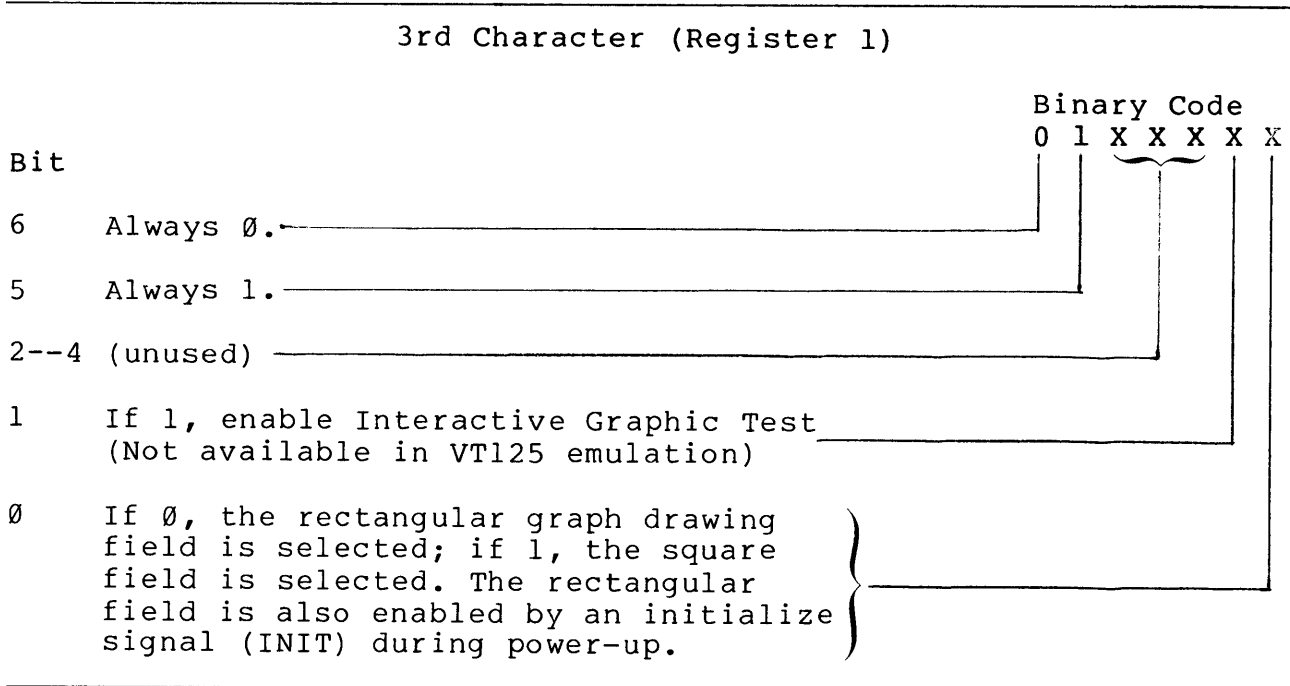

### 6.5.5 Enabling Graph Markers, Vertical Lines, and Horizontal Lines

Turning graph markers and grid lines ON and OFF is accomplished by loading register 1. The character sequence is the same in either graph drawing format, except a third character establishes the desired format. The exclamation mark,  $!(041_8)$ , enables the square format; a SPACE  $(040_8)$  enables the rectangular format. The rectangular format is enabled also on initializing the terminal.

Table 6-7 shows examples of enabling graph markers, horizontal lines, and vertical lines.

### 6.6 FORMING GRAPH DRAWING DATA CHARACTERS

In order to represent a horizontal or vertical address of a point on a  $240 \times 512$  point graph, at least 9 binary bit positions are required.

$$\begin{aligned} \text{Examples: } 239_{10} &= 011101111_2 \\ 511_{10} &= 111111111_2 \end{aligned}$$

Keys typed from the keyboard, or transmitted from the host computer, normally only contain 7 digits (7-bit ASCII characters). Therefore, two keys must be typed, or two codes transmitted, to fully describe an X or a Y value. The first key (character) transmits the lower five bits of the binary data value: the second key transmits the remaining bits, or upper data value.

Table 6-7 Examples of Selecting Graph Markers, Horizontal Lines, and Vertical Lines

NOTE: Remember to bit map all options correctly when sending out a command. Setting a desired feature may reset other features if all options are not considered.

Function Enabled	Character Sequence	Octal 1st	Sequence* 2nd	Binary Code of 2nd Char.	Decimal Value
Clear graph drawing memories	IØ	111	Ø6Ø	Ø11ØØØØ	48
Enable horizontal and vertical lines	I#	111	Ø43	Ø1ØØØ11	35
Enable horizontal lines only	I!	111	Ø41	Ø1ØØØØ1	33
Enable vertical lines only	I"	111	Ø42	Ø1ØØØ1Ø	34
Enable Graph Ø markers	I\$	111	Ø44	Ø1Ø11ØØ	36
Enable Graph 1 markers	I(	111	Ø5Ø	Ø1Ø1ØØØ	4Ø
Enable Graph Ø and 1 markers	I,	111	Ø54	Ø1Ø11ØØ	44
Enable grid and Graph Ø markers	I'	111	Ø47	Ø1ØØ111	39
Enable grid and Graph 1 markers	I+	111	Ø53	Ø1Ø1Ø11	43
Enable grid and Graph Ø and 1 markers	I/	111	Ø57	Ø1Ø1111	47
Disable lines and graph markers	I space	111	Ø4Ø	Ø1ØØØØØ	32

\* A third character is required to establish the square format, to change formats, or to set up the Interactive Graphics Test.

To load coordiantes for the function enabled by register 1, refer to the following paragraphs.

Function	Paragraph
Load graph markers	6.1Ø
Load vertical lines	6.11
Load horizontal lines	6.12

The graph drawing data characters can be standardized to the 32 characters listed in Table 6-8 if bits 5 and 6 of each character are always 1 and 0, respectively, as in the following format:

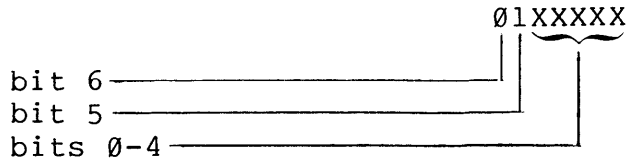

The data value is then transmitted in two parts as in the diagram below:

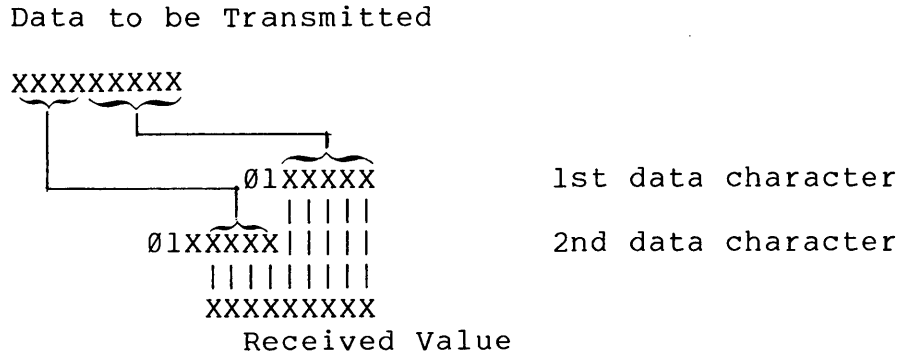

### 6.6.1 Selecting Upper and Lower Data Characters

The value of the lower data ranges from 0 to  $31_{10}$ ; the upper data value increases in increments of 32 decimal units. Together they can describe any value of the graph drawing field. To find the characters or code to transmit a desired location, perform the following.

1. Select the upper data value closest, but not exceeding, the desired value in Table 6-8. This is the second data character which is transmitted last.

Example:

Value To be Transmitted	Nearest Upper Data Value	Second Data Character	Binary Code	Octal Code
$200_{10}$	$192_{10}$	&	$0100110_2$	$046_8$

NOTE: If a horizontal line, vertical line, or graph marker is to be loaded, use values in the lower half of the upper data column; i.e.,  $192_{10}$  is  $066_8$  or the character 6.



Table 6-8 Graph Drawing Data Characters

Decimal Lower data 1st data	Data Value Upper data 2nd data	Binary Code	Octal Code	Data Character
	Load shade line (base- line) and graph data; erase other lines.			
0	0	01000000	040	SPACE
1	32	01000001	041	!
2	64	01000010	042	"
3	96	01000011	043	#
4	128	01001000	044	\$
5	160	01001001	045	%
6	192	01001100	046	&
7	224	01001101	047	' (apostrophe)
8	256	01010000	050	(
9	288	01010001	051	)
10	320	01010010	052	*
11	352	01010011	053	+
12	384	01011000	054	, (comma)
13	416	01011001	055	-(minus)
14	448	01011100	056	.
15	480	01011101	057	/
	Load Horizontal, vertical lines, and markers*			
16	0	01100000	060	0
17	32	01100001	061	1
18	64	01100010	062	2
19	96	01100011	063	3
20	128	01101000	064	4
21	160	01101001	065	5
22	192	01101100	066	6
23	224	01101101	067	7
24	256	01110000	070	8
25	288	01110001	071	9
26	320	01110010	072	:
27	352	01110011	073	;
28	384	01111000	074	<
29	416	01111001	075	=
30	448	01111100	076	>
31	480	01111101	077	?

\* Upper data values below this line are used for loading graph markers and horizontal or vertical lines; they require bit 4=1. To erase these lines, or load shade lines (baselines), graph data or starting X-coordinate, use values above this line.

Table 6-9 Load Data Sequences

Function	Load Character	Character Sequence	Range
Load shade line (baseline)	@	@ 1st data 2nd data	0--239
Load Graph 0 data	B	B 1st data 2nd data	0--239
Load Graph 1 data	J	J 1st data 2nd data	0--239
Load Graph 0 marker	C	C 1st data 2nd data	0--511
Load Graph 1 marker	K	K 1st data 2nd data	0--511
Load horizontal line	D	D 1st data 2nd data	0--239
Load vertical line	L	L 1st data 2nd data	0--511
Load starting X-coordinate	H	H 1st data 2nd data	0--511

- Find the remainder of the value to be transmitted in the lower data value column. This will be the first data character transmitted.

Example:

Remaining Value	Lower Data Value	First Data Character	Binary Code	Octal Code
8	8	(	0101000 <sub>2</sub>	050 <sub>8</sub>

### 6.6.2 Load Data Sequences

The data to be transmitted is initially preceded by a "load character," as described in Table 6-9. In the above example, loading a shade line at line 200<sub>10</sub> is transmitted by @(& or equivalent program. Storing a horizontal line at line 200<sub>10</sub> is transmitted by D(6 or equivalent program.

For multiple data entries, the load character does not need to be repeated. This allows data for a graph to be loaded into memory without repeating the character B or J. Exceptions to this procedure are loading a shade line and loading the starting X-coordinate.

### 6.6.3 Frequent Data Entry Errors

**Largest Data Character Transmitted First** -- The low-order bits of the data value (lower data value in Table 6-8) must be transmitted first; if reversed, the point will typically exceed the range limits of the graph drawing field and not be displayed, or, it may appear near the edge of the field.

Example:

Desired Shade line	Data Transmitted	Characters Should be	Characters Reversed	New Values
40	8 + 32	@(!	@!(	1+256
70	6 + 64	@&"	@"&	2+192

Table 6-10 Loading Shade Line Position

	Previous VT55 Format	New VT105 Format Load Shade Line
1st character:	@ NOP	@ (100 <sub>8</sub> ) 64 <sub>10</sub>
2nd character:	none	01XXXXX
3rd character:	none	01XXXXX

NOTE: Shade Line 0 or Shade Line 1 is loaded depending on which shade line is selected by loading register 0. See paragraph 6.5.3.

Zero Valued Characters Not Transmitted -- When transmitting data with two characters, if the upper data value is equal to the point or line desired, a SPACE (040<sub>8</sub>) (equal to zero) must be the first data character. If missed, the line or point will be much less than desired.

Example:

Shade line Desired	Data Required	Characters Should be	Characters In error	Wrong Value
160	0 + 160	@ SPACE %	@%	5

#### 6.7 LOADING THE SHADE LINE (BASELINE)

A movable shade line can be displayed for both Graph 0 and Graph 1. One shade line can be entered for Graph 0, and one for Graph 1, on any of the 230 (or 240, square format) horizontal lines available. To transmit positions within this range, a load character and two data characters are used, as shown in Table 6-10. Positions can be created by following Paragraph 6.6 for forming graph drawing data characters.

#### 6.8 LOADING GRAPH MEMORIES

The M7071 has two graph memories -- Graph 0 and Graph 1. Each graph may plot up to 512-horizontal points. Each horizontal point may have only one value using up to 230 vertical points with the rectangular format (or 240 vertical points with the square format). The graph will begin entering data at X = 0 (040<sub>8</sub>) unless a starting X-address is specified. (See Paragraph 6.13.)

The data to be entered is initially preceded by the letter B (102<sub>8</sub>) for Graph 0, or J (112<sub>8</sub>) for Graph 1. Each pair of data characters describes a Y-data point.

A Y-value is entered for each value of X, using two data characters, as described in Paragraph 6.6. As the X-address is incremented from 0 to 511, the values of Y can sequentially be loaded into memory. The X-register will automatically increment after each pair of Y-data characters are stored in memory, except

Table 6-11 Loading Graph Data

	Graph 0	Graph 1
1st character:	B (102 <sub>8</sub> )	J (112 <sub>8</sub> )
2nd character:	variable (see below)	variable
3rd character:	variable (see below)	variable

Explanation of Second Character:

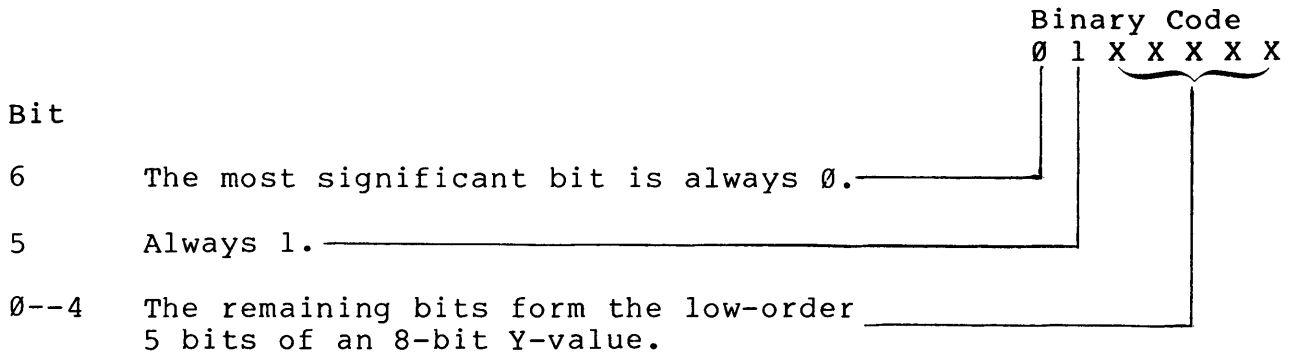

Explanation of Third Character:

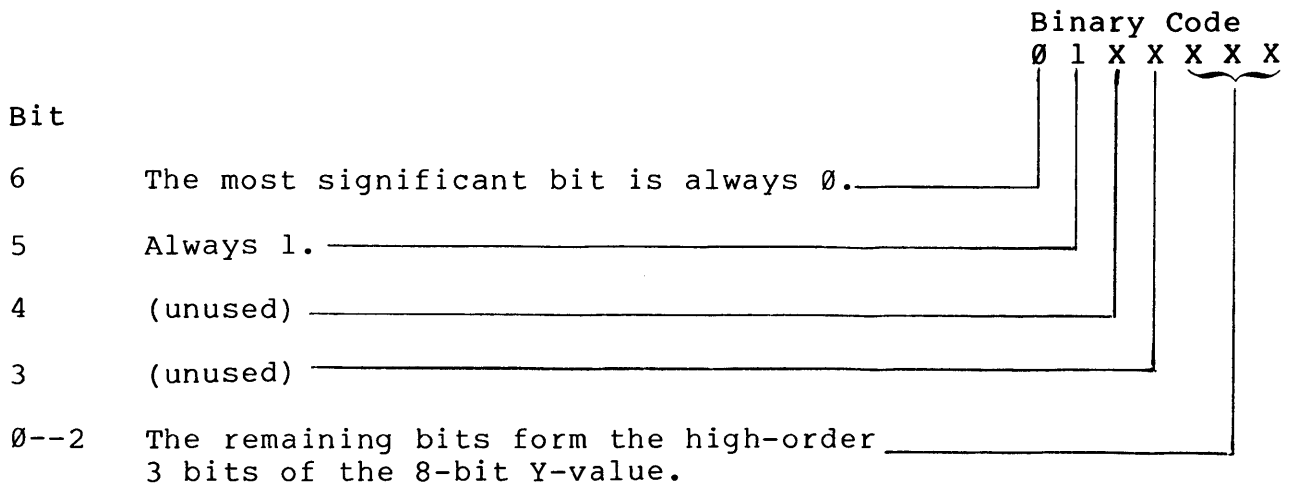

when dual strip charts are enabled. (See paragraph 6.14.) The letters B or J do not need to be repeated for each pair of Y-data characters. Table 6-8 may be used to determine the Y-data characters.

NOTE: For each value of Y, the lower data value must be transmitted first, then the upper data value.

The formation of graph data characters is illustrated in Table 6-11.

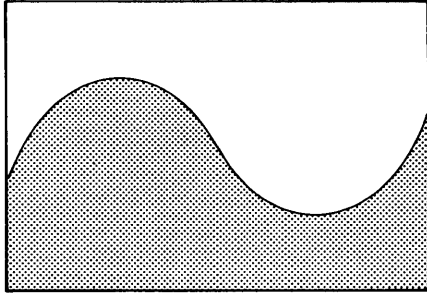

MR-3516  
MA-9454

Figure 6-7 Histogram without Shade Line  
(Baseline) Enabled

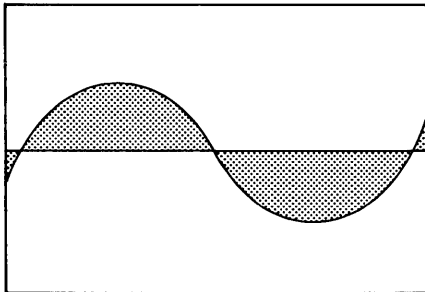

MR-3517  
MA-9455

Figure 6-8 Graph with Shade Line  
(Baseline) Enabled

## 6.9 HISTOGRAM DATA

Data for a histogram (shaded graph) is entered by loading the appropriate graph memory (Paragraph 6.8). Histogram 0 and/or Histogram 1 is enabled by loading register 1 (Paragraph 6.5). Enabling a histogram will shade points between the graph envelope and the bottom of the graph field. Shading occurs from the graph data to graphline 0 (Figure 6-7). With a shade line (baseline) enabled, the graph is shaded above and below this line, as in Figure 6-8.

## 6.10 LOADING GRAPH MARKER MEMORY

A graph marker is a short vertical line which marks the graph line at a desired value of X. A graph marker can be programmed for any point on Graph 0 and on Graph 1. As many as 512 graph markers can be placed on each graph.

Loading graph marker memory is accomplished by sending pairs of data characters following the letter C (103<sub>8</sub>) for Graph 0, or K (113<sub>8</sub>) for Graph 1. Each pair of data characters represents the lower data value and the upper data value of an X-address, as illustrated in Table 6-12. Note that bit 4 of the third character determines whether the graph marker will be loaded or erased.

Example:

Function	Binary Code	Octal Code	Character Sequence
Load graph 0 marker at location 100	1000110	106	C\$3
	0100100	044	
	0110011	063	
Erase graph 0 marker at location 100	1000110	106	C\$#
	0100100	044	
	0100011	043	

Table 6-8 may be used to determine the characters required to load or erase a specific graph marker. Once stored in memory, graph markers are enabled and disabled by loading register 1. (See Paragraph 6.5.4.)

## 6.11 DISPLAYING VERTICAL LINES

Vertical lines may be programmed for any of the 512 points along the X-axis. Vertical lines are loaded following the letter L (114<sub>8</sub>). The second and third characters form an X-data value, as illustrated in Table 6-13. Note that bit 4 of the third character must equal a 1 for the line to be loaded; a 0 in bit 4 will erase that line. Table 6-8 may be used to determine the characters required to load or erase a specific line. Vertical lines are enabled and disabled by loading register 1. (See Paragraph 6.5.4.)

Table 6-12 Load Graph Marker Memory

	Graph 0 Marker	Graph 1 Marker
1st character:	C (103 <sub>8</sub> )	K (113 <sub>8</sub> )
2nd character:	variable	variable
3rd character:	variable	variable

Explanation of Second Character:

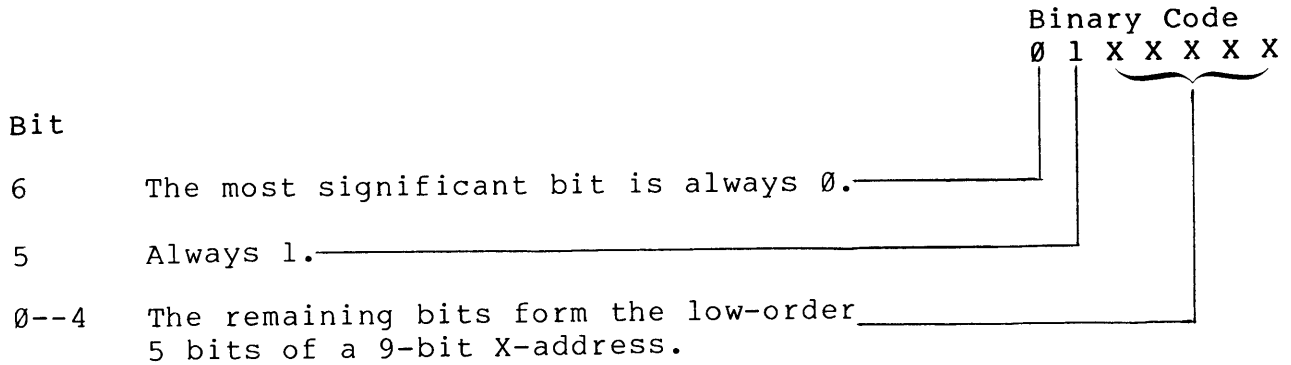

Explanation of Third Character:

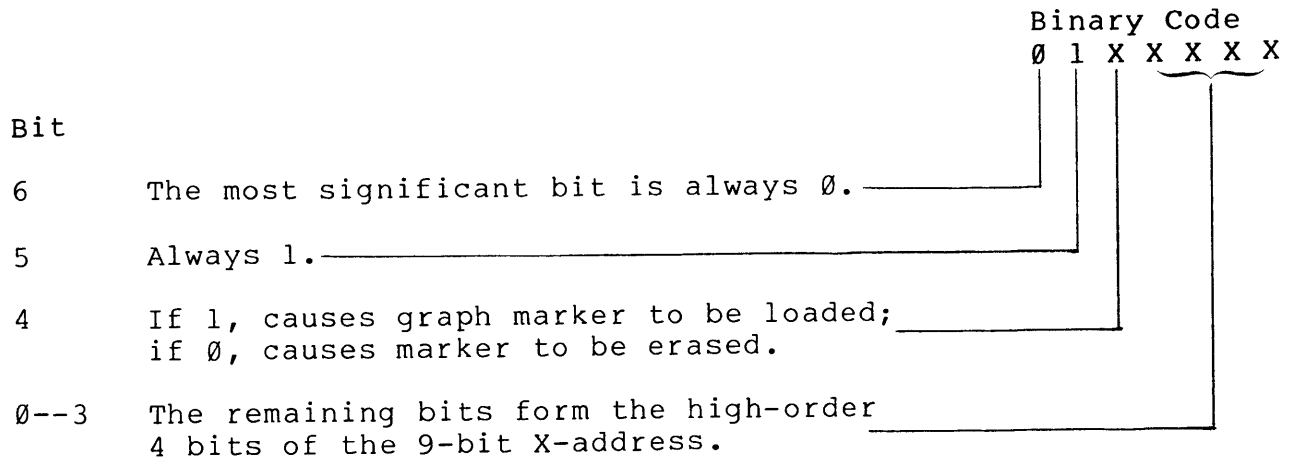
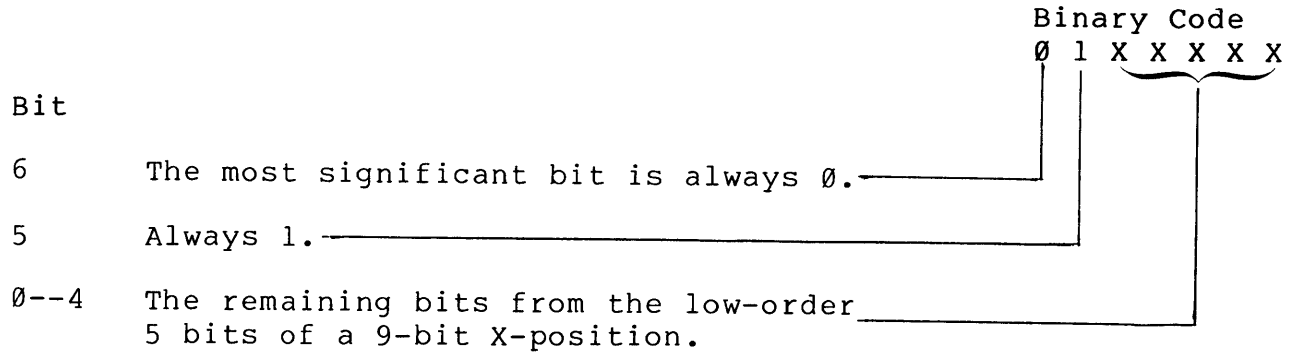

Table 6-13 Load Vertical Line Coordinate

1st character: L (114<sub>8</sub>)  
 2nd character: variable (see below)  
 3rd character: variable (see below)

Explanation of Second Character:



Explanation of Third Character:

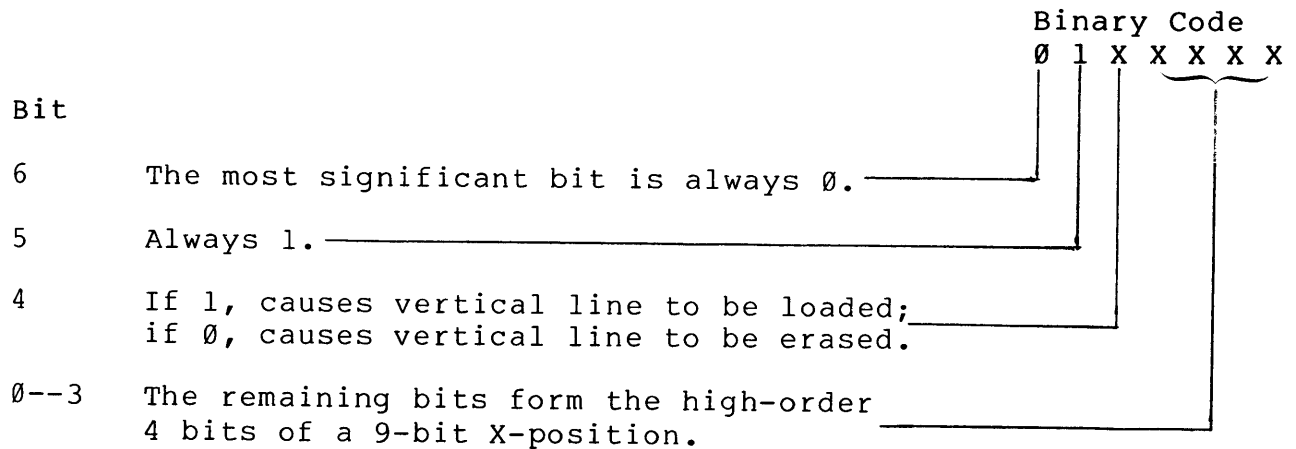

6.12 DISPLAYING HORIZONTAL LINES

A horizontal line is loaded into memory by two data characters following the letter d (104<sub>8</sub>). The second and third characters from a Y-data value, as illustrated in Table 6-14. Up to 230 horizontal lines may be displayed in the rectangular format; 240, in the square format. Note that bit 4 in the third character must equal a 1 to load a horizontal line; bit 4=0 will erase the line. Table 6-8 can be used to determine the characters required to load or erase a specific horizontal line. Horizontal lines are enabled and disabled by loading register 1. (See Paragraph 6.5.4.)



Table 6-14 Load Horizontal Line Coordinates

1st character: D (104<sub>8</sub>)  
 2nd character: variable (see below)  
 3rd character: variable (see below)

Explanation of Second Character:

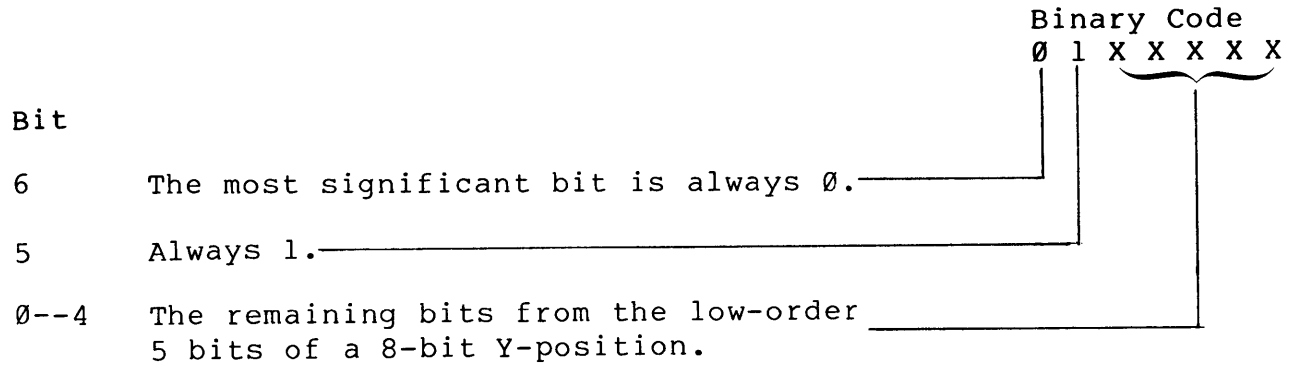

Explanation of Third Character:

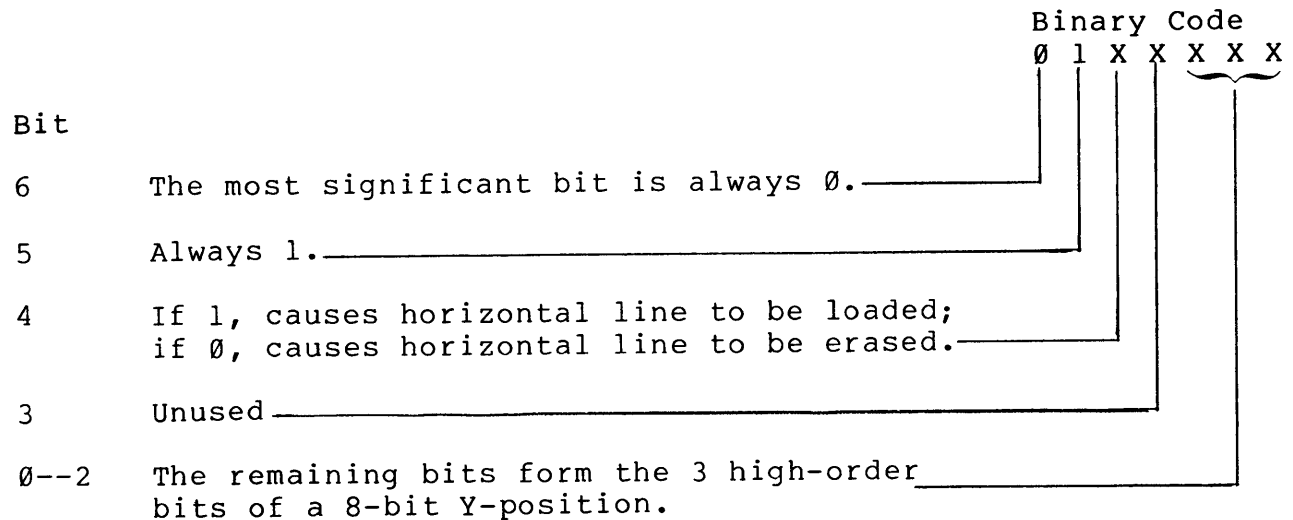

6.13 LOAD THE STARTING X-COORDINATE

A starting X-coordinate may be loaded by two data characters following the letter H (110<sub>8</sub>), as illustrated in Table 6.15. Any value of X, from 0 to 511, may be used. The data characters required for the desired X starting address can be determined from Table 6-8.

NOTE: The lower data value of X must be transmitted first, then the upper data value.

6.14 ENTERING STRIP CHART DATA

**Table 6-15 Load Starting X Coordinate**

1st character: H ( $110_8$ )  
 2nd character: variable (see below)  
 3rd character: variable (see below)

**Explanation of Second Character:**

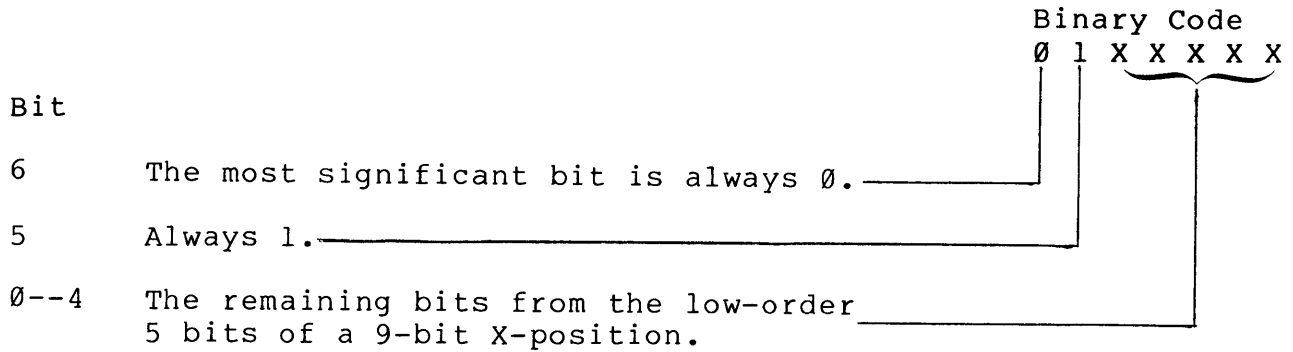

**Explanation of Third Character:**

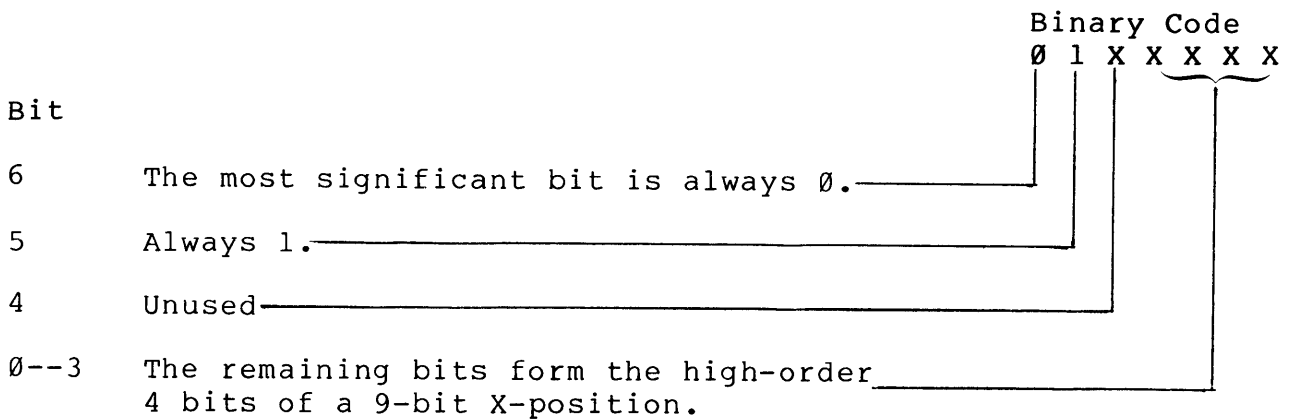

**6.14.1 Single Strip Chart Data**

Data for a single strip chart is entered by loading either Graph 0 or Graph 1 memory.

1. Enable the desired graph and single strip chart feature by loading register 0. (See Table 6-2.)

**Example:**

Enable Graph 0, Single Strip Chart, and Shade Line 0.  
 Enter:

Character Sequence	Octal Sequence	Decimal Sequence
A#*	$101_8\ 043_8\ 052_8$	$65_{10}\ 35_{10}\ 42_{10}$

2. If desirable, load the starting X-coordinate at the right margin. Enter:

H??                      110<sub>8</sub> 077<sub>8</sub> 077<sub>8</sub>                      72<sub>10</sub> 63<sub>10</sub> 63<sub>10</sub>

3. Now, enter data into Graph 0 memory; type B plus any sequence of two data characters. If started at the right margin, this will cause the graph to move from right to left; if not, the graph will fill the screen first, then move data from right to left with each new data word.

B(data)(data)              102<sub>8</sub>(data)(data)              66<sub>10</sub>(data)(data)

#### 6.14.2 Dual Strip Chart Data

To set up the dual strip chart feature:

1. Enable both graphs and the dual strip chart feature; set bit 4 of the 3rd character in register 0. (See Table 6-2.)

Example:

Load Graph 0 and 1, dual strip chart, and Shade Line 0 and 1. Enter:

Character Sequence	Octal Sequence	Decimal Sequence
A '6	101 <sub>8</sub> 047 <sub>8</sub> 066 <sub>8</sub>	65 <sub>10</sub> 39 <sub>10</sub> 54 <sub>10</sub>
H??	110 <sub>8</sub> 077 <sub>8</sub> 077 <sub>8</sub>	72 <sub>10</sub> 63 <sub>10</sub> 63 <sub>10</sub>

3. Enter Graph 0 data; enter a B and two data characters. (The data is entered, but the graph will not move at this time.)

B(data)(data)              102<sub>8</sub>(data)(data)              66<sub>10</sub>(data)(data)

4. Enter Graph 1 data; enter a J plus two data characters. The graph will now display and shift both Graph 0 and Graph 1 data points one increment to the left.

J(data)(data)              112<sub>8</sub>(data)(data)              74<sub>10</sub>(data)(data)

#### NOTES:

1. Load starting X-coordinate, desired graph markers, and vertical lines before enabling either single- or dual-strip chart mode. The exact position of these points may vary once a strip chart is enabled.
2. Any graph markers and vertical lines enabled will wrap around as the strip chart moves.

3. When the strip chart mode is disabled, any displayed graphics shifts. The X-coordinate that moved during strip chart mode returns to its normal location.
4. When in dual-strip chart mode, the last available graph position (X=511) is not displayed. The switching action between Graph 0 and Graph 1 in that position is eliminated from the display.

#### GENERAL

This chapter describes how the VT125 terminal communicates with a computer using the standard EIA interface. Also included are descriptions of the communication features, a definition of the Break signal, a description of the communication of the graphics processor with the rest of the terminal and its options, and methods used to prevent input buffer overflows of the terminal.

NOTE: The 20 mA current loop interface option (VT1XX-AA) is described in Chapter 10 Options.

#### CONNECTING TO THE COMPUTER PORT

The VT125 terminal is connected to a computer directly or through a common carrier facility (telephone line) as shown in Figure 7-1. In both applications, either the Electronic Industry Association (EIA) interface provided with the terminal or the VT1XX-AA 20 mA Current Loop interface option are used. Table 7-1 lists the Computer Port EIA connector signals.

When connecting the terminal to the computer through a telephone line, a modem or acoustic coupler is needed. The modem or acoustic coupler changes the serial characters transmitted between terminal and computer into signals that can be transmitted over the telephone line. Several types of modems can be used with the VT125 terminal. However, the modem used by the terminal must be compatible with the modem used by the computer.

#### CONNECTING TO THE AUXILIARY PORT

The auxiliary port is for connecting a graphics or text printer to the VT125. It is bidirectional so it can also be used for input to the computer. The application program on the computer must use the Media Copy commands (Chapter 4, Communication and Graphic Protocol controls) to use the auxiliary port.

#### SERIAL CHARACTER FORMAT

The VT125 terminal communicates using serial characters. Serial characters are transmitted using a start bit, 7 or 8 data bits, an optional parity bit and one or two stop bits. Figure 7-2 shows an example of the serial character format used by the terminal.

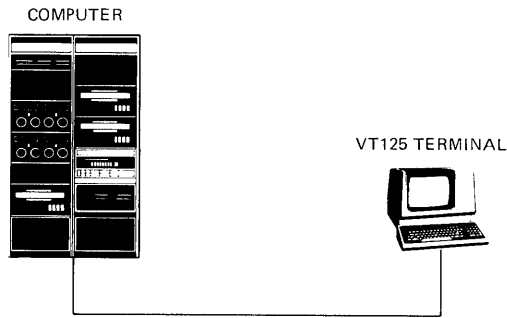
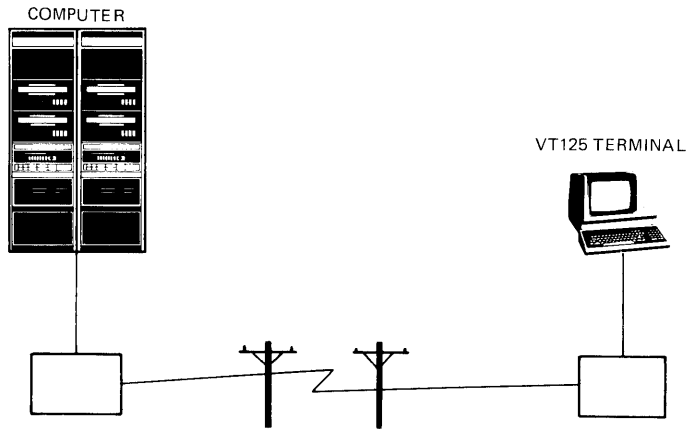

MA-7776-A

Figure 7-1 Connecting to the Computer

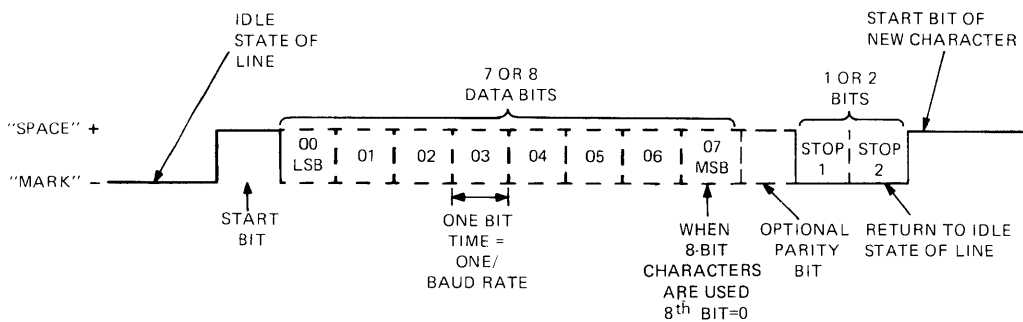

MR-1279  
MA-7815

Figure 7-2 Serial Character Format

**Table 7-1 Computer Port EIA Connector Signals**

Pin	Name	Mnemonic	CCITT/EIA Designation	Description
1	Protective Ground	PGND	101/AA	Connected to the VT125 chassis and to external ground through the third wire of the AC power cord.
2	Transmitted Data	TXD	103/BA	FROM VT125 The VT125 transmits serial characters and Break signals on this circuit. This conductor is in the mark state when no characters or Break signals are being transmitted.
3	Received Data	RXD	104/BB	TO VT125 This conductor receives serial characters from the computer.
4	Request to Send	RTS	105/CA	FROM VT125 This signal is on whenever the terminal is on.
7	Signal Ground	SGND	102/AB	This conductor is the common ground reference potential for all connector signals except protective ground. Also, it is connected to the VT125 chassis.
20	Data Terminal Ready	DTR	108.2/CD	FROM VT125 This signal is on except when the following conditions exist: <ul style="list-style-type: none"> <li>• VT125 is not on</li> <li>• VT125 is LOCAL</li> <li>• During a reset</li> <li>• 3.5 seconds during a Long Break Disconnect.</li> </ul>
23	Speed Select	SPDSEL	111/CH	FROM VT125 Also called Secondary Request to Send, this signal is on whenever the VT125 is on.

The number of data bits per character and parity are selected using the Parity Sense, Parity, and Bits Per Character SET-UP B features. If 8-bit characters are selected, the last data bit is forced to the Space (Ø) condition and the eighth data bit is ignored when receiving characters. The data bits are transmitted with the least significant bit first. (Refer to ANSI X3.15-1976 for details on the serial character format.)

The parity bit is used to detect character transmission errors of both transmitted and received characters. The Parity Sense SET-UP B feature selects the type of parity bit used when transmitting and receiving characters.

The Parity SET-UP B feature determines if the parity of received characters is checked or ignored. If the Parity SET-UP B feature is off, the parity bit is removed from the serial character.

The number of stop bits (1 or 2) in the serial character is determined by the Transmit and Receive Speed SET-UP B features.

#### **BREAK SIGNAL**

A Break signal can be transmitted by the terminal. The Break signal is a transmitted space condition for 0.275 seconds  $\pm 10$  percent. However, the computer response to the Break signal depends on the computer and software used. A Long Break Disconnect is a transmitted space condition for 3.5 seconds  $\pm 10$  percent and then the Data Terminal Ready interface signal is turned off.

NOTE: On some modems, the Long Break Disconnect causes the modem to perform a communication line disconnect.

#### **FULL DUPLEX COMMUNICATION**

The VT125 terminal operates in full duplex communication. Full duplex communication means that the terminal transmits and receives characters at the same time. The VT125 provides some EIA signals as listed in Table 7-1.

#### **ELECTRONIC INDUSTRY ASSOCIATION (EIA) INTERFACE**

The VT125 communication interfaces are DB-25 (EIA RS-232-C type) male connectors mounted on the back of the terminal as shown in Figure 7-3. These connectors meet Electronic Industry Association (EIA) standards RS-232-C and CCITT V.24 and V.28. When connecting to a device which meets EIA standard RS-232-C, the terminal can operate at speeds up to 19200 baud using communication cables up to 15 meters (50 feet) in length. Table 7-1 describes the EIA connector pin signals used by the computer port. Table 7-2 describes the EIA connector pin signals used by the auxiliary port. All connector pins not described are not used by the terminal. Figure 7-3 shows the connector pin arrangement.



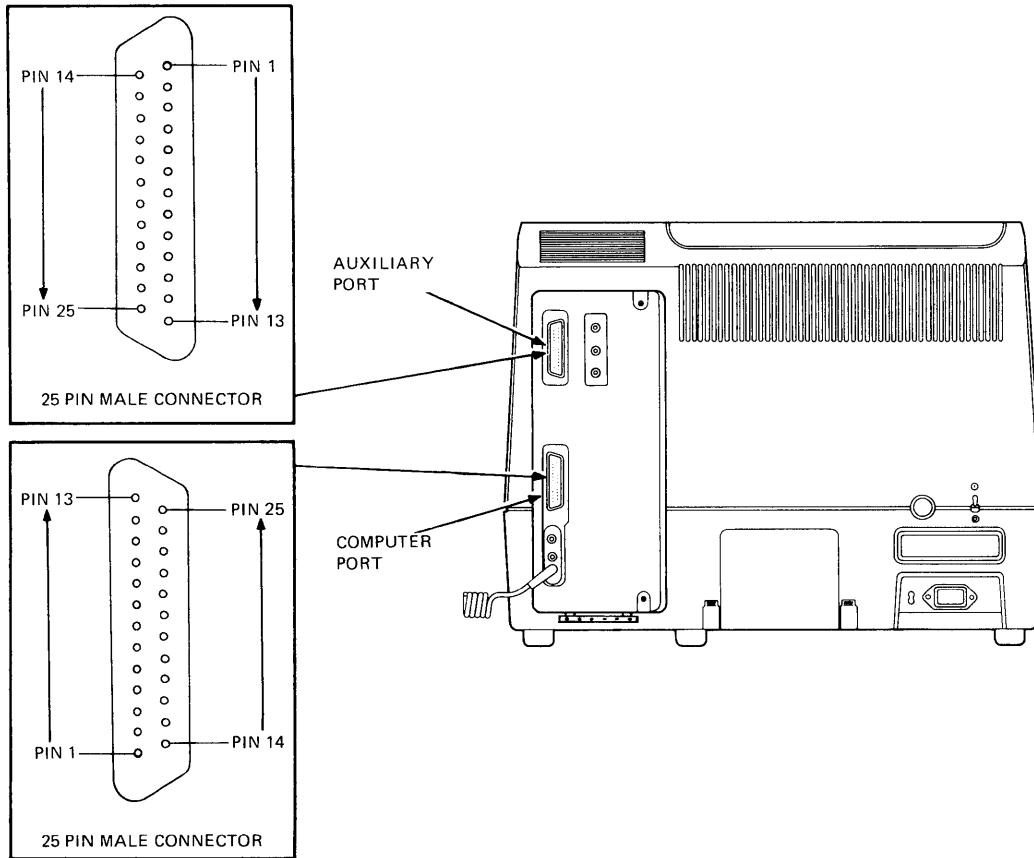

MA-9471

**Figure 7-3 EIA Connectors and Pin Locations**

**Table 7-2 Auxiliary Port EIA Connector Signals**

Pin	Name	Mnemonic	CCITT/EIA Designation	Description
1	Protective Ground	PGND	101/AA	Connected to the VT125 chassis and to external ground through the third wire of the AC power cord.
2	Transmitted Data	TXD	103/BA	FROM VT125 The VT125 transmits serial characters and Break signals on this circuit. This conductor is in the mark state when no characters or Break signals are being transmitted.
3	Received Data	RXD	104/BB	TO VT125 This conductor receives serial characters from the auxiliary port.
6	Data Set Ready	DSR	107/CC	TO VT125 The terminal receives Data Terminal Ready (DTR) from the printer on this conductor. If DSR is present at power-up, the printer controls print operations. If DSR is not present at power-up, then before each character print operation, the terminal checks again. If DSR is still not present, the print occurs. If DSR ever appears, then it controls all following prints. The terminal also uses DSR to detect the printer for the Device Attributes response (Chapter 4).
7	Signal Ground	SGND	102/AB	This conductor is the common ground reference potential for all connector signals. Also,

Table 7-2 Auxiliary Port EIA Connector Signals (Cont)

Pin	Name	Mnemonic	CCITT/EIA Designation	Description
				it is connected to the VT125 chassis.
20	Data Terminal Ready	DTR	108.2/CD	FROM VT125 This signal is always ON when the terminal is on.

### SET-UP AND COMMUNICATIONS

When you exit SET-UP, the terminal:

- updates all aspects of its operation according to any new SET-UP feature selections,
- sends XON to the computer port and auxiliary port if buffer space is available,
- clears any received XOFF to allow transmission on all ports,
- cancels any ReGIS Hard Copy operation.

NOTE: Some graphic printers have large input buffers. A cancelled Hard Copy operation may not stop for several seconds while the printer empties its buffer.

### CONTROL FUNCTIONS

The graphics processor is the control point for all communication in the VT125. (See Block Diagram, this chapter.) The graphics processor examines any ANSI control function arriving from any of the communication ports. If the graphics processor has the ability to respond to the control function, it acts on the control function and generally does not pass it along. If the graphics processor does not have a response for the control function, it ignores the control function and passes it to the device that is at the receiving end of the data path that the control function arrived on.

From the keyboard, however, a special condition applies. The Escape character (ESC) has many software applications and must be allowed to pass to the application program. The following process decides when to pass ESC:

- a. ESC is held in the graphics processor for a maximum of 50 milliseconds.

- b. If another character arrives within 50 milliseconds:
  - both characters are accepted by the graphics processor as part of a control function
  - or
  - both characters are passed immediately if the control function does not apply to the graphics processor.
- c. If no character arrives within 50 milliseconds, the ESC is passed.

50 milliseconds is a common delay between characters for a typist. Internal communications between the graphics processor and the VT100 text terminal operate with less than 20 ms delay between characters. The graphics processor does not have responses to the control functions transmitted by the special keys on the keyboard, so they are always passed through.

#### COMMUNICATION CABLES

Communications cables for both the EIA and 20 mA Current Loop interfaces of the terminal can be ordered from the DIGITAL Accessories and Supplies Group. Part numbers and ordering information for these cables is supplied in Chapter 11. Table 7-3 describes each communication cable used and Figure 7-4 shows connection examples for each cable.

#### BLOCK DIAGRAMS

The VT125 is a complex device that has several separate processes operating at the same time to provide graphics and text over a simple terminal communication line. Figure 7-5 shows a general block diagram of the VT125. This shows two main functional blocks: the graphics processor and the VT100 text terminal that holds the graphics processor. The figure shows two important facts. 1. The keyboard communicates only with the VT100, so that LOCAL operation can only cause actions in the VT100, not in the graphics processor. 2. The graphics processor manages all communications between the computer and the VT100, and always uses XON/XOFF. (This SET-UP feature cannot be turned off.)

Figure 7-6 is a more detailed look at the communication structure in the graphics processor itself. This shows the buffers that are included for each of the three bi-directional communication ports in the graphics processor. The Dispatcher is many processes. It controls the buffers with XON/XOFF. It sets up the data paths from each sending port to each receiving port. And it parses all communications according to ANSI X3.64-1979. That is, it examines data from all ports for instructions to itself. It passes anything that does not apply to the graphics processor to whichever ports are set to receive the data from that source. Among the ports controlled by the dispatcher are the selection of the graphics protocol under ANSI sequence control. The choices in that block of the diagram are ReGIS, VT105 emulation, and

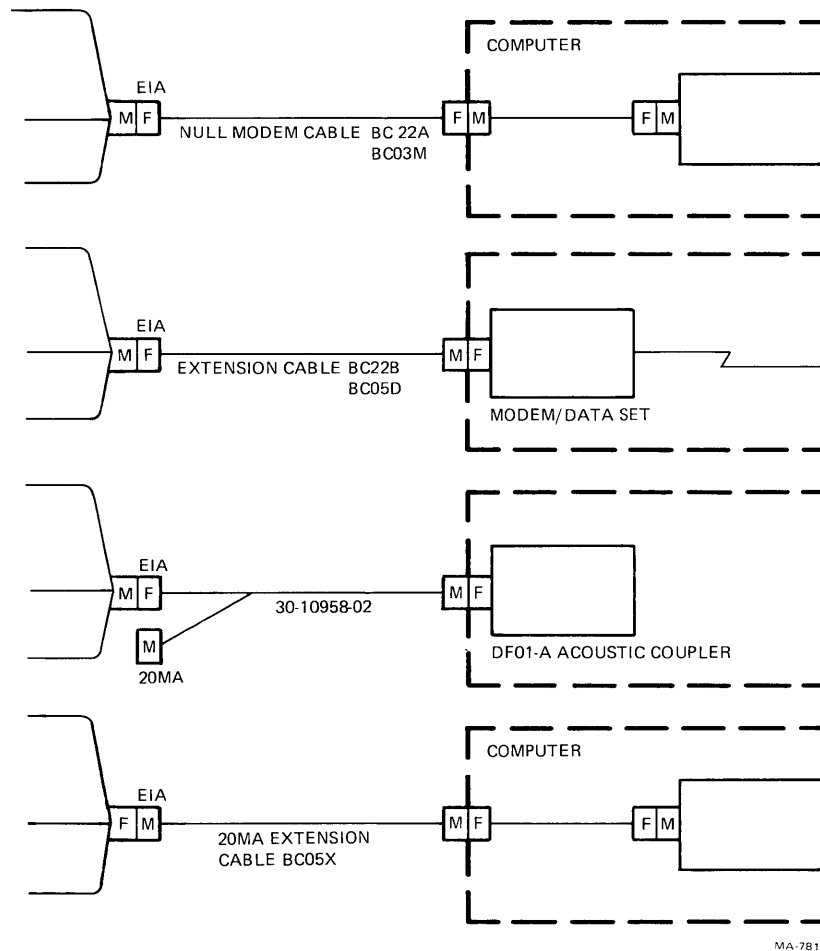

MA-7817

Figure 7-4 Cable Summary

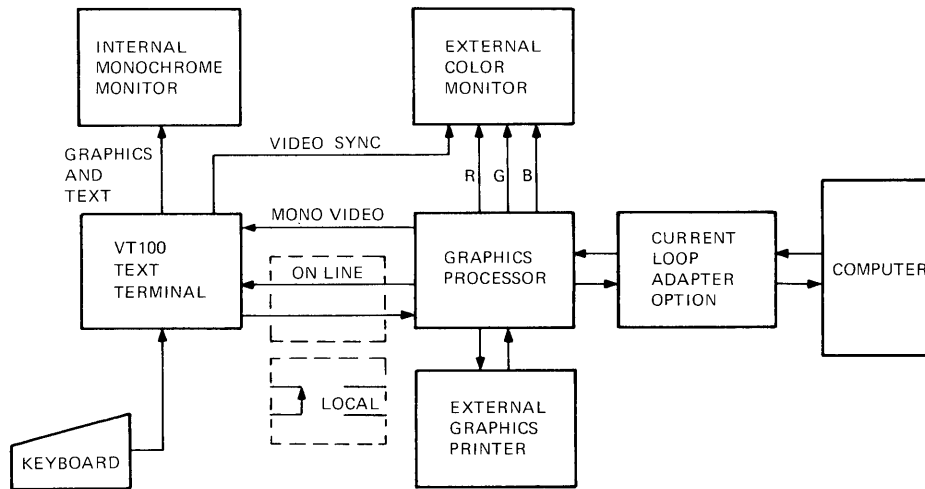

MA-9436

Figure 7-5 VT125 General Block Diagram

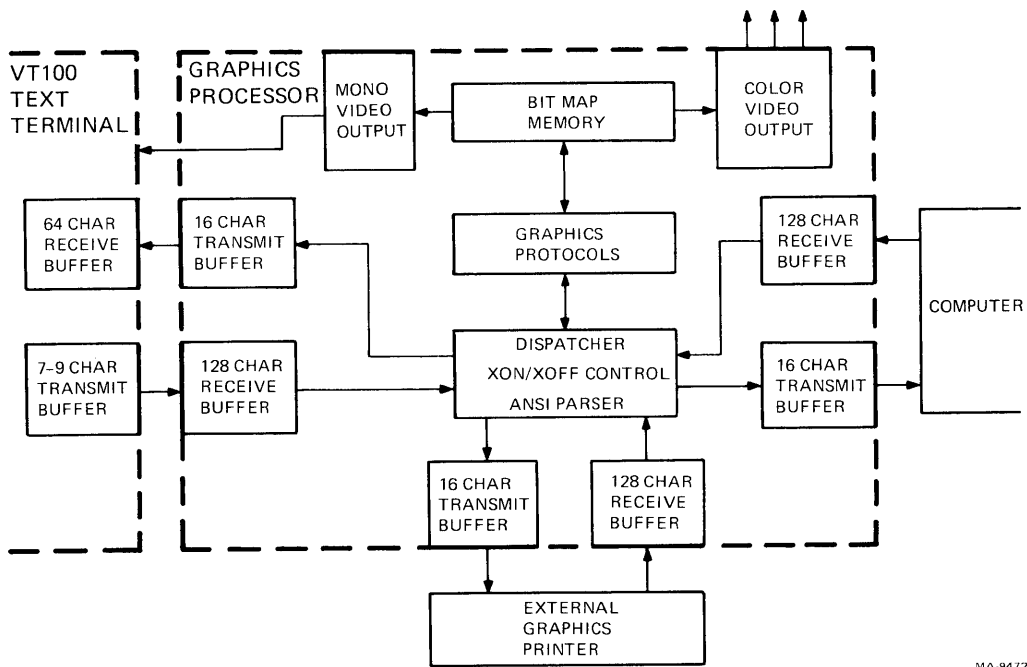

MA-9472

Figure 7-6 VT125 Data Paths

**Table 7-3 Interface Cables**

Number	Length	Connector Types	Function
BC22A-10	10 ft	RS-232 (female) to RS-232 (female)	Null modem; direct connection between VT125 and computer or printer (6-conductor cable).
BC22A-25	25 ft	RS-232 (female) to RS-232 (female)	Null modem; direct connection between VT125 and computer or printer (6-conductor cable).
BC22B-10	10 ft	RS-232 (male) to RS-232 (female)	Extension; connects VT125 to a modem (14-conductor cable).
BC22B-25	25 ft	RS-232 (male) to RS-232 (female)	Extension; connects VT125 to a modem (14-conductor cable).
BC03M-xx	variable	RS-232 (female) to RS-232 (female)	Null modem; direct connection between VT125 and computer or printer.
BC05D-xx	variable	RS-232 (male) to RS-232 (female)	Extension; connects VT125 to a modem.
BC05F-xx	variable	Mate-N-Lok (male) Mate-N-Lok (male)	20 mA; direct to connection between VT125 with a 20 mA option installed and a computer. (Supplied with 20 mA option.)
BC05X-xx	variable	Mate-N-Lok (male) to Mate-N-Lok (male)	20 mA extension cable.
30-10958-02	EIA: 18 in 20 mA: 8 ft	RS-232 (male) to RS-232 (female) and 20 mA (male)	Connection between DF01-A acoustic coupler and VT125 EIA or 20 mA.

DECwriter graphics. The following five figures show the internal connections that are set up for different applications.

Figure 7-7 shows the VT125 operating as a text-only terminal. This is how the terminal operates when it is first powered up. If you send XOFF from the keyboard, either by pressing NO SCROLL (if

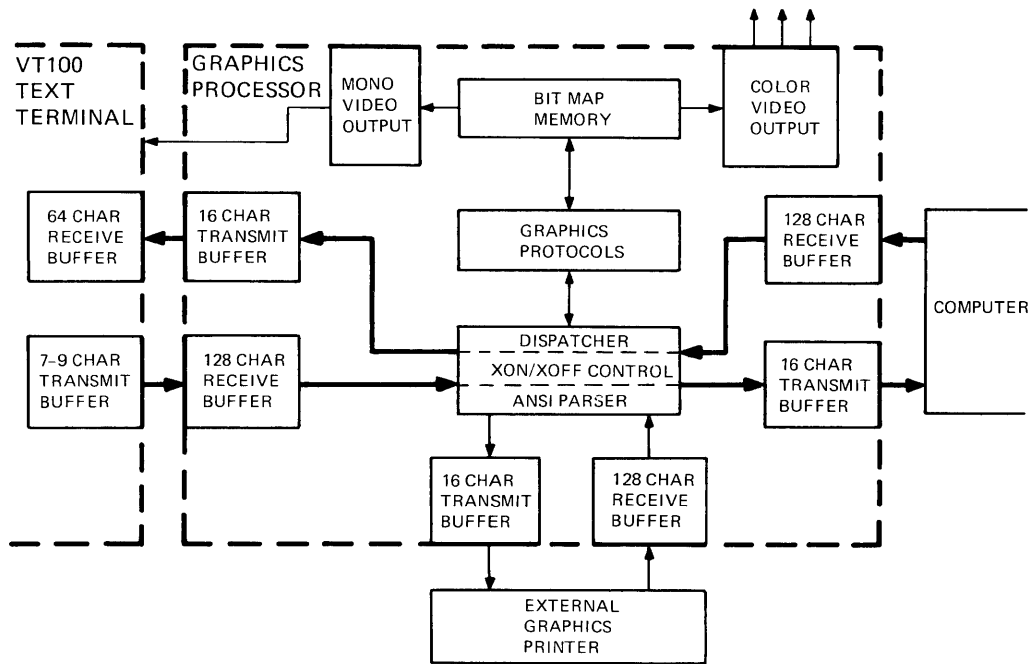

MA-9475

Figure 7-7 VT125 as Text-Only Terminal



AUTO XON/XOFF is on) or by pressing the S key while pressing the CTRL key, the receive buffer in the VT100 fills to the 32 character mark. Then the VT100 sends XOFF to the graphics processor. When the 16 character transmit buffer in the graphics processor fills, it sends XOFF to the dispatcher, and then the 128 character receive buffer fills to its 48 character mark. At that point, 80 characters later, the graphics processor sends XOFF to the computer.

Figure 7-8 shows the VT125 operating as a graphics terminal. A Device Control String is being sent to the terminal from the computer. The terminal may be in any protocol: ReGIS, VT105, or DECwriter graphics. The keyboard can communicate with the computer, but any screen response to keyboard commands is under the control of the computer's programming.

Figure 7-9 shows the VT125 operating as a graphics terminal. A Device Control String is being sent to the terminal from the computer. The graphics protocol commands are being displayed on the screen at the same time. This is a feature of VT125 ReGIS and is not available with the other protocols. The keyboard can communicate with the computer, but any screen response to keyboard commands is under the control of the computer's program.

Figure 7-10 shows the VT125 printing from the screen to the optional graphics printer in DECwriter graphics protocol. This is the result of the Screen Hard Copy command in ReGIS. The keyboard can communicate with the computer, but the computer cannot communicate with the dispatcher until the print operation is complete. However, if a Graphics Off command (String Terminator: ESC \) immediately follows the Hard Copy command, the computer can communicate with the dispatcher during the print operation.

Figure 7-11 shows the VT125 printing from the computer to the optional printer. This is the result of the ANSI Media Copy command from the computer. The Media Copy command can turn the VT100 and auxiliary (printer) ports on and off. Therefore, the screen could display the data that is going to the printer if wanted. To print a stored DECwriter graphics protocol file, display it on the screen and then use the ReGIS Hard Copy command to print it.

#### INPUT BUFFER OVERFLOW PREVENTION

When the terminal receives a character (other than the NUL and DEL characters), the character is placed in a 128 character input buffer. The input buffer holds the received character until the dispatcher processes the character. When processed, the character is removed from the input buffer.

If received characters are placed in the input buffer faster than the characters are processed, the input buffer begins to fill with characters. If the input buffer becomes full, all new characters received are lost and the Substitute character (OD) is displayed.

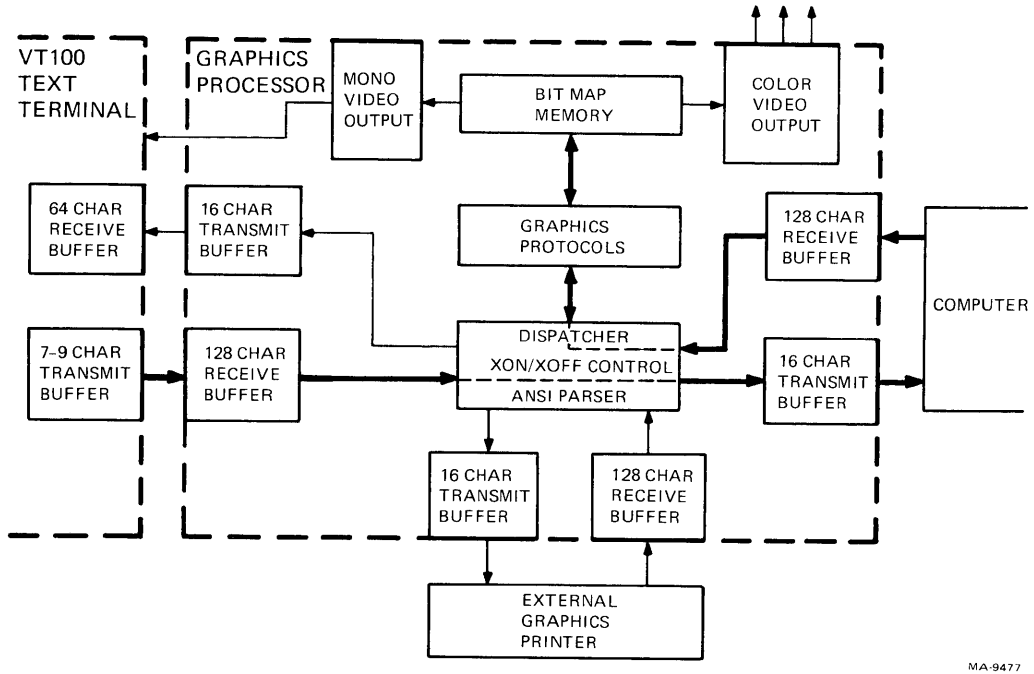

MA-9477

Figure 7-8 VT125 in a Graphics Protocol

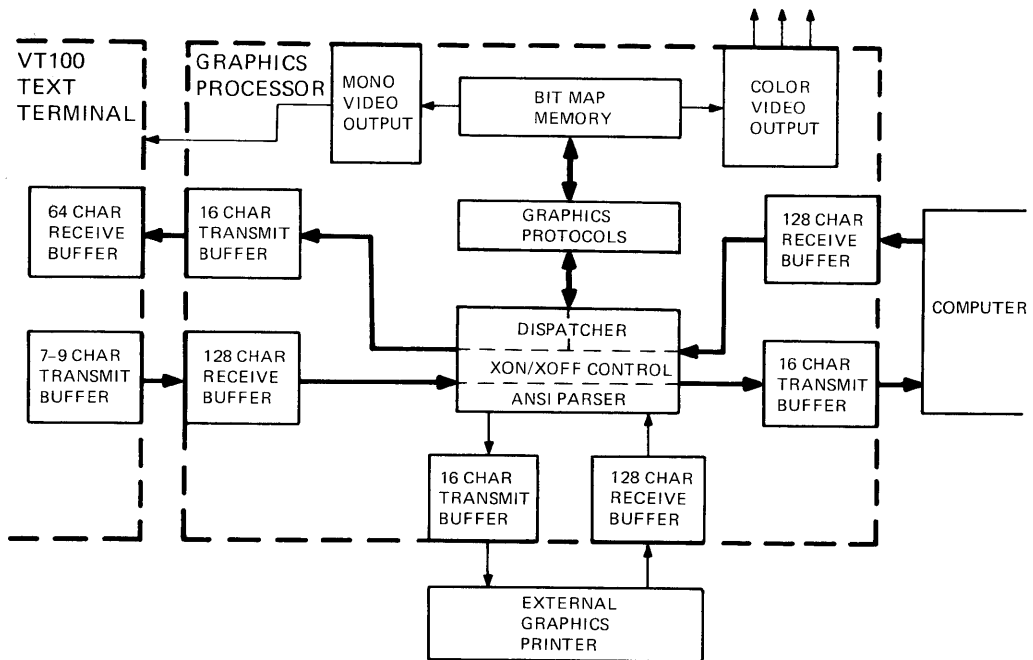

MA-9474

Figure 7-9 VT125 in ReGIS Graphics with Commands on Screen

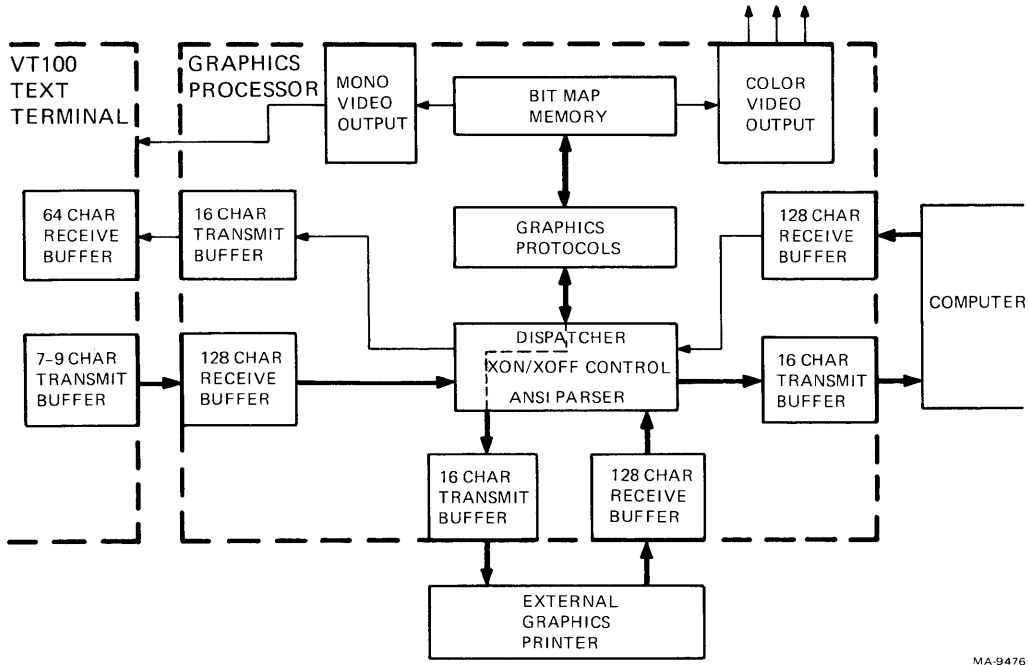

Figure 7-10 VT125 Printing from Screen

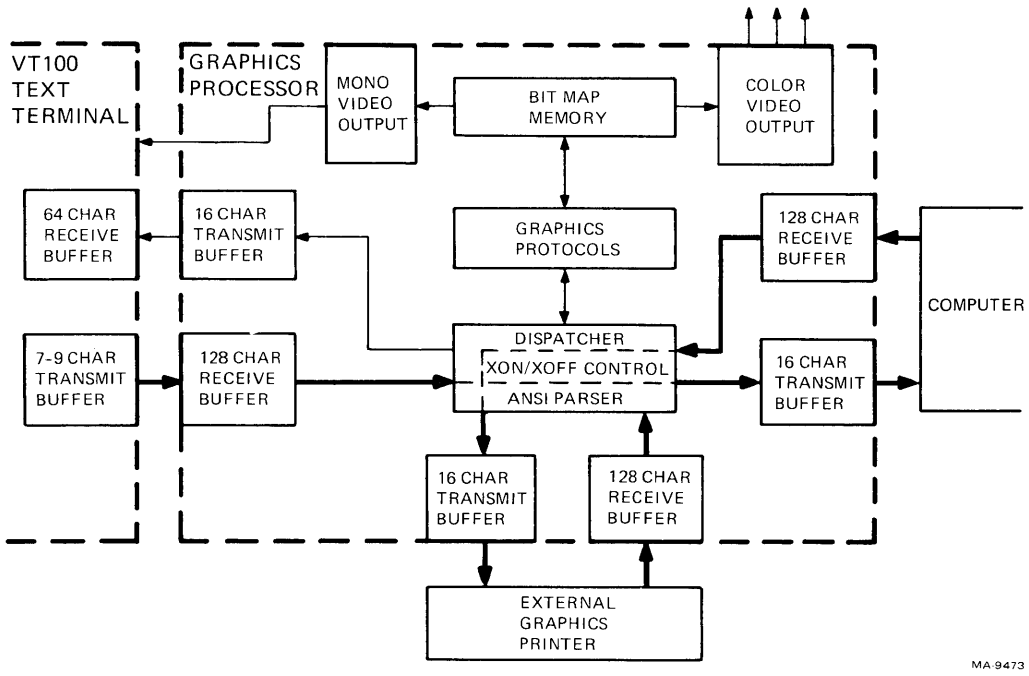

Figure 7-11 VT125 Printing from Computer

Using XON and XOFF characters between the terminal and the devices it communicates with prevents input buffer overflow. The graphics processor always has an automatic XON/XOFF protocol in operation. The many different operations that the processor can perform, from graphics protocols to local printing, take widely different amounts of time to perform. The techniques of Fill Characters and Low Speed Operation that are suggested as alternate methods of buffer overflow prevention for the VT100 text terminal cannot be used with the VT125 graphics terminal.

#### XON and XOFF Control Characters

The XON and XOFF control characters indicate the number of characters in an input buffer. When the 128 character input buffer of the graphics processor holds 48 characters, the graphics processor transmits XOFF (DC3, octal 023). The computer or other device should stop transmitting characters.

As the dispatcher removes characters from the input buffer, the number of characters in the buffer decreases. When the input buffer holds 16 characters, the graphics processor transmits XON (DC1, octal 021) requesting the computer to continue transmission.

If the computer fails to respond to the XOFF character transmitted by the graphics processor, the input buffer continues to fill. The graphics processor transmits a second XOFF when the input buffer holds 112 characters. This second XOFF is a last request to the computer to stop transmitting characters before overflow. Then, an overflow at 128 characters transmits a final XOFF.

To determine how fast the computer must respond to the first XOFF character to avoid input buffer overflow, use the following formulas:

No. of characters to overflow =  $80 - [3 \times (\text{receiver speed} / \text{transmit speed})]$

Time to respond to XOFF = No. of characters to overflow X  
(bits per character + parity bit + number of stop bits + 1)/receiver speed.

#### Example 1:

The graphics processor transmits and receives 8-bit characters with no parity at 1200 baud. When the graphics processor transmits the first XOFF, the computer must stop transmitting within 0.608 seconds or the input buffer overflows.

No. of characters to overflow =  $80 - [3 \times 1200/1200] = 73$  characters

Time to respond to XOFF =  $73 \times (8+0+1+1)/1200 = 0.608$  second

Example 2:

The graphics processor is transmitting and receiving 7-bit characters with parity at 300 baud. When the graphics processor transmits the first XOFF, the computer must stop transmitting within 2.4 seconds or the input buffer overflows.

No. of characters to overflow =  $80 - [3 \times 300 / 300] = 73$  characters

Time to respond to XOFF =  $73 \times (7+1+1+1) / 300 = 2.4$  seconds

NOTE: If the input buffer overflows, received characters are ignored and the Substitute character (OD) is displayed.

**EFFECTS OF RESET AND TESTS**

Two control sequences, Reset and Invoke Confidence Test, initialize the terminal and erase all buffers. This means that characters received while these two functions are processed are lost. Therefore, immediately after sending the Reset or Invoke Confidence Test sequences, the computer should assume that it received an XOFF from the terminal. The computer should then send no more characters until it receives XON. The terminal transmits XON only after it completes the test.

NOTE: The Reset and Invoke Confidence Test sequences may cause the terminal to disconnect from the communication line.

**TRANSMIT BUFFERS**

The transmit buffers hold characters generated by the terminal before they are transmitted to the computer. The computer can use the XON (DC1, octal 021) and XOFF (DC3, octal 023) characters to control the transmission of characters from the terminal.

Receipt of XOFF stops the graphics processor from transmitting any characters except XOFF and XON. When the 16 character transmit buffer fills, the dispatcher stops accepting characters from the receive buffer of the port that is transmitting (for example, the VT100). When the receive buffer fills with 48 characters, it sends XOFF to its sender (in this example, the VT100). It transmits a second XOFF if the buffer fills to 112 characters. From seven to nine characters are stored in the VT100 keyboard buffer. (Some keys transmit three characters at once. The buffer locks at 7 characters to prevent loss of the added characters of a three character keystroke.) If the keyboard buffer fills, the KBD LOCKED indicator turns on and keyclicks stop (if the Keyclick SET-UP B feature is on).

Receipt of XON starts the transmission of characters again. The 16 character transmit buffer empties and the dispatcher moves characters from the receive buffer to the transmit buffer. When the receive buffer empties to the 16 character level, it sends XON to the transmit buffer in the VT100. (Also, entering and exiting SET-UP turns off the KBD LOCKED indicator and allows the VT100 to transmit characters. However, characters transmitted after entering and exiting SET-UP may be lost if the receive buffer is

not ready to receive characters.) When the keyboard buffer empties, the KBD LOCKED indicator turns off and keyclicks occur when keys are pressed (if the keyclick feature is ON).

## CHAPTER 8 INSTALLATION

### GENERAL

This chapter contains the information needed to unpack, pack, and install the VT125 terminal. The Installation Procedure describes how to select the proper input voltage selection and fuse for either 120 or 220 -- 240 VAC operation. The Power Up and Checkout Procedure provides a step-by-step procedure for powering up the VT125 terminal.

### SITE CONSIDERATIONS

The VT125 terminal is made up of a video monitor and a detachable keyboard. Their dimensions are shown in Figure 8-1. Table 8-1 lists the environmental and power specifications of the terminal. If the terminal will be used with a color video monitor, you must get four video cables that are long enough for your location.

NOTE: When installing the terminal, make sure that all power and signal cables are free from any stress, sharp bends, or obstructions. Also, be sure to provide access to the power switch on the back of the terminal.

Be sure not to block air flow around the terminal. There are several ventilation openings to prevent the terminal from overheating. Do not block these openings by placing objects on top or under the terminal. Also, do not allow liquids, coins, paper clips, and other objects to enter these ventilation openings. These objects may cause damage to the terminal. For this reason, do not put drinks or metal objects on the top of terminal.

The terminal may be placed on a desk or table top. However, people ususlly prefer the keyboard at standard typewriter table height rather than desk height. Terminal tables and stands are available from DIGITAL Accessories and Supplies Group. (Refer to Chapter 11 for more information on Accessories.)

Position the terminal to avoid reflected light. Usually, the terminal is positioned facing away from light sources that reflect off the screen. However, if reflected light is a problem, non-reflective and anti-glare screens are available from DIGITAL Accessories and Supplies Group. Also, anti-static mats are available from DIGITAL Accessories and Supplies Group for installations with static electricity problems.

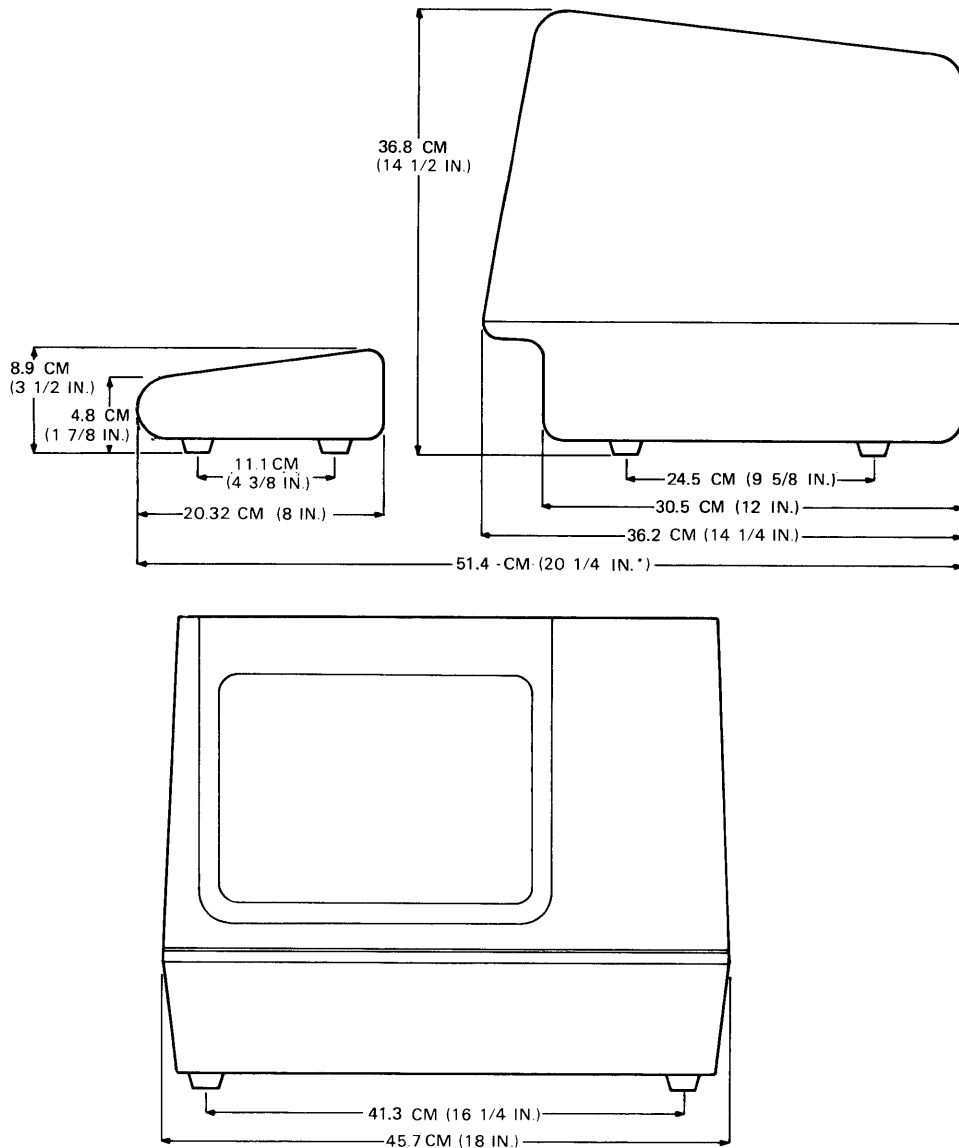

\* MEASUREMENT TAKEN WITH THE KEYBOARD PLACED FLUSH TO FRONT OF TERMINAL UNDER UNDERCUT.

MA-1991

Figure 8-1 VT125 Terminal Dimensions



**Table 8-1 Site Considerations**

Site Consideration	Specification
Temperature	100 to 400 C (500 to 1040 F)
Relative Humidity	10 to 90 percent with a maximum wet bulb temperature of 280 C (820 F) and a maximum dew point of 20 C (360 F) noncondensing
Input Voltage	90 to 128 VAC 180 to 256 VAC (switch selectable)
Power Consumption	250 VA apparent, 150 W maximum
Power Receptacle	Nonswitched, grounded

**INSPECTION**

The VT125 terminal is packed in a reinforced carton containing the following items:

- Monitor
- Keyboard
- AC Power Cord
- SET-UP Label
- User Guide
- Programming Reference Card

Inspect the terminal for damage and check that all the listed items are present.

NOTE: If damaged, notify the carrier and your local DIGITAL Sales Office.

**INSTALLATION PROCEDURE**

The VT125 terminal can be installed using a 3 mm (1/8 in) blade screwdriver. However, more tools may be needed when installing any accessories and options. To install the VT125 terminal, use the following general procedure (refer to Figure 8-2 for the switch and cable locations):

1. Unpack and inspect the terminal.
2. Check the terminal for the proper voltage range selection. The terminal can operate with either 120 VAC or 220 -- 240 VAC input power.

CAUTION: Failure to select the proper voltage range will damage the terminal.

A label over the power receptacle indicates the factory selected input voltage range. Check this label and the Voltage Selection switch to be sure that the voltage

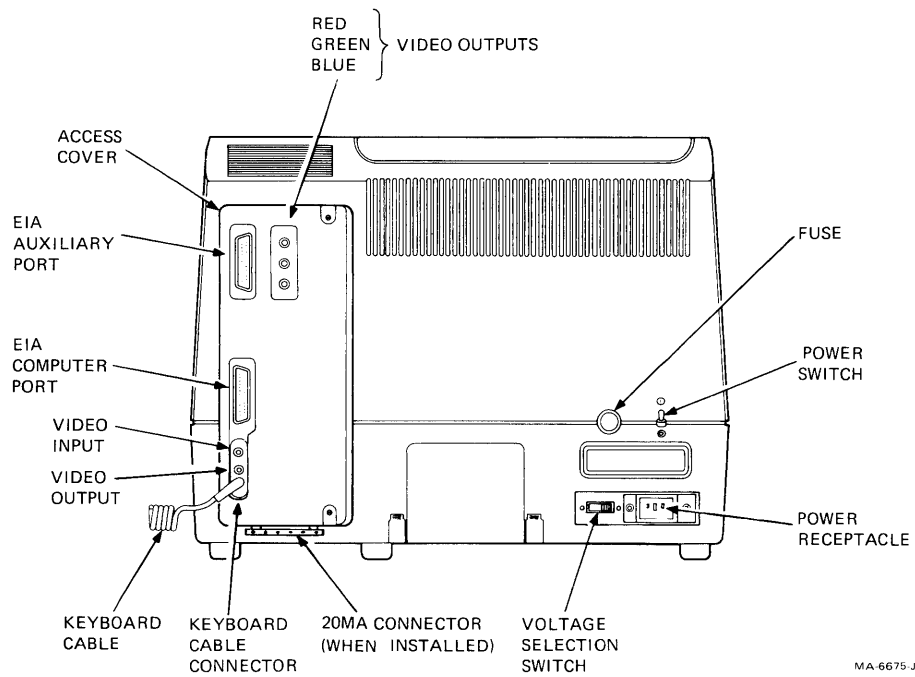

Figure 8-2 Monitor Controls and Connector Location

range of the terminal is the same as your local ac power source. Select the proper input voltage range if needed.

- c. Install the correct power cable for your power source. (A list of available cables is in Chapter 11.
3. Attach the SET-UP label to the bottom of the keyboard. Remove the backing paper on the self-sticking SET-UP label, then attach the label.
4. Place the keyboard in front of the terminal and plug the keyboard into the keyboard connector located at the back of the terminal.
5. Connect the ac power cable to a nonswitched, grounded ac power receptacle.

NOTE: Check to be sure the Power switch is in the off position before connecting the power cord.

6. Perform the Power Up and Checkout procedure in this chapter. When the Power Up and Checkout Procedure is completed continue this installation procedure.
7. Turn off the power and disconnect the power cord.
8. If needed, install the Advanced Video Option (VT1XX-AB) and the 20 mA Current Loop Option (VT1XX-AA) at this point in the installation procedure. Perform the option installation and option checkout procedures in Chapter 10.
9. Connect the communication cable to the appropriate connector at the back of the terminal. If using the EIA interface, fasten the connector to the terminal with the captive screws using a 3 mm (1/8 in) blade screwdriver. Be sure to attach the cable ground wire to one of the captive screws (Figure 8-3). (Refer to Chapter 5 for information about connector use and signal/pin definitions.)
10. Connect an optional external video monitor. If the monitor is color, use three video cables to connect the Red, Green, and Blue outputs from the VT125 to the inputs on the monitor. See Figure 8-2. Connect the composite video output from the VT125 to the sync input on the monitor, and set the monitor to select external synchronization.

If the monitor has the ability to pass the video signals to another device ("loopthrough"), be sure that either the monitor (if alone) or the last device in the string is set to terminate the video and sync signals in 75 ohms.

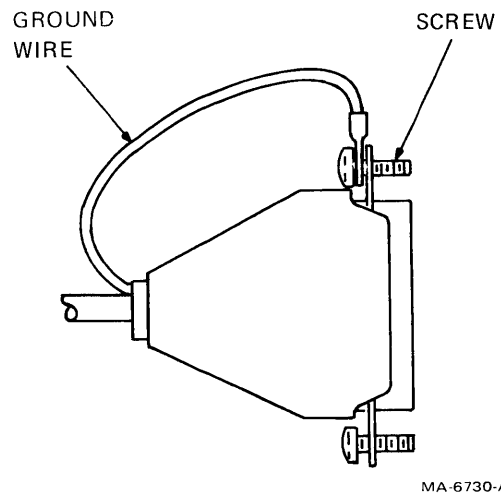

Figure 8-3 Interface Cable  
Ground Connection

If the external monitor is monochrome (black and white), connect only the composite video output from the VT125 to the monitor input. Be sure the video signal is terminated in 75 ohms. The video output signals and the other connector, the video input, are described in detail in Appendix A.

11. Connect an optional printer to the auxiliary port. See Chapter 7 Communication, Chapter 2 SET-UP, and the printer's user guide for information about setting the communication features of both the printer and the auxiliary port to the same values.

Performing these procedures completes the installation of the terminal.

#### POWER UP AND CHECKOUT PROCEDURE

A Power Up Self Test verifies the proper operation of the VT125 terminal each time the terminal is powered up. Perform the following procedure to power up and checkout the terminal:

1. Turn the Power switch to the on position (refer to Figure 8-2 for the switch location). The terminal automatically runs the Power Up Self Test. The test gives the following indications:
  - Keyboard and screen flash on and off.
  - All keyboard indicators turn on and off, and either the ON LINE or LOCAL indicator is turned on.
  - The Wait message is displayed on the screen and then is erased.
  - A bell tone is generated.
  - A band of light appears at the top of the screen and is erased.
  - Another bell tone is generated.
  - A message appears to announce the result of the VT125 self-test, and a box is drawn\* around the margins of the graphics screen area. (This message stays on the screen until the first character arrives over the communication line.)

NOTE: No messages appear on the screen until the terminal warms up.

---

\* Not on all units.

- The text cursor is displayed in the upper-left corner of the screen.

Any error found by the Power Up Self Test is displayed on the screen as a character, as a message, on keyboard indicators L1-L4, or by several bell tones. Refer to the Self Test Error Codes section of Chapter 9 for more information about the error indications.

2. If the terminal powers up correctly, continue with the installation procedure if you are going to install any options. Then select the SET-UP features you want as described in Chapter 2.
3. When the SET-UP features are selected, record the feature selections on the SET-UP label attached to the bottom of the keyboard.

CHAPTER 9  
OPERATOR MAINTENANCE AND TROUBLESHOOTING

**GENERAL**

This chapter describes maintenance procedures, troubleshooting (what to do in the event of a problem) and self tests used with the VT125 terminal. Try to troubleshoot the terminal yourself before requesting service.

**MAINTENANCE**

The VT125 terminal needs no preventive maintenance. However, its cabinet may be cleaned with any mild detergent that does not use solvents. When cleaning the terminal:

CAUTION: Do not use too much detergent when cleaning the terminal. If liquids get inside the terminal, the terminal may be damaged.

- To clean the surfaces of the terminal, apply the detergent to a cloth or tissue and then clean the terminal.
- To clean the screen, apply the detergent to a cloth or tissue and then clean the screen.
- To clean the keys, rub with a dry or moist cloth.

CAUTION: Do not remove the keycaps when cleaning; the keyswitch contacts can be damaged if the keycaps are replaced incorrectly.

**WHAT TO DO IN THE EVENT OF A PROBLEM**

If the terminal appears to be faulty, perform the following procedure. If the problem is not solved by this procedure, refer to Table 8-1 for a list of typical problems.

1. Turn the Power Switch to the off position and check the following:
  - a. Power Cord -- be sure the cord is connected securely at both the terminal and at the wall outlet. Check the wall outlet with another device such as a lamp to be sure that it is providing ac power.
  - b. Voltage Selection Switch and Fuse -- be sure the switch is in the correct position and the fuse is

good. (Remove the fuse holder cap by pressing it in and turning it counter-clockwise. Replace the fuse holder cap by pressing it in and turning it clockwise.)

- c. Keyboard Coiled Cord -- check that the cord is securely plugged into the keyboard connector at the back of the terminal.
2. Turn the Power Switch to the on position, the terminal performs the Power Up Self Test. (Refer to the Power Up Self Test Description for more information about the power up test.) If the terminal does not power up correctly, call your local DIGITAL service office.
3. If needed, perform the Computer Port Data Loopback Self Test with an optional EIA loopback connector (see Chapter 11 for ordering information). (Refer to the Loopback Test descriptions in this chapter for more information.)

#### VT125 SELF TESTS

The VT125 terminal has several self tests available for checking the operation of the terminal. Some of these are the self tests of the VT100 terminal that the VT125 graphics processor resides in. The other tests are for the graphics processor itself.

The Power Up Self Test is performed each time the terminal is powered up. The other tests may be performed after the Power Up Self Test is completed. To perform the other tests the terminal must be disconnected from the communication line and an external loopback connector installed.

#### POWER UP SELF TEST

A Power Up Self Test is built into the VT125 terminal to test the operation of the terminal. The test checks the general operation of the VT100 terminal, including the Advanced Video Option if installed, the user permanent SET-UP feature memory and the keyboard, and the general operation of the graphics processor, including the bit map memory.

To perform the Power Up Self Test, turn the terminal on, or if power is on, enter SET-UP and press the 0(RESET) key. Prepare the terminal with the following procedure if the test must be run continuously:

1. With the Power switch off, disconnect the communication cable and install the loopback connector on the EIA connector, refer to Figure 8-1. The EIA loopback connector part number is 12-15336. If the 20 mA Current Loop Adapter Option is installed, use the loopback connector (pn 70-15503-00) that was included with the option. Do not use the EIA loopback connector at the same time as the current loop connector.
2. Turn the Power switch on.



Table 9-1 Problem Checklist

Symptom	Possible Cause	Corrective Action
ON LINE or LOCAL indicator on with no cursor on screen.	Screen Brightness too low.	Enter SET-UP and increase the screen brightness.
ON LINE or LOCAL indicators not on with no keyboard response. Cursor on screen.	Keyboard cable not connected to terminal.	Turn off terminal and connect keyboard cable.
KBD LOCKED indicator on.	Keyboard buffer full, keyboard cannot accept more characters. Terminal was XOFFed by computer.	Entering and Exiting SET-UP clears this condition. Caution: characters may be lost using this procedure.
Terminal does not respond to typed characters. Keyclicks generated and keyboard indicators function.	Screen can not be updated by the Computer. Terminal XOFFed Computer.	Press the NO SCROLL key. or Enter and exit SET-UP.
Wrong or Substitute (⌘) characters or no characters appearing on the on the screen.	Incorrect SET-UP feature selection	Correct the SET-UP features. Suggested SET-UP features that may be in error: ANSI/VT52 Mode Auto XON/XOFF Bits per character Parity Parity sense Receive Speed Transmit Speed
	Computer error	Check computer system.
Several bell tones during power up, Reset or Recall.	Read or write problem with user permanent memory.	Check the SET-UP feature settings and try the Save operation.

3. Be sure the terminal is ON LINE with the ANSI/VT52 SET-UP B feature selected to ANSI (SET-UP B switch 2-3 = 1). Type one of the following sequences to perform the test.

ESC [ 4 ; 1 y                      Performs the Power Up Self Test once.

ESC [ 4 ; 9 y                      Performs the Power Up Self Test continuously.

NOTES: This test can also be performed with the VT100 power-up test sequence (<ESC>[2;ly). The continuously running test ends only if an error is found or if power is turned off.

The test gives the following indications:

- Keyboard and screen flash on and off.
- All keyboard indicators turn on and off, and either the ON LINE or LOCAL indicator is turned on.
- The Wait message is displayed on the screen and then is erased.
- A bell tone is generated.
- A band of light appears at the top of the screen and is erased.
- Another bell tone is generated.
- A message appears to announce the result of the VT125 self-test, and a box is drawn\* around the margins of the graphics screen area.

NOTE: No messages appear on the screen until the terminal warms up.

- The text cursor is displayed in the upper-left corner of the screen.

Any error found by the Power Up Self Test is displayed on the screen as a character, as a message, on keyboard indicators L1-L4, or by several bell tones. Refer to the Self Test Error Codes section of this chapter for more information about the error indications.

#### COMPUTER DATA PORT LOOPBACK SELF TEST

The Computer Port Data Loopback test checks that the VT125 terminal can transmit and receive characters over the computer

---

\* Not on all units.

data port. The transmit and receive lines must be connected to each other with an external loopback connector.

To perform the Data Loopback Self Test, use the following procedure:

1. With the Power switch off, disconnect the communication cable and install the loopback connector on the computer data port connector. See Figure 8-1. The EIA loopback connector part number is 12-15336. If the 20 Ma Current Loop Adapter Option is installed, use the loopback connector (pn 70-15503-00) that was included with the option. Do not use the EIA loopback connector at the same time as the current loop connector.
2. Turn the Power switch on. The terminal performs the power up self test.
3. Be sure the terminal is ON LINE with the ANSI/VT52 SET-UP B feature selected to ANSI (SET-UP B switch 2-3 = 1). The transmit and receive speeds must be the same and 300 baud or faster. Type one of the following sequences to perform the test.

ESC [ 4 ; 1 ; 2 y                      Performs the Power Up and  
Computer Data Port loopback  
self tests.

ESC [ 4 ; 1 ; 2 ; 9 y                  Performs the Power Up and  
Computer Data Port loopback  
self tests continuously until  
failure.

NOTE: The continuously running test ends only if an error is found or if power is turned off.

The test gives the following indications:

- Either the ON LINE or LOCAL indicator is turned on.
- The Wait message is displayed on the screen and then is erased.
- The cursor is displayed in the upper-left corner of the screen.
- If the Computer Data Port loopback test fails, the message "VT125 EC Error" is displayed on the internal monitor.

4. Turn the Power Switch off, remove the loopback connector and connect the communication cable.

## AUXILIARY PORT LOOPBACK TEST

The Auxiliary Port Data Loopback test checks that the VT125 terminal can transmit and receive characters over the auxiliary data port. The transmit and receive lines must be connected to each other with an external loopback connector.

To perform the Auxiliary Port Data Loopback Test, use the following procedure:

1. With the Power switch off, disconnect any cable from the auxiliary port and install the EIA loopback connector. See Figure 8-1. The EIA loopback connector part number is 12-15336.
2. Turn the Power switch on. The terminal performs the power up self test.
3. Be sure the terminal is ON LINE with the ANSI/VT52 SET-UP B feature selected to ANSI (SET-UP B switch 2-3 = 1). Type one of the following sequences to perform the test.

ESC [ 4 ; 1 ; 3 y                      Performs the Power Up and  
Auxiliary Data Port loopback  
self tests.

ESC [ 4 ; 1 ; 3 ; 9 y                  Performs the Power Up and  
Auxiliary Data Port loopback  
self tests continuously until  
failure.

NOTE: The continuously running test ends only if an error is found or if power is turned off.

The test gives the following indications:

- Either the ON LINE or LOCAL indicator is turned on.
  - The Wait message is displayed on the screen and then is erased.
  - The cursor is displayed in the upper-left corner of the screen.
  - If the test fails, the message "VT125 SC Error" is displayed.
4. Turn the Power Switch off, remove the loopback connector and connect the communication cable.

## DISPLAY TEST

This test requires that you check the screen of the internal monitor and the color monitor (if present) for correct operation. The screen cycles through the four intensity levels of each of the three primaries and white to test the output memory. The computer data port must have the loopback connector installed.

Table 9-2 Display Test Indications

	Monochrome				Color			
Step 1	Black	White	Light Grey	Dim Grey	Black	Light Red	Black	Black
Step 2	Dim Grey	Black	White	Light Grey	Dim Blue	Dim Red	Dim Green	Dim Grey
Step 3	Light Grey	Dim Grey	Black	White	Light Blue	Light Red	Light Green	Light Grey
Step 4	White	Light Grey	Dim Grey	Black	Light Green	Light Red	Light Blue	Black
Step 5	White	Light Grey	Dim Grey	Black	Black	Black	Black	Black

To perform the Display Test, use the following procedure:

1. With the Power switch off, disconnect the communication cable and install the loopback connector on the computer data port connector. See Figure 9-1. The EIA loopback connector part number is 12-15336. If the 20 Ma Current Loop Adapter Option is installed, use the loopback connector (pn 70-15503-00) that was included with the option.

Do not use the EIA loopback connector at the same time as the current loop connector.

2. Turn the Power switch on. The terminal performs the power up self test.
3. Be sure the terminal is ON LINE with the ANSI/VT52 SET-UP B feature selected to ANSI (SET-UP B switch 2-3 = 1). Type one of the following sequences to perform the test.

ESC [ 4 ; 1 ; 4 y                      Performs the Power Up and Display self tests.

ESC [ 4 ; 1 ; 4 ; 9 y                  Performs the Power Up and Display self tests continuously until failure.

NOTE: The continuously running test ends only if an error is found or if power is turned off.

The test gives the indications listed in Table 9-2.

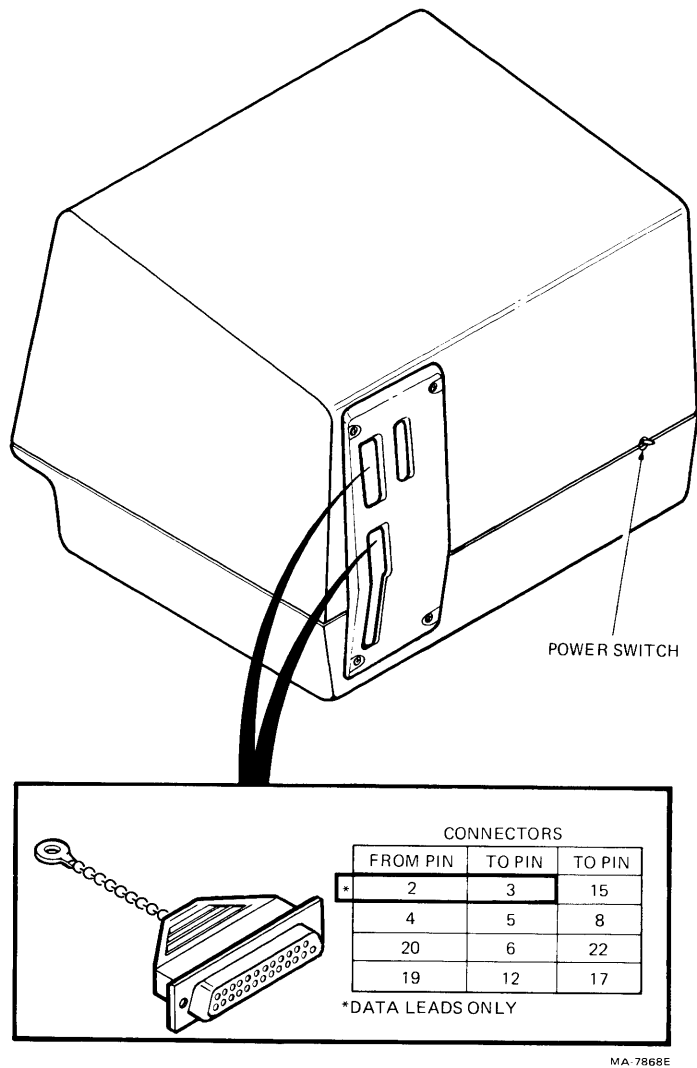

Figure 9-1 EIA Loopback Connector

## VIDEO BIT MAP MEMORY TEST

This test checks that every bit in both video bit map planes can be written to both one and zero. The computer data port must have the loopback connector installed.

To perform the Video Bit Map Memory Test, use the following procedure:

1. With the Power switch off, disconnect the communication cable and install the loopback connector on the computer data port connector. See Figure 8-1. The EIA loopback connector part number is 12-15336. If the 20 Ma Current Loop Adapter Option is installed, use the loopback connector (PN 70-15503-00) that was included with the option. Do not use the EIA loopback connector at the same time as the current loop connector.
2. Turn the Power switch on. The terminal performs the power up self test.
3. Be sure the terminal is ON LINE with the ANSI/VT52 SET-UP B feature selected to ANSI (SET-UP B switch 2-3 = 1). Type one of the following sequences to perform the test.

ESC [ 4 ; 1 ; 5 y                      Performs the Power Up and Video Bit Map Memory tests.

ESC [ 4 ; 1 ; 5 ; 9 y                  Performs the Power Up and Video Bit Map Memory tests continuously until failure.

NOTE: The continuously running test ends only if an error is found or if power is turned off.

The test gives the following indications:

- The screen fills with levels of intensity (or color) moving from top to bottom.
- If this test fails, the message "VT125 BM Error" is displayed.

## VT125 SELF TEST ERROR CODES

If any of keyboard indicators L1 through L4 are lit at the end of power-up self-test, or if the complete screen flashes, request service for the terminal.

If a character appears under the blinking cursor at the top left corner of the screen, or a message appears in the center of the screen, check Table 9-3 for the meaning of the error code character or message. Note that the character displayed could mean that more than one error has been detected. To clear the error indication after the error is corrected, Reset or Power up the terminal.

**Table 9-3 Displayed Error Codes**

Character Displayed	Faults Detected		
	AVO	Memory	Keyboard
1	X		
2		X*	
3	X	X	
4			X**
5	X		X
6		X	X
7	X	X	X

Message Displayed	Faults Detected
VT125 OK	None - normal power up test results
VT125 Offline	VT100 text terminal is LOCAL. LOCAL was saved in SET-UP, or User Permanent Memory problem.
VT125 BM Error	Video Bit Map Memory. One or more bad pixels.
VT125 VG Error	Vector Generator
VT125 IC Error	Internal Communications
VT125 SC Error	Auxiliary Port
VT125 EC Error	Computer Port

- \* Also, bell tones generated - perform a Save and Recall in SET-UP
- \*\* Be sure keyboard is properly connected

There are three types of errors indicated by the self test code characters. They are:

- **Advanced Video Option (AVO) if installed**      If the advanced video option fails, the terminal operates with the basic VT100 text capabilities.
- **User Permanent SET-UP Feature Memory failure (Memory)**      If the user permanent SET-UP feature memory fails, the terminal operates using default SET-UP feature selections for each of the features. (Refer to Chapter 2 for more information on the SET-UP feature memories.)
- **Keyboard missing or malfunction (Keyboard)**      If only the keyboard fails, the terminal ends the test ON LINE, so that it may operate as a



receive-only terminal. The SET-UP feature selections cannot be changed.

There are six types of errors indicated by the Self Test error messages. They are:

VT125 Offline	VT100 text terminal is LOCAL. LOCAL was saved in SET-UP, or User Permanent Memory problem. Terminal can only process received graphics commands.
VT125 BM Error	Video Bit Map Memory has one or more bad pixels.
VT125 EC Error	Computer Port failed data loopback test. Terminal can only operate as text terminal in LOCAL.
VT125 IC Error	Internal Communications failure. VT125 cannot communicate with VT100. Terminal can only process received graphics.
VT125 SC Error	Auxiliary Port failed data loopback test. Terminal cannot send data to printer.
VT125 VG Error	Vector Generator could not draw sample shape. Graphics probably does not work, but terminal may communicate normally.

A box is drawn around the margin of the graphics screen area.\* If any part of the box is missing or distorted, the graphics board needs service.

Table 9-3 shows the possible error characters that are displayed on the screen and the failure indicated by each character. Notice that the character displayed could indicate that more than one error has been found.

---

\* Not on all units.



### GENERAL

The VT125 Graphics Terminal is a VT100 text terminal with a factory installed graphics processor. There are two more options that can be installed into the VT125 at its operating location. They are the 20 mA Current Loop Option and the Advanced Video Option. Other options that can be used with the VT125 are a color monitor and a graphics hard copy printer. Installation of the monitor and printer is explained in the installation chapter. This chapter explains the installation of options into the VT125 itself.

This chapter also explains the installation of the VT1XX-CB and -CC Graphics processors into the VT100 and VT105.

### 20 MA Current Loop Interface Option (VT1XX-AA)

#### Description

The 20 mA Current Loop Option is an optional interface used to connect the VT125 terminal to a computer. The 20 mA option is a board installed into the VT125 terminal and an interface connector. Figure 10-1 shows the 20 mA current loop interface connector and pin assignments. The 20 mA current loop interface option can operate at a distance up to 304 meters (1000 feet).

NOTE: The VT125 terminal is designed to use either 20 mA or EIA communications. If EIA is used on a terminal that has the 20 mA option installed, the cable connecting the 20 mA option board to the terminal controller board must be disconnected.

Both the transmitter and receiver of the 20 mA interface board can be selected for active and normal (passive) operation. Usually, the terminal is connected for normal (passive) operation. Passive operation means that the terminal does not supply the 20 mA current needed during communication. The transmitter goes to the mark condition when power is turned off.

Active operation means that the terminal supplies the 20 mA current needed during communication. In an active configuration, there is no isolation and the transmitter goes to the space condition when power to the terminal is turned off.

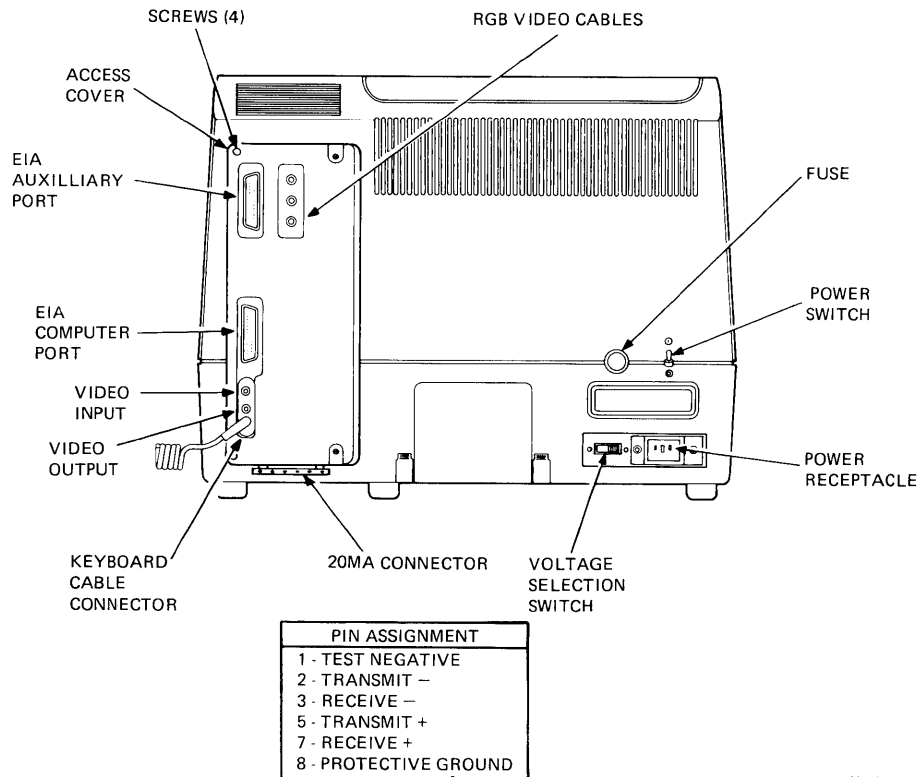

MA 6675-K

Figure 10-1 20 mA Connector and Pin Locations

## 20 MA Option Installation

The VT1XX-AA current loop option is installed using a 5 mm (3/16 in) blade screwdriver and a 2 Phillips screwdriver. Use the following procedure to install the 20 mA current loop option:

1. Turn Power switch to the off position and disconnect the power cord. See Figure 10-1.
2. Unplug the keyboard.
3. If installed, disconnect any video cables.
4. If installed, disconnect any communication cables.
5. Remove the 20 mA option board from the VT100 access cover it came in.
6. With a 2 Phillips screwdriver, remove the four screws holding the VT125 access cover in place. See Figure 10-1. Remove the access cover.
7. Install the 20 mA current loop option board onto the access cover with the three Phillips head screws provided with the option. See Figure 10-2.
8. Install the 20 mA connector to the bottom of the access cover with the two hex head screws provided with the option using a 5 mm (3/16 in) screwdriver.
9. Select TRANSMIT and RECEIVE switches for the proper configuration. See Figure 10-3.

NOTE: These switches must be selected for NORMAL (passive) operation to perform the loopback test. The loopback test verifies proper operation of the option after installation.

10. Connect the adapter cable provided with the option to the 20 mA board. See Figure 10-4. Place the access cover next to the opening in the back of the terminal and connect the other end of the cable to the connector on the terminal controller board.
11. Place the access cover into the opening of the terminal and tighten the four screws to fasten it.
12. Perform the Computer Data Port Loopback Test.

### Computer Data Port Loopback Self Test

The Computer Port Data Loopback test checks that the VT125 terminal can transmit and receive characters over the computer data port. The transmit and receive lines must be connected to each other with an external loopback connector.

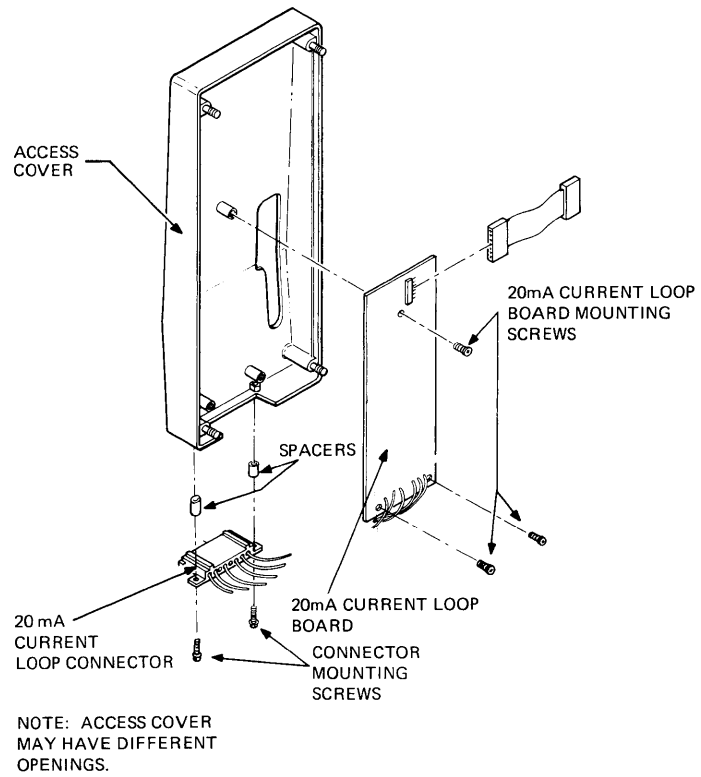

MA-5532B

Figure 10-2 20 mA Current Loop Option Board Installation

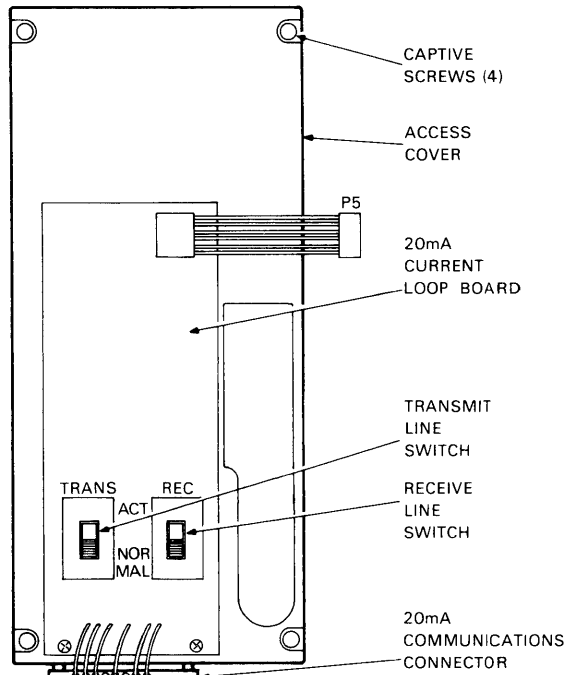

NOTE: ACCESS COVER MAY HAVE DIFFERENT OPENINGS.

MA-1996A

Figure 10-3 20 mA Current Loop Option Switches

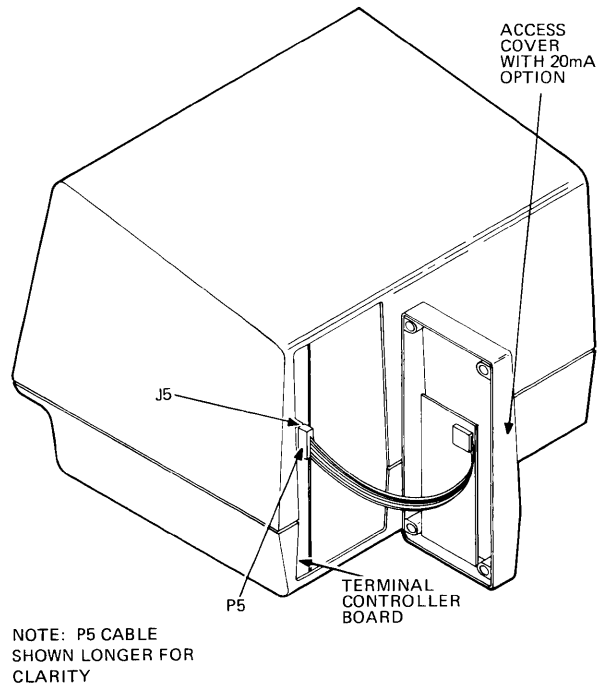

Figure 10-4 20 mA Current Loop Option Cable Position



To perform the Data Loopback Self Test, use the following procedure:

1. With the Power switch off, disconnect the communication cable and install the loopback connector (pn 70-15503-00) that was included with the option on the computer data port connector. See Figure 10-5.
2. Turn the Power switch on. The terminal performs the power up self test.
3. Be sure the terminal is ON LINE with the ANSI/VT52 SET-UP B feature selected to ANSI (SET-UP B switch 2-3 = 1). The terminal transmit and receive speeds must be the same and 300 baud or faster. Type one of the following sequences to perform the test.

ESC [ 4 ; 1 ; 2 y                      Performs the Power Up and  
Computer Data Port loopback  
self tests.

ESC [ 4 ; 1 ; 2 ; 9 y                  Performs the Power Up and  
Computer Data Port loopback  
self tests continuously until  
failure.

NOTE: The continuously running test ends only if an error is found or if power is turned off.

The test gives the following indications:

- Either the ON LINE or LOCAL indicator is turned on.
  - The Wait message is displayed on the screen and then is erased.
  - The cursor is displayed in the upper-left corner of the screen.
  - If the Computer Data Port loopback test fails, the message "VT125 EC Error" is displayed on the internal monitor.
4. Turn the Power Switch off, remove the loopback connector and connect the communication cable.

### Advanced Video Option

#### Description

The Advanced Video Option adds the following features to the text terminal capabilities of the VT125:

- 10 additional lines of 132 column display. The screen can now display a total of 24 lines in either 80- or 132- column format.

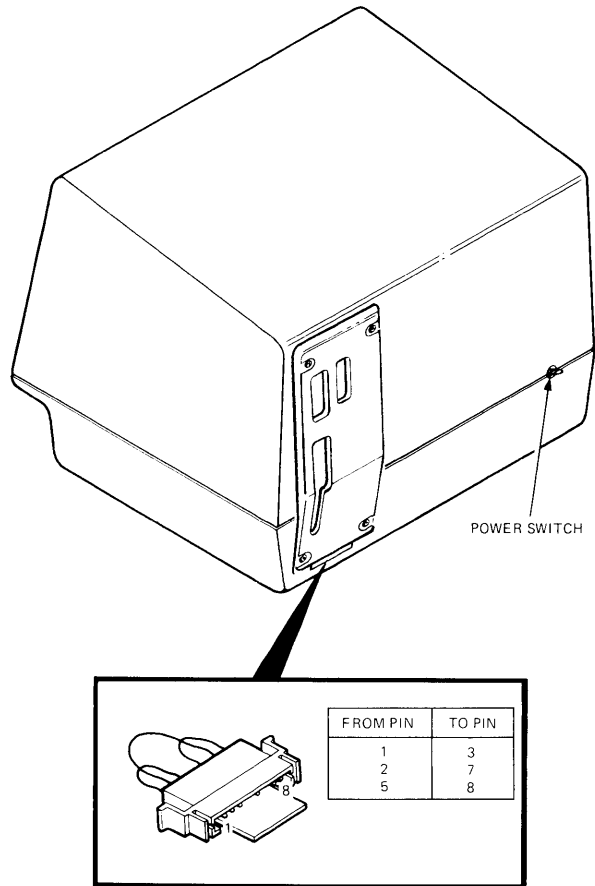

MA-7867D

Figure 10-5 20 mA Loopback Connector

- Additional character attributes - any text terminal characters can now be highlighted in any of the following ways: Bold, Blink, Underline, Reverse, any combination of the four.
- Capability to use an additional character generator ROM, for another resident character set.

### Installation

Use the following procedure to install the Advanced Video Option.

The VT1XX-AB Advanced Video option is installed using a 5 mm (3/16 in) blade screwdriver. Use the following procedure to install the option.

1. Turn Power switch to the off position and disconnect the power cord. See Figure 10-1.
2. Unplug the keyboard.
3. If installed, disconnect any video cables.
4. If installed, disconnect any communication cables.
5. With a 2 Phillips screwdriver, remove the four screws holding the access cover in place. See Figure 10-2. Remove the access cover.
6. If a 20MA current loop option is installed, disconnect the short cable from the terminal controller board. (See Figure 10-4.)
7. Remove the ground wires from the terminal controller and graphics processor boards.
8. Loosen the two large boards from their sockets, one at a time, and then pull them out together about 5 cm (2 in).
9. Remove both flat cables from the graphics processor board. See the VT100 upgrade procedure illustrations in this chapter.
10. Remove the terminal controller board from the chassis.
11. Locate the four mounting holes drilled in the terminal controller board for the AVO and mount a plastic standoff in each hole. (See Figure 10-6.)
12. Holding the Advanced Video Option board by the edges, align the AVO connector with the pins on the terminal controller board. Press the board into place.

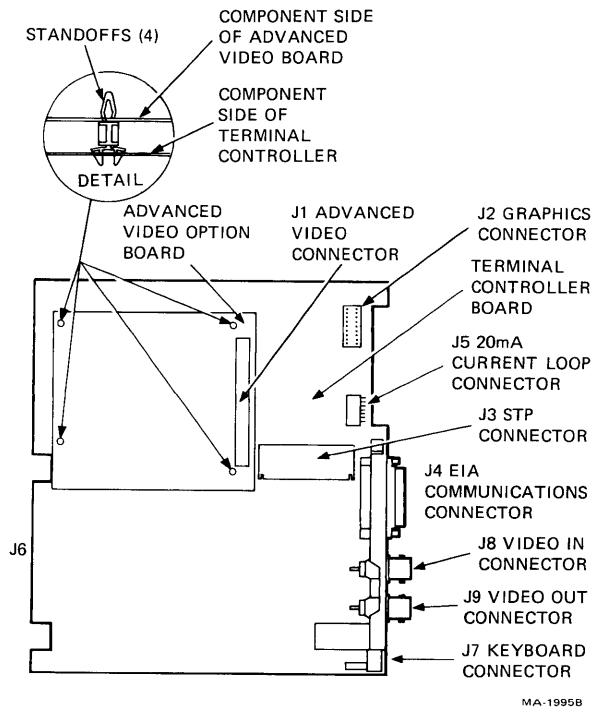

Figure 10-6 Advanced Video Option Location and Installation

13. Slide the terminal controller partially into the chassis and reconnect the two flat cables to the graphics processor board.
14. Reconnect the ground wires to the terminal controller and graphics processor boards.
15. Slide both boards into the chassis together, taking care not to stretch the cables. Seat both boards in their sockets, one at a time.
16. Place the access cover into the opening of the terminal, replacing the 20 ma adapter cable if present, and tighten the four screws.
17. Replace the power cord.
18. Perform the Advanced Video Option Test.

#### Advanced Video Option Test

Use the following procedure to check out the operation of the Advanced Video Option.

1. Turn the terminal power on and check that no error was detected during the power up self test.
2. Press the SET-UP key. The words "SET-UP A" should blink in boldface, the words "TO EXIT PRESS SET-UP" should be underlined, and the tab ruler at the bottom of the screen should have alternating normal and reverse video sections even if the cursor is selected to be underline.
3. Place the terminal in 132 - column mode and then in LOCAL.
4. Exit SET-UP and type the following sequence:

ESC < ESC # 8

The screen should now display 24 lines X 132 columns.

#### VT1XX-CB OR -CL INSTALLATION INTO VT100 AND VT105

The VT1XX-CB or -CL is a kit of all the parts needed to install a VT125 Graphics processor into a VT100 or VT105.

NOTE TO CUSTOMER: Please do not try to install this complex option. Call your DIGITAL Field Service branch for assistance.

NOTE: Before installing the Graphics Processor, check the ROMs and the etch revision level on the terminal controller board (at step 7 of this procedure). Compare the numbers of the ROMs on the board with the numbers in Figure 10-7. They should be equal or larger.

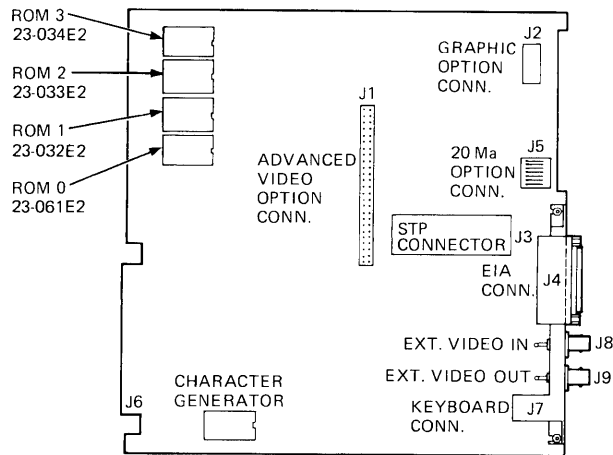

23-061 E2 NUMBER SHOULD BE 061 OR LARGER

NOTE: ROMS MAY BE  
INSTALLED IN ANY  
ORDER ON TERMINAL  
CONTROLLER BOARD.

MA-4582A

Figure 10-7 Check ROM Numbers

Check the etch number on the solder side of the board. Look for the number 5013008 followed by a letter. If the letter is D, E, etc. the board can be used. If the letter is A, B, or C, you cannot use the board.

If either of these prerequisites cannot be met, consult your Field Service branch office for information.

**1.0 TOOLS NEEDED**

1/4 inch nutdriver, 2 Phillips screwdriver, needlenosed pliers, 3/16 inch blade screwdriver.

**2.0 INSTALLATION PROCEDURE**

1. Turn off the power and disconnect the power cord.
2. Unplug the keyboard.
3. Remove the access cover (4 phillips screws or four slotted plastic screws (See Figure 10-1.) If a 20 mA current loop option is installed, disconnect the short cable from the terminal controller board. (See Figure 10-4.)
4. Remove the shipping bolts if installed (1/4 inch hex head). You can discard them.
5. Release the pop fasteners at the front and back of the terminal with a blade screwdriver and remove the top cover. (See Figure 10-8.)
6. Release the pop fasteners at the front and back of the chassis with your fingers and remove the chassis from the bottom cover.
7. Remove the terminal controller board from the chassis.
8. Remove the terminal controller edge connector by either 1. releasing the two retaining rings from the edge connector with needlenosed pliers, or 2. lifting the clips at the top and bottom of the edge connector and discarding the clips.
9. On VT100: Remove the terminal controller edge connector by either a. releasing the two retaining rings from the edge connector with needlenosed pliers, or b. lifting the clips at the top and bottom of the edge connector and discarding the clips.  
  
On VT105: Disconnect the power cable from the VT105 expansion backplane and remove the backplane. (See Figure 10-9.)
10. Install the new expansion backplane with four 12.7 mm (1/2 in) X 4-40 screws and keps nuts and four 6.4 mm (1/4 in) spacers. Install the screws at the connector

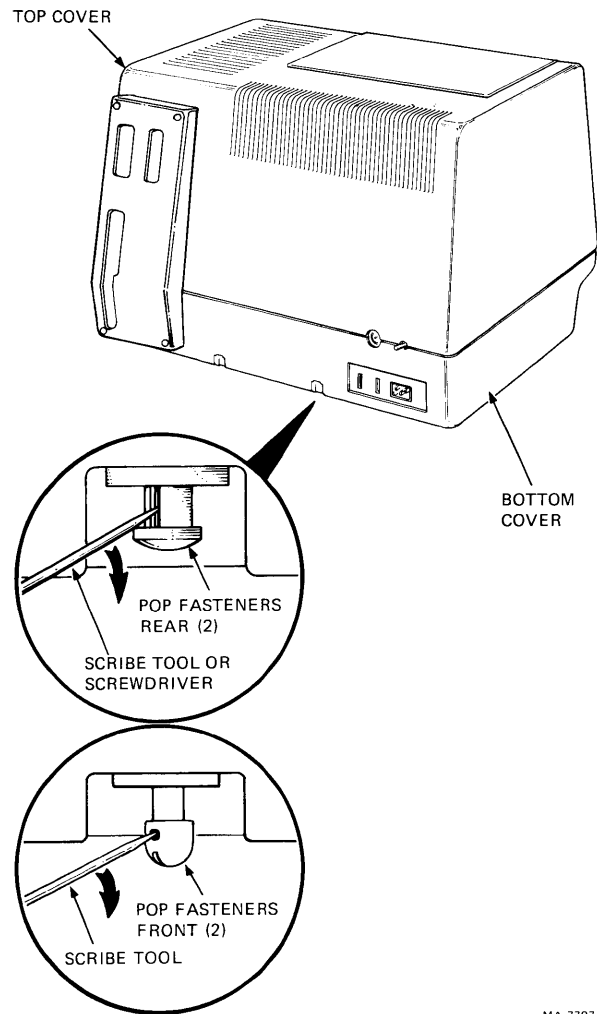

MA-7797A

Figure 10-8 Top Cover Removal



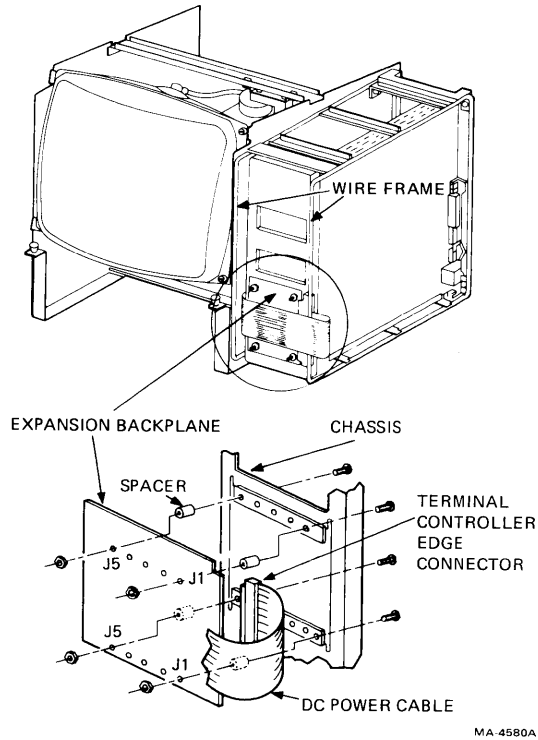

Figure 10-9 Expansion Backplane Installation

positions marked J1 and J5 on the board. (See Figure 10-9.) Be sure that the small red connector clears the inner edge of the card cage. The DC power cable must be flat against the chassis or the backplane will not fit.

11. Bend the DC power cable around so that the opening faces the CRT. Remove the alignment key in the connector opening with pliers if it is present. Install the connector onto the board edge connector, passing the cable around the wire frame if it is present. (See Figure 10-9.)

NOTE: The alignment key stays in the connector in factory-assembled VT125 terminals that comply with the FCC EMI specification.

12. Install card guides into the top and bottom of the card cage at the VT125 connector position.
13. At the fourth hole from the left on the top of the chassis (over the BNC bracket) press the ground clip with a wire onto the chassis (Figure 10-10).
14. Install the FCC RF shield (Figure 10-11): a. Loosen but do not remove two Phillips screws at the top of the shield. b. Set the chassis on end with the cage up.

NOTE: The terminal rests on several parts that stick out on the bottom. Set the terminal on a protected surface to prevent damage.

There are bumpers attached to both sides of the chassis. They protect the terminal during shipping and can be removed now if needed.

- c. Loosen but do not remove two Phillips screws at the bottom of the shield. d. Slide the shield onto the cage. e. Tighten the four Phillips screws.
15. Put the chassis into the bottom cover and press the pop fasteners to close them. Put the top cover over the terminal and press its pop fasteners to close them.
16. Slide the terminal controller board partially into the chassis.
17. Install either end of the 16 pin flat cable connector to the lower 16 pins of the terminal controller board's graphic connector (marked J2 on the terminal controller board) with the cable entering from the left. Fold the cable over the connector to the right. (See Figure 10-12.)

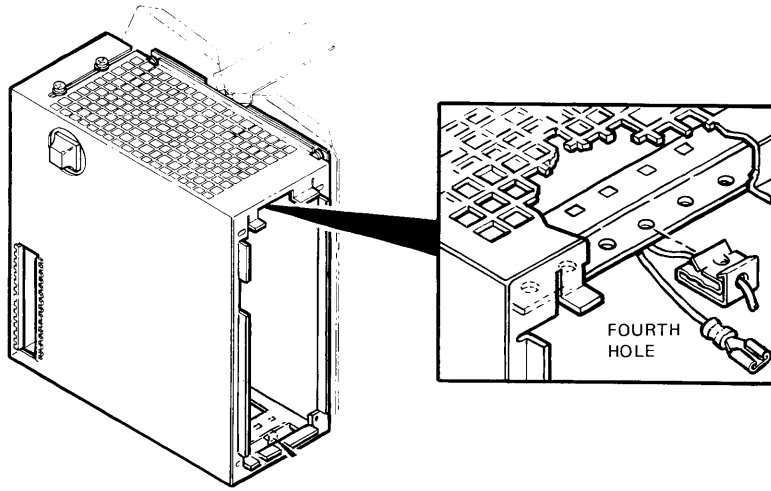

NOTE:  
INSTALL CLIPS BEFORE  
INSTALLING SHIELD.

MA 9460

Figure 10-10 Installing Ground Clips

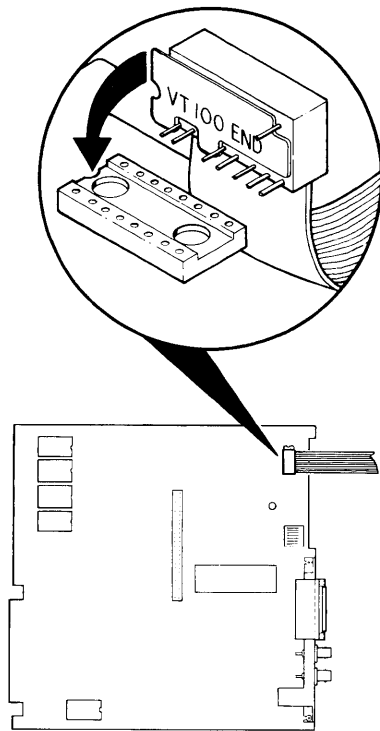

MA-9343

Figure 10-11 16 Pin Flat Cable on  
Terminal Controller

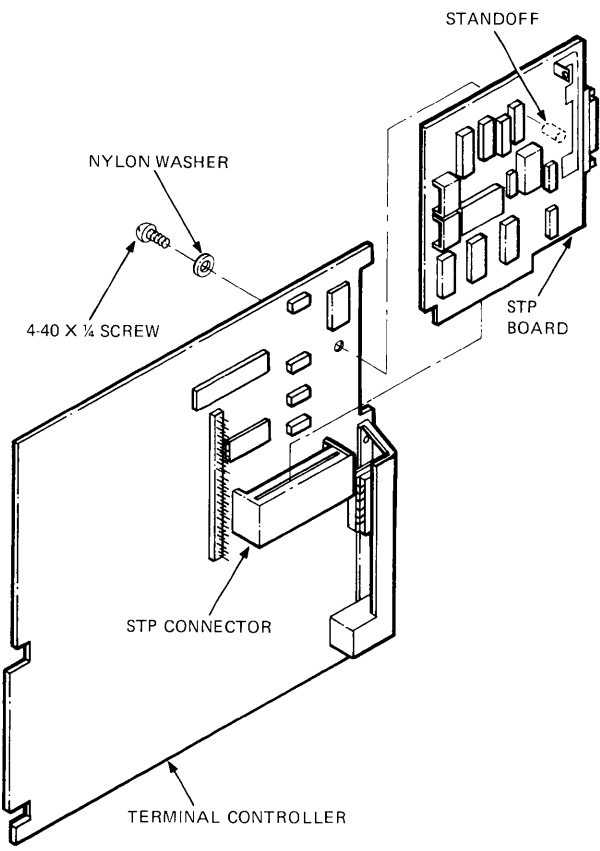

MA 9347

Figure 10-12 STP Paddleboard Installation

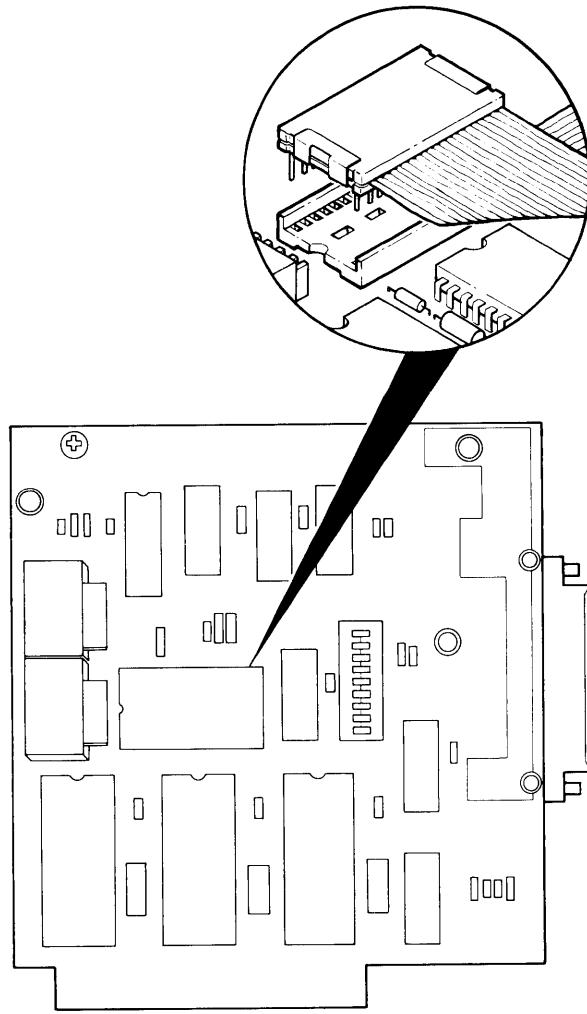

MA-9342

Figure 10-13 24 Pin Flat Cable  
on STP Board

18. Install the STP paddle board in the STP connector. Lift the 16 pin cable slightly if needed to clear the spacer when inserting the STP board. Attach it to the terminal controller board with the supplied screw and washer. (See Figure 10-13.)
19. Find the end of the 24 pin cable that has pin 1 on the cable side. The red strip should be on the left. Fold the cable under itself to the right approximately 3 centimeters (one inch) from the connector and install that end into the socket on the paddle board with the cable down. (See Figure 10-14.)
20. Install the VT125 board into the chassis so that it sticks out approximately 5 centimeters (2 inches) more than the terminal controller board.
21. Arrange the 16 pin graphic connector with the cable entering from below and install it into the connector at the top edge of the VT125 board. (See Figure 10-15.)
22. Arrange the 24 pin connector with the cable entering from the right and install it into the 24 pin socket at the right edge of the VT125 board. (See Figure 10-15.)
23. Check the switches on the STP paddle board and set switches 1,3, and 4 off, with all the other switches on. (See Figure 10-16.)
24. Connect the ground wire from the top of the chassis to the quick-connect terminal on the BNC connector bracket. See Figure 10-17.
25. Slide both boards into the chassis together, taking care not to stretch the cables. Seat both boards in their sockets, one at a time.
26. If the 20 mA adapter was installed on the VT100, remove the adapter board from the VT100 access cover and install it into the new access cover. (See procedure in this chapter.)
27. Install the 20 mA connector cable (if present) to the red connector on the terminal controller board.
28. Adjust the cables in the access opening and install the access cover, tightening the four screws carefully.
29. Perform the power up and checkout procedure that is described in Chapter 8.

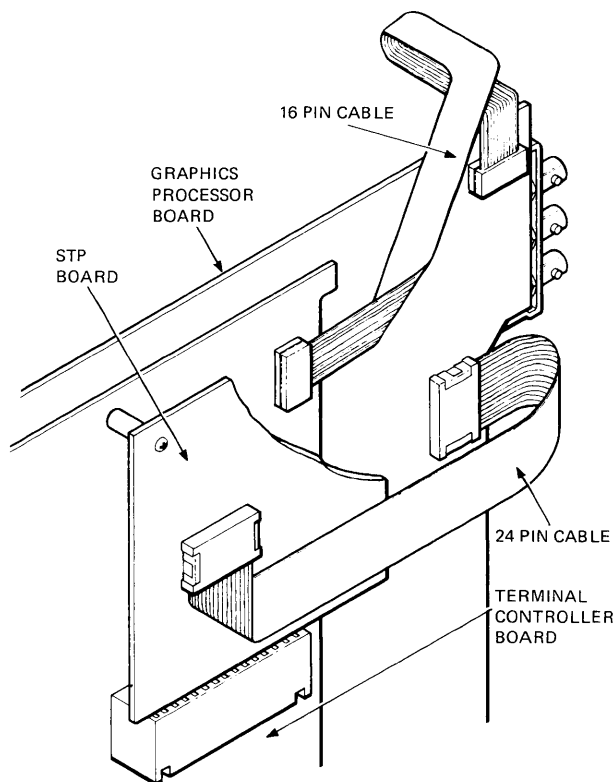

MA-9344

Figure 10-14 Graphic Cable Connections



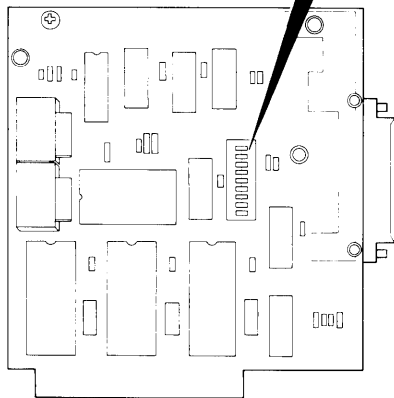
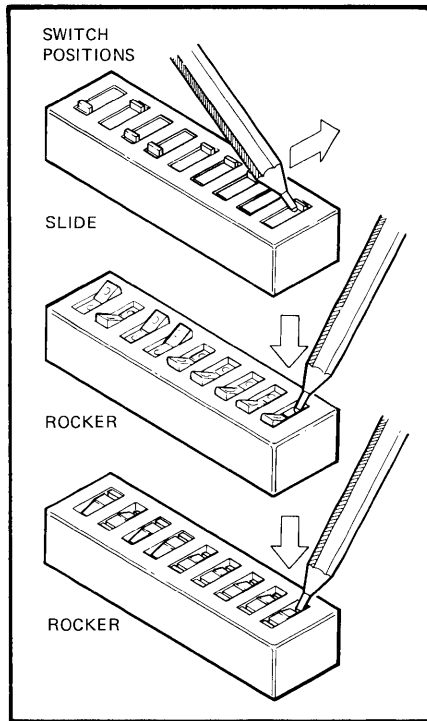

MA-7256B

Figure 10-15 Paddleboard Switches -- Variations

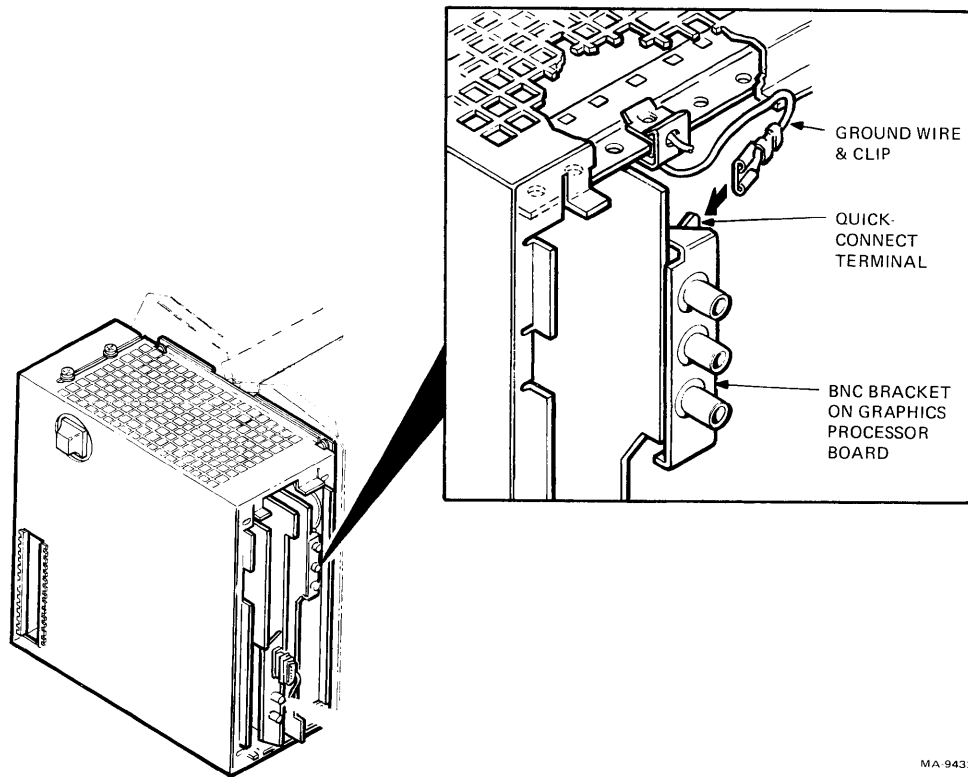
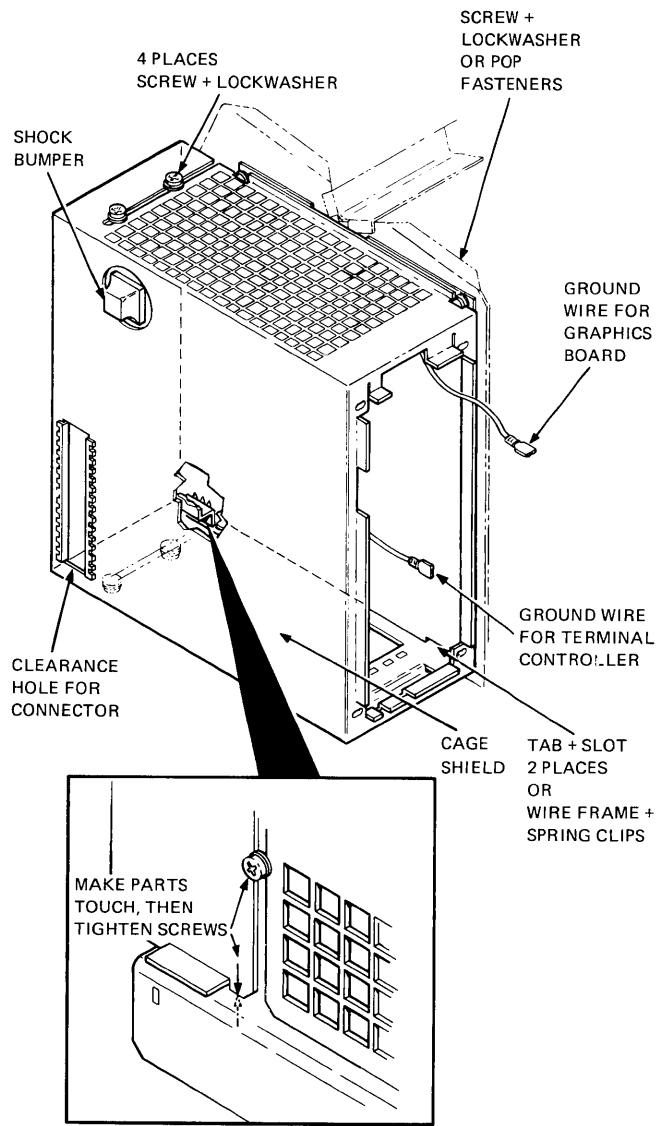

Figure 10-16 Connecting BNC Bracket Ground Wire



MA-9345

Figure 10-17 RF Shield Installed



CHAPTER 11  
ACCESSORIES AND SUPPLIES INFORMATION

GENERAL

This chapter describes the accessories and supplies offered for by DIGITAL for the VT125 terminal. Included in this chapter is a description of the accessories and supplies, their part numbers and ordering information.

ACCESSORIES AND SUPPLIES

Item No.	Part No.	Description
1	VT1XX-AE	VT125 formed screen filter, gray, anti-glare coating
1	VT1XX-AR	VT125 non-reflective filter screen
2	VT1XX-ST	VT125 terminal stand with casters
3	H9850-HK	Heavy gauge vinyl dust cover, charcoal brown.
4	H9850-DA	Anti-static floor mat, DECmat, 122 cm / 183 cm (4 ft. / 6 ft.). Driftwood color (brownish gray)
4	H9850-DB	Anti-static floor mat, DECmat, 122 cm / 183 cm (4 ft. / 6 ft.). Summer Earth color (brown/gold)
4	H9850-DC	Anti-static floor mat, DECmat, 91 cm / 305 cm (3 ft. / 10 ft.). Silver Birch color (silvergray/brown)
4	H9850-DD	Anti-static floor mat, DECmat, 91 cm / 305 cm (3 ft. / 10 ft.). Autumn Bronze color (orange/brown)
4	H9850-DE	Anti-static floor mat, DECmat, 91 cm / 305 cm (3 ft. / 10 ft.). Driftwood color (brownish gray)

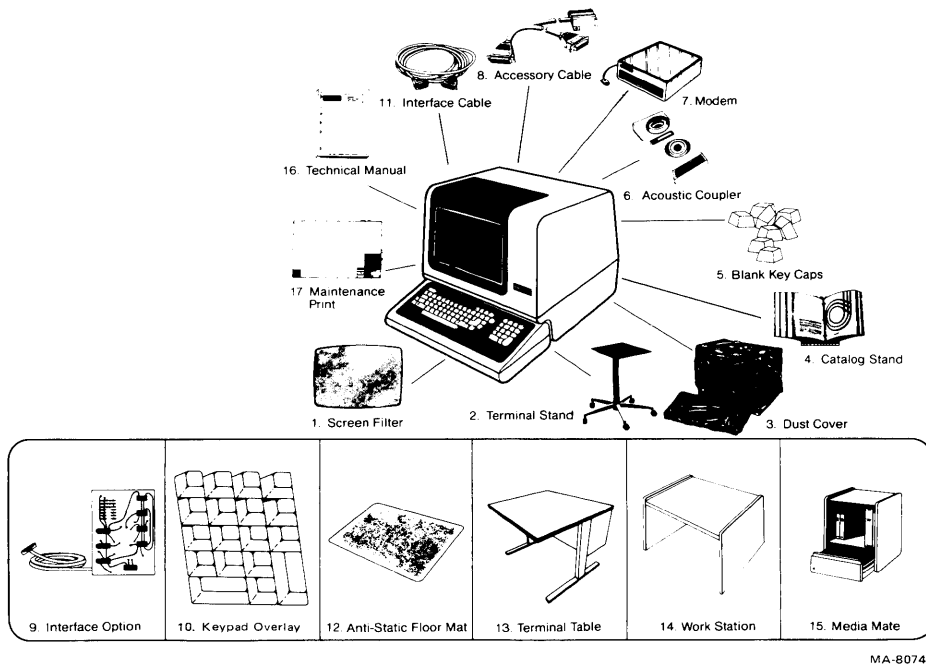

Figure 11-1 Accessories and Supplies Group

Item No.	Part No.	Description
4	H9850-DF	Anti-static floor mat, DECmat, 122 cm / 183 cm (4 ft. / 6 ft.). Silver Birch color (silvergray/brown)
4	H9850-DH	Anti-static floor mat, DECmat, 122 cm / 183 cm (4 ft. / 6 ft.). Autumn Bronze color (orange/brown)
5	H970-EB	Terminal table, 68.6 cm high / 91.4 cm wide / 76.2 cm deep (27 in. / 36 in. / 30 in.) with levelers
5	H970-HB	Terminal table, 68.6 cm high / 61.0 cm wide / 76.2 cm deep (27 in. / 24 in. / 30 in.) with levelers
6	LA12X-UA	Blank keycap kit of 50, Row 4*
6	LA12X-UB	Blank keycap kit of 50, Row 1*
6	LA12X-UC	Blank keycap kit of 50, Row 2*
6	LA12X-UD	Blank keycap kit of 50, FJ type
6	LA12X-UE	Blank keycap kit of 50, SET-UP
6	LA12X-UF	Blank keycap kit of 50, TAB
6	LA12X-UH	Blank keycap kit of 50, CAP LOCK
6	LA12X-UJ	Blank keycap kit of 50, SHIFT
6	LA12X-UL	Main array blank key cap set
6	LA12X-UM	Blank keycap kit of 50, CR
6	LA12X-UN	Blank keycap kit of 50, ENTER
6	LA12X-UP	Blank keycap kit of 50, Num Pad 0
6	LA12X-UR	Blank keycap kit of 50, Row 3*
6	LA12X-US	Blank keycap kit of 50, Row 5*
6	LA12X1-A	Acoustic telephone coupler, 300 baud
8	30-10958-02	Cable interface DF01-A couplers to VT125 terminals
9	VT1XX-AA	20 mA current loop option with BC05F-15 cable.
	VT1XX-AB	Advanced video option.

Item No.	Part No.	Description
10	BC22A-10	EIA RS232 female-female null modem cable shielded 3.0m (10 ft.)
10	BC22A-25	EIA RS232 female-female null modem cable shielded 7.6m (25 ft.)
10	BC22B-10	EIA RS232 male-female extension cable shielded 3.0m (10 ft.)
10	BC22B-25	EIA RS232 male-female extension cable shielded 7.6m (25 ft.)
10	BC23A-10	Kit of 5 BC22A-10
10	BC23A-25	Kit of 5 BC22A-25
10	BC23B-10	Kit of 5 BC22B-10
10	BC23B-25	Kit of 5 BC22B-25

NOTE: EIA RS-232-C specifies a maximum cable length of 15 m (50 ft). EIA RS-423 specifies a maximum cable length of 61 m (200 ft).

10	BC03M-A0	Female-female null modem cable 30.5m (100 ft.)
10	BC03M-B5	Female-female null modem cable 76.2m (200 ft.)
10	BC03M-E0	Female-female null modem cable 152.4m (500 ft.)
10	BC03M-L0	Female-female null modem cable 304.8m (1000 ft.)
10	BC05X-15	20 mA current loop extension cable 4.6m (15 ft.)
10	BC05X-25	20 mA current loop extension cable 7.6m (25 ft.)
10	BC05X-50	20 mA current loop extension cable 15.2m (50 ft.)
11	H9532-AA	Work-station desk with blue front panel and gray side panels, levelers, 122 cm wide / 76.2 cm high / 76.2 cm deep (48 in. / 30 in. / 30 in.)



Item No.	Part No.	Description
11	H9532-AB	Work-station desk with brown front panel and brown side panels, levelers, 122 cm wide / 76.2 cm high / 76.2 cm deep (48 in. / 30 in. / 30 in.)
12	H9850-AP	Media mate, file or shelf storage cart with casters and lockable drawer, 64.1 cm high / 38.1 cm deep / 47.0 cm wide (25.25 in. / 15 in. / 18.5 in.)

**POWER CORDS:**

17-00083-09	United States (120 V)
17-00083-10	United States (240 V)
17-00209-00	United Kingdom
17-00199-00	Continental Europe (SCHUKO)
17-00211-00	Switzerland
17-00198-00	Australia

**ALIGNMENT TEMPLATES:**

94-03220-3	Screen Alignment Template
94-03246-3A	Character Width Template
94-03246-3B	Character Height Template

**DATA LOOPBACK TEST CONNECTORS:**

12-15336-00	EIA Loopback Connector
70-15503-00	Current Loop Connector

**RELATED DIGITAL DOCUMENTATION:**

13	EK-VT125-UG	VT125 User Guide -- Describes the installation, operation and programming of the VT125 terminal. This document is shipped with the terminal.
----	-------------	--

- 13 EK-VT100-J1-003 VT100 Series Pocket Service Guide -- Describes procedures used to troubleshoot and repair the VT125 terminal to the module level (field replacable unit).
- 13 EK-VT100-TM VT100 Series Technical Manual -- Describes VT125 terminal to a detailed block level. It provides troubleshooting information for the terminal. This technical manual does not contain detailed schematic drawings. The VT125 Field Maintenance Print Set has detailed schematic drawings. The VT125 Field Maintenance Print Set is ordered separately.
- 13 EK-VT125-IP VT125 Video Terminal IPB -- Describes a detailed parts breakdown of the VT125 field replacable units. This document does not contain part numbers for components on the printed circuit boards. However, components are listed in the the VT125 Field Maintenance Print Set. The VT125 Field Maintenance Print Set is ordered separately.
- 13 EK-VT125-RC VT125 Terminal Programming Reference Card -- Provides a summary of the VT125 ReGIS escape and control sequences on a pocket size reference card.
- 14 MP-01053-00 VT125 Field Maintenance Print Set -- Provides a complete set of electrical and mechanical schematic diagrams for the VT125 terminal.
- 14 MP-01052-00 VT1XX-CB and -CL Field Maintenance Print Set -- Provides a complete set of electrical and mechanical schematic diagrams for the VT125 terminal.

**SPARES KIT:**

- 4A-VT125-00 VT125 Spares Kit

**ORDERING INFORMATION**

Continental USA

Call 800-258-1720 or mail order to:

Digital Equipment Corporation  
P.O. Box CS2008  
Nashua, NH 03061

New Hampshire

Call 602-884-6660 or mail order to:

Digital Equipment Corporation  
P.O. Box CS2008  
Nashua, NH 03061

Alaska or Hawaii

Call 408-734-4915 or mail order to:  
Digital Equipment Corporation  
632 Caribbean Drive  
Sunnyvale, CA 94086

Canada

Call 800-267-6146 or mail order to:

Digital Equipment Corporation  
P.O. Box 13000  
Kanata, Ontario  
Canada K2K 2A6  
Att: ASG Business Manager  
Telex: 610-562-8732



**APPENDIX A**  
**VT125 SPECIFICATIONS**

**GENERAL**

This appendix lists the specifications of the VT125 terminal and provides X-ray emission statements, loopback connector wiring, and a list of related documentation not provided by DIGITAL.

**VT125 SPECIFICATIONS**

**Dimensions**

Monitor	Height: 36.83 cm (14.5 inch) Width: 45.72 cm (18 inch) Depth: 36.20 cm (14.25 inch)
Keyboard	Height: 8.89 cm (3.5 inch) Width: 45.72 cm (18 inch) Depth: 20.32 cm (8 inch) Minimum table depth: 51.4 cm (20.25 inch)

**Weight**

Monitor	14.6 kg (32.2 lbs)
Keyboard	2.0 kg (4.5 lbs)
Shipping Weight	19.6 kg (43.2 lbs)

**Environment**

Operating	Temperature: 10° to 40° C (50° to 104° F) Relative Humidity: 10% to 90% Max wet bulb: 28° C (82° F) Min dew point: 2° C (36° F) Altitude: 2.4 Km (8,000 ft)
-----------	--

**Non-Operating**

Temperature: -40° to 66° C (-40° to 151° F) Relative Humidity: 0 to 95% Altitude: 9.1 km (30,000 ft)
---

**Power**

Line Voltage	99--128 V RMS single phase, 2 wire 198--256 V RMS single phase, 2 wire (selected by switch)
--------------	---

Line Frequency	47 Hz--63 Hz
Current	2.20 A RMS maximum at 120 V RMS 1.10 A RMS maximum at 240 V RMS
Input Power	150 W RMS or 250 VA apparent
Current limiting	3.0 A fast blow fuse
Power cord	Detachable, 3-conductor grounded
Power cord receptacle	EIA specified CEE22-6A
Display CRT	12 inch diagonal measure, P4 phosphor
Format	24 lines X 80 characters or 14 lines X 132 characters (selected from keyboard or computer) (24 X 132 with Advanced Video Option)
Character	7 X 10 dot matrix with descenders
Character size	80-column mode 3.35 mm X 2.0 mm (0.132 inch X 0.078 inch) 132-column mode 3.35 mm X 1.3 mm (0.132 inch X 0.051 inch)
Active Display Size	202 mm X 115 mm (8 inch X 4.5 inch)
Character Set	ASCII and UK displays 96 characters (with upper- and lowercase, numeric and punctuation), 32-character special graphics set
Cursor type	Blinking block character or blinking underline (selected from keyboard)
Keyboard General	83-key detachable unit with a 1.9 m (6 ft) coiled cord attached
Key Layout	65-keys arranged similar to standard typewriter with 18-key auxiliary keypad.
Auxiliary Keyboard	18 keys with period, comma, minus, enter, and four general purpose function keys
Visual Indicators	Seven: ON LINE, LOCAL, KBD LOCKED, and four programmable.
Audible Indicators	Audible keyclick for each keystroke (selectable from keyboard)

Bell: sounds when BEL character received, and 2) sounds eight characters from right margin (selected from keyboard)

Multiple bell sounds on error in SET-UP save or recall operation

Communication  
Type

Full Duplex EIA

Speeds

50, 75, 110 (two stop bits), 134.5, 150, 200, 300, 600, 1200, 1800, 2000, 2400, 3600, 4800, 9600, 19,200 baud (selected from keyboard)

Code

ASCII (ISO 646 and CCITT Alphabet 5)

Character format

Asynchronous

Character size

7 or 8 bits (selected from keyboard)

Parity

Even, odd or none (selected from keyboard)

Buffer overflow  
prevention

Automatic generation of XON and XOFF control codes. The VT125 Graphics Terminal requires XON/XOFF support in its host computer

Composite Video  
Output (J9)

The composite video output provides RS170 output with the following nominal characteristics (Figure A-1).

Output impedance = 75 ohms, dc coupled  
SYNC level = 0V

Black level = approximately 0.3 V when loaded with 75 ohms

White level = approximately 1.0 V with a 75 ohm load

Composite sync waveform meets EIA RS170 standards.

Vertical interval is six equalizing pulses, six vertical sync pulses, and six more equalizing pulses. Timing is as follows:

Equalizing pulse width

2.33 us  $\pm$ 50 ns

Vertical pulse width

27.28 us  $\pm$ 200 ns

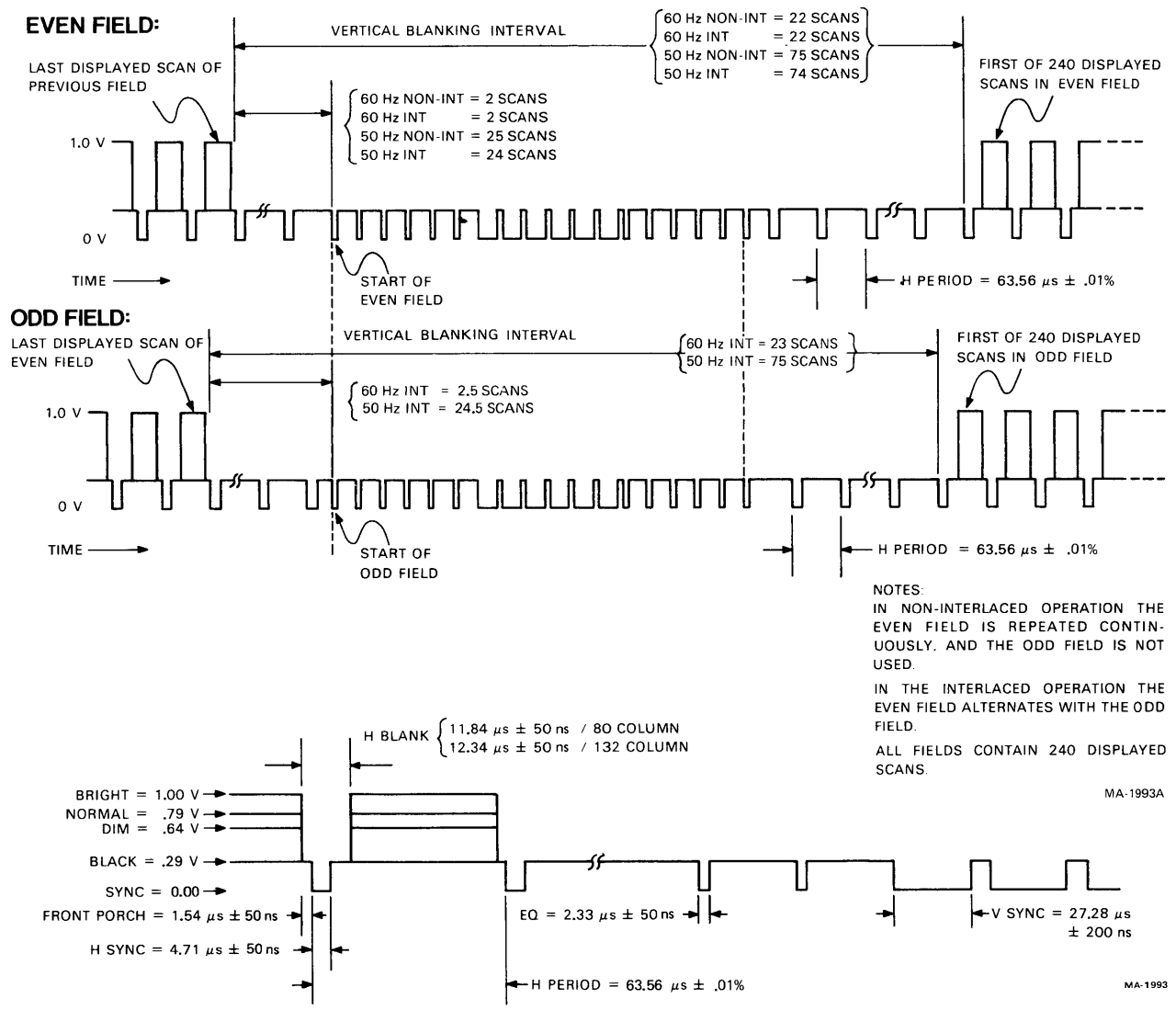

Figure A-1 Composite Video Output



Horizontal pulse width  
4.71 us +50 ns  
Horizontal blank width  
11.84 us +50 ns/80 column mode  
12.34 us +50 ns/132 column mode  
Front Porch  
1.54 us +50 ns

### Color Video Outputs

Each of the color outputs is a DC coupled analog signal with an output impedance of 75 ohms and a level ranging from 0 to 1 volt when loaded with 75 ohms. No sync is available on the color outputs.

### Video Input

An analog signal applied to the video input will be "ORed" with the internal video signal so the beam intensity at any point on the screen will correspond to the intensity of that signal which would tend to make the beam brighter at that point. A video signal on this input affects only the internal screen and does not appear on the composite video output. This input has the following nominal characteristics:

1. Input impedance = 75 ohms, dc-coupled
2. Black level = 0 V
3. White level = 1.0 V
4. Maximum continuous input = +-2.0 V

The external video source must be synchronized to the VT125; it may do this by referencing the composite sync on the composite video output. This means that the VT125 video input will not synchronize with any composite video source.

### X-RAY Emission Data

Rated anode voltage: 12 kV (fixed)  
Dose rate: Less than 1.43 pA/kg (20 uR/h)\*  
Compliance with:

- Paragraph 5, clause 2 of German X-Ray ordinance (1973)
- CSA 22.2 no. 154-1975
- Paragraph 4.1.4
- VDE 0804/5.72, Paragraph 23
- VDE 0730 part 2P/6.76, Paragraph 33
- VDE 0860 part 1/11.76, Paragraph 6
- IEC 65 public 1/1972, Paragraph 6
- CSA no. 65
- UL 478
- EMCA 57

---

\* Measured at a distance of 5 cm (1/96 inch) at any accessible point from the outer surface.

Workstation exposure            Does not expose the operator to dangerous X-ray radiation

**LOOPBACK CONNECTOR WIRING**

**From            To**

EIA

Pin 2            Pins 3 and 15

Pin 4            Pins 5 and 8

Pin 20           Pins 6 and 22

Pin 19           Pins 12 and 17

20 mA

Pin 1            Pin 3

Pin 2            Pin 7

Pin 5            Pin 8

**RELATED DOCUMENTATION**

ANSI specifications can be ordered at the following address.

Sales Department  
American National Standards Institute  
1430 Broadway  
New York, N.Y. 10018

EIA specifications can be ordered at the following address.

Electronic Industries Association  
Engineering Department  
2001 Eye St. NW  
Washington, DC 20006

International standards can be ordered at the following address.

CCITT  
UN Book Store  
United Nations Building  
N.Y., N.Y. 10017

**APPENDIX B**  
**SET-UP B SUMMARY**

**GENERAL**

This appendix provides a summary of the VT125 terminal SET-UP features. Table B-1 lists the SET-UP features. Figure B-1 shows the screen displays. Figure B-2 is a summary of the SET-UP B features.

**Table B-1 SET-UP Feature Types**

SET-UP Feature	Operator Preference	Communication Compatibility	Installation
ON LINE/LOCAL		X	
Screen brightness	X		
Columns per line		X	
Tab stops		X	
Scroll	X		
Auto repeat	X		
Screen background	X		
Cursor	X		
Margin bell	X		
Keyclick	X		
ANSI/VT52		X	
Auto XON/XOFF		X	
US/UK character set			X
Auto wrap		X	
Line feed/new line		X	
Interface			X
Parity sense		X	
Parity		X	
Bits per character		X	
Power			X
AUX port bits per character		X	
AUX port speed		X	
Transmit speed		X	
Receive speed		X	
Answerback		X	

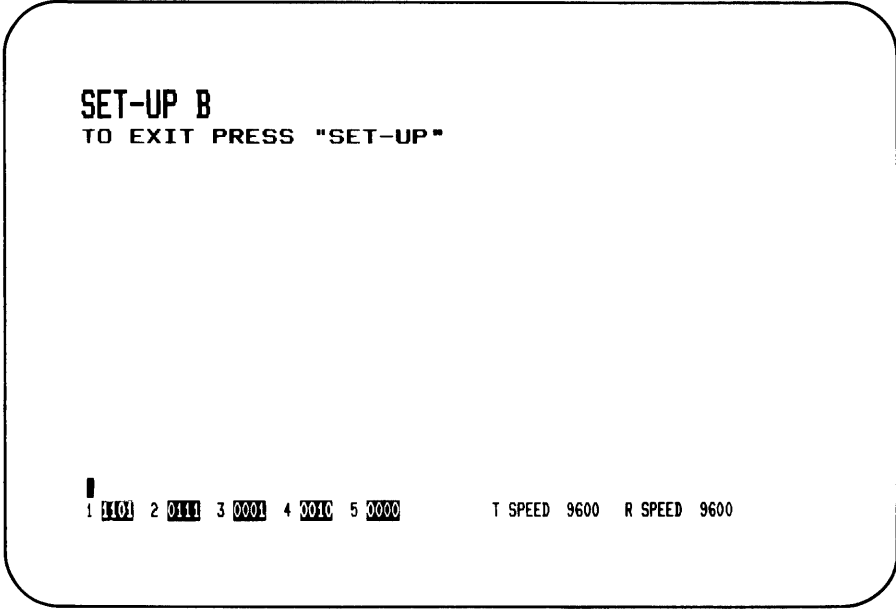
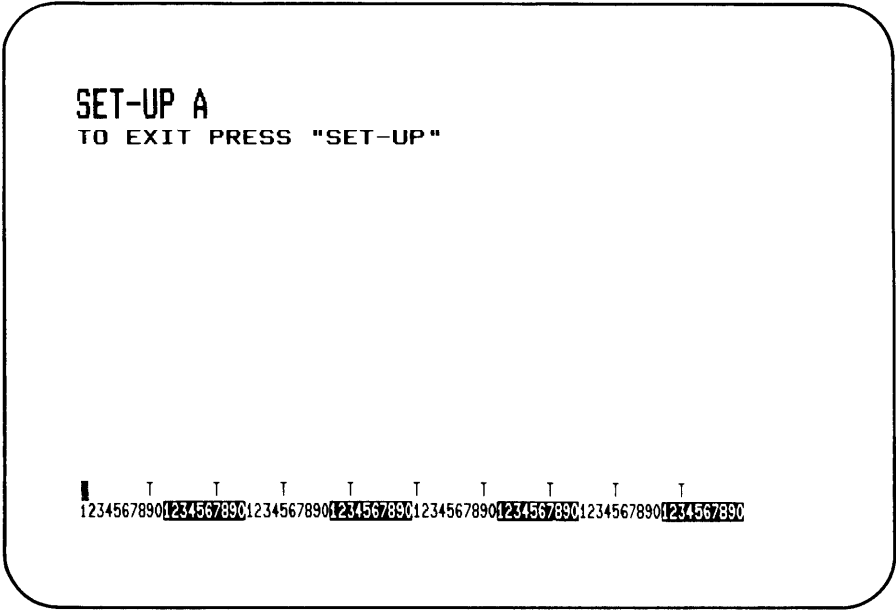

MA 9480

Figure B-1 SET-UP B Display

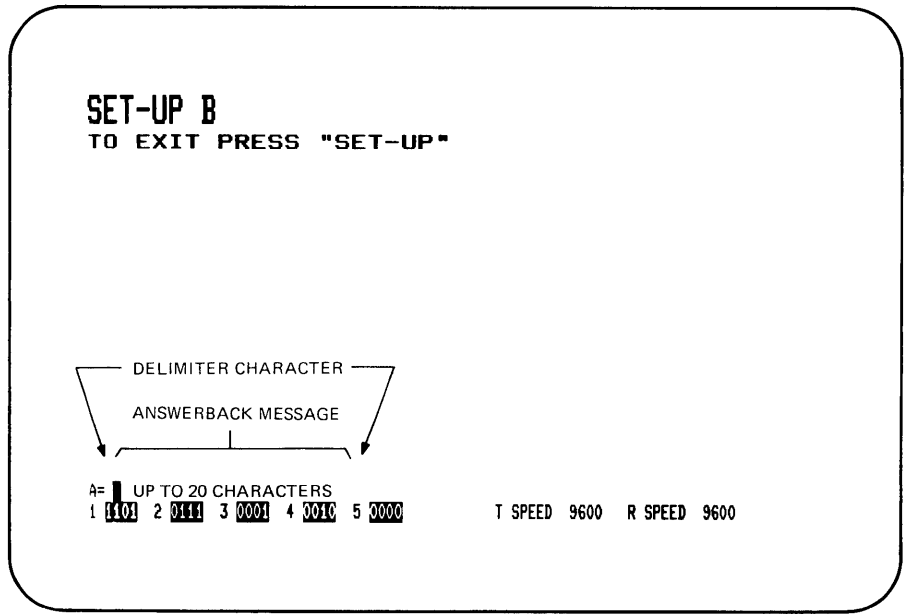

MA-9479

Figure B-2 SET-UP B Summary



# FUNCTION KEYS

Figure C-2 shows the control codes generated by the function keys. For the shaded keys, CTRL does not need to be pressed in order to generate the control character. Table C-1 lists the control codes generated.

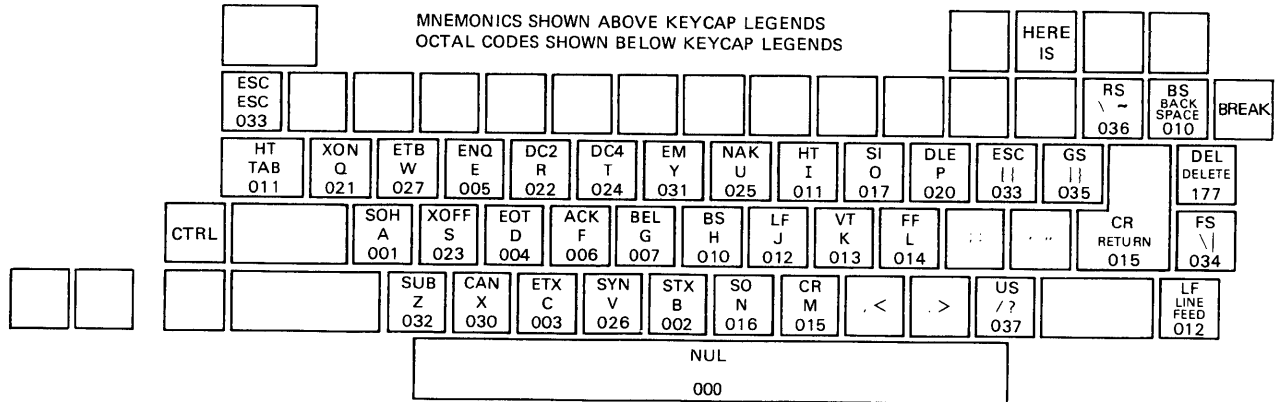

MA-7419

Figure C-2 Function Key Control Codes



**Table C-1 Control Codes Generated**

Control Character	Character Mnemonic	Code (Octal) Sent	Key Pressed with CTRL	Dedicated Key
Null	NUL	000	Space Bar	
Start of heading	SOH	001	A	
Start of text	STX	002	B	
End of text	ETX	003	C	
End of transmission	EOT	004	D	
Enquire	ENQ	005	E	
Acknowledge	ACK	006	F	
Bell	BEL	007	G	
Backspace	BS	010	H	BACK SPACE
Horizontal Tabulation	HT	011	I	TAB
Line feed	LF	012	J	LINE FEED
Vertical tab	VT	013	K	
Form feed	FF	014	L	
Carriage return	CR	015	M	RETURN (ENT)
Carriage return Line feed	CR LF	015 012		RETURN (ENT)
Shift out	SO	016	N	
Shift in	SI	017	O	
Data Link Escape	DLE	020	P	
Device control 1	DC1 (XON)	021	Q	
Device control 2	DC2	022	R	
Device control 3	DC3 (XOFF)	023	S	
Device control 4	DC4	024	T	
Negative acknowledge	NAK	025	U	
Synchronous idle	SYN	026	V	
End of transmission Block	ETB	027	W	
Cancel previous word or character	CAN	030	X	
End of medium	EM	031	Y	
Substitute	SUB	032	Z	
Escape	ESC	033	[	
File separator	FS	034	\	
Group separator	GS	035	]	
Record separator	RS	036	~	
Unit separator	US	037	?	
Delete	DEL	177		DELETE

\* The RETURN character code can be changed by the line feed/new line feature. When off, this feature causes RETURN to generate a single control character (CR). When on, this feature causes RETURN to generate two characters (CR, LF). Also, depending on the keypad mode selected, RETURN and ENTER may generate the same control codes.



APPENDIX D  
PROGRAMMING SUMMARY

**GENERAL**

This appendix provides a summary of the VT125 escape and control sequences.

**CONTROL CHARACTERS**

Name	Character Mnemonic	Octal Code	Function
Null	NUL	000	Ignored when received (not stored in input buffer, used as a fill character.
Enquire	ENQ	005	Transmits answerback message.
Bell	BEL	007	Generates a bell tone.
Backspace	BS	010	Moves cursor to the left one character position, unless it is at the left margin, in which case no action occurs.
Horizontal Tab	HT	011	Moves cursor to the next tab stop, or to the right margin if there are no more tab stops.
Line Feed	LF	012	Causes a line feed or a new line operation. (Refer to line feed/new line mode.)
Vertical Tab	VT	013	Processed as LF.
Form Feed	FF	014	Processed as LF.
Carriage Return	CR	015	Moves cursor to left margin on the current line.
Shift Out	SO	016	Selects G1 character set, as designated by a select character set sequence.

Name	Character Mnemonic	Octal Code	Function
Shift In	SI	017	Selects G0 character set, as designated by a select character set sequence.
Device Control 1	DC1	021	Processed as XON. Causes transmitting characters.
Device Control 3	DC3	023	Processed as XOFF. Causes terminal to stop transmitting all characters except XOFF and XON.
Cancel	CAN	030	If received during an escape or control sequence, sequence is cancelled and the substitution character (⌘) is displayed.
Substitute	SUB	032	Processed as CAN.
Escape	ESC	033	Processed as a sequence introducer.
Delete	DEL	177	Ignored when received (not stored in input buffer).

#### ANSI COMPATIBLE SEQUENCES

Set Mode Name	Mnemonic	Mode	Sequence
Line feed/new line	LMN	New line	ESC [20h
Cursor key	DECCKM	Application	ESC [?1h
ANSI/VT52	DECANM	ANSI	N/A
Column	DECCOLM	132 column	ESC [?3h
Scrolling	DECSCLM	Smooth	ESC [?4h
Screen	DECSCNM	Reverse	ESC [?5h
Origin	DECOM	Relative	ESC [?6h
Auto wrap	DECAWM	On	ESC [?7h
Auto repeat	DECARM	On	ESC [?8h
Interlace	DECINLM	On	ESC [?9h

## Reset Mode

Name	Mnemonic	Mode	Sequence
Line feed/new line	LMN	Line feed	ESC [201*
Cursor key	DECCKM	Cursor	ESC [?11*
ANSI/VT52	DECANM	VT52	ESC [?21*
Column	DECCOLM	80 column	ESC [?31*
Scrolling	DECSCLM	Jump	ESC [?41*
Screen	DECSCNM	Normal	ESC [?51*
Origin	DECOM	Absolute	ESC [?61*
Auto wrap	DECAWM	Off	ESC [?71*
Auto repeat	DECARM	Off	ESC [?81*
Interlace	DECINLM	Off	ESC [?91*

|  
\* The last character of the sequence is lowercase L (154<sub>8</sub>).  
|

## Cursor Key Codes Generated

Cursor	ANSI Characters Generated	
	Reset (Cursor)	Set (Application)
Up	ESC [ A	ESC O A
Down	ESC [ B	ESC O B
right	ESC [ C	ESC O C
left	ESC [ D	ESC O D

## Keypad Character Selection

Name	Mnemonic	Sequence
Alternate	DECKPAM	ESC =
Numeric	DECKPNM	ESC >

## Auxiliary Keypad Codes Generated

Key	VT52 Alternate Keypad Mode Off (Numeric Mode)	VT52 Alternate Keypad Mode On	ANSI Numeric Keypad Mode	ANSI Alternate Keypad Mode
Ø	Ø	ESC ? p	Ø	ESC O p
1	1	ESC ? q	1	ESC O q
2	2	ESC ? r	2	ESC O r
3	3	ESC ? s	3	ESC O s
4	4	ESC ? t	4	ESC O t
5	5	ESC ? u	5	ESC O u
6	6	ESC ? v	6	ESC O v
7	7	ESC ? w	7	ESC O w
8	8	ESC ? x	8	ESC O x
9	9	ESC ? y	9	ESC O y
- (minus)	- (minus)	ESC ? m	- (minus)	ESC O m
, (comma)	, (comma)	ESC ? l *	, (comma)	ESC O l *
. (period)	. (period)	ESC ? n	. (period)	ESC O n
ENTER	Same as RETURN	ESC ? M	Same as RETURN	ESC O M
PF1	ESC P	ESC P	ESC O P	ESC O P
PF2	ESC Q	ESC Q	ESC O Q	ESC O Q
PF3	ESC R	ESC R	ESC O R	ESC O R
PF4	ESC S	ESC S	ESC O S	ESC O S

|  
\* The last character of the sequence is lower case L (154<sub>8</sub>).  
|

### Select Character Sets (SCS)

Character Set	GØ Designator	G1 Designator
United Kingdom (UK)	ESC ( A	ESC ) A
United States (USASCII)	ESC ( B	ESC ) B
Special characters and line drawing set	ESC ( Ø	ESC ) Ø
Alternate character ROM standard set	ESC ( 1	ESC ) 1
Alternate character ROM special	ESC ( 2	ESC ) 2

Name	Mnemonic	Sequence
Single Shift 2	SS2	ESC N
Single Shift 3	SS3	ESC O

NOTE: The following control characters are generated differently from previous DIGITAL terminals.

VT125		Previous Terminal Keys
Code	Keys	
NUL	CTRL -- Space bar	CTRL -- @
RS	CTRL -- ~	CTRL -- ^
US	CTRL -- ?	CTRL -- _

### Character Attributes

Name	Mnemonic	Sequence	Meaning
Select Graphic Rendition	SGR	ESC [ 0 m	Attributes off
Select Graphic Rendition	SGR	ESC [ 1 m	Bold or increased intensity
Select Graphic Rendition	SGR	ESC [ 4 m	Underline
Select Graphic Rendition	SGR	ESC [ 5 m	Blink
select Graphic Rendition	SGR	ESC [ 7 m	Negative (reverse) image

All other parameter values are ignored.

Without the Advanced Video Option, a character can have only one attribute, and the attribute can only be underline or reverse. Either 4 or 7 can be used in the control sequence, but the VT125 interprets the parameter as whichever attribute has been selected for the cursor in SET-UP. (See cursor selection in the SET-UP chapter.)

### Scrolling Region

Name	Mnemonic	Sequence
Set top and bottom margins	DECSTBM	ESC [ Pt; Pb r

## Cursor Movement commands

Name	Mnemonic	Sequence
Cursor up	CUU	ESC [ Pn A
Cursor down	CUD	ESC [ Pn B
Cursor forward (right)	CUF	ESC [ Pn C
Cursor backward (left)	CUB	ESC [ Pn D
Cursor position	CUP	ESC [ Pn; Pc H
Cursor position (home)	CUP	ESC [ H
Horizontal and vertical position	HVP	ESC [ Pl; Pc f
Horizontal and vertical position (home)	HVP	ESC [ f
Index	IND	ESC D
Reverse index	RI	ESC M
Next line	NEL	ESC E
Save cursor (and attributes)	DECSC	ESC 7
Restore cursor (and attributes)	DECRC	ESC 8

## Tab Stops

Name	Mnemonic	Sequence
Horizontal tab set (at current column)	HTS	ESC H
Tabulation clear (at current column)	TBC	ESC [ g
Tabulation clear (at current column)	TBC	ESC [ 0 g
Tabulation clear (all tabs)	TBC	ESC [ 3 g

## Line Attributes

Name	Mnemonic	Sequence
Double-height top half	DECDDL	ESC # 3
Double-height bottom half	DECDDL	ESC # 4
Single-width single-height	DECSWL	ESC # 5
Double-width single-height	DECDDL	ESC # 6



## Erasing

Name	Mnemonic	Sequence
Erase in line (cursor to end of line)	EL	ESC [ K
Erase in line (cursor to end of line)	EL	ESC [ 0 K
Erase in line (beginning of line to cursor)	EL	ESC [ 1 K
Erase in line (entire line containing cursor)	EL	ESC [ 2 K
Erase in display (cursor to end of screen)	EK	ESC [ J
Erase in display (cursor to end of screen)	ED	ESC [ 0 J
Erase in display (beginning of screen to cursor)	ED	ESC [ 1 J
Erase in display (entire screen)	ED	ESC [ 2 J

## Reports

Name	Mnemonic	Sequence
Device status report (request status of VT125) Response:	DSR	ESC [5n
Terminal OK	DSR	ESC [0n
Terminal not OK	DSR	ESC [3n
Device status report (request cursor position)	DSR	ESC [6n
Report cursor position	CPR	ESC [P1; Pc R
Device attributes (what are you)	DA	ESC [c
Device attributes (what are you)	DA	ESC [0c
Identify terminal (what are you)	DECID	ESC z
Device attributes Response: VT125	DA	ESC [?12; <VT100 feature <VT125 features>; <VT125 ROM version>c <VT100> 5 = No AVO 7 = AVO <VT125> 1 = Printer 0 = No Printer

## Reset

Name	Mnemonic	Sequence
Reset to initial state	RIS	ESC c

## Test and Adjustments

Name	Mnemonic	Sequence
------	----------	----------

Screen alignment display (fill screen with "Es")	DECALN	ESC # 8
---	--------	---------

Invoke confidence test (power-up test)	DECTST	ESC [ 4 ; 1 y
---	--------	---------------

VT125 Self-test Format: ESC [ 4 ; 1 ; Ps . . . ; Ps y

Ps = 1	VT125 Power up test
--------	---------------------

Ps = 2	VT125 Computer Port Data loopback test
--------	---

Ps = 3	VT125 Auxiliary Port Data loopback test
--------	--

Ps = 4	VT125 Display test
--------	--------------------

Ps = 5	VT125 Video Bit Map Memory test
--------	------------------------------------

Ps = 9	Repeat any selected tests continuously until power off or failure
--------	---

## Keyboard LEDs (Indicators)

Name	Mnemonic	Sequence
Load LEDs (all off)	DECLL	ESC [ q
Load LEDs (L1 on)	DECLL	ESC [ 1 q
Load LEDs (L2 on)	DECLL	ESC [ 2 q
Load LEDs (L3 on)	DECLL	ESC [ 3 q
Load LEDs (L4 on)	DECLL	ESC [ 4 q

## VT52 COMPATIBLE MODE

### Set and Reset Modes                      Sequence

Enter ANSI mode                      ESC <

### Keypad Character Selection

#### Name                                      Sequence

Enter alternate keypad mode            ESC =  
Exit alternate keypad mode            ESC >

### Character Sets

#### Name                                      Sequence

Special graphics character set\*        ESC F  
Select US/UK character set            ESC G  
(as determined by US/UK  
character SET-UP feature)

### Cursor Position

#### Name                                      Sequence

Cursor up†                              ESC A  
Cursor down†                            ESC B  
Cursor right†                            ESC C  
Cursor left†                             ESC D  
Cursor to home                          ESC H  
Direct cursor address‡                ESC Y Pl Pc  
Reverse line feed                      ESC I

### Erasing

#### Name                                      Sequence

Erase to end of line                    ESC K  
Erase to end of screen                ESC J

### Reports

#### Name                                      Sequence

Identify (what are you)                ESC Z  
    Response: VT100                    ESC / Z

|

\* Same as special character and line drawing set in ANSI mode.

† Same when sent from the terminal.

‡ Line and column numbers for direct cursor address are single character codes whose values are the desired number plus 31<sub>(10)</sub>. Line and column numbers start at one.

## ReGIS Command Summary

```
P { [] } Reset pattern memory
  { [<position>] } Move to <position>
  { <pixel vector> or <pv> } Move <multiplier> pixels
  { } in <pv> direction
  { (B) } Save current location
  { (S) } Save dummy location
  { (E) } Move to last saved location
  { (W(<temporary writing controls>)) } P(W(M<multiplier>))
```

## Position Command Summary

```
V { [] } Draw dot at current position
  { [<position>] } Draw vector to <position>
  { <pixel vector> or <pv> } Draw <multiplier> pixels
  { } in <pv> direction
  { (B) } Save current position
  { (S) } Save dummy position
  { (E) } Draw to last saved position
  { (W(<temporary writing controls>)) } V(W(M<multiplier>))
```

## Vector Command Summary

C	{	[<position>]	}	Circle with Center at Curr
	{		}	Position, Circumference at
	{		}	<position>
	{	(C)<position>]	}	Circle with Center at
	{		}	<position>, Circumference
	{		}	at Current Position
	{	(A<degrees>) [position>]	}	Arc with Center at Current
	{		}	Position, starting at
	{		}	<position> for <degrees>
	{	(A<degrees>C) [position>]	}	Arc with Center at
	{		}	<position>, starting at
	{		}	current position for
	{		}	<degrees>
	{	(B) [position] . . . [position] (E)	}	Bounded (closed) curve
	{	(S) [] [position] . . . [position] [] (E)	}	Unbounded (open) curve
	{	(W(temporary writing controls))	}	

#### Curve Command Summary

T	{	(S <size number>)	}
	{	(H <height>)	}
	{	[<spacing>]	}
	{	(S [<width in pixels>, <height in pixels>])	}
	{	(M [<width pixel multiplier>, <height pixel multiplier>])	}
	{	(D <direction angle>)	}
	{	(D <string tilt> S <size> D <char tilt>)	}
	{	(T <italic degrees>)	}
	{	(A <pattern set number>)	}
	{	((B) <temporary attributes block> (E))	}
	{	(W(temporary writing controls))	}

#### Text Command Summary

W { (C)	}	Complement
{ (E)	}	Erase
{ (R)	}	Replace
{ (V)	}	Overlay
{ }	}	
{ (F <foreground planes>)	}	∅ = no planes
{ }	}	1 = plane 1
{ }	}	2 = plane 2
{ }	}	3 = planes 1 and 2
{ }	}	
{ (I ∅ or (D) )	}	Foreground
{ 1 (R) )	}	Intensity:
{ 2 (G) )	}	Dark or Dark
{ 3 (B) )	}	Dim grey Red
{ (C) )	}	Light grey Green
{ (Y) )	}	White Blue
{ (M) )	}	Cyan
{ (W) )	}	Yellow
{ }	}	Magenta
{ }	}	White
{ or	}	
{ (I (H <hue angle>	}	
{ L <lightness percent>	}	
{ S <saturation percent>))	}	
{ }	}	
{ (M <multiplier>)	}	
{ }	}	
{ (N 1)	}	= negative on
{ (N ∅)	}	= negative off
{ }	}	
{ (S 1)	}	= shading on
{ (S ∅)	}	= shading off
{ (S [,shading reference])	}	
{ (S 'shading character')	}	
{ }	}	
{ (P <binary pattern>)	}	Enter pattern
{ (P <pattern number>)	}	Use VT125 pattern
{ (P (M <pattern multiplier>))	}	
{ }	}	
{ (W<i>(P<j>,N<k>))	}	Custom writing control

### Writing Controls Summary

S {	<pixel vector>	}	Scroll
{	[position]	}	
{	(A [<position>] [<position>])	}	Display
{		}	addressing
{	(E)	}	Erase screen
{	(H [<position>] [<position>])	}	Hard copy (corner positions
{		}	optional)
{	(H(P[<position>]))	}	Set hard copy offset
{	(I 0 or (D) )	}	Background
{	1 (R) )	}	Intensity:
{	2 (G) )	}	Dark or Dark
{	3 (B) )	}	Dim grey Red
{	(C) )	}	Light grey Green
{	(Y) )	}	White Blue
{	(M) )	}	Cyan
{	(W) )	}	Yellow
{		}	Magenta
{		}	White
{	or	}	
{	(I (H <hue angle>	}	
{	L <lightness percent>	}	
{	S <saturation percent>))	}	
{	S(M<n> (<mono HLS>) (A<color HLS>))	}	Output
{		}	Mapping
{	(S <scale>)	}	
{	(S (X<scale>Y<scale>))	}	
{	(T <ticks>)	}	Time Delay

### Screen Controls Summary

```

@ { . } Clear all macrographs
  { }
  { :keyletter character_string @; } Define macrograph
  { }
  { keyletter } Invoke macrograph

```

#### Macrograph Command Summary

```

L { (A<integer>) } Select for loading
  { }
  { (A"<name>") } Give name to set
  { }
  { "<ascii char>" <hex pair> ... } Load cell
  { <hex pair>; }

```

#### Character Cell Control Summary

```

R { (L) } Set selected for loading
  { }
  { (M(<keyletter>)) } Contents of macrograph
  { }
  { (M(=)) } Use of storage
  { }
  { "<free>,<total>" } Reply to use
  { }
  { (P) } Cursor position

```

#### Report Command Summary



APPENDIX E  
ANSI CODE EXTENSION TECHNIQUES

#### GENERAL

This section describes the ANSI code extension techniques as defined in ANSI standards X3.41-1974 and X3.64-1979 (ISO 2022 and 6429). (See the Accessories chapter for ANSI standards ordering information.) The description is based on the functions used in the VT100 and LA120 families of terminals. There are many special cases and details in the specifications that are not described here.

#### CLASSES OF CHARACTERS

The ANSI system is based on the use of classes of characters for specific purposes. The classes are determined by the characters' positions in the ASCII table (Figure E-1). This table and the ANSI system can work for either a 7-bit or an 8-bit character environment. Current terminals support only 7-bit characters.

#### CONTROL FUNCTIONS

All control characters and groups of characters (strings) that control the operation of the terminal and are not displayed on the screen are part of the system called control functions. Not all control functions perform an action in every device that understands ANSI, but each device can understand all control functions and discard any that do not apply to it. Therefore, each device is said to perform a subset of the ANSI functions.

#### COMPLIANCE WITH ANSI

Because different devices use different subsets, compliance with ANSI does not mean compatibility between devices. Compliance only means that a given action, if defined in the ANSI standard, is caused by the same control function in all devices. If an ANSI device does not perform an action that has a control function defined in the ANSI standard, it cannot use that control function for any other purpose.

For example, ESC c is Reset for devices meeting ANSI and having a remote reset function. Even if a device does not have this function, it still may not use ESC c for any other purpose. ESC 7 (Save Cursor Position), however, is a private sequence and may be used for other purposes by devices from other manufacturers. But within DEC, each private sequence is registered in an internal standard so that all DEC products use each sequence for only one purpose.

BITS				0 0		0 0		0 1		0 1		1 0		1 0		1 1		1 1		
BITS				0		1		2		3		4		5		6		7		
B7	B6	B5	ROW	COLUMN		COLUMN		COLUMN		COLUMN		COLUMN		COLUMN		COLUMN		COLUMN		
B4	B3	B2	B1	0		1		2		3		4		5		6		7		
0	0	0	0	0	NUL	0	DLE	20	SP	40	0	60	@	100	P	120	'	140	p	160
						0		16		32		48		64		80		96		112
						0		10		20		30		40		50		60		70
0	0	0	1	1	SOH	1	DC1 (XON)	21	!	41	1	61	A	101	Q	121	a	141	q	161
						1		17		33		49		65		81		97		113
						1		11		21		31		41		51		61		71
0	0	1	0	2	STX	2	DC2	22	"	42	2	62	B	102	R	122	b	142	r	162
						2		18		34		50		66		82		98		114
						2		12		22		32		42		52		62		72
0	0	1	1	3	ETX	3	DC3 (XOFF)	23	#	43	3	63	C	103	S	123	c	143	s	163
						3		19		35		51		67		83		99		115
						3		13		23		33		43		53		63		73
0	1	0	0	4	EOT	4	DC4	24	\$	44	4	64	D	104	T	124	d	144	t	164
						4		20		36		52		68		84		100		116
						4		14		24		34		44		54		64		74
0	1	0	1	5	ENQ	5	NAK	25	%	45	5	65	E	105	U	125	e	145	u	165
						5		21		37		53		69		85		101		117
						5		15		25		35		45		55		65		75
0	1	1	0	6	ACK	6	SYN	26	&	46	6	66	F	106	V	126	f	146	v	166
						6		22		38		54		70		86		102		118
						6		16		26		36		46		56		66		76
0	1	1	1	7	BEL	7	ETB	27	,	47	7	67	G	107	W	127	g	147	w	167
						7		23		39		55		71		87		103		119
						7		17		27		37		47		57		67		77
1	0	0	0	8	BS	8	CAN	30	(	50	8	70	H	110	X	130	h	150	x	170
						8		24		40		56		72		88		104		120
						8		18		28		38		48		58		68		78
1	0	0	1	9	HT	9	EM	31	)	51	9	71	I	111	Y	131	i	151	y	171
						9		25		41		57		73		89		105		121
						9		19		29		39		49		59		69		79
1	0	1	0	10	LF	10	SUB	32	*	52	:	72	J	112	Z	132	j	152	z	172
						10		26		42		58		74		90		106		122
						10		1A		2A		3A		4A		5A		6A		7A
1	0	1	1	11	VT	11	ESC	33	+	53	;	73	K	113	[	133	k	153	{	173
						11		27		43		59		75		91		107		123
						11		1B		2B		3B		4B		5B		6B		7B
1	1	0	0	12	FF	12	FS	34	,	54	<	74	L	114	\	134	l	154		174
						12		28		44		60		76		92		108		124
						12		1C		2C		3C		4C		5C		6C		7C
1	1	0	1	13	CR	13	GS	35	-	55	=	75	M	115	]	135	m	155	}	175
						13		29		45		61		77		93		109		125
						13		1D		2D		3D		4D		5D		6D		7D
1	1	1	0	14	SO	14	RS	36	.	56	>	76	N	116	^	136	n	156	~	176
						14		30		46		62		78		94		110		126
						14		1E		2E		3E		4E		5E		6E		7E
1	1	1	1	15	SI	15	US	37	/	57	?	77	O	117	_	137	o	157	DEL	177
						15		31		47		63		79		95		111		127
						15		1F		2F		3F		4F		5F		6F		7F

**KEY**

ASCII CHARACTER	ESC	33	OCTAL
		27	DECIMAL
		1B	HEX

MA-7246

Figure E-1 ASCII Table

## CONTROL CHARACTERS

A control character is a single character which, when received by the terminal, starts, modifies, or stops a control function. The value of a control character is in the octal range of 0 through 37 and 177.

Chapter 4 of this manual explains the control characters that are understood by the terminal. All other control character codes are ignored by the terminal.

This terminal can perform some actions that are usually caused by control character codes from the 8-bit ASCII environment, which this terminal does not understand. It does this by understanding certain combinations of 7-bit codes, which other sections of this appendix will explain.

## ESCAPE SEQUENCES

One control character causes the function of waiting for more characters that are not in the control character numerical range. This is the Escape or ESC character (033(8)). This character is defined by ANSI standard X3.4-1977 as "Introducer". If the terminal receives this character, it waits for more characters to follow within certain numerical ranges to form an Escape Sequence as defined in ANSI X3.41-1974 and ANSI X3.64-1979.

The format of an Escape Sequence is:

ESC	I...I	F
033	040-057	060-176
Escape	Intermediate	Final
Sequence	Characters	Character
Introducer	(Any number	(One code)
	of codes - 0 or more)	

If following characters are in the range 040 -- 057(8) (column 2), they are called "Intermediate Characters". The device accepts and stores them.

If a following character is in the range 060 -- 176(8) (columns 3 to 7), it is a "Final Character". The final character signals the end of an Escape Sequence which the device then analyzes. Final characters from column 3 are for private control functions for use in a specific device. Final characters from columns 4 -- 7 are for ANSI standardized control functions.

Some two character escape sequences perform the same actions as some 8-bit single character control functions. The VT100 family supports six of these. ESC [ is CSI (see next section); ESC D is IND, ESC E is NEL, and ESC M is RI (see Cursor Positioning); ESC N is SS2 and ESC O is SS3 (see Character Sets and Selection). The VT125 also supports ESC P which is DCS and ESC \ which is ST (see Communication and Graphic Protocol Controls.)

The intermediate and final characters are taken together to define the function of the sequence. Then the device performs the action

and accepts more data. If the action defined by the escape sequence does not apply to the device, the device ignores the complete sequence and accepts more data.

Escape sequence examples (all examples have added spaces between characters to make them easier to read):

- ESC H = Set Tab at active position
- ESC ( B = Designate G0 Character Set as ASCII
- ESC # 6 = Double Width Line. (VT100) (6 = DEC Private)
- ESC ( Ø = Designate G0 character set as DEC private  
Special Graphics character set (Ø = private)

Example Sequence: Designate G0 Character Set as ASCII Select Character Set (SCS) = ESC ( B

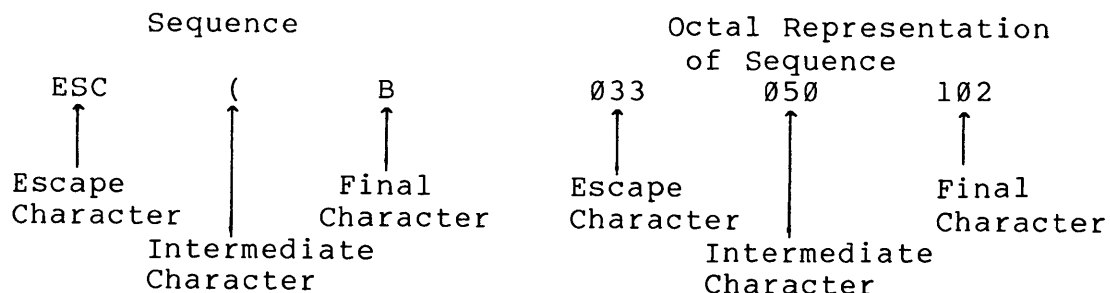

### CONTROL SEQUENCES

The string ESC [ is a two character escape sequence and represents the 8-bit control character CSI. This is "Control Sequence Introducer" and it precedes all control sequences in the same way that the ESC "Introducer" precedes all escape sequences. ESC [ allows the extended functions of the 8-bit control sequence environment to work in the 7-bit environment of current terminals. The control sequence is defined in ANSI X3.64-1979.

The format of a Control Sequence is:

CSI	P...P	I...I	F
Ø33 133	Ø6Ø-Ø77	Ø4Ø-Ø57	1ØØ-176
Control	Column 3	Column 2	Column 4-7
Sequence	Parameter	Intermediate	Final
Introducer	(Ø or more codes)	(Ø or more codes)	(One code)

A device parses this sequence without considering its meaning. That is, characters are stored in classes only according to their range of values. Then, the device interprets these characters by value according to their classes. The intermediate and final characters are taken together to define the function of the sequence. In the range of final characters, 1ØØ -- 157 (columns 4 -- 6) are reserved for standardization by ANSI, while 16Ø -- 176 (column 7) are reserved for private use.

## Parameters

The parameters modify the action or interpretation of the function. The parameters are from column 3 and may be any combination of the characters 0-9 (060-071) with each parameter separated from the others by ; (073). (The other characters in column 3 are : (072) which is reserved, and <=>? (074 -- 077) which are assigned for private use and mean that the following parameters have a private interpretation.) Any leading zero in a parameter is ignored; this also applies to the parameter value 0. Therefore a sequence with no parameter is the same as a sequence with a parameter of 0 and both are understood as having the default value for that parameter in the sequence.

A single parameter that modifies the action of a control function is called a numeric parameter and has the abbreviation "Pn". (Example: Cursor Up, ESC [ Pn A, where Pn is number of lines.) A parameter that defines the action of a control function by selecting from a list of possible actions is called a selective parameter and has the abbreviation "Ps". (Example: Set Mode, ESC [ Ps h, where Ps selects the mode to be set.) Control functions that have selective parameters can accept multiple parameters to allow several actions to be commanded with a single control function.

A sequence with multiple parameters has several "Ps" separated by ";" characters (Ps;Ps;Ps). This is called a parameter string. If the parameters apply to the screen image, their abbreviations indicate this: Pt;Pb for top and bottom, and Pl;Pc for line and column.

Character 077 (?) at the beginning of a parameter string means that the parameters are private parameters. That means the Control Sequence is standardized but the function that it controls is private. (Ex: Set and Reset Mode control functions.) Some control functions are defined to have a default value for a parameter. The default value is assumed when no parameter character is included in a sequence.

Examples with octal equivalents:

```
ESC [ 3 g = Clear all tabs
      033 133 063 147
```

```
ESC [ g = Clear tab at active position (default value = 0)
      033 133 147
```

```
ESC [ 16 ; 32 u = Set tabs at columns 16,32 (LA120)(u =
private)
      033 133 061 066 073 063 062 165
```

```
ESC [ ? 2 ; 3 h = Set modes 2 and 3 (? = private)
      033 133 077 062 073 063 150
```

```
ESC [ 20 h = Set Linefeed/New Line mode (parameter = 20)
      033 133 062 060 150
```

ESC [ 2 ; 1 y = Run Power-up selftest (VT100)(y = private)  
 033 133 062 073 061 171

NOTE: There are no examples of control sequences with intermediate characters because current terminals do not have any control functions in that format. However, new software written to understand the ANSI syntax should be able to parse sequences with intermediate characters. Future Digital terminal products may use intermediate characters.

Example Sequence: Control sequence to set modes for 132 column mode, smooth scrolling, and reverse screen. ESC[?3;4;5h

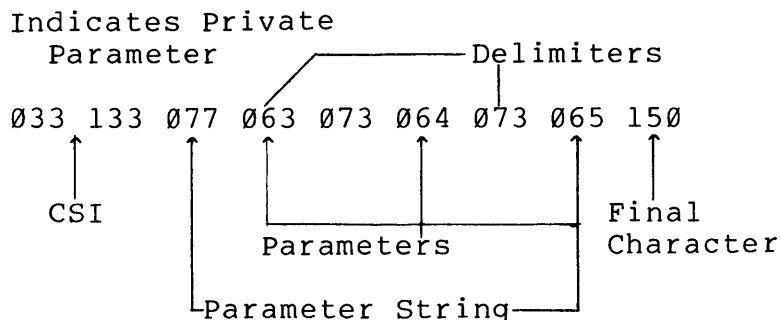
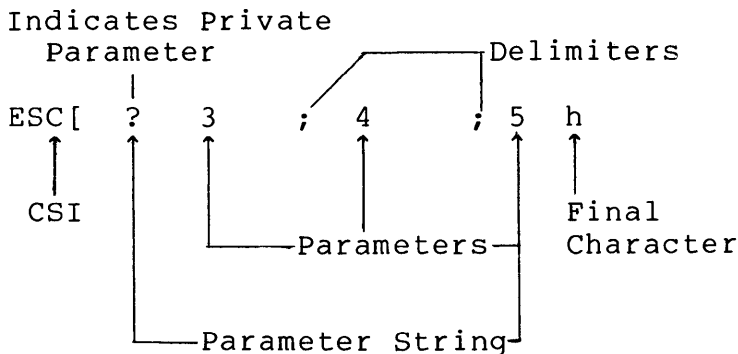

Alternate sequences that will do the same thing:

ESC[?3hESC[?4hESC[?5h (Parameters can be split into separate control sequences.)

ESC[?03;004;5h (Leading zeroes are ignored.)

#### ERROR RECOVERY

On the problem of incorrect control functions, the ANSI standards only say that error recovery techniques are not defined. These errors include out of range parameters, invalid control functions, and control characters embedded in control functions. The VT100 family recovers from errors with as much correct function as possible rather than discard any error. For example, if the VT100 receives a sequence asking it to move the cursor beyond the right margin, it moves the cursor to the right margin. In the LA120, a command to move beyond the right margin is ignored and the active position stays unchanged.

If a control character appears within a sequence, the VT100 performs the function of the control character (for example, a carriage return) as if it had been received before the beginning of the sequence. However, CAN and SUB appearing in a sequence stop the processing of the sequence at that point. The terminal returns to regular character processing and displays any characters remaining in the sequence.

A control function that is unrecognizable is ignored. Unsupported control functions (any apparently valid sequences that are not listed in this book) are generally ignored but may produce unpredictable responses.

NOTE: In the past, some programmers have used error condition actions in a given terminal to get the actions they wanted. This is not a safe practice in the ANSI environment because there is no guarantee that different ANSI-complying terminals will handle an error the same way. This would limit the transportability of code.

#### CHARACTER SETS AND SELECTION

G0, G1, C0, C1 Character Sets

The ANSI and ISO standards provide extensions to the range of graphic and control character sets in a terminal, in addition to the extension of control functions described in the preceding section.

A typical terminal transmits and receives the 7-bit ASCII character set. This character set has an eight column chart, and in it, columns 0 and 1 are control characters, while the rest of the set is graphics (except SP and DEL). SP (space) and DEL (delete) are always the same control characters with the same codes regardless of character set and so they are independent of character set selection.

The ANSI standards provide a system to allow the use of larger character sets in any terminal, without increasing the number of bits that the terminal must use to describe each unique character. Consider Figure E-2, the 8-bit ASCII chart.

The left side of the figure represents the familiar 7-bit ASCII character set. G0 and G1 are labels that are attached to character sets to indicate how the sets can be substituted for each other. The ANSI word for this is Designate. There are escape sequences that designate character sets as either G0 or G1. The control characters Shift Out (SO (016)) and Shift In (SI (017)), when included with 7-bit ASCII data, switch the display of a terminal from one character set to the other. The ANSI word for this is Invoke.

In the VT100, any character set whose display patterns are stored in the terminal can become either G0 or G1. SO always invokes the G1 set and SI invokes the G0 set. Sets can be invoked or designated at any time and in any order. Some character sets have been internationally registered, while others are private for use in a given terminal.

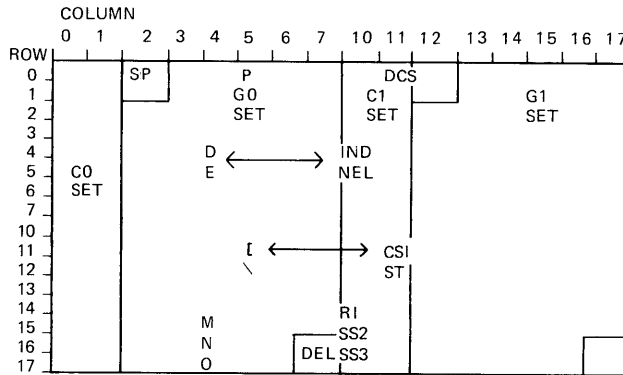

C0, C1 = CONTROL CHARACTER SETS  
 G0, G1 = GRAPHIC CHARACTER SETS  
 DCS, ST = VT125, VK100 ONLY

MA-6660

Figure E-2 8-Bit ASCII Chart

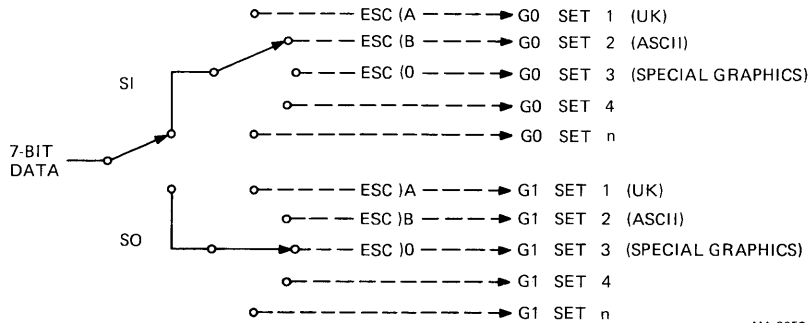

MA-6659

Figure E-3 Illustration of Shift-Out and Shift-In



In the VT100, the C0 control character set is normally available. There are escape sequences that cause the actions of single control functions of the C1 set on a one time basis. The ESC character followed by a final character from columns 4 or 5 causes the action of a control function that is also caused by a single 8-bit character in the C1 set. Figure E-2 shows how ESC [ causes the CSI function and ESC D causes the IND function from the C1 set. The other C1 characters that are supported in the VT100 family of terminals are also shown.

Figure E-3 shows a schematic representation of the Shift-Out and Shift-In concept. This figure shows how G0 and G1 character sets are designated by escape sequences and invoked by the SO and SI characters.



APPENDIX F  
CREATING COMPATIBLE ReGIS

This appendix lists the differences in implementation of ReGIS between the VT125 and the VK100 (GIGI). Use this information to create ReGIS images if you must use the same source on both terminals.

**1.0 COMPATIBLE REGIS SUMMARY**

Use ...	rather than ...
Four colors only; use S(M...) if not D, B, R, G.	More than four colors.
HLS or RGB in S(I...) and W(I...).	Numeric arguments to W(I...) and S(I).
S(I...,E).	S(E,I...).
W(V/R/E), W(N...).	W(F...), W(W...).
W(I,C).	W(C).
S(H[0,y1][767,y2]).	S(H[x1,y1][x2,y2]) or S(H[,y1][,y2]).
S[<0 to 767>,<0 to 511>].	S[ ] with negative or overrange numbers.
2000 or less characters of macrographs.	More than 2000 characters of macrographs.

**1.1 COMMAND DIFFERENCE SUMMARY**

**VT125**

- S(M...) selects color. S(I...) and W(I...) select one of the colors specified by S(M...), based on a closest-match algorithm.
- HLS color specifiers to S(M...), S(I...), and W(I...) specify one of 64 colors.

**VK100**

- S(I...) and W(I...) explicitly select colors.
- HLS specifiers select one of 8 colors.

## VT125

- S(In) and W(In) accept values of 0 to 3 for n.
- No S(W...).
- S(S...) controls screen scaling (zoom).
- S(H[x1,y1][x2,y2]) will hardcopy a specified rectangle from x1,y1 to x2,y2.
- S(H(P[x,y])) positions the hardcopy device at x,y before performing the hardcopy. Default value is [50,0].
- S(H...) performs scaling (zoom) on hardcopy if selected.
- No W(I) (no argument to I).
- W(F...) selects planes to be written.
- W(C) writing complements each plane individually, thus it may change the color.
- No W(A...).
- No locator mode; could be emulated in software.
- At least 5000 characters of macrograph storage.
- Concurrent text and graphics can be displayed by using "DCS 2 p" to enter graphics mode.

## VK100

- S(In) and W(In) accept values of 0 to 7 for n.
- S(W...) controls erase write operations.
- No S(S...).
- S(H...) only uses Y values of range.
- No S(H(P...)), defaults to [50,0].
- No scaling.
- W(I) allows writing of only the foreground/background plane, leaving the color unchanged.
- No W(F...).
- W(C) writing complements only the foreground/background plane, writing an explicit new color or leaving the color unchanged.
- W(An) selects "blink" attribute for writing.
- R(P(I...)) allows interactive positioning of a "locator" cursor. Also accessible by a keyboard command.
- At least 2000 characters of macrograph storage.
- SET-UP mode "GD" allows the last line of graphics commands to be displayed concurrently with graphics.

## VT125

- REGIS command parsing is not affected by "DCS p" and "ST". Using "DCS l p" will reset REGIS to top comand level.
- Graphics cursor cannot be disabled; it is present whenever the VT125 is processing REGIS graphics commands.
- Hardcopy output can be directed to the host port using the "Media Copy" control sequence.
- Hardcopy output is enclosed in a single "DCS q"/"ST" sequence, using the DECwriter control commands.
- Hardcopy image data sent to the VT125 will be displayed as if the VT125 was a hardcopy device.

## VK100

- "DCS p" resets REGIS to top command level.
- SET-UP mode "VC" selects whether the graphics cursor is displayed.
- Hardcopy output can be directed to the host port by swapping the cables.
- Hardcopy output is enclosed in "DCS q" on a line-by-line basis.
- Hardcopy data sent to the VK100 is ignored.



APPENDIX G  
THE HLS COLOR SYSTEM IN THE VT125

The display port for the external color monitor is driven by a six bit output map, providing 2 bits (4 levels) of intensity for each primary color: red, green, and blue. This section describes the general allocation of RGB specifiers based on HLS descriptors.

The HLS double cone model (Figure G-1) is divided into seven layers linearly spaced along the lightness axis. If lightness is not specified in a color descriptor, it defaults to 50%, the layer with the greatest variety of colors. The extreme layers, below 14% and above 86%, map to black and white respectively, regardless of H and S.

Each non-extreme lightness level is divided into one to three concentric rings based on the saturation parameter. If saturation is 0%, then the color specifier must map to one of four gray levels based on the lightness parameter. If saturation is not specified, it defaults to 100%.

Each non-gray lightness/saturation ring is divided into from three to twelve segments based on hue. Hue has no default. If not specified, then the lightness parameter again defines a gray level. By these defaults, the null specifier maps to the medium gray level in the VT125.

Percentage values for L and S of less than 0 or more than 100 map to 0% and 100% respectively. Hue is computed modulo 360.

The following table summarizes the color allocations derived from the above rules.

lightness	saturation	color range
0 to 14	any	black;
15 to 28	any >0	three primaries and simple secondaries;
29 to 42	1 to 49 50 to 100	three light primaries; nine shades, including middle lightness pure primaries;

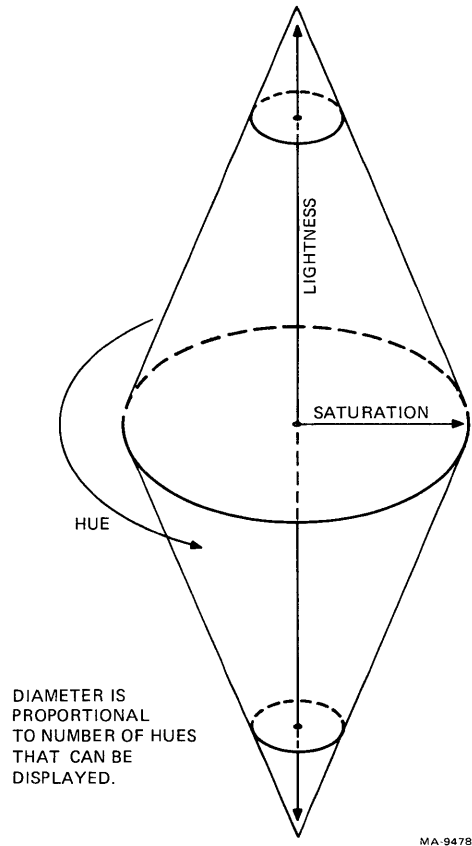

Figure G-1 HLS Double Cone Color Model



lightness	saturation	color range
43 to 57	1 to 33 34 to 66 67 to 100	three unsaturated secondaries; nine shades, including less saturated primaries; twelve shades, including the brightest pure primaries, almost brightest pure secondaries, and the six shades in between;
58 to 71	1 to 49 50 to 100	three unsaturated primaries; nine shades, including the brightest pure secondaries;
72 to 85	1 to 49 50 to 100	three very unsaturated primaries; three less than fully saturated secondaries;
86 to 100	any	white;

The primaries are red, green, and blue. The secondaries are yellow, cyan, and magenta.

When saturation is 0% or hue is unspecified, lightness values 0 to 24, 25 to 49, 50 to 74, and 75 to 100 map to black, dim gray, brighter gray, and white respectively.



APPENDIX H  
ReGIS COMMAND LISTINGS

This appendix lists the ReGIS commands used to create art for this book.

FIGURE 5-3

```
p[200,100](b)[+15,-15] t'[200,100]' p(e) v(b)[200,200](b)
p(b)[+10,-15] t'[200,200]' p(e)
v[300,400] p(b)[+5] t'[300,400]' p(e) v[400,300]
p(b)[+5,-5] t'[400,300]' p(e) v(e)c[+5]
v[100,50] p(b)[-85,-10] t'[100,50]' p(e) v(e)c[+10]
p[100,430]t(s1)"p[200,100] v(b)[200,200](b) v[300,400]
v[400,300] v(e)c[+5] v[100,50] v(e)c[+10]"
```

FIGURE 5-4

```
p[384,240] c[+100,+50] c[+3]
p(b)[310,193] t'CURRENT POSITION'
p[285,213] t'(START END POSITION)'
p(e,b)[-40,+5] t'[384,240]'
p(e,b)[+100,+50] c[+3] p[+10] t'[+100,+50]'
p[300,390] t"p[384,240] c[+100,+50]"
```

FIGURE 5-5

```
p[284,300](b) c[+3] c(c)[+100,-100]
p(e,b)[-90] t'[284,300]'
p(e,b)[-150,+20] t'CURRENT POSITION'
p(e,b)[-180,+40] t'(START END POSITION)'
p(e)[+100,-100] c[+3] p[-50,-25] t'[+100,-100]'
p[240,400]t"p[284,300] c(c)[+100,-100]"
```

FIGURE 5-6

```

; 'Set defaults for text, writing commands'
t(d0,s1) w(v,p1)
; 'Set current position, mark and label it, add text above and below it'
p[384,240] c[+3] p(b)[-40,-50] t'CURRENT' p(e,b)[-40,-30] t'POSITION'
p(e,b)[+5,-12] t'[384,240]'
p(e,b)[-50,+10] t'(START END' p(e,b)[-40,+30] t'POSITION)' p(e)
; 'Draw arc, mark and label endpoints'
; 'Endpoint positions determined by temporarily embedding'
; 'other commands including r(p)'
c(a140)[+100,-100] p[+100,-100] c[+3] p[+5,-5](b) t'[+100,-100]'
p(e)[,+20] t'([489,135])'
p[242,253] c[+3] p[-85,+5] t'[242,253]'
; 'Draw arc with pattern to show drawing direction,'
; 'Leave gap for text'
p[384,240] [+90,-90] w(p4) c(a70c)[384,240] w(p0) c(a20c)[384,240]
p(b) p[+5,-15] w(v) t'140 degrees' p(e)
w(p4) c(a50c)[384,240] p[384,240] p[+90,-90][+7,-2]
; 'Vs drawn at endpoints'
w(p1) t(d225,s0)'V' p[256,251][-5,-10] t(d0,s1)'V'
; 'Print basic command'
p[240,350] t'p[384,240] c(a140)[+100,-100]'

```

FIGURE 5-7

```

; 'Mark and label radius of arc, move to start of arc'
p[384,140] c[+3] p(b)[-40,-30] t(s1)'[-100,-100]' p(e)[+100,+100]
; 'Mark and label current position'
c[+3] p(b,b)[+5,-20] t'START POSITION'
p(e,b)[+5] t'(CURRENT POSITION)' p(e)
; 'Draw arc'
c(a-90c)[-100,-100]
; 'Mark and label end position'
c[+3] p(b)[-125,-20] t'END POSITION' p(e,b)[-125] t'(NEW CURRENT'
p(e)[-125,+20] t'POSITION)'
; 'Return to start and draw inner arc with gap for text'
p(e)[-10,-10](b)[-2,-7] t(d-45,s0)'V' w(p4)
p(e) c(a-28c)[384,140] w(e,p0) c(a-34c)[384,140]
w(v,p1) p(b)[+10,-20] t(d0,s1)'-90' p(e,b)[,-5] t'degrees' p(e)
w(p4) c(a-28c)[384,140] p[+5,-4] t(d-135,s0)'V'(d0,s1)
; 'Add command'
w(p1) p[300,350] t'c(a-90c)[-100,-100]'

```

FIGURE 5-8

```

p[100,200](b) c[+3] c(s)[] [370,50] [420,360] [120,390] [](e)
r(e)[-90,-10] t'[100,200]' p[-50,+20] t'START POSITION'
p[370,50] c[+3] p[+7,-20] t'[370,50]'
p[420,360] c[+3] p[+5,+5] t'[420,360]'
p[120,390](b) c[+3] p[-90,-10] t'[120,390]' p(e)[-50,-30]
t'END POSITION' p[100,430]
t'p[100,200] c(s)[] [370,50] [420,360] [120,390] [](e)'

```

FIGURE 5-9

```
p[230,240] c[+5] c(b)[320,160] c[480,120]
c[570,160] c [480,240] c[320,280] c(e) c[+10]
p[230,240] (b) [-90,-10] t'[230,240]'
p(e,b)[-90,+10] t'START'
p(e)[-90,+30] t'POSITION'
p[320,160] c[+3] p[-80,-20] t'[320,160]'
p[480,120] (b) c[+3] p[, -30] t'[480,120]'
p(e)[, -50] t'END POSITION'
p[570,160] c[+3] p[+5,-10] t'[570,160]'
p[480,240] c[+3] p[+5,+5] t'[480,240]'
p[320,280] c[+3] p[, +5] t'[320,280]'
p[220,350] t(s1)'p[230,240] c(b)[320,160] [480,120]
[570,160] [480,240] [320,280] (e)'
```

FIGURE 5-11

```
P[100,0] T[+36,+0] (S[32,60],M[4,6]) 'ABCD'
P[100,85] T[+32,+28] 'ABCD'
P[200,255] T[-32,+44] 'ABCD'
P[100,60] T(S1) "T[+36,+0] (S[32,60],M[4,6]) 'ABCD' "
P[100,235] T(S1) "T[+32,+28] 'ABCD' "
P[100,450] T(S1) "T[-32,+44] 'ABCD' "
```

FIGURE 5-13

```
P[100,0] T[+36,+0] (S[32,60],M[7,10]) 'ABCD'
P[100,120] T[+36,+0] (S[32,60],M[1,2]) 'ABCD'
P[100,240] T[+36,+0] (S[32,60],M[4,6]) 'ABCD'
P[100,70] T(S1) "T[+36,+0] (S[32,60],M[7,10]) 'ABCD' "
P[100,190] T(S1) "T[+36,+0] (S[32,60],M[1,2]) 'ABCD' "
P[100,310] T(S1) "T[+36,+0] (S[32,60],M[4,6]) 'ABCD' "
```

FIGURE 5-15

```
p[100,150] t(d45,s4) 'ABCD'
p[100,200] t(d0,s1) 'p[100,100] t(d45,s4) 'ABCD' '
p[100,370] t(d45,s4,d0) 'ABCD'
p[100,420] t(d0,s1) 'p[100,400] t(d45,s4,d0) 'ABCD' '
p[400,200] t(d-45,s4,d0) 'ABCD'
p[400,400] t(d0,s1) 'p[400,200] t(d-45,s4,d0) 'ABCD' '
```

FIGURE 5-16

```
p[20,100] t(s8,i0) 'H'
p[20,250] t(s1,i0) 'p[20,100] t(s8,i0) 'H' '
p[350,100] t(s8,i-45) 'H'
p[250,250] t(s1,i0) 'p[350,100] t(s8,i-45) 'H' '
p[500,100] t(s8,i22) 'H'
p[500,250] t(s1,i0) 'p[500,100] t(s8,i22) 'H' '
```

FIGURES 5-17 to 5-20

```

;"FRAME.PIC"
p[50,50] c(a-90)[0,50]
w(v)p[50,0]v[717] c(a-90c)[717,50]
v[,430] c(a-90c)[717,430]
p[720,479] v[50] p[50] c(a-90c)[50,429]
v[,50] p[717,50] w(e)v[] p[25,25]
w(v)v[742][,454][25][,25]

;"WRMODE.PIC"
;set up box drawing macrograph
@:av[+200][,+200][-200][,-200]@;
;'set up erase macrograph'
@:ep[717,50]v(w(e,s1[,430]))[50]p[200,100]@;
@e
t(i0,s3)w(v,s1[,200]"/")@a

p[200,100]
p[+50,+50]w(s1"\")@a
p[180,400]t(s2)'OVERLAY WRITING'
;'the next command waits 2 seconds, then prints display'
s(t120,h(p[100,300]),h)@e

t(i0,s3)w(r,s1[,200]"/")@a
p[200,100]
p[+50,+50]w(s1"\")@a
p[180,400]t(s2)'REPLACE WRITING'
s(t120,h(p[100,300]),h)@e

t(i0,s3)w(v,s1[,200])@a
p[200,100]
p[+50,+50]t(a0)w(c,s1"\")@a
p[160,400]t(s2)'COMPLEMENT WRITING'
s(t120,h(p[100,300]),h)@e

t(i0,s3)w(v,s1[,200]"/")@a
p[200,100]
p[+50,+50]w(e,s1"\")@aw(v)
p[200,400]t(s2)'ERASE WRITING'
s(t120,h(p[100,300]),h)(e)

```

FIGURE 5-25

```

p[0,200] t(s10)'12345678'
p[0,0] v[767][,479][0][,0]
p[100,100] v[484][,340][100][,100]
p[0,0](b)[+5,+5] t(s1)'[0,0]'
p(e) [+25,+25]
v[95,95] p[-7,+2] t(d45s0)'v'
p[100,100][+5,+5] t(d0s1)'S[100,100]'
p[767,479][-95,-25] t'[767,511]'

```

## ANSI GLOSSARY

Active position	The character position on the visual display that will display the next graphic character.
ANSI mode	A VT100 mode that recognizes and responds only to escape sequences whose syntax and semantics comply with ANSI specifications. The graphics processor always is in ANSI mode.
Character position	Part of the visual display that can display a graphic symbol.
Control	A control character, escape sequence, or control sequence that performs a control function.
Control character	A character that can initiate, modify, or stop a control function.
Control function	An action that affects the recording, processing, transmission, or interpretation of data.
Control sequence	A sequence of characters used to perform a control function that begins with the control sequence introducer (CSI) control and may contain a parameter string.
Control sequence introducer (CSI)	An escape sequence that provides supplementary controls and is itself a prefix affecting the interpretation of a limited number of contiguous characters.
Control string	A string of characters that performs a control function and is delimited by an opening and closing delimiter control.
Cursor	A blinking reverse-video or underline that represents the active position.
Cursor control	A function that moves the active position.
Default	A function-dependent value assumed when no value, or a value of 0, is specified.

Display	The active area of the screen inside the scrolling region, or the entire screen, depending on the origin mode.
Escape character (ESC)	A control character that provides supplementary characters (code extension) and is itself a prefix affecting the interpretation of a limited number of contiguous characters.
Escape sequence	A sequence of characters used to perform a control function the first character of which is the escape (ESC) control character.
Final character	A character whose bit combination terminates an escape or control sequence designated by F.
Graphic character	A character, other than a control character, that has a visual representation normally handwritten, printed, or displayed.
Graphic object	A geometric shape that can be described with a few characters of information.
HLS	Hue, Lightness, Saturation. A three parameter system for describing a color on a video monitor.
Home	The character position at the origin. [See origin mode (DECOM)].
Intermediate character	A character whose bit combination precedes a final character in an escape or control sequence.
Macrograph	In ReGIS, any series of sequential commands that are stored in the terminal's memory and performed (invoked) on request by two characters. Macrographs reduce communication line traffic between the terminal and the computer when the same commands are used again and again.
Numeric parameter	A string of bit combinations that represents a number, designated by Pn or Ps.
Parameter	(1) A string of one or more characters that represents a single value, (2) The value so represented.
Parameter string	A string of characters that represent one or more parameter values.
Pixel	The smallest unit of information on a graphics display.



Protocol                   The conventions or rules for the format and timing of messages sent and received. Devices must be using the same protocol to understand each other.

ReGIS                     Remote Graphics Instruction Set. A set of graphics object description commands.

Selective parameter      A string of bit combinations that selects a subfunction from a specified list of subfunctions, designated by Ps. In general, a control sequence with more than one selective parameter causes the same effect as several control sequences, each with one selective parameter. For example, CSI Psa; Psb; Psc F is identical to CSI Psa F CSI Psb F CSI Psc F.

VT52 mode                A VT100 mode which recognizes and responds only to escape sequences which DEC VT52 type terminals use. The graphics processor does not have VT52 mode.



## OTHER TERMINALS

### GENERAL

The terminal is a vital link between the user and the power of the computer. Often the right terminal, or the right enhancement to your terminal, can make your work easier, more efficient, or more cost effective. For that reason, DIGITAL offers a full range of video and printer terminals and options that can help you tackle any application.

### PRINTER TERMINALS

DIGITAL's printer terminals are noted for their strength and reliability, selectable baud rates, and multiple user-selectable features, that provide all the flexibility you need to efficiently configure your work stations.

#### DECwriter III

DIGITAL's LA120 DECwriter III is the performance terminal for high-speed communications. At 180 characters per second the DECwriter III boosts throughput by combining bidirectional smart printing and a 100-character buffer with fast horizontal and vertical skipping over white space. The LA120 also offers the convenience and flexibility of more than 45 key-board-selectable features. These features include variable font sizes, tabs, form lengths, and many other time saving features previously available only as options. Mnemonic commands, prompting LED display, a special decal, and a convenient pocket-sized operator card all make the LA120 easy to set up and use.

A selectable baud rate (up to 9600) along with automatic self-test diagnostics give you the performance and reliability characteristics you look for in a high-speed communications terminal.

#### DECwriter IV

DIGITAL continues to develop new technology and better terminals with functional specifications our customers demand. The new DECwriter IV is the latest in small convenient printers. It comes in two models, both light and compact enough to be easily transported to the most convenient work station for maximum efficiency. The LA34 is the desk-top model with designer appearance and typewriter-like keyboard. It is smaller, lighter, and quieter than many typewriters. The easy-to-change ribbon

cartridge, roll-free paper, and convenient keyboard-selectable features -- like four character-width adjustments -- make this terminal simple enough for anyone to use.

The LA38 comes with tractor feed for multipart forms and includes roll feed for standard paper. A numeric keypad is standard for fast input of accounting data.

The DECwriter IV terminals include standard features such as microprocessor control, true 30 characters per second throughput, up to 9600 baud rate, and DECwriter reliability. These features give you all the performance you need in a convenient size package.

#### DECwriter IV Graphic Printer

DECwriter IV Graphic Printers are receive-only (RO) microprocessor-controller, low-cost, desk-top printers. They use an impact dot matrix printing technique for character representation. DECwriter IV Graphic Printers operate in one of two printing modes, text or graphic. In text mode, characters are printed as they are received. In graphic mode, received characters define columns of printed dots.

The printer can be used as an output device for a computer or word processor so that characters received from the computer are printed. The graphic printer can also be used as the output device for a graphic terminal such as the VT125 or the VK100.

#### VIDEO TERMINALS

DIGITAL's video display terminals offer unmatched convenience and capabilities with features designed to give you performance you would expect from much more expensive and complex equipment.

#### VIDEO TERMINAL

For the ultimate in video terminals, look to DIGITAL's VT100. It combines exceptional versatility with simplicity of operation. And it's designed to allow a wide range of fast and easy field upgrades to meet your changing needs. There is a detached typewriter-style keyboard with a flexible, 3-wire coiled cord. An 18 key numeric/function keypad on the keyboard permits single keystroke control of application-specific functions. The VT100 fits easily on a standard typewriter table. There is an advanced video option that provides 132-column lines of the screen for easy viewing of wide-line printer reports. Double height/double width characters are selectable line by line for easier reading and text formatting. Smooth scrolling a scan at a time lets your operators read new lines at a reasonable speed. Divided-screen displays; blinking, underlining, double intensity and normal or reverse video character attributes; keyboard and/or computer-settable tab stops; built-in, self-test diagnostics; pictorial capability; and many, many more.

**digital**

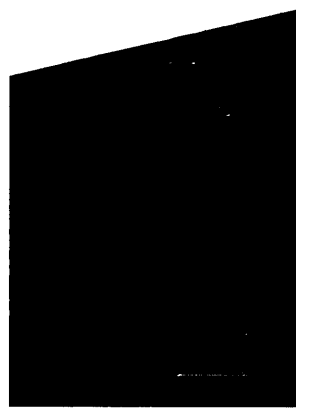

## TECHNICAL DOCUMENTATION CHANGE NOTICE

### VT125 User Guide Additions and Corrections (EK-VT125-UG-001)

Change step 9, Page 8-5, to read:

9. Connect the communication cable to the appropriate connector at the back of the terminal. If using the EIA interface, install the EIA line filter connector with a 5 mm (3/16 in) screwdriver (Figure 8-3). Then fasten the cable connector to the terminal tightening the captive screws with a 3 mm (1/8 in) blade screwdriver. Be sure to attach the cable ground wire to one of the captive screws. (Refer to Chapter 5 for information about connector use and signal/pin definitions.)

Replace the existing Figure 8-3 with this new one:

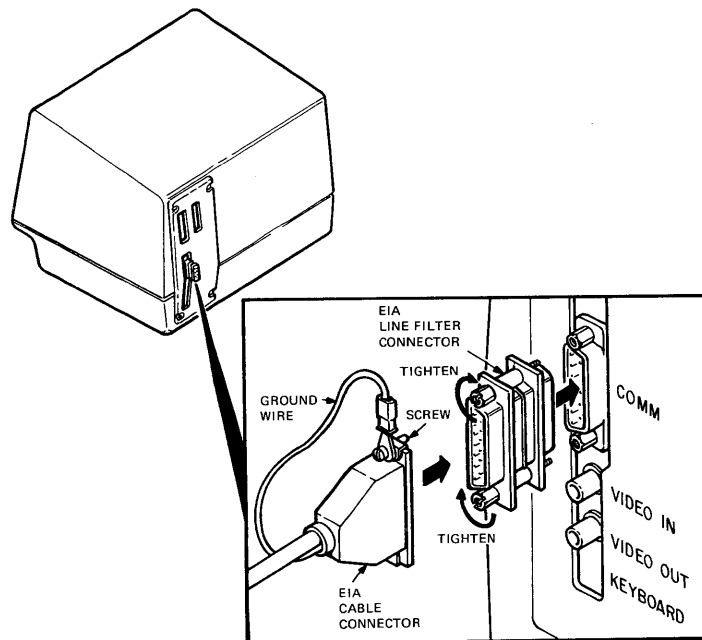

Change the VT125 Upgrade Installation Procedure in Chapter 10:

- Add one to the figure numbers from 10-11 to 10-16, making them 10-12 to 10-17.
- Change the old Figure 10-17 to Figure 10-11.
- Change step 17 on Page 10-16 to read:
  17. Install the VT100 end of the 16-pin flat cable connector to the lower 16 pins of the terminal controller board's graphic connector (marked J2 on the terminal controller board), with the cable entering from the right (Figure 10-12).

Change step 21 on page 10-21 to read:

21. Arrange the 16-pin graphic connector with the cable entering from above and install it into the connector at the top edge of the VT125 board (Figure 10-15).

Change step 29 on Page 10-21 to read:

29. Perform the installation, power-up, and checkout procedure that is described in Chapter 8. If using the EIA interface, be sure to install the EIA line filter connector as shown in Figure 8-3.