

MICRO-USB-PORT

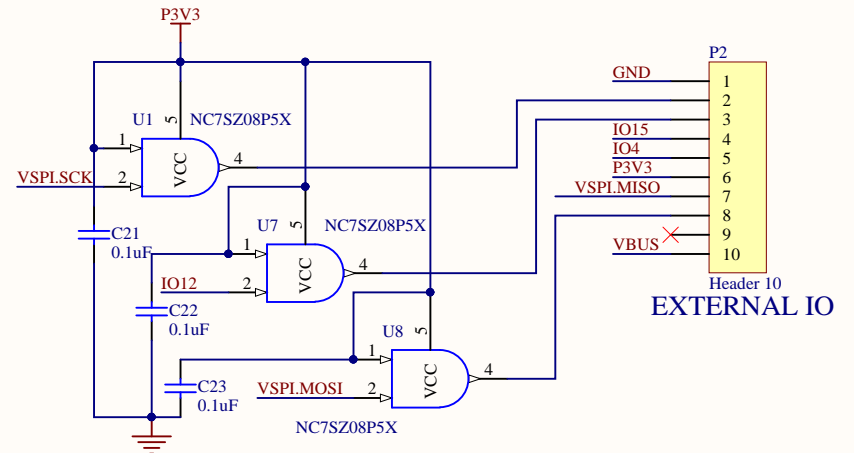

EXTERNAL IO

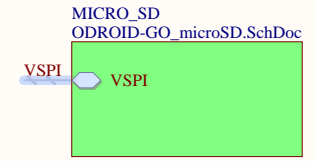
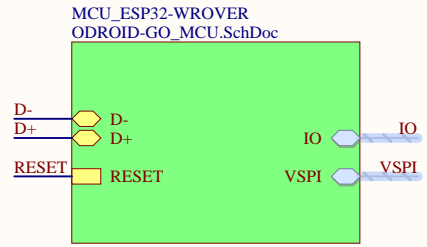
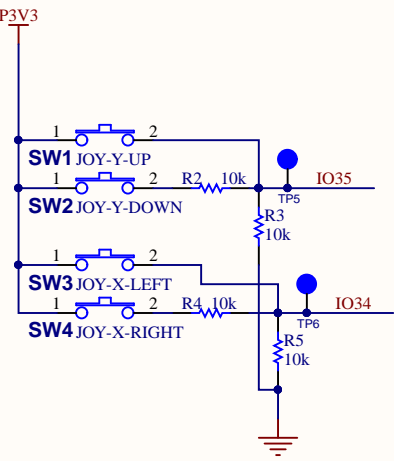
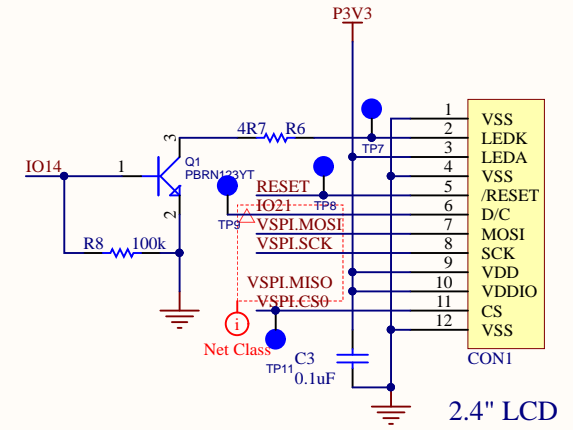
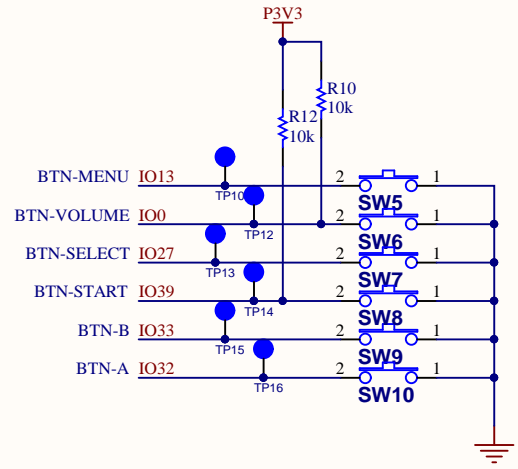
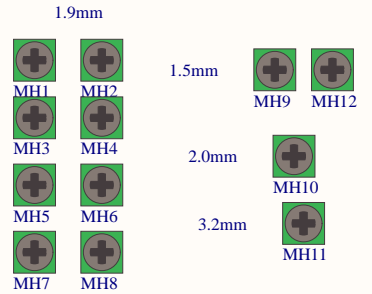
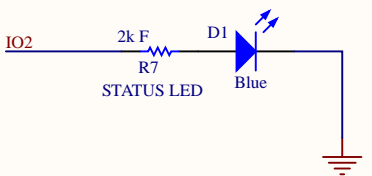
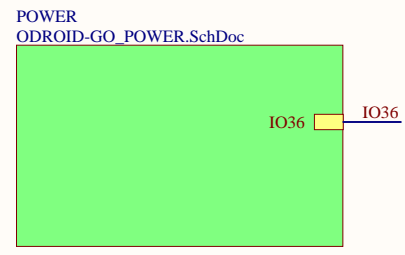

2.4" LCD

Title ODROID-GO		Hardkernel Co.,LTD. 475-1 Mananro Manangu, Anyang City Gyeonggido South Korea		
Size: A4	Number: 1	Revision: 0.1	Designed by: john.lee@hardkernel.com	
Date: 2018-06-18	Time: 오후 6:30:49	Sheet 1 of 4		
File: ODROID-GO.SchDoc				

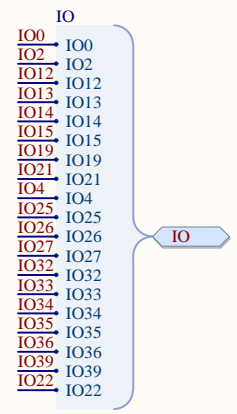
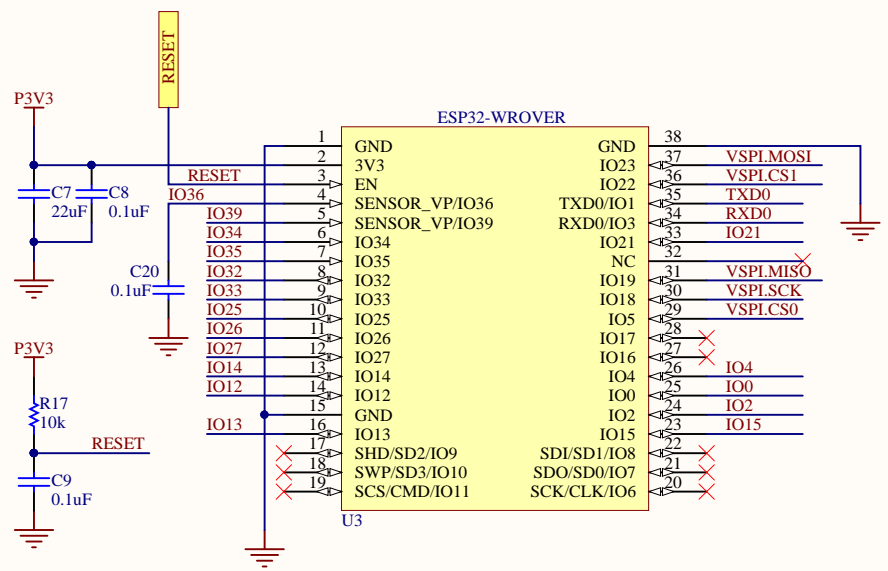
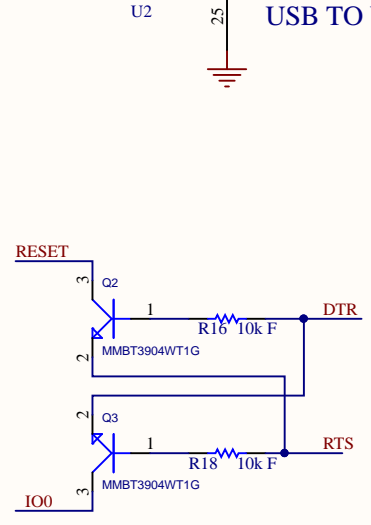
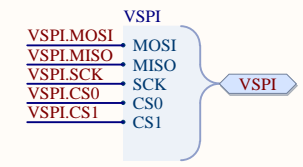
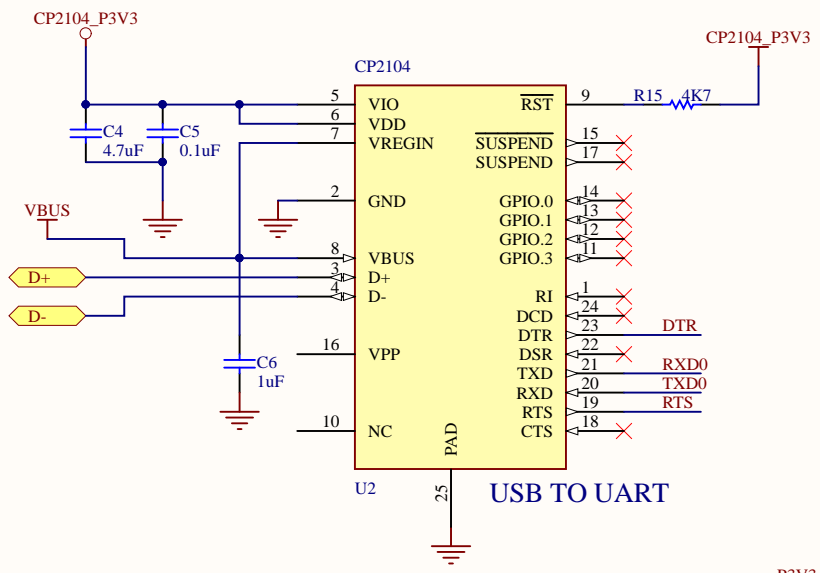

Title MCU			Hardkernel Co.,LTD. 475-1 Mananro Manangu, Anyang City Gyeonggido South Korea	
Size: A4	Number: 1	Revision: 0.1	Designed by: john.lee@hardkernel.com	
Date: 2018-06-18	Time: 오후 6:30:49	Sheet 2 of 4		
File: ODROID-GO_MCU.SchDoc				



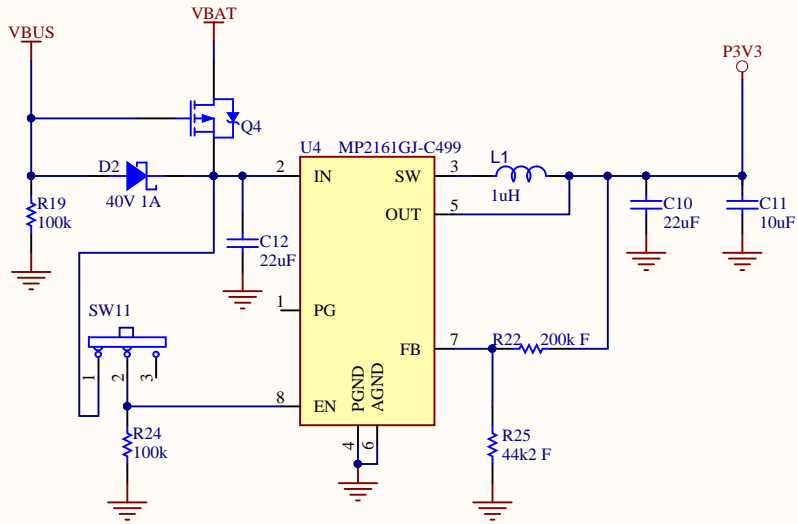

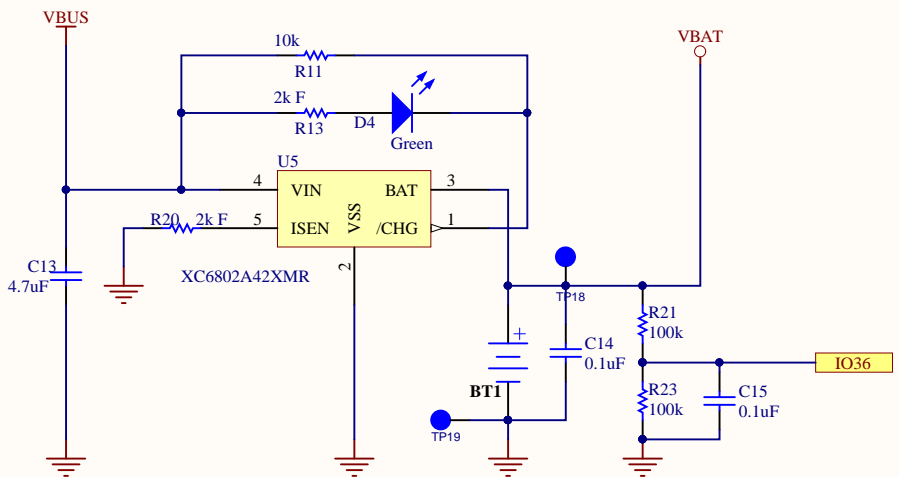

DC-DC CONVERTOR

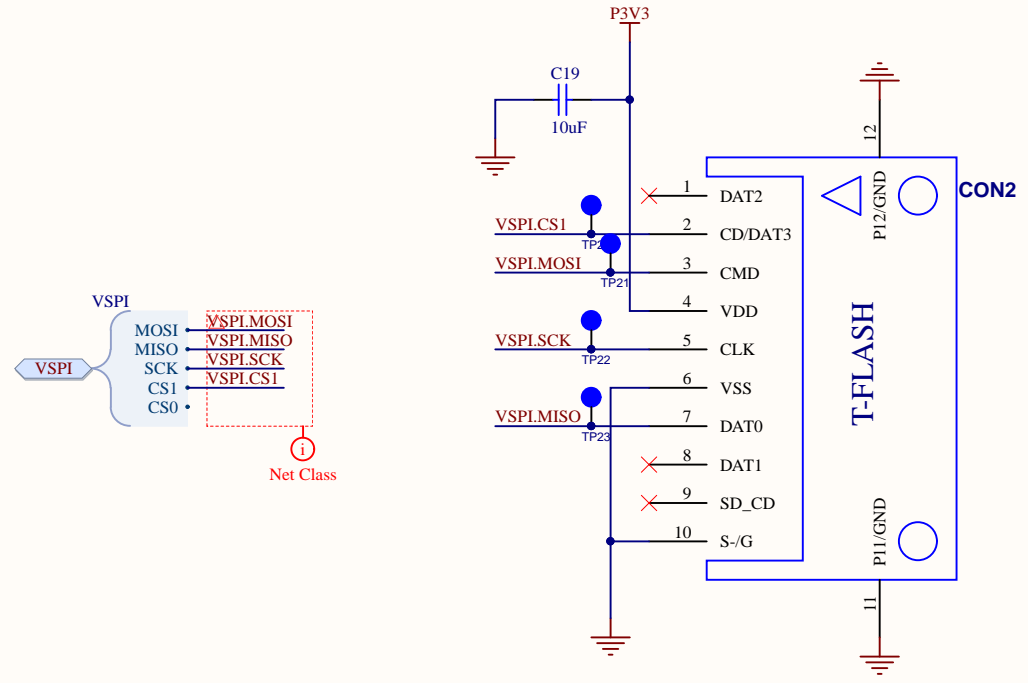

BATTERY CHARGER

Title Power			Hardkernel Co.,LTD. 475-1 Mananro Manangu, Anyang City Gyeonggido South Korea		
Size: A4	Number: 1	Revision: 0.1	Designed by: john.lee@hardkernel.com		
Date: 2018-06-18		Time: 오후 6:30:49	Sheet 3 of 4		
File: ODROID-GO_POWER.SchDoc					



Title Micro SD			Hardkernel Co.,LTD. 475-1 Mananro Manangu, Anyang City Gyeonggido South Korea	
Size: A4	Number: 1	Revision: 0.1		
Date: 2018-06-18	Time: 오후 6:30:49	Sheet 4 of 4		
File: ODROID-GO_microSD.SchDoc				