

2

1

B

B

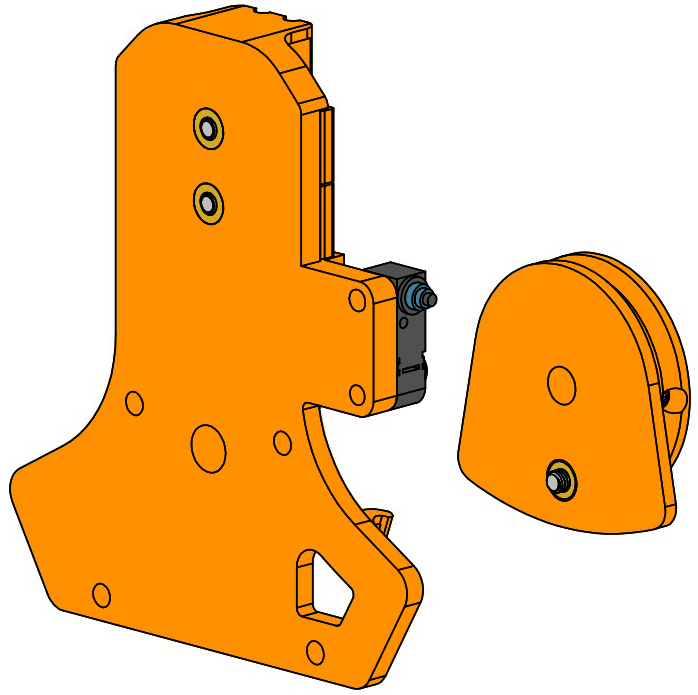
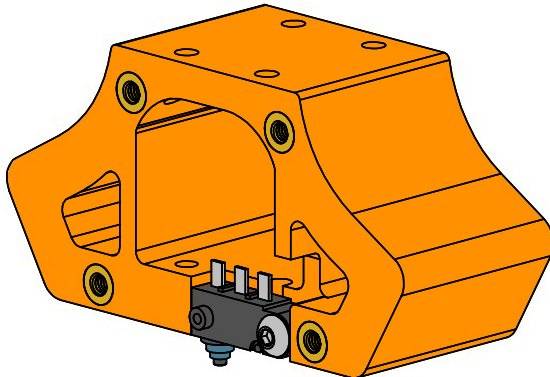
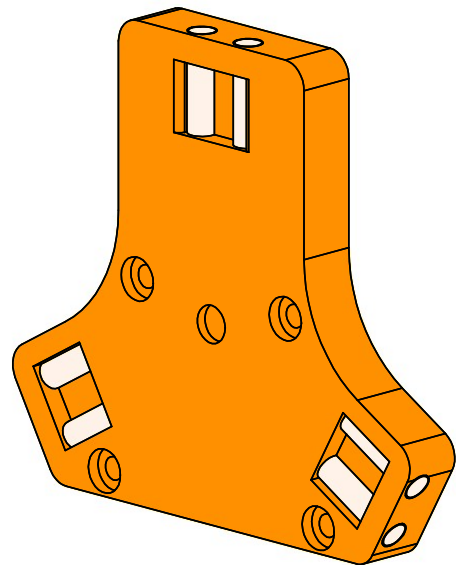

A

A

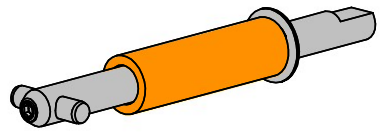

2

1

Toolchanger Carriage Assembly		
	Created by: Joshua Vasquez	last edited: 9/29/2020
	SCALE: 1:1	SHEET 1 OF 7

2

1

B

B

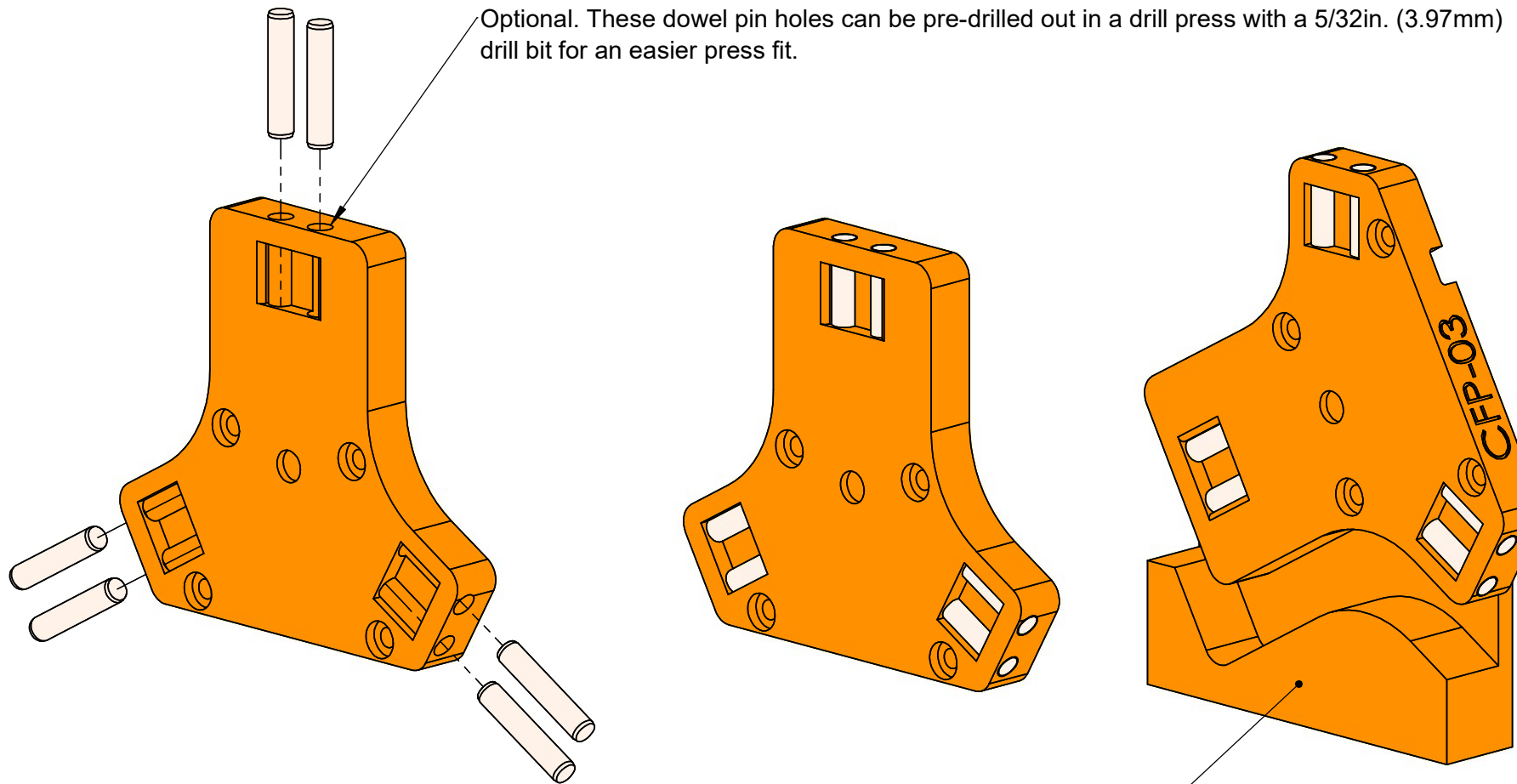

Press-fit each dowel pin into each socket until it is flush with the surface.

Use the pin insertion fixture to hold the Carriage Front Plate at the right angle for pin insertion.

A

A

ITEM NO.	DESCRIPTION	QTY.
1	Carriage Front Plate	1
2	M4 Dowel Pin, 20mm long	6
3	Pin Insertion Fixture	1

Coupling Plate Assembly



Created by:
Joshua Vasquez

last edited:
9/29/2020

SCALE: 1:1

SHEET 2 OF 7

2

1

2

1

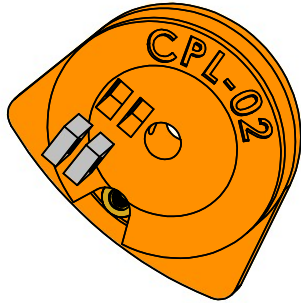

Step 1: Press-fit the square nut such that it is flush with the top face.

Note that the outer square nut will have a slightly looser fit.

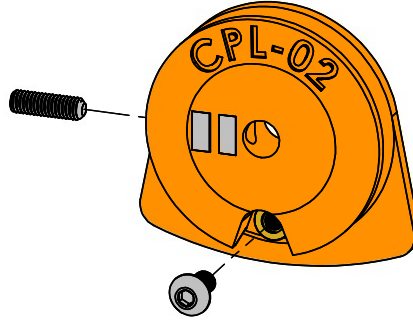

Step 2: Loosely install both screw components such that they engage the threads. The set screw should not peek out into the center hole. The buttonhead screw will be tightened later.

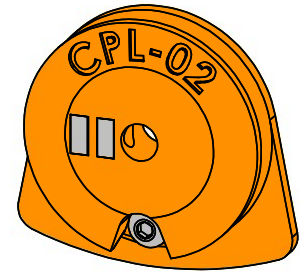

B

B

A

A

ITEM NO.	DESCRIPTION	QTY.
1	Tool Lock Pulley with Insert	1
2	M3 Square Nut	2
3	M3 Buttonhead Screw, 6mm long	1
5	M3 Set Screw, 10mm long	1

Pulley Assembly



Created by:
Joshua Vasquez

last edited:
9/29/2020

SCALE: 1:1

SHEET 3 OF 7

2

1

2

1

B

B

Center the dowel pin before tightening the set screw.

Install E-clip onto the shaft groove.

Slide shim onto the back of the E-Clip.

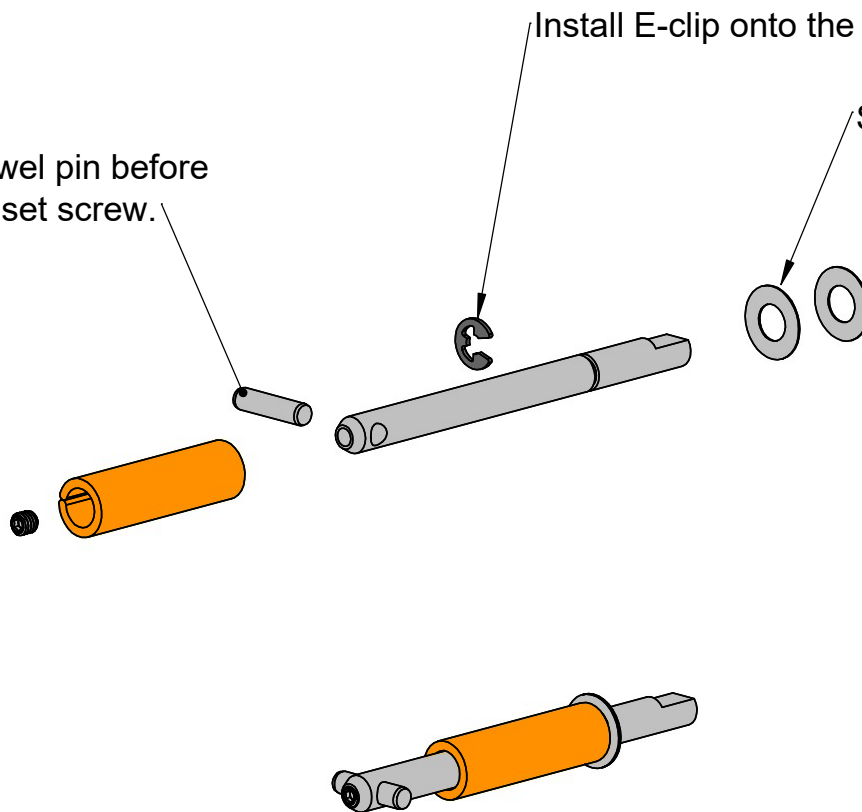

A

A

ITEM NO.	DESCRIPTION	QTY.
1	Twist Lock Shaft	1
2	M3 Dowel Pin, 12mm long	1
3	M3 Set Screw, 3mm long	1
4	E-Clip	1
5	M5 Shim, 0.2mm thick, 10mm OD	2
6	Twist Lock Spacer	1

Twist Lock Assembly



Created by:
Joshua Vasquez

last edited:
9/29/2020

SCALE: 1:1

SHEET 4 OF 7

2

1

2

1

B

B

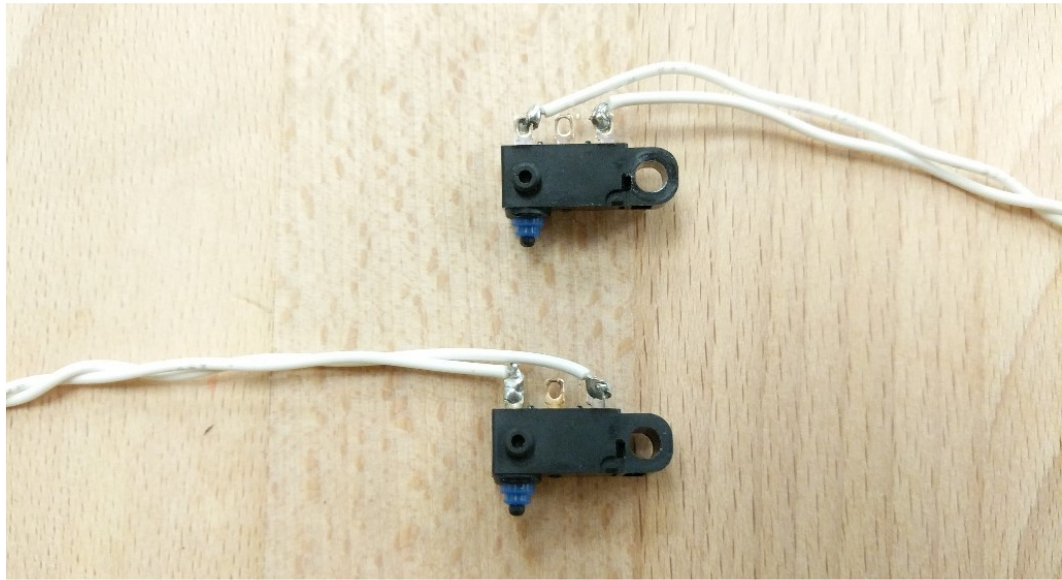

(Optional: twist the wires into two pairs for easier cable management.)

Solder two wires to the outer ends of each limit switch with the wires bent in the directions shown above. Note that the direction is different for each limit switch!

A

A

ITEM NO.	DESCRIPTION	QTY
1	900mm of 26AWG stranded white wire	4
2	Dust Proof Limit Switch	2

Wiring Installation		
	Created by: Joshua Vasquez	last edited: 9/29/2020
	SCALE: 1:1	SHEET 5 OF 7

2

1

2

1

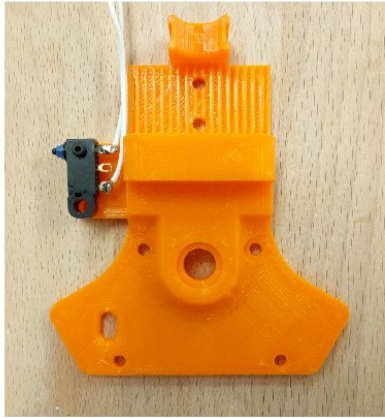

Select the limit switch with wires bent towards the button.

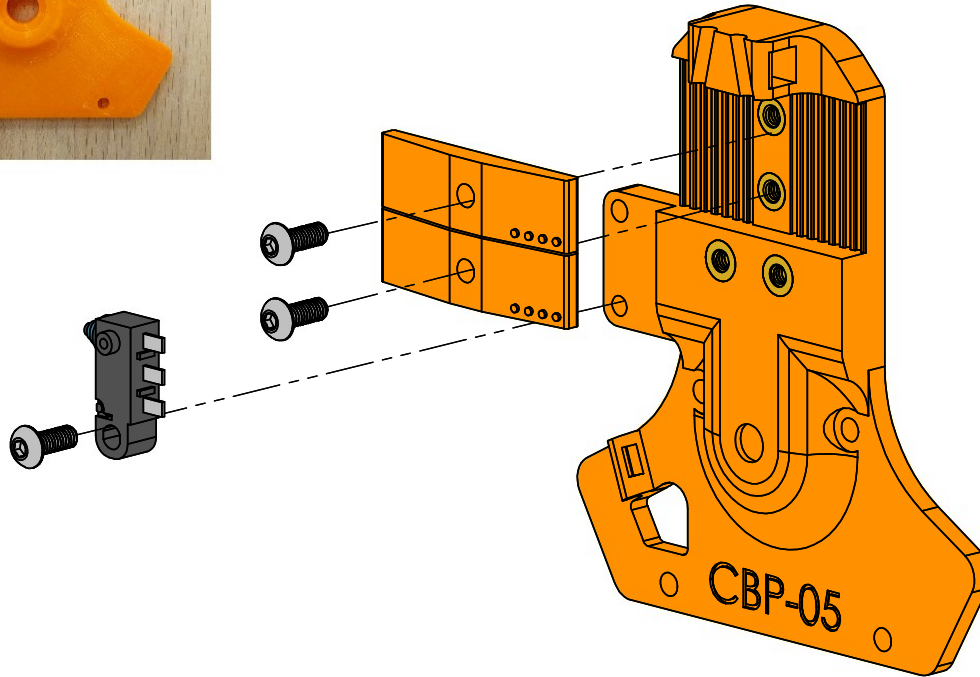

Exploded View

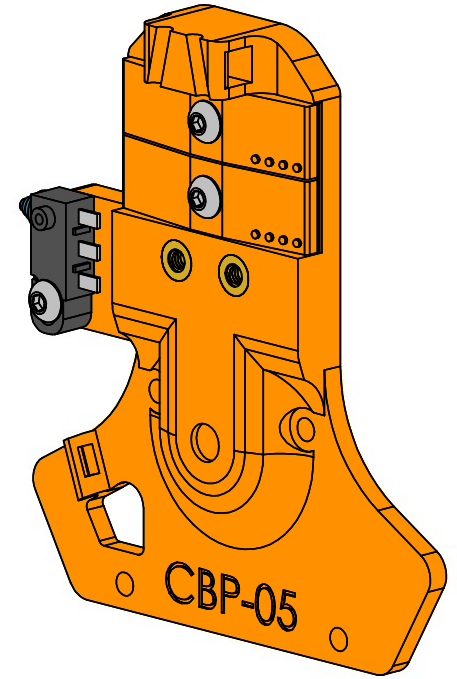

Assembled View

ITEM NO.	DESCRIPTION	QTY.
1	Dust-Proof Limit Switch	1
2	M3 Buttonhead Screw, 8mm long	3
3	Belt Clasp	2
4	Carriage Back Plate with Inserts	1

Carriage Back Plate Assembly



Created by:
Joshua Vasquez

last edited:
9/29/2020

SCALE: 1:1

SHEET 6 OF 7

2

1

B

B

A

A

B

B

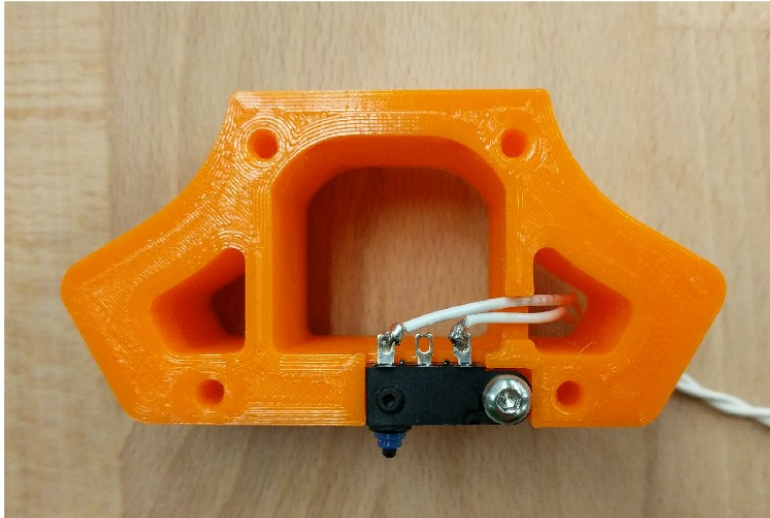

Select the limit switch with wires bent away from the button. Route the wires as shown above.

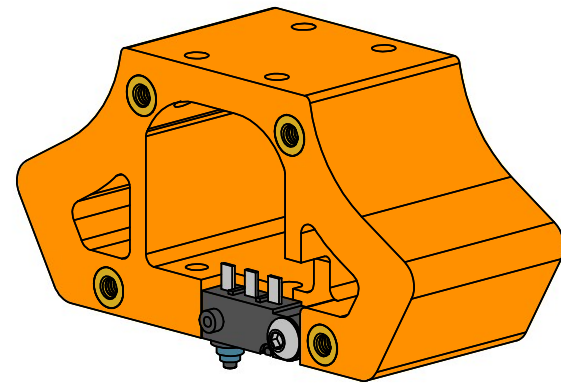

Set all completed subassemblies aside for installation on the CoreXY frame at a later step.

A

A

ITEM NO.	DESCRIPTION	QTY.
1	Dust-Proof Limit Switch with wires installed	1
2	M3 Buttonhead Screw, 8mm long	1
3	Carriage Center Plate	1

Carriage Center Assembly		
	Created by:	last edited:
	Joshua Vasquez	9/29/2020
	SCALE: 1:1	SHEET 7 OF 7