

USB-C connector and PD-sink controller

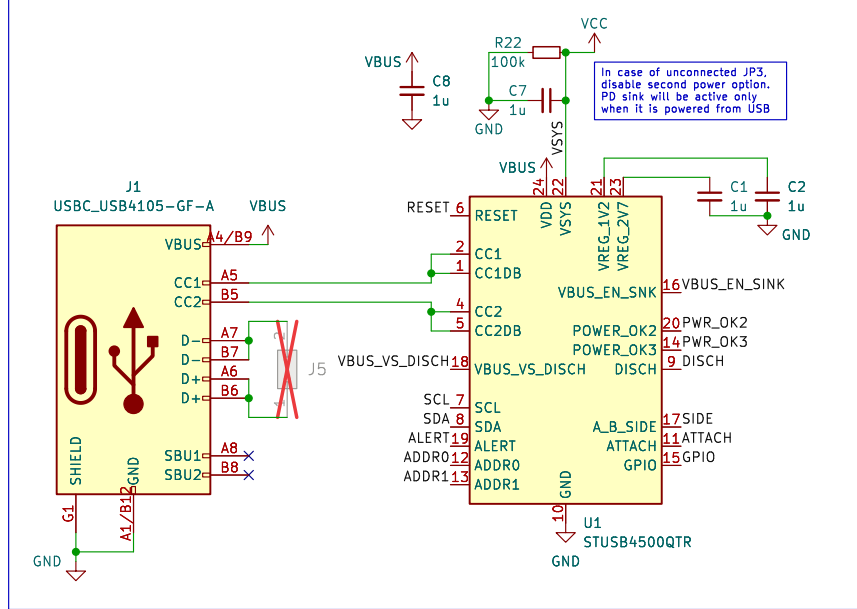

Output disconnector

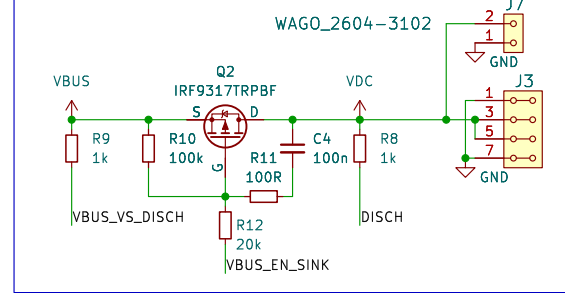

I2C connector and pull-ups

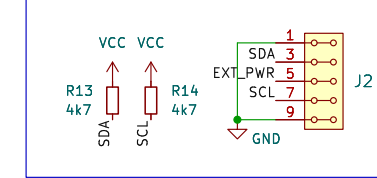

Power selector

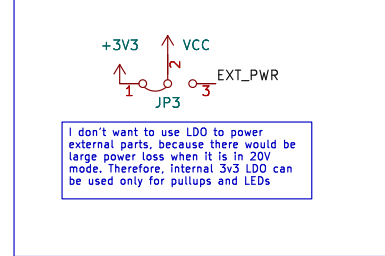

Connectors

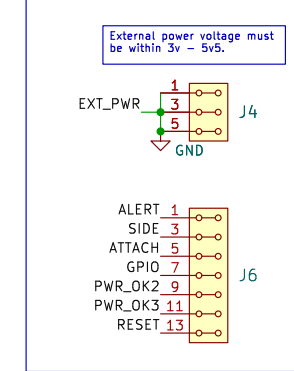

Addr selector

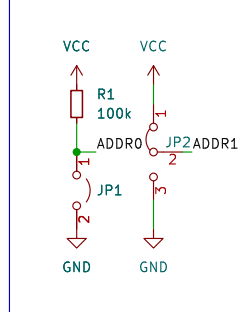

Signal pull-ups

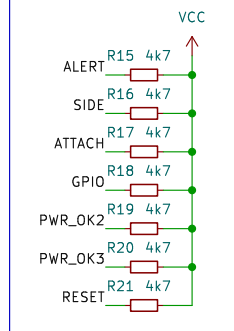

LED indicators

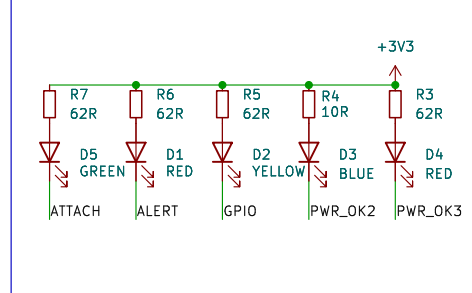

Mounting holes

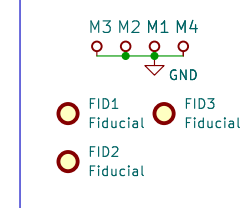

LDO for internal purposes

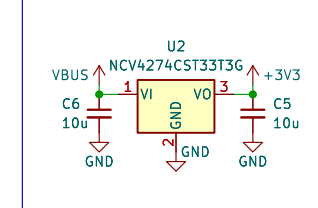

Title: USBPDSINK01A

USB-C PD sink controller

Author: roman-dvorak <romandvorak@mlab.cz>

Size: A4

Page: 1/1

Date:

