

ECE 350
Real-time
Operating
Systems



Lecture 8: Caching

Prof. Seyed Majid Zahedi

<https://ece.uwaterloo.ca/~smzahedi>

Outline

- Principle of locality
 - Temporal locality: Locality in time
 - Spatial locality: Locality in space
- Cache organizations
 - Direct-mapped, set-associative, fully-associative
- Major categories of cache misses
 - Compulsory, conflict, capacity, coherence
- Translation lookaside buffer (TLB): caching applied to address translation
 - Cache relatively small number of PTEs
 - On TLB miss, page table is traversed

Caching Concept

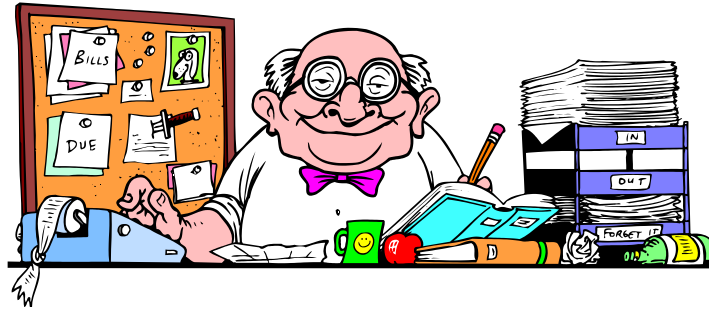

- **Cache** is repository for copies that can be accessed more quickly
 - Make frequent case fast and infrequent case less dominant
- Caching underlies many techniques used today to make computers fast
 - We can cache memory locations, address translations, pages, file blocks, file names, network routes, etc...
- Only good if
 - Frequent case is frequent enough and
 - Infrequent case is not too expensive

Why Bother with Caching?

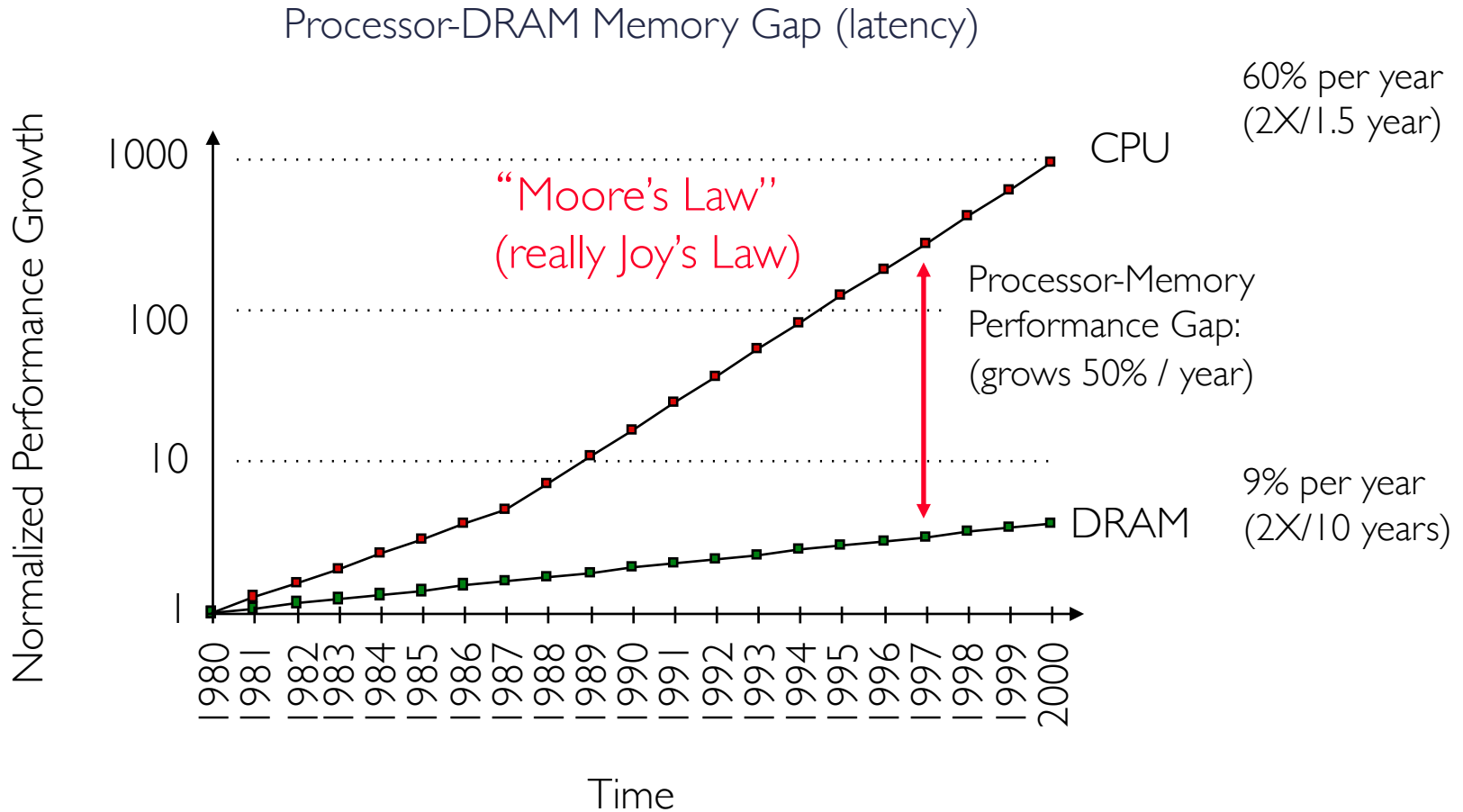

Why Does Caching Help?



- Temporal locality (locality in time):
 - Cache recently accessed data items
- Spatial locality (locality in space):
 - Cache contiguous blocks

Some Terminology

- **Block**: group of spatially contiguous and aligned bytes (words)
 - Typical sizes are 32B, 64B, 128B
- **Hit**: access cache and find what we want
 - **Hit time**: time to hit (or discover miss)
- **Miss**: access cache and fail to find what we want
 - **Miss time**: time to satisfy miss
 - Misses are expensive (take a long time) \Rightarrow try to avoid them
 - But, if they happen, amortize their costs \Rightarrow bring in more than just specific word you want \Rightarrow bring in whole block (multiple words)

Some Terminology (cont.)

- **Hit rate** = num of hits / (num of hits + num of misses)
 - Miss rate = $1 - \text{hit rate}$
 - High hit rate means high probability of finding what we want
- **Average access time** = hit rate \times hit time + miss rate \times (hit time + miss time)
= hit time + miss rate \times miss time
- Problem: hard to get low hit time and miss rate in one memory structure
 - Large memory structures have low miss rate but high hit time
 - Small memory structures have low hit time but high miss rate
- Solution: use hierarchy of memory structures

Memory Hierarchy of Modern Computer Systems

- Goal: bring average memory access time close to L1's

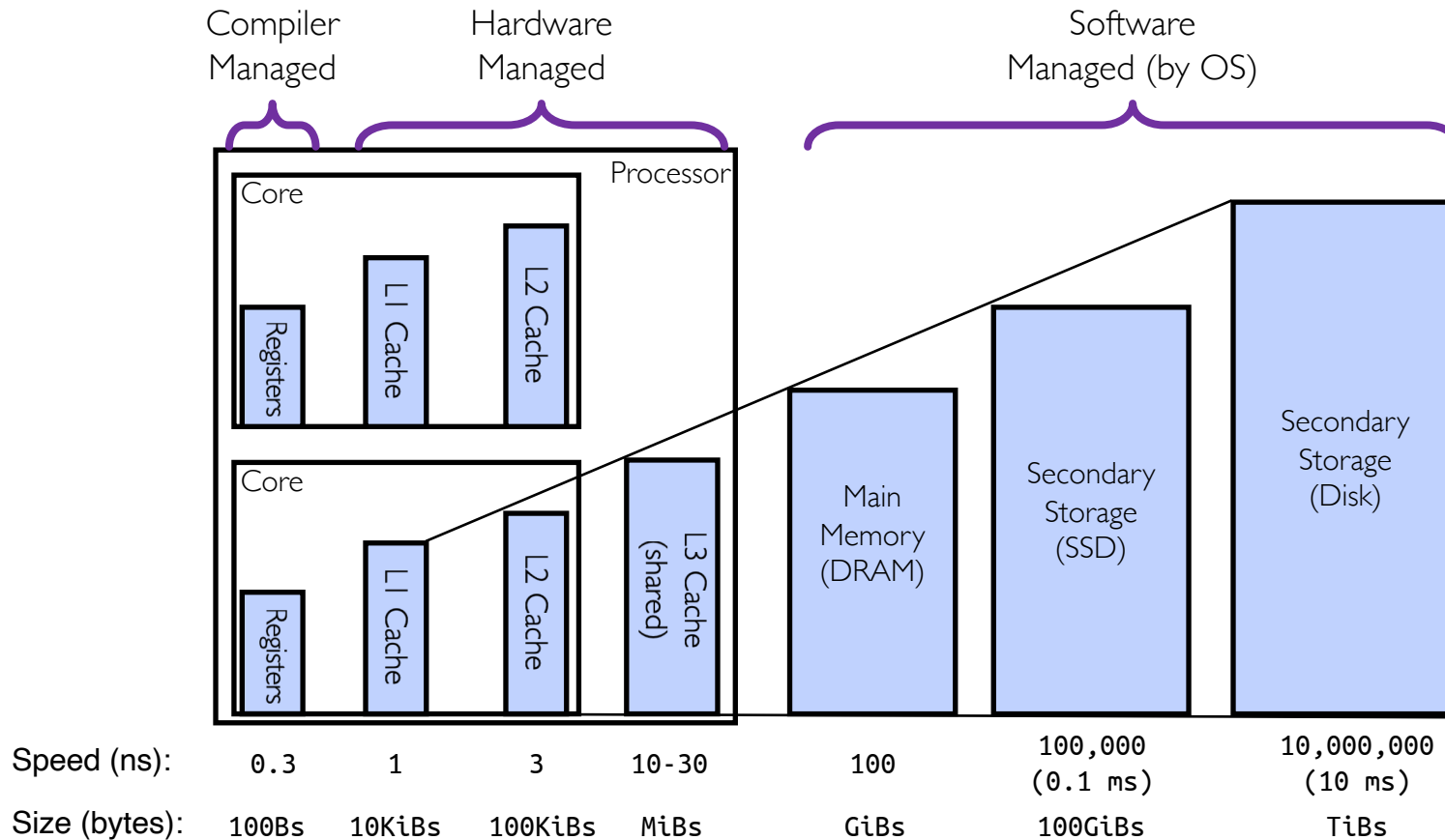

Abstract Hierarchy Performance

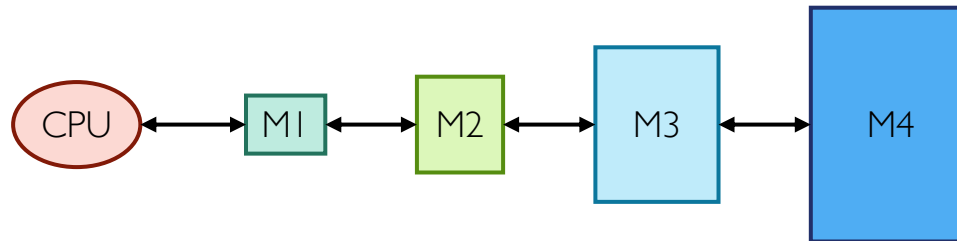

Miss time at level X = Average access time at level $X + 1$

Avg. memory access time = Avg-time_{M_1}

$$= \text{Hit-time}_{M_1} + (\text{Miss-ratio}_{M_1} \times \text{Miss-time}_{M_1})$$

$$= \text{Hit-time}_{M_1} + (\text{Miss-ratio}_{M_1} \times \text{Avg-time}_{M_2})$$

$$= \text{Hit-time}_{M_1} + (\text{Miss-ratio}_{M_1} \times (\text{Hit-time}_{M_2} + (\text{Miss-ratio}_{M_2} \times \text{Miss-time}_{M_2})))$$

$$= \text{Hit-time}_{M_1} + (\text{Miss-ratio}_{M_1} \times (\text{Hit-time}_{M_2} + (\text{Miss-ratio}_{M_2} \times \text{Avg-time}_{M_3})))$$

$$= \dots$$

Caching Questions

- 8-byte cache, 32-byte memory, 1 block = 1 byte
- Assume CPU accesses 01100

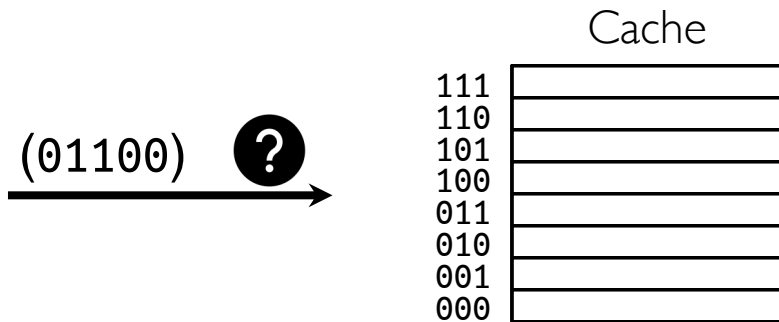

- How do you know whether byte @ 01100 is cached?

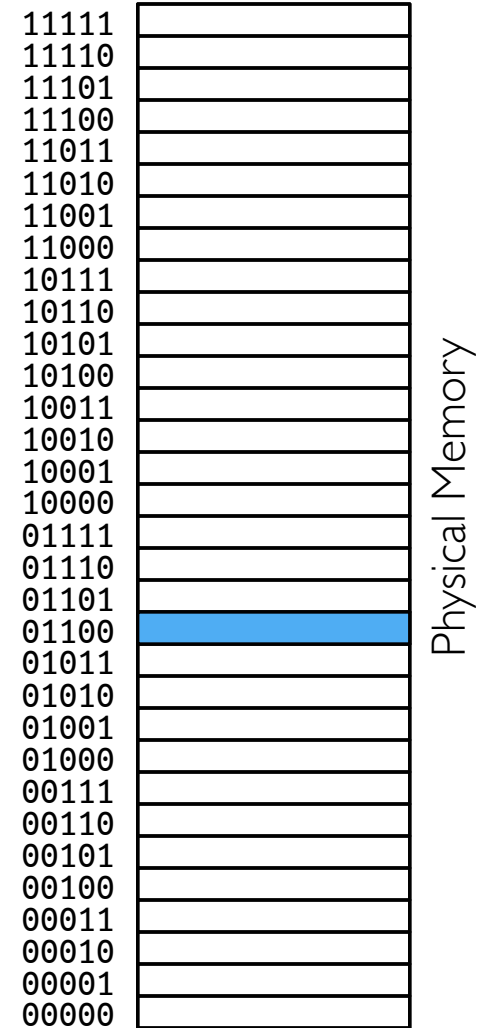

Caching Questions (cont.)

- 8-byte cache, 32-byte memory, 1 block = 1 byte
- Assume CPU accesses **01100**

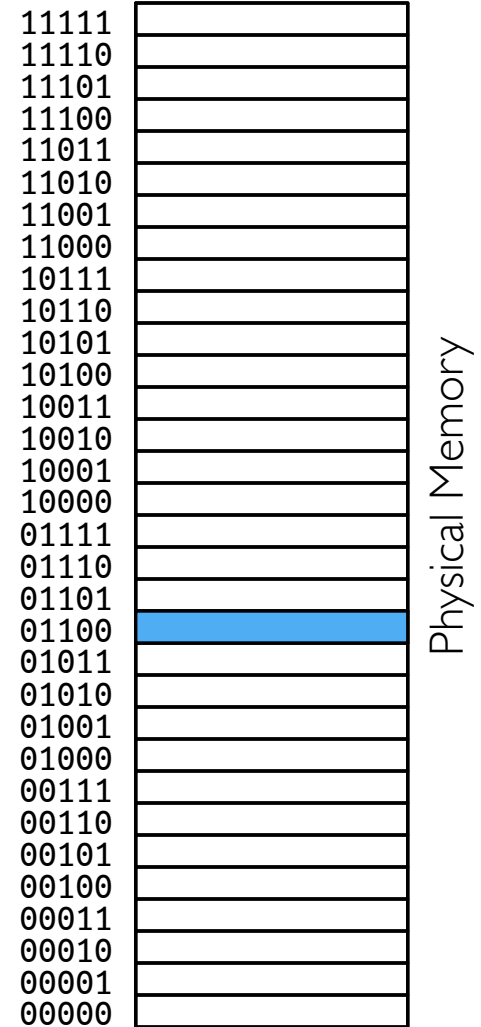
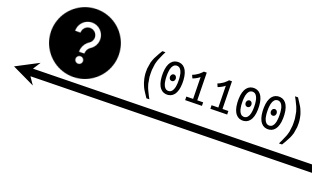
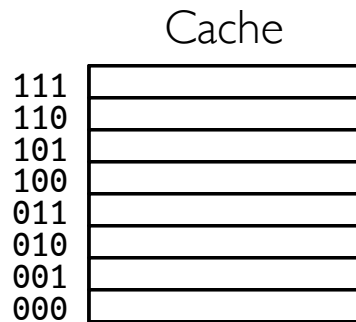

- How do you know whether byte @ **01100** is cached?
- If not, at which location in cache should it be placed?

Caching Questions (cont.)

- 8-byte cache, 32-byte memory, 1 block = 1 byte
- Assume CPU accesses **01100**

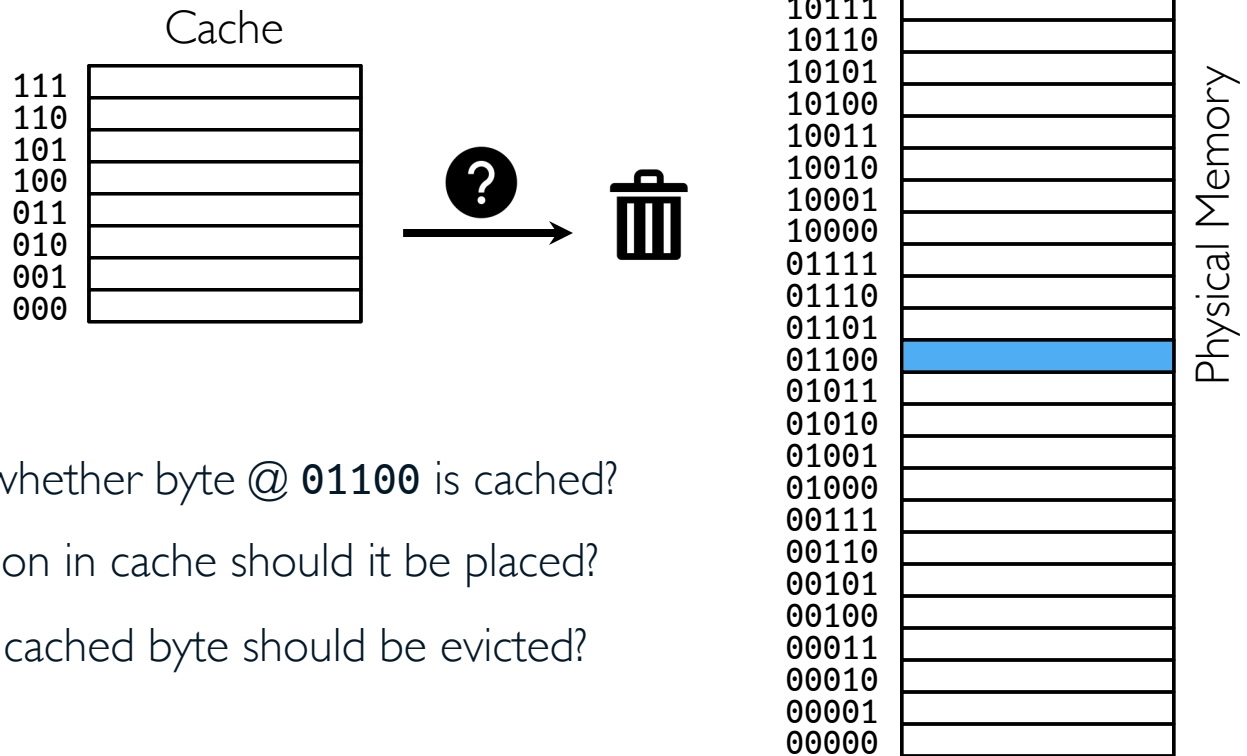

- How do you know whether byte @ **01100** is cached?
- If not, at which location in cache should it be placed?
- If cache is full, which cached byte should be evicted?

Where to Put Blocks in Cache?

- Divide cache into disjoint **sets** of blocks
 - There is 1-to-1 mapping from block address to set
- **M-way set-associative cache**: each set holds M number of blocks
 - E.g., 4 blocks per set \Rightarrow 4-way set-associative cache
- **Fully-associative cache**: whole cache has just one set
 - + Most flexible
 - - Longest access latency
- **Direct-mapped cache**: each set has one block (= 1-way set-associative)
 - + Shortest access latency
 - - Least flexible

Example: Direct-mapped Cache

- Each byte (block) in physical memory is cached to single cache location
 - Least significant bits of address (last 3 bits) index cache
 - (00**100**), (0**1100**), (1**0100**), (1**1100**) cached to 100

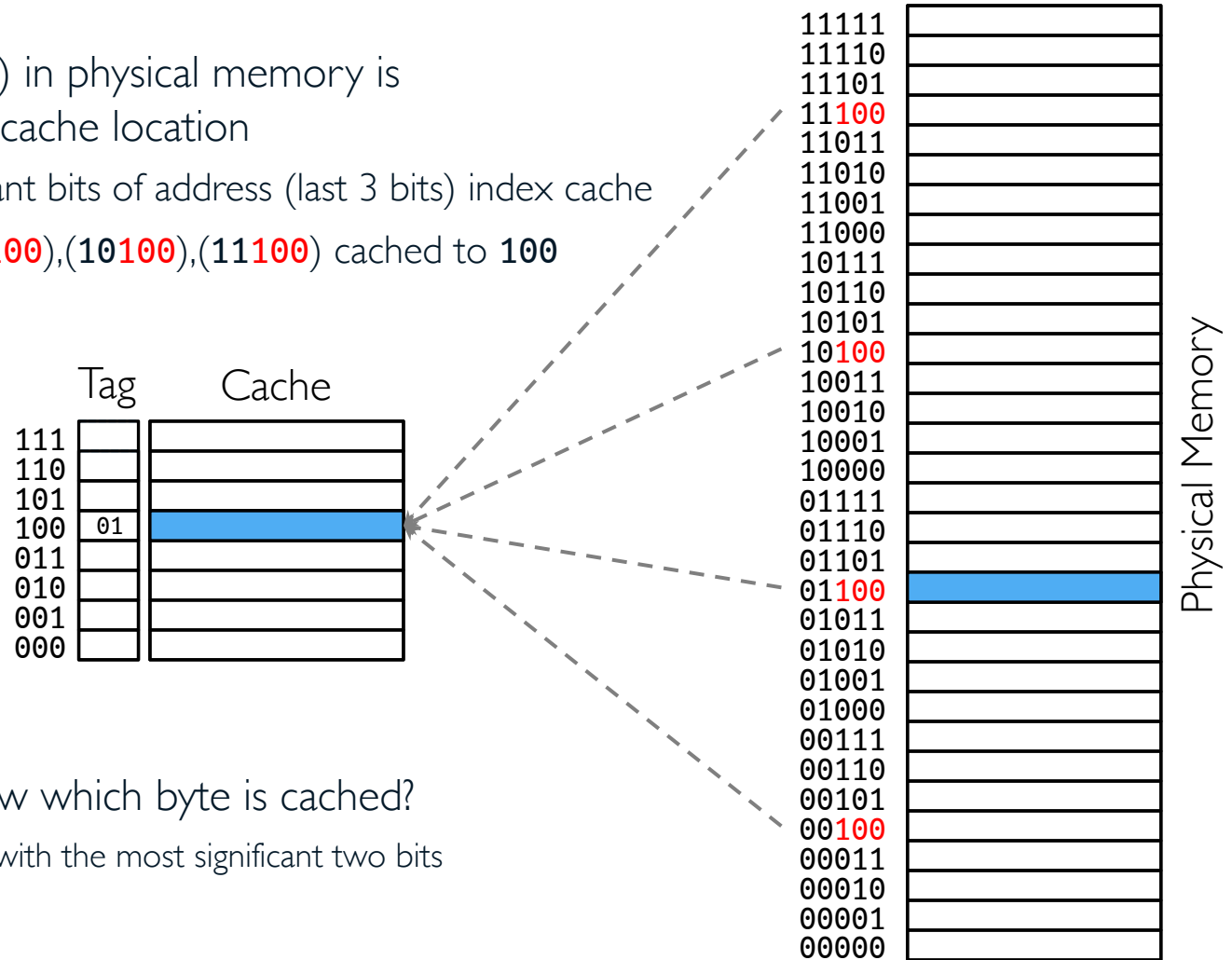

- How do we know which byte is cached?
 - Tag each byte with the most significant two bits

Example: Fully-associative Cache

- Each byte (block) can be stored at any location in cache
- How do you know which byte is cached?
 - Tag entire address of cached byte

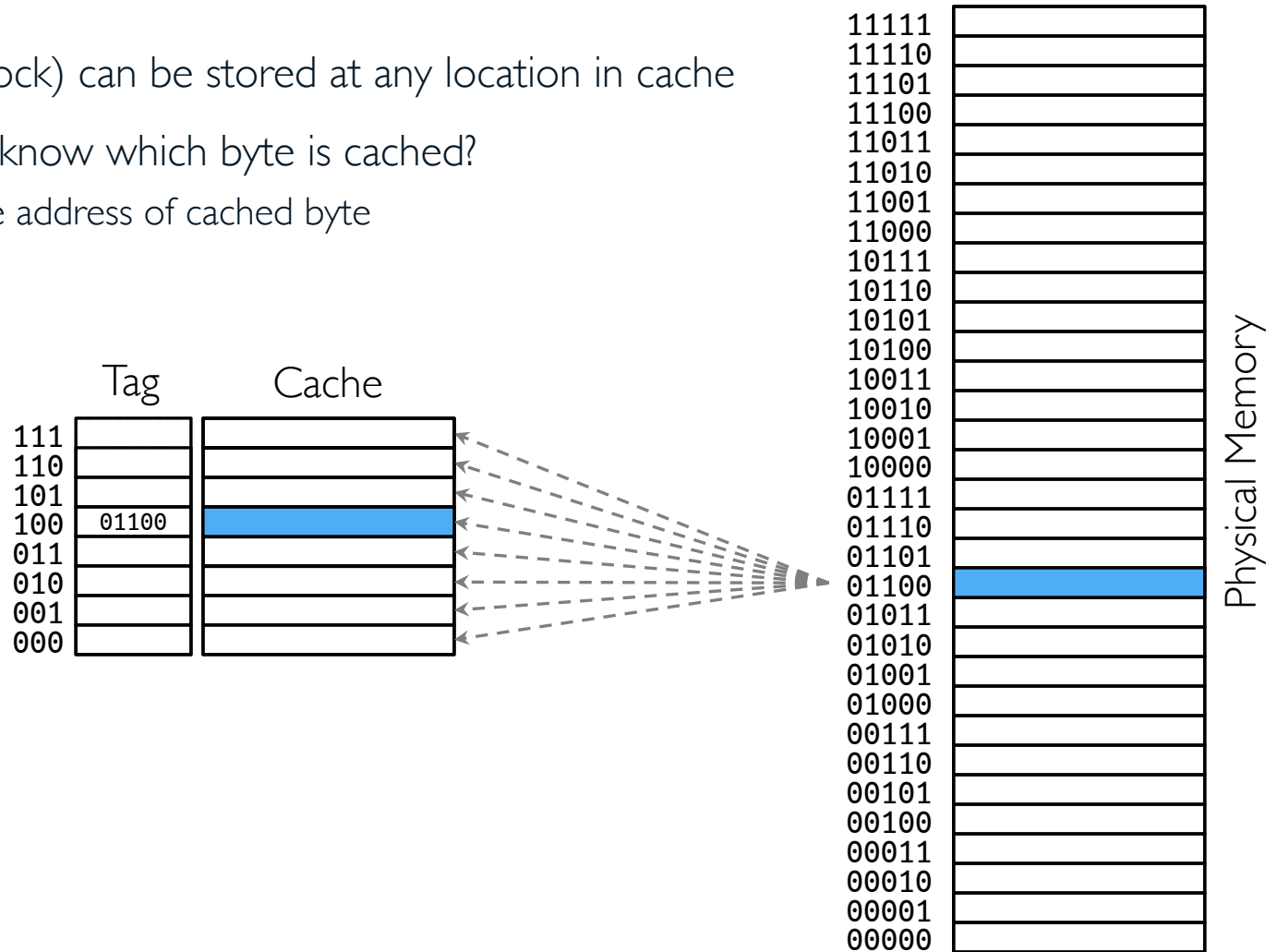

Where to Put Blocks in Cache? (cont.)

- Example: where is block 12 placed in 8-block cache?

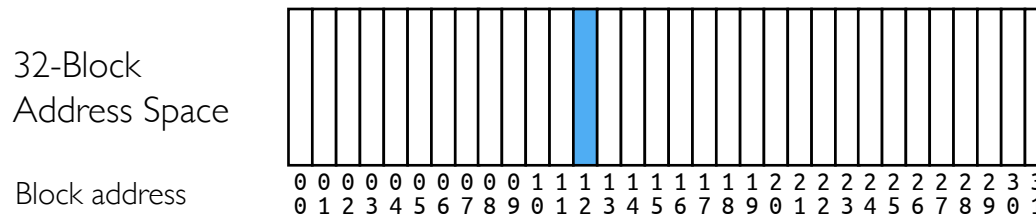

Direct-mapped

Block 12 can go only into block 4
($12 \bmod 8$)

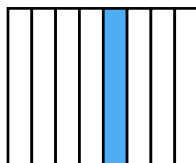

Set number

0 1 2 3 4 5 6 7

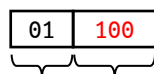

Tag Index

2-way set-associative

Block 12 can go anywhere in set 0
($12 \bmod 4$)

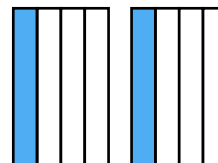

0 1 2 3 0 1 2 3

First Block Second Block

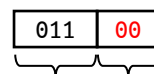

Tag Index

Fully-associative

Block 12 can go anywhere

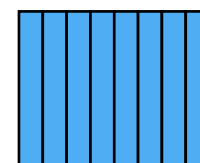

0 0 0 0 0 0 0 0

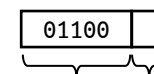

Tag Index

How is Block Found in Cache?

Memory address



- **Byte select** field used to select data within block
 - Offset of byte in block
- **Cache index** used to lookup candidate blocks in cache
 - Index identifies set
- **Cache tag** used to identify actual copy among candidate blocks
 - If no candidate matches, then declare cache miss

Direct-mapped Cache

- Direct-mapped 2^N byte cache with block size of 2^M bytes
 - Uppermost $(32 - N)$ bits of address are **cache tag**
 - Lowest M bits are **byte select**, rest are **cache index**
- Example: 1KiB direct-mapped cache with 32B blocks
 - $\log_2 32 = 5$ bits for byte select, $32 - \log_2 1024 = 22$ bits for cache tag
 - $32 - 5 - 22 = 5$ bits for cache index

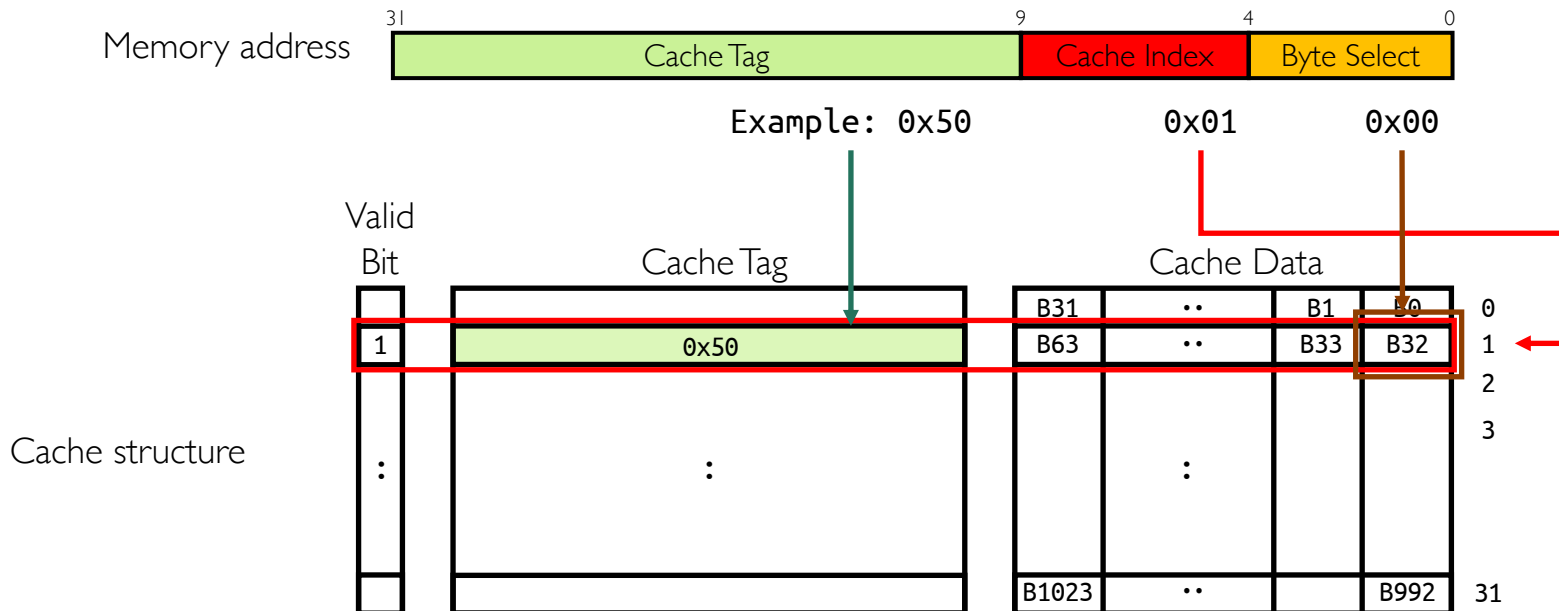

Set-associative Cache

- 2^K -way set-associative 2^N **byte** cache with block size of 2^M **bytes**
 - Lowest M **bits** for byte select, $(32 - N + K)$ **bits** for cache tag, rest for cache index
 - 2^K direct-mapped caches operates in parallel
- Previous example, now with 2-way set-associativity
 - Cache Index selects “set” from cache, there are 16 sets \Rightarrow **4 bits** for index

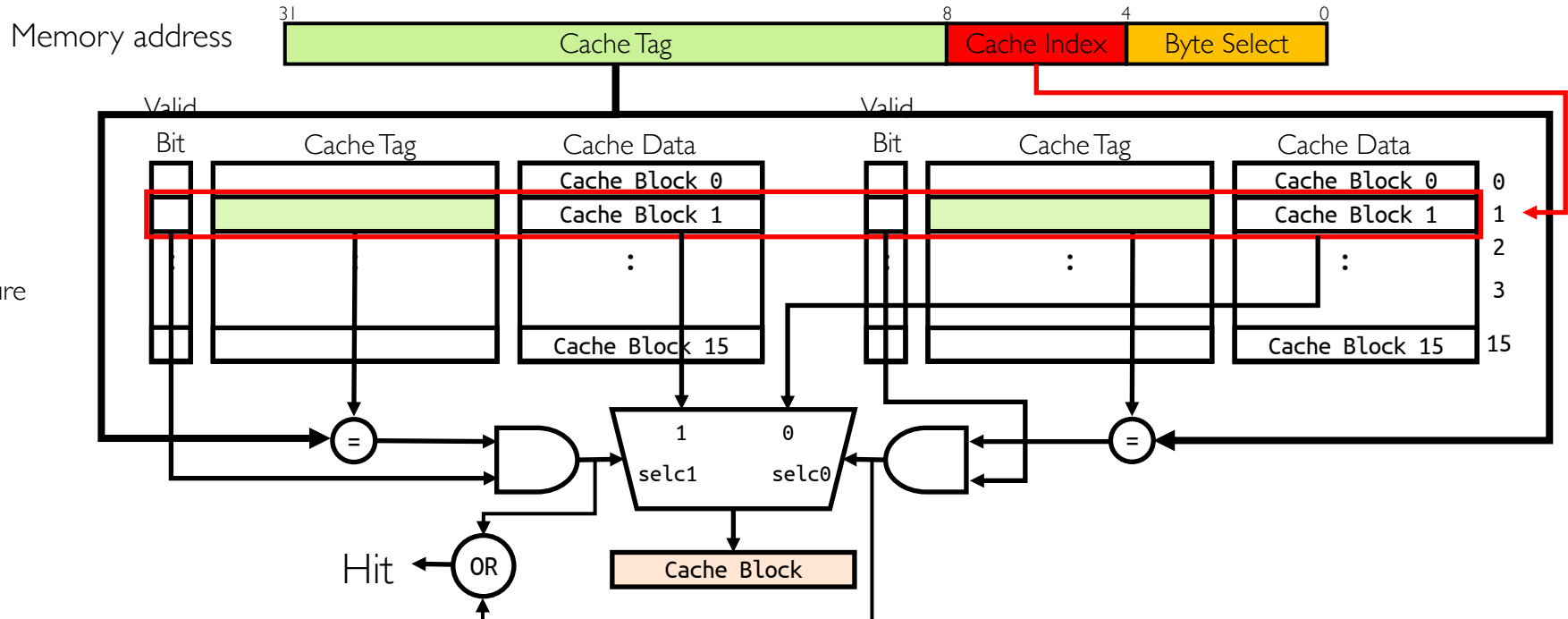

Fully-associative Cache

- Every cache block can hold any memory block
 - Address does not include cache index
 - Compare cache tags of all cache blocks in parallel
- Previous example now with fully-associative cache

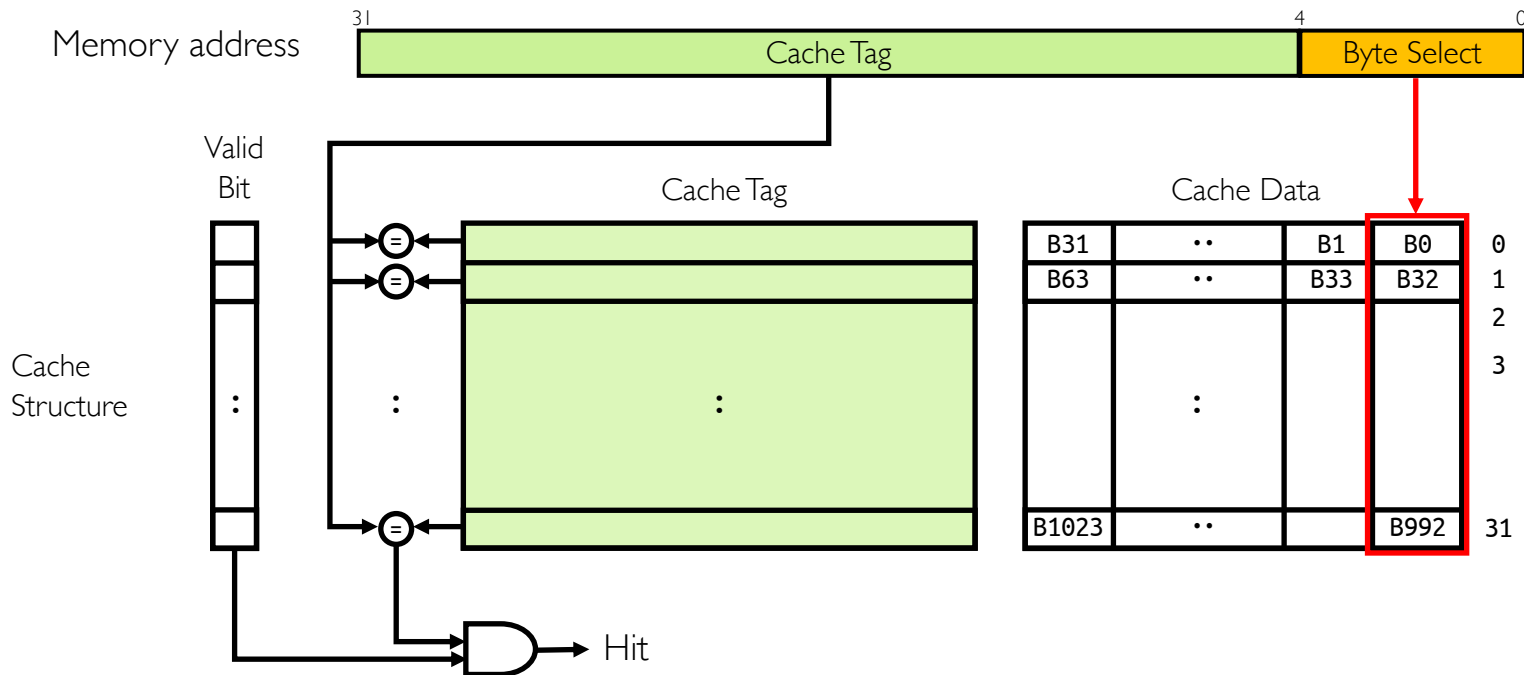

Effective Cache

- Consider 2-MiB, 8-way-set-associative cache and 4KiB physical pages
- Suppose HW uses low-order bits of physical address to index cache
- Suppose process A is allocated physical pages that are separated by 256KiB
- How much cache capacity process A can effectively use?
 - Bytes in memory that are separated by 256KiB are mapped to same cache set
 - A will only be able to use 32KiB (4KiB pages times 8-way set associativity)
 - A can only use less than 2% of cache!



Page Coloring

- Physical pages are given colors
- Pages with same color will be mapped to the same set in cache
 - In above example, there will be 64 different colors (256KiB divided by 4KiB pages)
- Kernel maps sequential virtual pages to physical pages with different colors
 - Sequential pages in virtual memory do not contend for the same cache set

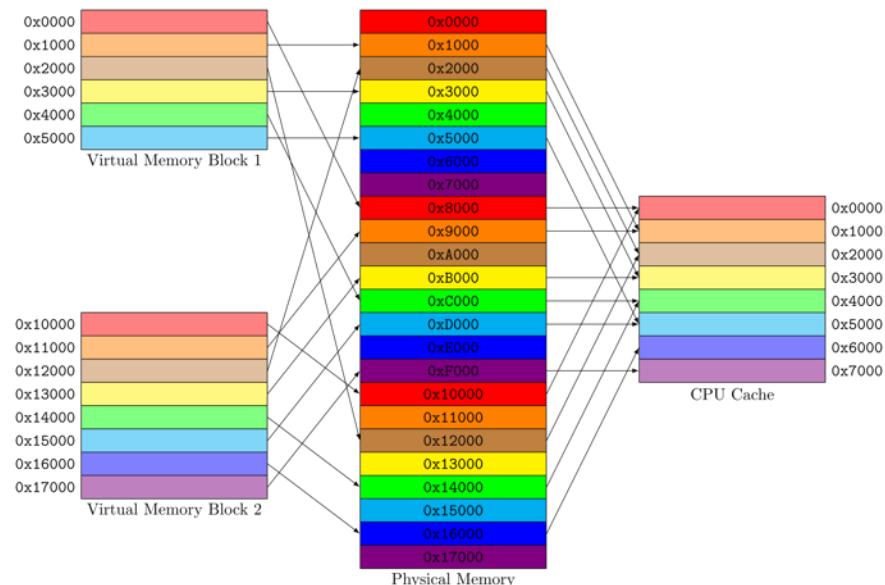

Possible Sources of Cache Misses

- **Compulsory (cold)**
 - Cache hasn't seen this block before (start or migration of process)
 - "Cold" fact of life: not whole lot you can do about it
- **Capacity**
 - Cache cannot contain all blocks accessed by program
 - Solution: increase cache size
- **Conflict (collision)**
 - Multiple memory locations mapped to the same cache location
 - Solution 1: increase cache size
 - Solution 2: increase associativity (no conflict misses in fully-associative cache)
- **Coherence (invalidation)**
 - Other process (e.g., I/O) updates memory

Replaced Policy on Cache Miss?

- Easy for direct-mapped: only one possibility
- For set-associative or fully-associative
 - Random
 - Least Recently Used (LRU, more on this later)

What Happens on Write?

- **Write-through**: write to both cache and lower-level memory
 - + Read misses cannot result in writes
 - – Processor held up on writes unless writes are buffered
- **Write-back**: write only to cache
 - Modified cache block is marked dirty
 - On replacement, dirty block is written to lower-level memory
 - + Repeated writes are not sent to DRAM
 - + Processor not held up on writes
 - – More complex
 - – Read miss may require writeback of dirty data

Caching Address Translations

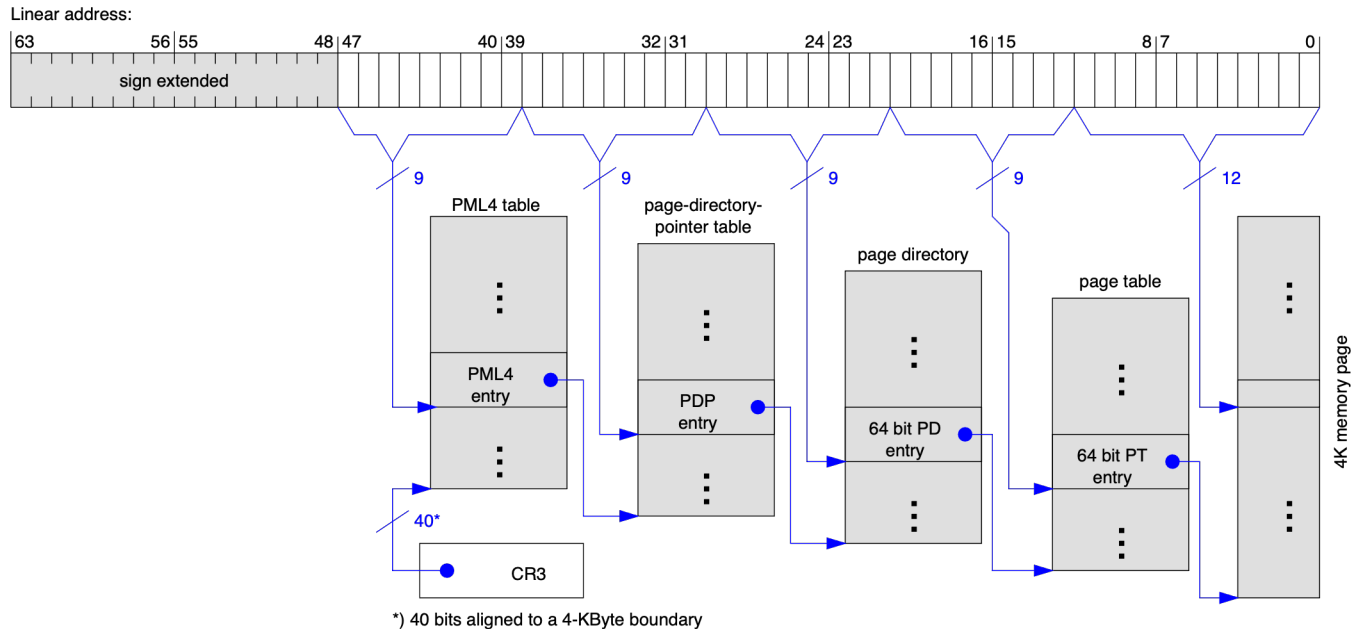

- Cannot afford to translate on every access
 - At least five DRAM accesses per actual DRAM access
 - Or: perhaps I/O if page table partially resides on disk!
 - Even worse, what if we use caches to make memory access faster than DRAM access?

Recall: Memory Hierarchy

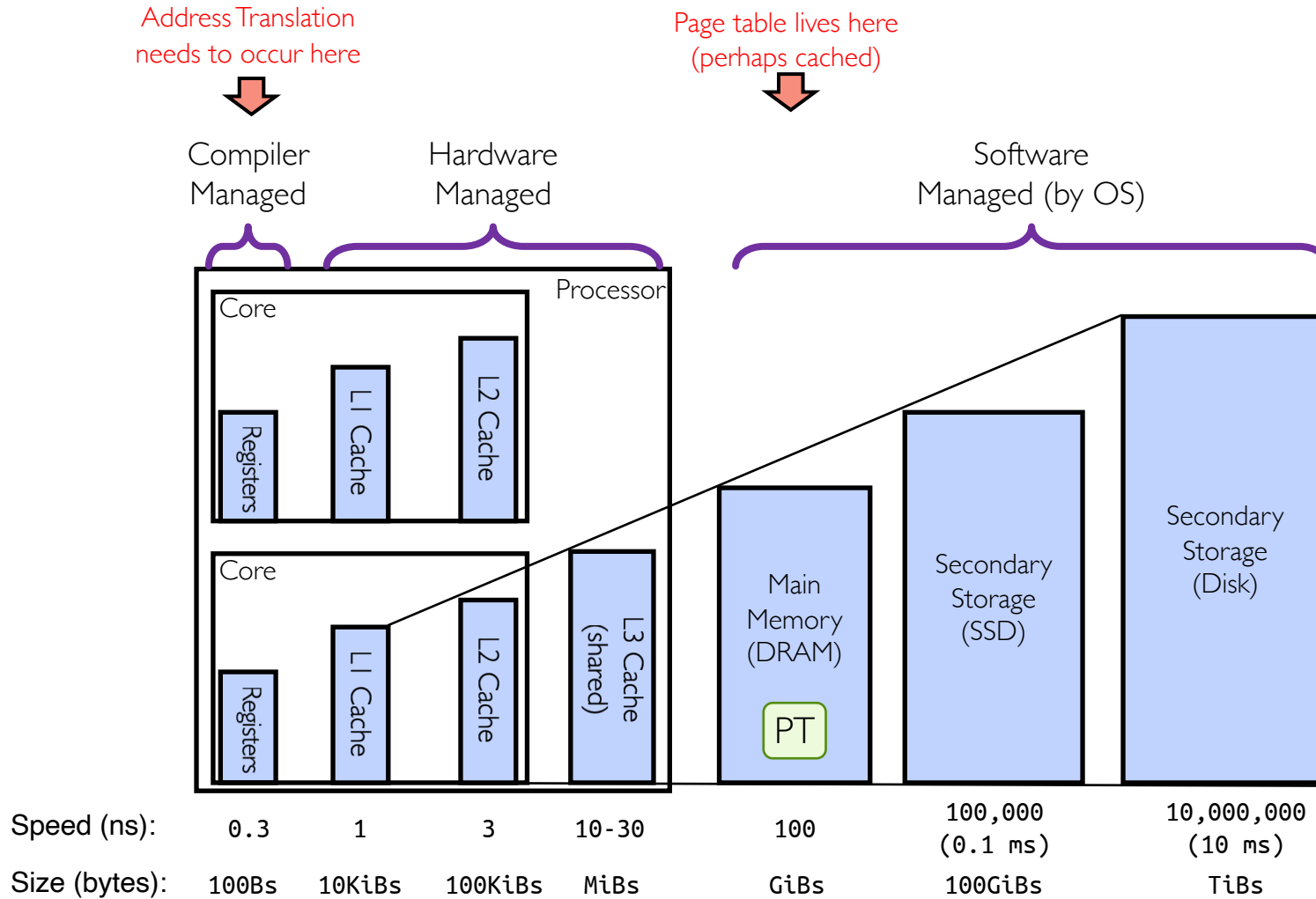

Translation Lookaside Buffer (TLB)

- Main idea: cache recent virtual page number to physical page number translations
- TLB hit provides physical address without reading any of page tables!
 - Caches end-to-end result
 - Even if translation involved multiple levels
- Does page locality exist?
 - Instruction accesses: sequential accesses \Rightarrow Frequent accesses to the same page \Rightarrow Yes!
 - Stack accesses: definite locality of reference \Rightarrow Yes!
 - Data accesses: less page locality, but still some \Rightarrow Yes, so so!

TLB: Caching Applied to Address Translation

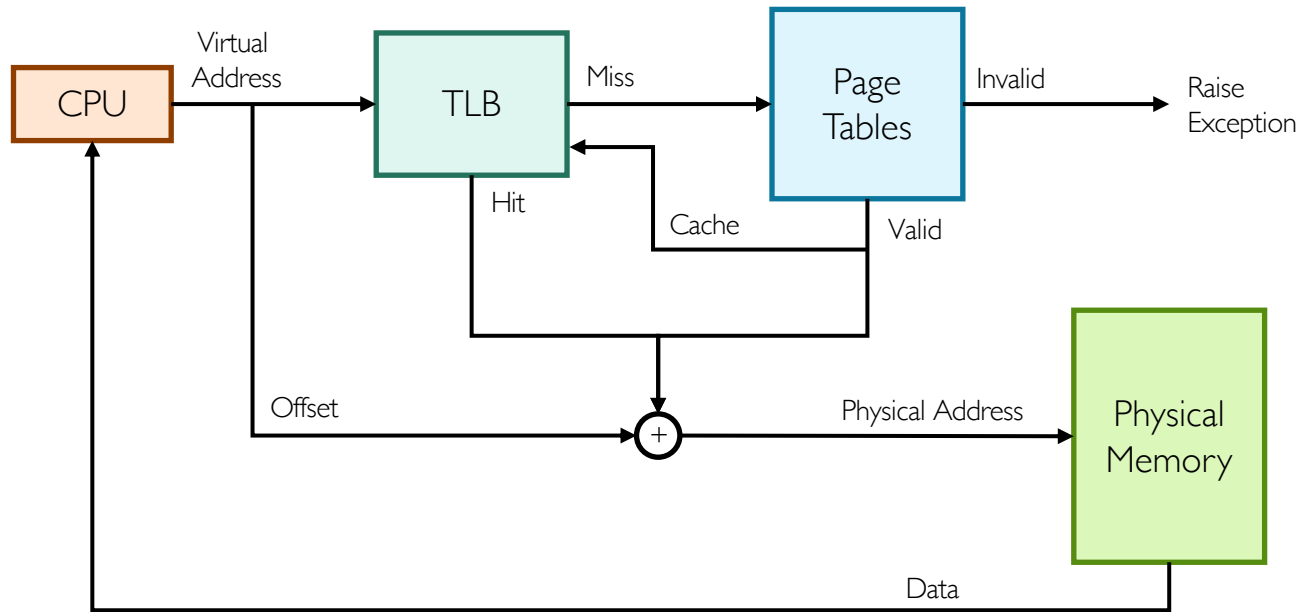

TLB Consistency with PTEs

- If PTE permission is **reduced**: TLB entry should be invalidated
 - Early computers discarded entire TLB
 - Modern architectures allow removal of individual entries
- If PTE permission is **added**: nothing needs to be done
 - E.g., changing invalid to read-only or read-only to read-write
 - Any reference would cause exception, OS removes TLB entry
- If PTE is **invalidated**: TLB entry should be invalidated too
 - E.g., swapping out page from memory to disk (more on this later)

Accessed and Dirty Bits

- TLB entries generally don't have **accessed bit**
 - If address is cached in TLB, it already should have been accessed
 - Page-table walk sets accessed bit of PTE on TLB miss
- TLB entries do have **dirty bit**
 - When write misses in TLB, page-table walk sets dirty bit in PTE and TLB
 - Even when write hits in TLB, page-table walk **is necessary** to set dirty bit if it isn't set
 - If dirty bit is set in TLB, no page-table walk is necessary (saving memory bandwidth)
- Do we really need dirty bit in PTE and TLB?
 - No! OS can emulate it (e.g., BSD Unix)
 - Initially, mark all pages as read-only
 - On write, trap to OS, set software dirty bit, and mark page as read-write
- Do we really need access bit in PTE?
 - No! OS can emulate it
 - Initially, mark all pages as invalid
 - On read, trap to OS (invalid), set software access bit, and mark page read-only
 - On write, trap to OS (invalid or read-only), set software access and dirty bits, mark page read-write

Homonyms

- Definition: single virtual address mapped to different physical addresses
- Problem: TLB entries are invalid *after context switching* to another process
- Solution 1: *invalidate* all TLB entries
 - + Simple
 - – Expensive (what if switching frequently between processes)
- Solution 2: *tag* each TLB entry with *process-context identifier (PCID)*
 - + Less expensive
 - – Needs extra hardware

TLB Shutdown

	Process ID	VirtualPage	PageFrame	Access	
Processor 1 TLB	=	0	0x0053	0x0003	R/W
	=	1	0x40FF	0x0012	R/W
Processor 2 TLB	=	0	0x0053	0x0003	R/W
	=	0	0x0001	0x0005	Read
Processor 3 TLB	=	1	0x40FF	0x0012	R/W
	=	0	0x0001	0x0005	Read

- If processor 1 updates process 0's PTE for page **0x53**, then it should
 - Remove old entry from its TLB
 - Send **inter-processor interrupt** to other processors telling them to remove their old entries
- **Shutdown** is complete once all processors verify that their old entry is removed
- TLB shutdown overhead increases linearly with number of processors

What Happens on TLB Miss?

- Hardware-traversed page tables
 - On TLB miss, hardware walks through current page tables to fill TLB (could be multiple levels)
 - Valid PTE: Hardware fills TLB and processor never notices
 - Invalid PTE: CPU raises **page fault** ⇒ Kernel decides what to do next
- Software-traversed page tables
 - On TLB miss, CPU raises TLB fault
 - Kernel walks through page table(s) to find PTE
 - Valid PTE: Fills TLB and returns from fault
 - Invalid, internally calls **page fault handler**

TLB Fault and Page Fault Exceptions

- Unlike interrupts, exceptions are **synchronous**, caused by particular instruction
 - E.g., TLB fault or page fault, divide by zero
- In general, faulting instruction needs to be **restarted** after exception is handled
- Side effects of faulting instruction need to be undone
 - Example: `push 10`
 - What if page fault occurs when write to stack pointer?
 - Was `sp` incremented before or after page fault?
- **Partially executed** instructions should also be undone in out-of-order execution
 - Example 1: `mul r1, r2, r3`
`bne r1, r4, loop`
`ld r5, (r6)`
 - What if it take many cycles to see if `r1 = r4`, but load has already caused page fault?
 - Example 2: `div r1, r2, r3`
`ld r4, (r5)`
 - What if it takes many cycles to discover divide-by-zero, but load has already caused page fault?

Precise Exceptions

- Instructions retire when their results become visible in architectural state
 - E.g., processor registers, memory, etc.
 - Architectural state \neq micro-architectural state (e.g., caches)
- To implement precise exceptions, instructions should retire in program's sequential order
 - Execution could still be out-of-order
- Exception should only be raised when faulting instruction tries to retire
 - All instructions before faulting instruction should have already retired
- When exception is raised, architectural state should be preserved
 - Faulting instruction and all following instructions act as if they have not even started

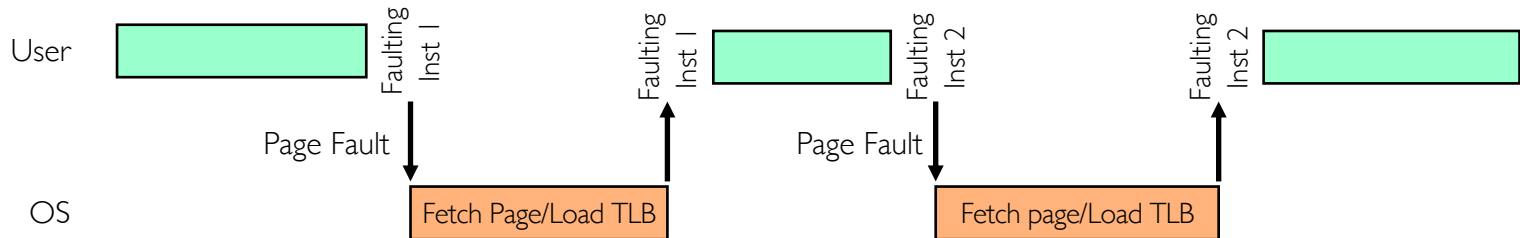

Improve Efficiency Even More!

- TLB improves performance by caching recent translations
- How to improve performance even more?
 - Multi-level TLBs
- What is the cost of first-level TLB miss?
 - Second-level TLB lookup
- What is the cost of second-level TLB miss?
 - x86: 2-4 level page table walk

Virtually-addressed Cache

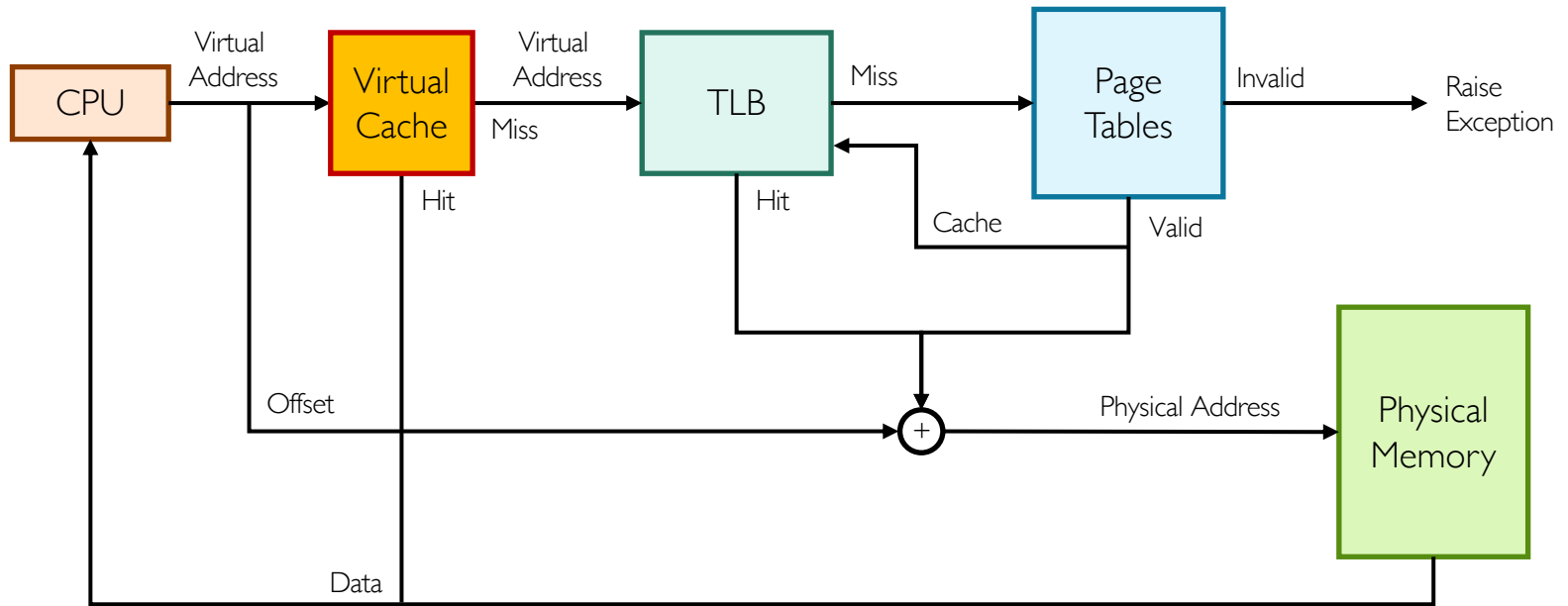

- Too slow to access TLB before looking up address in memory
- Instead, add virtually-addressed cache (virtual cache)
- In parallel, access TLB to generate physical address in case of cache miss

Synonym

- Definition: different virtual addresses mapped to same physical address
 - Could be in same virtual address space or different virtual address spaces
 - E.g., `mmap()` same file multiple times in same process or once in multiple processes
- **Aliasing** problem: synonyms could be mapped to different locations in virtual cache
- Typical solution: **virtually-indexed-physically-tagged** virtual cache
 - Map synonyms to the same cache set (kernel ensures assigned VAs agree in index bits)
 - Tag each virtual cache block by physical address
 - Lookup virtual cache and TLB in parallel
 - Update/invalidate other copies if physical address from TLB matches multiple entries
- Synonym problem could affect **any** HW structure that deals with memory accesses
 - E.g., load with synonym VA misses in **store buffer** if entries are tagged by VA and PID

Aside: Memory-mapped Files

- Traditional I/O involves explicit transfers between buffers in process address space to/from regions of file
 - This involves multiple copies into caches in memory, plus system calls
- OS can map region of file into empty region of process address space
 - Implicitly *page it in* when we read it
 - Write it and eventually *page it out*
- Executable files are treated this way when we **exec** the process

Putting it Together: Address Translation

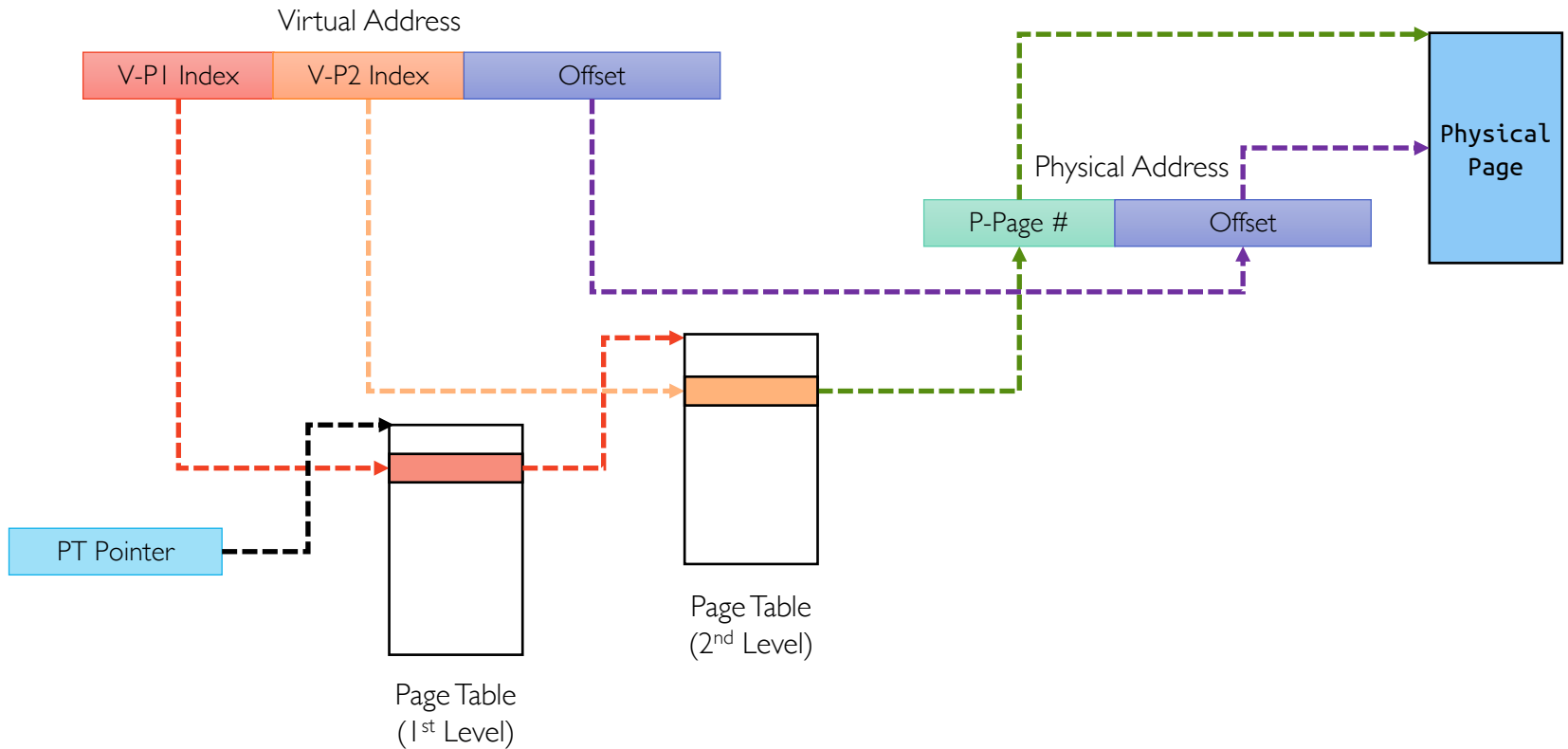

Putting it Together: TLB

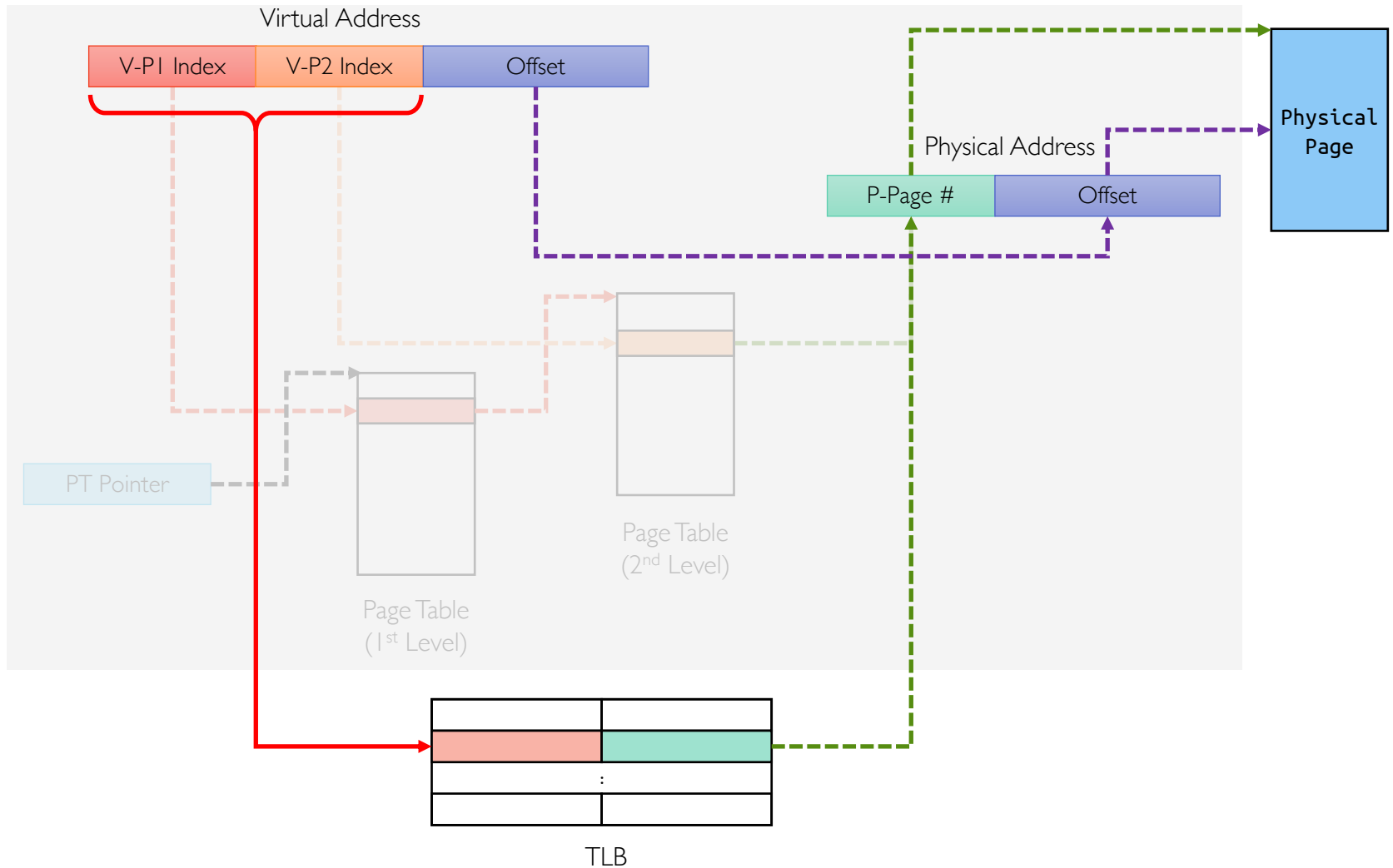

Putting it Together: Physical Cache

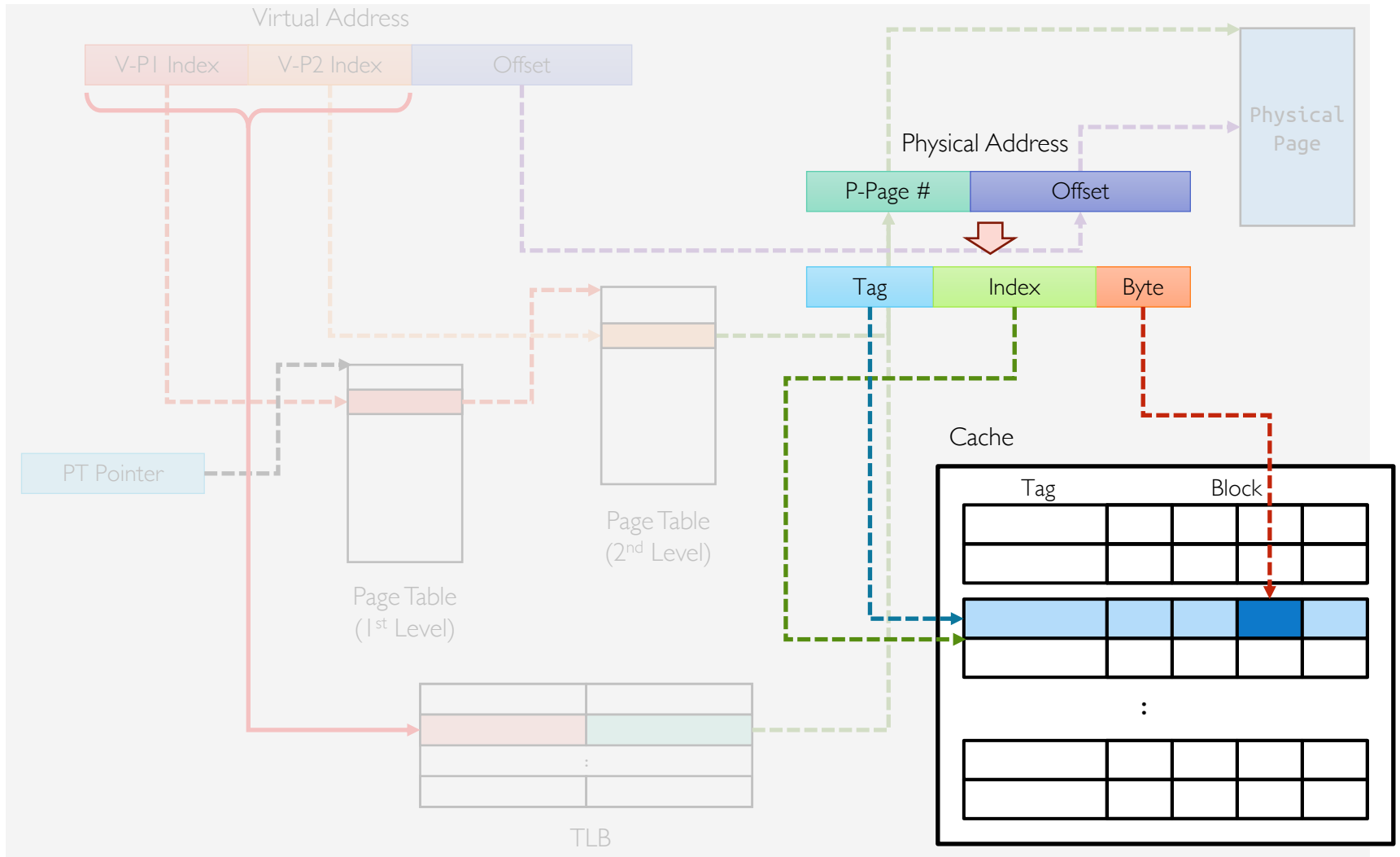

Putting it Together: Page Table, TLB, and Caches

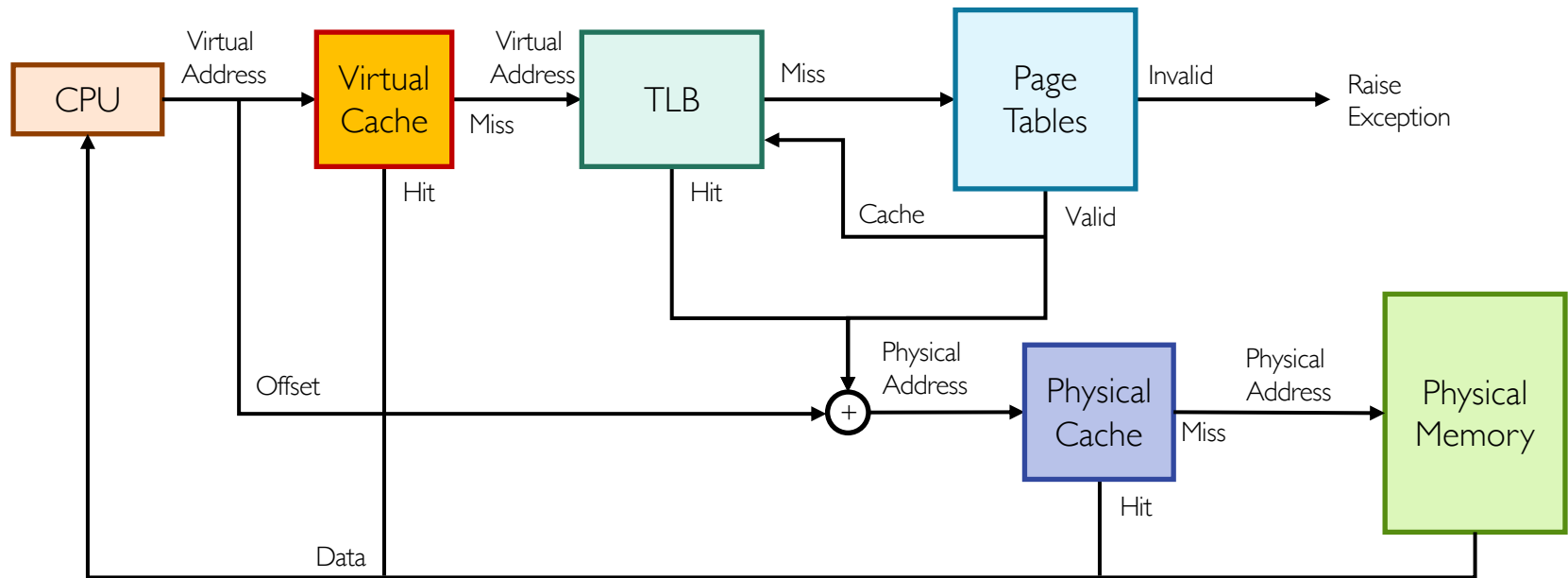

Recall: Memory Hierarchy

- Can TLB misses get resolved without ever going to main memory?

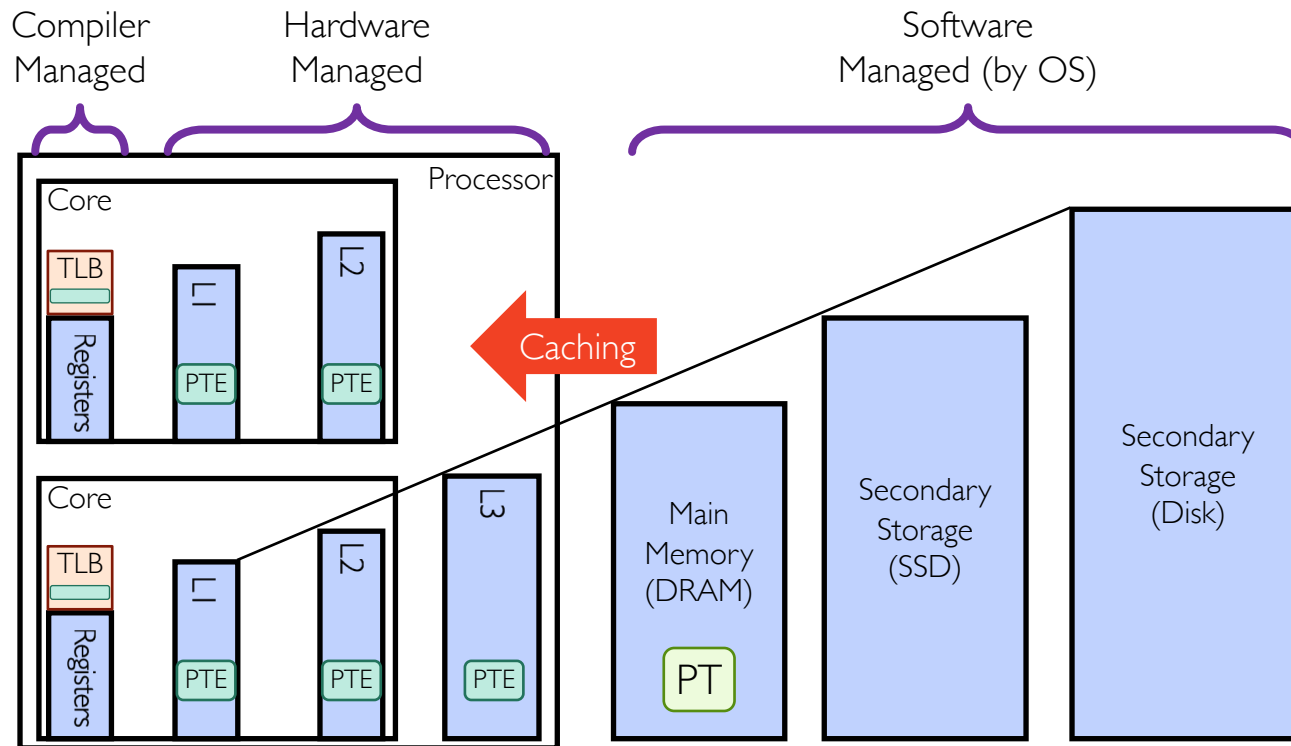

TLB Set Associativity

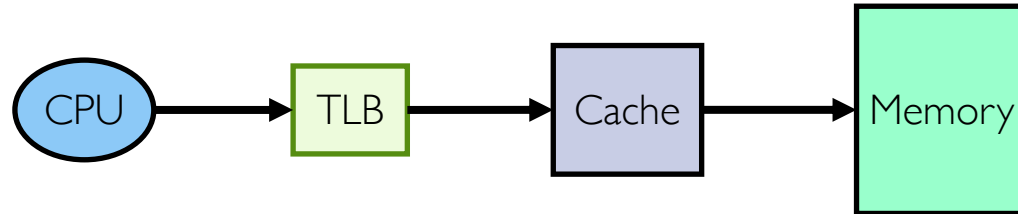

Average memory access time = $\text{hit-time}_{\text{TLB}} + (\text{miss-ratio}_{\text{TLB}} \times \text{miss-time}_{\text{TLB}})$

- TLB hit time is added to all memory accesses
- Should TLB be direct-mapped or have low associativity?
 - No! TLB needs to have very few conflicts!
 - Miss time is extremely high!
- TLBs are typically fully-associative
 - Significantly reduce conflict misses in return for slightly higher hit time

Do TLBs Always Improve Performance?

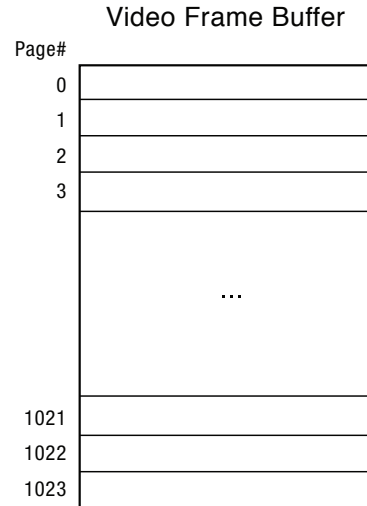

- Example: for HD displays, video frame buffer could be large
 - E.g., 4k display: $32 \text{ bits} \times 4\text{K} \times 3\text{K} = 48\text{MiB}$ (spans 12K of 4KiB pages)
- Even large on-chip TLB with 256 entries cannot cover entire display
- Each horizontal line of pixels could be on on page
- Drawing vertical line could require loading a new TLB entry

Superpages: Improving TLB Hit Rate

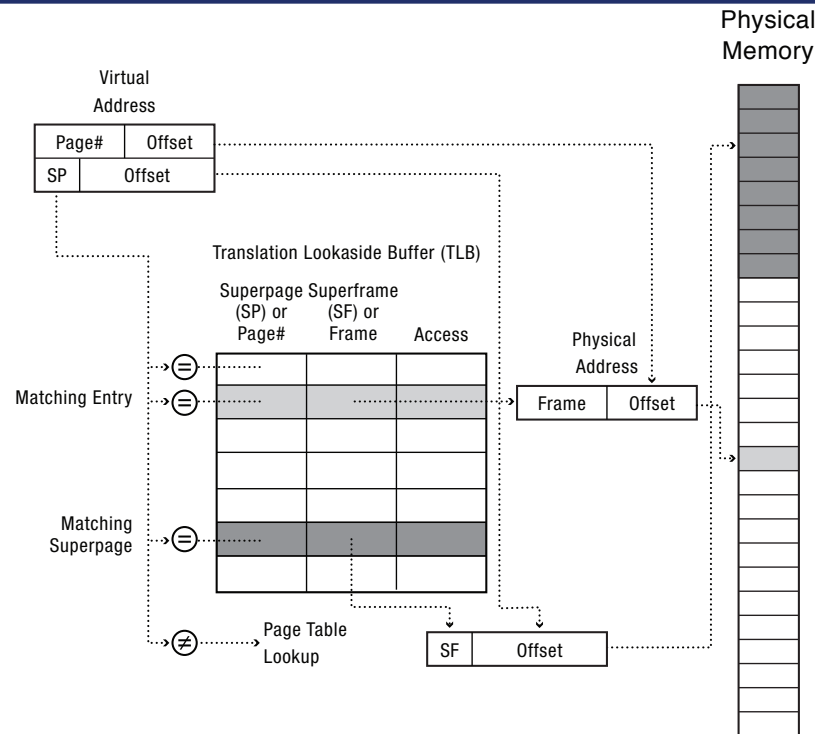

- Reduce number of TLB entries for large, contiguous regions of memory
 - Represent 2 adjacent 4KB pages by single 8KB **superpage**
- By setting a flag, TLB entry can be a page or a superpage
 - E.g., in x86: 4KB (12 bits offset), 2MB (21 bits offset), or 1GB (30 bits offset)

Linux Virtual Memory Map Prior to KPTI Patch

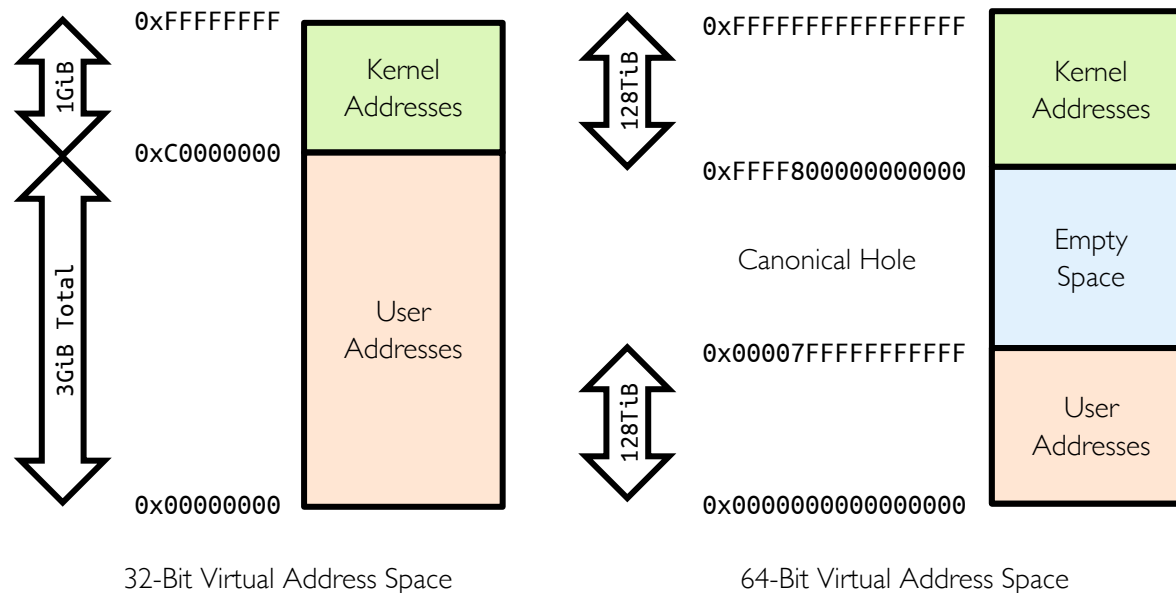

- Address space of user process includes kernel memory
- Kernel memory is protected from user process by *owner bit*
- + On system calls or interrupts, kernel page tables are always present
 - Mitigating context-switch overheads (e.g., TLB flush, page-table swapping, etc.)
- – It exposes serious security vulnerabilities that have been exploited by various attacks
 - E.g. Meltdown and Spectre attacks

Meltdown Attack: Background



- Branches can significantly slow down **out-of-order execution**
 - E.g., processor has to wait for many cycles to determine direction of conditional jump
- To speed up out-of-order execution, modern processors implement **branch predictors (BP)**
 - BP predicts whether conditional branch will be taken **before its execution**
 - Predictions are usually based on previous executions of the branch
 - Processor executes next instructions speculatively
 - On branch misprediction, processor **rolls back** speculatively-executed instructions
 - Their results do not change architectural state

Meltdown Attack

- Meltdown was announced in 2018
- It affects Intel x86, IBM Power, and some ARM processors

```
char array[256 * 4096]; // Skip 4096 to avoid HW cache prefetch
flush_cache(array);    // Make sure array is not cached
try {                  // catch and ignore SIGSEGV (illegal access)
    char result = *(char *)kernel_address; // Segmentation fault
    char dummy = array[result * 4096];    // Leak info!
} catch({;})          // Could use signal() to catch SIGSEGV
for (int i = 0; i < 256; i++)
    if (is_in_cache(array[i * 4096]))
        printf("%d\n"); // found byte at kernel_address
```

- Kernel page-table isolation (KPTI) patch was released to mitigate Meltdown
 - Without PCID tag in TLB, KPTI needs to flush TLB twice on syscall and interrupts (800% overhead!)
 - Need at least kernel v4.14 which utilizes PCID tag in new HW to avoid flushing

Summary

- Principle of locality
 - Programs access small portion of address space at any instant of time
- Cache organizations
 - Direct-mapped, set-associative, fully-associative
- Three (+ 1) major categories of cache misses
 - Compulsory, conflict, capacity, coherence
- TLB: caching applied to address translations
 - Cache relatively small number of PTEs
 - Fully-associative (since conflict misses expensive)
 - On TLB miss, page table is traversed and if PTE is invalid, cause page fault
 - On change in page table, TLB entries must be invalidated

Questions?

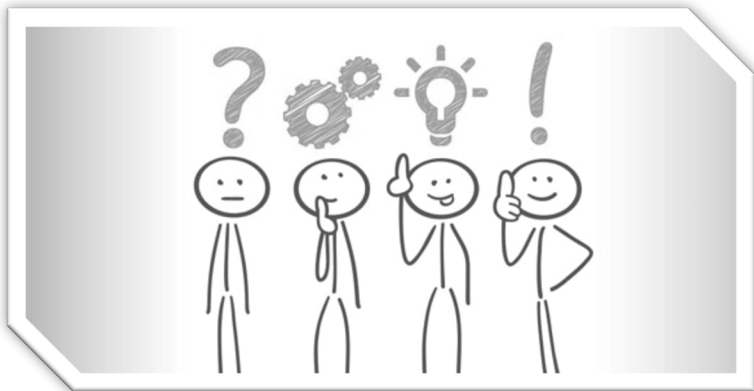

Acknowledgment

- Slides by courtesy of Anderson, Ousterhout, Sorin, Asanovic, Culler, Stoica, Silberschatz, Joseph, and Canny