

USB to UART – CH342

Pull CH342_EN low or close jumper to isolate the CH342 and allow full access to the UART breakout pins

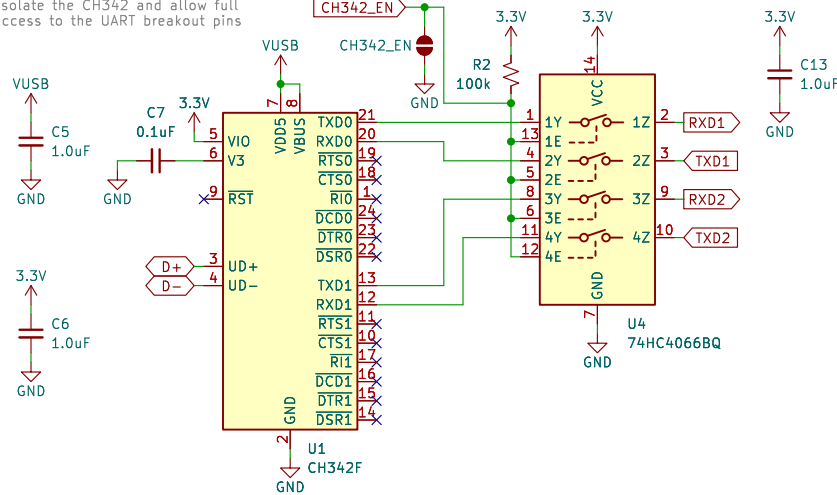

USB

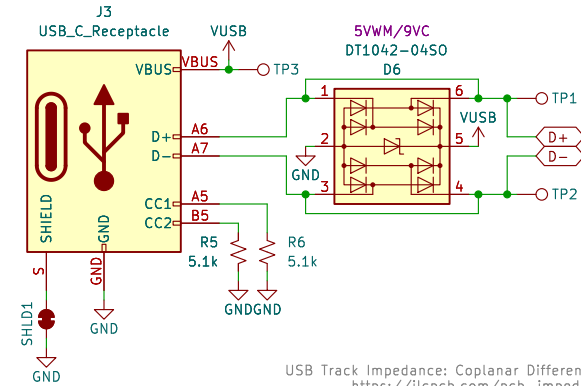

USB Track Impedance: Coplanar Differential Pair @ 90Ω
<https://jlcpcb.com/pcb-impedance-calculator>
 Board Thickness: 1.6mm, Layers: 4, Er: 4.4 (7628 Prepreg)
 Dielectric Thickness (Layer 1 to 2): 8.28mil/0.21mm (JLC7628)
 Copper Thickness (1oz outer / 0.5oz inner): 1.38mil/0.035mm
 Polygon Isolation: 7mil/0.1778mm
 Trace Spacing: 9.07mil/0.2304mm
 Trace Width: 10.93mil/0.2776mm
 Trace center-to-center: 20.0mil/0.508mm

IMU – IM19

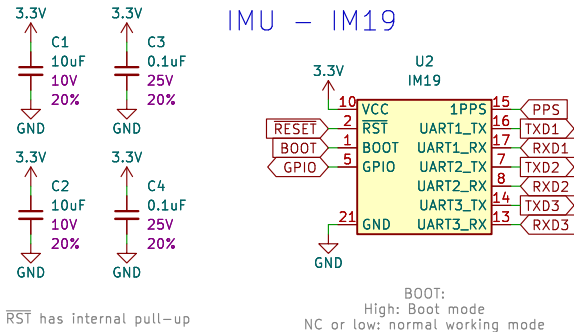

Locking JST

Modify jumper to select 5V vs. 3.3V on Pin 1. With care, Pin 1 can be used for power output or input.

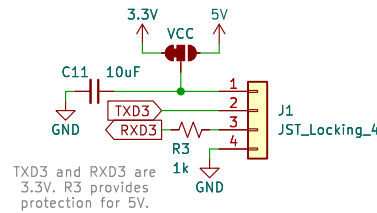

TXD3 and RXD3 are 3.3V. R3 provides protection for 5V.

Breakouts

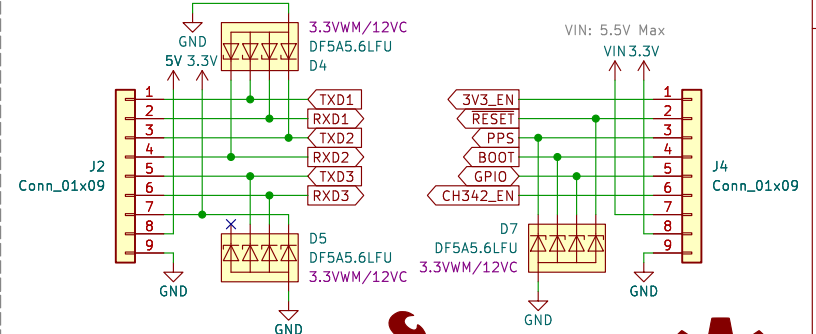

Power Mux

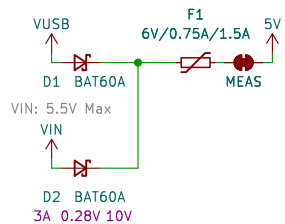

Voltage Regulation – RT9080–3.3

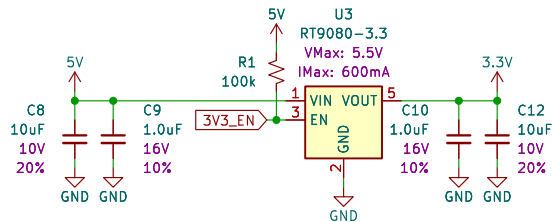

LED

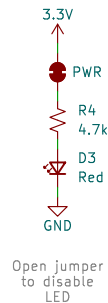

Designed by: P.C.
SparkFun Electronics
 Sheet: /
 File: SparkFun_IM19_IMU_Breakout.kicad_sch

Title: SparkFun IM19 IMU Breakout

Size: USLetter Date: 2025-10-29
 KiCad E.D.A. 9.0.6-rc2

Rev: v10
 Id: 1/1