

NUTPLATE ATTACHED BY ADHESIVE APPLIED TO THIS SURFACE.

DISPOSABLE ELASTIC FIXTURE HOLDS NUTPLATE WHILE ADHESIVE CURES.

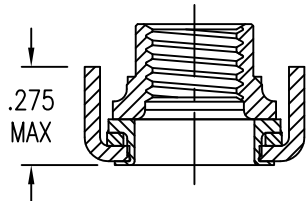

NUT MAY BE REMOVED FROM RETAINER AND REPLACED. THREAD LOCK PER NASM25027. DRI-FILM LUBE ON NUT PER AS5272.

NUTPLATE MEETS THE STRENGTH REQUIREMENTS OF NASM25027.

ALL DIMENSIONS BEFORE PAINT.

MINIMUM NUT HEIGHT H LIMITED BY STRENGTH REQUIREMENTS ONLY.

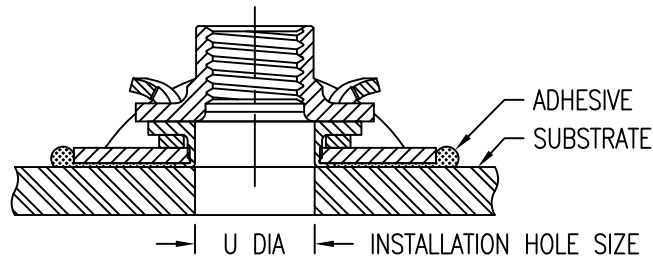

NUT AND RETAINER MATERIAL AND FINISH DATA

CODE	NUT MATERIAL	SPEC.	PASSIVATE	RETAINER MATERIAL	SPEC.	PASSIVATE
CR	A-286 CRES	AMS 5525	AMS 2700	A-286, 304, 305 CRES	AMS 5525, 5513, 5514	AMS 2700
CRA	A-286 CRES	AMS 5525	AMS 2700	A-286, 304, 305 CRES	AMS 5525, 5513, 5514	AMS 2700

BASEPLATE MATERIAL AND FINISH DATA

CODE	MATERIAL	SPEC.	FINISH	SPEC.
A	5052 ALUMINUM	AMS 4016	NONE	
AA	5052 ALUMINUM	AMS 4016	ANODIZE	MIL-A-8625 TYPE I
CR	304 CRES OR A-286 CRES	AMS 5513 OR AMS 5525	PASSIVATE	AMS 2700
CRA	A-286 CRES	AMS 5525	PASSIVATE	AMS 2700

THREAD DATA

CODE	THREAD SIZE
4	.2500-28 UNJF-3B
420	.2500-20 UNJC-3B

NUT HEIGHT AND THREAD RELIEF DIMENSIONS

CODE	NONE	2	3	4	5	6
R ±.025	.150	.235	.298	.361	.424	.488
H ±.025	.362	.424	.487	.549	.609	.672

INSTALLATION HOLE SIZE

CODE	U DIA
4	.250-.312
420	.250-.312

EXAMPLE PART NUMBER

CB3009 A 4 CRA 2 P

NOTE: FOR NON-LOCKING NUT ADD "NL" SUFFIX TO PART NUMBER.

OPTIONAL MIL-PRF-85582 BASEPLATE PRIMER
 THREAD RELIEF CODE - 2
 NUT AND RETAINER MATERIAL - A-286, 304, AND 305 CRES
 THREAD SIZE - .2500-28 UNJF-3B
 BASEPLATE MATERIAL - ALUMINUM
 BASIC PART NUMBER

UNLESS OTHERWISE SPECIFIED, ALL DIMENSIONS ARE IN INCHES AND TOLERANCES ARE AS SHOWN BELOW. DIMENSIONAL TOLERANCES AND SYMBOLS PER ANSI Y14.5M-1982.

PROPRIETARY PARTS SHOWN IN THIS DRAWING ARE THE SUBJECT OF ISSUED UNITED STATES AND FOREIGN PATENTS AND PATENTS PENDING. UNAUTHORIZED REPRODUCTION AND/OR DISTRIBUTION OF THIS DRAWING IS SPECIFICALLY PROHIBITED.

CLICK BOND

CARSON CITY
NEVADA 89706

CAD CB3009-1

APPROVALS	DATE
DRAWN <i>DAC</i>	5DEC13
CHECKED <i>DAC</i>	5DEC13
RELEASED <i>DAC</i>	5DEC13
REVISED <i>DAC</i>	5DEC13

TITLE
NUTPLATE, TWO LUG, ADHESIVE BONDED

SIZE	CAGE CODE	DWG. NO.	REV.
A	66530	CB3009	15
SCALE	2/1	5DEC13	SHEET 1 OF 2

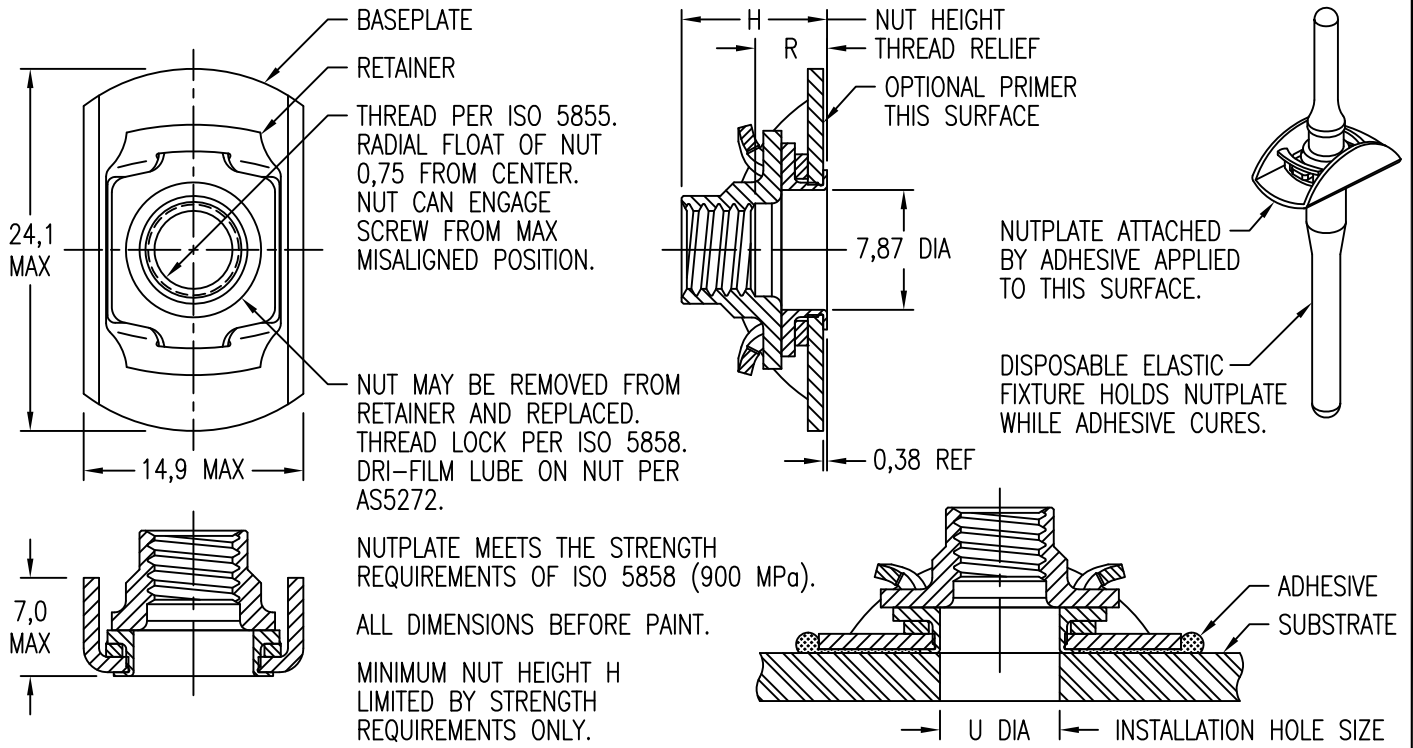

NUT AND RETAINER MATERIAL AND FINISH DATA

CODE	NUT MATERIAL	SPEC.	PASSIVATE	RETAINER MATERIAL	SPEC.	PASSIVATE
CR	A-286 CRES	AMS 5525	AMS 2700	A-286, 304, 305 CRES	AMS 5525, 5513, 5514	AMS 2700
CRA	A-286 CRES	AMS 5525	AMS 2700	A-286, 304, 305 CRES	AMS 5525, 5513, 5514	AMS 2700

BASEPLATE MATERIAL AND FINISH DATA

CODE	MATERIAL	SPEC.	FINISH	SPEC.
A	5052 ALUMINUM	AMS 4016	NONE	
AA	5052 ALUMINUM	AMS 4016	ANODIZE	MIL-A-8625 TYPE I
CR	304 CRES OR A-286 CRES	AMS 5513 OR AMS 5525	PASSIVATE	AMS 2700
CRA	A-286 CRES	AMS 5525	PASSIVATE	AMS 2700

THREAD DATA

CODE	THREAD SIZE
6M	MJ6 X 1,0 4H5H

NUT HEIGHT AND THREAD RELIEF DIMENSIONS

CODE	NONE	2	3	4	5	6
R ±0,65	3,81	5,97	7,57	9,17	10,77	12,40
H ±0,65	9,19	10,77	12,37	13,94	15,47	17,07

INSTALLATION HOLE SIZE

CODE	U DIA
6M	6,00-7,50

EXAMPLE PART NUMBER

CB3009 A 6M CRA 2 P

NOTE: FOR NON-LOCKING NUT ADD "NL" SUFFIX TO PART NUMBER.

OPTIONAL MIL-PRF-85582 BASEPLATE PRIMER
 THREAD RELIEF CODE - 2
 NUT AND RETAINER MATERIAL - A-286, 304, AND 305 CRES
 THREAD SIZE - MJ6 X 1,0 4H5H
 BASEPLATE MATERIAL - ALUMINUM
 BASIC PART NUMBER

UNLESS OTHERWISE SPECIFIED, ALL DIMENSIONS ARE IN MILLIMETERS AND TOLERANCES ARE AS SHOWN BELOW. DIMENSIONAL TOLERANCES AND SYMBOLS PER ANSI Y14.5M-1982.

PROPRIETARY PARTS SHOWN IN THIS DRAWING ARE THE SUBJECT OF ISSUED UNITED STATES AND FOREIGN PATENTS AND PATENTS PENDING. UNAUTHORIZED REPRODUCTION AND/OR DISTRIBUTION OF THIS DRAWING IS SPECIFICALLY PROHIBITED.



CARSON CITY
NEVADA 89706

CAD CB3009-2 METRIC DIMENSIONS	
ANGLES	±1°
.X	±0,8
.XX	±0,25

APPROVALS	DATE
DRAWN <i>DAC</i>	5DEC13
CHECKED <i>DAC/mtm</i>	5DEC13
RELEASED <i>ABC/ati</i>	5DEC13
REVISED <i>DAC</i>	5DEC13

TITLE NUTPLATE, TWO LUG, ADHESIVE BONDED			
SIZE	CAGE CODE	DWG. NO.	REV.
A	66530	CB3009 (METRIC)	15
SCALE	2/1	5DEC13	SHEET 2 OF 2