

LENGTH L DATA (LENGTH L IN SIXTEENTHS OF AN INCH) L MIN = -8 (.50 INCH), L MAX = -96 (6.00 INCH)

CODE	8	10	12	14	16	18	20	22	24	26	28	30	32
L	.500	.625	.750	.875	1.000	1.125	1.250	1.375	1.500	1.625	1.750	1.875	2.000

MATERIAL AND FINISH DATA

CODE	MATERIAL	SPEC.	FINISH	SPEC.
A	2024 OR 7075	AMS-QQ-A-200, AMS-QQ-A-225, OR AMS-QQ-A-250	NONE	
AA	ALUMINUM		ANODIZE	MIL-A-8625
CR	302, 303, 304 OR A-286 CRES	AMS 5513, 5516, 5636, 5637, 5638, 5639, 5640, 5641, 5647 AMS 5525, 5726, 5731, 5732, 5734, OR 5737	PASSIVATE	AMS 2700
CRA	A-286 CRES	AMS 5525, 5726, 5731, 5732, 5734, OR 5737		
CRM	316 CRES	AMS 5507, 5524, 5648, 5653, OR 5907		

FINE THREAD DATA

CODE	THREAD T PER AS8879
3	.1900-32 UNJF-3A
4	.2500-28 UNJF-3A
5	.3125-24 UNJF-3A
6	.3750-24 UNJF-3A
7	.4375-20 UNJF-3A
8	.5000-20 UNJF-3A

COARSE THREAD DATA

CODE	THREAD T PER FED-STD-H28
324	.190-24 UNC-2A
420	.250-20 UNC-2A
518	.312-18 UNC-2A
616	.375-16 UNC-2A
714	.437-14 UNC-2A
813	.500-13 UNC-2A

OPTIONAL CONSTRUCTION

CODE	MANUFACTURING METHOD
B	ONE PIECE

OPTIONAL BASEPLATE PRIMER

CODE	MATERIAL SPEC.
P	MIL-PRF-85582

EXAMPLE PART NUMBER

CB3200 CRM 3-16 P 125 B

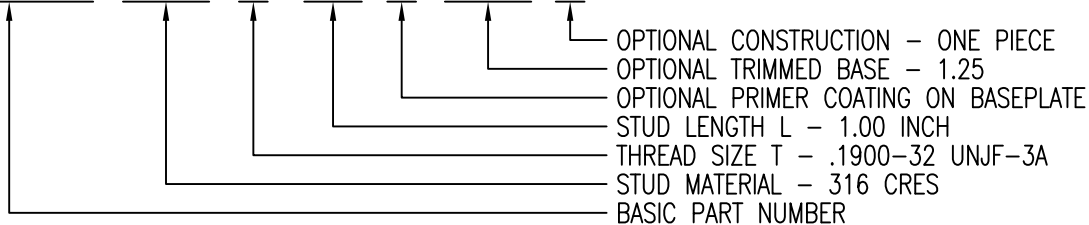

UNLESS OTHERWISE SPECIFIED, ALL DIMENSIONS ARE IN INCHES AND TOLERANCES ARE AS SHOWN BELOW. DIMENSIONAL TOLERANCES AND SYMBOLS PER ANSI Y14.5M-1982.

PROPRIETARY PARTS SHOWN IN THIS DRAWING ARE THE SUBJECT OF ISSUED UNITED STATES AND FOREIGN PATENTS AND PATENTS PENDING. UNAUTHORIZED REPRODUCTION AND/OR DISTRIBUTION OF THIS DRAWING IS SPECIFICALLY PROHIBITED.

CLICK BOND

CARSON CITY
NEVADA 89706

CAD CB3200-1

APPROVALS	DATE
DRAWN RJT	24SEP10
CHECKED <i>JAC</i>	24SEP10
RELEASED <i>ABC</i>	24SEP10
REVISED RJT	24SEP10

TITLE			
STUD, VERY LARGE, ADHESIVE BONDED			
SIZE	CAGE CODE	DWG. NO.	REV.
A	66530	CB3200	5
SCALE	1/1		24SEP10
			SHEET 1 OF 2

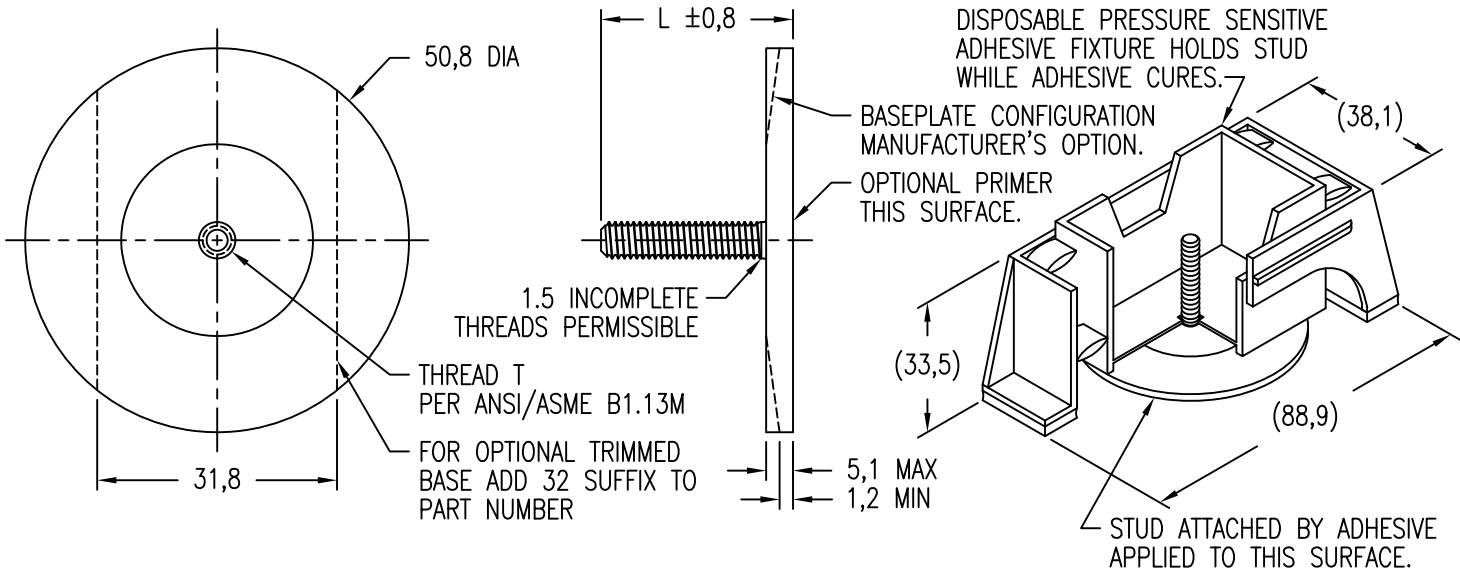

LENGTH L DATA (LENGTH L IN MILLIMETERS) L MIN = 12M (12 mm), L MAX = 150M (150 mm)

CODE	12M	15M	20M	25M	30M	35M	40M	45M	50M
L	12	15	20	25	30	35	40	45	50

MATERIAL AND FINISH DATA

CODE	MATERIAL	SPEC.	FINISH	SPEC.
A	2024 OR 7075	AMS-QQ-A-200, AMS-QQ-A-225, OR AMS-QQ-A-250	NONE	
AA	ALUMINUM		ANODIZE	MIL-A-8625
CR	302, 303, 304 OR A-286 CRES	AMS 5513, 5516, 5636, 5637, 5638, 5639, 5640, 5641, 5647 AMS 5525, 5726, 5731, 5732, 5734, OR 5737	PASSIVATE	AMS 2700
CRA	A-286 CRES	AMS 5525, 5726, 5731, 5732, 5734, OR 5737		
CRM	316 CRES	AMS 5507, 5524, 5648, 5653, OR 5907		

THREAD T DATA

CODE	THREAD SIZE
5M	M5 X 0,8 6g
6M	M6 X 1,0 6g
8M	M8 X 1,25 6g
10M	M10 X 1,50 6g
12M	M12 X 1,75 6g

OPTIONAL CONSTRUCTION

CODE	MANUFACTURING METHOD
B	ONE PIECE

OPTIONAL BASEPLATE PRIMER

CODE	MATERIAL SPEC.
P	MIL-PRF-85582

EXAMPLE PART NUMBER

CB3200 CRM 5M 25M P 32 B

- OPTIONAL CONSTRUCTION - ONE PIECE
- OPTIONAL TRIMMED BASE - 31,8
- OPTIONAL PRIMER COATING ON BASEPLATE
- STUD LENGTH L - 25 mm
- THREAD SIZE T - M5 X 0,8 6g
- STUD MATERIAL - 316 CRES
- BASIC PART NUMBER

UNLESS OTHERWISE SPECIFIED, ALL DIMENSIONS ARE IN MILLIMETERS AND TOLERANCES ARE AS SHOWN BELOW. DIMENSIONAL TOLERANCES AND SYMBOLS PER ANSI Y14.5M-1982.

PROPRIETARY PARTS SHOWN IN THIS DRAWING ARE THE SUBJECT OF ISSUED UNITED STATES AND FOREIGN PATENTS AND PATENTS PENDING. UNAUTHORIZED REPRODUCTION AND/OR DISTRIBUTION OF THIS DRAWING IS SPECIFICALLY PROHIBITED.



CARSON CITY
NEVADA 89706

CAD CB3200-2
METRIC DIMENSIONS

APPROVALS	DATE
DRAWN RJT	24SEP10
CHECKED <i>[Signature]</i>	24SEP10
RELEASED <i>[Signature]</i>	24SEP10
REVISED RJT	24SEP10

TITLE
STUD, VERY LARGE, ADHESIVE BONDED

ANGLES	±1°
.X	±0,8
.XX	±0,25

SIZE	CAGE CODE	DWG. NO.	REV.
A	66530	CB3200 (METRIC)	5
SCALE	1/1	24SEP10	SHEET 2 OF 2