

DISPOSABLE PRESSURE SENSITIVE ADHESIVE FIXTURE HOLDS STANDOFF WHILE ADHESIVE CURES.

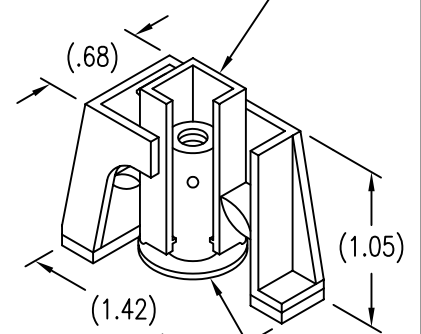
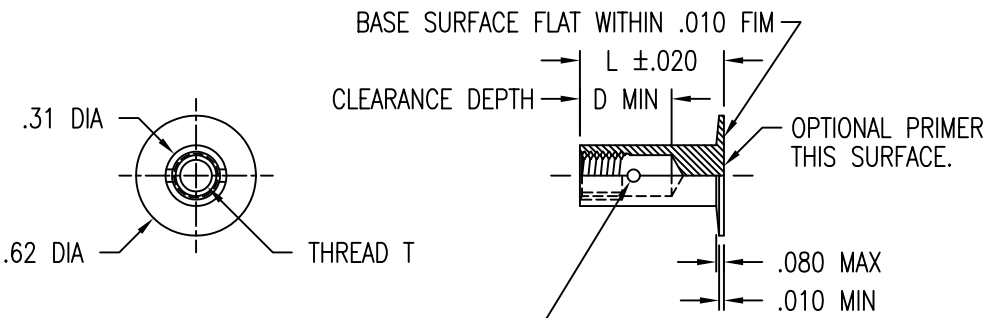

STANDOFF STRAIGHT WITHIN .004 INCH PER INCH OF LENGTH. PITCH DIA CONCENTRIC WITH BASE O.D. WITHIN .020 FIM. PITCH DIA PERPENDICULAR TO BASE WITHIN ±1 DEG.

OPTIONAL INSPECTION HOLE .062 - .070 DIA LOCATED 2 THD PITCHES BELOW INSERT ON -8 AND LONGER PARTS ONLY, PART NUMBER SUFFIX H.

STANDOFF ATTACHED BY ADHESIVE APPLIED TO THIS SURFACE.

LENGTH L DATA (LENGTH L IN SIXTEENTHS OF AN INCH)

CODE	6	7	8	9	10	11	12	13	14	15	16	17	18	20	22	24
L	.375	.437	.500	.562	.625	.687	.750	.812	.875	.937	1.000	1.062	1.125	1.250	1.375	1.500
D MIN	.295		.400		.472											

STANDOFF MATERIAL AND FINISH DATA

CODE	STANDOFF MATERIAL	SPEC.	FINISH	SPEC.
A	2024 OR 6061	QQ-A-200, QQ-A-225, QQ-A-250	NONE	
AA	ALUMINUM		ANODIZE	MIL-A-8625
CR	302, 303, 304 CRES OR A-286 CRES	AMS 5513, 5516, 5636, 5637, 5638, 5639, 5640, 5641, OR 5647 AMS 5525, 5726, 5731, 5732, 5734, OR 5737 (CHEMISTRY ONLY)	PASSIVATE	QQ-P-35
CRA	A-286 CRES	AMS 5525, 5726, 5731, 5732, 5734, OR 5737 (CHEMISTRY ONLY)	PASSIVATE	QQ-P-35
T	6AL-4V TITANIUM	AMS 4911, 4928, 4965, OR 4967	NONE	

OPTIONAL PRIMER

CODE	BASEPLATE PRIMER	SPEC.
P	EPOXY PRIMER	MIL-P-85582
W	FILM PRIMER	CBPS-211

THREAD DATA

CODE	THREAD T
06	.1380-32 UNC-3B
08	.1640-32 UNC-3B
3	.1900-32 UNF-3B

THREAD T

MS21209 OR NAS1130 INSERT. INSERT INSTALLED PER MS33537. LUBE PER MIL-L-46010, TYPE 1. THREAD LOCK PER NASM25027. ACCOMODATES MIL-S-8879 UNJ THREAD SCREW.

EXAMPLE PART NUMBER

CB5001 CRA 3-12 H P

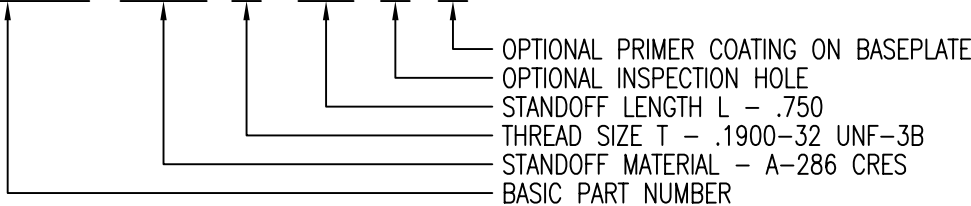

UNLESS OTHERWISE SPECIFIED, ALL DIMENSIONS ARE IN INCHES AND TOLERANCES ARE AS SHOWN BELOW. DIMENSIONAL TOLERANCES AND SYMBOLS PER ANSI Y14.5M-1982.

PROPRIETARY PARTS SHOWN IN THIS DRAWING ARE THE SUBJECT OF ISSUED UNITED STATES AND FOREIGN PATENTS AND PATENTS PENDING. UNAUTHORIZED REPRODUCTION AND/OR DISTRIBUTION OF THIS DRAWING IS SPECIFICALLY PROHIBITED.

GLICK BOND

CARSON CITY
NEVADA 89706

CAD CB5001-1

APPROVALS	DATE
DRAWN BSP	5FEB01
CHECKED DAC	5FEB01
RELEASED CGH	6FEB01
REVISED BSP	5FEB01

TITLE			
STANDOFF, LOCKING THREAD, SMALL BASE			
SIZE	CAGE CODE	DWG. NO.	REV.
A	66530	CB5001	15
SCALE	1/1		5FEB01
SHEET 1 OF 2			

DISPOSABLE PRESSURE SENSITIVE ADHESIVE FIXTURE HOLDS STANDOFF WHILE ADHESIVE CURES.

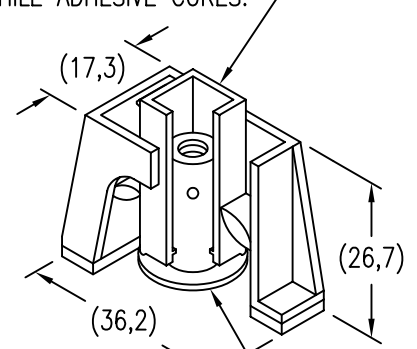
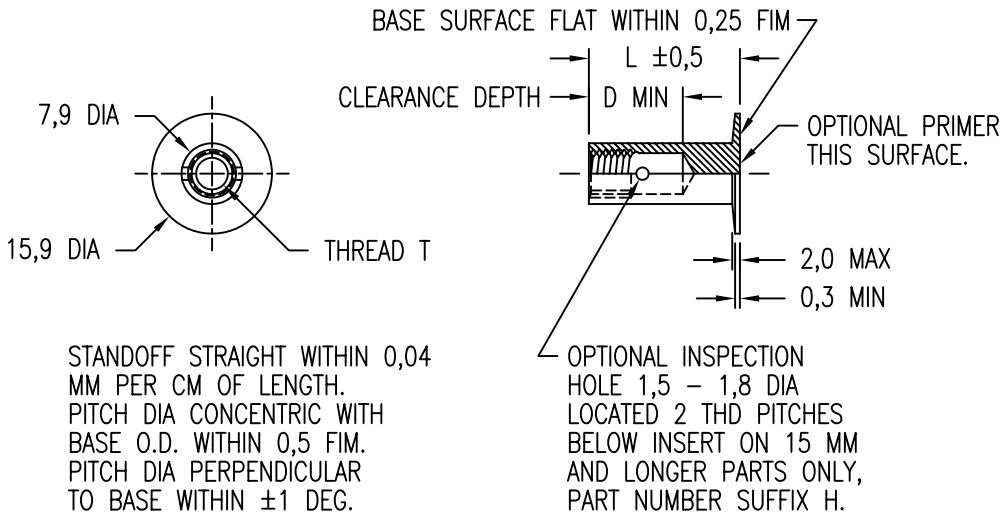

STANDOFF ATTACHED BY ADHESIVE APPLIED TO THIS SURFACE.

LENGTH L DATA (LENGTH L IN MILLIMETERS)

CODE	10M	12M	15M	20M	25M	30M	35M
L	10	12	15	20	25	30	35
D MIN	7,50			12,30			

STANDOFF MATERIAL AND FINISH DATA

CODE	STANDOFF MATERIAL	SPEC.	FINISH	SPEC.
A	2024 OR 6061	QQ-A-200, QQ-A-225, QQ-A-250	NONE	
AA	ALUMINUM		ANODIZE	MIL-A-8625
CR	302, 303, 304 CRES OR A-286 CRES	AMS 5513, 5516, 5636, 5637, 5638, 5639, 5640, 5641, OR 5647 AMS 5525, 5726, 5731, 5732, 5734, OR 5737 (CHEMISTRY ONLY)	PASSIVATE	QQ-P-35
CRA	A-286 CRES	AMS 5525, 5726, 5731, 5732, 5734, OR 5737 (CHEMISTRY ONLY)	PASSIVATE	QQ-P-35
T	6AL-4V TITANIUM	AMS 4911, 4928, 4965, OR 4967	NONE	

OPTIONAL PRIMER

CODE	BASEPLATE PRIMER	SPEC.
P	EPOXY PRIMER	MIL-P-85582
W	FILM PRIMER	CBPS-211

THREAD DATA

CODE	THREAD T
3M	M3 X 0,5 4H5H
4M	M4 X 0,7 4H5H
5M	M5 X 0,8 4H5H

THREAD T

MA3330 OR EQUIVALENT INSERT. INSERT INSTALLED PER MA1567. LUBE PER MIL-L-46010, TYPE 1. THREAD LOCK PER ISO2320. ACCOMODATES ISO5855 MJ THREAD SCREW.

EXAMPLE PART NUMBER

CB5001 CRA 5M 20M H P

OPTIONAL PRIMER COATING ON BASEPLATE
OPTIONAL INSPECTION HOLE
STANDOFF LENGTH L - 20 MM
THREAD SIZE T - M5 X 0,8 4H5H
STANDOFF MATERIAL - A-286 CRES
BASIC PART NUMBER

UNLESS OTHERWISE SPECIFIED, ALL DIMENSIONS ARE IN MILLIMETERS AND TOLERANCES ARE AS SHOWN BELOW. DIMENSIONAL TOLERANCES AND SYMBOLS PER ANSI Y14.5M-1982.

PROPRIETARY PARTS SHOWN IN THIS DRAWING ARE THE SUBJECT OF ISSUED UNITED STATES AND FOREIGN PATENTS AND PATENTS PENDING. UNAUTHORIZED REPRODUCTION AND/OR DISTRIBUTION OF THIS DRAWING IS SPECIFICALLY PROHIBITED.

GLICK BOND

CARSON CITY
NEVADA 89706

CAD CB5001-2
METRIC DIMENSIONS

ANGLES	±1°
.X	±0,8
.XX	±0,25

APPROVALS	DATE
DRAWN BSP	5FEB01
CHECKED DAC	5FEB01
RELEASED CGH	6FEB01
REVISED BSP	5FEB01

TITLE			
STANDOFF, LOCKING THREAD, SMALL BASE			
SIZE	CAGE CODE	DWG. NO.	REV.
A	66530	CB5001 (METRIC)	15
SCALE	1/1 5FEB01		SHEET 2 OF 2