

NUTPLATE ATTACHED BY ADHESIVE APPLIED TO THIS SURFACE.

DISPOSABLE ELASTIC FIXTURE HOLDS NUTPLATE WHILE ADHESIVE CURES.

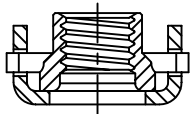

NUTPLATE MEETS THE STRENGTH REQUIREMENTS OF NASM25027.

THREAD AND DIMENSION DATA (ALL DIMENSIONS BEFORE PAINT)

PART NUMBER	THREAD T	A MAX	B MAX	D MIN	E MAX	H MAX	R MIN	WEIGHT * (A-286 CRES) LB/100	WEIGHT * (ALUMINUM) LB/100
CB6011 ( ) 08 ( ) 1	.1640-32 UNJC-3B	.745	.454	.224	.285	.250	.070	.60	.37
CB6011 ( ) 3 ( ) 1	.1900-32 UNJF-3B	.745	.454	.250	.285	.250	.070	.63	.40
CB6011 ( ) 3 ( ) 2						.312	.125	.68	.45
CB6011 ( ) 3 ( ) 3						.375	.188	.73	.50
CB6011 ( ) 3 ( ) 4						.438	.250	.80	.57
CB6011 ( ) 3 ( ) 5						.500	.313	.84	.61
CB6011 ( ) 3 ( ) 6						.562	.375	.89	.66
CB6011 ( ) 4 ( ) 1	.2500-28 UNJF-3B	.948	.554	.312	.360	.295	.070	1.14	.72
CB6011 ( ) 4 ( ) 2						.357	.125	1.19	.77
CB6011 ( ) 4 ( ) 3						.419	.188	1.23	.81
CB6011 ( ) 4 ( ) 4						.481	.250	1.32	.90
CB6011 ( ) 4 ( ) 5						.543	.313	1.41	.99
CB6011 ( ) 4 ( ) 6						.605	.375	1.51	1.09
CB6011 ( ) 5 ( ) 1	.3125-24 UNJF-3B	1.042	.650	.375	.410	.344	.070	1.60	1.06
CB6011 ( ) 5 ( ) 2						.400	.125	1.66	1.12
CB6011 ( ) 5 ( ) 3						.461	.188	1.77	1.23
CB6011 ( ) 5 ( ) 4						.524	.250	1.89	1.35
CB6011 ( ) 5 ( ) 5						.586	.313	2.00	1.46
CB6011 ( ) 5 ( ) 6						.649	.375	2.11	1.57
CB6011 ( ) 6 ( ) 1	.3750-24 UNJF-3B	1.182	.750	.437	.460	.380	.070	2.62	1.65
CB6011 ( ) 6 ( ) 2						.430	.125	2.74	1.77
CB6011 ( ) 7 ( ) 1	.4375-20 UNJF-3B	1.307	.840	.500	.510	.500	.070	4.00	2.90
CB6011 ( ) 8 ( ) 1	.5000-20 UNJF-3B	1.432	.900	.562	.573	.580	.070	4.65	3.30

\* APPROXIMATE WEIGHT WITHOUT INSTALLATION FIXTURE (BASEPLATE MATERIAL IN PARENTHESIS).

UNLESS OTHERWISE SPECIFIED, ALL DIMENSIONS ARE IN INCHES AND TOLERANCES ARE AS SHOWN BELOW. DIMENSIONAL TOLERANCES AND SYMBOLS PER ANSI Y14.5M-1982.

PROPRIETARY PARTS SHOWN IN THIS DRAWING ARE THE SUBJECT OF ISSUED UNITED STATES AND FOREIGN PATENTS AND PATENTS PENDING. UNAUTHORIZED REPRODUCTION AND/OR DISTRIBUTION OF THIS DRAWING IS SPECIFICALLY PROHIBITED.

**GLICK BOND**

CARSON CITY  
NEVADA 89706

CAD CB6011-1

APPROVALS

DATE

TITLE

ANGLES ±1°

DRAWN *DAC* 17OCT03

NUTPLATE, ONE LUG, ADHESIVE BONDED

.XX ±.03

CHECKED *DAC* 17OCT03

SIZE A CAGE CODE 66530 DWG. NO. CB6011 REV. 14

.XXX ±.010

RELEASED *DAC* 17OCT03

SCALE 2/1 17OCT03 SHEET 1 OF 4

.XXXX ±.001

REVISED *DAC* 17OCT03

INSTALLATION HOLE SIZE AND REPLACEMENT COMPONENTS

THREAD CODE	U MAX	NUT PART NO. *	CLIP PART NO.
08	.224	CB6001 ( ) 08-1	CB6002-3
3	.250	CB6001 ( ) 3-( )	CB6002-3
4	.312	CB6001 ( ) 4-( )	CB6002-4
5	.375	CB6001 ( ) 5-( )	CB6002-5
6	.437	CB6001 ( ) 6-( )	CB6002-6
7	.500	CB6001 ( ) 7-1	CB6002-7
8	.562	CB6001 ( ) 8-1	CB6002-8

OVERSIZE HOLE

THREAD CODE	U OVERSIZE
08	.224-.286
3	.250-.312
4	.312-.375
5	.375-.437
6	.437-.500
7	.500-.562
8	.562-.625

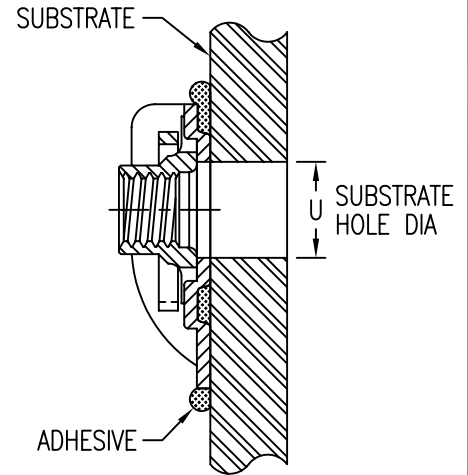

\* FIRST ( ) DESIGNATES NUT MATERIAL CODE.

- CR = A-286 CRES, PASSIVATE, DRI-FILM LUBE.
- CRC = A-286 CRES, CAD PLATE, DRI-FILM LUBE.
- CRS = A-286 CRES, SILVER PLATE.

FOR OVERSIZE HOLE USE "BF" SUFFIX.

SECOND ( ) DESIGNATES NUTPLATE THREAD RELIEF (NUT C'BORE) CODE.

"NL" SUFFIX TO NUT PART NO. INDICATES NON-LOCKING NUT ELEMENT.

BASEPLATE MATERIAL AND FINISH DATA

CODE	MATERIAL	SPEC.	FINISH	SPEC.
A	ALUMINUM	QQ-A-250	NONE	
AA	ALUMINUM	QQ-A-250	ANODIZE	MIL-A-8625, TY 1
CR	A-286 CRES	AMS 5525	PASSIVATE	QQ-P-35

RETAINING CLIP: (SEE CB6002)

MATERIAL: 302 CRES PER AMS 5688 OR 5866, OR ARMCO 18-2 MN CRES.

FINISH: PASSIVATE PER QQ-P-35.

OPTIONAL PRIMER COATING ON BASEPLATE: EPOXY PRIMER PER MIL-P-85582.

NUT MATERIAL AND FINISH DATA (SEE CB6001)

CODE	MATERIAL	FINISH	SPEC.	LUBRICATION	SPEC.
-	A-286 CRES	PASSIVATE	QQ-P-35	DRI-FILM LUBE	MIL-L-46010, TY 1
CRC	A-286 CRES	CADMIUM PLATING	QQ-P-416	DRI-FILM LUBE	MIL-L-46010, TY 1
CRS	A-286 CRES	SILVER PLATING	AMS 2410	NONE	

NOTES: (PART NUMBER CHANGE 18NOV96, NUTPLATE DESIGN SAME)

1. CB6011( )2( )1 PART NUMBER IS INACTIVE FOR NEW DESIGN. USE CB6011( )08( )1.
2. NUT MATERIAL AND FINISH DESIGNATION (CR) IS INACTIVE FOR NEW DESIGN. NUT MATERIAL AND FINISH CODE (-) HAS REPLACED (CR).

PROCUREMENT SPECIFICATION: NASM25027

PART NUMBER SUFFIXES

SUFFIX	DESCRIPTION
NL	NON-LOCKING NUT ELEMENT
BF	FIXTURE FOR OVERSIZE INSTALLATION HOLE

EXAMPLE PART NUMBER

CB6011 CR 3 - 1 P

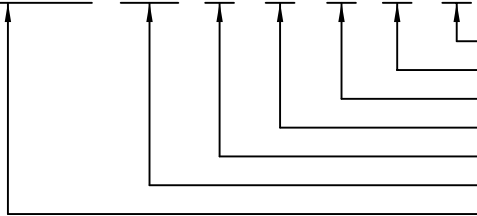

PART NUMBER SUFFIX  
 OPTIONAL PRIMER COATING ON BASEPLATE  
 THREAD RELIEF R - .070 MIN  
 NUT MATERIAL - A-286 CRES, DRI-FILM LUBE  
 THREAD T SIZE - .1900-32 UNJF-3B  
 BASEPLATE MATERIAL - A-286 CRES  
 BASIC PART NUMBER

UNLESS OTHERWISE SPECIFIED, ALL DIMENSIONS ARE IN INCHES AND TOLERANCES ARE AS SHOWN BELOW. DIMENSIONAL TOLERANCES AND SYMBOLS PER ANSI Y14.5M-1982.

PROPRIETARY PARTS SHOWN IN THIS DRAWING ARE THE SUBJECT OF ISSUED UNITED STATES AND FOREIGN PATENTS AND PATENTS PENDING. UNAUTHORIZED REPRODUCTION AND/OR DISTRIBUTION OF THIS DRAWING IS SPECIFICALLY PROHIBITED.

**GLICK BOND**

CARSON CITY  
NEVADA 89706

CAD CB6011-2		APPROVALS		DATE	TITLE			
ANGLES	±1°	DRAWN	DAC	17OCT03	NUTPLATE, ONE LUG, ADHESIVE BONDED			
.XX	±.03	CHECKED	DAC/John	17OCT03	SIZE	CAGE CODE	DWG. NO.	REV.
.XXX	±.010	RELEASED	DAC/John	17OCT03	A	66530	CB6011	14
.XXXX	±.001	REVISED	DAC	17OCT03	SCALE	2/1 17OCT03		SHEET 2 OF 4

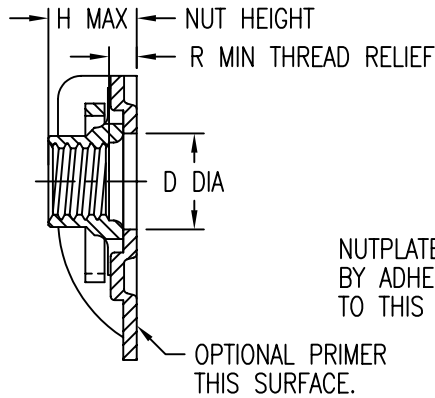
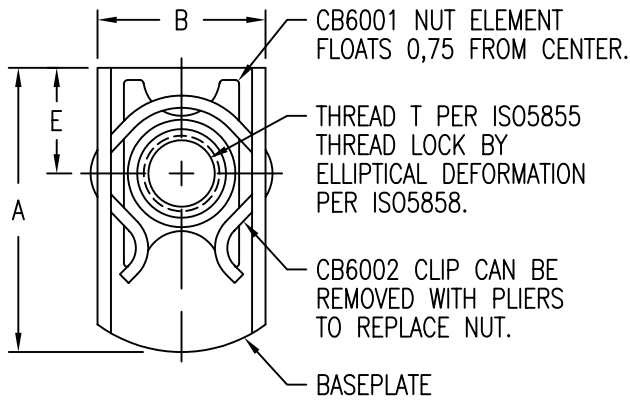

NUTPLATE ATTACHED BY ADHESIVE APPLIED TO THIS SURFACE.

DISPOSABLE ELASTIC FIXTURE HOLDS NUTPLATE WHILE ADHESIVE CURES.

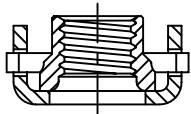

NUTPLATE MEETS THE STRENGTH REQUIREMENTS OF ISO5858 (900 MPa).

THREAD AND DIMENSION DATA (ALL DIMENSIONS BEFORE PAINT)

PART NUMBER	THREAD T	A MAX	B MAX	D MIN	E MAX	H MAX	R MIN	WEIGHT * (A-286 CRES) GRAMS	WEIGHT * (ALUMINUM) GRAMS
CB6011 ( ) 4M ( ) 1	MJ4 X 0,7 4H6H	19,0	11,6	5,50	7,3	5,2	1,6	2,8	1,7
CB6011 ( ) 5M ( ) 1	MJ5 X 0,8 4H6H	19,0	11,6	6,35	7,3	6,2	1,6	2,9	1,8
CB6011 ( ) 5M ( ) 4						8,0	4,0	3,3	2,1
CB6011 ( ) 5M ( ) 6						10,0	6,0	3,6	2,4
CB6011 ( ) 5M ( ) 8						12,0	8,0	3,9	2,7
CB6011 ( ) 5M ( ) 10						14,0	10,0	4,2	3,0
CB6011 ( ) 5M ( ) 12						16,0	12,0	4,5	3,3
CB6011 ( ) 6M ( ) 1	MJ6 X 1,0 4H5H	24,1	14,1	7,50	9,2	7,1	1,6	5,0	3,2
CB6011 ( ) 6M ( ) 4						9,0	4,0	5,5	3,7
CB6011 ( ) 6M ( ) 6						11,0	6,0	6,0	4,2
CB6011 ( ) 6M ( ) 8						13,0	8,0	6,5	4,7
CB6011 ( ) 6M ( ) 10						15,0	10,0	7,0	5,2
CB6011 ( ) 6M ( ) 12						17,0	12,0	7,5	5,7
CB6011 ( ) 8M ( ) 1	MJ8 X 1,0 4H5H	26,5	16,6	9,50	10,5	8,2	1,6	7,3	4,7
CB6011 ( ) 8M ( ) 4						11,0	4,0	7,9	5,3
CB6011 ( ) 8M ( ) 6						13,0	6,0	8,6	6,0
CB6011 ( ) 8M ( ) 8						15,0	8,0	9,2	6,6
CB6011 ( ) 8M ( ) 10						17,0	10,0	9,8	7,2
CB6011 ( ) 8M ( ) 12						19,0	12,0	10,5	7,9
CB6011 ( ) 10M ( ) 1	MJ10 X 1,25 4H5H	30,1	19,1	11,10	11,7	9,9	1,6	12,7	8,3

\* APPROXIMATE WEIGHT WITHOUT INSTALLATION FIXTURE (BASEPLATE MATERIAL IN PARENTHESIS).

UNLESS OTHERWISE SPECIFIED, ALL DIMENSIONS ARE IN MILLIMETERS AND TOLERANCES ARE AS SHOWN BELOW. DIMENSIONAL TOLERANCES AND SYMBOLS PER ANSI Y14.5M-1982.

PROPRIETARY PARTS SHOWN IN THIS DRAWING ARE THE SUBJECT OF ISSUED UNITED STATES AND FOREIGN PATENTS AND PATENTS PENDING. UNAUTHORIZED REPRODUCTION AND/OR DISTRIBUTION OF THIS DRAWING IS SPECIFICALLY PROHIBITED.



CARSON CITY NEVADA 89706

CAD CB6011-3  
METRIC DIMENSIONS

ANGLES	±1°
.X	±0,8
.XX	±0,25

APPROVALS	DATE
DRAWN <i>DAC</i>	17OCT03
CHECKED <i>DAC/John</i>	17OCT03
RELEASED <i>ABC/John</i>	17OCT03
REVISED <i>DAC</i>	17OCT03

TITLE NUTPLATE, ONE LUG, ADHESIVE BONDED			
SIZE A	CAGE CODE 66530	DWG. NO. CB6011 (METRIC)	REV. 14
SCALE 2/1	17OCT03		SHEET 3 OF 4

INSTALLATION HOLE SIZE AND REPLACEMENT COMPONENTS

THREAD CODE	U MAX	NUT PART NO. *	CLIP PART NO.
4M	5,50	CB6001 ( ) 4M 1	CB6002-5M
5M	6,35	CB6001 ( ) 5M ( )	CB6002-5M
6M	7,50	CB6001 ( ) 6M ( )	CB6002-6M
8M	9,50	CB6001 ( ) 8M ( )	CB6002-8M
10M	11,10	CB6001 ( ) 10M 1	CB6002-10M

\* FIRST ( ) DESIGNATES NUT MATERIAL CODE.

- CR = A-286 CRES, PASSIVATE, DRI-FILM LUBE.
- CRC = A-286 CRES, CAD PLATE, DRI-FILM LUBE.
- CRS = A-286 CRES, SILVER PLATE.

SECOND ( ) DESIGNATES NUTPLATE THREAD RELIEF (NUT C'BORE) CODE.

"NL" SUFFIX TO NUT PART NO. INDICATES NON-LOCKING NUT ELEMENT.

OVERSIZE HOLE

THREAD CODE	U OVERSIZE
4M	5,50-7,00
5M	6,35-7,85
6M	7,50-9,00
8M	9,50-11,00
10M	11,10-12,60

FOR OVERSIZE HOLE USE "BF" SUFFIX.

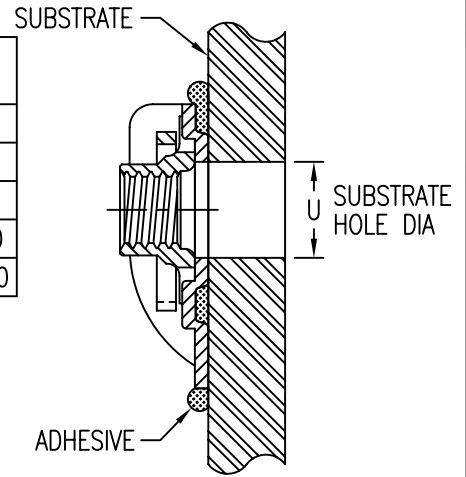

BASEPLATE MATERIAL AND FINISH DATA

CODE	MATERIAL	SPEC.	FINISH	SPEC.
A	ALUMINUM	QQ-A-250	NONE	
AA	ALUMINUM	QQ-A-250	ANODIZE	MIL-A-8625, TY 1
CR	A-286 CRES	AMS 5525	PASSIVATE	QQ-P-35

RETAINING CLIP: (SEE CB6002)

MATERIAL: 302 CRES PER AMS 5688 OR 5866, OR ARMC0 18-2 MN CRES.

FINISH: PASSIVATE PER QQ-P-35.

OPTIONAL PRIMER COATING ON BASEPLATE: EPOXY PRIMER PER MIL-P-85582.

NUT MATERIAL AND FINISH DATA (SEE CB6001)

CODE	MATERIAL	FINISH	SPEC.	LUBRICATION	SPEC.
NONE	A-286 CRES	PASSIVATE	QQ-P-35	DRI-FILM LUBE	MIL-L-46010, TY 1
CRC	A-286 CRES	CADMIUM PLATING	QQ-P-416	DRI-FILM LUBE	MIL-L-46010, TY 1
CRS	A-286 CRES	SILVER PLATING	AMS 2410	NONE	

PART NUMBER SUFFIXES

SUFFIX	DESCRIPTION
NL	NON-LOCKING NUT ELEMENT
BF	FIXTURE FOR OVERSIZE INSTALLATION HOLE

EXAMPLE PART NUMBER

CB6011 CR 5M 1 P

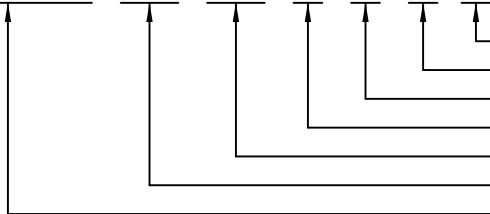

- PART NUMBER SUFFIX
- OPTIONAL PRIMER COATING ON BASEPLATE
- THREAD RELIEF R - 1,6 MIN
- NUT MATERIAL - A-286 CRES, DRI-FILM LUBE
- THREAD T SIZE - MJ5 X 0,8 4H6H
- BASEPLATE MATERIAL - A-286 CRES
- BASIC PART NUMBER

UNLESS OTHERWISE SPECIFIED, ALL DIMENSIONS ARE IN MILLIMETERS AND TOLERANCES ARE AS SHOWN BELOW. DIMENSIONAL TOLERANCES AND SYMBOLS PER ANSI Y14.5M-1982.

PROPRIETARY PARTS SHOWN IN THIS DRAWING ARE THE SUBJECT OF ISSUED UNITED STATES AND FOREIGN PATENTS AND PATENTS PENDING. UNAUTHORIZED REPRODUCTION AND/OR DISTRIBUTION OF THIS DRAWING IS SPECIFICALLY PROHIBITED.

**GLICK BOND**

CARSON CITY  
NEVADA 89706

CAD CB6011-4  
METRIC DIMENSIONS

APPROVALS	DATE
DRAWN <i>DAC</i>	17OCT03
CHECKED <i>DAC/John</i>	17OCT03
RELEASED <i>DAC/John</i>	17OCT03
REVISED <i>DAC</i>	17OCT03

TITLE  
NUTPLATE, ONE LUG, ADHESIVE BONDED

ANGLES	±1°
.X	±0,8
.XX	±0,25

SIZE	CAGE CODE	DWG. NO.	REV.
A	66530	CB6011 (METRIC)	14
SCALE	2/1	17OCT03	SHEET 4 OF 4