

THREAD AND DIMENSION DATA (ALL DIMENSIONS BEFORE PAINT)

PART NUMBER	THREAD T	A MAX	B MAX	D MIN	E MAX	H MAX	R MIN	U DIA	WEIGHT * LB/100	AXIAL TENSILE STRENGTH LBS MIN
CN611CR08	.164-32 UNC-2B	.745	.454	.224	.285	.250	.070	.164-.224	.60	1720
CN611CR3	.190-32 UNF-2B	.745	.454	.250	.285	.250	.070	.190-.250	.63	2460
CN611CR324	.190-24 UNC-2B	.745	.454	.250	.285	.250	.070	.190-.250	.63	2010
CN611CR4	.250-28 UNF-2B	.948	.554	.312	.360	.295	.070	.250-.312	1.14	4580
CN611CR420	.250-20 UNC-2B	.948	.554	.312	.360	.295	.070	.250-.312	1.14	3760
CN611CR5	.312-24 UNF-2B	1.042	.650	.375	.410	.344	.070	.313-.375	1.60	7390
CN611CR518	.312-18 UNC-2B	1.042	.650	.375	.410	.344	.070	.313-.375	1.60	6360

* REFERENCE WEIGHT WITHOUT INSTALLATION FIXTURE.

BASEPLATE MATERIAL AND FINISH DATA

CODE	MATERIAL	FINISH
CR	A-286 CRES	PASSIVATE

OPTIONAL BASEPLATE PRIMER

CODE	BASEPLATE PRIMER
P	EPOXY PRIMER

NUT MATERIAL AND FINISH DATA

CODE	MATERIAL	FINISH	LUBRICATION
CR	A-286 CRES	PASSIVATE	DRI-FILM LUBE

CLIP MATERIAL AND FINISH DATA

CODE	MATERIAL	FINISH
CR	302 CRES OR 18-2 MN CRES	PASSIVATE

EXAMPLE PART NUMBER

CN611 CR 3 P

OPTIONAL PRIMER COATING ON BASEPLATE
 THREAD T SIZE - .190-32 UNF-2B
 NUT AND BASEPLATE MATERIAL - A-286 CRES
 BASIC PART NUMBER

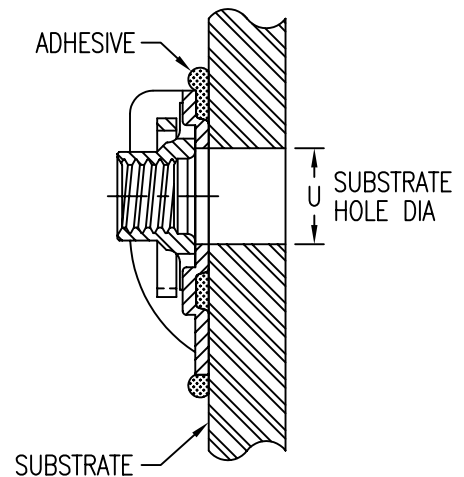

UNLESS OTHERWISE SPECIFIED, ALL DIMENSIONS ARE IN INCHES AND TOLERANCES ARE AS SHOWN BELOW. DIMENSIONAL TOLERANCES AND SYMBOLS PER ANSI Y14.5M-1982.

PROPRIETARY PARTS SHOWN IN THIS DRAWING ARE THE SUBJECT OF ISSUED UNITED STATES AND FOREIGN PATENTS AND PATENTS PENDING. UNAUTHORIZED REPRODUCTION AND/OR DISTRIBUTION OF THIS DRAWING IS SPECIFICALLY PROHIBITED.

CLICK BOND

CARSON CITY
NEVADA 89706

APPROVALS		DATE	TITLE				
ANGLES	±1°	DRAWN <i>DAC</i>	16MAY03	NUTPLATE, ONE LUG, ADHESIVE BONDED			
.XX	±.03	CHECKED <i>DAC/mtm</i>	16MAY03	SIZE	CAGE CODE	DWG. NO.	REV.
.XXX	±.010	RELEASED <i>DAC/mtm</i>	16MAY03	A	66530	CN611	1
.XXXX	±.001	REVISED <i>DAC</i>	16MAY03	SCALE	2/1	16MAY03	SHEET 1 OF 1