



VNM SIMULATION .,JSC



VNM SIMULATION .,JSC VNM MOTION SYSTEM INSTALLION GUIDE



VNM SIMULATION .,JSC

MỤC LỤC/Table Of Content



VNM SIMULATION .,JSC

1. Vertical Actuator

Danh sách linh kiện VNM Actuator trực dọc/ VNM Vertical Actuator Part list				
STT	Tên/Part Name	Mô tả/description	Ghi chú/note	Số lượng/QTY
1	VNM Actuator	VNM Actuator		1
2	Gá Actuator trực dọc U-Bracket	310*140*85mm		1
3	Chân Actuator chịu lực có bi cầu Actuator foot	Ø80mm, M16		1
4	Đai ốc/ Hexagon nut m16	M16		1
5	Đệm vênh / Spring washer m16	M16		1
6	Inox LGC đầu Mo LGC Bolt M8*16	M8*16		12
7	Đệm vênh / Spring washer m8	M8		12
8	Đệm phẳng / Flat washer m8	M8		12



VNM SIMULATION .,JSC

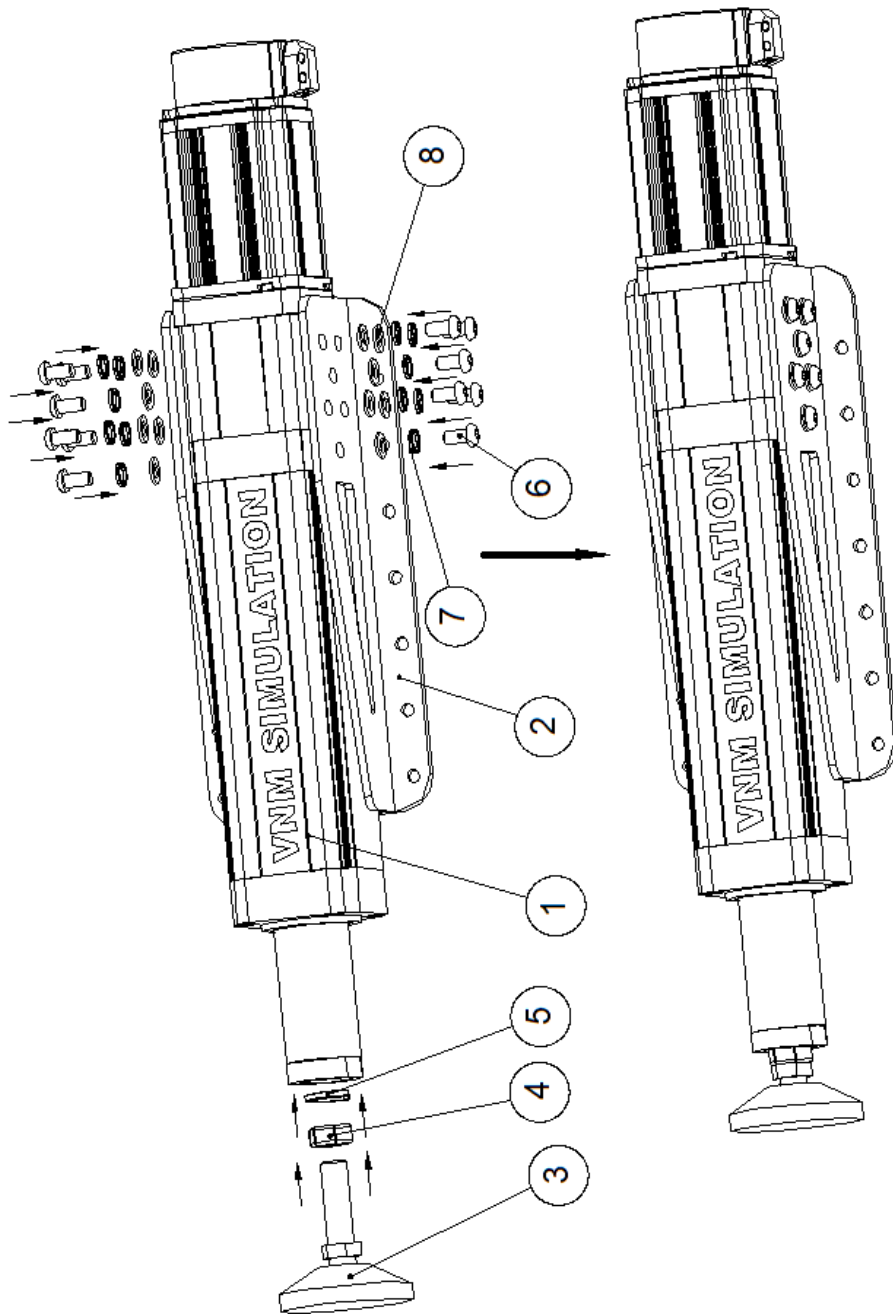



VNM SIMULATION .,JSC

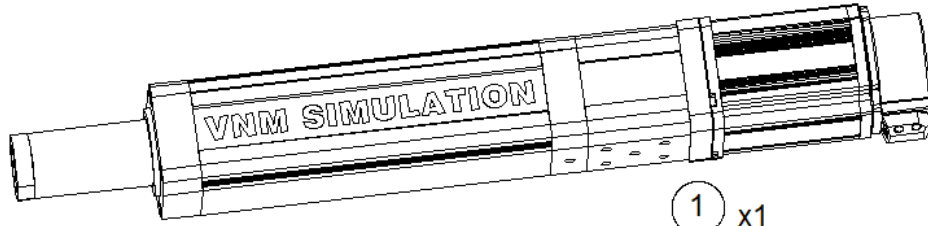

1 x1

VNM Actuator

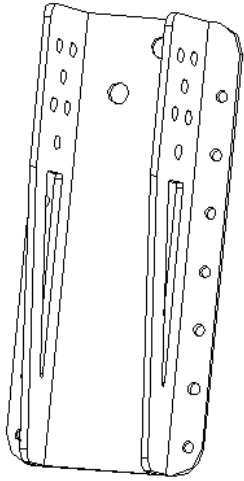

2 x1

Gá Actuator trục dọc
U Bracket

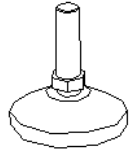

3 x1

Chân Actuator chịu lực có bi cầu
Heavy support feet with ball steel



4 x1

Ecu M16
Check nut M16



5 x1

Đệm vênh M16
Spring washer M16



6 x12

Inox LGC đầu mo M8x16
Hexagon socket button head M8x16



7 x12

Đệm vênh M8
Spring washer M8



8 x12

Đệm phẳng M8
Flat washer M8



VNM SIMULATION .,JSC

2. Rig V1

Danh sách linh kiện của bộ VNM Rig V1/VNM RIG V1 Part list				
STT /NO	Tên/Part name	Mô tả/Description	Ghi chú/Note	Số lượng/QTY
1	Nhôm định hình 40*80 ALU extrusion 40*80	1200mm		2
2	Nhôm định hình 40*80 ALU extrusion 40*80	720mm		2
3	Nhôm định hình 40*80 ALU extrusion 40*80	500mm		6
4	Nhôm định hình 40*40 ALU extrusion 40*80	350mm		1
5	Ke góc 4040 Conner bucket 4040	40*40*38mm		11
6	Ke góc 4080 Conner bucket 4040	40*80*78mm		14
7	Bộ gá Shifter-Handbrake Shifter-handbrake mount	210*180*80mm		1
8	Bộ gá Direct Drive Direct Drive Mount	580*170*158mm		1
9	Bộ gá Pedal Pedal Mount	500*336*120mm		1
10	Tấm nối nhôm T cho gá Shifter-Handbrake T-bracket for Shifter/handbrake mount	160*160*5mm		1



VNM SIMULATION .,JSC

① x 2
40x80x1200

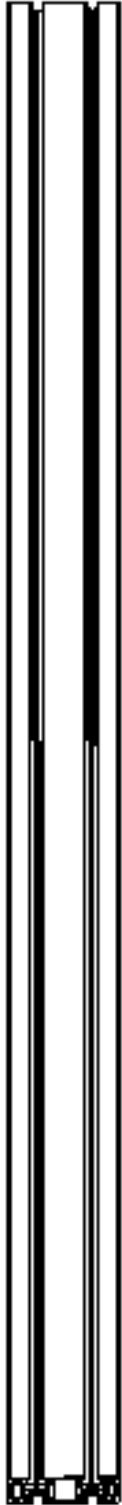

② x 2
40x80x720



③ x 6
40x80x500



④ x 1
40x40x350





VNM SIMULATION .,JSC

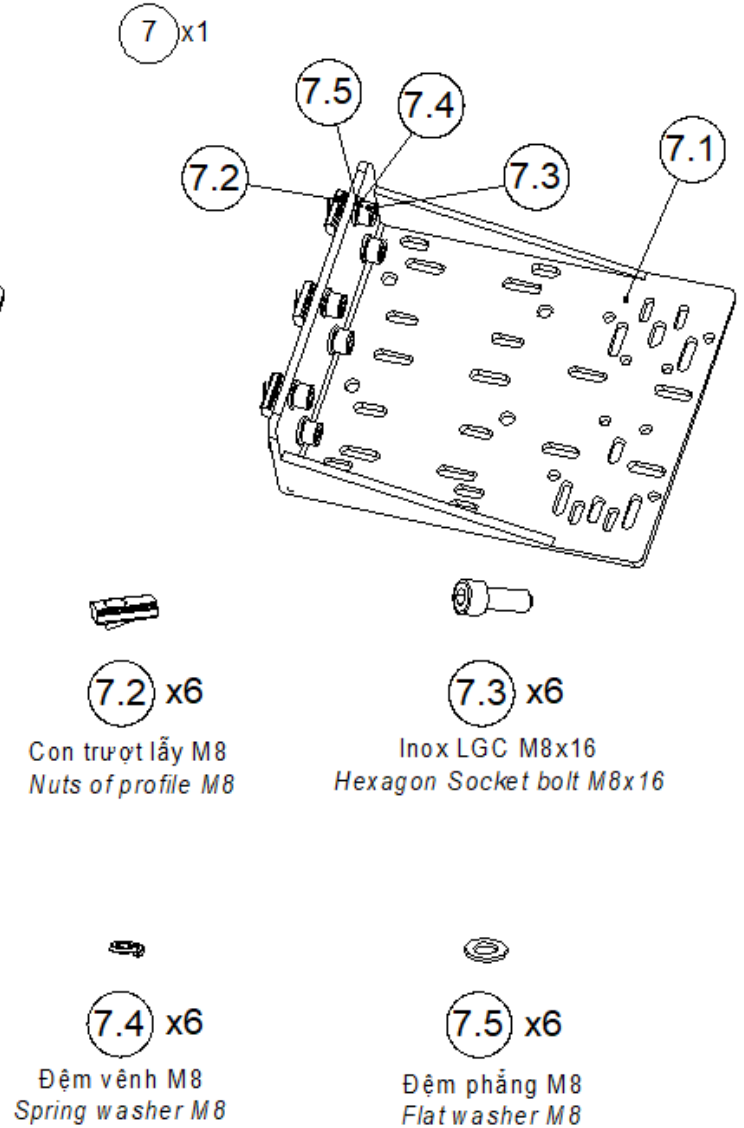
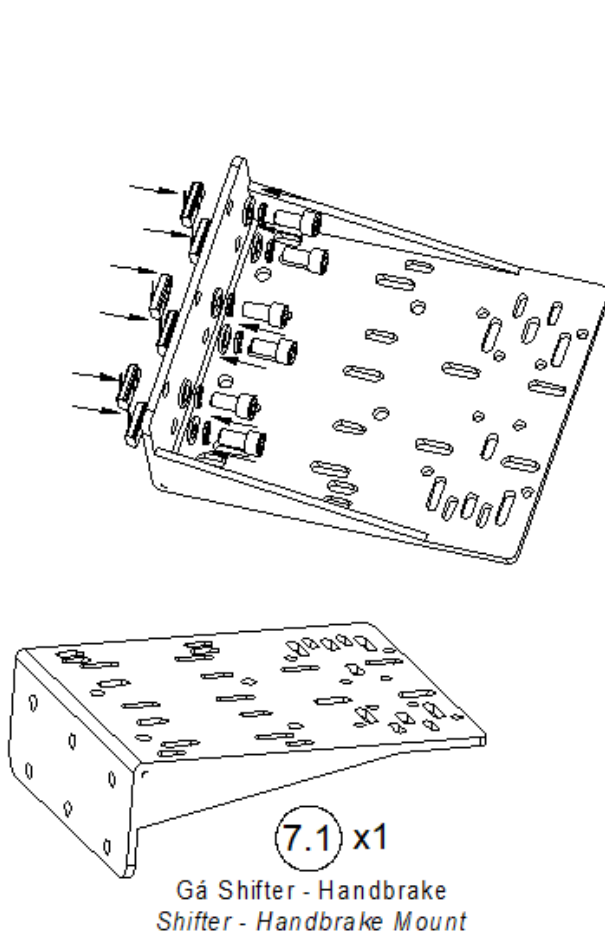
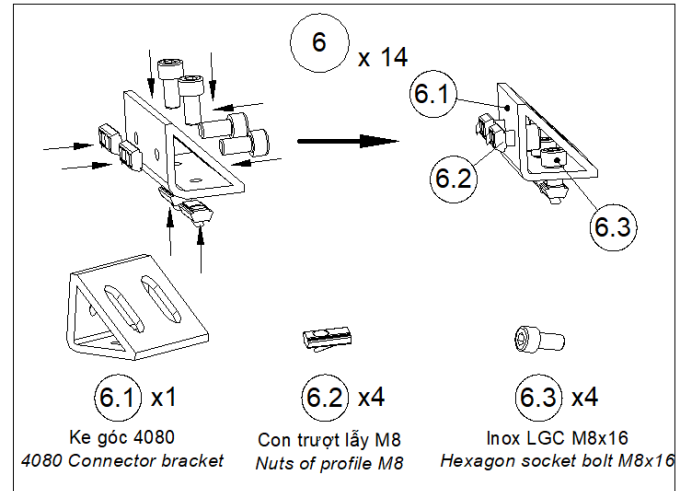
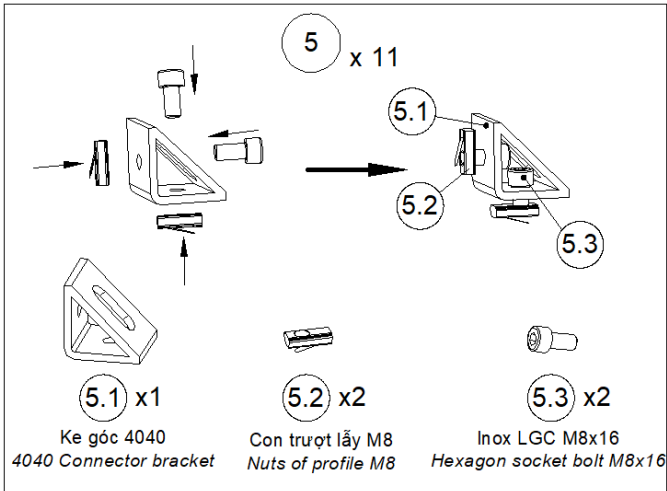



VNM SIMULATION .,JSC

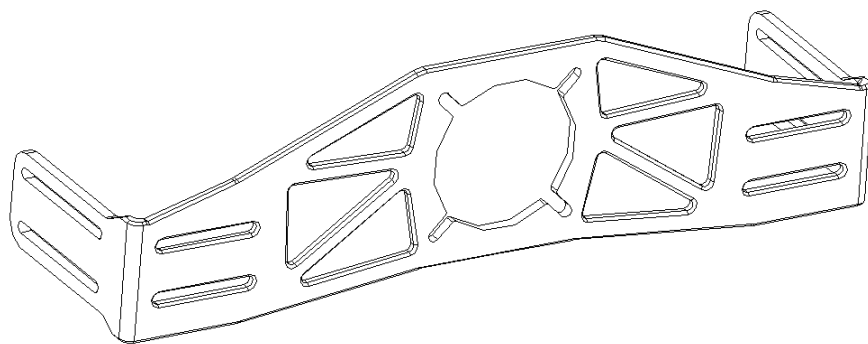
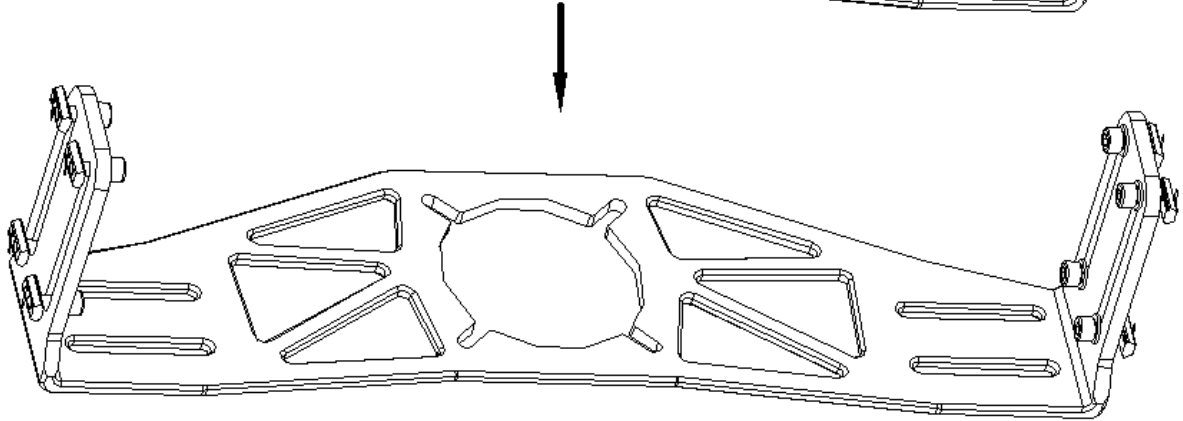
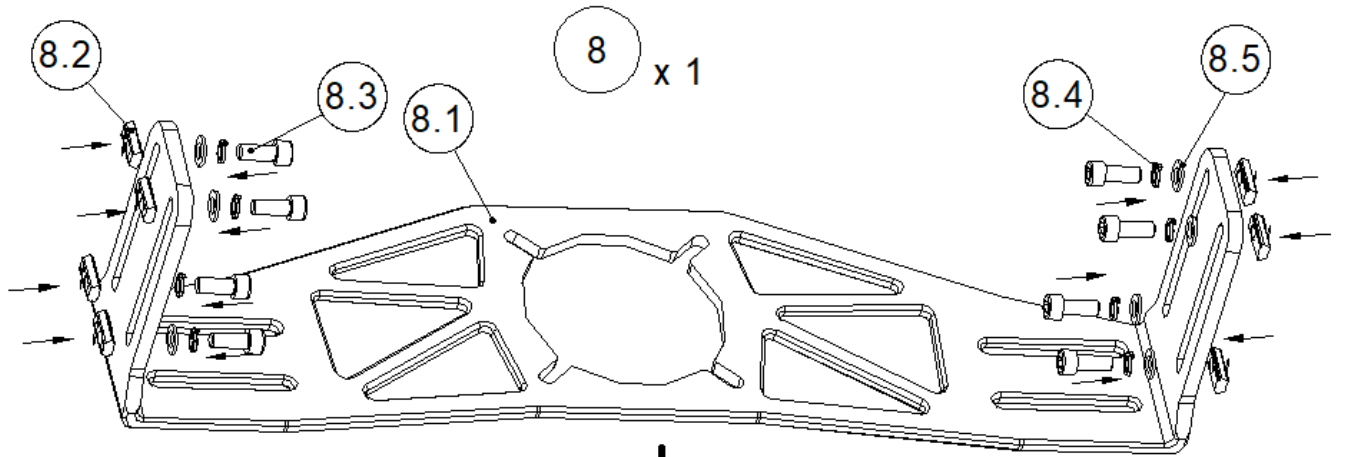

8.2 x8

Con trượt lấy M8
Nuts of profile M8



8.3 x8

Inox LGC M8x20
Hexagon Socket bolt M8x20



8.4 x8

Đệm vênh M8
Spring washer M8



8.5 x8

Đệm phẳng M8
Flat washer M8

8.1 x1

Gá Direct Drive
Direct Drive Mount



VNM SIMULATION ,JSC

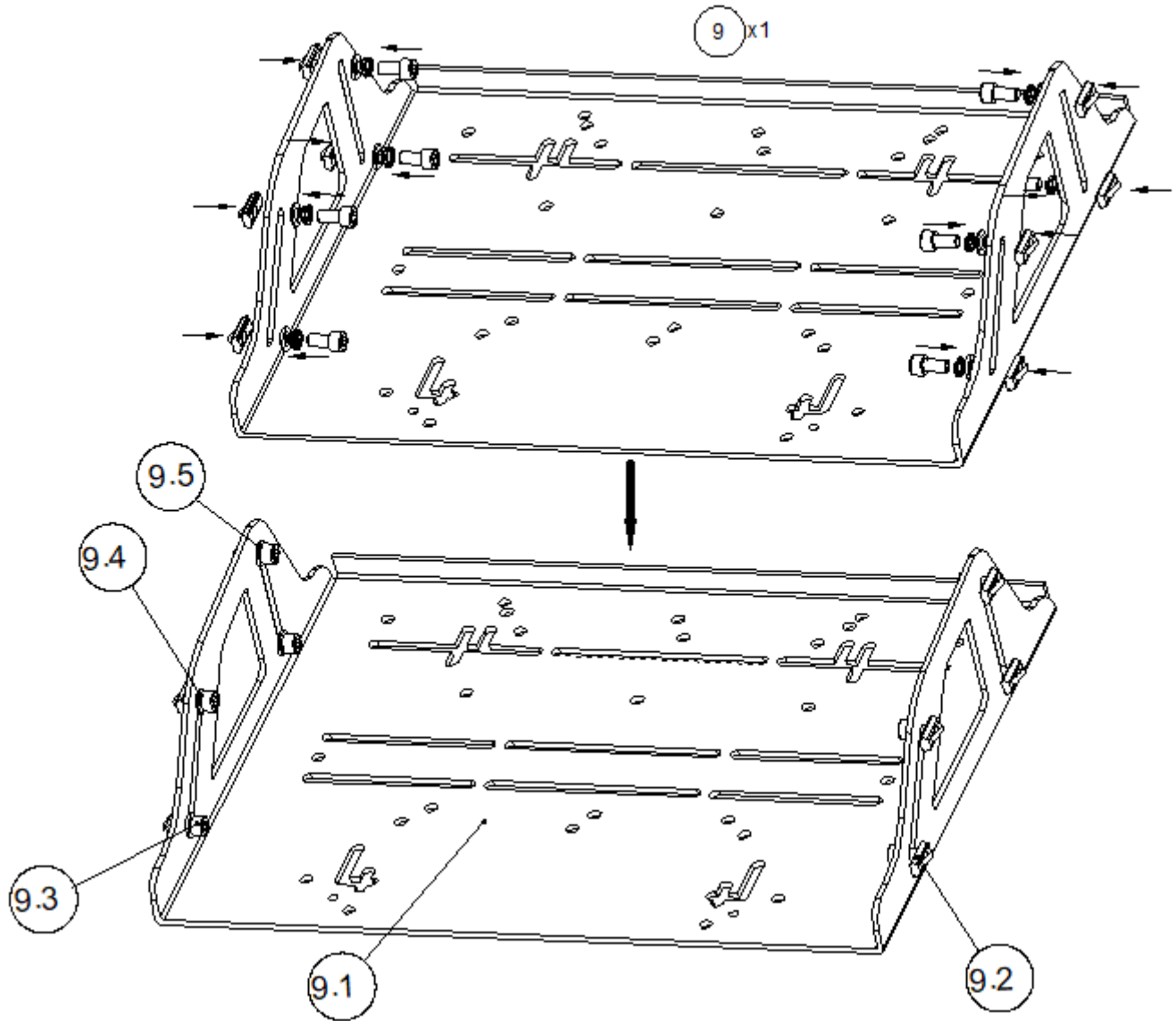



VNM SIMULATION .,JSC

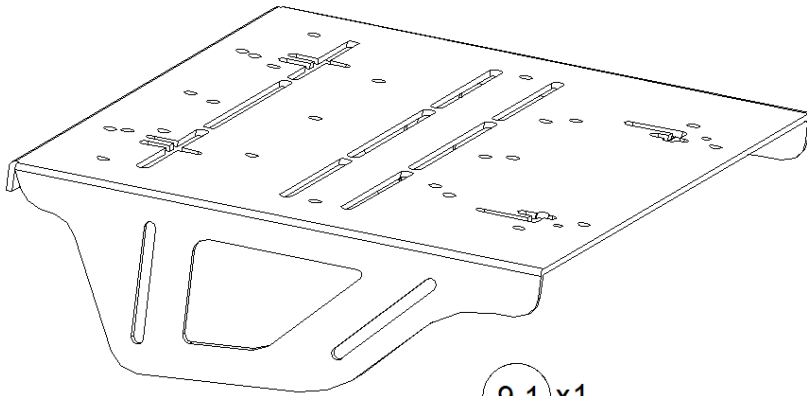

9.1 x1
Gá Pedal
Pedal mount



9.2 x8

Con trượt lấy M8
Nuts of profile M8



9.3 x8

Inox LGC M8x16
Hexagon Socket bolt M8x16



9.4 x8

Đệm vênh M8
Spring washer M8



9.5 x8

Đệm phẳng M8
Flat washer M8

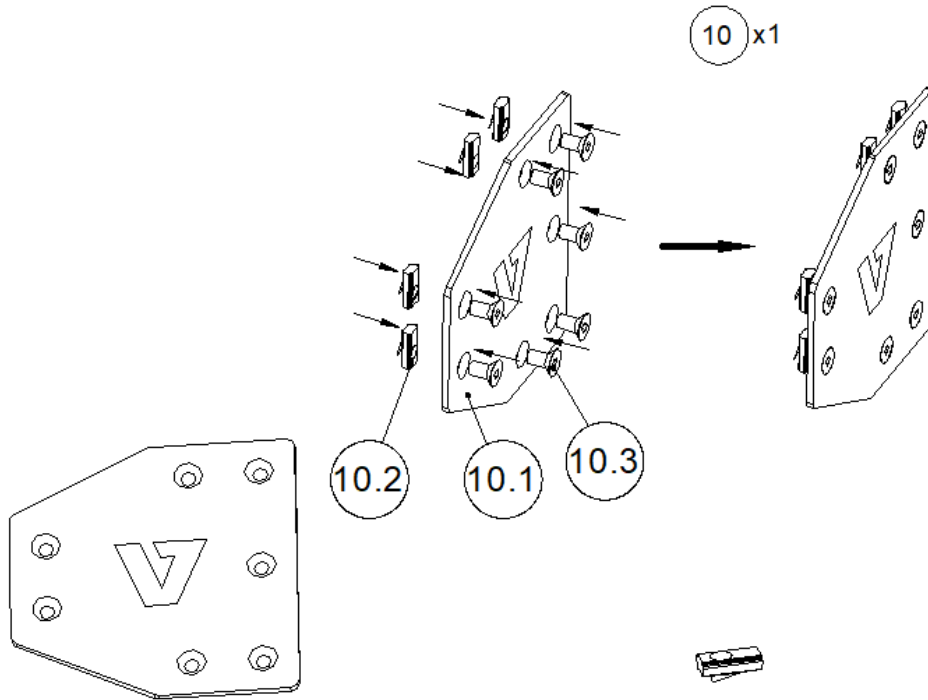

10 x1

10.2

10.1

10.3

10.1 x1

Tấm nối nhôm gá Shifter-Handbrake
Plate connect aluminum Shifter-Handbrake



10.2 x7

Con trượt lấy M8
Nuts of profile M8



10.3 x7

Inox LGC đầu bằng M8x16
Hexagon Socket countersunk flat bolt M8x16



VNM SIMULATION .,JSC



VNM SIMULATION .,JSC

3. Motion 3 DOF 4 Actuator

VNM Motion 3 DOF 4 Actuator				
STT /NO	Tên/Part name	Mô tả/Description	Ghi chú/Note	Số lượng/QTY
1	Khung buồng lái VNM V1 / VNM Rig V1			1
2	Bộ Actuator trục dọc Vertical Actuator set		VNM actuator + U bucket + actuator foot	4

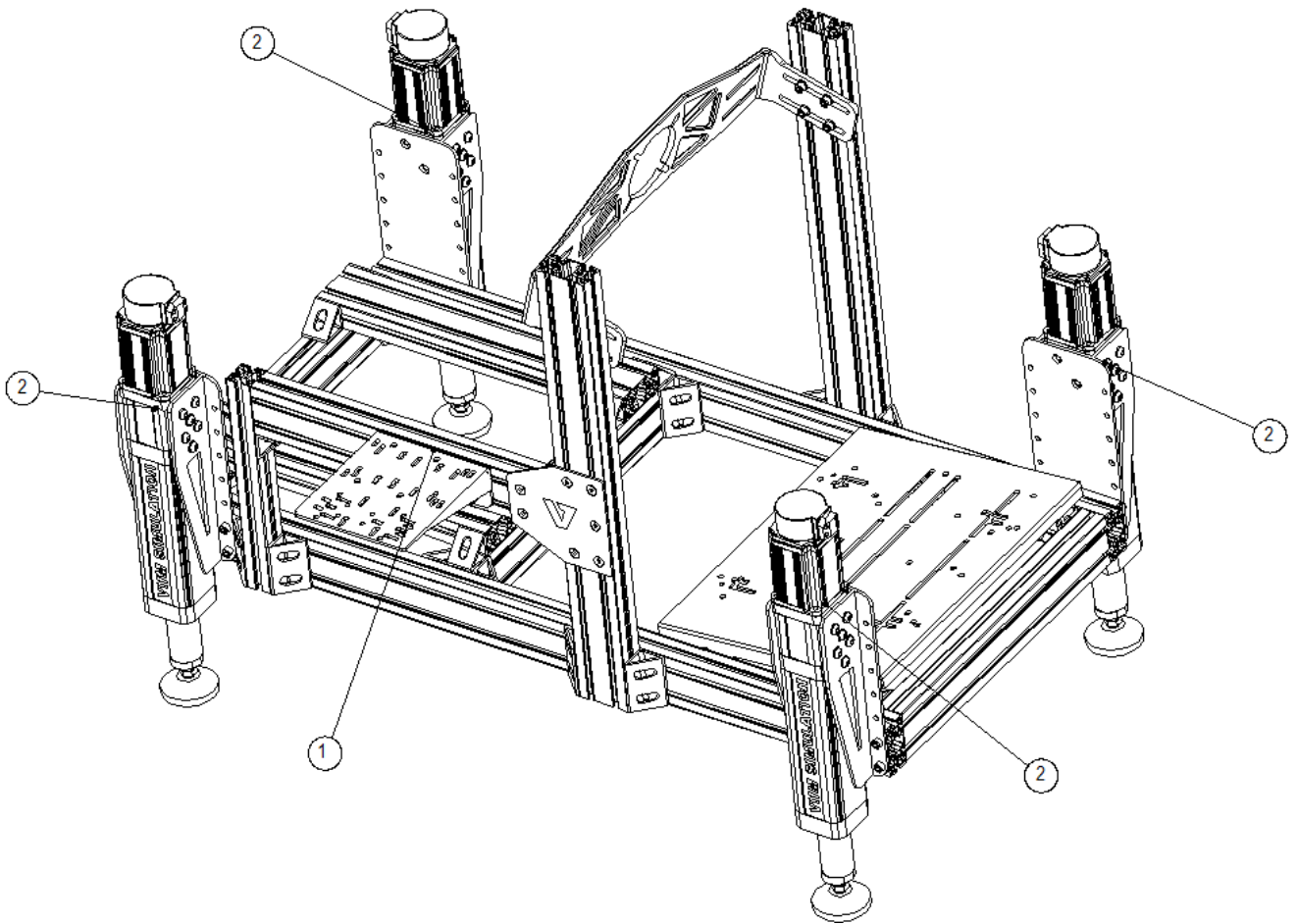



VNM SIMULATION .,JSC

① x1

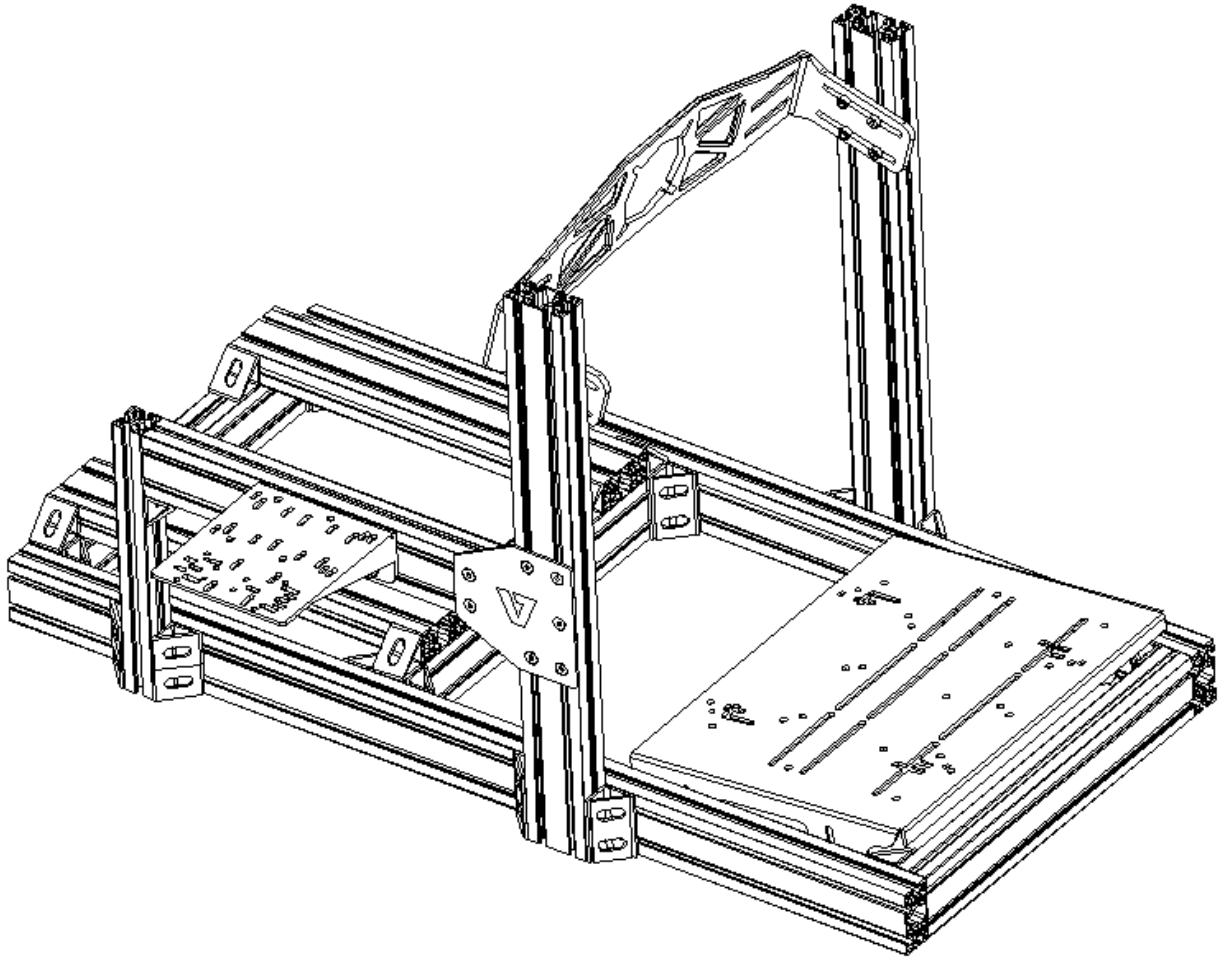



VNM SIMULATION .,JSC

2 x 4

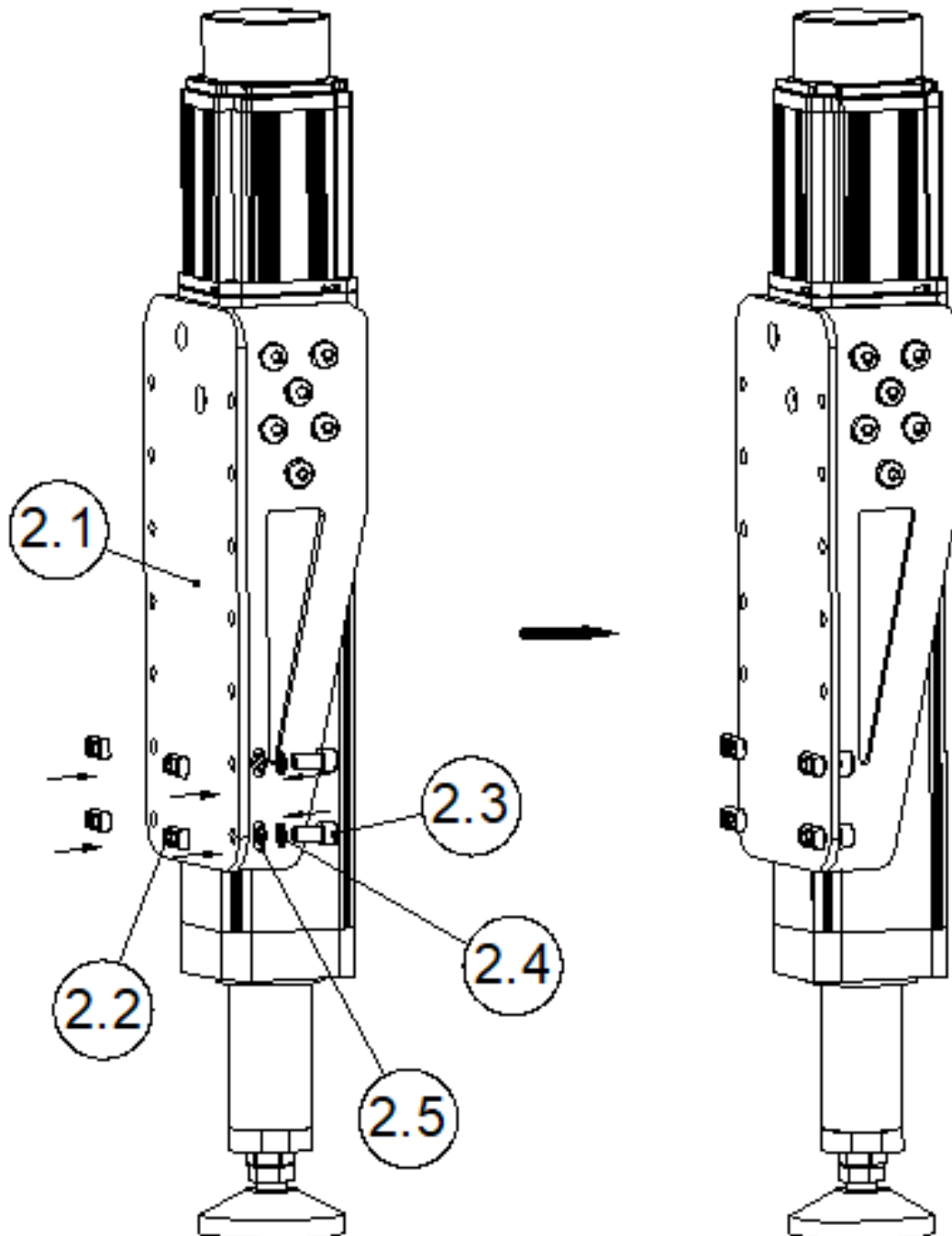



VNM SIMULATION .,JSC

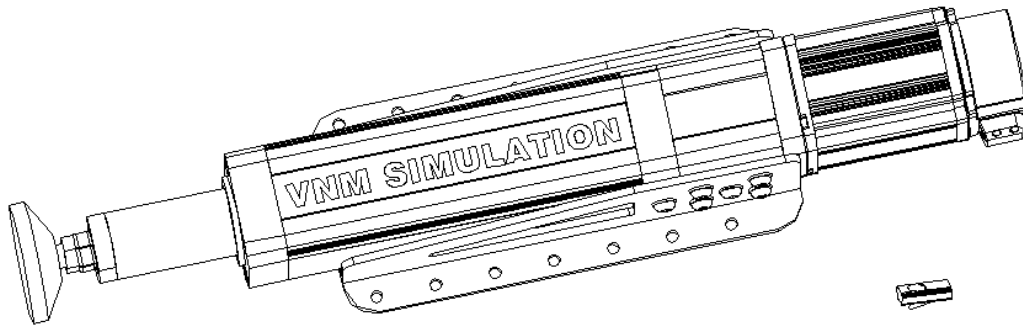

2.1 x1

Bộ gá Actuator trục dọc
VNM Actuator with U bracket



2.2 x4

Con trượt lấy M8
Nuts of profile M8



2.3 x4

Inox LGC M8x16
Hexagon Socket bolt M8x16



2.4 x4

Đệm vênh M8
Spring washer M8



2.5 x4

Đệm phẳng M8
Flat washer M8



4. Surge Actuator

Danh sách linh kiện của Surge Actuator/ Surge Actuator Part list				
STT/ NO	Tên/Part name	Mô tả/Description	Ghi chú/Note	Số lượng/ QTY
1	Actuator	VNM Actuator		1
2	Gá actuator trục surge Surge actuator L-bracket	80*70*60mm	Màu đen	2
3	Gá bi mắt trâu SA16 surge Surge actuator U-bracket	80*47*40mm	Màu đen	1
4	Đỡ gá bi mắt trâu SA16 surge Bracket for SA16	80*47*40mm	Màu đen	1
5	Bi mắt trâu Fish eye ball joint SA16	SA16		1
6	Đai ốc M16 Hexagon nut M16	M16	Inox	1
7	Đệm vênh Spring washer	M16		1
8	Bulong Inox đầu lục giác Hexagon ball M12*70	M12*70	Inox	1
9	Đệm phẳng Flat washer	M12		2
10	Đệm bi SA16 - 8mm SA16 washer – 8mm	Ø25*12*8mm	Inox	2
11	Đệm vênh Spring washer M12	M12		1
12	Đai ốc M12 Hexagon nut M12	M12	Inox	1
13	Inox LGC đầu mo Bolt LGC M8*16	M8*16	Inox	10
14	Inox LGC đầu trụ Bolt LGC M8*12	M8*12	Inox	2
15	Đệm vênh Spring washer	M8		12
16	Đệm phẳng Flat washer	M8		12



VNM SIMULATION.,JSC

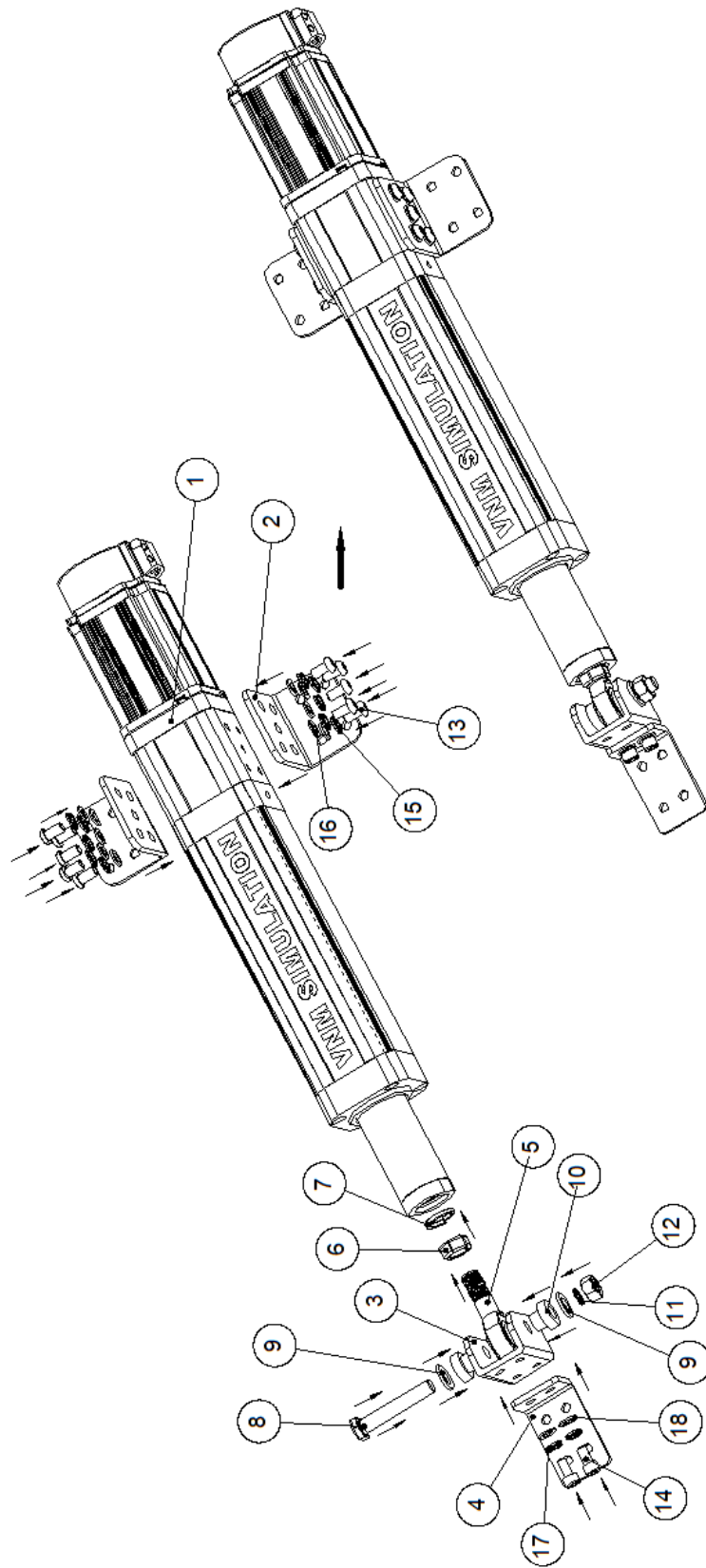



VNM SIMULATION .,JSC

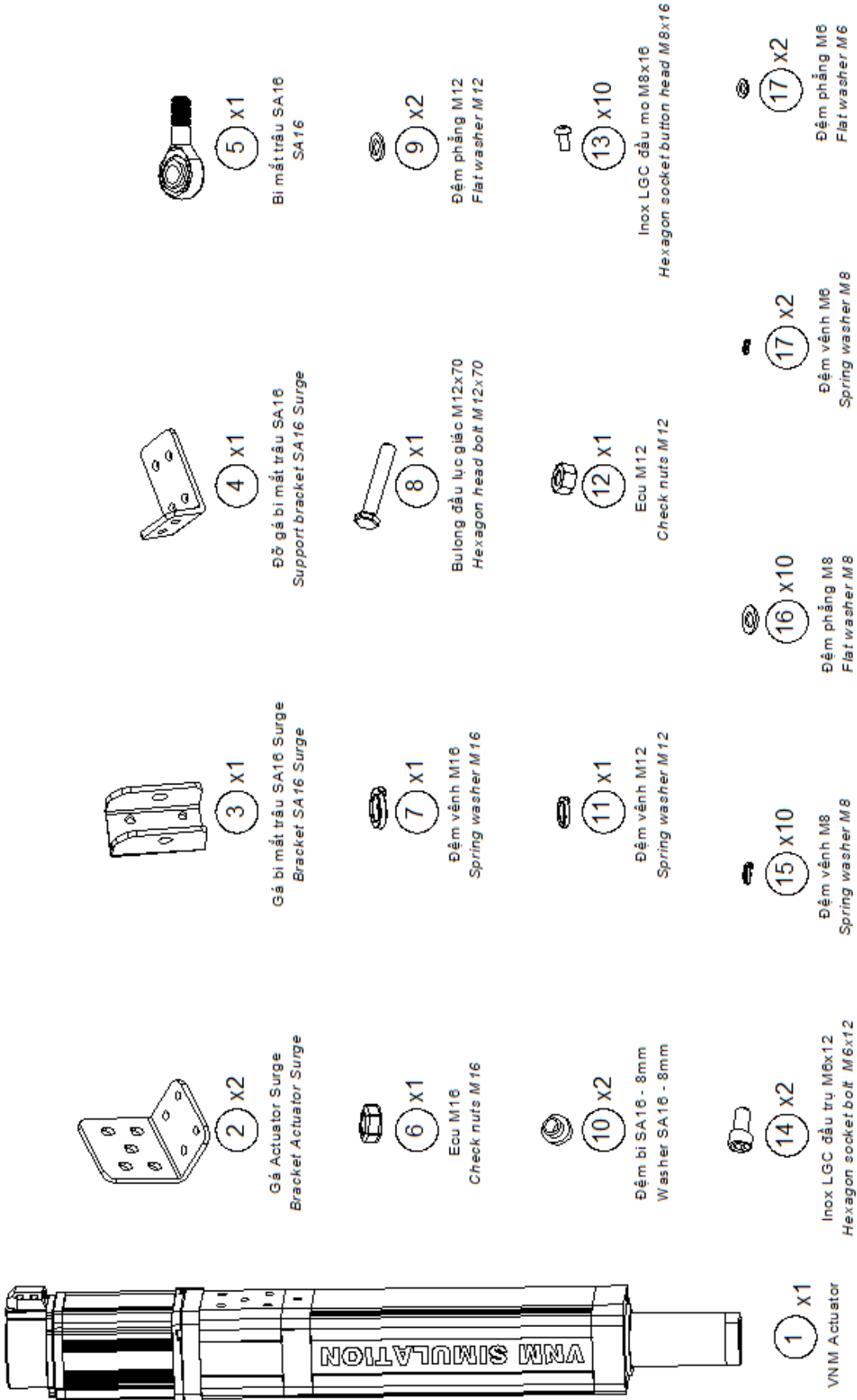



5. Traction loss Actuator

Danh sách linh kiện của Traction Loss Actuator/ Traction Loss Actuator Part list				
STT/ NO	Tên/Part name	Mô tả/Description	Ghi chú/Note	Số lượng/QTY
1	VNM Actuator			1
2	Bộ gá mắt trâu SA16 TL SA fish-eye joint set bracket for TL			1 bộ/set
3	Bộ gá servo motor TL Servo mount for TL			1 bộ/set
4	Inox LGC đầu mo Bolt LGC M8*16	M8*16mm		1
5	Đệm vênh Spring washer	M8		1
6	Đệm phẳng Flat washer	M8		1



VNM SIMULATION .,JSC

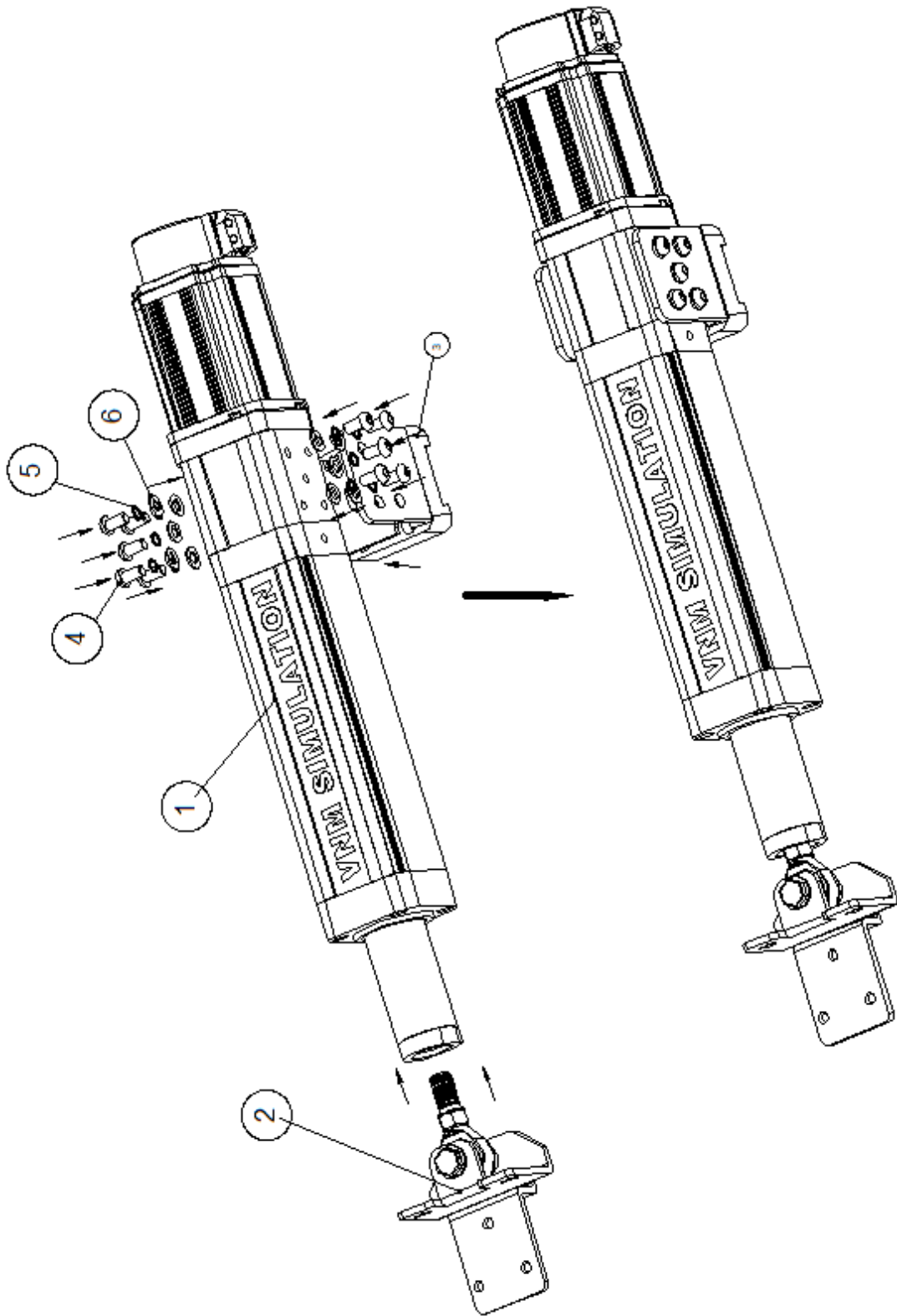



VNM SIMULATION .,JSC

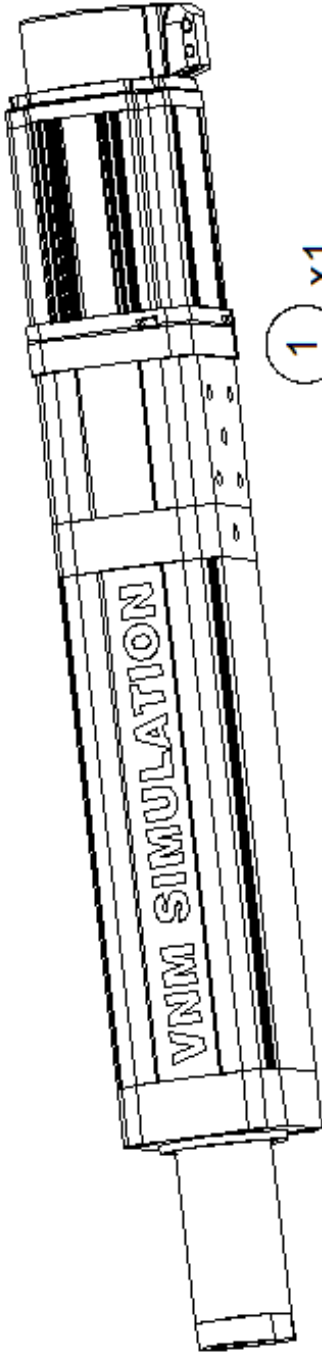

1 x1
VNM Actuator



2 x1

Bộ gá mắt trâu SA16 TL
Set bracket for SA16 TL

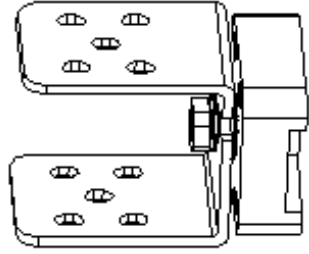

3 x1

Bộ gá servo motor TL
Set bracket for servo motor TL



4 x10

Inox LGC đầu mo M8x16
Hexagon socket button head M8x16



5 x10

Đệm vênh M8
Spring washer M8



6 x10

Đệm phẳng M8
Flat washer M8

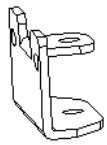
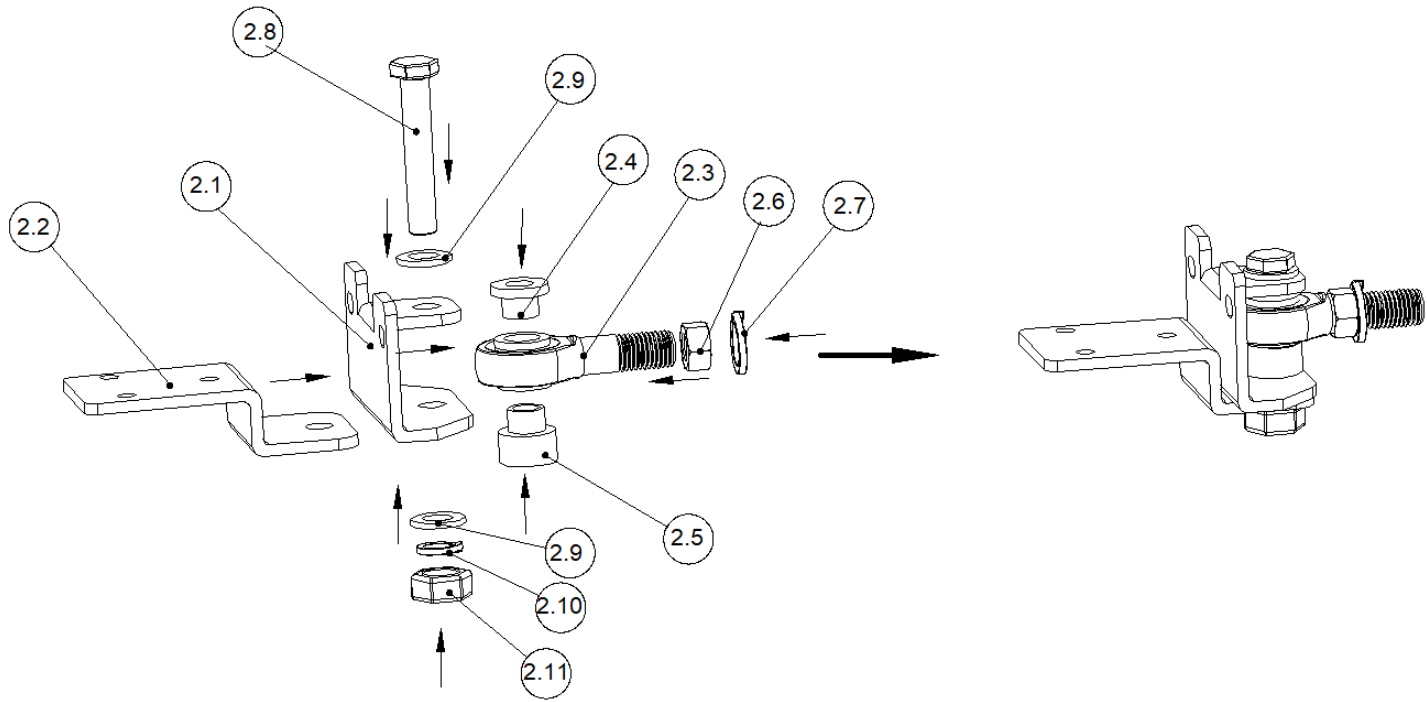

2.1 x1

Gá bi mắt trâu SA16 TL
Bracket SA16 TL



2.2 x1

Đỡ gá bi mắt trâu SA16
Support bracket SA16

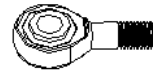

2.3 x1

Bi mắt trâu SA16
SA16



2.4 x1

Đệm bi SA16 - 4mm
Washer SA16 - 4mm



2.5 x1

Đệm bi SA16 - 13,5mm
Washer SA16 - 13,5mm



2.6 x1

Ecu M16
Check nuts M16



2.7 x1

Đệm vênh M16
Spring washer M16

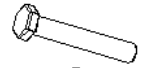

2.8 x1

Bulong đầu lục giác M12x70
Hexagon head bolt M12x70



2.9 x2

Đệm phẳng M12
Flat washer M12



2.10 x1

Đệm vênh M12
Spring washer M12



2.11 x1

Ecu M12
Check nuts M12



VNM SIMULATION .,JSC

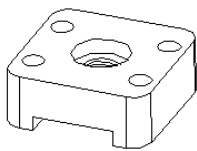
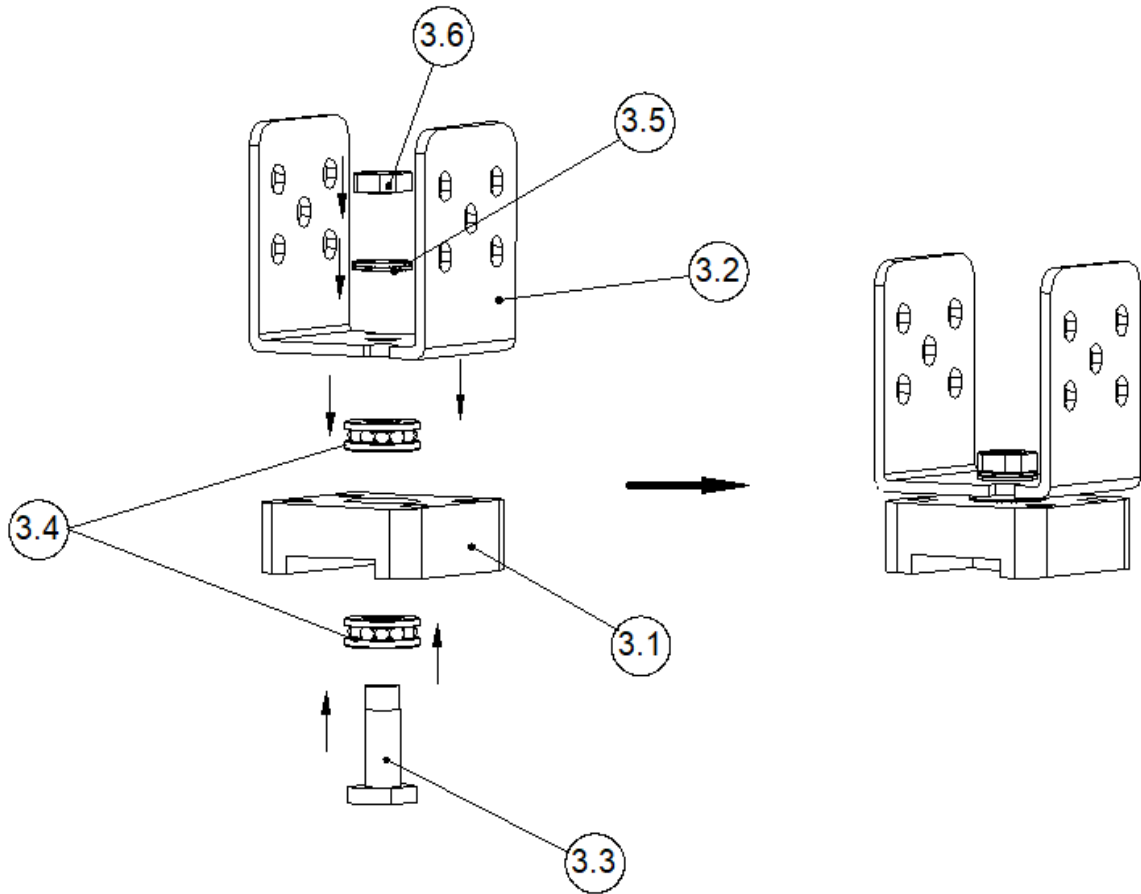

(3.1) x1

Bộ đỡ Actuator TL
Aluminum block with ball bearing

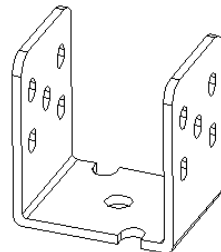

(3.2) x1

Khung gá Actuator TL
Bracket for Actuator TL

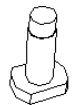

(3.3) x1

Trục xoay servo TL
Spindle servo TL



(3.4) x2

Vòng bi 51202
51502 bearing



(3.5) x1

Nordlock M14
Nordlock M14



(3.6) x1

Khóa ren Rn15
Spindle lock nut Rn15



6.1 Surge and 1 Traction loss Platform

6.1 Top Frame of Surge and Traction loss Platform (1/3)

Danh sách linh kiện của Top Frame of Surge and Traction loss Platform				
Top Frame of Surge and Traction loss Platform Part list				
STT /NO	Tên/Part name	Mô tả/Description	Ghi chú/Note	Số lượng/QTY
1	Nhôm định hình 40*80 / ALU extrusion 40*80	1140mm	Màu đen	2
2	Nhôm định hình 40*80 / ALU extrusion 40*80	720mm	Màu đen	2
3	Đế Motion D100/Actuator holder	Ø100mm		4
4	Bộ con trượt/Guideway HGH20			6 bộ/Set
5	Ke góc vuông/Conner bracket	40*40	Nhôm đen	4
6	Bộ part nối chữ I/ I bracket		Đen	4



VNM SIMULATION „JSC

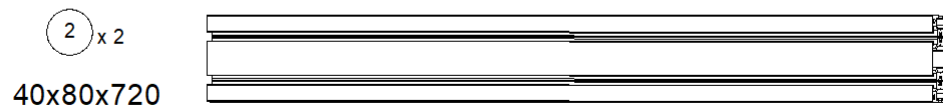
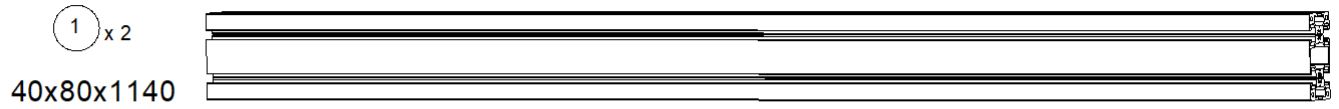
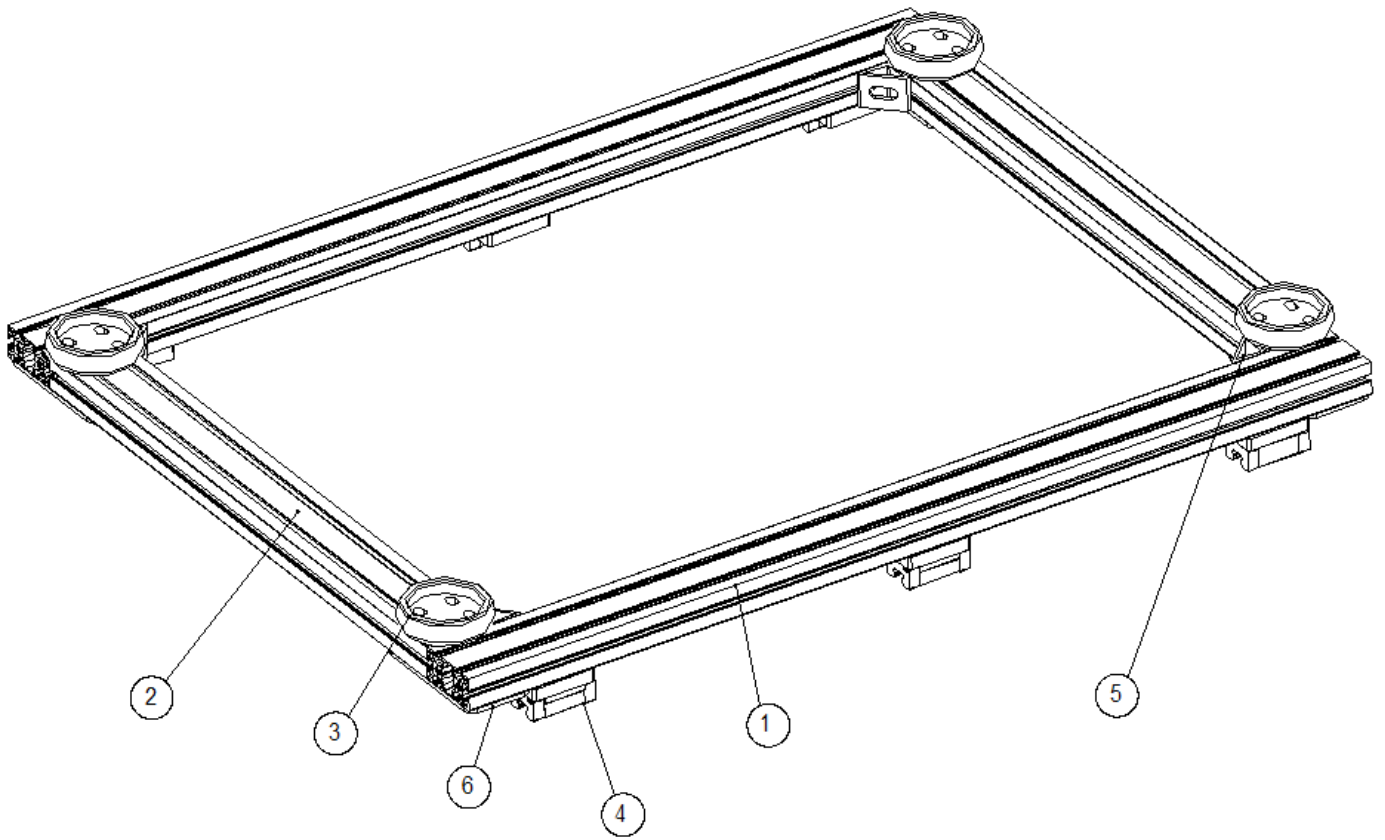



VNM SIMULATION .,JSC

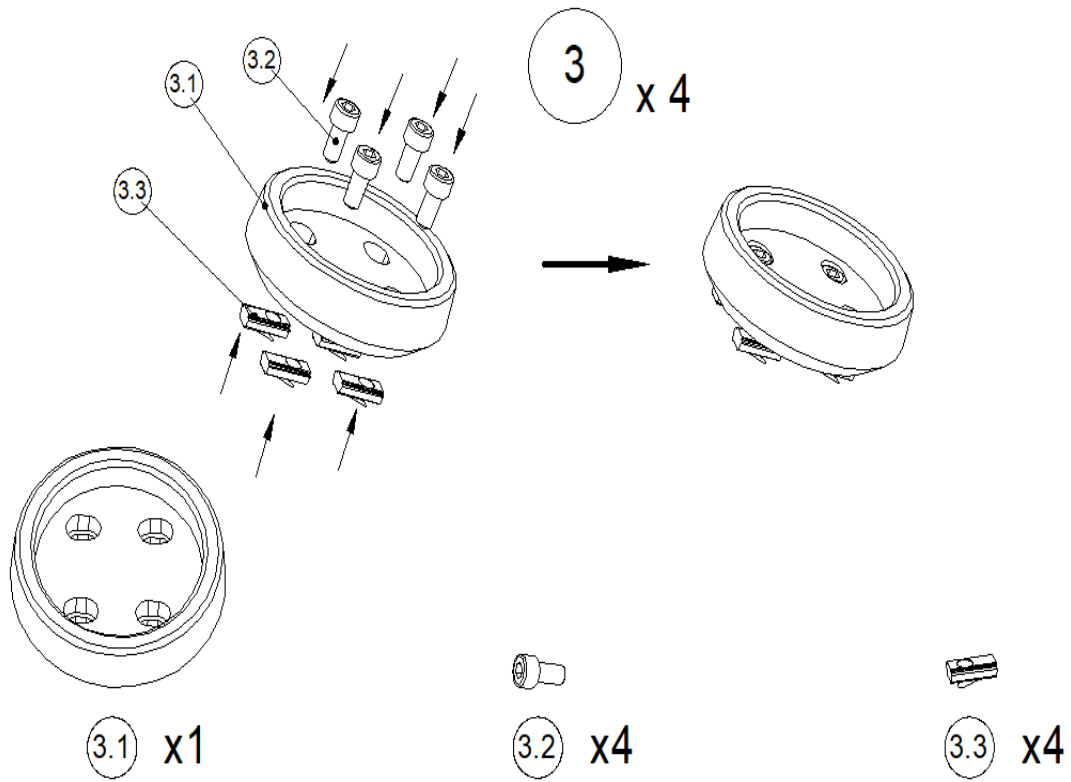

Đế motion D100
Pedestal motion D100

Inox LGC đầu trụ M8x16
Hexagon socket bolt M8x16

Con trượt lấy M8
Nuts of profile M8

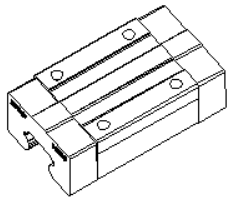
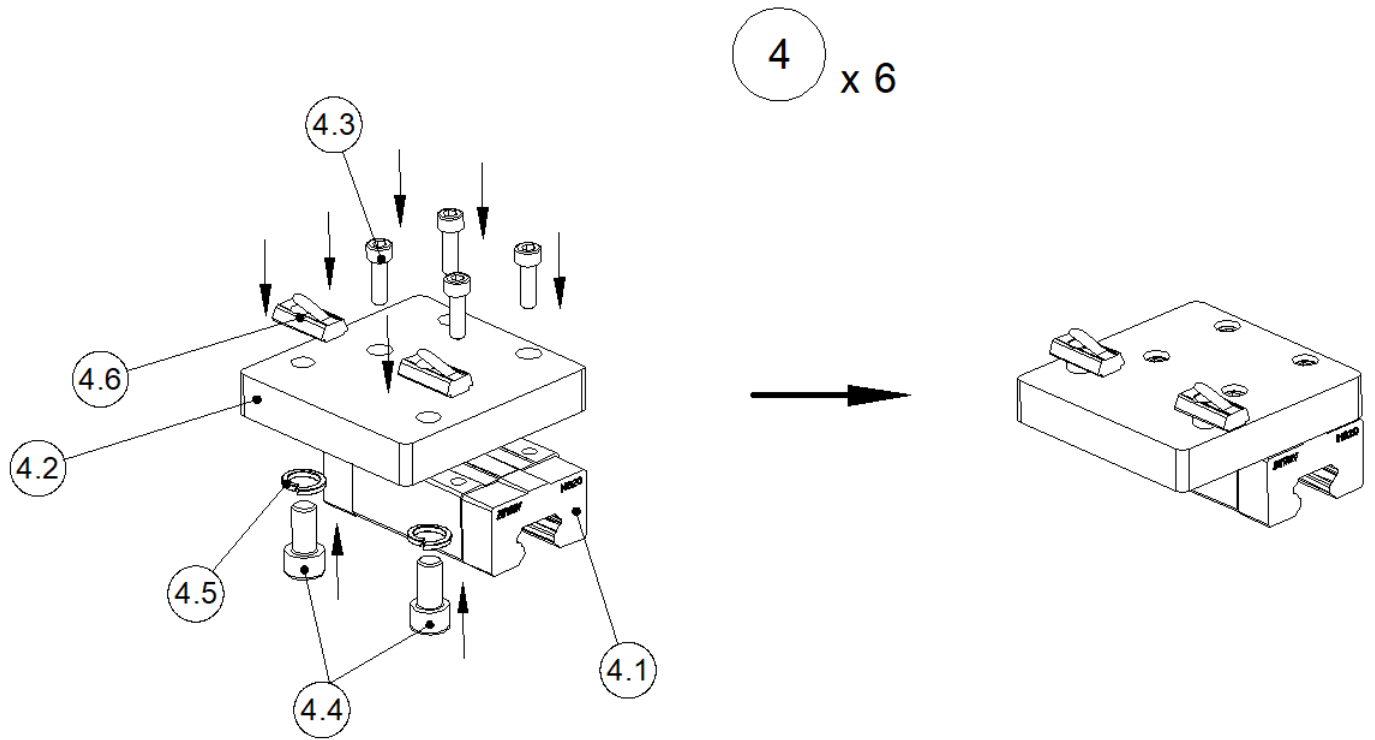

4.1 x1

Con trượt HGH20CA
Slider HGH20CA

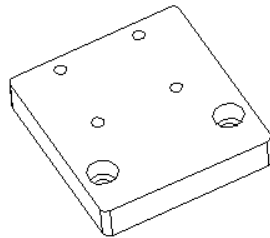

4.2 x1

Gá con trượt HGH20
Bracket for slider HGH20



4.3 x4

LGC đầu trụ M5x16
Hexagon socket bolt M5x16

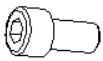

4.4 x2

Inox LGC M8x16
Hexagon Socket bolt M8x16



4.5 x2

Đệm vênh M8
Spring washer M8



4.6 x2

Con trượt lẫy M8
Nuts of profile M8



VNM SIMULATION .,JSC

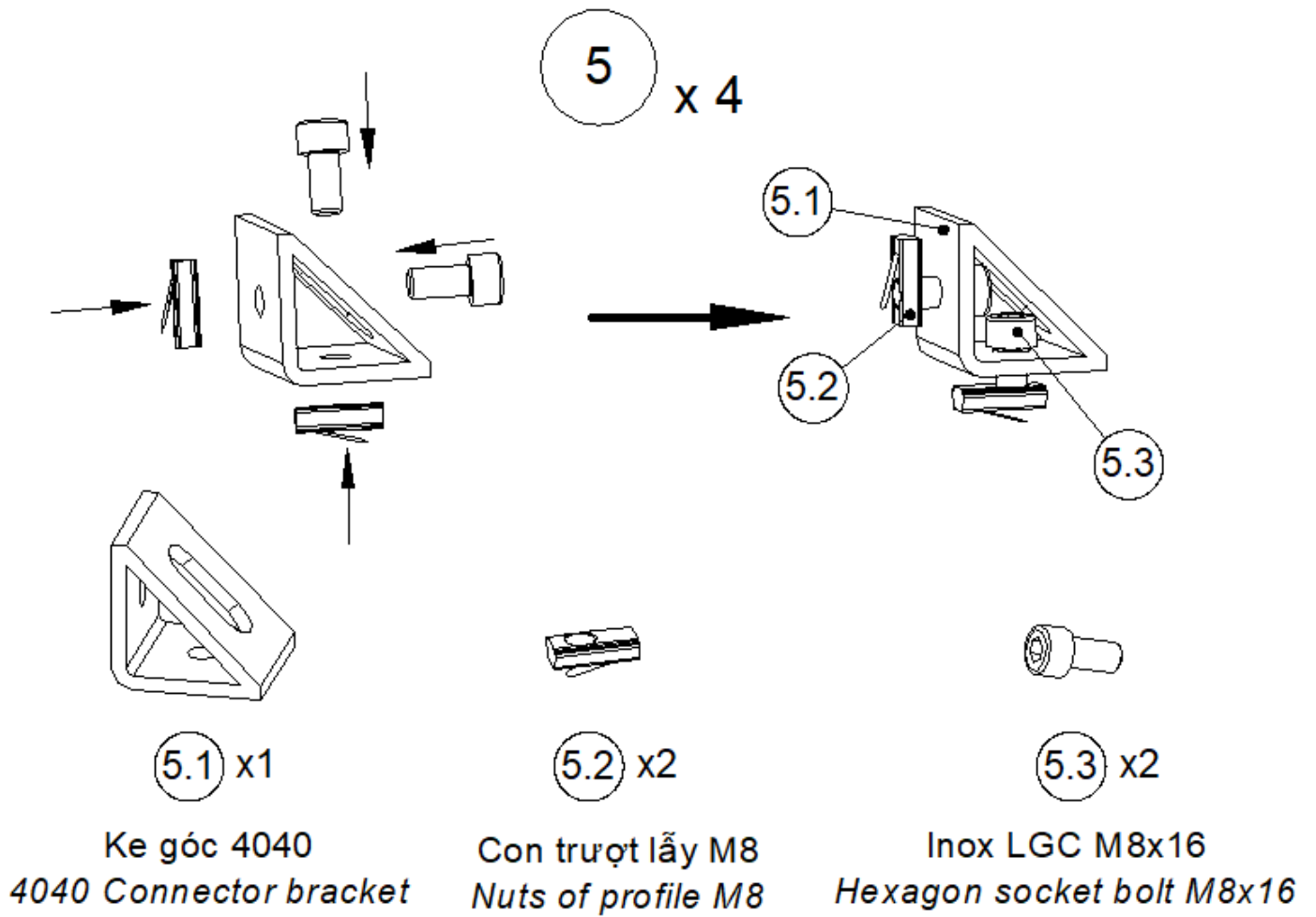

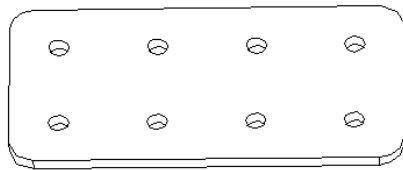
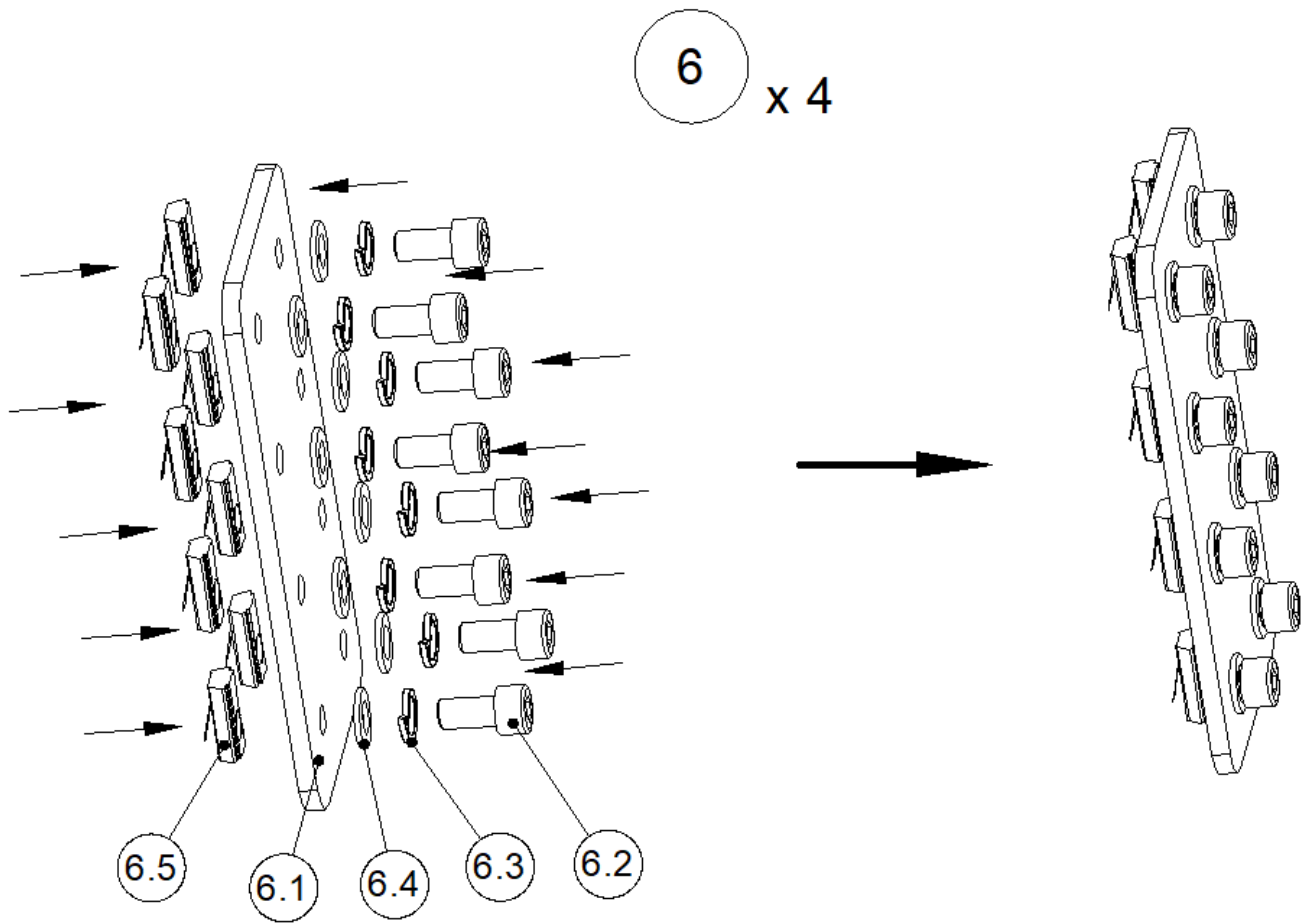

6.1 x1

Part nối chữ I
Connector plate I



6.2 x8

Inox LGC đầu trụ M8x16
Hexagon socket bolt M8x16



6.3 x8

Đệm vênh M8
Spring washer M8



6.4 x8

Đệm phẳng M8
Flat washer M8



6.5 x8

Con trượt lấy M8
Nuts of profile M8



VNM SIMULATION .,JSC



VNM SIMULATION .,JSC

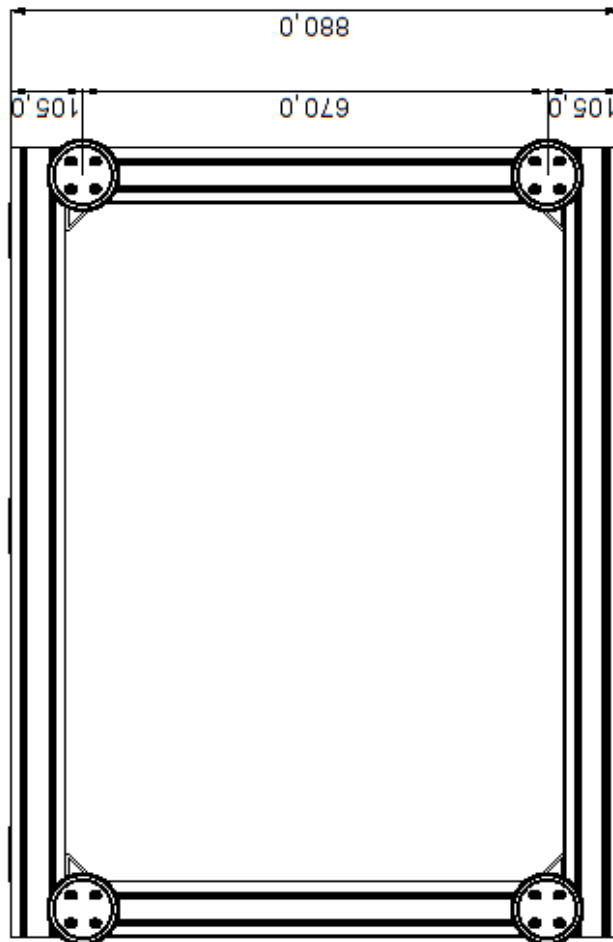
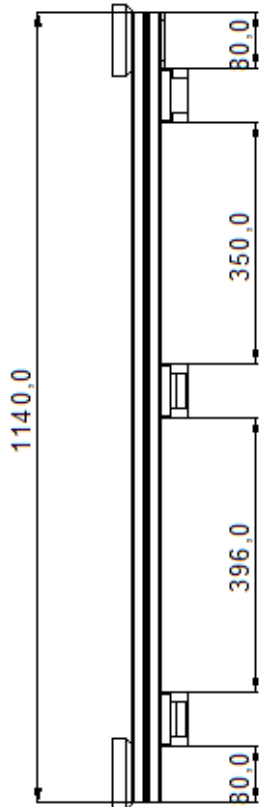



6.2. Middle Frame Surge và Traction loss platform 2/3

Danh sách linh kiện của Middle Frame of Surge and Traction loss Platform				
Middle Frame of Surge and Traction loss Platform Part list				
STT	Tên	Mô tả	Ghi chú	Số lượng
1	Nhôm định hình / Alu extrusion 40*80	1400mm	Màu đen	2
2	Nhôm định hình / Alu extrusion 40*80	800mm	Màu đen	3
3	Bộ gá Actuator cho trục Surge Surge actuator L-bracket			1 bộ
4	Thanh ray HGR20 / HGR20 rail	1,3m		2
5	Ke góc / Conner bracket 40*40			8
6	Part nối chữ I / I bracket			2
7	Bộ gối đỡ UCFL-204 / UCFL-204 Ball bearing units			1
8	Bộ bánh xe lăn/ gravity-caster set			4

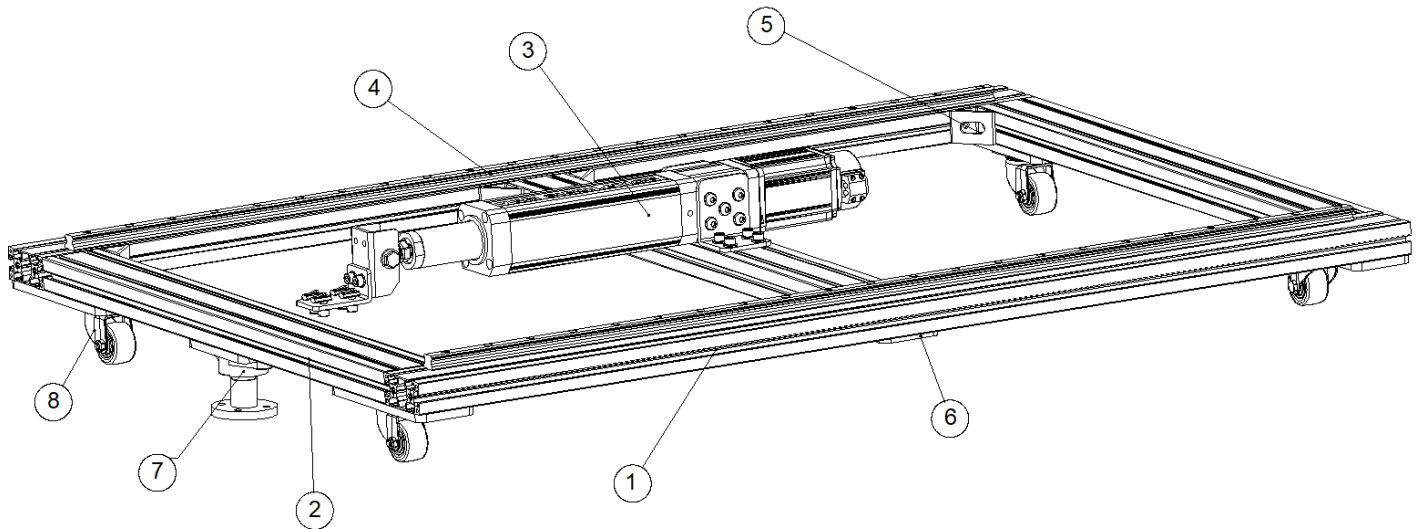



VNM SIMULATION .,JSC

① x 2

40x80x1400

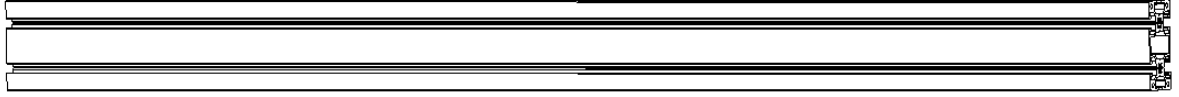

② x 3

40x80x800

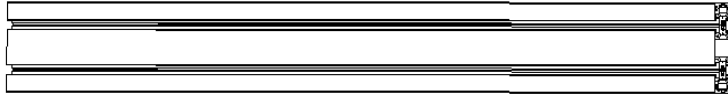



VNM SIMULATION .,JSC

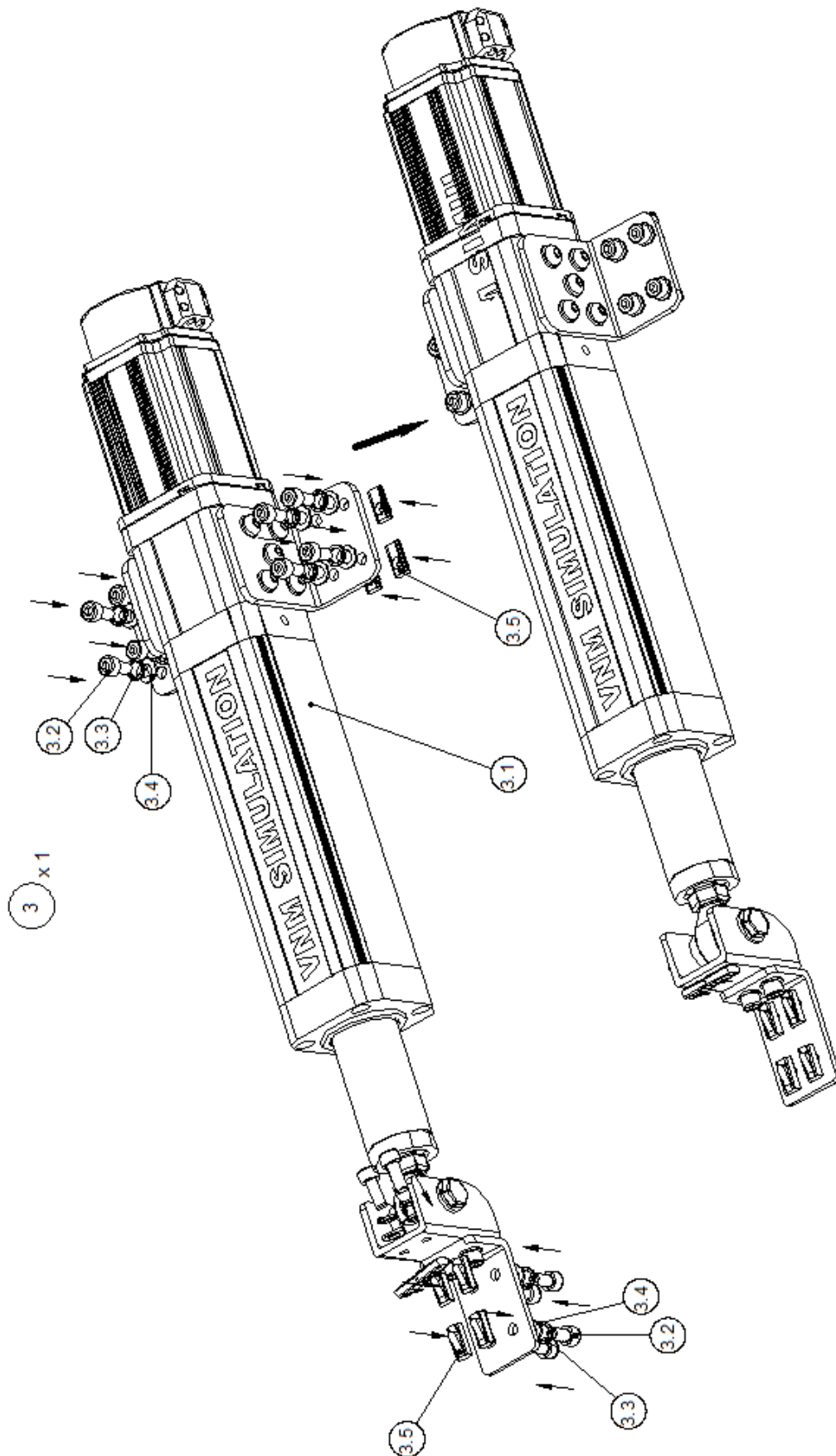



VNM SIMULATION .,JSC

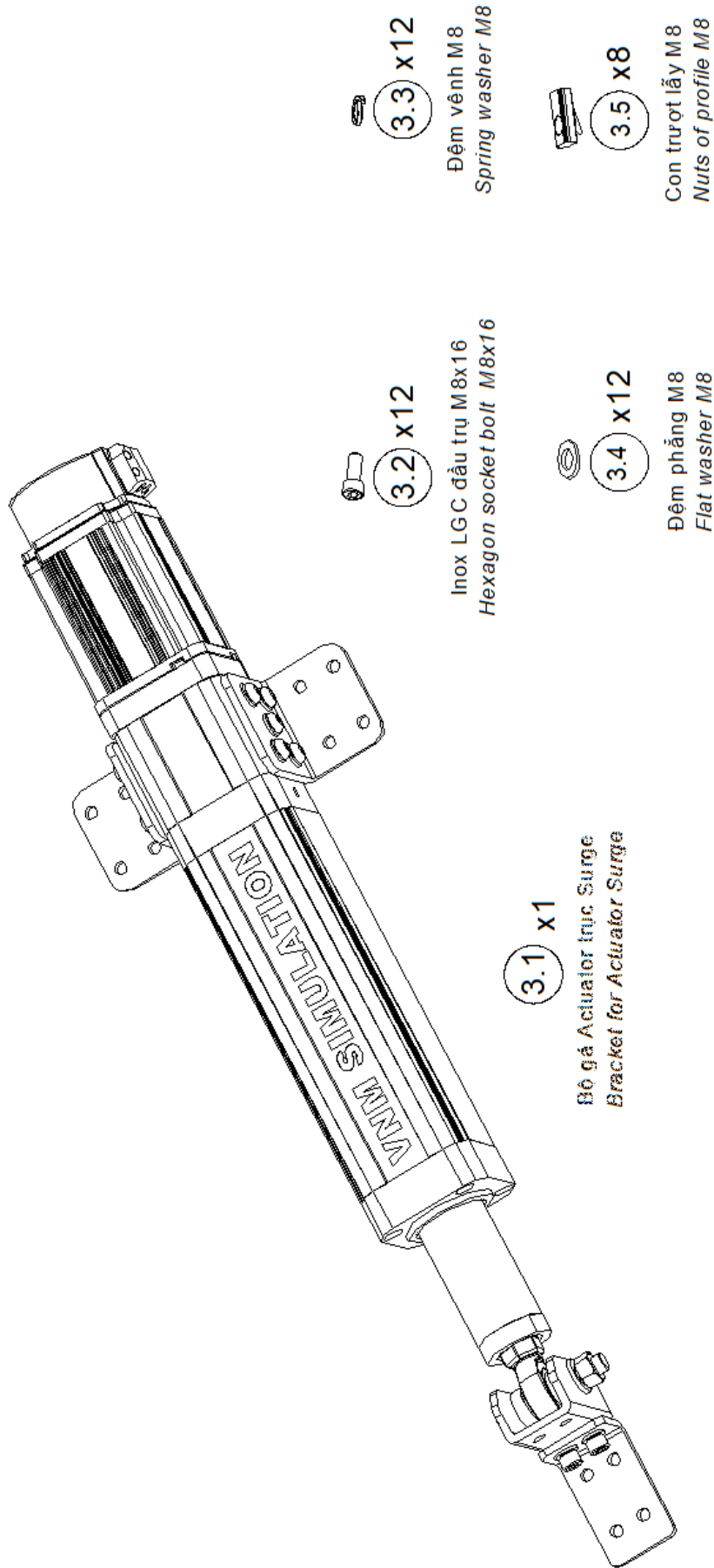

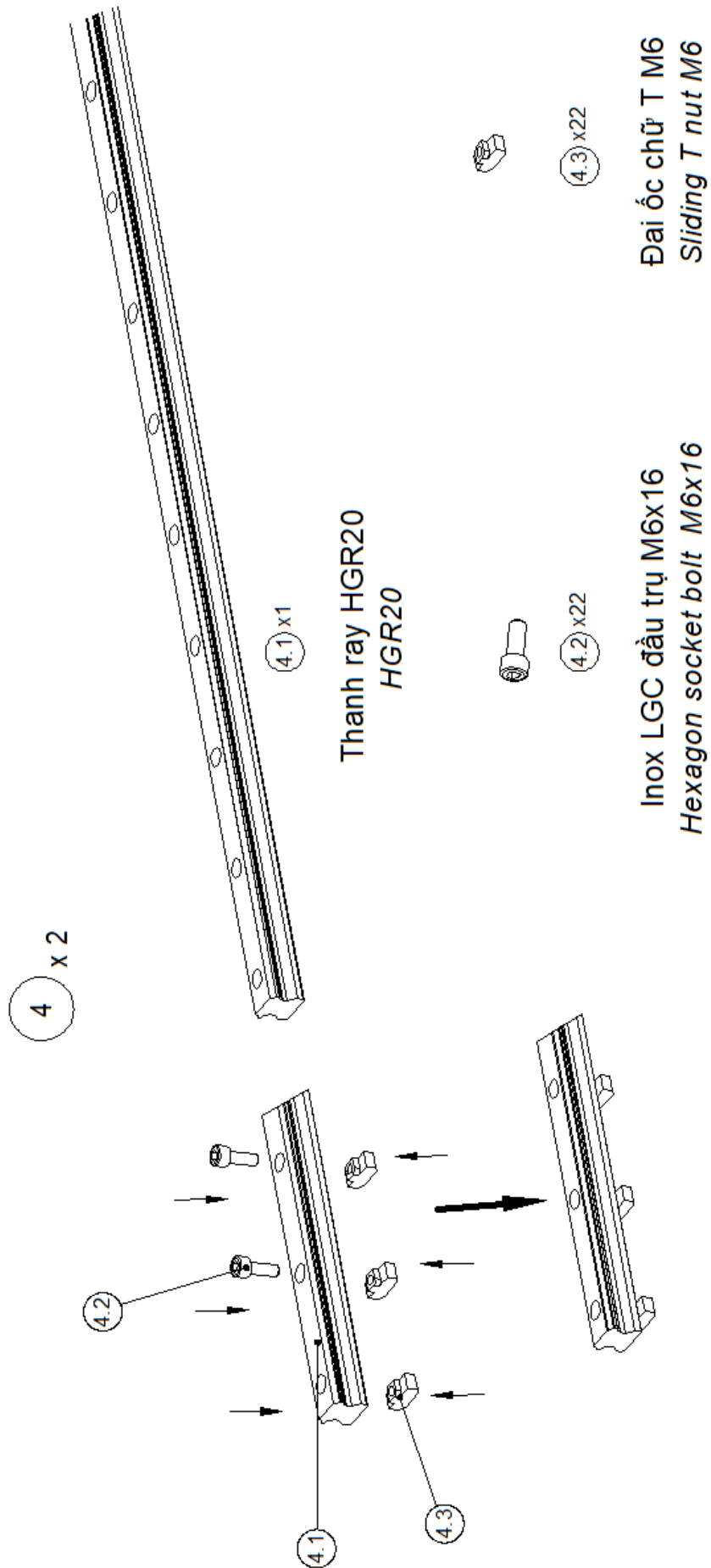



VNM SIMULATION .,JSC

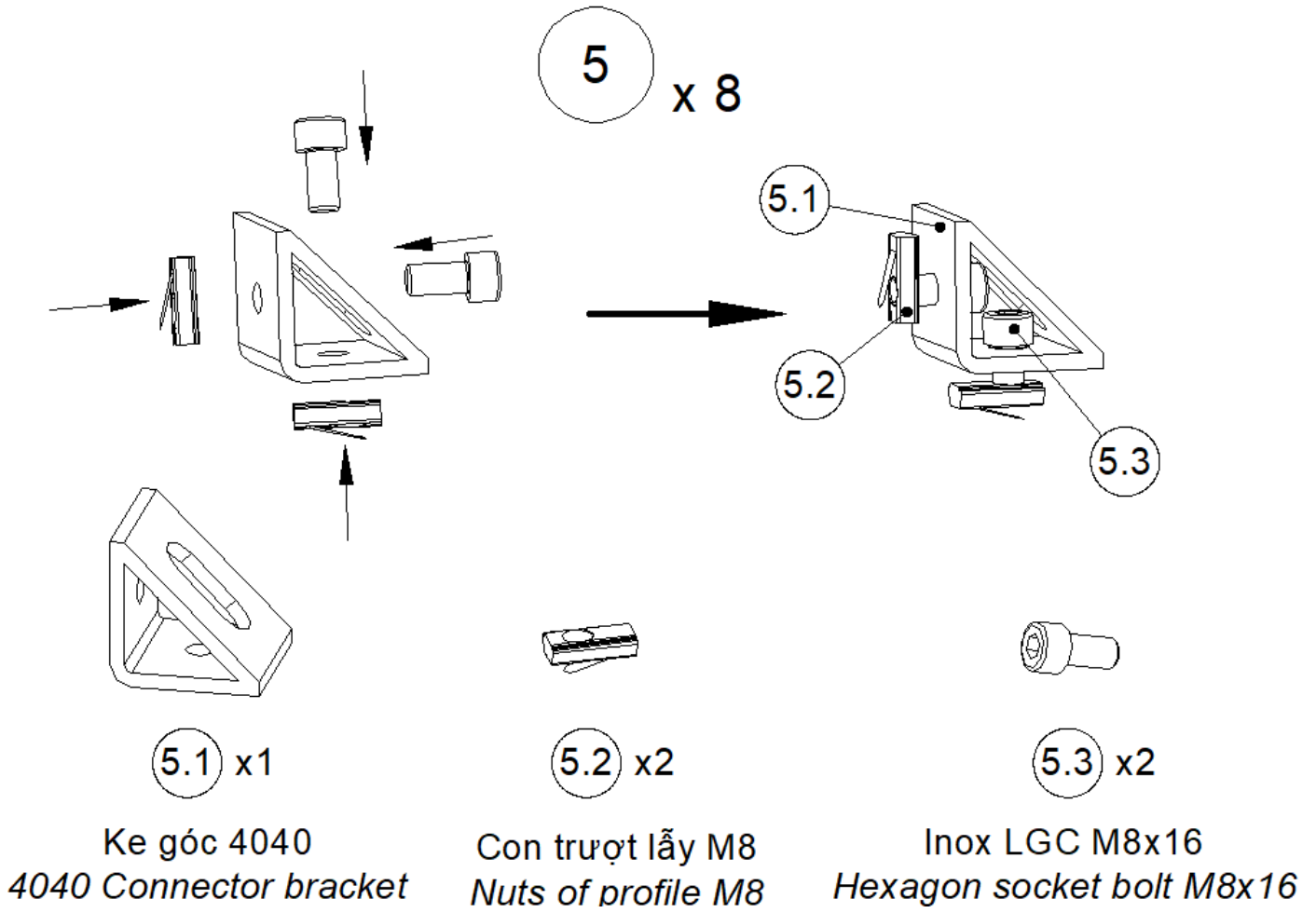

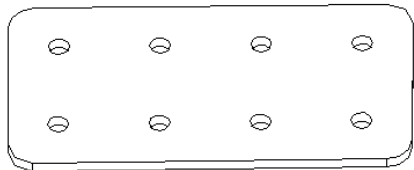
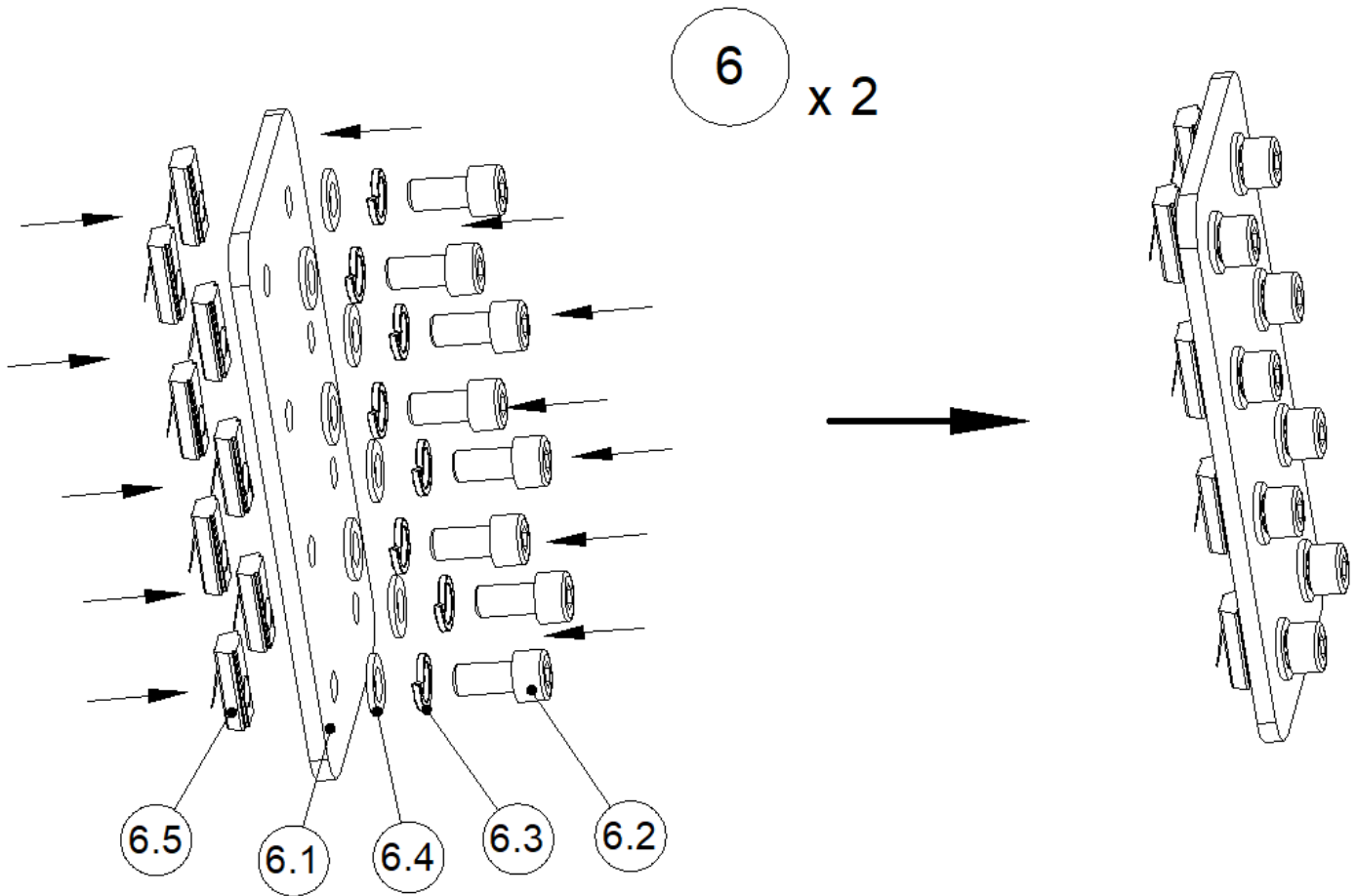

6.1 x1

Part nối chữ I
Connector plate I



6.2 x8

Inox LGC đầu trụ M8x16
Hexagon socket bolt M8x16



6.3 x8

Đệm vênh M8
Spring washer M8



6.4 x8

Đệm phẳng M8
Flat washer M8



6.5 x8

Con trượt lẫy M8
Nuts of profile M8



7 x 1

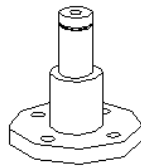
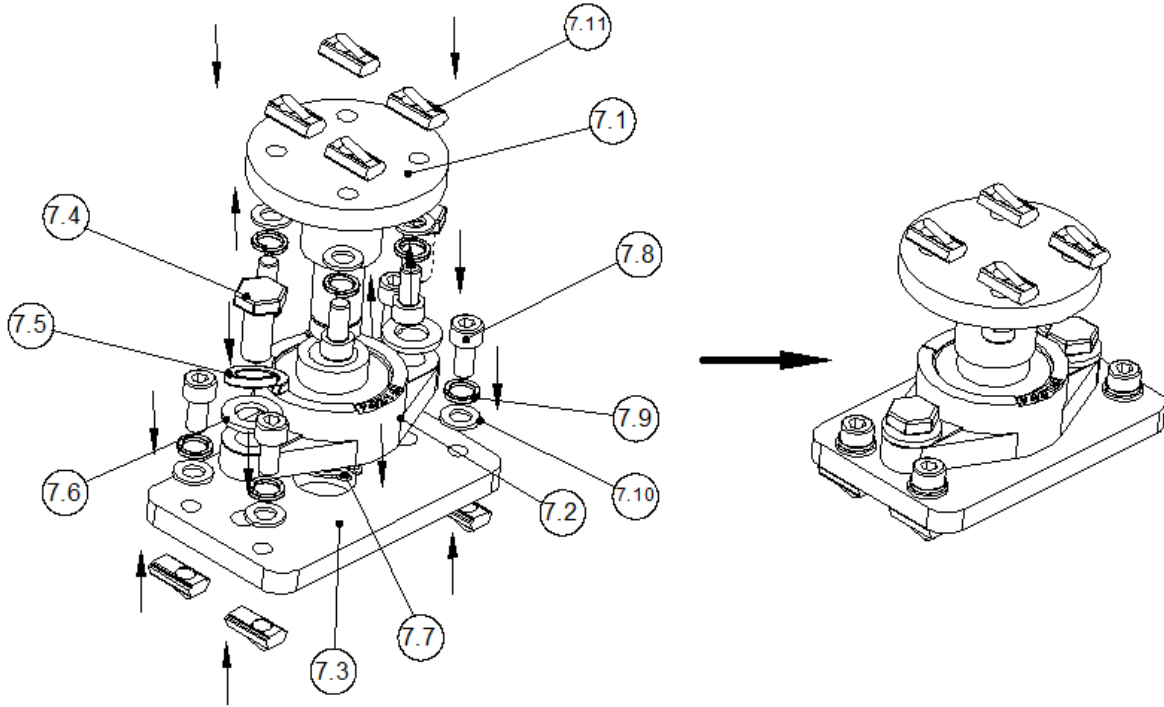

7.1 x1

Cụm trục xoay TL
Spindle TL

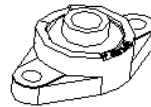

7.2 x1

Vòng bi UCFL - 204
Bearing holder UCFL - 204

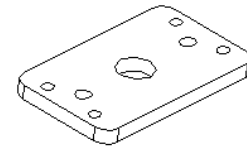

7.3 x1

Gối đỡ UCFL - 204
Bracket for bearing holder



7.4 x2

Bulong Inox đầu lục giác M12x25
Hexagon head bolt M12x25



7.5 x12

Đệm vênh M12
Spring washer M12



7.6 x12

Đệm phẳng M12
Flat washer M12



7.7 x12

Phanh trục chữ C D20
C-Shaped retaining ring D20



7.8 x2

Inox LGC đầu trụ M8x20
Hexagon socket bolt M8x20



7.9 x12

Đệm vênh M8
Spring washer M8



7.10 x12

Đệm phẳng M8
Flat washer M8



7.11 x8

Con trượt lấy M8
Nuts of profile M8



VNM SIMULATION .,JSC

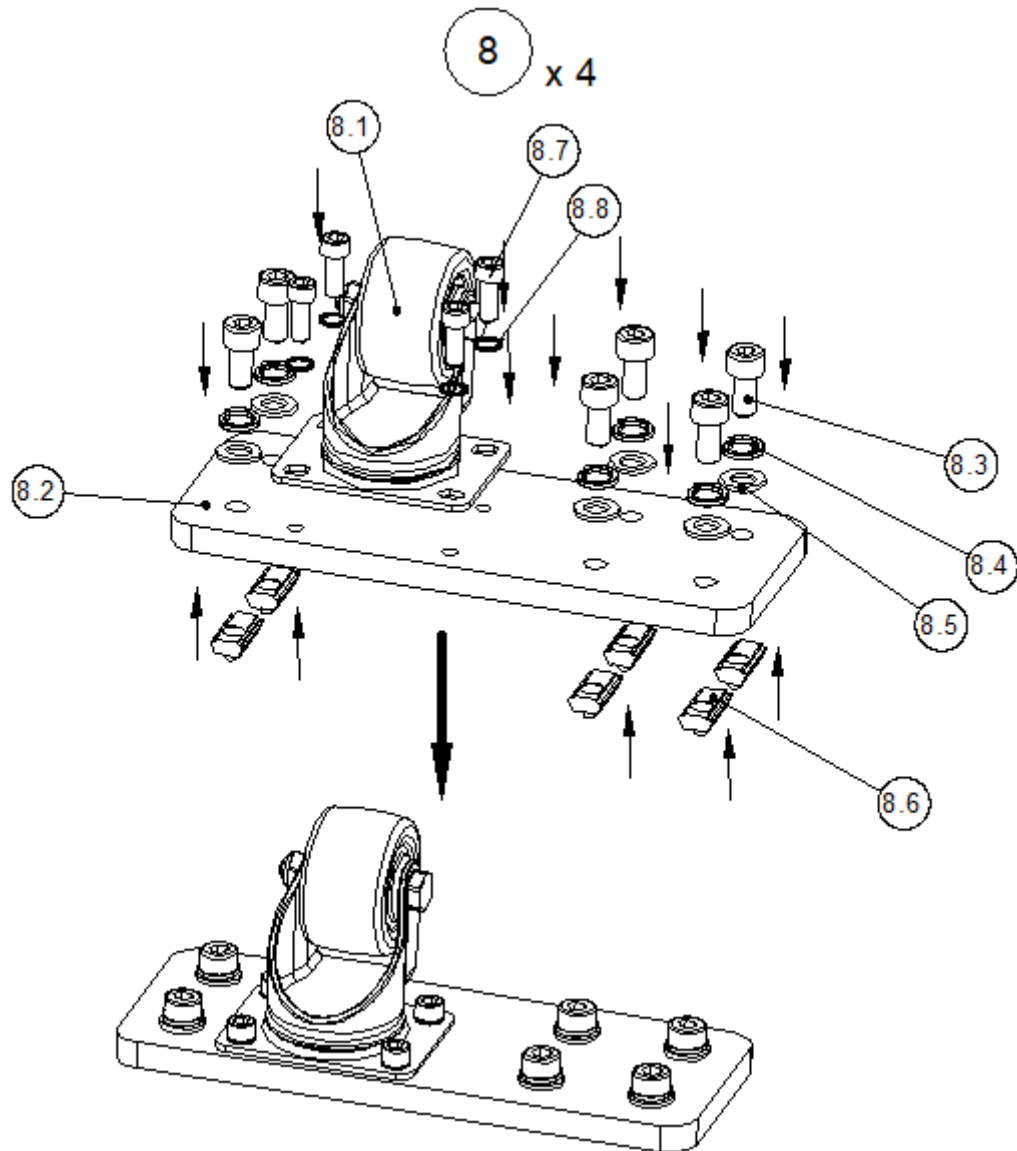

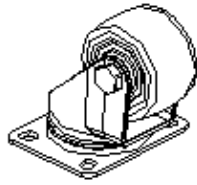

8.1 x1

Bánh xe low gravity
Low gravity wheels

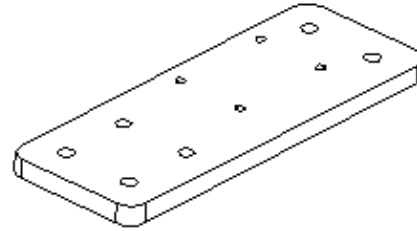

8.2 x1

Đế gá bánh xe
Bracket wheels



8.3 x6

Inox LGC đầu trụ M8x20
Hexagon socket bolt M8x20



8.4 x6

Đệm vênh M8
Spring washer M8



8.5 x6

Đệm phẳng M8
Flat washer M8



8.6 x6

Con trượt lẫy M8
Nuts of profile M8



8.7 x4

Inox LGC đầu trụ M6x12
Hexagon socket bolt M6x12



8.8 x4

Đệm vênh M6
Spring washer M6



VNM SIMULATION .,JSC

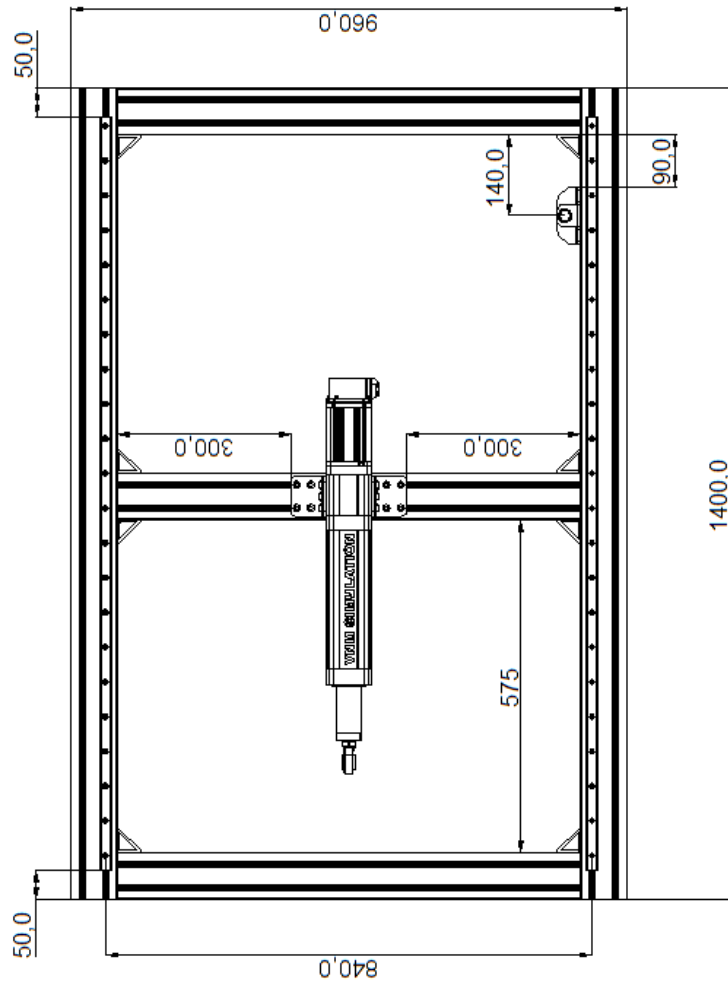
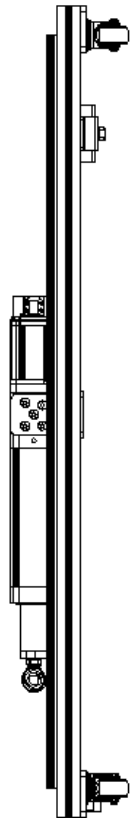
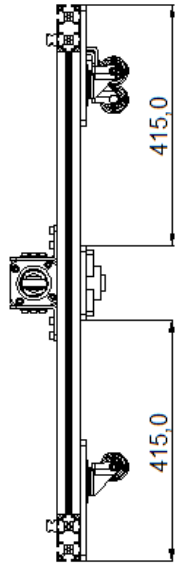



6.3. Bottom Frame fro Surge và Traction loss 3/3

Danh sách linh kiện của Bottom Frame of Surge and Traction loss Platform				
Bottom Frame of Surge and Traction loss Platform Part list				
ST T	Tên/ Part Name	Mô tả/Description	Ghi chú/Note	Số lượng/QT Y
1	Nhôm định hình / ALU extrusion 40*80	1400mm		2
2	Nhôm định hình / ALU extrusion 40*80	800mm		3
3	VNM Actuator			1 bộ/set
4	Đế lăn bánh xe / pad for gravity caster			4
5	Ke góc vuông / Conner bracket	40*40*38		8
6	Part nối chữ I/ I bracket			2
7	Bộ gá chân đế Motion/ Motion foot set			4 bộ/set

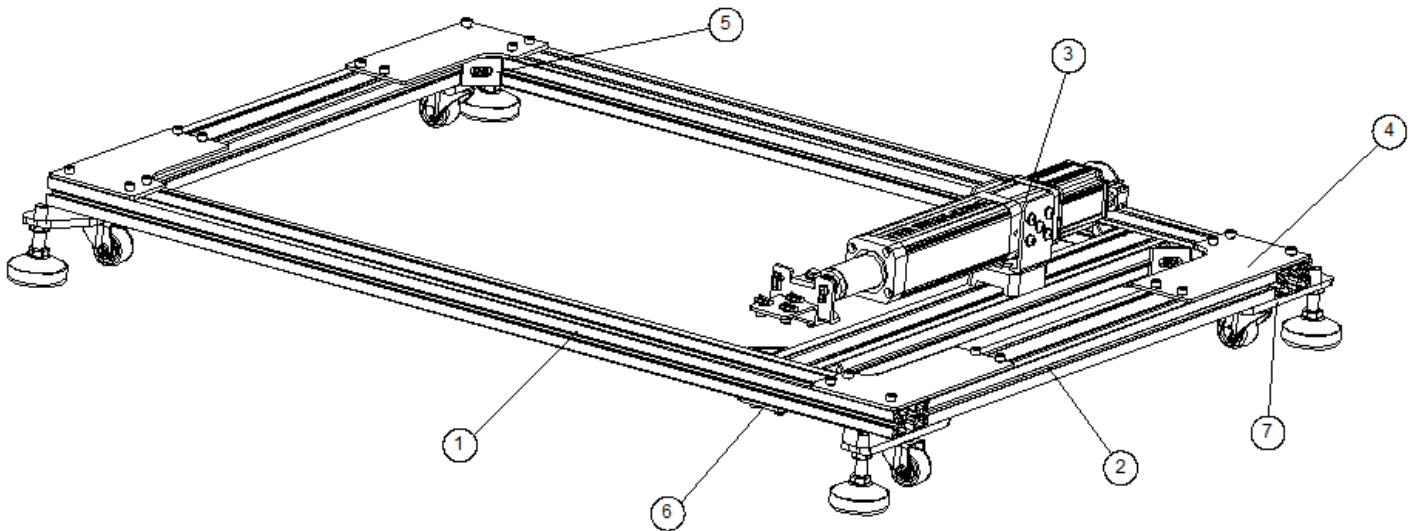



VNM SIMULATION „JSC

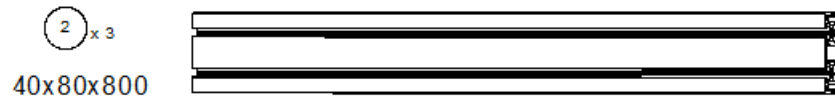
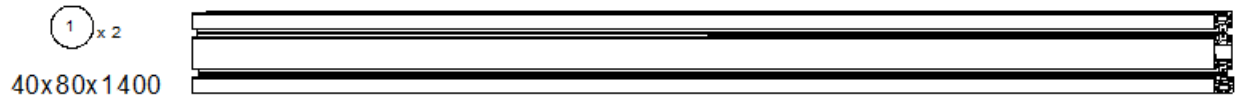



VNM SIMULATION .,JSC

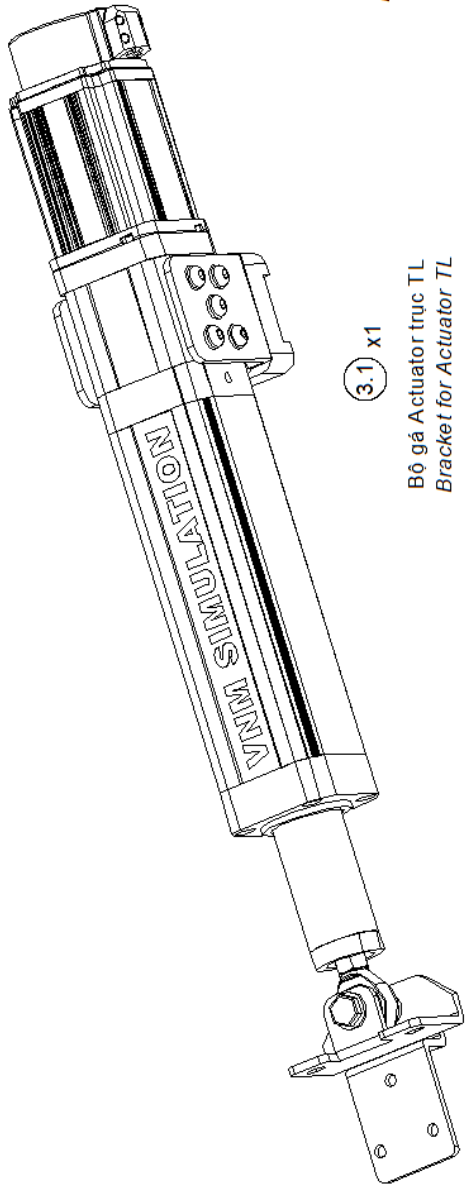

3.1 x1

Bộ gá Actuator trục TL
Bracket for Actuator TL



3.2 x5

Inox LGC đầu trụ M8x16
Hexagon socket bolt M8x16



3.3 x5

Đệm vênh M8
Spring washer M8



3.5 x5

Con trượt lấy M8
Nuts of profile M8



3.4 x5

Đệm phẳng M8
Flat washer M8

A x1

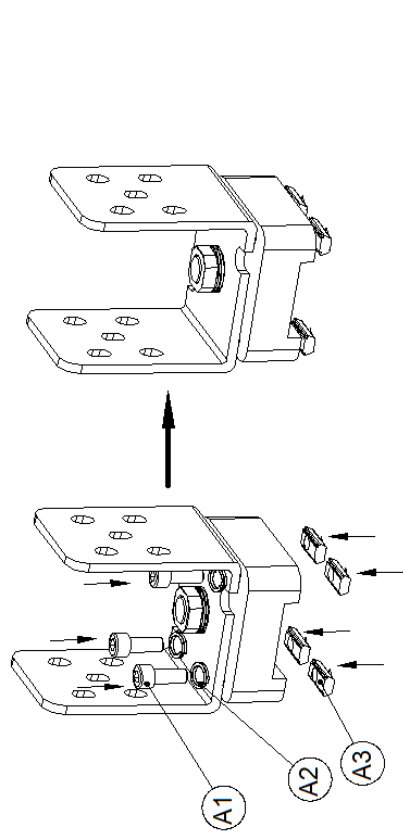

A1 x4

Inox LGC đầu trụ M8x20
Hexagon socket bolt M8x20



A2 x4

Đệm vênh M8
Spring washer M8



A3 x4

Con trượt lấy M8
Nuts of profile M8

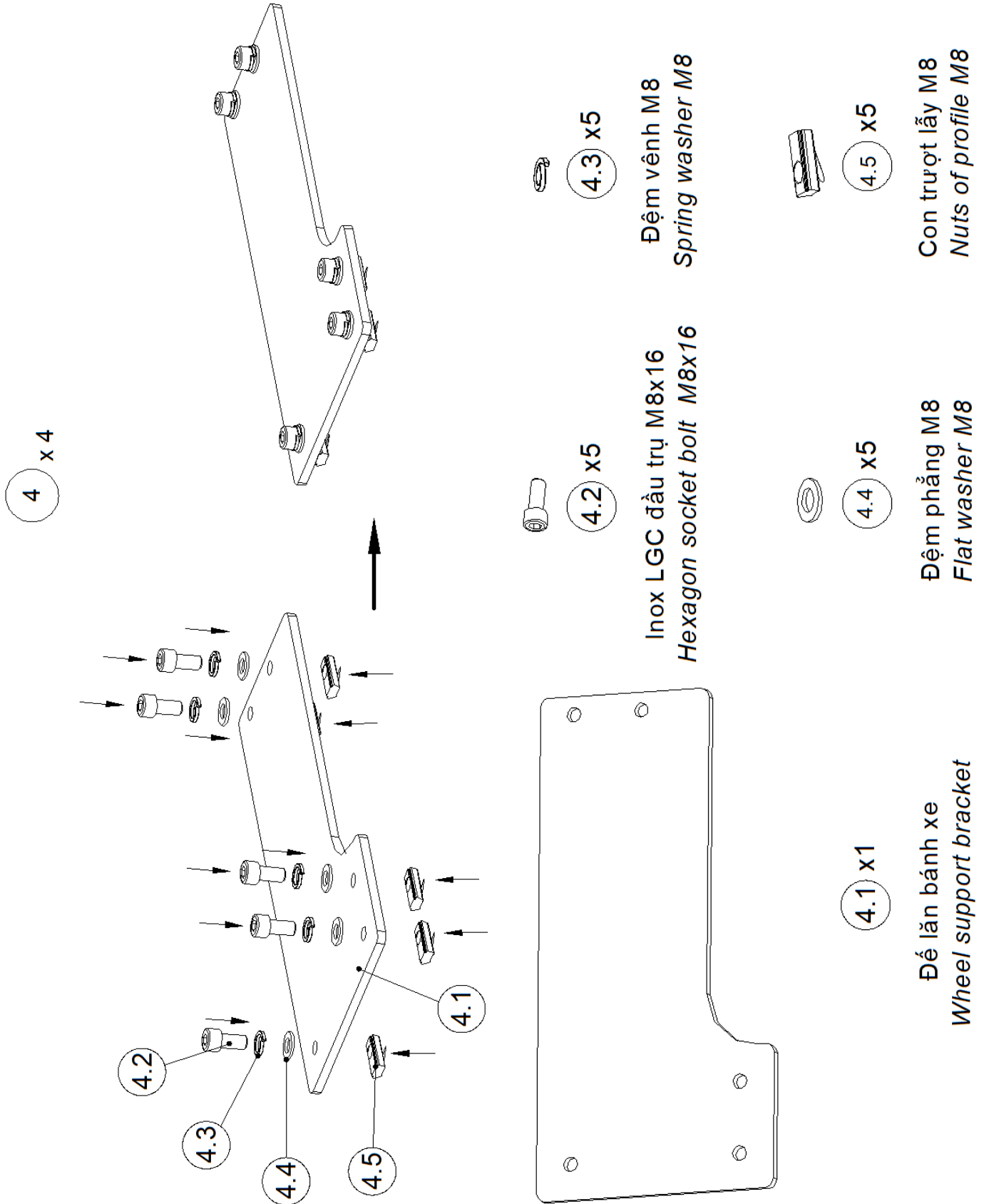



VNM SIMULATION .,JSC

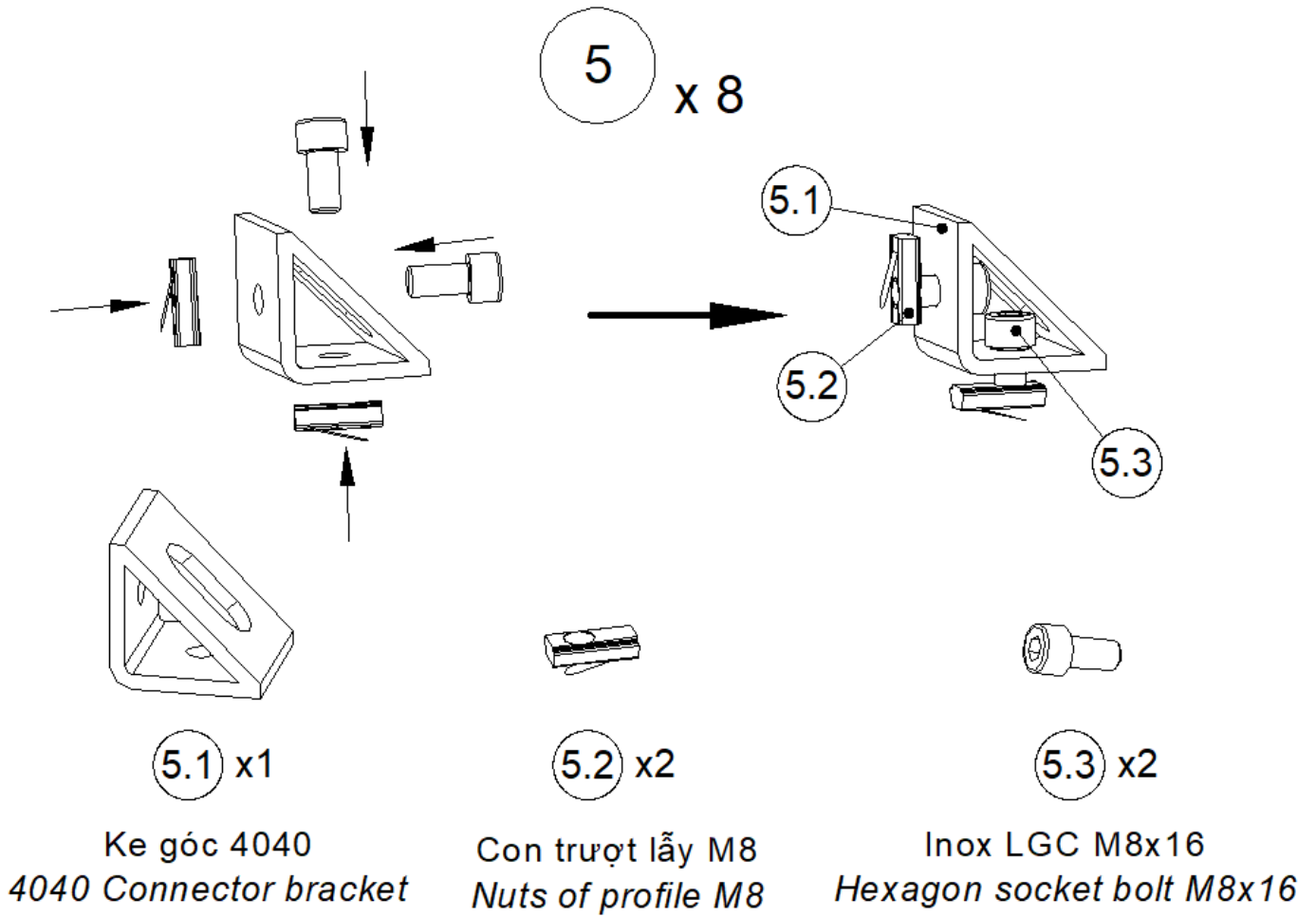

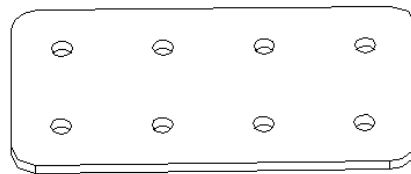
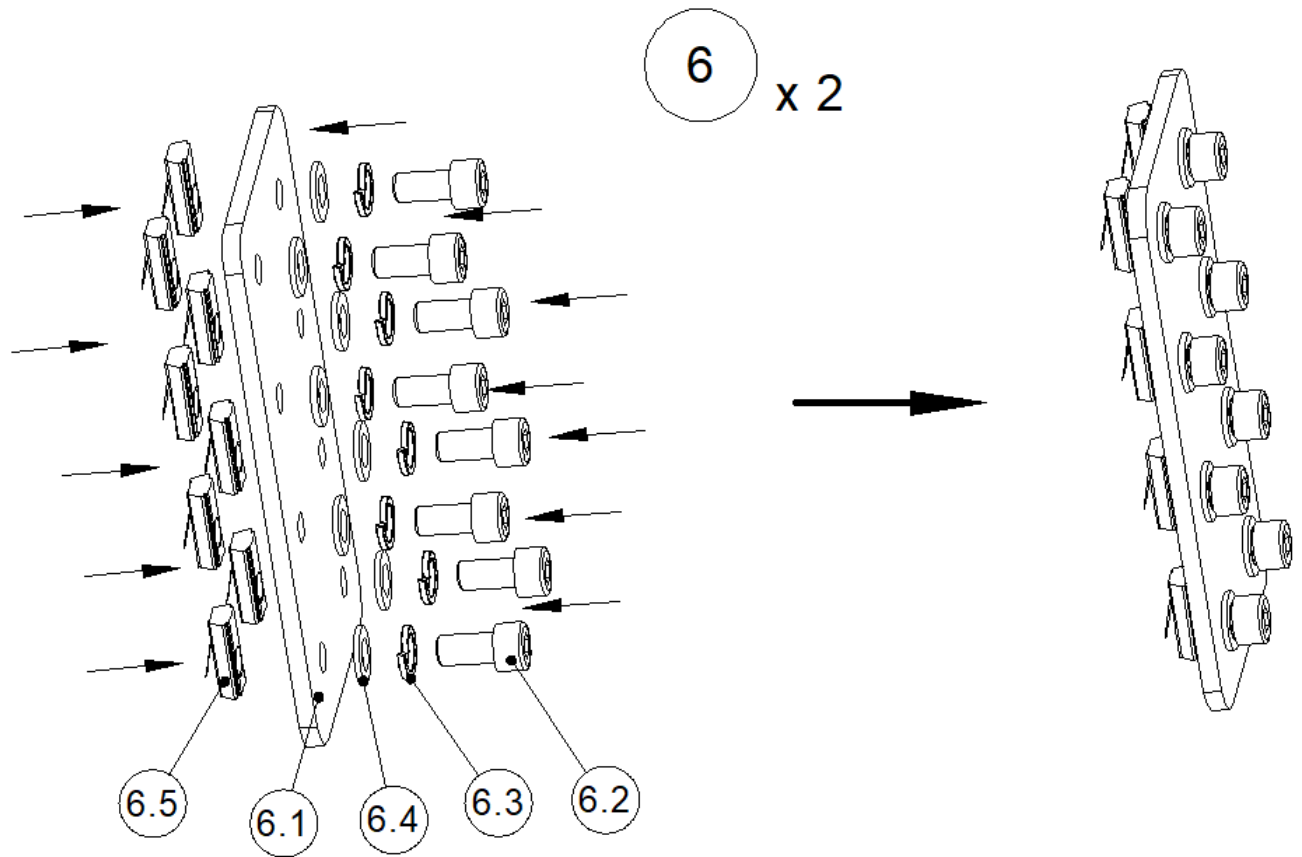

6.1 x1

Part nối chữ I
Connector plate I



6.2 x8

Inox LGC đầu trụ M8x16
Hexagon socket bolt M8x16



6.3 x8

Đệm vênh M8
Spring washer M8



6.4 x8

Đệm phẳng M8
Flat washer M8



6.5 x8

Con trượt lấy M8
Nuts of profile M8



VNM SIMULATION .,JSC

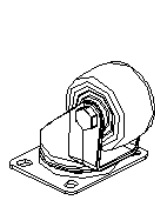
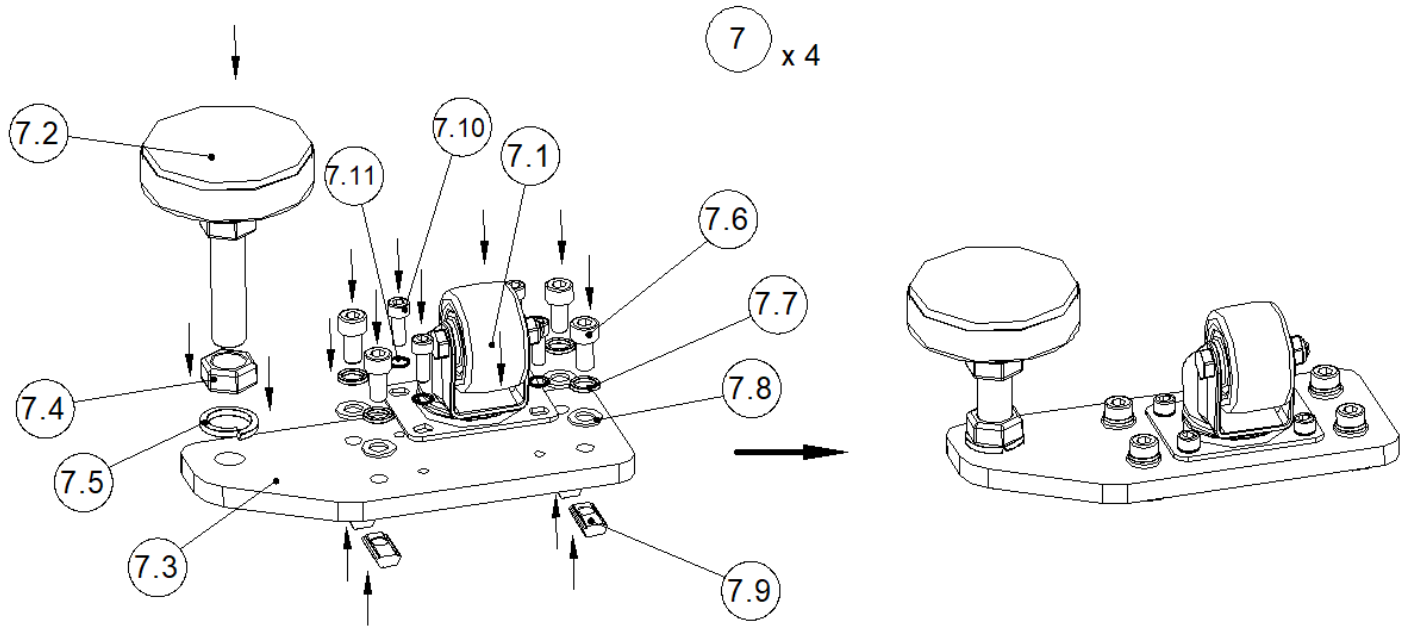

7.1 x1

Bánh xe low gravity
Low gravity wheels

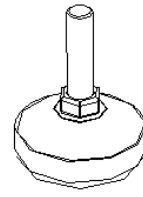

7.2 x1

Chân cao su tĩnh D80 - M16
Rubber feet D80 - M16

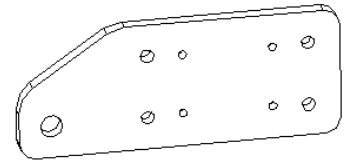

7.3 x1

Gá chân đế Motion
Bracket for feet Motion



7.4 x1

Ecu M16
Check nut M16



7.5 x1

Đệm vênh M16
Spring washer M16



7.6 x4

Inox LGC đầu trụ M8x20
Hexagon socket bolt M8x20



7.7 x4

Đệm vênh M8
Spring washer M8



7.8 x4

Đệm phẳng M8
Flat washer M8



7.9 x4

Con trượt lấy M8
Nuts of profile M8



7.10 x4

Inox LGC đầu trụ M6x16
Hexagon socket bolt M6x16



7.11 x4

Đệm vênh M6
Spring washer M6



VNM SIMULATION .,JSC



VNM SIMULATION ,JSC

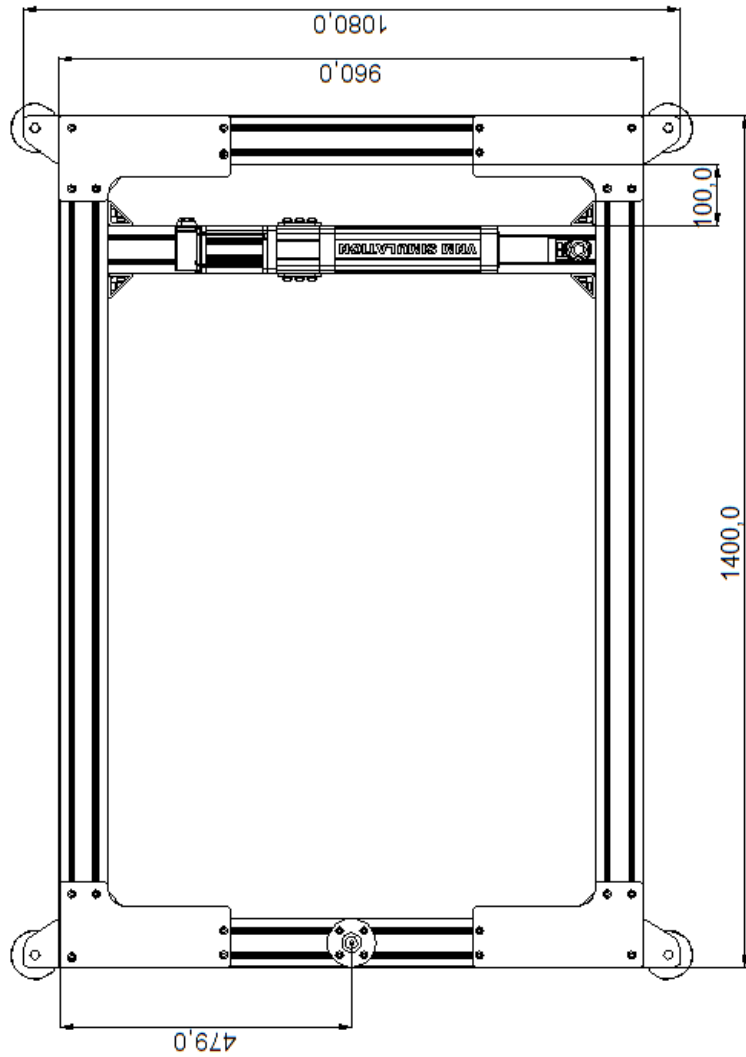
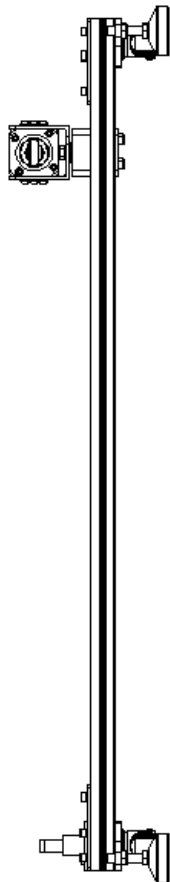
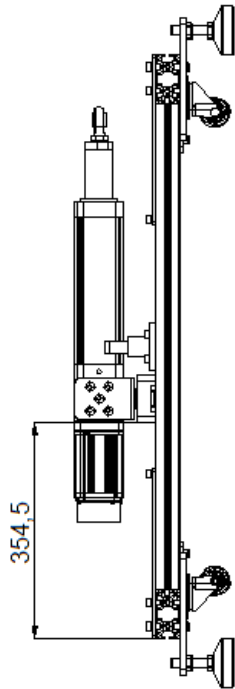



7. 1 Surge và 2 Traction loss platform

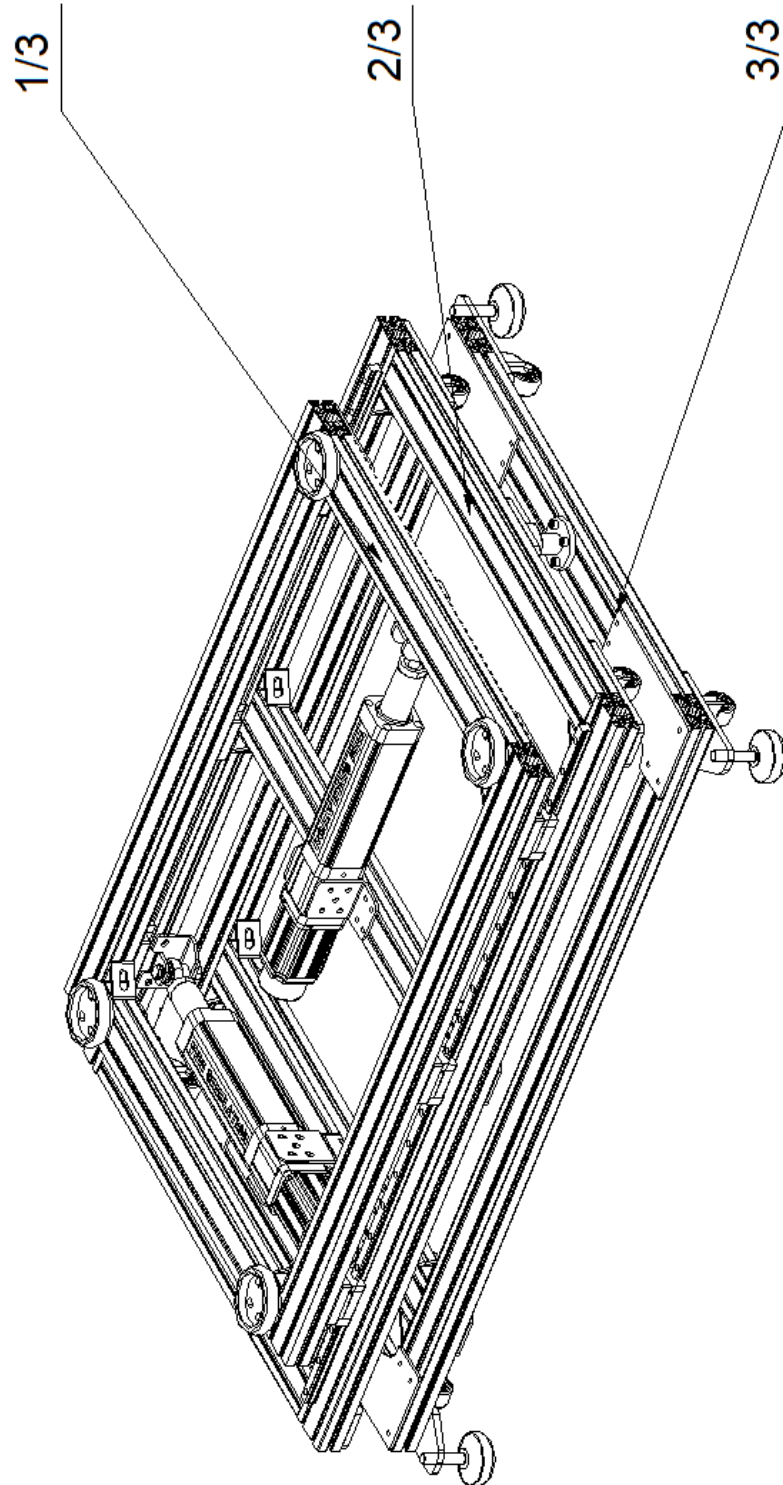



VNM SIMULATION .,JSC



I.