

Neural Machine Translation

Shusen Wang

Sequence-to-Sequence Model (Seq2Seq)

English

German

"do you agree" => [Seq2Seq] => "bist du einverstanden"

"go to sleep" => [Seq2Seq] => "gehen Sie schlafen"

"We will fight" => [Seq2Seq] => "Wir werden kämpfen"

Machine Translation Data

Datasets

- Tab-delimited Bilingual Sentence Pairs: <http://www.manythings.org/anki/>

www.manythings.org/anki/

Things.org Reading Sentences More

- Danish - English [dan-eng.zip](#) (14839)
- Dutch - English [nld-eng.zip](#) (28224)
- Estonian - English [est-eng.zip](#) (1550)
- Finnish - English [fin-eng.zip](#) (49208)
- French - English [fra-eng.zip](#) (155507)
- Galician - English [glg-eng.zip](#) (126)
- Georgian - English [kat-eng.zip](#) (125)
- **German - English [deu-eng.zip](#) (170297)**
- Greek - English [ell-eng.zip](#) (14485)
- Hebrew - English [heb-eng.zip](#) (126137)
- Hindi - English [hin-eng.zip](#) (2867)
- Hungarian - English [hun-eng.zip](#) (54197)
- Icelandic - English [isl-eng.zip](#) (6664)
- Indonesian - English [ind-eng.zip](#) (6702)
- Italian - English [ita-eng.zip](#) (297241)

deu.txt

I survived.	Ich habe überlebt.
I survived.	Ich überlebte.
I think so.	Ich stimme dem zu.
I threw up.	Ich habe gekotzt.
I threw up.	Ich habe mich übergeben.
I threw up.	Ich habe erbrochen.
I use this.	Ich verwende das.
I use this.	Ich benutze das.
I want Tom.	Ich will Tom.
I want one!	Ich will einen!
I want one!	Ich will eins!
I want one!	Ich will eine!
I want one.	Ich will eins.
I want you.	Ich will dich.
I want you.	Ich will dich!
I was busy.	Ich war beschäftigt.
I was good.	Ich war gut.
I was rude.	Ich war ruppig.
I was sick.	Ich war krank.

Datasets

- **Preprocessing:** to lower case, remove punctuation, etc.

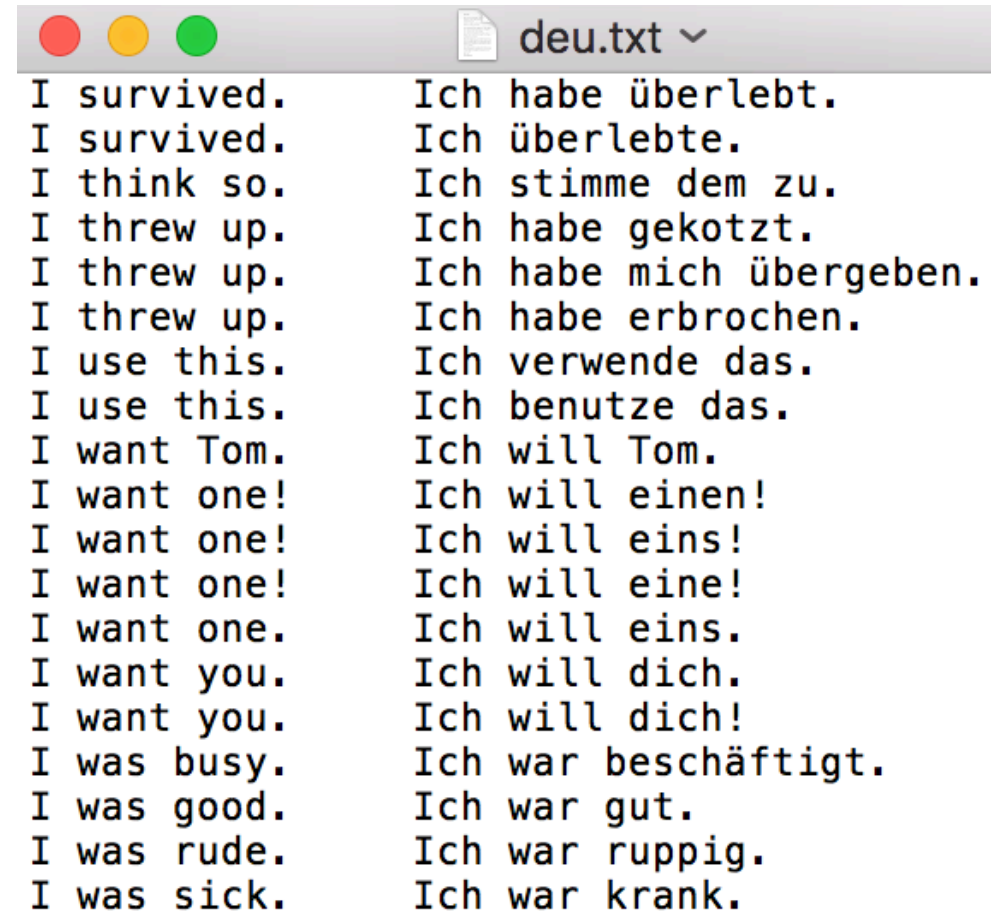

A screenshot of a text editor window titled "deu.txt". The window contains two columns of text. The left column contains English sentences, and the right column contains their German translations. The sentences are as follows:

I survived.	Ich habe überlebt.
I survived.	Ich überlebte.
I think so.	Ich stimme dem zu.
I threw up.	Ich habe gekotzt.
I threw up.	Ich habe mich übergeben.
I threw up.	Ich habe erbrochen.
I use this.	Ich verwende das.
I use this.	Ich benutze das.
I want Tom.	Ich will Tom.
I want one!	Ich will einen!
I want one!	Ich will eins!
I want one!	Ich will eine!
I want one.	Ich will eins.
I want you.	Ich will dich.
I want you.	Ich will dich!
I was busy.	Ich war beschäftigt.
I was good.	Ich war gut.
I was rude.	Ich war ruppig.
I was sick.	Ich war krank.

1. Tokenization & Build Dictionary

- `input_texts` => [**Eng_Tokenizer**] => `input_tokens`
- `target_texts` => [**Deu_Tokenizer**] => `target_tokens`



- Use 2 different tokenizers for the 2 languages.
- Then build 2 different dictionaries.

1. Tokenization & Build Dictionary

- `input_texts` => [**Eng_Tokenizer**] => `input_tokens`
- `target_texts` => [**Deu_Tokenizer**] => `target_tokens`

Tokenization in the **char-level**.

Tokenization in the **word-level**.

1. Tokenization & Build Dictionary

- `input_texts` => [**Eng_Tokenizer**] => `input_tokens`
- `target_texts` => [**Deu_Tokenizer**] => `target_tokens`

Tokenization in the **char-level**.

Eng_Tokenizer

- `"I_am_okay."` => `['i', '_', 'a', 'm', ..., 'a', 'y']`

Deu_Tokenizer

- `"Es geht mir gut"` => `['e', 's', '_', ..., 'u', 't']`

1. Tokenization & Build Dictionary

Question: Why 2 different tokenizers and dictionaries?

Answer: In the **char-level**, languages have different **alphabets/chars**.

- English: A a, B b, C c ..., Z z. (26 letters ×2).
- German: 26 letters, 3 umlauts (Ä, Ö, Ü), and one ligature (ß).
- Greek: A α, B β, Γ γ, Δ δ, ..., Ω ω. (24 letters ×2).
- Chinese: 金 木 水 火 土 ... 赵 钱 孙 李 (a few thousands characters).
- Japanese: あ い う え お ... (46 Hiragana, 46 Karagana, hundreds 漢字).

1. Tokenization & Build Dictionary

Question: Why 2 different tokenizers and dictionaries?

Answer: In the **word-level**, languages have different **vocabulary**.

- English:

Machine learning is a generic term for the artificial generation of knowledge from experience: An artificial system learns from examples and can generalize these after completion of the learning phase.

- Deutsche:



Maschinelles Lernen ist ein Oberbegriff für die künstliche Generierung von Wissen aus Erfahrung: Ein künstliches System lernt aus Beispielen und kann diese nach Beendigung der Lernphase verallgemeinern.

1. Tokenization & Build Dictionary

Eng_Dictionary

- 'a' => 1
- 'b' => 2
- 'c' => 3
- 'd' => 4
- ..
- 'z' => 26
- '_' => 27

Deu_Dictionary

- '\t' => 1  start sign
- '\n' => 2  stop sign
- 'a' => 3
- 'b' => 4
- 'c' => 5
- 'd' => 6
- ..
- 'z' => 28
- '_' => 29

2. One-Hot Encoding

"I_am_okay."

Eng_Tokenizer

['i', '_', 'a', 'm', '_', 'o', 'k', 'a', 'y']

Encoding using Eng_Dictionary

[9, 27, 1, 13, 27, 15, 11, 1, 25]

2. One-Hot Encoding

"Es geht mir gut"

↓ Deu_Tokenizer

['e', 's', '_', 'g', 'e', ..., 'g', 'u', 't']

↓ Encoding using Deu_Dictionary

[7, 21, 29, 9, 7, ..., 9, 23, 22]

2. One-Hot Encoding

`['i', '_', 'a', 'm', '_', 'o', 'k', 'a', 'y']`

`[9, 27, 1, 13, 27, 15, 11, 1, 25]`

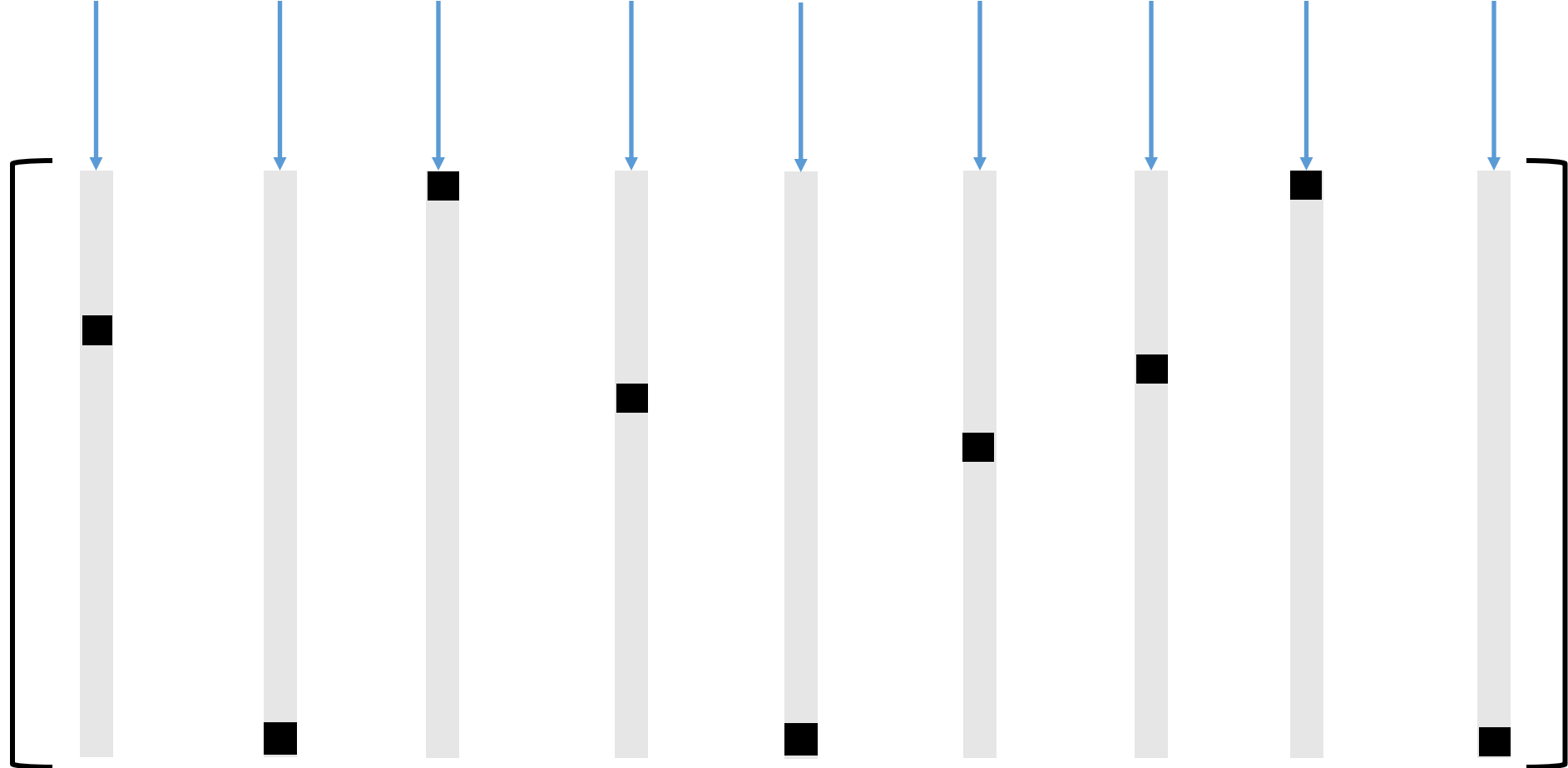

Training Seq2Seq Model

Seq2Seq Model

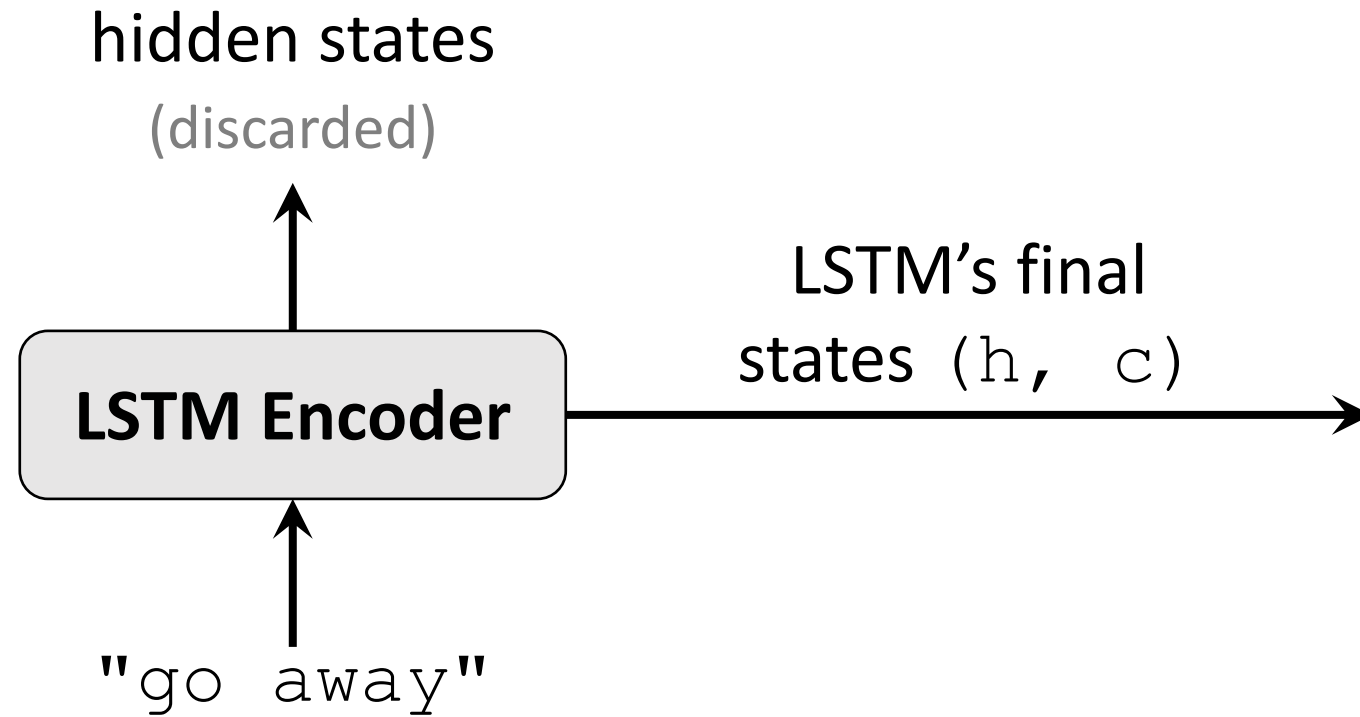

Seq2Seq Model

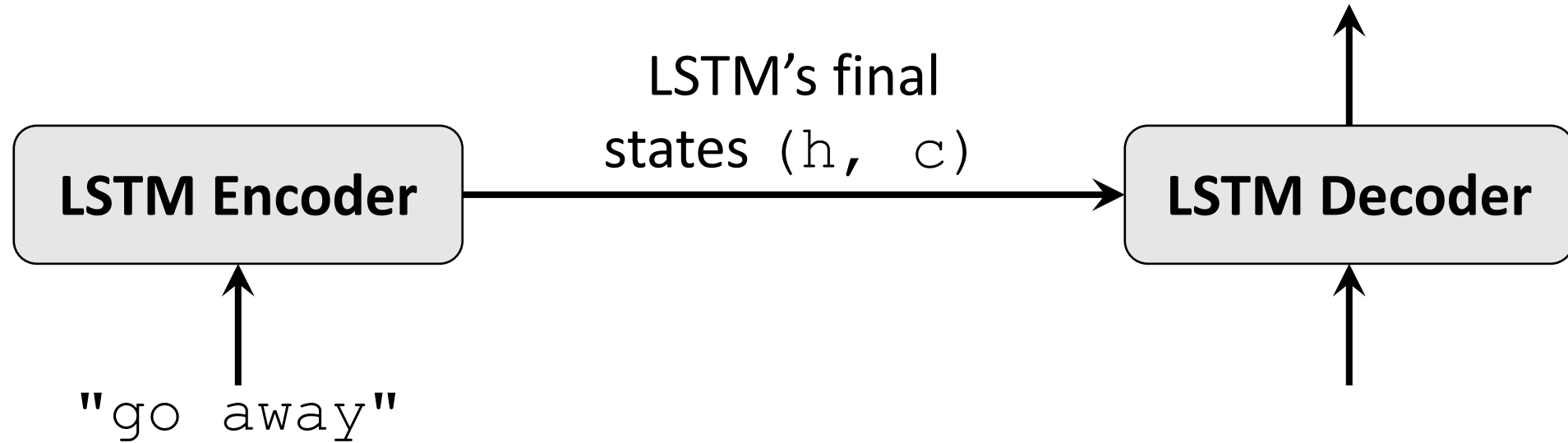

Training Seq2Seq Model

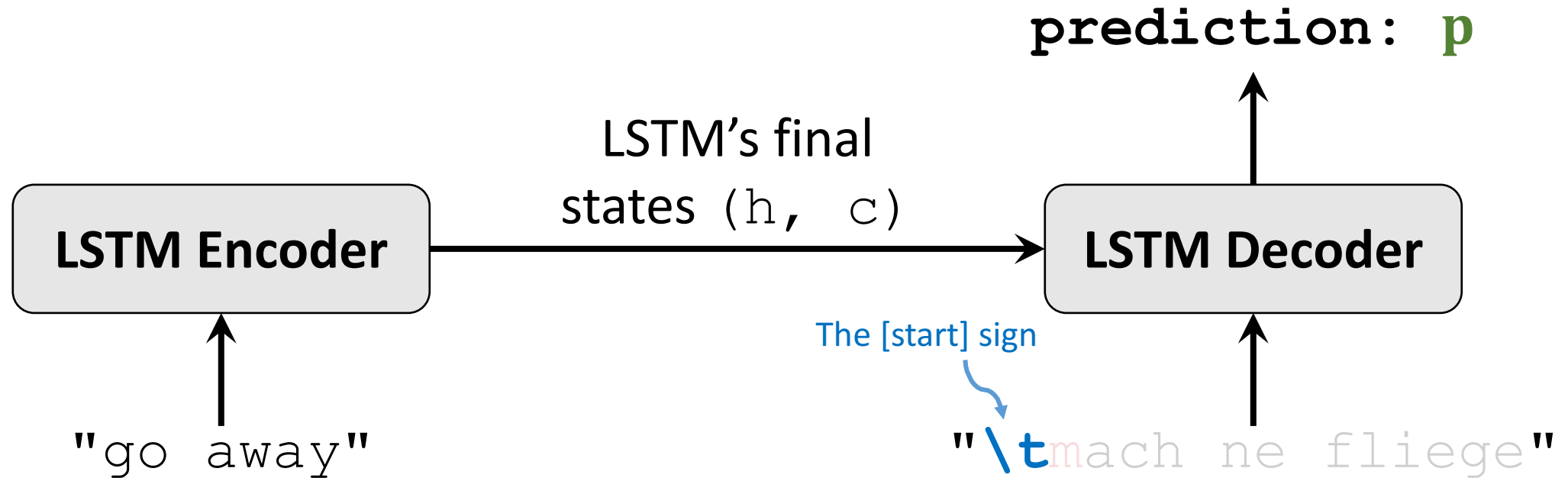

Training Seq2Seq Model

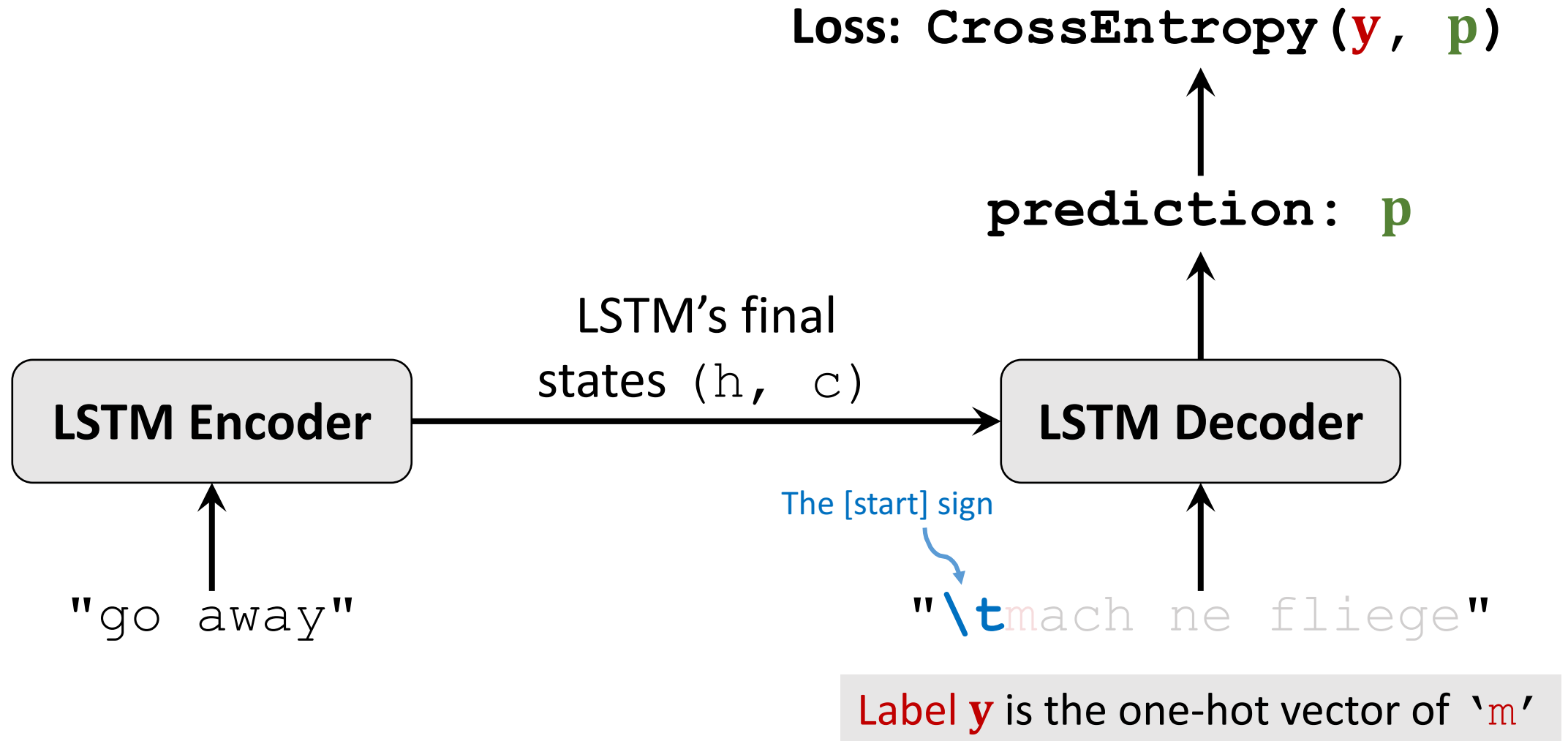

Training Seq2Seq Model

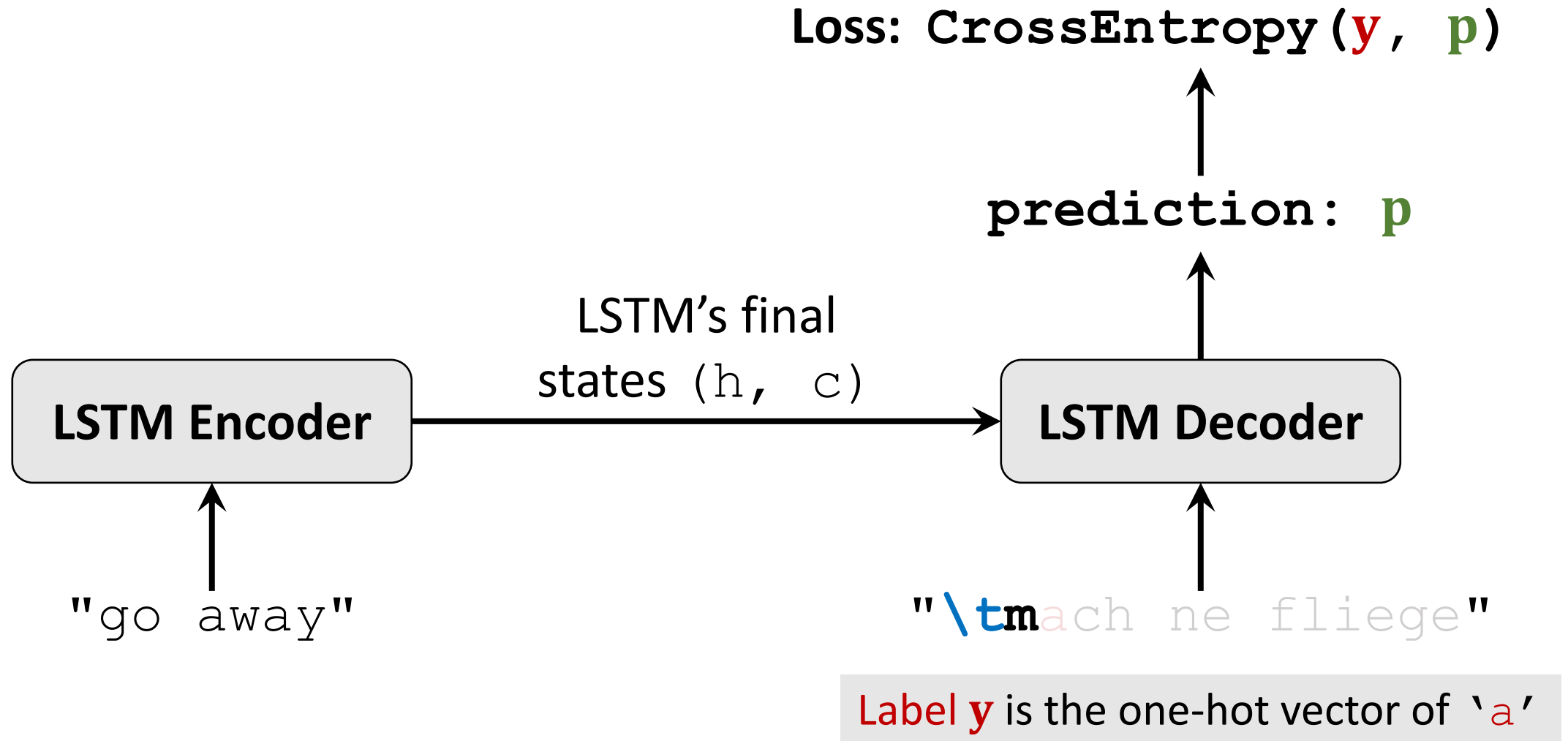

Training Seq2Seq Model

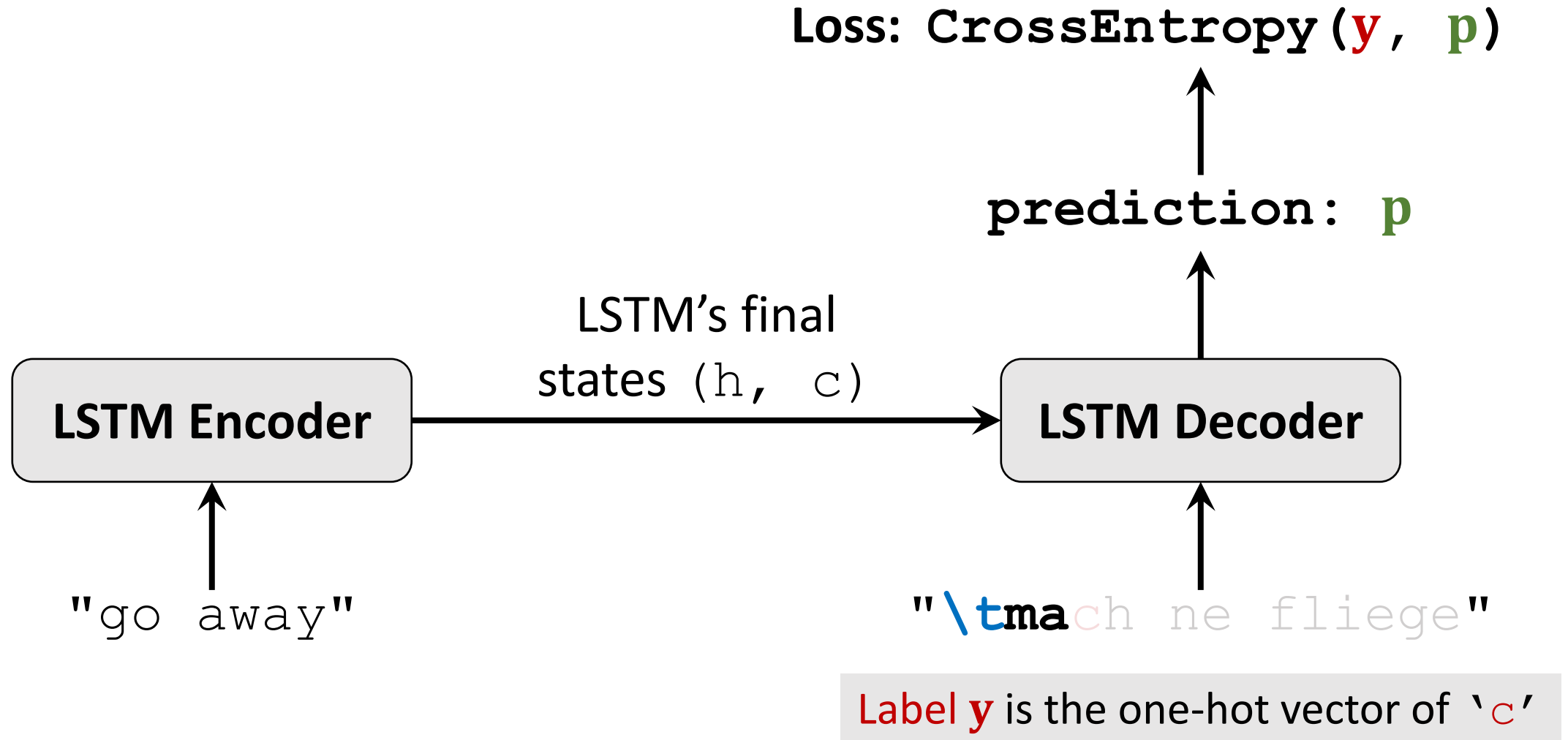

Training Seq2Seq Model



Training Seq2Seq Model

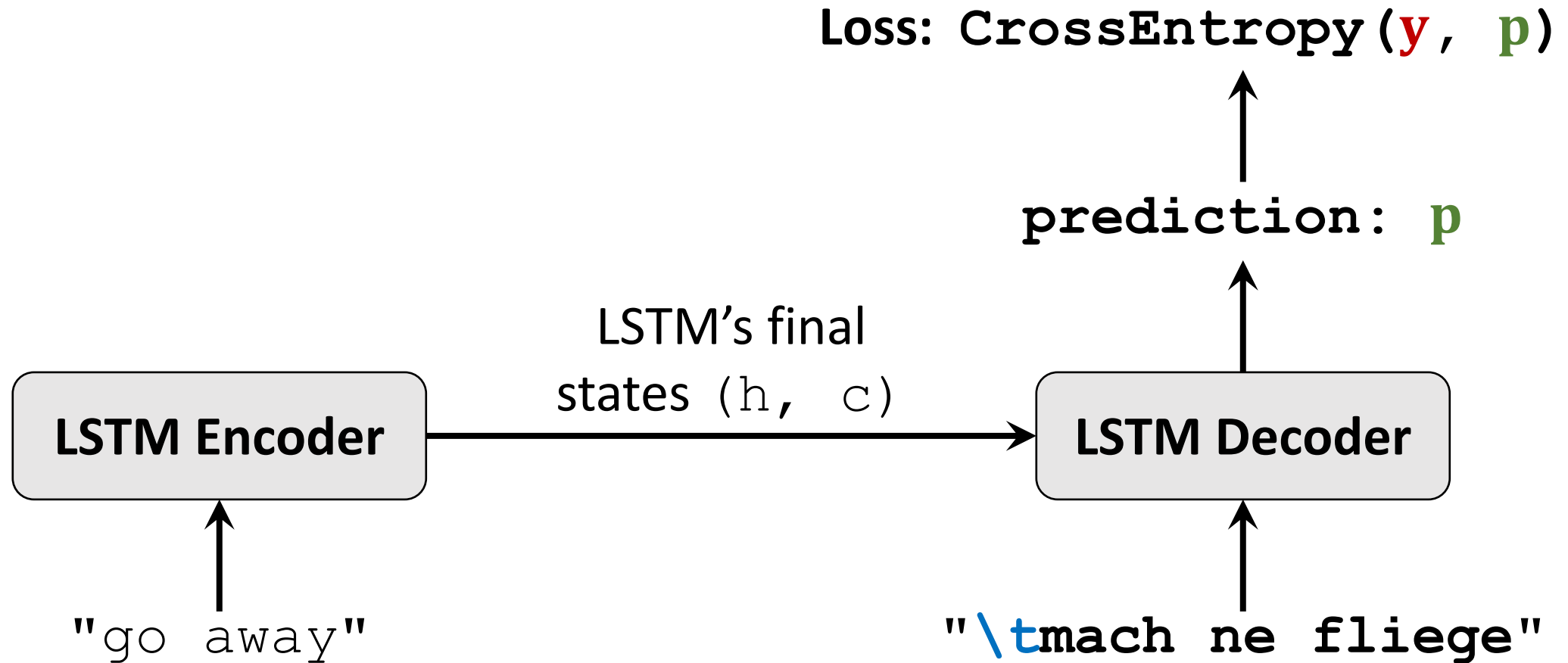

Label y is the one-hot vector of the [stop] sign.

Seq2Seq Model in Keras

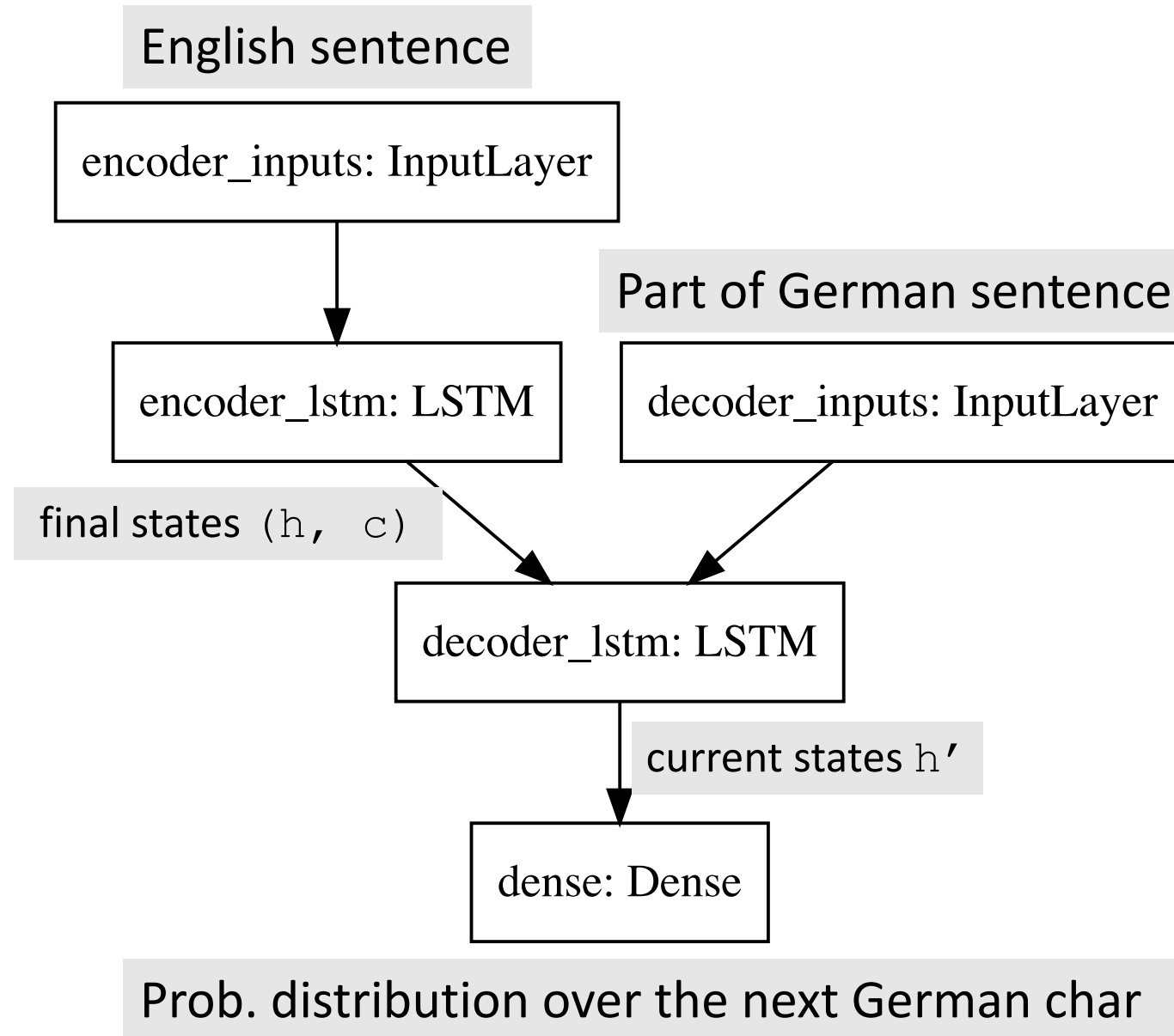

Inference Using the Seq2Seq Model

Inference

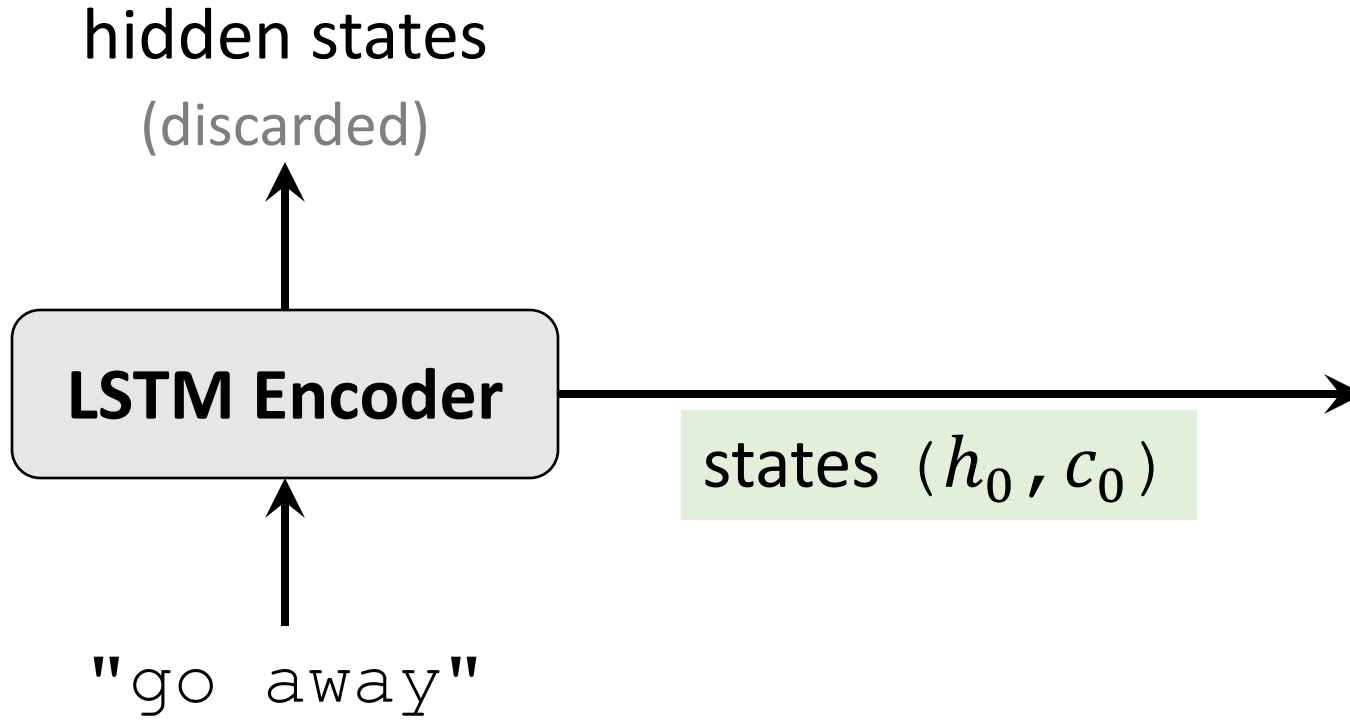

Inference

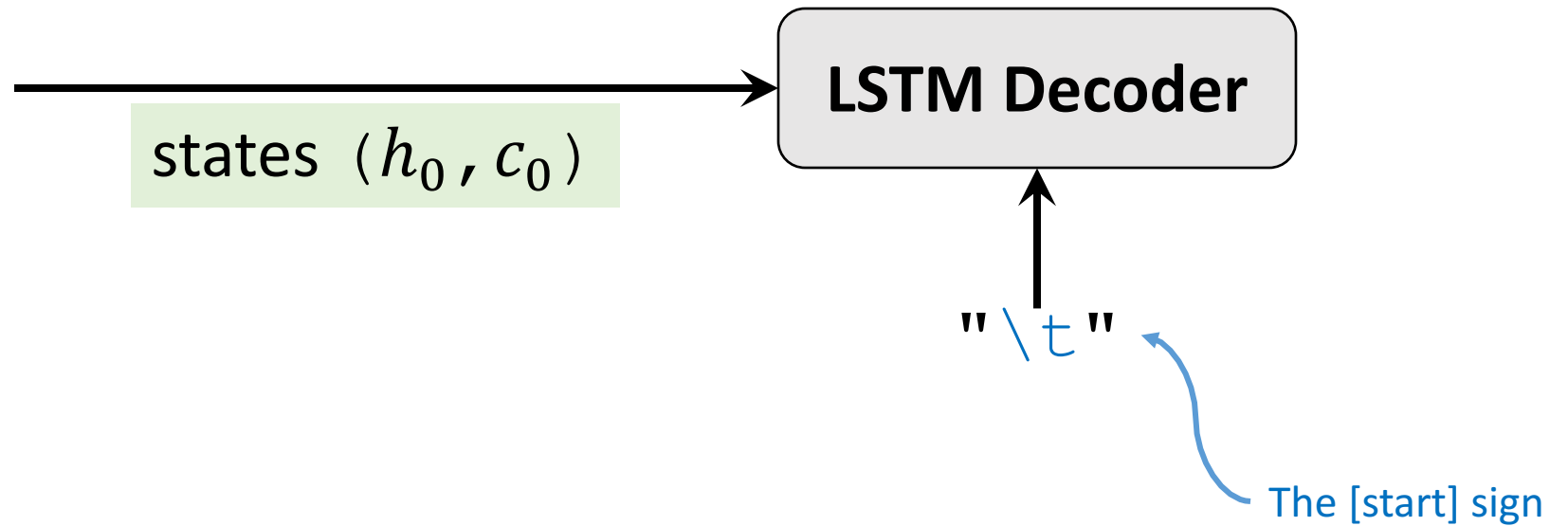

Inference

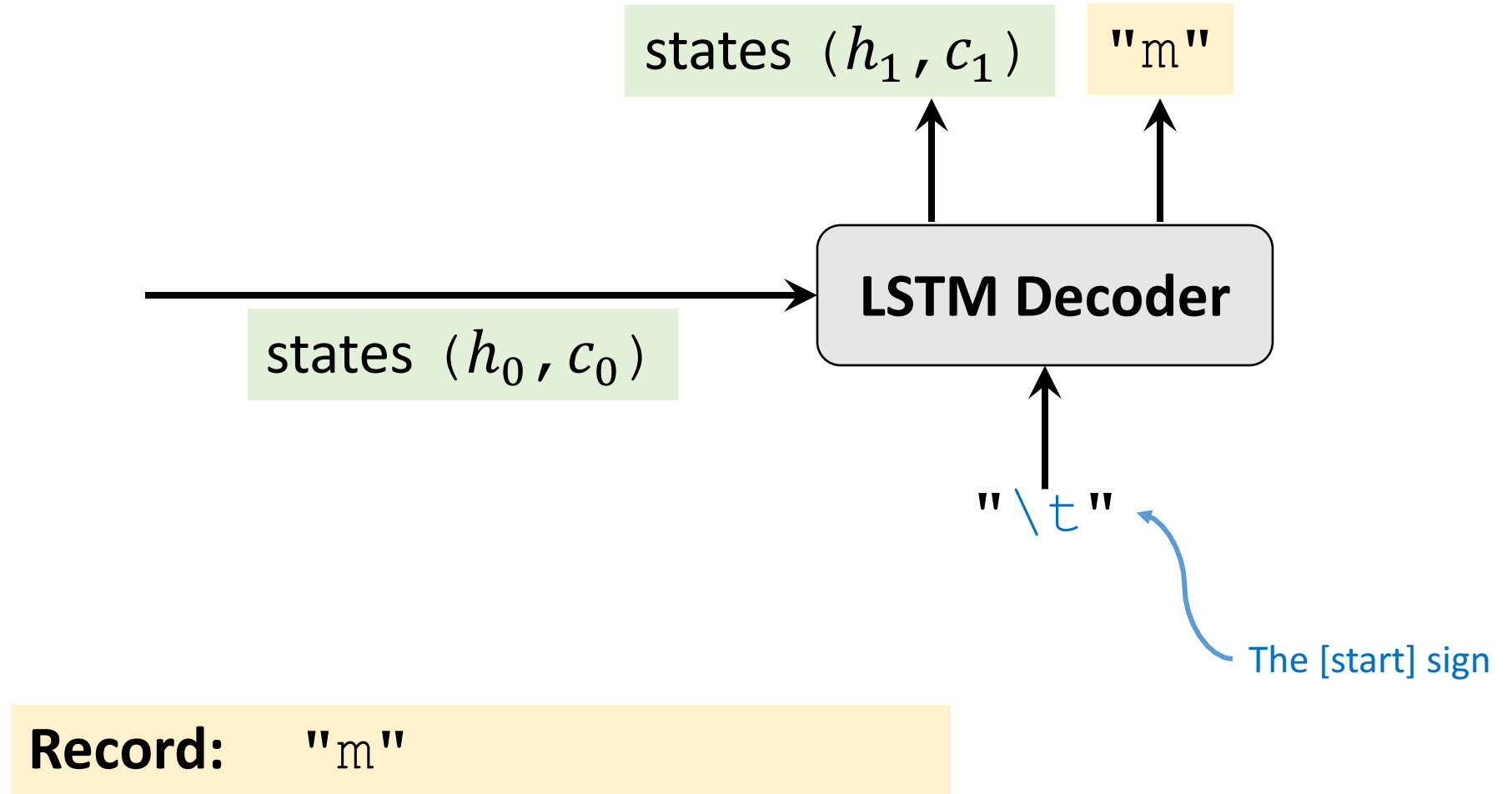

Inference

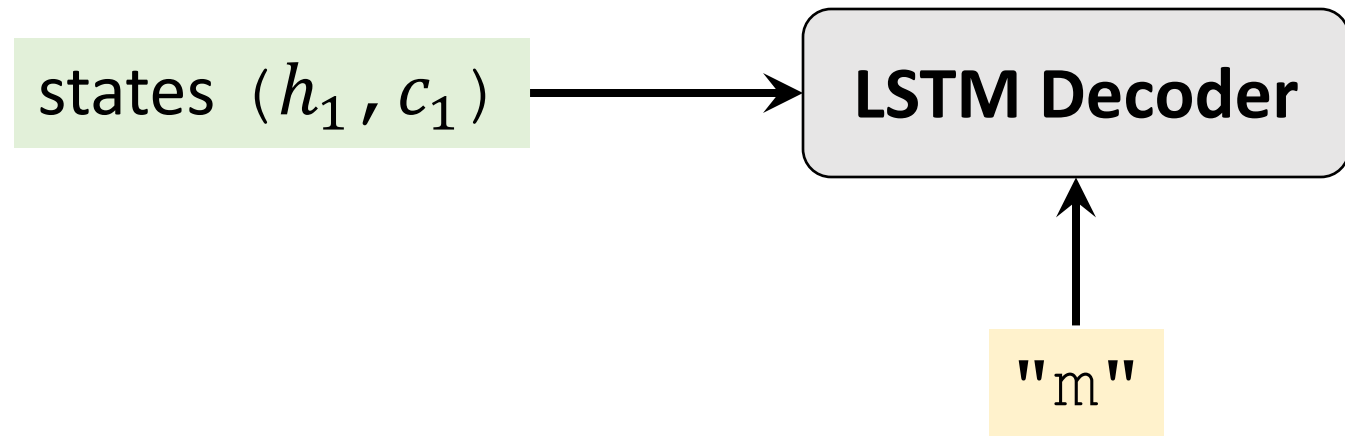

Record: `"m"`

Inference

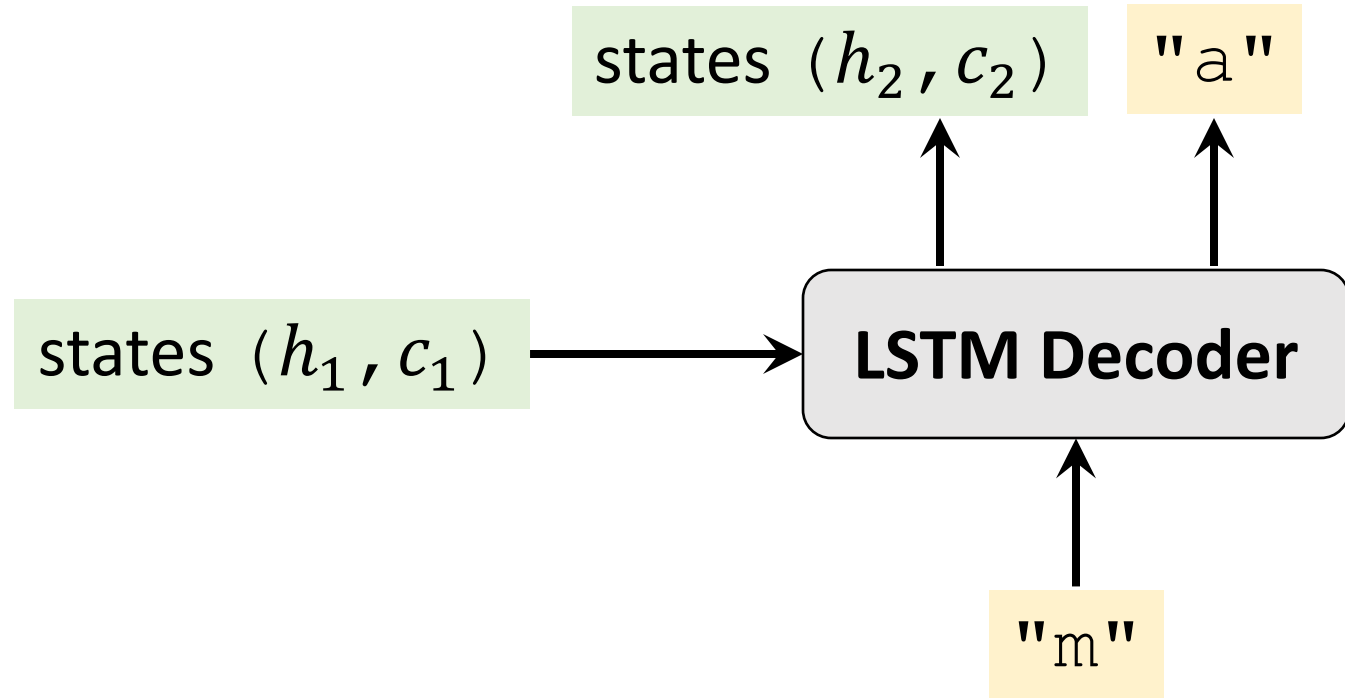

Record: "ma"

Inference

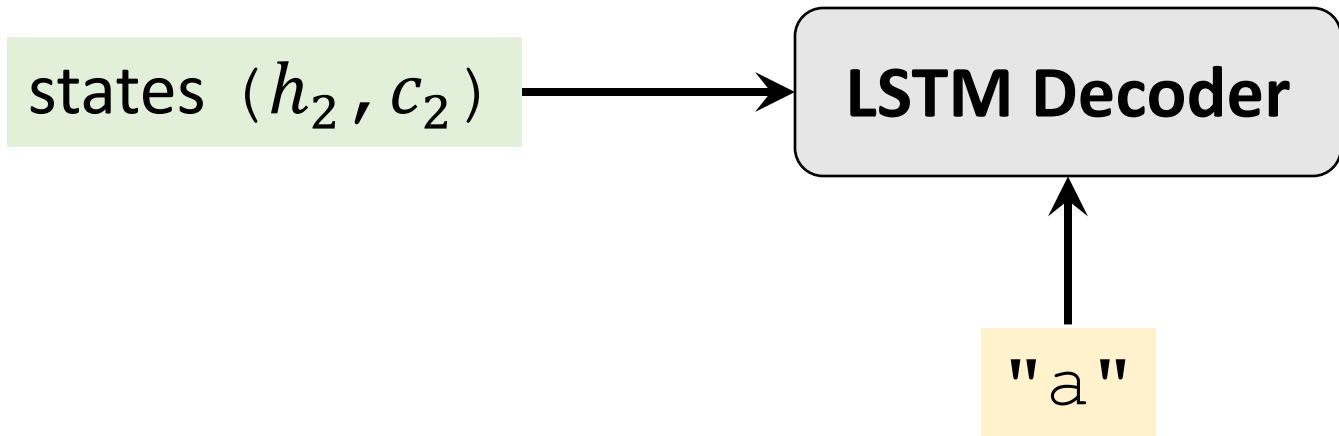

Record: "ma"

Inference

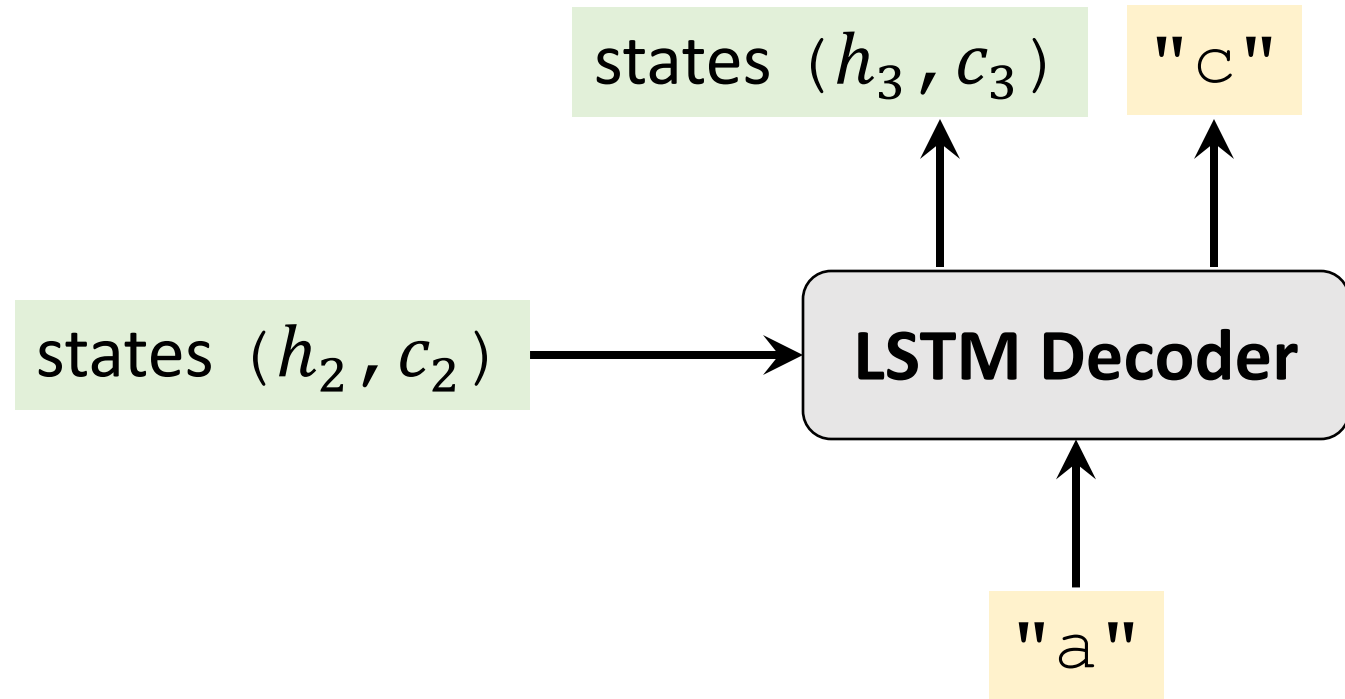

Record: "mac"

Inference

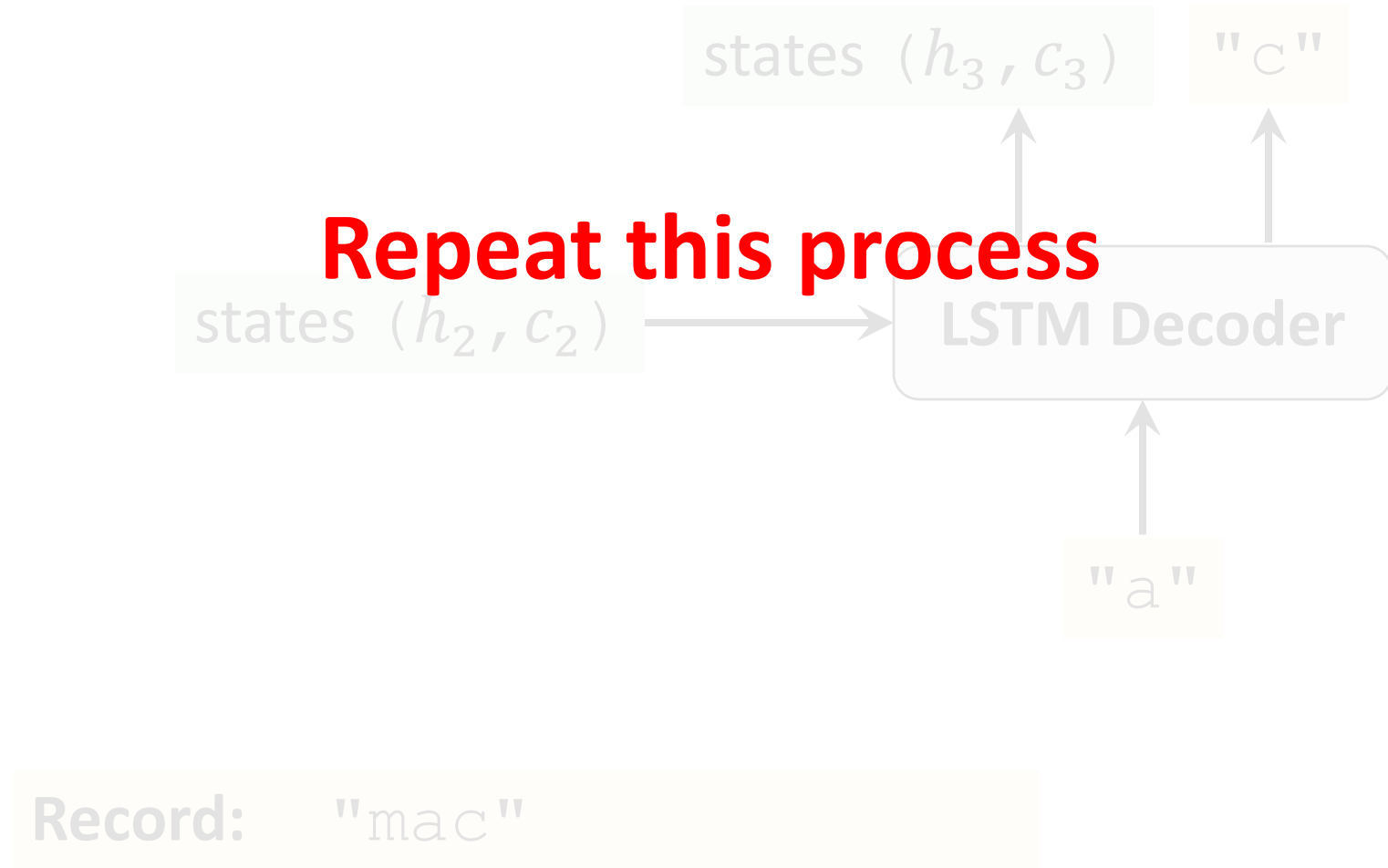

Inference

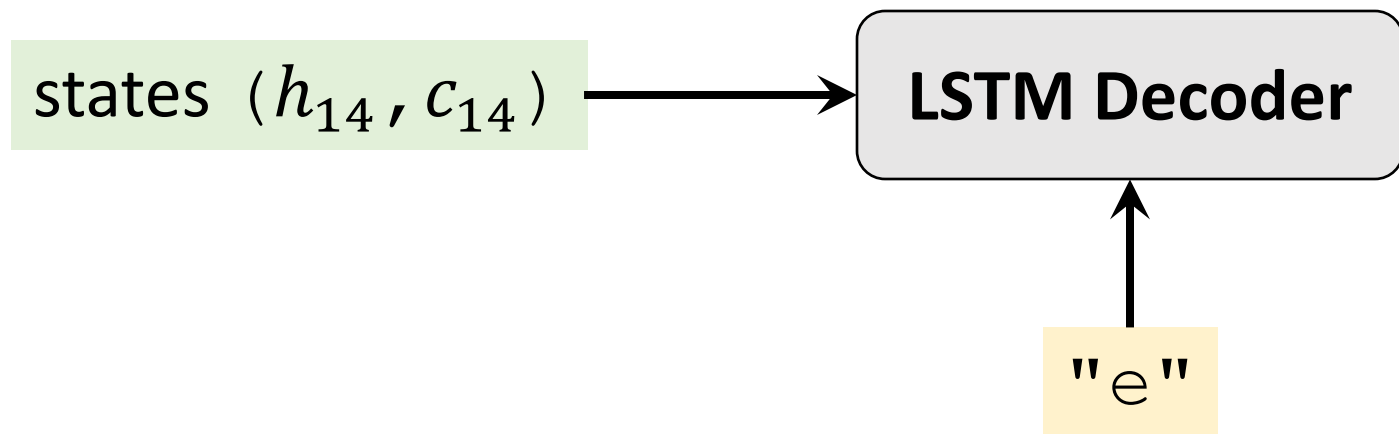

Record: "mach ne fliege"

Inference

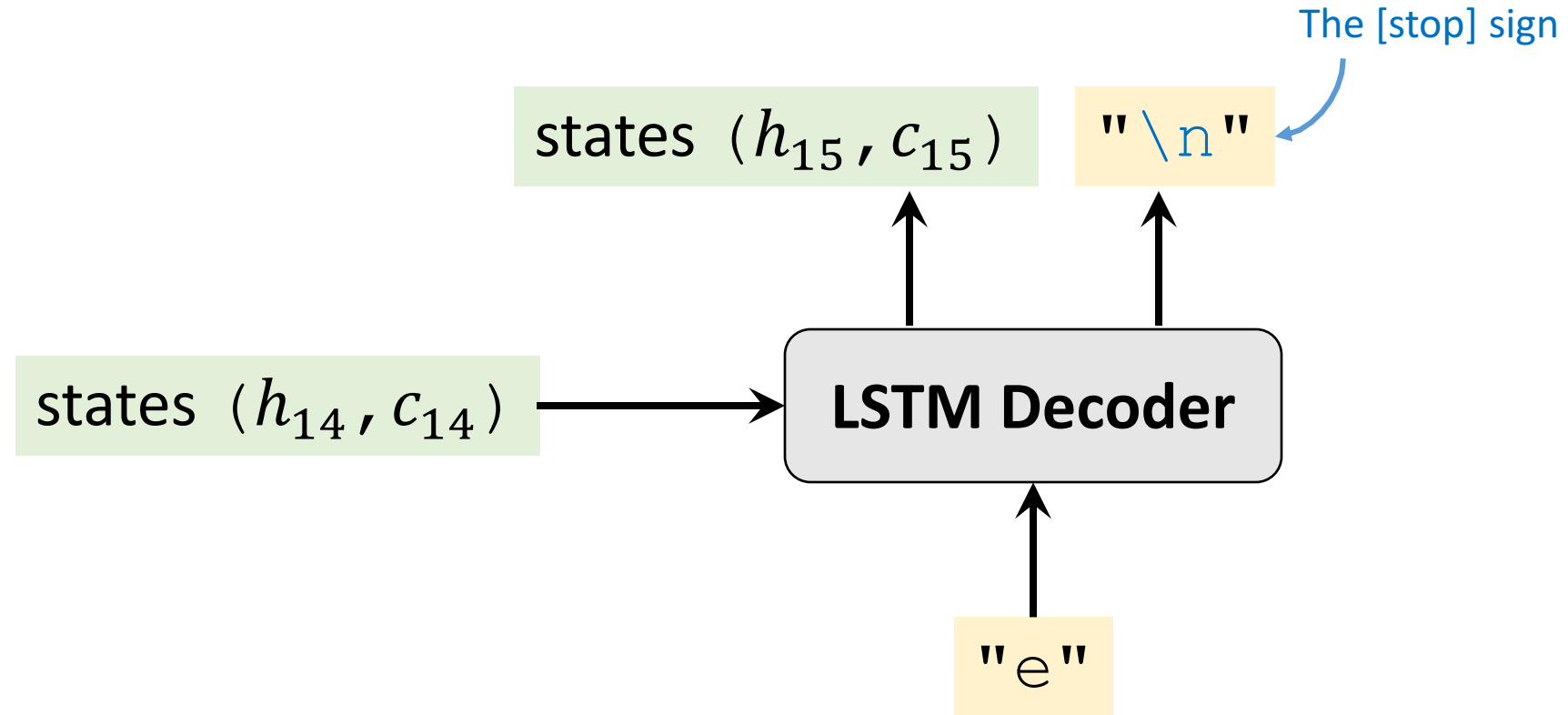

Record: "mach ne fliege"

Inference

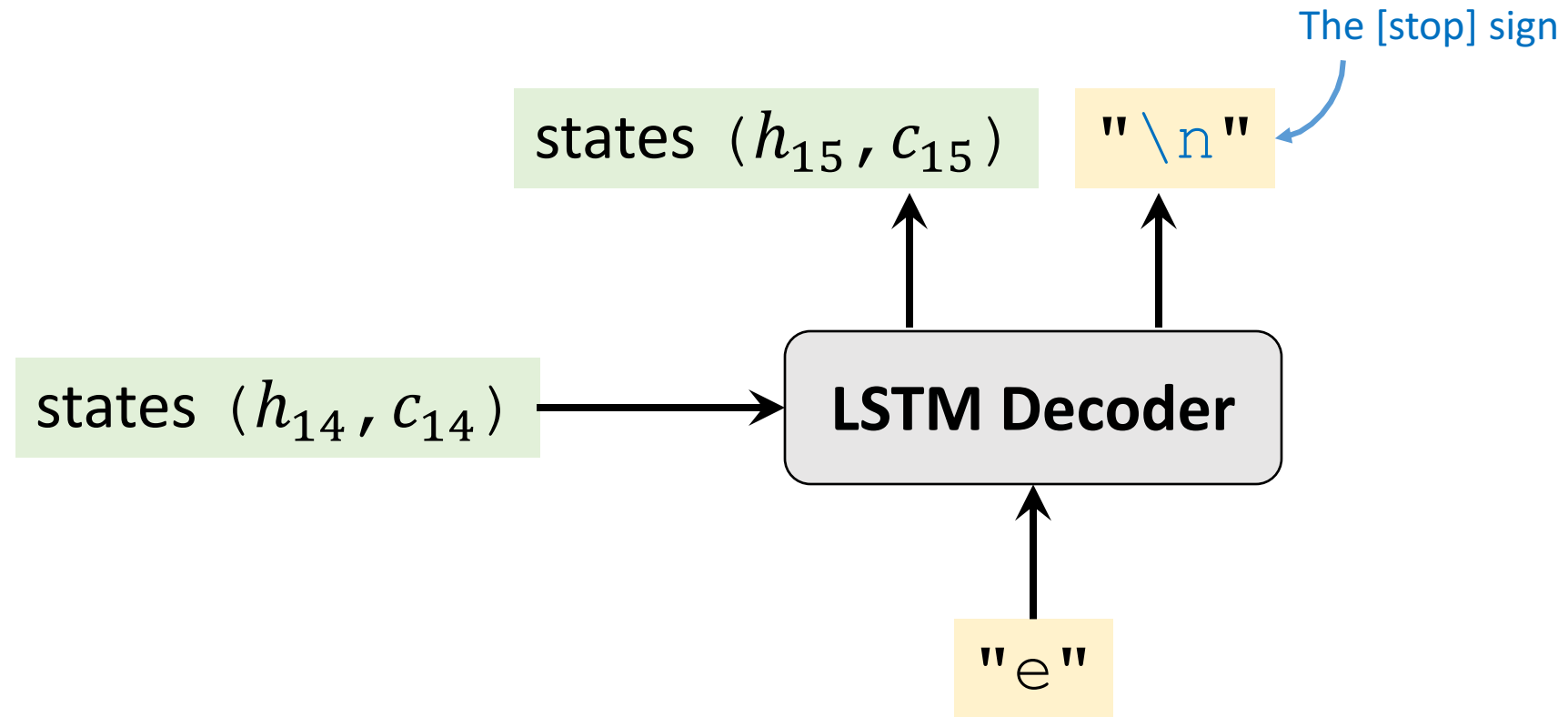

Return: "mach ne fliege"

Summary

Seq2Seq Model

Encoder RNN

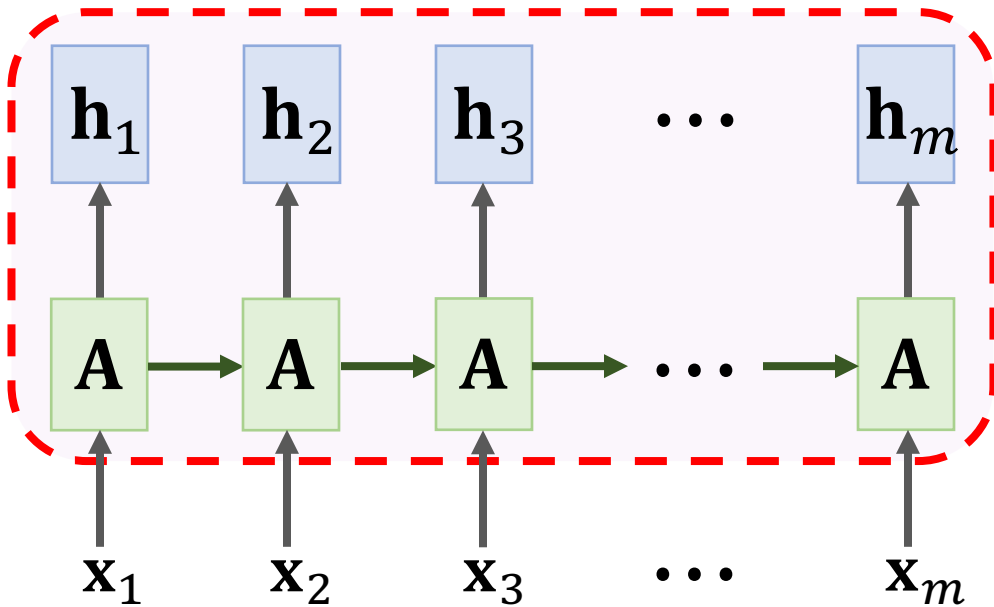

Seq2Seq Model

Encoder RNN

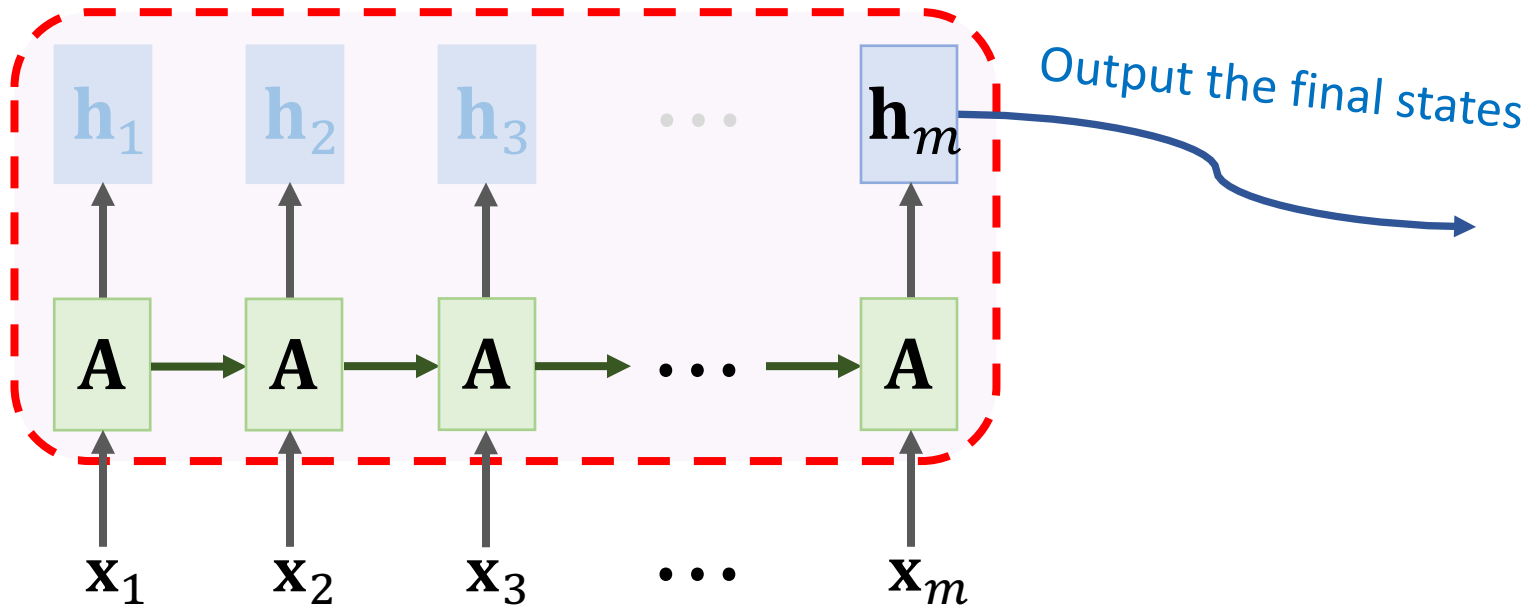

Seq2Seq Model

Encoder RNN

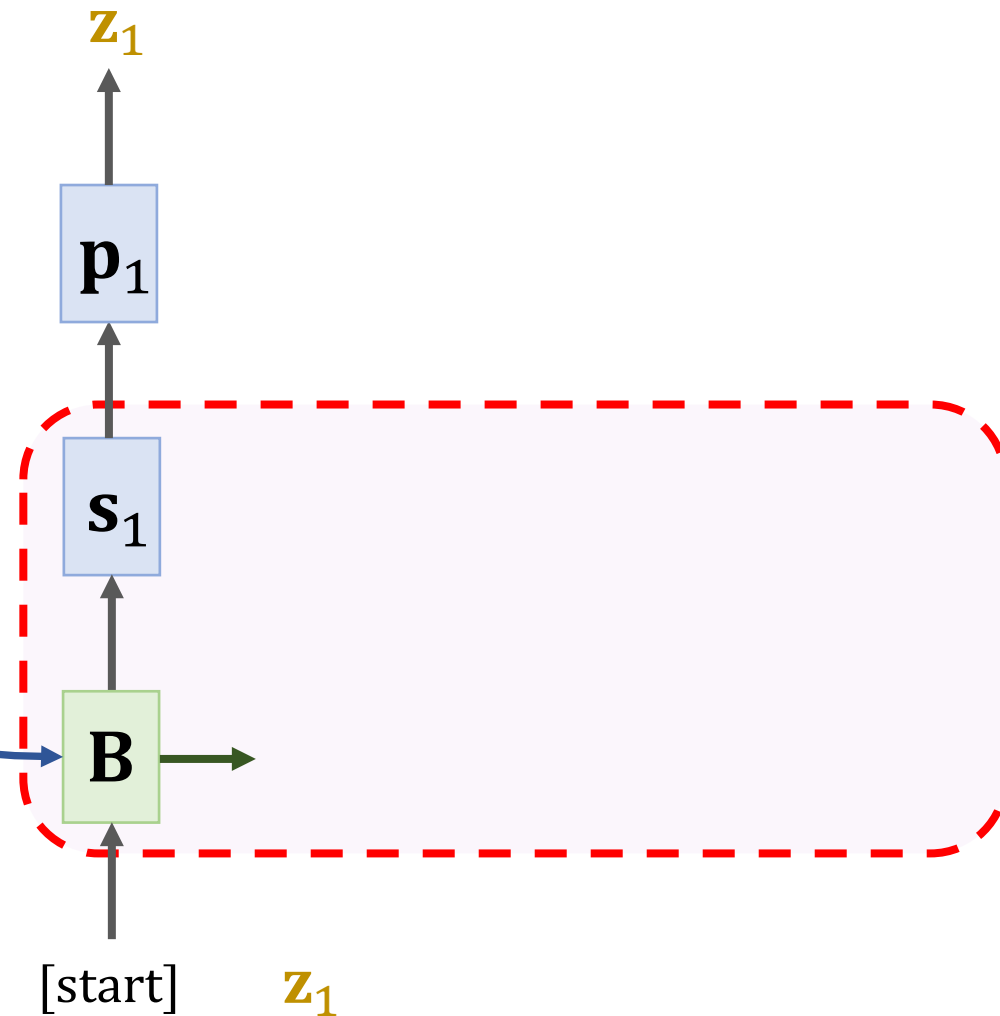
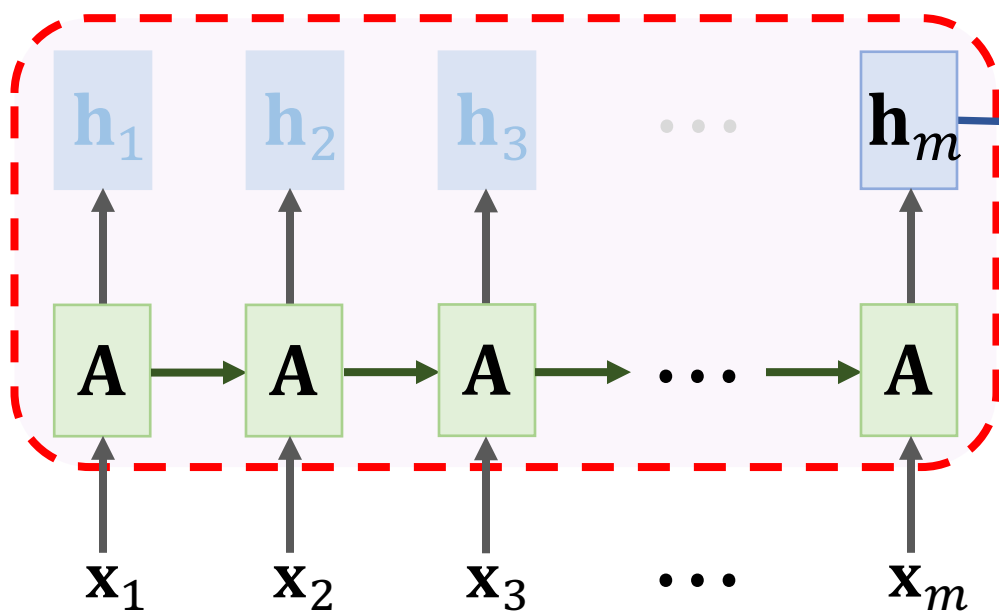

Decoder RNN

Seq2Seq Model

Encoder RNN

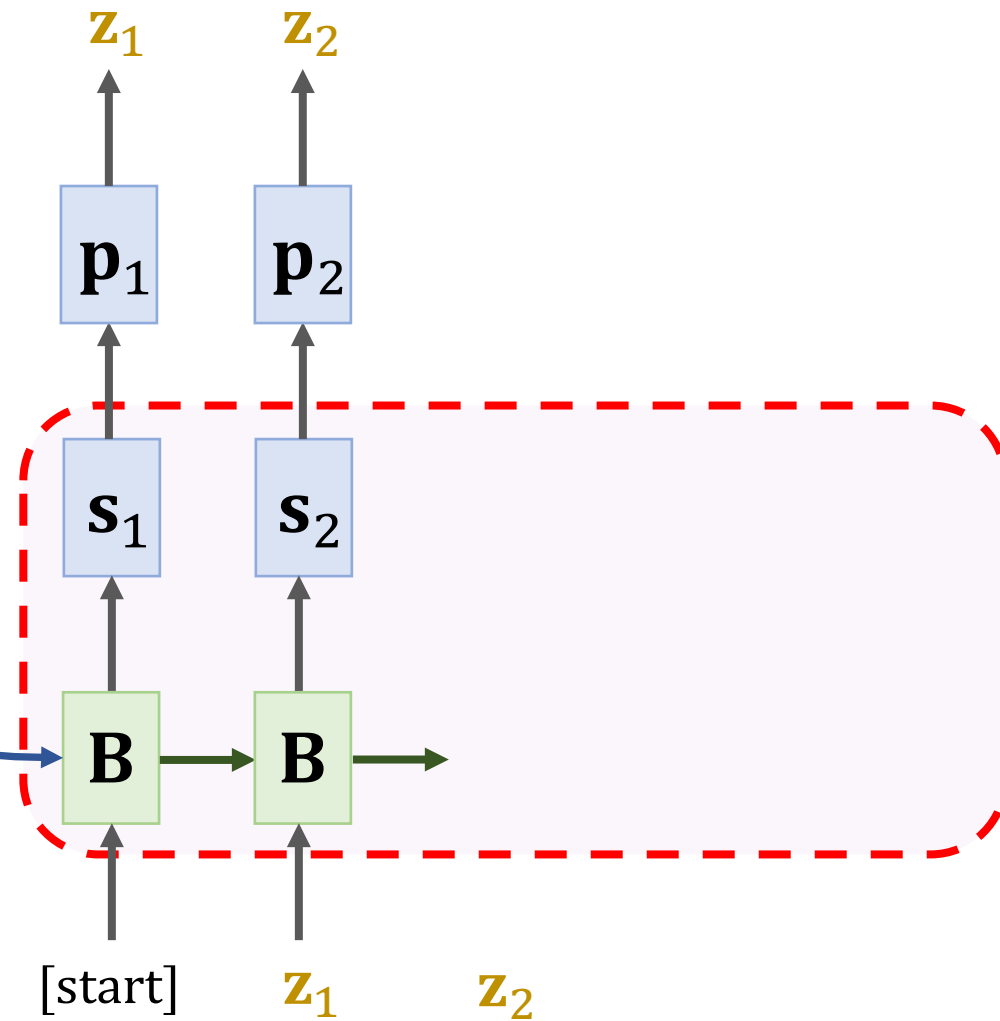
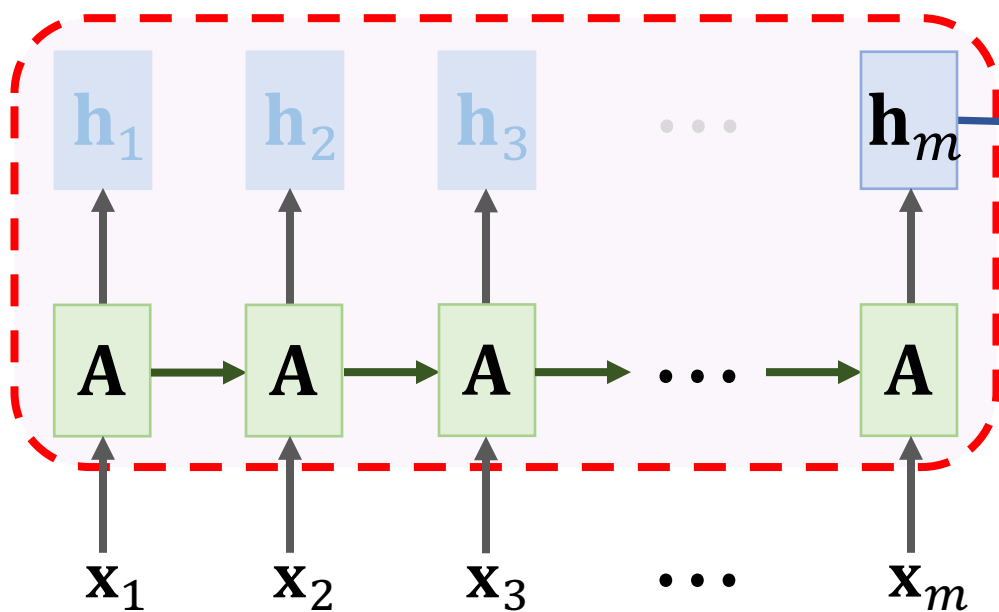

Decoder RNN

Seq2Seq Model

Encoder RNN

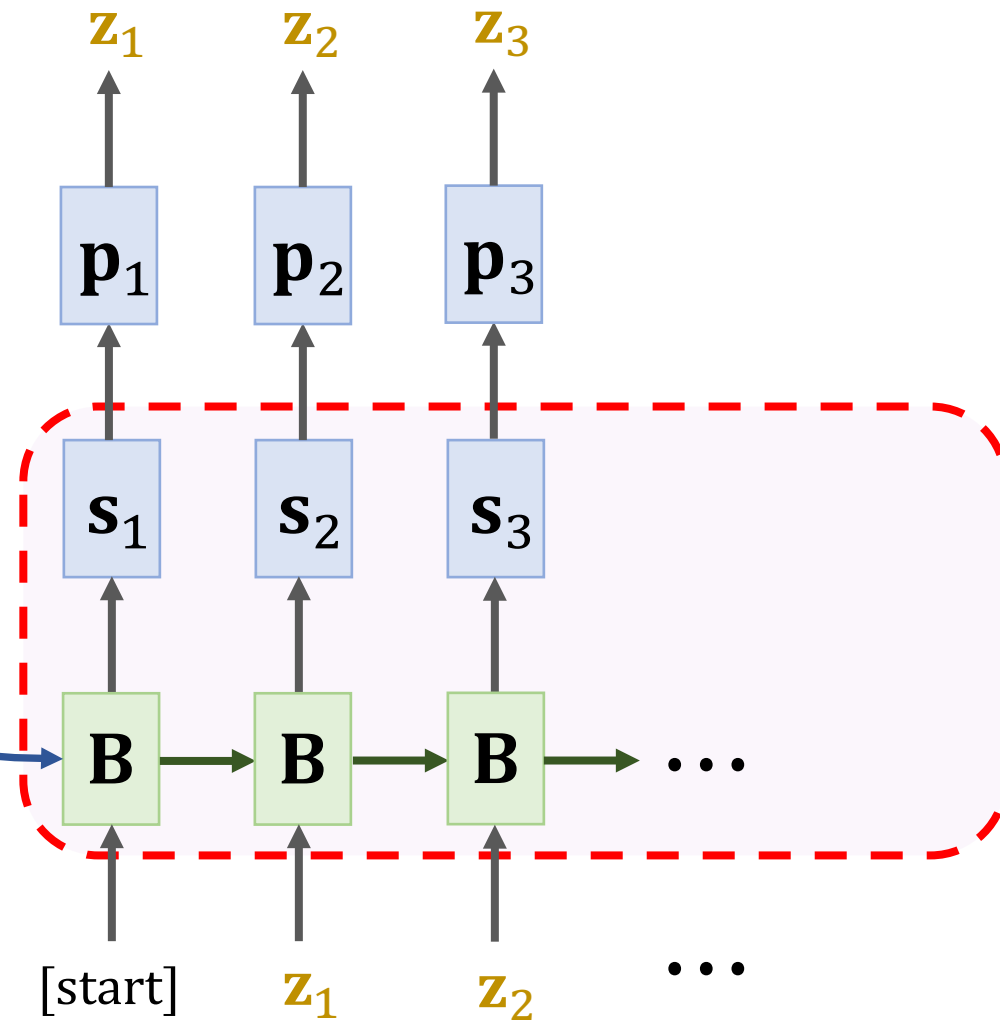
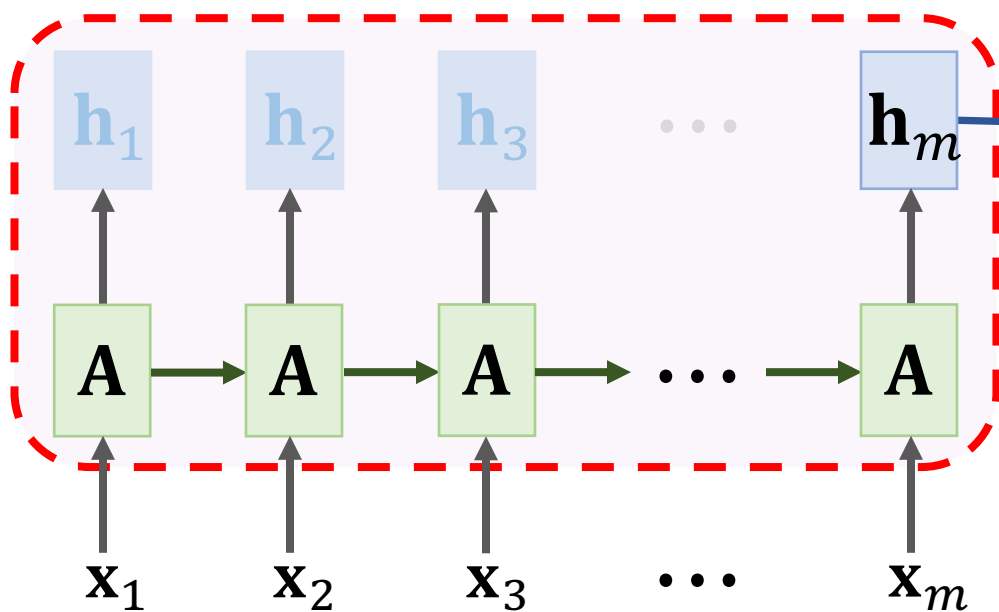

Decoder RNN

Seq2Seq Model

Encoder RNN

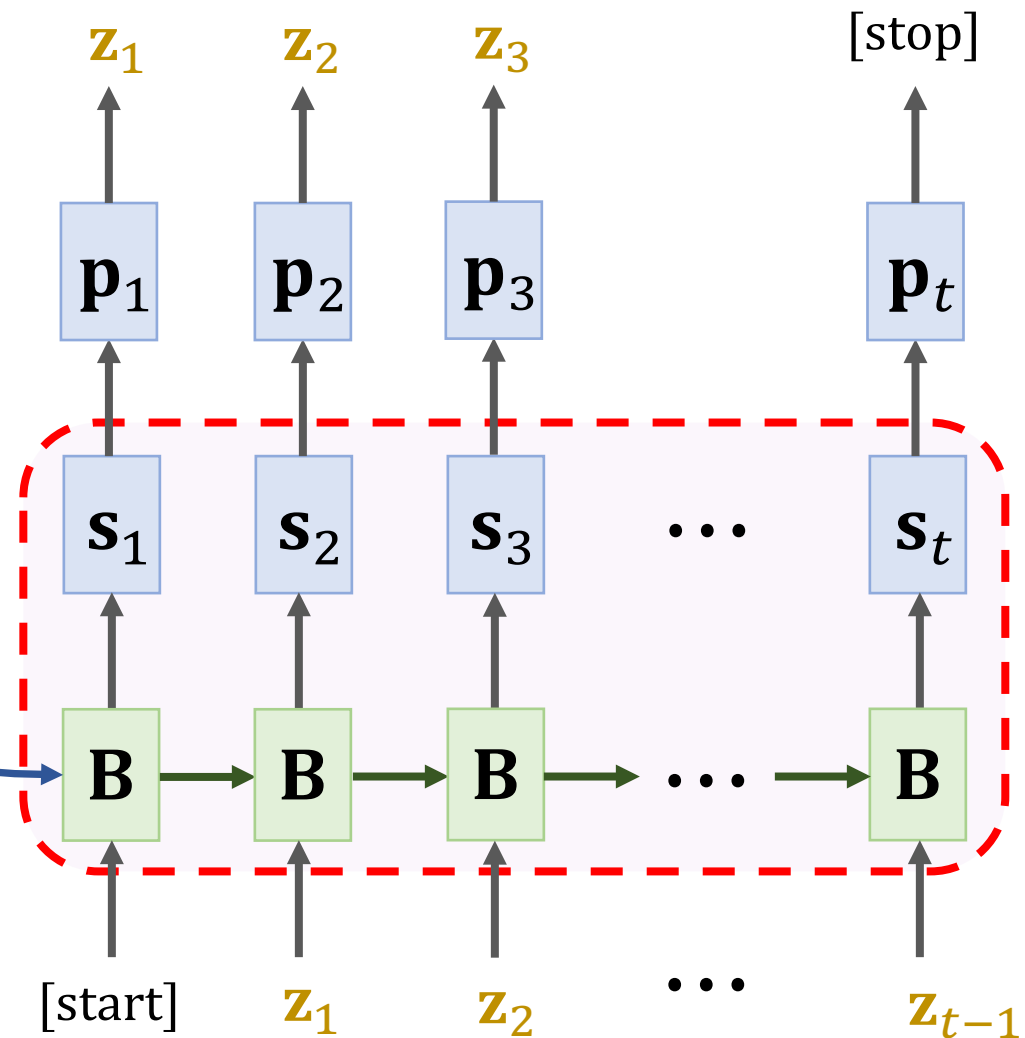
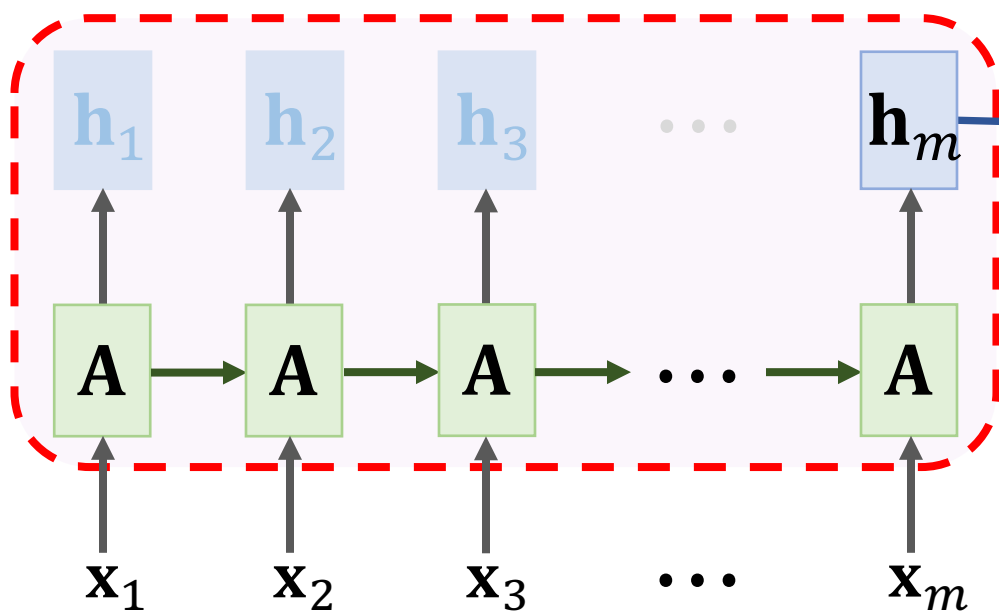

Decoder RNN

How to Improve?

1. Bi-LSTM instead of LSTM (Encoder only!)

- Encoder's final states (\mathbf{h}_t and \mathbf{c}_t) have all the information of the English sentence.
- If the sentence is long, the final states have forgotten early inputs.

1. Bi-LSTM instead of LSTM (Encoder only!)

- Encoder's final states (\mathbf{h}_t and \mathbf{c}_t) have all the information of the English sentence.
- If the sentence is long, the final states have forgotten early inputs.
- Bi-LSTM (left-to-right and right-to-left) has longer memory.

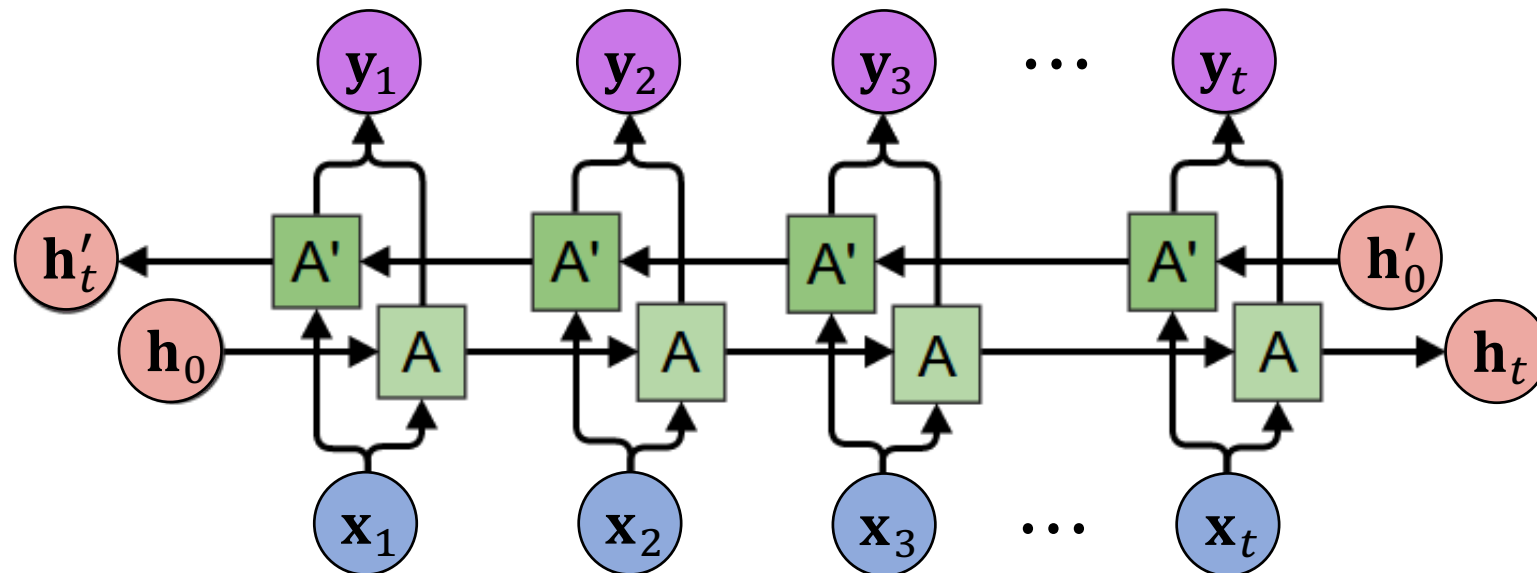

1. Bi-LSTM instead of LSTM (Encoder only!)

- Encoder's final states (\mathbf{h}_t and \mathbf{c}_t) have all the information of the English sentence.
- If the sentence is long, the final states have forgotten early inputs.
- Bi-LSTM (left-to-right and right-to-left) has longer memory.
- Use Bi-LSTM in the encoder; use unidirectional LSTM in the decoder.

2. Word-Level Tokenization

- Word-level tokenization instead of char-level.
 - The average length of English words is 4.5 letters.
 - The sequences will be 4.5x shorter.
 - Shorter sequence → less likely to forget.

2. Word-Level Tokenization

- Word-level tokenization instead of char-level.
 - The average length of English words is 4.5 letters.
 - The sequences will be 4.5x shorter.
 - Shorter sequence → less likely to forget.
- But you will need a large dataset!
 - # of (frequently used) chars is $\sim 10^2$ → one-hot suffices.
 - # of (frequently used) words is $\sim 10^4$ → must use embedding.
 - Embedding Layer has many parameters → overfitting!

3. Multi-Task Learning

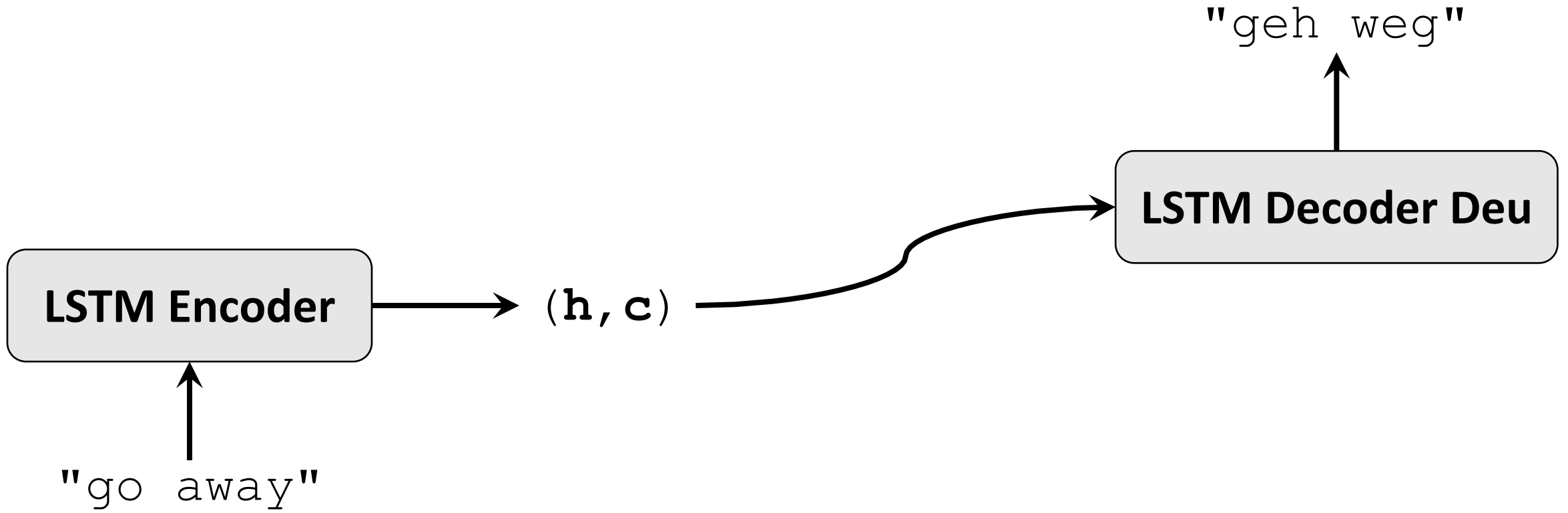



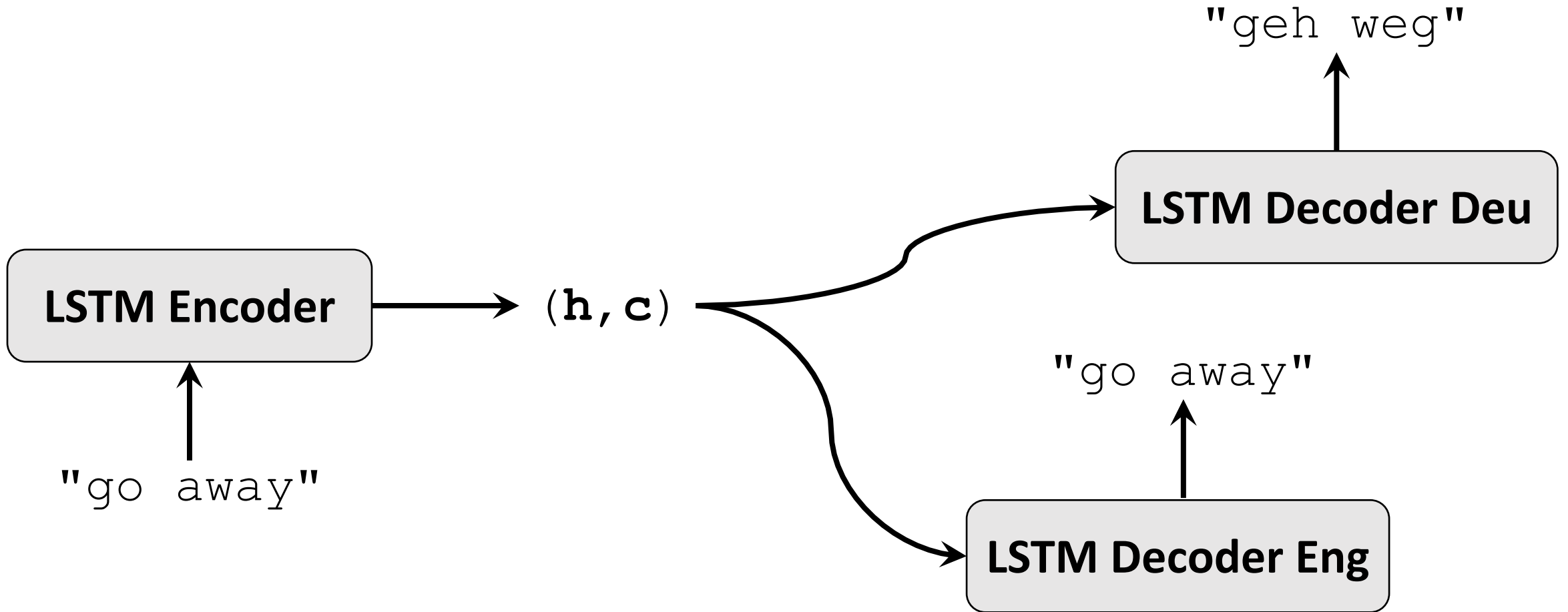

























3. Multi-Task Learning



3. Multi-Task Learning

- Even if you want to **translate English to German**, you can use all the datasets:

-  Afrikaans - English [afr-eng.zip](#) (725)
-  Aklanon - English [akl-eng.zip](#) (22)
-  Albanian - English [sqi-eng.zip](#) (412)
-  Algerian Arabic - English [arq-eng.zip](#) (156)
-  Arabic - English [ara-eng.zip](#) (11009)
-  Arabic (Gulf) - English [afb-eng.zip](#) (28)
-  Assamese - English [asm-eng.zip](#) (23)
-  Asturian - English [ast-eng.zip](#) (23)
-  Azerbaijani - English [aze-eng.zip](#) (2131)
-  Basque - English [eus-eng.zip](#) (667)
-  Belarusian - English [bel-eng.zip](#) (2698)
-  Bengali - English [ben-eng.zip](#) (4399)
-  Berber - English [ber-eng.zip](#) (54988)
-  Bulgarian - English [bul-eng.zip](#) (14968)
-  Spanish - English [spa-eng.zip](#) (120799)
-  Swedish - English [swe-eng.zip](#) (17409)
-  Tagalog - English [tgl-eng.zip](#) (3144)
-  Tamil - English [tam-eng.zip](#) (197)
-  Tatar - English [tat-eng.zip](#) (529)
-  Telugu - English [tel-eng.zip](#) (138)
-  Thai - English [tha-eng.zip](#) (110)
-  Turkish - English [tur-eng.zip](#) (497249)
-  Ukrainian - English [ukr-eng.zip](#) (113396)
-  Urdu - English [urd-eng.zip](#) (1180)
-  Uyghur - English [uig-eng.zip](#) (285)
-  Vietnamese - English [vie-eng.zip](#) (3413)
-  Waray - English [war-eng.zip](#) (1181)
-  Zaza - English [zza-eng.zip](#) (345)

3. Multi-Task Learning

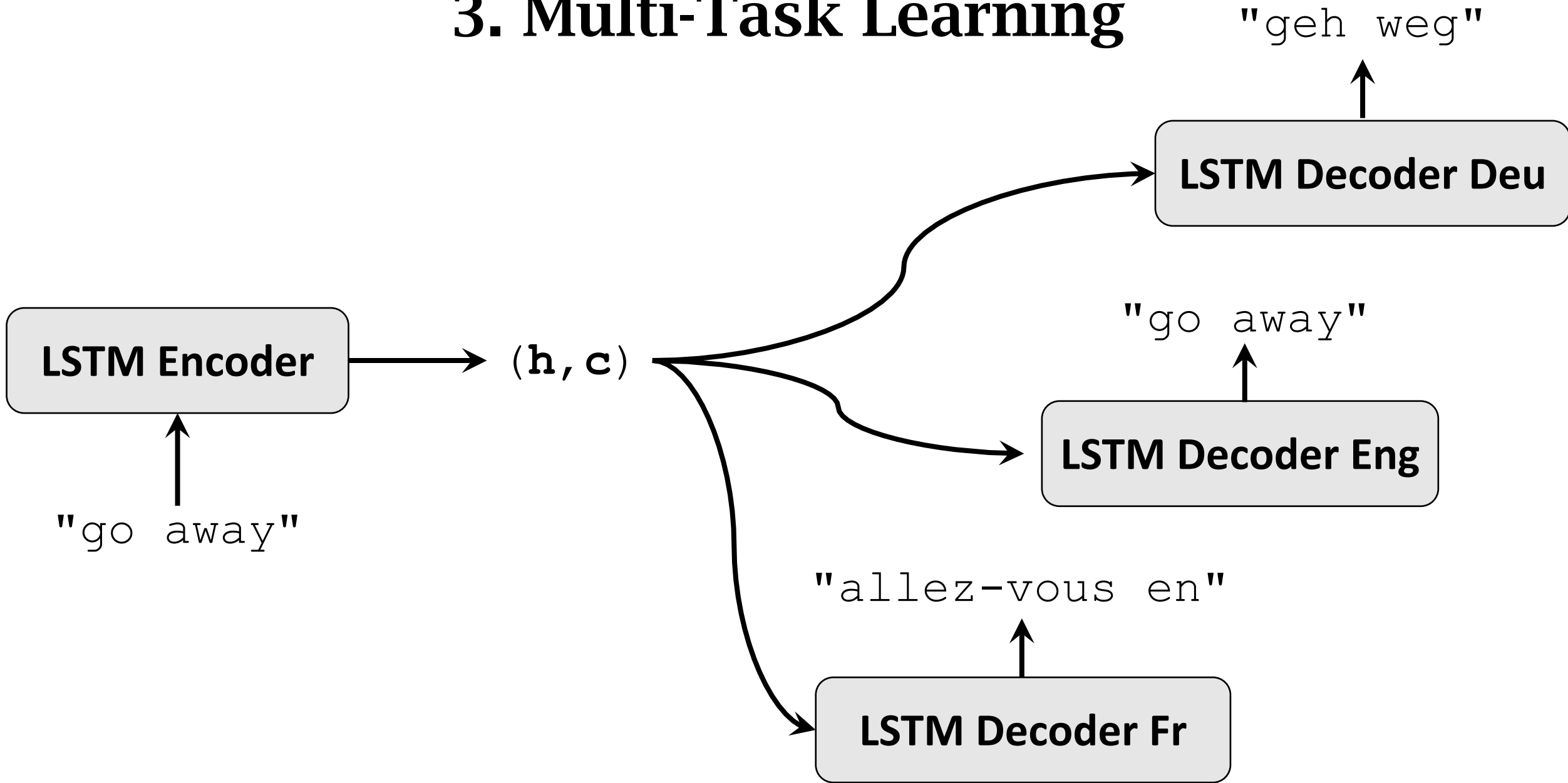

How to Improve?

1. Bi-LSTM instead of LSTM. (Encoder only!)
2. Tokenization in the word-level (instead of char-level.)
3. Multi-task learning.
4. Attention! (Next lecture.)

Homework 5

- Build a seq2seq model for machine translation.
 - Anything languages except for [English ==> German].
 - Follow my IPython Notebook.
- Make as least one improvement over my naïve model.
 - E.g., Bi-LSTM, attention, etc.
- Evaluate your model using BLEU score. (Optional.)
 - BLEU (BiLingual Evaluation Understudy).
 - Reference:
 - Wikipedia: <https://en.wikipedia.org/wiki/BLEU>
 - Blog: <https://machinelearningmastery.com/calculate-bleu-score-for-text-python/>

Homework 5

- You can get up to 2 bonus scores:
 - 1pt: attention
 - 1pt: BLEU score
- You will get a bonus score only if you do it right.
 - E.g., BLEU score should be around 0.1~0.5; over-high or over-low means something is wrong.
 - If your result looks obviously wrong, don't submit; it would be a waste of everyone's time.

Thank you!