

Chapter 6: WRF Data Assimilation

Table of Contents

- [Introduction](#)
- [Installing WRFDA for 3D-Var Run](#)
- [Installing WRFPLUS and WRFDA for 4D-Var Run](#)
- [Running Observation Preprocessor \(OBSPROC\)](#)
- [Running WRFDA](#)
- [Radiance Data Assimilation in WRFDA](#)
- [Precipitation Data Assimilation in WRFDA 4D-Var](#)
- [Updating WRF Boundary Conditions](#)
- [Running gen_be](#)
- [Additional WRFDA Exercises](#)
- [WRFDA with Multivariate Background Error \(MBE\) Statistics](#)
- [WRFDA Diagnostics](#)
- [Hybrid Data Assimilation](#)
- [ETKF Data Assimilation](#)
- [Description of Namelist Variables](#)

Introduction

Data assimilation is the technique by which **observations** are combined with an NWP product (the **first guess** or background forecast) and their respective error statistics to provide an improved estimate (the **analysis**) of the atmospheric (or oceanic, Jovian, etc.) state. Variational (Var) data assimilation achieves this through the iterative minimization of a prescribed cost (or penalty) function. Differences between the analysis and observations/first guess are penalized (damped) according to their perceived error. The difference between three-dimensional (3D-Var) and four-dimensional (4D-Var) data assimilation is the use of a numerical forecast model in the latter.

The MMM Division of NCAR supports a unified (global/regional, multi-model, 3/4D-Var) model-space data assimilation system (WRFDA) for use by the NCAR staff and collaborators, and is also freely available to the general community, together with further documentation, test results, plans etc., from the WRFDA web-page (<http://www.mmm.ucar.edu/wrf/users/wrfda/index.html>).

Various components of the WRFDA system are shown in blue in the sketch below, together with their relationship with the rest of the WRF system.

WRFDA in the WRF Modeling System

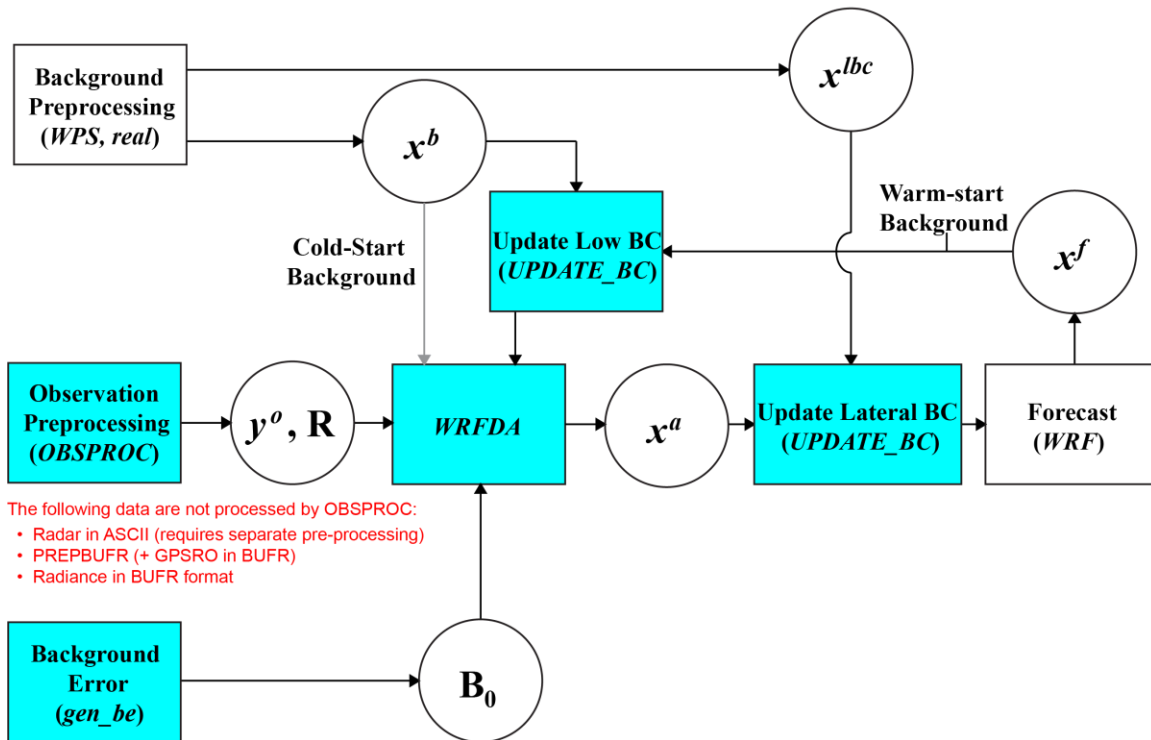

- x^b first guess, either from a previous WRF forecast or from WPS/REAL output.
- x^{lbc} lateral boundary from WPS/REAL output.
- x^a analysis from the WRFDA data assimilation system.
- x^f WRF forecast output.
- y^o observations processed by OBSPROC. (note: PREPBUFR input, radar, radiance, and rainfall data do not go through OBSPROC)
- B_0 background error statistics from generic BE data (CV3) or gen_be.
- R observational and representative error statistics.

In this chapter, you will learn how to install and run the various components of the WRFDA system. For training purposes, you are supplied with a test case, including the following input data:

- an observation file (which must be processed through OBSPROC),
- a netCDF background file (WPS/REAL output, the first guess of the analysis)
- background error statistics (estimate of errors in the background file).

This tutorial dataset can be downloaded from the WRFDA Users Page (<http://www.mmm.ucar.edu/wrf/users/wrfda/download/testdata.html>), and will be described later in more detail. In your own work, however, you will have to create all these input files yourself. See the section [Running Observation Preprocessor](#) for creating your observation files. See the section [Running gen_be](#) for generating your background error statistics file, if you want to use cv_options=5 or cv_options=6.

Before using your own data, we suggest that you start by running through the WRFDA-related programs using the supplied test case. This serves two purposes: First, you can learn how to run the programs with data we have tested ourselves, and second you can test whether your computer is capable of running the entire modeling system. After you have done the tutorial, you can try running other, more computationally intensive case studies, and experimenting with some of the many namelist variables.

WARNING: It is impossible to test every permutation of computer, compiler, number of processors, case, namelist option, etc. for every WRFDA release. The namelist options that are supported are indicated in the “`WRFDA/var/README.namelist`”, and these are the default options.

Hopefully, our test cases will prepare you for the variety of ways in which you may wish to run your own WRFDA experiments. Please inform us about your experiences.

As a professional courtesy, we request that you include the following references in any publication that uses any component of the community WRFDA system:

Barker, D.M., W. Huang, Y.R. Guo, and Q.N. Xiao., 2004: A Three-Dimensional (3DVAR) Data Assimilation System For Use With MM5: Implementation and Initial Results. *Mon. Wea. Rev.*, **132**, 897-914.

Huang, X.Y., Q. Xiao, D.M. Barker, X. Zhang, J. Michalakes, W. Huang, T. Henderson, J. Bray, Y. Chen, Z. Ma, J. Dudhia, Y. Guo, X. Zhang, D.J. Won, H.C. Lin, and Y.H. Kuo, 2009: Four-Dimensional Variational Data Assimilation for WRF: Formulation and Preliminary Results. *Mon. Wea. Rev.*, **137**, 299–314.

Barker, D., X.-Y. Huang, Z. Liu, T. Auligné, X. Zhang, S. Rugg, R. Ajjaji, A. Bourgeois, J. Bray, Y. Chen, M. Demirtas, Y.-R. Guo, T. Henderson, W. Huang, H.-C. Lin, J. Michalakes, S. Rizvi, and X. Zhang, 2012: The Weather Research and Forecasting Model's Community Variational/Ensemble Data Assimilation System: WRFDA. *Bull. Amer. Meteor. Soc.*, **93**, 831–843.

Running WRFDA requires a Fortran 90 compiler. We have tested the WRFDA system on the following platforms: IBM (XLF), SGI Altix (INTEL), PC/Linux (INTEL, GFORTTRAN, PGI), and Macintosh (G95/PGI). Please let us know if this does not meet your requirements, and we will attempt to add other machines to our list of supported architectures, as resources allow. Although we are interested in hearing about your experiences in modifying compiler options, we do not recommend making changes to the configure file used to compile WRFDA.

Installing WRFDA for 3D-Var Run

a. Obtaining WRFDA Source Code

Users can download the WRFDA source code from http://www.mmm.ucar.edu/wrf/users/wrfda/download/get_source.html.

Note: WRF compiles with the `-r4` option while WRFDA compiles with `-r8`. For this reason, WRF and WRFDA cannot reside or be compiled in the same directory.

After the tar file is unzipped (`gunzip WRFDAV3.5.TAR.gz`) and untarred (`tar -xf WRFDAV3.5.TAR`), the directory `WRFDA` should be created. This directory contains the WRFDA source, external libraries, and fixed files. The following is a list of the system components and content for each subdirectory:

Directory Name	Content
<code>var/da</code>	WRFDA source code
<code>var/run</code>	Fixed input files required by WRFDA, such as background error covariance, radiance-related files, CRTM coefficients and <code>VARBC.in</code>
<code>var/external</code>	Libraries needed by WRFDA, includes CRTM, BUFR, LAPACK, BLAS
<code>var/obsproc</code>	OBSPROC source code, namelist, and observation error files
<code>var/gen_be</code>	Source code of <code>gen_be</code> , the utility to create background error statistics files
<code>var/build</code>	Builds all <code>.exe</code> files.

b. Compile WRFDA and Libraries

Some external libraries (e.g., LAPACK, BLAS, and NCEP BUFR) are included in the WRFDA tar file. To compile the WRFDA code, the only mandatory library is the netCDF library. You should set an environment variable `NETCDF` to point to the directory where your netCDF library is installed

```
> setenv NETCDF your_netcdf_path
```

If observational data in BUFR or PREPBUFR format are to be used, the NCEP BUFR library must be compiled, and BUFR-related WRFDA code must be generated and compiled. To do this, set the environment variable `BUFR` before compiling:

```
> setenv BUFR 1
```

If satellite radiance data are to be used, a Radiative Transfer Model (RTM) is required. The current RTM versions that WRFDA supports are CRTM V2.0.2 and RTTOV V10.2. WRFDA can be compiled with either of these, or both together, but only one may be used for each individual assimilation run.

CRTM V2.0.2 is included in the WRFDA tar file. To have the CRTM library and the CRTM-related WRFDA code compiled, set the environment variable CRTM before compiling WRFDA:

```
> setenv CRTM 1
```

If the user wishes to use RTTOV, download and install the RTTOV v10 library before compiling WRFDA. This library can be downloaded from <http://research.metoffice.gov.uk/research/interproj/nwpsaf/rtm>. **The RTTOV libraries must be compiled with the “emis_atlas” option in order to work with WRFDA.** After compiling RTTOV (see the RTTOV documentation for detailed instructions), set the “RTTOV” environment variable to the path where the `lib` directory resides. For example, if the library files can be found in

`/usr/local/rttov10/pgi/lib/librttov10.2.0_*.a`, you should set RTTOV as:

```
> setenv RTTOV /usr/local/rttov10/pgi
```

Note: Make sure the required libraries were all compiled using the same compiler that will be used to build WRFDA, since the libraries produced by one compiler may not be compatible with code compiled with another.

Assuming all required libraries are available and the WRFDA source code is ready, you can start to build WRFDA using the following steps:

Enter the WRFDA directory and run the configure script:

```
> cd WRFDA
> ./configure wrfda
```

A list of configuration options should appear. Each option combines an operating system, a compiler type, and a parallelism option. Since the configuration script doesn't check which compilers are *actually* installed on your system, be sure to select only among the options that you have available to you. The available parallelism options are single-processor (serial), shared-memory parallel (smpar), distributed-memory parallel (dmpar), and distributed-memory with shared-memory parallel (sm+dm). **However, shared-memory (smpar and sm+dm) options are not supported as of WRFDA Version 3.5, so we do not recommend selecting any of these options.**

For example, on a Linux machine such as NCAR's Yellowstone, the above steps will look similar to the following:

```
> ./configure wrfda
checking for perl5... no
checking for perl... found /usr/bin/perl (perl)
Will use NETCDF in dir: /glade/apps/opt/netcdf/4.2/intel/default
PHDF5 not set in environment. Will configure WRF for use without.
$JASPERLIB or $JASPERINC not found in environment, configuring to build without
grib2 I/O...
```

Please select from among the following supported platforms.

1. Linux x86_64 i486 i586 i686, PGI compiler with gcc (serial)
2. Linux x86_64 i486 i586 i686, PGI compiler with gcc (smpar)
3. Linux x86_64 i486 i586 i686, PGI compiler with gcc (dmpar)
4. Linux x86_64 i486 i586 i686, PGI compiler with gcc (dm+sm)
5. Linux x86_64 i486 i586 i686 PGI compiler with pgcc YELLOWSTONE (serial)
6. Linux x86_64 i486 i586 i686 PGI compiler with pgcc YELLOWSTONE (smpar)
7. Linux x86_64 i486 i586 i686 PGI compiler with pgcc YELLOWSTONE (dmpar)
8. Linux x86_64 i486 i586 i686 PGI compiler with pgcc YELLOWSTONE (dm+sm)
9. Linux x86_64, PGI compiler with pgcc, SGI MPT (serial)
10. Linux x86_64, PGI compiler with pgcc, SGI MPT (smpar)
11. Linux x86_64, PGI compiler with pgcc, SGI MPT (dmpar)
12. Linux x86_64, PGI compiler with pgcc, SGI MPT (dm+sm)
13. Linux x86_64, PGI accelerator compiler with gcc (serial)
14. Linux x86_64, PGI accelerator compiler with gcc (smpar)
15. Linux x86_64, PGI accelerator compiler with gcc (dmpar)
16. Linux x86_64, PGI accelerator compiler with gcc (dm+sm)
17. Linux x86_64 i486 i586 i686, ifort compiler with icc (serial)
18. Linux x86_64 i486 i586 i686, ifort compiler with icc (smpar)
19. Linux x86_64 i486 i586 i686, ifort compiler with icc (dmpar)
20. Linux x86_64 i486 i586 i686, ifort compiler with icc (dm+sm)
21. Linux x86_64 i486 i586 i686, Xeon Phi (MIC architecture) ifort compiler with icc (dm+sm)
22. Linux x86_64 i486 i586 i686, Xeon (SNB with AVX mods) ifort compiler with icc (serial)
23. Linux x86_64 i486 i586 i686, Xeon (SNB with AVX mods) ifort compiler with icc (smpar)
24. Linux x86_64 i486 i586 i686, Xeon (SNB with AVX mods) ifort compiler with icc (dmpar)
25. Linux x86_64 i486 i586 i686, Xeon (SNB with AVX mods) ifort compiler with icc (dm+sm)
26. Linux x86_64 i486 i586 i686, ifort compiler with icc YELLOWSTONE (serial)
27. Linux x86_64 i486 i586 i686, ifort compiler with icc YELLOWSTONE (smpar)
28. Linux x86_64 i486 i586 i686, ifort compiler with icc YELLOWSTONE (dmpar)
29. Linux x86_64 i486 i586 i686, ifort compiler with icc YELLOWSTONE (dm+sm)
30. Linux x86_64 i486 i586 i686, ifort compiler with icc, SGI MPT (serial)
31. Linux x86_64 i486 i586 i686, ifort compiler with icc, SGI MPT (smpar)
32. Linux x86_64 i486 i586 i686, ifort compiler with icc, SGI MPT (dmpar)
33. Linux x86_64 i486 i586 i686, ifort compiler with icc, SGI MPT (dm+sm)
34. Linux x86_64 i486 i586 i686, ifort compiler with icc, IBM POE (serial)
35. Linux x86_64 i486 i586 i686, ifort compiler with icc, IBM POE (smpar)
36. Linux x86_64 i486 i586 i686, ifort compiler with icc, IBM POE (dmpar)
37. Linux x86_64 i486 i586 i686, ifort compiler with icc, IBM POE (dm+sm)
38. Linux i486 i586 i686 x86_64, PathScale compiler with pathcc (serial)
39. Linux i486 i586 i686 x86_64, PathScale compiler with pathcc (dmpar)
40. x86_64 Linux, gfortran compiler with gcc (serial)
41. x86_64 Linux, gfortran compiler with gcc (smpar)

-
- ```

42. x86_64 Linux, gfortran compiler with gcc (dmpar)
43. x86_64 Linux, gfortran compiler with gcc (dm+sm)

```

```
Enter selection [1-43] : 28
```

```

Compile for nesting? (1=basic, 2=preset moves, 3=vortex following) [default 1]:
Configuration successful. To build the model type compile .

```

```
... ..
```

After running the configuration script and choosing a compilation option, a `configure.wrf` file will be created. Because of the variety of ways that a computer can be configured, if the WRFDA build ultimately fails, there is a chance that minor modifications to the `configure.wrf` file may be needed.

**Hint:** It is helpful to start with something simple, such as the serial build. If it is successful, move on to build `dmpar` code. Remember to type `'clean -a'` between each build to remove the old settings and executable files.

To compile WRFDA, type

```
> ./compile all_wrfvar >&! compile.out
```

Successful compilation will produce 44 executables: 43 of which are in the `var/build` directory and linked in the `var/da` directory, with the 44th, `obsproc.exe`, found in the `var/obsproc/src` directory. You can list these executables by issuing the command:

```
>ls -l var/build/*exe var/obsproc/src/obsproc.exe
-rwxr-xr-x 1 user 885143 Apr 4 17:22 var/build/da_advance_time.exe
-rwxr-xr-x 1 user 1162003 Apr 4 17:24 var/build/da_bias_airmass.exe
-rwxr-xr-x 1 user 1143027 Apr 4 17:23 var/build/da_bias_scan.exe
-rwxr-xr-x 1 user 1116933 Apr 4 17:23 var/build/da_bias_sele.exe
-rwxr-xr-x 1 user 1126173 Apr 4 17:23 var/build/da_bias_verif.exe
-rwxr-xr-x 1 user 1407973 Apr 4 17:23 var/build/da_rad_diags.exe
-rwxr-xr-x 1 user 1249431 Apr 4 17:22 var/build/da_tune_obs_desroziers.exe
-rwxr-xr-x 1 user 1186368 Apr 4 17:24 var/build/da_tune_obs_hollingsworth1.exe
-rwxr-xr-x 1 user 1083862 Apr 4 17:24 var/build/da_tune_obs_hollingsworth2.exe
-rwxr-xr-x 1 user 1193390 Apr 4 17:24 var/build/da_update_bc_ad.exe
-rwxr-xr-x 1 user 1245842 Apr 4 17:23 var/build/da_update_bc.exe
-rwxr-xr-x 1 user 1492394 Apr 4 17:24 var/build/da_verif_grid.exe
-rwxr-xr-x 1 user 1327002 Apr 4 17:24 var/build/da_verif_obs.exe
-rwxr-xr-x 1 user 26031927 Apr 4 17:31 var/build/da_wrfvar.exe
-rwxr-xr-x 1 user 1933571 Apr 4 17:23 var/build/gen_be_addmean.exe
-rwxr-xr-x 1 user 1944047 Apr 4 17:24 var/build/gen_be_cov2d3d_contrib.exe
-rwxr-xr-x 1 user 1927988 Apr 4 17:24 var/build/gen_be_cov2d.exe
-rwxr-xr-x 1 user 1945213 Apr 4 17:24 var/build/gen_be_cov3d2d_contrib.exe
-rwxr-xr-x 1 user 1941439 Apr 4 17:24 var/build/gen_be_cov3d3d_bin3d_contrib.exe
-rwxr-xr-x 1 user 1947331 Apr 4 17:24 var/build/gen_be_cov3d3d_contrib.exe
-rwxr-xr-x 1 user 1931820 Apr 4 17:24 var/build/gen_be_cov3d.exe
-rwxr-xr-x 1 user 1915177 Apr 4 17:24 var/build/gen_be_diags.exe
-rwxr-xr-x 1 user 1947942 Apr 4 17:24 var/build/gen_be_diags_read.exe
-rwxr-xr-x 1 user 1930465 Apr 4 17:24 var/build/gen_be_ensmean.exe
-rwxr-xr-x 1 user 1951511 Apr 4 17:24 var/build/gen_be_ensrf.exe
-rwxr-xr-x 1 user 1994167 Apr 4 17:24 var/build/gen_be_ep1.exe
-rwxr-xr-x 1 user 1996438 Apr 4 17:24 var/build/gen_be_ep2.exe
-rwxr-xr-x 1 user 2001400 Apr 4 17:24 var/build/gen_be_etkf.exe
-rwxr-xr-x 1 user 1942988 Apr 4 17:24 var/build/gen_be_hist.exe
-rwxr-xr-x 1 user 2021659 Apr 4 17:24 var/build/gen_be_stage0_gsi.exe

```



```
-rwxr-xr-x 1 user 2012035 Apr 4 17:24 var/build/gen_be_stage0_wrf.exe
-rwxr-xr-x 1 user 1973193 Apr 4 17:24 var/build/gen_be_stage1_ldvar.exe
-rwxr-xr-x 1 user 1956835 Apr 4 17:24 var/build/gen_be_stage1.exe
-rwxr-xr-x 1 user 1963314 Apr 4 17:24 var/build/gen_be_stage1_gsi.exe
-rwxr-xr-x 1 user 1975042 Apr 4 17:24 var/build/gen_be_stage2_ldvar.exe
-rwxr-xr-x 1 user 1938468 Apr 4 17:24 var/build/gen_be_stage2a.exe
-rwxr-xr-x 1 user 1952538 Apr 4 17:24 var/build/gen_be_stage2.exe
-rwxr-xr-x 1 user 1202392 Apr 4 17:22 var/build/gen_be_stage2_gsi.exe
-rwxr-xr-x 1 user 1947836 Apr 4 17:24 var/build/gen_be_stage3.exe
-rwxr-xr-x 1 user 1928353 Apr 4 17:24 var/build/gen_be_stage4_global.exe
-rwxr-xr-x 1 user 1955622 Apr 4 17:24 var/build/gen_be_stage4_regional.exe
-rwxr-xr-x 1 user 1924416 Apr 4 17:24 var/build/gen_be_vertloc.exe
-rwxr-xr-x 1 user 2057673 Apr 4 17:24 var/build/gen_mbe_stage2.exe
-rwxr-xr-x 1 user 2110993 Apr 4 17:32 var/obsproc/src/obsproc.exe
```

The main executable for running WRFDA is `da_wrfvar.exe`. Make sure it has been created after the compilation: it is common that all the executables will be successfully compiled except this main executable. If this occurs, please check the compilation log file carefully for any errors.

The basic `gen_be` utility for the regional model consists of `gen_be_stage0_wrf.exe`, `gen_be_stage1.exe`, `gen_be_stage2.exe`, `gen_be_stage2a.exe`, `gen_be_stage3.exe`, `gen_be_stage4_regional.exe`, and `gen_be_diags.exe`.

`da_update_bc.exe` is used for updating the WRF lower and lateral boundary conditions before and after a new WRFDA analysis is generated.

`da_advance_time.exe` is a very handy and useful tool for date/time manipulation. Type `$WRFDA_DIR/var/build/da_advance_time.exe` to see its usage instructions.

`obsproc.exe` is the executable for preparing conventional observations for assimilation by WRFDA.

If you specified that BUFR or CRTM libraries were needed, check `$WRFDA_DIR/var/external/bufr` and `$WRFDA_DIR/var/external/crtm/libsrc` to ensure `libbufr.a` and `libCRTM.a` were generated.

### c. Clean Compilation

To remove all object files and executables, type:

```
./clean
```

To remove all build files, including `configure.wrfda`, type:

```
./clean -a
```

The `clean -a` command is recommended if your compilation fails, or if the configuration file has been changed and you wish to restore the default settings.



## Installing WRFPLUS and WRFDA for 4D-Var Run

If you intend to run WRF 4D-Var, it is necessary to have WRFPLUS installed. WRFPLUS contains the adjoint and tangent linear models based on a simplified WRF model, which includes a few simplified physics packages, such as surface drag, large scale condensation and precipitation, and cumulus parameterization. As of V3.4, WRF 4D-Var can be compiled run in parallel.

To install WRFPLUS:

- Get the WRFPLUS zipped tar file from <http://www.mmm.ucar.edu/wrf/users/wrfda/download/wrfplus.html>
- Unzip and untar the WRFPLUS file, then run the `configure` script

```
> gunzip WRFPLUSV3.5.TAR.gz
> tar -xf WRFPLUSV3.5.TAR
> cd WRFPLUSV3
> ./configure wrfplus
```

As with 3D-Var, “serial” means single-processor, and “dmpar” means Distributed Memory Parallel (MPI). Be sure to select the same option for WRFPLUS as you will use for WRFDA.

- Compile WRFPLUS

```
> ./compile em_real >&! compile.out
> ls -ls main/*.exe
```

You should see the following files:

```
-rwxr-xr-x 1 user users 23179920 Apr 3 15:22 main/ndown.exe
-rwxr-xr-x 1 user users 22947466 Apr 3 15:22 main/nup.exe
-rwxr-xr-x 1 user users 23113961 Apr 3 15:22 main/real.exe
-rwxr-xr-x 1 user users 22991725 Apr 3 15:22 main/tc.exe
-rwxr-xr-x 1 user users 32785447 Apr 3 15:20 main/wrf.exe
```

Finally, set the environment variable `WRFPLUS_DIR` to the appropriate directory:

```
>setenv WRFPLUS_DIR ${your_source_code_dir}/WRFPLUSV3
```

To install WRFDA for the 4D-Var run:

- If you intend to use observational data in BUFR or PREPBUFR format, or if you

intend to assimilate satellite radiance data, you need to set environment variables for BUFR, CRTM, and/or RTTOV. See the previous 3D-Var section for instructions.

```
>./configure 4dvar
```

- Starting with V3.4, WRFDA 4D-Var may be compiled to run in parallel mode.

```
>./compile all_wrfvar >& compile.out
>ls -ls var/build/*.exe var/obsproc/*.exe
```

You should see the same 44 executables as are listed in the above 3D-Var section, including `da_wrfvar.exe`

## Running Observation Preprocessor (OBSPROC)

The OBSPROC program reads observations in LITTLE\_R format (a text-based format, in use since the MM5 era). We have provided observations for the tutorial case, but for your own applications, you will have to prepare your own observation files. Please see [http://www.mmm.ucar.edu/wrf/users/wrfda/download/free\\_data.html](http://www.mmm.ucar.edu/wrf/users/wrfda/download/free_data.html) for the sources of some freely-available observations. Because the raw observation data files have many possible formats, such as ASCII, BUFR, PREPBUFR, MADIS, and HDF, the free data site also contains instructions for converting the observations to LITTLE\_R format. To make the WRFDA system as general as possible, the LITTLE\_R format was adopted as an intermediate observation data format for the WRFDA system, however, *the conversion of the user-specific source data to LITTLE\_R format is the user's task*. A more complete description of the LITTLE\_R format, as well as conventional observation data sources for WRFDA, can be found by reading the “Observation Pre-processing” tutorial found at [http://www.mmm.ucar.edu/wrf/users/wrfda/Tutorials/2012\\_July/tutorial\\_presentation\\_summer\\_2012.html](http://www.mmm.ucar.edu/wrf/users/wrfda/Tutorials/2012_July/tutorial_presentation_summer_2012.html), or by referencing [Chapter 7 of this User's Guide](#).

The purpose of OBSPROC is to:

- Remove observations outside the specified temporal and spatial domains
- Re-order and merge duplicate (in time and location) data reports
- Retrieve pressure or height based on observed information using the hydrostatic assumption
- Check multi-level observations for vertical consistency and superadiabatic conditions
- Assign observation errors based on a pre-specified error file
- Write out the observation file to be used by WRFDA in ASCII or BUFR format

The OBSPROC program (`obsproc.exe`) should be found under the directory

`$WRFDA_DIR/var/obsproc/src` if “`compile all_wrfvar`” completed successfully.

If you haven’t already, you should download the tutorial case, which contains example files for all the exercises in this User’s Guide. The case can be found at the WRFDA website (<http://www.mmm.ucar.edu/wrf/users/wrfda/download/testdata.html>).

### a. Prepare observational data for 3D-Var

As an example, to prepare the observation file at the analysis time, all the observations in the range  $\pm 1h$  will be processed, which means that (in the example case) the observations between 23h and 1h are treated as the observations at 0h. This is illustrated in the following figure:

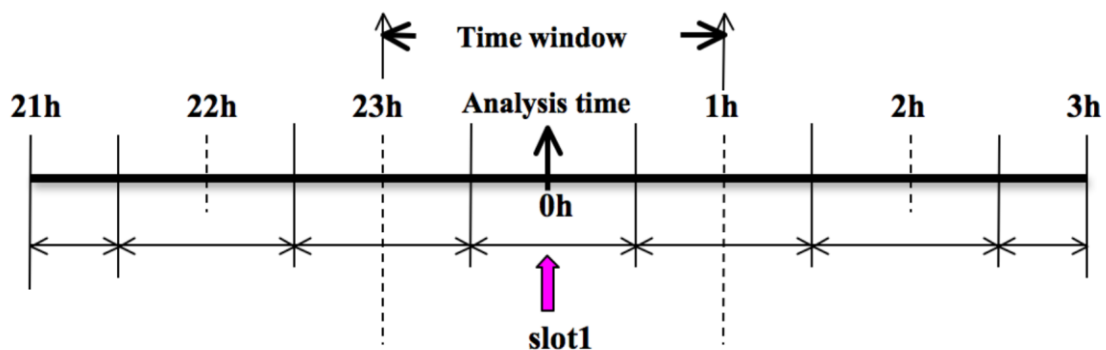

OBSPROC requires at least 3 files to run successfully:

- A namelist file (`namelist.obsproc`)
- An observation error file (`obserr.txt`)
- One or more observation files

To create the required namelist file, we have provided an example file `namelist_obsproc.3dvar.wrfvar-tut` in the `var/obsproc` directory. Thus, proceed as follows.

```
> cd $WRFDA_DIR/var/obsproc
> cp namelist.obsproc.3dvar.wrfvar-tut namelist.obsproc
```

Next, edit the namelist file, `namelist.obsproc`, to accommodate your experiments. You will likely only need to change variables listed under records 1, 2, 6, 7, and 8. See `$WRFDA_DIR/var/obsproc/README.namelist`, or the section [Description of Namelist Variables](#) for details; you should pay special attention to NESTIX and NESTJX.

If you are running the tutorial case, you should copy or link the sample observation file (`ob/2008020512/obs.2008020512`) to the `obsproc` directory. Alternatively, you can edit the namelist variable `obs_gts_filename` to point to the observation file’s full path.

To run OBSPROC, type

```
> ./obsproc.exe >&! obsproc.out
```

Once `obsproc.exe` has completed successfully, you will see an observation data file, with the name formatted `obs_gts_YYYY-MM-DD_HH:NN:SS.3DVAR`, in the `obsproc` directory. For the tutorial case, this will be `obs_gts_2008-02-05_12:00:00.3DVAR`. This is the input observation file to WRFDA. It is an ASCII file that contains a header section (listed below) followed by observations. The meanings and format of observations in the file are described in the last six lines of the header section.

```
TOTAL = 9066, MISS. = -888888.,
SYNOP = 757, METAR = 2416, SHIP = 145, BUOY = 250, BOGUS = 0, TEMP =
86,
AMDAR = 19, AIREP = 205, TAMDAR = 0, PILOT = 85, SATEM = 106, SATOB =
2556,
GPSFW = 187, GPSZD = 0, GPSRF = 3, GPSEP = 0, SSMT1 = 0, SSMT2 =
0,
TOVS = 0, QSCAT = 2190, PROFL = 61, AIRSR = 0, OTHER = 0,
PHIC = 40.00, XLONC = -95.00, TRUE1 = 30.00, TRUE2 = 60.00, XIM11 = 1.00, XJM11 =
1.00,
base_temp= 290.00, base_lapse= 50.00, PTOP = 1000., base_pres=100000.,
base_tropo_pres= 20000., base_strat_temp= 215.,
IXC = 60, JXC = 90, IPROJ = 1, IDD = 1, MAXNES= 1,
NESTIX= 60,
NESTJX= 90,
NUMC = 1,
DIS = 60.00,
NESTI = 1,
NESTJ = 1,
INFO = PLATFORM, DATE, NAME, LEVELS, LATITUDE, LONGITUDE, ELEVATION, ID.
SRFC = SLP, PW (DATA, QC, ERROR).
EACH = PRES, SPEED, DIR, HEIGHT, TEMP, DEW PT, HUMID (DATA, QC, ERROR) *LEVELS.
INFO_FMT = (A12, 1X, A19, 1X, A40, 1X, I6, 3 (F12.3, 11X), 6X, A40)
SRFC_FMT = (F12.3, I4, F7.2, F12.3, I4, F7.3)
EACH_FMT = (3 (F12.3, I4, F7.2), 11X, 3 (F12.3, I4, F7.2), 11X, 3 (F12.3, I4, F7.2))
#-----#
..... observations
```

Before running WRFDA, you may find it useful to learn more about various types of data that will be processed (e.g., their geographical distribution). This file is in ASCII format and so you can easily view it. For a graphical view of the file's content, use the `MAP_plot` utility to see the data distribution for each type of observation. To use this utility, proceed to the `MAP_plot` directory, then compile by typing “make”.

If the build fails, it is likely due to an improper configuration file. By viewing the contents of the `MAP_plot` directory, you will see we have prepared some `configure.user.ibm/OS` files (where OS is the type of operating system) for some platforms. When “make” is typed, the Makefile uses one of them to determine the compiler and compiler option. Modify the Makefile and `configure.user.xxx` to accommodate the compiler on your platform, then type “make” to attempt the compilation again. Successful compilation will produce `Map.exe`. The following instructions are for the tutorial case, but can easily be configured for your own data by changing the appropriate dates

and file names.

**Note:** The successful compilation of `Map.exe` requires pre-installed NCARG Graphics libraries under `$(NCARG_ROOT)/lib`.

Modify the script `Map.csh` to set the time window and full path of the input observation file (`obs_gts_2008-02-05_12:00:00.3DVAR`). You will need to set the following strings in this script as follows:

```
Map_plot = $WRFDA_DIR/var/obsproc/MAP_plot
TIME_WINDOW_MIN = '2008020511'
TIME_ANALYSIS = '2008020512'
TIME_WINDOW_MAX = '2008020513'
OBSDATA = ../obs_gts_2008-02-05_12:00:00.3DVAR
```

Next, type `Map.csh` to run the script

When the job has completed, you will have a `gmeta` file, `gmeta.2008020512`. This contains plots of data distribution for each type of observation contained in the OBS data file: `obs_gts_2008-02-05_12:00:00.3DVAR`. To view this, type

```
> idt gmeta.2008020512
```

It will display a panel-by-panel geographical distribution of various types of data. The following graphic shows the geographic distribution of sonde observations for this case.

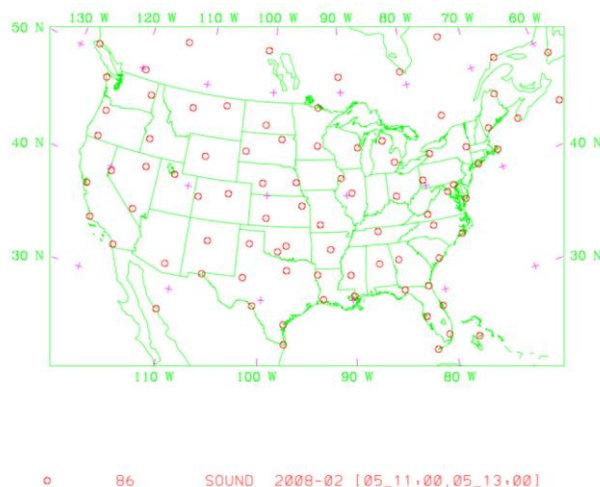

An alternative way to plot the observations is to use an NCL script (for more information on NCL, the NCAR Command Language, see <http://www.ncl.ucar.edu/>). In the WRFDA Tools package (can be downloaded at <http://www.mmm.ucar.edu/wrf/users/wrfda/download/tools.html>), this script is located at `$TOOLS_DIR/var/graphics/ncl/plot_ob_ascii_loc.ncl`. With this method, however, you need to provide the first guess file to the NCL script, and have NCL installed in

your system.

## b. Prepare observational data for 4D-Var

To prepare the observation file, for example, at the analysis time 0h for 4D-Var, all observations from 0h to 6h will be processed and grouped in 7 sub-windows (slot1 through slot7) as illustrated in the following figure:

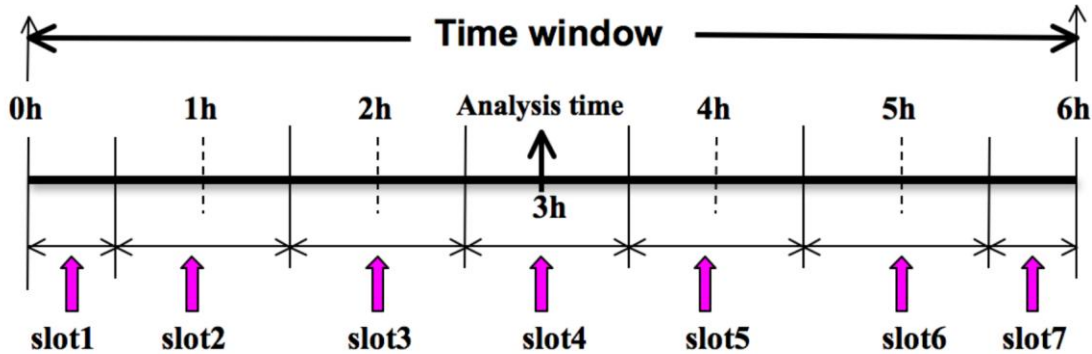

NOTE: The “Analysis time” in the above figure is not the actual analysis time (0h). It indicates the `time_analysis` setting in the namelist file, which in this example is three hours later than the actual analysis time. The actual analysis time is still 0h.

An example file (`namelist_obsproc.4dvar.wrfvar-tut`) has already been provided in the `var/obsproc` directory. Thus, proceed as follows:

```
> cd $WRFDA_DIR/var/obsproc
> cp namelist_obsproc.4dvar.wrfvar-tut namelist_obsproc
```

In the namelist file, you need to change the following variables to accommodate your experiments. In this tutorial case, the actual analysis time is `2008-02-05_12:00:00`, **but in the namelist, `time_analysis` should be set to 3 hours later**. The different values of `time_analysis`, `num_slots_past`, and `time_slots_ahead` contribute to the actual times analyzed. For example, if you set `time_analysis = 2008-02-05_16:00:00`, and set the `num_slots_past = 4` and `time_slots_ahead=2`, the final results will be the same as before.

Edit all the domain settings according to your own experiment. You should pay special attention to NESTIX and NESTJX, which is described in the section [Description of Namelist Variables](#) for details.

If you are running the tutorial case, you should copy or link the sample observation file (`ob/2008020512/obs.2008020512`) to the `obsproc` directory. Alternatively, you can

edit the namelist variable `obs_gts_filename` to point to the observation file's full path.

To run OBSPROC, type

```
> obsproc.exe >&! obsproc.out
```

Once `obsproc.exe` has completed successfully, you will see 7 observation data files, which for the tutorial case are named

```
obs_gts_2008-02-05_12:00:00.4DVAR
obs_gts_2008-02-05_13:00:00.4DVAR
obs_gts_2008-02-05_14:00:00.4DVAR
obs_gts_2008-02-05_15:00:00.4DVAR
obs_gts_2008-02-05_16:00:00.4DVAR
obs_gts_2008-02-05_17:00:00.4DVAR
obs_gts_2008-02-05_18:00:00.4DVAR
```

They are the input observation files to WRF 4D-Var. As with 3D-Var, you can use `MAP_Plot` to view the geographic distribution of different observations at different time slots.

## Running WRFDA

### a. Download Test Data

The WRFDA system requires three input files to run:

- a) WRF *first guess* and *boundary* input files, output from either WPS/real (cold-start) or a WRF forecast (warm-start)
- b) Observations (in ASCII format, PREPBUFR or BUFR for radiance)
- c) A background error statistics file (containing background error covariance)

The following table summarizes the above info:

| <i>Input Data</i>                  | <i>Format</i>                     | <i>Created By</i>                                       |
|------------------------------------|-----------------------------------|---------------------------------------------------------|
| <b>First Guess</b>                 | NETCDF                            | WRF Preprocessing System (WPS) and real.exe or WRF      |
| <b>Observations</b>                | ASCII<br>(PREPBUFR also possible) | <a href="#">Observation Preprocessor</a><br>(OBSPROC)   |
| <b>Background Error Statistics</b> | Binary                            | <a href="#">WRFDA gen. be utility</a><br>or generic CV3 |



In the test case, you will store data in a directory defined by the environment variable `$DAT_DIR`. This directory can be in any location, and it should have read access. Type

```
> setenv DAT_DIR your_choice_of_dat_dir
```

Here, `your_choice_of_dat_dir` is the directory where the WRFDA input data is stored.

If you have not already done so, download the example data for the tutorial case, valid at 12 UTC 5<sup>th</sup> February 2008, from

<http://www.mmm.ucar.edu/wrf/users/wrfda/download/testdata.html>

Once you have downloaded the `WRFDAV3.5-testdata.tar.gz` file to `$DAT_DIR`, extract it by typing

```
> gunzip WRFDAV3.5-testdata.tar.gz
> tar -xvf WRFDAV3.5-testdata.tar
```

Now you should find the following four files under “`$DAT_DIR`”

```
ob/2008020512/ob.2008020512 # Observation data in "little_r" format
rc/2008020512/wrfinput_d01 # First guess file
rc/2008020512/wrfbdy_d01 # lateral boundary file
be/be.dat # Background error file
.....
```

At this point you should have three of the input files (first guess, observations from OBSPROC, and background error statistics files in the directory `$DAT_DIR`) required to run WRFDA, and have successfully downloaded and compiled the WRFDA code. If this is correct, you are ready to learn how to run WRFDA.

## **b. Run the Case—3D-Var**

The data for the tutorial case is valid at 12 UTC 5 February 2008. The first guess comes from the NCEP FNL (Final) Operational Global Analysis data, passed through the WRF-WPS and *real* programs.

To run WRF 3D-Var, first create and enter into a working directory (for example, `$WRFDA_DIR/workdir`), and set the environment variable `WORK_DIR` to this directory (e.g., `setenv WORK_DIR $WRFDA_DIR/workdir`). Then follow the steps below:

```
> cd $WORK_DIR
> cp $WRFDA_DIR/var/test/tutorial/namelist.input .
> ln -sf $WRFDA_DIR/run/LANDUSE.TBL .
> ln -sf $DAT_DIR/rc/2008020512/wrfinput_d01 ./fg
> ln -sf $WRFDA_DIR/var/obsproc/obs_gts_2008-02-05_12:00:00.3DVAR
./ob.ascii (note the different name!)
> ln -sf $DAT_DIR/be/be.dat .
> ln -sf $WRFDA_DIR/var/da/da_wrfvar.exe .
```

---

Now edit the file `namelist.input`, which is a very basic namelist for the tutorial test case, and is shown below.

```
&wrfvar1
var4d=false,
print_detail_grad=false,
/
&wrfvar2
/
&wrfvar3
ob_format=2,
/
&wrfvar4
/
&wrfvar5
/
&wrfvar6
max_ext_its=1,
ntmax=50,
orthonorm_gradient=true,
/
&wrfvar7
cv_options=5,
/
&wrfvar8
/
&wrfvar9
/
&wrfvar10
test_transforms=false,
test_gradient=false,
/
&wrfvar11
/
&wrfvar12
/
&wrfvar13
/
&wrfvar14
/
&wrfvar15
/
&wrfvar16
/
&wrfvar17
/
&wrfvar18
analysis_date="2008-02-05_12:00:00.0000",
/
&wrfvar19
/
&wrfvar20
/
&wrfvar21
time_window_min="2008-02-05_11:00:00.0000",
/
&wrfvar22
time_window_max="2008-02-05_13:00:00.0000",
/
&wrfvar23
/
&time_control
start_year=2008,
start_month=02,
start_day=05,
start_hour=12,
```

---

```
end_year=2008,
end_month=02,
end_day=05,
end_hour=12,
/
&fdda
/
&domains
e_we=90,
e_sn=60,
e_vert=41,
dx=60000,
dy=60000,
/
&dfi_control
/
&tc
/
&physics
mp_physics=3,
ra_lw_physics=1,
ra_sw_physics=1,
radt=60,
sf_sfclay_physics=1,
sf_surface_physics=1,
bl_pbl_physics=1,
cu_physics=1,
cudt=5,
num_soil_layers=5,
mp_zero_out=2,
co2tf=0,
/
&scm
/
&dynamics
/
&bdy_control
/
&grib2
/
&fire
/
&namelist_quilt
/
&perturbation
/
```

No edits should be needed if you are running the tutorial case without radiance data. If you plan to use the PREPBUFR-format data, change the `ob_format=1` in `&wrfvar3` in `namelist.input` and link the data as `ob.bufr`,

```
> ln -fs $DAT_DIR/ob/2008020512/gds1.t12.prepbufr.nr ob.bufr
```

Once you have changed any other necessary namelist variables, run WRFDA 3D-Var:

```
> da_wrfvar.exe >&! wrfda.log
```

The file `wrfda.log` (or `rsl.out.0000`, if run in distributed-memory mode) contains important WRFDA runtime log information. Always check the log after a WRFDA run:

```

*** VARIATIONAL ANALYSIS ***
DYNAMICS OPTION: Eulerian Mass Coordinate
 alloc_space_field: domain 1, 606309816 bytes allocat
ed
WRF TILE 1 IS 1 IE 89 JS 1 JE 59
WRF NUMBER OF TILES = 1
Set up observations (ob)

Using ASCII format observation input

scan obs ascii
end scan obs ascii
Observation summary
 ob time 1
 sound 86 global, 86 local
 synop 757 global, 750 local
 pilot 85 global, 85 local
 satem 106 global, 105 local
 geoamv 2556 global, 2499 local
 polaramv 0 global, 0 local
 airep 224 global, 221 local
 gpspw 187 global, 187 local
 gpsrf 3 global, 3 local
 metar 2416 global, 2408 local
 ships 145 global, 140 local
 ssmi_rv 0 global, 0 local
 ssmi_tb 0 global, 0 local
 ssmt1 0 global, 0 local
 ssmt2 0 global, 0 local
 qscat 2190 global, 2126 local
 profiler 61 global, 61 local
 buoy 247 global, 247 local
 bogus 0 global, 0 local
 pseudo 0 global, 0 local
 radar 0 global, 0 local
 radiance 0 global, 0 local
 airs_retrieval 0 global, 0 local
 sonde_sfc 86 global, 86 local
 mtgirs 0 global, 0 local
 tamdar 0 global, 0 local

Set up background errors for regional application for cv_options = 5

Using the averaged regression coefficients for unbalanced part

WRF-Var dry control variables are:psi, chi_u, t_u and ps_u
Humidity control variable is rh

Vertical truncation for psi = 15(99.00%)
Vertical truncation for chi_u = 20(99.00%)
Vertical truncation for t_u = 29(99.00%)
Vertical truncation for rh = 22(99.00%)

Scaling: var, len, ds: 0.100000E+01 0.100000E+01 0.600000E+05
Scaling: var, len, ds: 0.100000E+01 0.100000E+01 0.600000E+05
Scaling: var, len, ds: 0.100000E+01 0.100000E+01 0.600000E+05
Scaling: var, len, ds: 0.100000E+01 0.100000E+01 0.600000E+05
Scaling: var, len, ds: 0.100000E+01 0.100000E+01 0.600000E+05
Calculate innovation vector(iv)

Minimize cost function using CG method

Starting outer iteration : 1

```

Starting cost function: 2.53214888D+04, Gradient= 2.90675545D+02  
 For this outer iteration gradient target is: 2.90675545D+00

```

```

| Iter | Cost Function  | Gradient       | Step           |
|------|----------------|----------------|----------------|
| 1    | 2.32498037D+04 | 2.55571188D+02 | 4.90384516D-02 |
| 2    | 2.14988144D+04 | 2.22354203D+02 | 5.36154186D-02 |
| 3    | 2.01389088D+04 | 1.62537907D+02 | 5.50108123D-02 |
| 4    | 1.93433827D+04 | 1.26984567D+02 | 6.02247687D-02 |
| 5    | 1.88877194D+04 | 9.84565874D+01 | 5.65160951D-02 |
| 6    | 1.86297777D+04 | 7.49071361D+01 | 5.32184146D-02 |
| 7    | 1.84886755D+04 | 5.41516421D+01 | 5.02941363D-02 |
| 8    | 1.84118462D+04 | 4.68329312D+01 | 5.24003071D-02 |
| 9    | 1.83485166D+04 | 3.53595537D+01 | 5.77476335D-02 |
| 10   | 1.83191278D+04 | 2.64947070D+01 | 4.70109040D-02 |
| 11   | 1.82984221D+04 | 2.06996271D+01 | 5.89930206D-02 |
| 12   | 1.82875693D+04 | 1.56426527D+01 | 5.06578447D-02 |
| 13   | 1.82807224D+04 | 1.15892153D+01 | 5.59631997D-02 |
| 14   | 1.82773339D+04 | 8.74778514D+00 | 5.04582959D-02 |
| 15   | 1.82751663D+04 | 7.22150257D+00 | 5.66521675D-02 |
| 16   | 1.82736284D+04 | 4.81374868D+00 | 5.89786400D-02 |
| 17   | 1.82728636D+04 | 3.82286871D+00 | 6.60104384D-02 |
| 18   | 1.82724306D+04 | 3.16737517D+00 | 5.92526480D-02 |
| 19   | 1.82721735D+04 | 2.23392283D+00 | 5.12604438D-02 |

```

```

Inner iteration stopped after 19 iterations

Final: 19 iter, J= 1.98187399D+04, g= 2.23392283D+00

-----

Diagnostics

```
Final cost function J = 19818.74

Total number of obs. = 39800
Final value of J = 19818.73988
Final value of Jo = 16859.85861
Final value of Jb = 2958.88127
Final value of Jc = 0.00000
Final value of Je = 0.00000
Final value of Jp = 0.00000
Final value of Jl = 0.00000
Final J / total num_obs = 0.49796
Jb factor used(1) = 1.00000 1.00000 1.00000
1.00000 1.00000
 1.00000 1.00000 1.00000 1.00000 1.00000
Jb factor used(2) = 1.00000 1.00000 1.00000
1.00000 1.00000
 1.00000 1.00000 1.00000 1.00000 1.00000
Jb factor used(3) = 1.00000 1.00000 1.00000
1.00000 1.00000
 1.00000 1.00000 1.00000 1.00000 1.00000
Jb factor used(4) = 1.00000 1.00000 1.00000
1.00000 1.00000
 1.00000 1.00000 1.00000 1.00000 1.00000
Jb factor used(5) = 1.00000 1.00000 1.00000
1.00000 1.00000
 1.00000 1.00000 1.00000 1.00000 1.00000
Jb factor used = 1.00000
Je factor used = 1.00000
VarBC factor used = 1.00000
```

\*\*\* WRF-Var completed successfully \*\*\*

The file namelist.output.da (which contains the complete namelist settings) will be generated after a successful run of da\_wrfvar.exe. The settings appearing in

---

`namelist.output.da`, but not specified in your `namelist.input`, are the default values from `$WRFDA_DIR/Registry/Registry.wrfvar`.

After successful completion, `wrfvar_output` (the WRFDA analysis file, i.e. the new initial condition for WRF) should appear in the working directory along with a number of diagnostic files. Text files containing various diagnostics will be explained in the next section ([WRFDA Diagnostics](#)).

To understand the role of various important WRFDA options, try re-running WRFDA by changing different namelist options. For example, try making the WRFDA convergence criterion more stringent. This is achieved by reducing the value of “EPS” to e.g. 0.0001 by adding `"EPS=0.0001"` in the `namelist.input` record `&wrfvar6`. See the section ([WRFDA additional exercises](#)) for more namelist options.

### c. Run the Case—4D-Var

To run WRF 4D-Var, first create and enter a working directory, such as `$WRFDA_DIR/workdir`. Set the `WORK_DIR` environment variable (e.g. `setenv WORK_DIR $WRFDA_DIR/workdir`)

For the tutorial case, the analysis date is 2008020512 and the test data directories are:

```
> setenv DAT_DIR {directory where data is stored}
> ls -lr $DAT_DIR
ob/2008020512
ob/2008020513
ob/2008020514
ob/2008020515
ob/2008020516
ob/2008020517
ob/2008020518
rc/2008020512
be
```

**Note:** WRFDA 4D-Var is able to assimilate conventional observational data, satellite radiance BUFR data, radar data, and precipitation data. The input data format can be PREPBUFR format data or observation data, processed by OBSPROC.

Now follow the steps below:

#### 1) Link the executable file

```
> cd $WORK_DIR
> ln -fs $WRFDA_DIR/var/da/da_wrfvar.exe .
```

#### 2) Link the observational data, first guess, BE and LANDUSE.TBL, etc.

```
> ln -fs $DAT_DIR/ob/2008020512/ob.ascii+ ob01.ascii
```

---

```

> ln -fs $DAT_DIR/ob/2008020513/ob.ascii ob02.ascii
> ln -fs $DAT_DIR/ob/2008020514/ob.ascii ob03.ascii
> ln -fs $DAT_DIR/ob/2008020515/ob.ascii ob04.ascii
> ln -fs $DAT_DIR/ob/2008020516/ob.ascii ob05.ascii
> ln -fs $DAT_DIR/ob/2008020517/ob.ascii ob06.ascii
> ln -fs $DAT_DIR/ob/2008020518/ob.ascii- ob07.ascii

> ln -fs $DAT_DIR/rc/2008020512/wrfinput_d01 .
> ln -fs $DAT_DIR/rc/2008020512/wrfbdy_d01 .
> ln -fs wrfinput_d01 fg

> ln -fs $DAT_DIR/be/be.dat .
> ln -fs $WRFDA_DIR/run/LANDUSE.TBL .
> ln -fs $WRFDA_DIR/run/GENPARM.TBL .
> ln -fs $WRFDA_DIR/run/SOILPARM.TBL .
> ln -fs $WRFDA_DIR/run/VEGPARM.TBL .
> ln -fs $WRFDA_DIR/run/RRTM_DATA_DBL RTM_DATA

```

### 3) Copy the sample namelist

```
> cp $WRFDA_DIR/var/test/4dvar/namelist.input .
```

### 4) Edit necessary namelist variables, link optional files

Starting with V3.4, WRFDA 4D-Var has the capability to consider lateral boundary conditions as control variables as well during minimization. The namelist variable `var4d_lbc=true` turns on this capability. To enable this option, WRF 4D-Var needs not only the first guess at the beginning of the time window, but also the first guess at the end of the time window.

```
> ln -fs $DAT_DIR/rc/2008020518/wrfinput_d01 fg02
```

**Please note:** For WRFDA beginner, please don't use this option before you have a good understanding of the 4D-Var lateral boundary conditions control. To disable this feature, make sure `var4d_lbc` in `namelist.input` is set to `false`.

If you use PREPBUFR format data, set `ob_format=1` in `&wrfvar3` in `namelist.input`. Because 12UTC PREPBUFR data only includes the data from 9UTC to 15UTC, for 4D-Var you should include 18UTC PREPBUFR data as well:

```

> ln -fs $DAT_DIR/ob/2008020512/gds1.t12.prepbufr.nr ob01.bufr
> ln -fs $DAT_DIR/ob/2008020518/gds1.t18.prepbufr.nr ob02.bufr

```

**Note:** NCEP BUFR files downloaded from NCEP's public ftp server ([ftp://ftp.ncep.noaa.gov/pub/data/nccf/com/gfs/prod/gdas.\\${yyyymmddhh}](ftp://ftp.ncep.noaa.gov/pub/data/nccf/com/gfs/prod/gdas.${yyyymmddhh})) are Fortran-blocked on a big-endian machine and can be directly used on big-endian machines (for example, IBM). For most Linux clusters with Intel platforms, users need to download the byte-swapping code `ssrc.c` (<http://www.dtcenter.org/com-GSI/users/support/faqs/index.php>). The C code `ssrc.c` is located in the `/utils/bufr_tools` directory of the GSI distribution. This code will convert a `prepbufr` file generated on an IBM platform to a `prepbufr` file that can be read on a Linux or Intel Mac platform. Compile `ssrc.c` with any C compiler (e.g., `gcc -o ssrc.exe ssrc.c`).



To convert an IBM prepbufr file, take the executable (e.g. `ssrc.exe`), and run it as follows:

```
ssrc.exe <Big Endian prepbufr file> Little Endian prepbufr file
```

Edit `$WORK_DIR/namelist.input` to match your experiment settings. The most important namelist variables related to 4D-Var are listed below. Please refer to `README.namelist` under the `$WRFDA_DIR/var` directory. Common mistakes users make are in the time information settings. The rules are: `analysis_date`, `time_window_min` and `start_xxx` in `&time_control` should always be equal to each other; `time_window_max` and `end_xxx` should always be equal to each other; and `run_hours` is the difference between `start_xxx` and `end_xxx`, which is the length of the 4D-Var time window.

```
&wrfvar1
var4d=true,
var4d_lbc=false,
var4d_bin=3600,
.....
/
.....
&wrfvar18
analysis_date="2008-02-05_12:00:00.0000",
/
.....
&wrfvar21
time_window_min="2008-02-05_12:00:00.0000",
/
.....
&wrfvar22
time_window_max="2008-02-05_18:00:00.0000",
/
.....
&time_control
run_hours=6,
start_year=2008,
start_month=02,
start_day=05,
start_hour=12,
end_year=2008,
end_month=02,
end_day=05,
end_hour=18,
interval_seconds=21600,
debug_level=0,
/
.....
```

## 5) Run WRF 4D-Var

```
> cd $WORK_DIR
> ./da_wrfvar.exe >&! wrfda.log
```

Please note: If you utilize the lateral boundary conditions option (`var4d_lbc=true`), in addition to the analysis at the beginning of the time window (`wrfvar_output`), the analysis at the end of the time window will also be generated as `ana02`, which will be used in

subsequent updating of boundary conditions before the forecast.

## Radiance Data Assimilation in WRFDA

This section gives a brief description for various aspects related to radiance assimilation in WRFDA. Each aspect is described mainly from the viewpoint of usage, rather than more technical and scientific details, which will appear in a separate technical report and scientific paper. Namelist parameters controlling different aspects of radiance assimilation will be detailed in the following sections. It should be noted that this section does not cover general aspects of the assimilation process with WRFDA; these can be found in other sections of chapter 6 of this user's guide, or other WRFDA documentation.

### a. Running WRFDA with radiances

In addition to the basic input files (`LANDUSE.TBL`, `fg`, `ob.ascii`, `be.dat`) mentioned in the "[Running WRFDA](#)" section, the following additional files are required for radiances: radiance data in NCEP BUFR format, `radiance_info` files, `VARBC.in`, and RTM (`CRTM` or `RTTOV`) coefficient files.

Edit `namelist.input` (Pay special attention to `&wrfvar4`, `&wrfvar14`, `&wrfvar21`, and `&wrfvar22` for radiance-related options. A very basic `namelist.input` for running the radiance test case is provided in `WRFDA/var/test/radiance/namelist.input`)

```
> ln -sf $DAT_DIR/gdas1.t00z.1bamua.tm00.bufr_d ./amsua.bufr
> ln -sf $DAT_DIR/gdas1.t00z.1bamub.tm00.bufr_d ./amsub.bufr
> ln -sf $WRFDA_DIR/var/run/radiance_info ./radiance_info # (radi-
ance_info is a directory)
> ln -sf $WRFDA_DIR/var/run/VARBC.in ./VARBC.in
(CRTM only) > ln -sf WRFDA/var/run/crtm_coeffs ./crtm_coeffs
#(crtm_coeffs is a directory)
(RTTOV only) > ln -sf your_RTTOV_path/rtcoef_rttov10/rttov7pred51L
./rttov_coeffs # (rttov_coeffs is a directory)
```

See the following sections for more details on each aspect of radiance assimilation.

### b. Radiance Data Ingest

Currently, the ingest interface for NCEP BUFR radiance data is implemented in WRFDA. The radiance data are available through NCEP's public ftp server ([ftp://ftp.ncep.noaa.gov/pub/data/nccf/com/gfs/prod/gdas.\\${yyyymmddhh}](ftp://ftp.ncep.noaa.gov/pub/data/nccf/com/gfs/prod/gdas.${yyyymmddhh})) in near real-time (with a 6-hour delay) and can meet requirements for both research purposes and some real-time applications.

As of Version 3.4, WRFDA can read data from the NOAA ATOVS instruments (HIRS,

AMSU-A, AMSU-B and MHS), the EOS Aqua instruments (AIRS, AMSU-A) and DMSP instruments (SSMIS). Note that NCEP radiance BUFR files are separated by instrument names (i.e., one file for each type of instrument), and each file contains global radiance (generally converted to brightness temperature) within a 6-hour assimilation window, from multi-platforms. For running WRFDA, users need to rename NCEP corresponding BUFR files (table 1) to `hirs3.bufr` (including HIRS data from NOAA-15/16/17), `hirs4.bufr` (including HIRS data from NOAA-18/19, METOP-2), `amsua.bufr` (including AMSU-A data from NOAA-15/16/18/19, METOP-2), `amsub.bufr` (including AMSU-B data from NOAA-15/16/17), `mhs.bufr` (including MHS data from NOAA-18/19 and METOP-2), `airs.bufr` (including AIRS and AMSU-A data from EOS-AQUA) `ssmis.bufr` (SSMIS data from DMSP-16, AFWA provided) and `iasi.bufr` (IASI data from Metop-2) for WRFDA filename convention. Note that the `airs.bufr` file contains not only AIRS data but also AMSU-A, which is collocated with AIRS pixels (1 AMSU-A pixel collocated with 9 AIRS pixels). Users must place these files in the working directory where the WRFDA executable is run. It should also be mentioned that WRFDA reads these BUFR radiance files directly without the use of any separate pre-processing program. All processing of radiance data, such as quality control, thinning, bias correction, etc., is carried out within WRFDA. This is different from conventional observation assimilation, which requires a pre-processing package (OBSPROC) to generate WRFDA readable ASCII files. For reading the radiance BUFR files, WRFDA must be compiled with the NCEP BUFR library (see <http://www.nco.ncep.noaa.gov/sib/decoders/BUFRLIB/>).

Table 1: NCEP and WRFDA radiance BUFR file naming convention

| NCEP BUFR file names                        | WRFDA naming convention |
|---------------------------------------------|-------------------------|
| <code>gdas1.t00z.1bamua.tm00.bufr_d</code>  | <code>amsua.bufr</code> |
| <code>gdas1.t00z.1bamub.tm00.bufr_d</code>  | <code>amsub.bufr</code> |
| <code>gdas1.t00z.1bhirs3.tm00.bufr_d</code> | <code>hirs3.bufr</code> |
| <code>gdas1.t00z.1bhirs4.tm00.bufr_d</code> | <code>hirs4.bufr</code> |
| <code>gdas1.t00z.1bmhs.tm00.bufr_d</code>   | <code>mhs.bufr</code>   |
| <code>gdas1.t00z.airsev.tm00.bufr_d</code>  | <code>airs.bufr</code>  |
| <code>gdas1.t00z.mtiasi.tm00.bufr_d</code>  | <code>iasi.bufr</code>  |

Namelist parameters are used to control the reading of corresponding BUFR files into WRFDA. For instance, `USE_AMSUAOBS`, `USE_AMSUBOBS`, `USE_HIRS3OBS`, `USE_HIRS4OBS`, `USE_MHSOBS`, `USE_AIRSOBS`, `USE_EOS_AMSUAOBS` and `USE_SSMISOBS` and `USE_IASIOBS` control whether or not the respective file is read. These are logical parameters that are assigned to `.FALSE.` by default; therefore they must be set to `.TRUE.` to read the respective observation file. Also note that these parameters only control whether the data is read, not whether the data included in the files is to be assimilated. This is controlled by other namelist parameters explained in the next section.

NCEP BUFR files downloaded from NCEP's public ftp server ([ftp://ftp.ncep.noaa.gov/pub/data/nccf/com/gfs/prod/gdas.\\${yyyymmddhh}](ftp://ftp.ncep.noaa.gov/pub/data/nccf/com/gfs/prod/gdas.${yyyymmddhh})) are Fortran-blocked on a big-endian machine and can be directly used on big-endian machines (for

example, IBM). For most Linux clusters with Intel platforms, users need to download the byte-swapping code `ssrc.c` (<http://www.dtcenter.org/com-GSI/users/support/faqs/index.php>). The C code `ssrc.c` is located in the `/utils` directory of the GSI distribution, and will convert a PREPBUFR file generated on an IBM platform to a PREPBUFR file that can be read on a Linux or Intel Mac platform. Compile `ssrc.c` with any C compiler (e.g., `gcc -o ssrc.exe ssrc.c`). To convert an IBM PREPBUFR file, take the executable (e.g. `ssrc.exe`), and run it as follows:

```
ssrc.exe < Big Endian prepbufr file> Little Endian prepbufr file
```

### c. Radiative Transfer Model

The core component for direct radiance assimilation is to incorporate a radiative transfer model (RTM) into the WRFDA system as one part of observation operators. Two widely used RTMs in the NWP community, RTTOV (developed by ECMWF and UKMET in Europe), and CRTM (developed by the Joint Center for Satellite Data Assimilation (JCSDA) in US), are already implemented in the WRFDA system with a flexible and consistent user interface. WRFDA is designed to be able to compile with any combination of the two RTM libraries, or without RTM libraries (for those not interested in radiance assimilation), by the definition of environment variables “CRTM” and “RTTOV” (see the “Installing WRFDA” section). Note, however, that at runtime the user must select one of the two or neither, via the namelist parameter `RTM_OPTION` (1 for RTTOV, the default, and 2 for CRTM).

Both RTMs can calculate radiances for almost all available instruments aboard the various satellite platforms in orbit. An important feature of the WRFDA design is that all data structures related to radiance assimilation are dynamically allocated during running time, according to a simple namelist setup. The instruments to be assimilated are controlled at run-time by four integer namelist parameters: `RTMINIT_NSENSOR` (the total number of sensors to be assimilated), `RTMINIT_PLATFORM` (the platforms IDs array to be assimilated with dimension `RTMINIT_NSENSOR`, e.g., 1 for NOAA, 9 for EOS, 10 for METOP and 2 for DMSP), `RTMINIT_SATID` (satellite IDs array) and `RTMINIT_SENSOR` (sensor IDs array, e.g., 0 for HIRS, 3 for AMSU-A, 4 for AMSU-B, 15 for MHS, 10 for SSMIS, 11 for AIRS, 16 for IASI). An example configuration for assimilating 14 of the sensors from 7 satellites is listed here:

```
RTMINIT_NSENSOR = 15 # 6 AMSUA; 3 AMSUB; 3 MHS; 1 AIRS; 1 SSMIS; 1 IASI
RTMINIT_PLATFORM = 1, 1, 1, 1, 9, 10, 1, 1, 1, 1, 1, 10, 9, 2, 10,
RTMINIT_SATID = 15, 16, 18, 19, 2, 2, 15, 16, 17, 18, 19, 2, 2, 16, 2
RTMINIT_SENSOR = 3, 3, 3, 3, 3, 3, 4, 4, 4, 15, 15, 15, 11, 10, 16,
```

The instrument triplets (platform, satellite, and sensor ID) in the namelist can be ranked in any order. More detail about the convention of instrument triples can be found on the web page [http://research.metoffice.gov.uk/research/interproj/nwpsaf/rtm/rttov\\_description.html](http://research.metoffice.gov.uk/research/interproj/nwpsaf/rtm/rttov_description.html) or in tables 2 and 3 in the RTTOV v10 User’s Guide

([research.metoffice.gov.uk/research/interproj/nwpsaf/rtm/docs\\_rttov10/users\\_guide\\_10\\_v1.5.pdf](http://research.metoffice.gov.uk/research/interproj/nwpsaf/rtm/docs_rttov10/users_guide_10_v1.5.pdf))

CRTM uses a different instrument-naming method, however, a conversion routine inside WRFDA is implemented such that the user interface remains the same for RTTOV and CRTM, using the same instrument triplet for both.

When running WRFDA with radiance assimilation switched on, a set of RTM coefficient files need to be loaded. For the RTTOV option, RTTOV coefficient files are to be copied or linked to a sub-directory `rttov_coeffs/` under the working directory. For the CRTM option, CRTM coefficient files are to be copied or linked to a sub-directory `crtm_coeffs/` under the working directory. Only coefficients listed in the namelist are needed. Potentially WRFDA can assimilate all sensors as long as the corresponding coefficient files are provided. In addition, necessary developments on the corresponding data interface, quality control, and bias correction are important to make radiance data assimilate properly; however, a modular design of radiance relevant routines already facilitates the addition of more instruments in WRFDA.

The RTTOV package is not distributed with WRFDA, due to licensing and supporting issues. Users need to follow the instructions at <http://research.metoffice.gov.uk/research/interproj/nwpsaf/rtm> to download the RTTOV source code and supplement coefficient files and the emissivity atlas dataset. Starting with version 3.3, only RTTOV v10 can be used in WRFDA.

Since V3.2.1, the CRTM package is distributed with WRFDA, which is located in `$WRFDA_DIR/var/external/crtm`. The CRTM code in WRFDA is basically the same as the source code that users can download from <ftp://ftp.emc.ncep.noaa.gov/jcsda/CRTM>.

#### d. Channel Selection

Channel selection in WRFDA is controlled by radiance ‘info’ files, located in the sub-directory `radiance_info`, under the working directory. These files are separated by satellites and sensors; e.g., `noaa-15-amsua.info`, `noaa-16-amsub.info`, `dmsp-16-ssmis.info` and so on. An example of 5 channels from `noaa-15-amsub.info` is shown below. The fourth column is used by WRFDA to control when to use a corresponding channel. Channels with the value “-1” in the fourth column indicate that the channel is “not assimilated,” while the value “1” means “assimilated.” The sixth column is used by WRFDA to set the observation error for each channel. Other columns are not used by WRFDA. It should be mentioned that these error values might not necessarily be optimal for your applications. It is the user’s responsibility to obtain the optimal error statistics for his/her own applications.

| Sensor channel | IR/MW | use | idum | varch | polarization<br>(0:vertical;1:horizontal) |                  |
|----------------|-------|-----|------|-------|-------------------------------------------|------------------|
| 415            | 1     | 1   | -1   | 0     | 0.5500000000E+01                          | 0.0000000000E+00 |
| 415            | 2     | 1   | -1   | 0     | 0.3750000000E+01                          | 0.0000000000E+00 |
| 415            | 3     | 1   | 1    | 0     | 0.3500000000E+01                          | 0.0000000000E+00 |
| 415            | 4     | 1   | -1   | 0     | 0.3200000000E+01                          | 0.0000000000E+00 |

---

415 5 1 1 0 0.2500000000E+01 0.0000000000E+00

## e. Bias Correction

Satellite radiance is generally considered to be biased with respect to a reference (e.g., background or analysis field in NWP assimilation) due to systematic error of the observation itself, the reference field, and RTM. Bias correction is a necessary step prior to assimilating radiance data. There are two ways of performing bias correction in WRFDA. One is based on the Harris and Kelly (2001) method, and is carried out using a set of coefficient files pre-calculated with an off-line statistics package, which was applied to a training dataset for a month-long period. The other is Variational Bias Correction (VarBC). Only VarBC is introduced here, and recommended for users because of its relative simplicity in usage.

## f. Variational Bias Correction

### Getting started with VarBC

To use VarBC, set the namelist option `USE_VARBC` to TRUE and have the `VARBC.in` file in the working directory. `VARBC.in` is a VarBC setup file in ASCII format. A template is provided with the WRFDA package (`$WRFDA_DIR/var/run/VARBC.in`).

### Input and Output files

All VarBC input is passed through a single ASCII file called `VARBC.in`. Once WRFDA has run with the VarBC option switched on, it will produce a `VARBC.out` file in a similar ASCII format. This output file will then be used as the input file for the next assimilation cycle.

### Coldstart

Coldstarting means starting the VarBC from scratch; i.e. when you do not know the values of the bias parameters.

The Coldstart is a routine in WRFDA. The bias predictor statistics (mean and standard deviation) are computed automatically and will be used to normalize the bias parameters. All coldstart bias parameters are set to zero, except the first bias parameter (= simple offset), which is set to the mode (=peak) of the distribution of the (uncorrected) innovations for the given channel.

A threshold of a number of observations can be set through the namelist option `VARBC_NOBSMIN` (default = 10), under which it is considered that not enough observations are present to keep the Coldstart values (i.e. bias predictor statistics and bias parameter values) for the next cycle. In this case, the next cycle will do another Coldstart.

### Background Constraint for the bias parameters

The background constraint controls the inertia you want to impose on the predictors (i.e.

the smoothing in the predictor time series). It corresponds to an extra term in the WRFDA cost function.

It is defined through an integer number in the `VARBC.in` file. This number is related to a number of observations; the bigger the number, the more inertia constraint. If these numbers are set to zero, the predictors can evolve without any constraint.

### Scaling factor

The VarBC uses a specific preconditioning, which can be scaled through the namelist option `VARBC_FACTOR` (default = 1.0).

### Offline bias correction

The analysis of the VarBC parameters can be performed "offline" ; i.e. independently from the main WRFDA analysis. No extra code is needed. Just set the following `MAX_VERT_VAR*` namelist variables to be 0, which will disable the standard control variable and only keep the VarBC control variable.

```
MAX_VERT_VAR1=0.0
MAX_VERT_VAR2=0.0
MAX_VERT_VAR3=0.0
MAX_VERT_VAR4=0.0
MAX_VERT_VAR5=0.0
```

### Freeze VarBC

In certain circumstances, you might want to keep the VarBC bias parameters constant in time ("frozen"). In this case, the bias correction is read and applied to the innovations, but it is not updated during the minimization. This can easily be achieved by setting the namelist options:

```
USE_VARBC=false
FREEZE_VARBC=true
```

### Passive observations

Some observations are useful for preprocessing (e.g. Quality Control, Cloud detection) but you might not want to assimilate them. If you still need to estimate their bias correction, these observations need to go through the VarBC code in the minimization. For this purpose, the VarBC uses a separate threshold on the QC values, called "qc\_varbc\_bad". This threshold is currently set to the same value as "qc\_bad", but can easily be changed to any ad hoc value.

## g. Other namelist variables to control radiance assimilation

### `RAD_MONITORING` (30)

Integer array of dimension `RTMINIT_NSENER`, 0 for assimilating mode, 1 for



monitoring mode (only calculates innovation).

**THINNING**

Logical, TRUE will perform thinning on radiance data.

**THINNING\_MESH (30)**

Real array with dimension RTMINIT\_NSENSOR, values indicate thinning mesh (in km) for different sensors.

**QC\_RAD**

Logical, controls if quality control is performed, always set to TRUE.

**WRITE\_IV\_RAD\_ASCII**

Logical, controls whether to output observation-minus-background (O-B) files, which are in ASCII format, and separated by sensors and processors.

**WRITE\_OA\_RAD\_ASCII**

Logical, controls whether to output observation-minus-analysis (O-A) files (including also O-B information), which are in ASCII format, and separated by sensors and processors.

**USE\_ERROR\_FACTOR\_RAD**

Logical, controls use of a radiance error tuning factor file (`radiance_error.factor`) which is created with empirical values, or generated using a variational tuning method (Desroziers and Ivanov, 2001).

**ONLY\_SEA\_RAD**

Logical, controls whether only assimilating radiance over water.

**TIME\_WINDOW\_MIN**

String, e.g., "2007-08-15\_03:00:00.0000", start time of assimilation time window

**TIME\_WINDOW\_MAX**

String, e.g., "2007-08-15\_09:00:00.0000", end time of assimilation time window

**USE\_ANTCORR (30)**

Logical array with dimension RTMINIT\_NSENER, controls if performing Antenna Correction in CRTM.

**USE\_CLDDET\_MMR**

Logical, controls whether using the MMR scheme to conduct cloud detection for infrared radiance.

**USE\_CLDDET\_ECMWF**

---

Logical, controls whether using the ECMWF scheme to conduct cloud detection for infrared radiance.

**AIRS\_WARMEST\_FOV**

Logical, controls whether using the observation brightness temperature for AIRS Window channel #914 as criterium for GSI thinning.

**USE\_CRTM\_KMATRIX**

Logical, controls whether using the CRTM K matrix rather than calling CRTM TL and AD routines for gradient calculation.

**USE\_RTTOV\_KMATRIX**

Logical, controls whether using the RTTOV K matrix rather than calling RTTOV TL and AD routines for gradient calculation.

**RTTOV\_EMIS\_ATLAS\_IR**

Integer, controls the use of the IR emissivity atlas. Emissivity atlas data (should be downloaded separately from the RTTOV web site) need to be copied or linked under a sub-directory of the working directory (`emis_data`) if `RTTOV_EMIS_ATLAS_IR` is set to 1.

**RTTOV\_EMIS\_ATLAS\_MW**

Integer, controls the use of the MW emissivity atlas. Emissivity atlas data (should be downloaded separately from the RTTOV web site) need to be copied or linked under a sub-directory of the working directory (`emis_data`) if `RTTOV_EMIS_ATLAS_MW` is set to 1 or 2.

## **h. Diagnostics and Monitoring**

### (1) Monitoring capability within WRFDA

Run WRFDA with the `rad_monitoring` namelist parameter in record `wrfvar14` in `namelist.input`.

0 means assimilating mode. Innovations (O minus B) are calculated and data are used in minimization.

1 means monitoring mode: innovations are calculated for diagnostics and monitoring. Data are not used in minimization.

The value of `rad_monitoring` should correspond to the value of `rtminit_nsensor`. If `rad_monitoring` is not set, then the default value of 0 will be used for all sensors.

### (2) Outputting radiance diagnostics from WRFDA

---

Run WRFDA with the following namelist options in record `wrfvar14` in `namelist.input`.

**write\_iv\_rad\_ascii**

Logical. TRUE to write out (observation-background, etc.) diagnostics information in plain-text files with the prefix 'inv,' followed by the instrument name and the processor id. For example, `01_inv_noaa-17-amsub.0000` (01 is outerloop index, 0000 is processor index)

**write\_oa\_rad\_ascii**

Logical. TRUE to write out (observation-background, observation-analysis, etc.) diagnostics information in plain-text files with the prefix 'oma,' followed by the instrument name and the processor id. For example, `01_oma_noaa-18-mhs.0001`

Each processor writes out the information for one instrument in one file in the WRFDA working directory.

**(3) Radiance diagnostics data processing**

A Fortran90 program is used to collect the `01_inv*` or `01_oma*` files and write them out in netCDF format (one instrument in one file with prefix `diags` followed by the instrument name, analysis date, and the suffix `.nc`) for easier data viewing, handling and plotting with netCDF utilities and NCL scripts.

**(4) Radiance diagnostics plotting**

Two NCL scripts (available as part of the WRFDA Tools package, which can be downloaded at <http://www.mmm.ucar.edu/wrf/users/wrfda/download/tools.html>) are used for plotting: `$TOOLS_DIR/var/graphics/ncl/plot_rad_diags.ncl` and `$TOOLS_DIR/var/graphics/ncl/advance_cymdh.ncl`. The NCL scripts can be run from a shell script, or run alone with an interactive `ncl` command (the NCL script and set the plot options must be edited, and the path of `advance_cymdh.ncl`, a date-advancing script loaded in the main NCL plotting script, may need to be modified).

Steps (3) and (4) can be done by running a single `ksh` script (also in the WRFDA Tools package: `$TOOLS_DIR/var/scripts/da_rad_diags.ksh`) with proper settings. In addition to the settings of directories and what instruments to plot, there are some useful plotting options, explained below.

|                                           |                                                                                                                                                                                                 |
|-------------------------------------------|-------------------------------------------------------------------------------------------------------------------------------------------------------------------------------------------------|
| <code>setenv OUT_TYPE=ncgm</code>         | <code>ncgm</code> or <code>pdf</code><br>pdf will be much slower than <code>ncgm</code> and generate huge output if plots are not split. But pdf has higher resolution than <code>ncgm</code> . |
| <code>setenv PLOT_STATS_ONLY=false</code> | true or false                                                                                                                                                                                   |

---

|                                        |                                                                                                                                                                                                                                              |
|----------------------------------------|----------------------------------------------------------------------------------------------------------------------------------------------------------------------------------------------------------------------------------------------|
| <code>setenv PLOT_OPT=sea_only</code>  | true: only statistics of OMB/OMA vs channels and OMB/OMA vs dates will be plotted.<br>false: data coverage, scatter plots (before and after bias correction), histograms (before and after bias correction), and statistics will be plotted. |
| <code>setenv PLOT_QCED=false</code>    | all, sea_only, land_only<br>true or false<br>true: plot only quality-controlled data<br>false: plot all data                                                                                                                                 |
| <code>setenv PLOT_HISTO=false</code>   | true or false: switch for histogram plots                                                                                                                                                                                                    |
| <code>setenv PLOT_SCATT=true</code>    | true or false: switch for scatter plots                                                                                                                                                                                                      |
| <code>setenv PLOT_EMISS=false</code>   | true or false: switch for emissivity plots                                                                                                                                                                                                   |
| <code>setenv PLOT_SPLIT=false</code>   | true or false<br>true: one frame in each file<br>false: all frames in one file                                                                                                                                                               |
| <code>setenv PLOT_CLOUDY=false</code>  | true or false<br>true: plot cloudy data. Cloudy data to be plotted are defined by PLOT_CLOUDY_OPT (si or clwp), CLWP_VALUE, SI_VALUE settings.                                                                                               |
| <code>setenv PLOT_CLOUDY_OPT=si</code> | si or clwp<br>clwp: cloud liquid water path from model<br>si: scatter index from obs, for amsua, amsub and mhs only                                                                                                                          |
| <code>setenv CLWP_VALUE=0.2</code>     | only plot points with<br>clwp >= clwp_value (when clwp_value > 0)<br>clwp > clwp_value (when clwp_value = 0)                                                                                                                                 |
| <code>setenv SI_VALUE=3.0</code>       |                                                                                                                                                                                                                                              |

### (5) Evolution of VarBC parameters

NCL scripts (also in the WRFDA Tools package:

`$TOOLS_DIR/var/graphics/ncl/plot_rad_varbc_param.ncl` and

`$TOOLS_DIR/var/graphics/ncl/advance_cymdh.ncl`) are used for plotting the evolution of VarBC parameters.

## Precipitation Data Assimilation in WRFDA 4D-Var

The assimilation of precipitation observations in WRFDA 4D-Var is described in this section. Currently, WRFPLUS has already included the adjoint and tangent linear codes of large-scale condensation and cumulus scheme, therefore precipitation data can be assimilated directly in 4D-Var. Users who are interested in the scientific detail of 4D-Var assimilation of precipitation should refer to related scientific papers, as this section is only a basic guide to running WRFDA Precipitation Assimilation. This section instructs us-

ers on data processing, namelist variable settings, and how to run WRFDA 4D-Var with precipitation observations.

### a. Prepare precipitation observations for 4D-Var

As of version 3.4, WRFDA 4D-Var can assimilate NCEP Stage IV radar and gauge precipitation data. NCEP Stage IV archived data are available on the NCAR CODIAC web page at: <http://data.eol.ucar.edu/codiac/dss/id=21.093> (for more information, please see the NCEP Stage IV Q&A Web page at <http://www.emc.ncep.noaa.gov/mmb/ylin/pcpanl/QandA/>). The original precipitation data are at 4-km resolution on a polar-stereographic grid. Hourly, 6-hourly and 24-hourly analyses are available. The following image shows the accumulated 6-h precipitation for the tutorial case.

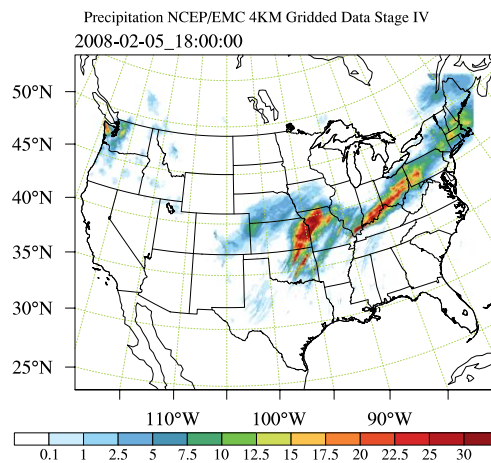

It should be mentioned that the NCEP Stage IV archived data is in GRIB1 format and it cannot be ingested into the WRFDA directly. A tool “CONVERTER” is provided to reformat GRIB1 observations into the WRFDA-readable ASCII format. It can be downloaded from the WRFDA users page at <http://www.mmm.ucar.edu/wrf/users/wrfda/download/CONVERTER.gz>. The NCEP GRIB libraries, w3 and g2 are required to compile the CONVERTER. These libraries are available for download from NCEP at <http://www.nco.ncep.noaa.gov/pmb/codes/GRIB2/>. The output file to the CONVERTER is named in the format `ob.rain.yyyyymmddhh.xxh`; The 'yyyymmddhh' in the file name is the ending hour of the accumulation period, and 'xx' (=01,06 or 24) is the accumulating time period.

For users wishing to use their own observations instead of NCEP Stage IV, it is the user’s responsibility to write a Fortran main program and call subroutine `writerainobs` (in `write_rainobs.f90`) to generate their own precipitation data. For more information please refer to the README file in the `CONVERTER` directory.

### b. Running WRFDA 4D-Var with precipitation observations

WRFDA 4D-Var is able to assimilate hourly, 3-hourly and 6-hourly precipitation data. According to experiments and related scientific papers, 6-hour precipitation accumulations are the ideal observations to be assimilated, as this leads to better results than directly assimilating hourly data.

The tutorial example is for assimilating 6-hour accumulated precipitation. In your working directory, link all the necessary files as follows,

```
> ln -fs $WRFDA_DIR/var/da/da_wrfvar.exe .
> ln -fs $DAT_DIR/rc/2008020512/wrfinput_d01 .
> ln -fs $DAT_DIR/rc/2008020512/wrfbody_d01 .
> ln -fs wrfinput_d01 fg
> ln -fs $DAT_DIR/be/be.dat .
> ln -fs $WRFDA_DIR/run/LANDUSE.TBL ./LANDUSE.TBL
> ln -fs $DAT_DIR/ob/2008020518/ob.rain.2008020518.06h ob07.rain
```

Note: The reason why the observation `ob.rain.2008020518.06h` is linked as `ob07.rain` will be explained in section d.

Edit `namelist.input` and pay special attention to `&wrfvar1` and `&wrfvar4` for precipitation-related options.

```
&wrfvar1
var4d=true,
var4d_lbc=true,
var4d_bin=3600,
var4d_bin_rain=21600,
.....
/
.....
&wrfvar4
use_rainobs=true,
thin_rainobs=true,
thin_mesh_conv=30*20.,
/
```

Then, run 4D-Var in serial or parallel mode,

```
> ./da_wrfvar.exe >&! wrfda.log
```

### c. Namelist variables to control precipitation assimilation

#### **var4d\_bin\_rain**

Precipitation observation sub-window length for 4D-Var. It does not need to be consistent with `var4d_bin`.

#### **thin\_rainobs**

Logical, TRUE will perform thinning on precipitation data.

**thin\_mesh\_conv**

Specify thinning mesh size (in km)

**d. Properly linking observation files**

In section b, `ob.rain.2008020518.06h` is linked as `ob07.rain`. The number 07 is assigned according to the following rule:

$$x=i*(\text{var4d\_bin\_rain}/\text{var4d\_bin})+1,$$

Here,  $i$  is the sequence number of the observation.

for  $x < 10$ , the observation file should be renamed as `ob0x.rain`;

for  $x \geq 10$ , it should be renamed as `obx.rain`

In the example above, 6-hour accumulated precipitation data is assimilated in 6-hour time window. In the namelist, values should be set at `var4d_bin=3600` and `var4d_bin_rain=21600`, and there is one observation file (i.e.,  $i=1$ ) in the time window, Thus the value of  $x$  is 7. The file `ob.rain.2008020518.06h` should be renamed as `ob07.rain`.

Let us take another example for how to rename observation files for 3-hourly precipitation data in 6-hour time window. The sample namelist is as follows,

```
&wrfvar1
var4d=true,
var4d_lbc=true,
var4d_bin=3600,
var4d_bin_rain=10800,
.....
/
```

There are two observation files, `ob.rain.2008020515.03h` and `ob.rain.2008020518.03h`. For the first file ( $i=1$ ) `ob.rain.2008020515.03h`, it should be renamed as `ob04.rain`, and the second file ( $i=2$ ) renamed as `ob07.rain`.

**Updating WRF Boundary Conditions**

There are three input files: WRFDA analysis, `wrfinput`, and `wrfbdy` files from `WPS/real.exe`, and a namelist file: `parame.in` for running `da_update_bc.exe`



for domain-1. Before running an NWP forecast using the WRF-model with WRFDA analysis, update the values and tendencies for each predicted variable in the first time period, in the lateral boundary condition file. Domain-1 (`wrfbdy_d01`) must be updated to be consistent with the new WRFDA initial condition (analysis). This is absolutely essential. Moreover, in the cycling-run mode (warm-start), the lower boundary in the WRFDA analysis file also needs to be updated based on the information from the `wrfinput` file, generated by WPS/real.exe at analysis time.

For nested domains, domain-2, domain-3, etc., the lateral boundaries are provided by their parent domains, so no lateral boundary update is needed for these domains; but the low boundaries in each of the nested domains' WRFDA analysis files still need to be updated. In these cases, you must set the namelist variable, `domain_id > 1` (default is 1 for domain-1), and no `wrfbdy_d01` file needs to be provided to the namelist variable `wrf_bdy_file`.

This procedure is performed by the WRFDA utility called `da_update_bc.exe`, and is located in `$WRFDA_DIR/var/build`.

To run `da_update_bc.exe`, follow the steps below:

```
> cd $WRFDA_DIR/var/test/update_bc
> cp -p $DAT_DIR/rc/2008020512/wrfbdy_d01 .
 (IMPORTANT: make a copy of wrfbdy_d01, as the wrf_bdy_file will be over-
 written by da_update_bc.exe)
> vi parame.in
&control_param
da_file = './wrfvar_output'
da_file_02 = './ana02'
wrf_bdy_file = './wrfbdy_d01'
wrf_input = '$DAT_DIR/rc/2008020512/wrfinput_d01'
domain_id = 1
cycling = .false. (set to .true. if first guess comes from a previous WRF forecast.)
debug = .true.
low_bdy_only = .false.
update_lsm = .false.
var4d_lbc = .false.
/

> ln -sf $WRFDA_DIR/var/da/da_update_bc.exe .
> ./da_update_bc.exe
```

At this stage, you should have the files `wrfvar_output` and `wrfbdy_d01` in your WRFDA working directory. They are the WRFDA updated initial condition and boundary condition for any subsequent WRF model runs. To use, link a copy of `wrfvar_output` and `wrfbdy_d01` to `wrfinput_d01` and `wrfbdy_d01`, respectively, in your WRF working directory.

If you activate the `var4d_lbc` option in a WRF 4D-Var run, you should also copy/link

---

the `ana02` file from the WRFDA working directory to the `da_update_bc` working directory and set the `var4d_lbc` variable to `TRUE` in `parame.in`.

Starting with V3.2, some changes were made to `da_update_bc` to address some issues related to sea-ice and snow change during cycling runs, and radiance data assimilation. The new settings in `parame.in` are introduced as follows:

Note: for backward compatibility, the pre-V3.2 `parame.in`, mentioned above, still works with V3.2+ `da_update_bc`.

```
&control_param
da_file = '../tutorial/wrfvar_output'
da_file_02 = './ana02'
wrf_bdy_file = './wrfbdy_d01'
wrf_input = '$DAT_DIR/rc/2008020512/wrfinput_d01'
domain_id = 1
debug = .true.
update_lateral_bdy = .true.
update_low_bdy = .true.
update_lsm = .false.
iswater = 16
var4d_lbc = .false.
/
```

`update_lateral_bdy` is required only for domain 1.

`update_low_bdy` is needed for all domains if running in cycling mode.

`iswater` (water point index) is 16 for USGS LANDUSE and 17 for MODIS LANDUSE.

**If in cycling mode** (especially if you are doing radiance data assimilation and there are SEA ICE and SNOW in your domain), it is recommended that **before** you run WRFDA, you run `da_update_bc.exe` with the following namelist options:

```
update_lateral_bdy = .false.
update_low_bdy = .true.
```

This creates a lower-boundary **updated** first guess (`da_file` will be overwritten by `da_update_bc`). Then, after WRFDA has finished, run `da_update_bc.exe` again with the following namelist options:

```
update_lateral_bdy = .true.
update_low_bdy = .false.
```

This updates the lateral boundary conditions (`wrf_bdy_file` will be overwritten by `da_update_bc`).

---

## Running gen\_be

Starting with WRFDA version 3.1, users have three choices to define the background error covariance (BE). We call them CV3, CV5, and CV6. With CV3 and CV5, the background errors are applied to the same set of the control variables, stream function, unbalanced potential velocity, unbalanced temperature, unbalanced surface pressure, and pseudo-relative-humidity. However, for CV6 the moisture control variable is the unbalanced part of pseudo-relative-humidity. With CV3, the control variables are in physical space while with CV5 and CV6, the control variables are in eigenvector space. The major difference between these two kinds of BE is the vertical covariance; CV3 uses the vertical recursive filter to model the vertical covariance but CV5 and CV6 use an empirical orthogonal function (EOF) to represent the vertical covariance. The recursive filters to model the horizontal covariance are also different with these BEs. We have not conducted the systematic comparison of the analyses based on these BEs. However, CV3 (a BE file provided with our WRFDA system) is a global BE and can be used for any regional domain, while CV5 and CV6 BE's are domain-dependent, which should be generated based on the forecast data from the same domain. At this time, it is hard to tell which BE is better; the impact on analysis may vary from case to case.

CV3 is the NCEP background error covariance. It is estimated in grid space by what has become known as the NMC method (Parrish and Derber 1992). The statistics are estimated with the differences of 24 and 48-hour GFS forecasts with T170 resolution, valid at the same time for 357 cases, distributed over a period of one year. Both the amplitudes and the scales of the background error have to be tuned to represent the forecast error in the estimated fields. The statistics that project multivariate relations among variables are also derived from the NMC method.

The variance of each variable, and the variance of its second derivative, are used to estimate its horizontal scales. For example, the horizontal scales of the stream function can be estimated from the variance of the vorticity and stream function.

The vertical scales are estimated with the vertical correlation of each variable. A table is built to cover the range of vertical scales for the variables. The table is then used to find the scales in vertical grid units. The filter profile and the vertical correlation are fitted locally. The scale of the best fit from the table is assigned as the scale of the variable at that vertical level for each latitude. Note that the vertical scales are locally defined so that the negative correlation further away, in the vertical direction, is not included.

Theoretically, CV3 BE is a generic background error statistics file, which can be used for any case. It is quite straightforward to use CV3 in your own case. To use the CV3 BE file in your case, set `cv_options=3` in `&wrfvar7` in `namelist.input` in your working directory, and use the `be.dat` is located in `WRFDA/var/run/be.dat.cv3`.

To use CV5 or CV6 background error covariance, it is necessary to generate your domain-specific background error statistics with the `gen_be` utility. The background error statistics file, supplied with the tutorial test case, can NOT be used for your applications.

The Fortran main programs for `gen_be` can be found in `WRFDA/var/gen_be`. The executables of `gen_be` should have been created when you compiled the WRFDA code (as described earlier). The scripts to run these codes are in `WRFDA/var/scripts/gen_be`.

The input data for `gen_be` are WRF forecasts, which are used to generate model perturbations, used as a proxy for estimates of forecast error. For the NMC-method, the model perturbations are differences between forecasts (e.g. T+24 minus T+12 is typical for regional applications, T+48 minus T+24 for global) valid at the same time. Climatological estimates of background error may then be obtained by averaging these forecast differences over a period of time (e.g. one month). Given input from an ensemble prediction system (EPS), the inputs are the ensemble forecasts, and the model perturbations created are the transformed ensemble perturbations. The `gen_be` code has been designed to work with either forecast difference or ensemble-based perturbations. The former is illustrated in this tutorial example.

It is important to include forecast differences, from at least 00Z and 12Z through the period, to remove the diurnal cycle (i.e. do not run `gen_be` using just 00Z or 12Z model perturbations alone).

The inputs to `gen_be` are netCDF WRF forecast output ("wrfout") files at specified forecast ranges. To avoid unnecessary large single data files, it is assumed that all forecast ranges are output to separate files. For example, if we wish to calculate BE statistics using the NMC-method with (T+24)-(T+12) forecast differences (default for regional) then by setting the WRF `namelist.input` options `history_interval=720`, and `frames_per_outfile=1` we get the necessary output datasets. Then the forecast output files should be arranged as follows: directory name is the forecast initial time, time info in the file name is the forecast valid time. `2008020512/wrfout_d01_2008-02-06_00:00:00` means a 12-hour forecast valid at 2008020600, initialized at 2008020512.

Example dataset for a test case (90 x 60 x 41 gridpoints) can be downloaded from <http://www.mmm.ucar.edu/wrf/users/wrfda/download/testdata.html>. Untar the `gen_be_forecasts_20080205.tar.gz` file. You will have:

```
>ls $FC_DIR
-rw-r--r-- 1 users 11556492 2008020512/wrfout_d01_2008-02-06_00:00:00
-rw-r--r-- 1 users 11556492 2008020512/wrfout_d01_2008-02-06_12:00:00
-rw-r--r-- 1 users 11556492 2008020600/wrfout_d01_2008-02-06_12:00:00
-rw-r--r-- 1 users 11556492 2008020600/wrfout_d01_2008-02-07_00:00:00
-rw-r--r-- 1 users 11556492 2008020612/wrfout_d01_2008-02-07_00:00:00
-rw-r--r-- 1 users 11556492 2008020612/wrfout_d01_2008-02-07_12:00:00
```

In the above example, only 1 day (12Z 05 Feb to 12Z 06 Feb, 2002) of forecasts, every 12 hours is supplied to `gen_be_wrapper` to estimate forecast error covariance. It is only for demonstration. The minimum number of forecasts required depends on the application, number of grid points, etc. Month-long (or longer) datasets are typical for the NMC-method. Generally, at least a 1-month dataset should be used.

Under `WRFDA/var/scripts/gen_be`, `gen_be_wrapper.ksh` is used to generate the BE data. The following variables need to be set to fit your case:

```
export WRFVAR_DIR=/users/noname/work/code/trunk/phoenix_g95_opt/WRFDA
export START_DATE=2008020612 # the first perturbation valid date
export END_DATE=2008020700 # the last perturbation valid date
export NUM_LEVELS=40 # e_vert - 1
export BIN_TYPE=5
export FC_DIR=/users/noname/work/exps/friendlies/expt/fc # where wrf forecasts are
export RUN_DIR=/users/noname/work/exps/friendlies/gen_be${BIN_TYPE}
```

**Note:** The `START_DATE` and `END_DATE` are perturbation valid dates. As shown in the forecast list above, when you have 24-hour and 12-hour forecasts initialized at 2008020512, through 2008020612, the first and final forecast difference valid dates are 2008020612 and 2008020700, respectively.

**Note:** The forecast dataset should be located in `$FC_DIR`. Then type:

```
> gen_be_wrapper.ksh
```

Once the `gen_be_wrapper.ksh` run is completed, the `be.dat` can be found under the `$RUN_DIR` directory.

To get a clear idea about what is included in `be.dat`, the script `gen_be_plot_wrapper.ksh` may be used. This plots various data in `be.dat`; for example:

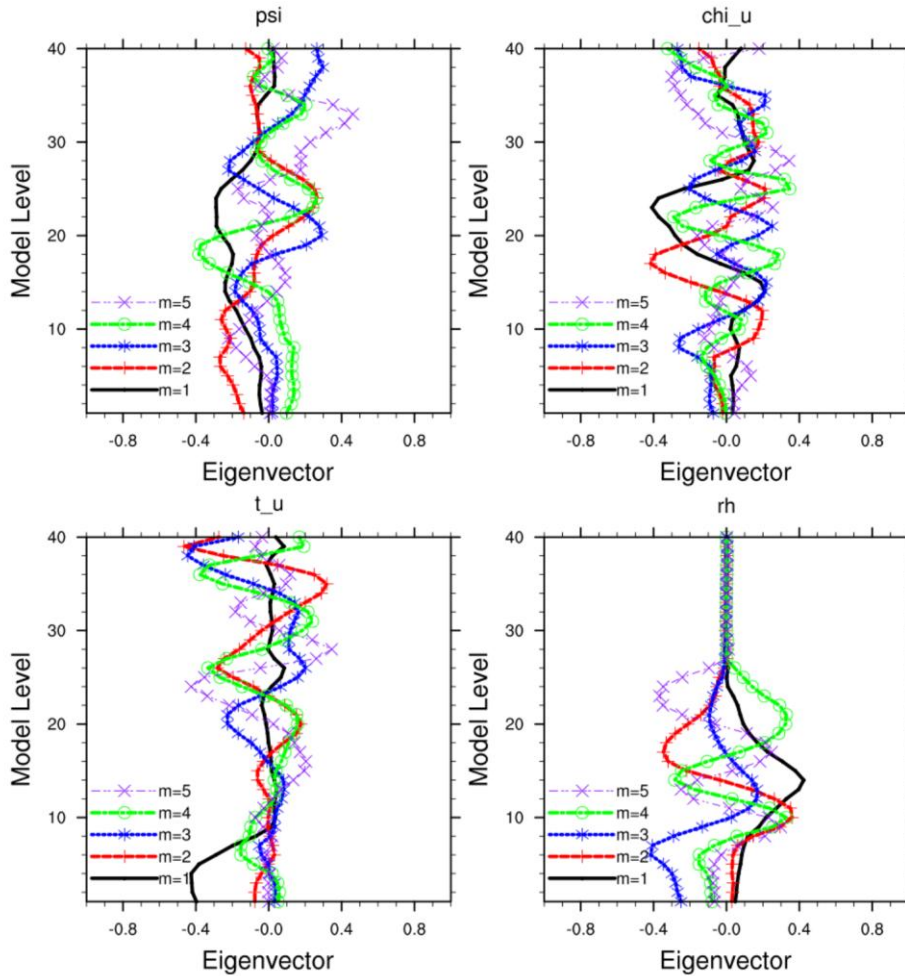

## Additional WRFDA Exercises:

### a. Single Observation response in WRFDA:

With the single observation test, you may get some ideas of how the background and observation error statistics work in the model variable space. A single observation test is done in WRFDA by setting `num_pseudo=1`, along with other pre-specified values in `record &wrfvar15` and `&wrfvar19` of `namelist.input`,

With the settings shown below, WRFDA generates a single observation with a pre-specified *innovation* (Observation – First Guess) value at the desired location; e.g. at (in terms of grid coordinate) 23x23, level 14 for “U” observation with error characteristics 1 m/s, and innovation size = 1.0 m/s.

```
&wrfvar15
num_pseudo = 1,
pseudo_x = 23.0,
pseudo_y = 23.0,
```

---

```

pseudo_z = 14.0,
pseudo_err = 1.0,
pseudo_val = 1.0,
/
&wrfvar19
pseudo_var = "u", (Note: pseudo_var can be u, v, t, p, q.
If pseudo_var is q, then the reasonable values of pseudo_err and
pseudo_val are 0.001)
/

```

Note: You may wish to repeat this exercise for other observations, like temperature “t”, pressure “p”, specific humidity “q”, and so on.

### b. Response of BE length scaling parameter:

Run the single observation test with the following additional parameters in record `&wrfvar7` of `namelist.input`.

```

&wrfvar7
len_scaling1 = 0.5, # reduce psi length scale by 50%
len_scaling2 = 0.5, # reduce chi_u length scale by 50%
len_scaling3 = 0.5, # reduce T length scale by 50%
len_scaling4 = 0.5, # reduce q length scale by 50%
len_scaling5 = 0.5, # reduce Ps length scale by 50%
/

```

**Note:** You may wish to try the response of an individual variable by setting one parameter at a time. Note the spread of analysis increment.

### c. Response of changing BE variance:

Run the single observation test with the following additional parameters in record `&wrfvar7` of `namelist.input`.

```

&wrfvar7
var_scaling1 = 0.25, # reduce psi variance by 75%
var_scaling2 = 0.25, # reduce chi_u variance by 75%
var_scaling3 = 0.25, # reduce T variance by 75%
var_scaling4 = 0.25, # reduce q variance by 75%
var_scaling5 = 0.25, # reduce Ps variance by 75%
/

```

**Note:** You may wish to try the response of individual variable by setting one parameter at a time. Note the magnitude of analysis increments.

### d. Response of convergence criteria:

Run the tutorial case with

```
&wrfvar6
eps = 0.0001,
/
```

You may wish to compare various diagnostics with an earlier run.

#### **e. Response of outer loop on minimization:**

Run the tutorial case with

```
&wrfvar6
max_ext_its = 2,
/
```

With this setting, the “outer loop” for the minimization procedure will be activated. You may wish to compare various diagnostics with an earlier run.

**Note:** The Maximum permissible value for “MAX\_EXT\_ITS” is 10.

#### **f. Response of suppressing particular types of data in WRFDA:**

The types of observations that WRFDA gets to use actually depend on what is included in the observation file and the WRFDA namelist settings. For example, if you have SYNOP data in the observation file, you can suppress its usage in WRFDA by setting `use_synopobs=false` in record `&wrfvar4` of `namelist.input`. It is OK if there are no SYNOP data in the observation file and `use_synopobs=true`.

Turning on and off certain types of observations is widely used for assessing the impact of observations on data assimilations.

**Note:** It is important to go through the default “use\_\*” settings in record `&wrfvar4` in `WRFDA/Registry/Registry.wrfvar` to know what observations are activated in default.

#### **g. Utilizing wind speed/direction assimilation:**

Beginning with Version 3.5, WRFDA is able to assimilate wind speed and direction observations directly, rather than converting the wind to its u- and v-components prior to assimilation. This is a feature unique to WRFDA; further detail about this method can be found in the following publication:

Huang, X.-Y., F. Gao, N. A. Jacobs, and H. Wang, 2013: Assimilation of wind speed and direction observations: a new formulation and results from idealised experiments. *Tellus A*, 65, 19936, doi:10.3402/tellusa.v65i0.19936.

Wind speed/direction assimilation is controlled by the following namelist options:

```
&wrfvar2
```



---

|                           |                                                                                                                                                                          |
|---------------------------|--------------------------------------------------------------------------------------------------------------------------------------------------------------------------|
| <code>var_wind</code>     | true: wind values which are reported as speed/direction will be assimilated as such<br>false: (default behavior) all wind obs are converted to u/v prior to assimilation |
| <code>qc_rej_both</code>  | true: if either u or v (spd or dir) do not pass quality control, both obs are rejected<br>false: (default behavior) qc on wind obs is handled individually               |
| <code>&amp;wrfvar5</code> |                                                                                                                                                                          |
| <code>max_omb_sp</code>   | Max absolute value of innovation for wind speed obs in m/s; greater than this and the innovation will be set to zero (default: 14.0)                                     |
| <code>max_omb_dir</code>  | Max absolute value of innovation for wind direction obs in degrees; greater than this and the innovation will be set to zero (default: 135.0)                            |

The following settings only matter if `check_max_iv=true` (if innovation is greater than observation error times the error factor listed below, the observation will be rejected):

|                            |                                       |
|----------------------------|---------------------------------------|
| <code>max_error_sp</code>  | Speed error factor (default: 5.0)     |
| <code>max_error_dir</code> | Direction error factor (default: 5.0) |

## WRFDA with Multivariate Background Error (MBE) Statistics

A new control variable option to implement multivariate background error (MBE) statistics in WRFDA has been introduced. It may be activated by setting the namelist variable `cv_options=6`. This option introduces six additional correlation coefficients in the definition of the balanced part of analysis control variables. Thus with this implementation, moisture analysis is multivariate, in the sense that temperature and wind may lead to moisture increments, and vice-versa. The `gen_be` utility has also been updated to compute the desired MBE statistics required for this option. The updates include basic source code, scripts, and graphics to display some important diagnostics about MBE statistics. Further details may be seen at:

[http://www.mmm.ucar.edu/wrf/users/wrfda/Docs/WRFDA\\_updated\\_for\\_cv6.pdf](http://www.mmm.ucar.edu/wrf/users/wrfda/Docs/WRFDA_updated_for_cv6.pdf)

### a. How to generate multivariate background error statistics for WRFDA

Multivariate background error statistics for WRFDA is generated by executing a top-level script, `gen_be/wrapper_gen_be_gsi.ksh`, residing under `SCRIPTS_DIR` via a suitable wrapper script. The rest of the procedure remains the same as with normal running of the `gen_be` utility. A successful run will create a `be.dat` file in the `RUN_DIR` directory.

### b. How to run WRFDA with multivariate background error statistics

After successfully generating the multivariate background error statistics file `be.dat`, the procedure for running WRFDA is straight-forward. If WRFDA is run through the wrapper script, suitably declare the namelist variable `NL_CV_OPTIONS=6` in the “wrapper” script. If WRFDA is run directly (by executing `da_wrfvar.exe`), then include `cv_options=6` in the `namelist.input` file under the `&wrfvar7` list of namelist options.

### c. How to tune multivariate background error statistics in running WRFDA

Below is a list of nine tuning parameters available in WRFDA. Default values for these variables are set as “1.0”. Setting corresponding values  $> 1.0$  ( $< 1.0$ ) will increase (decrease) the corresponding contributions as described in the following Table:

| <b>Variable name</b>         | <b>Description</b>                                                                                                       |
|------------------------------|--------------------------------------------------------------------------------------------------------------------------|
| <code>psi_chi_factor</code>  | Parameter to control contribution of stream function in defining balanced part of velocity potential                     |
| <code>psi_t_factor</code>    | Parameter to control contribution of stream function in defining balanced part of temperature                            |
| <code>psi_ps_factor</code>   | Parameter to control contribution of stream function in defining balanced part of surface pressure                       |
| <code>psi_rh_factor</code>   | Parameter to control contribution of stream function in defining balanced part of moisture                               |
| <code>chi_u_t_factor</code>  | Parameter to control contribution of unbalanced part of velocity potential in defining balanced part of temperature      |
| <code>chi_u_ps_factor</code> | Parameter to control contribution of unbalanced part of velocity potential in defining balanced part of surface pressure |
| <code>chi_u_rh_factor</code> | Parameter to control contribution of unbalanced part of velocity potential in defining balanced part of moisture         |
| <code>t_u_rh_factor</code>   | Parameter to control contribution of unbalanced part of temperature in defining balanced part of moisture                |
| <code>ps_u_rh_factor</code>  | Parameter to control contribution of unbalanced part of surface pressure in defining balanced part of moisture           |

## WRFDA Diagnostics

WRFDA produces a number of diagnostic files that contain useful information on how the data assimilation has performed. This section will introduce you to some of these files, and what to look for.

After running WRFDA, it is important to check a number of output files to see if the assimilation appears sensible. The WRFDA package, which includes several useful scripts, may be downloaded from

<http://www.mmm.ucar.edu/wrf/users/wrfda/download/tools.html>

The content of some useful diagnostic files are as follows:

`cost_fn` and `grad_fn`: These files hold (in ASCII format) WRFDA cost and gradient function values, respectively, for the first and last iterations. If you run with `PRINT_DETAIL_GRAD=true`, however, these values will be listed for each iteration; this can be helpful for visualization purposes. The NCL script `WRFDA/var/graphics/ncl/plot_cost_grad_fn.ncl` may be used to plot the content of `cost_fn` and `grad_fn`, if these files are generated with `PRINT_DETAIL_GRAD=true`.

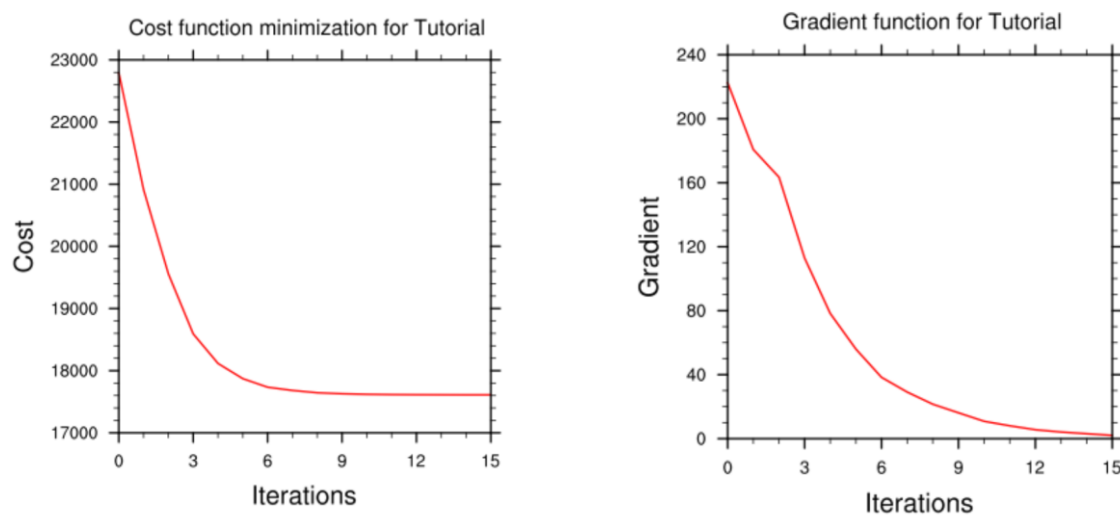

**Note:** Make sure that you remove the first two lines (header) in `cost_fn` and `grad_fn` before you plot. You also need to specify the directory name for these two files.

`gts_omb_oma_01`: It contains (in ASCII format) information on all of the observations used by the WRFDA run. Each observation has its observed value, quality flag, observation error, observation minus background (OMB), and observation minus analysis (OMA). This information is very useful for both analysis and forecast verification purposes.

`namelist.input`: This is the WRFDA input namelist file, which contains all the user-defined non-default options. Any namelist-defined options that do not appear in this file

should have their names checked against the values in

```
$WRFDA_DIR/Registry/Registry.wrfvar.
```

`namelist.output`: A consolidated list of all the namelist options used.

`rs1*`: Files containing information for standard WRFDA output from individual processors when multiple processors are used. It contains a host of information on a number of observations, minimization, timings, etc. Additional diagnostics may be printed in these files by including various “print” WRFDA namelist options. To learn more about these additional “print” options, search for the “print\_” string in

```
$WRFDA_DIR/Registry/Registry.wrfvar.
```

`statistics`: Text file containing OMB (OI) and OMA (OA) statistics (minimum, maximum, mean and standard deviation) for each observation type and variable. This information is very useful in diagnosing how WRFDA has used different components of the observing system. Also contained are the analysis minus background (A-B) statistics, i.e. statistics of the analysis increments for each model variable at each model level. This information is very useful in checking the range of analysis increment values found in the analysis, and where they are in the WRF-model grid space.

The WRFDA analysis file is `wrfvar_output`. It is in WRF (netCDF) format. It will become the input file `wrfinput_d01` of any subsequent WRF run after lateral boundary and/or lower boundary conditions are updated by another WRFDA utility (See the section [Updating WRF boundary conditions](#)).

An NCL script, `$WRFDA_DIR/var/graphics/ncl/WRF-Var_plot.ncl`, is provided for plotting. You need to specify the `analysis_file` name, its full path, etc. Please see the in-line comments in the script for details.

As an example, if you are aiming to display the U-component of the analysis at level 18, execute the following command after modifying the script

`WRFDA/var/graphics/ncl/WRF-Var_plot.ncl`, and make sure the following pieces of codes are uncommented:

```
var = "U"
fg = first_guess->U
an = analysis->U
plot_data = an
```

When you execute the following command from `$WRFDA_DIR/var/graphics/ncl`.

```
> ncl WRF-Var_plot.ncl
```

The plot should look like:

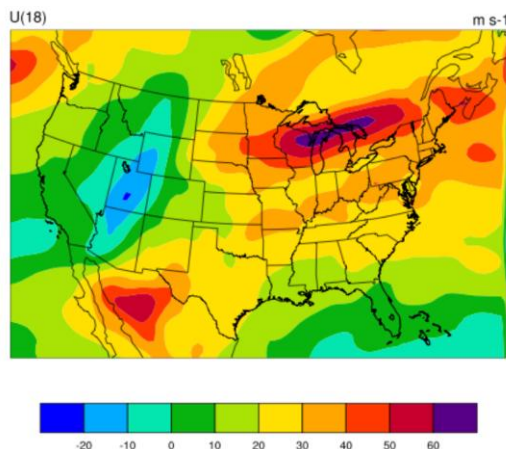

You may change the variable name, level, etc. in this script to display the variable of your choice at the desired eta level.

Take time to look through the text output files to ensure you understand how WRFDA works. For example:

How closely has WRFDA fit individual observation types? Look at the `statistics` file to compare the O-B and O-A statistics.

How big are the analysis increments? Again, look in the `statistics` file to see minimum/maximum values of A-B for each variable at various levels. It will give you a feel for the impact of the input observation data you assimilated via WRFDA by modifying the input analysis first guess.

How long did WRFDA take to converge? Does it really converge? You will get the answers of all these questions by looking into `rsl`-files, as it indicates the number of iterations taken by WRFDA to converge. If this is the same as the maximum number of iterations specified in the namelist (`NTMAX`), or its default value (=200) set in `$WRFDA_DIR/Registry/Registry.wrfvar`, then it means that the analysis solution did not converge. If this is the case, you may need to increase the value of “`NTMAX`” and rerun your case to ensure that the convergence is achieved. On the other hand, a normal WRFDA run should usually converge within 100 iterations. If it still doesn’t converge in 200 iterations, that means there may be a problem in the observations or first guess.

A good way to visualize the impact of assimilation of observations is to plot the analysis increments (i.e. analysis minus the first guess difference). Many different graphics packages (e.g. RIP4, NCL, GRADS etc) can do this. The plot of level 18 theta increments below was produced using this particular NCL script. This script is located at `$WRFDA_DIR/var/graphics/ncl/WRF-Var_plot.ncl`.

You need to modify this script to fix the full path for `first_guess` and `analysis` files.

You may also use it to modify the display level by setting `k1` and the name of the variable to display by setting `var`. Further details are given in this script.

If you are aiming to display the increment of potential temperature at level 18, after modifying `$WRFDA_DIR/var/graphics/ncl/WRF-Var_plot.ncl`, make sure the following pieces of code are uncommented:

```
var = "T"
fg = first_guess->T ;Theta- 300
an = analysis->T ;Theta- 300
plot_data = an - fg
```

When you execute the following command from `WRFDA_DIR/var/graphics/ncl`.

```
> ncl WRF-Var_plot.ncl
```

The plot created will look as follows:

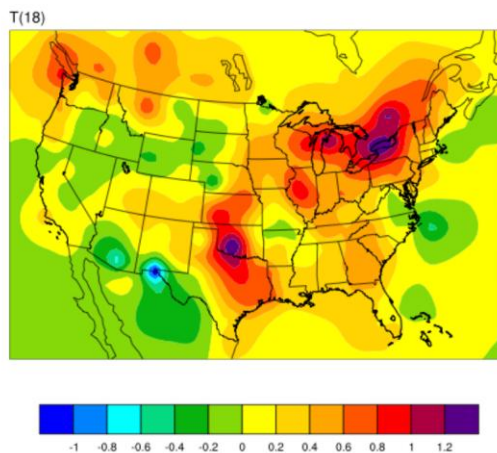

Note: Larger analysis increments indicate a larger data impact in the corresponding region of the domain.

## Hybrid Data Assimilation in WRFDA

The WRFDA system also includes a hybrid data assimilation technique, which is based on the existing 3D-Var. The difference between hybrid and 3D-Var schemes is that 3D-Var relies solely on a static covariance model to specify the background errors, while the hybrid system uses a combination of 3D-Var static error covariances and ensemble-estimated error covariances to incorporate a flow-dependent estimate of the background error statistics. Please refer to Wang et al. (2008a,b) for a detailed description of the methodology used in the WRF hybrid system. The following section will give a brief introduction of some aspects of using the hybrid system.

---

## a. Source Code

Four executables are used in the hybrid system. If you have successfully compiled the WRFDA system, you will see the following:

```
WRFDA/var/build/gen_be_ensmean.exe
WRFDA/var/build/gen_be_ep2.exe
WRFDA/var/build/da_wrfvar.exe
WRFDA/var/build/gen_be_vertloc.exe
```

`gen_be_ensmean.exe` is used to calculate the ensemble mean, while `gen_be_ep2.exe` is used to calculate the ensemble perturbations. `gen_be_vertloc.exe` is used for vertical localization. As with 3D-Var/4D-Var, `da_wrfvar.exe` is the main WRFDA program. However, in this case, `da_wrfvar.exe` will run in the hybrid mode.

## b. Running The Hybrid System

The procedure is the same as running 3D-Var/4D-Var, with the exception of some extra input files and namelist settings. The basic input files for WRFDA are `LANDUSE.TBL`, `ob.ascii` or `ob.bufr` (depending on which observation format you use), and `be.dat` (static background errors). Additional input files required by the hybrid are a single ensemble mean file (used as the `fg` for the hybrid application) and a set of ensemble perturbation files (used to represent flow-dependent background errors).

A set of initial ensemble members must be prepared before the hybrid application can be started. The ensemble can be obtained from other ensemble model outputs, or you can generate them yourself. This can be done, for example, adding random noise to the initial conditions at a previous time and integrating each member to the desired time. A tutorial case with a test ensemble can be found at [http://www.mmm.ucar.edu/wrf/users/wrfda/Tutorials/2011\\_July/data/wrfda\\_hybrid\\_testdata.tar.gz](http://www.mmm.ucar.edu/wrf/users/wrfda/Tutorials/2011_July/data/wrfda_hybrid_testdata.tar.gz). In this example, the ensemble forecasts were initialized at 2006102712 and valid 2006102800. A hybrid analysis at 2006102800 will be performed using the ensemble valid 2006102800 as input. Once you have the initial ensemble, the ensemble mean and perturbations can be calculated following the steps below:

- 1) Set an environment variable for your working directory and your data directory

```
> setenv WORK_DIR your_hybrid_path
> setenv DAT_DIR your_data_path
> cd $WORK_DIR
```

- 2) Calculate the ensemble mean

- a) From your working directory, copy or link the ensemble forecasts to your work-

ing directory. The ensemble members are identified by three-digit numbers following the valid time.

```
> ln -sf $DAT_DIR/Hybrid/fc/2006102712/wrfout_d01_2006-10-28_00:00:00.e* .
```

- b) Provide two template files (ensemble mean and variance files) in your working directory. These files will be overwritten with the ensemble mean and variance as discussed below.

```
> cp $DAT_DIR/Hybrid/fc/2006102712/wrfout_d01_2006-10-28_00:00:00.e001 ./wrfout_d01_2006-10-28_00:00:00.mean
> cp $DAT_DIR/Hybrid/fc/2006102712/wrfout_d01_2006-10-28_00:00:00.e001 ./wrfout_d01_2006-10-28_00:00:00.vari
```

- c) Copy `gen_be_ensmean_nl.nl` (`cp $DAT_DIR/Hybrid/gen_be_ensmean_nl.nl` .) You will need to set the information in this script as follows:

```
&gen_be_ensmean_nl
directory = '.'
filename = 'wrfout_d01_2006-10-28_00:00:00'
num_members = 10
nv = 7
cv = 'U', 'V', 'W', 'PH', 'T', 'MU', 'QVAPOR' \
```

where `directory` is the folder containing the ensemble members and template files, `filename` is the name of the files before their suffixes (e.g., `.mean`, `.vari`, etc), `num_members` is the number of ensemble members you are using, `nv` is the number of variables, and `cv` is the name of variables used in the hybrid system. Be sure `nv` and `cv` are consistent!

- d) Link `gen_be_ensmean.exe` to your working directory and run it.

```
> ln -sf $WRFDA_DIR/var/build/gen_be_ensmean.exe .
> ./gen_be_ensmean.exe
```

Check the output files. `wrfout_d01_2006-10-28_00:00:00.mean` is the ensemble mean; `wrfout_d01_2006-10-28_00:00:00.vari` is the ensemble variance

### 3) Calculate ensemble perturbations

- a) Create a sub-directory in which you will be working to create ensemble perturbations.

```
> mkdir -p ./ep
> cd ./ep
```

- b) Run `gen_be_ep2.exe`. The executable requires four command-line arguments (DATE, NUM\_MEMBER, DIRECTORY, and FILENAME) as shown below for the tutorial



example:

```
> ln -sf WRFDA/var/build/gen_be_ep2.exe .
> ./gen_be_ep2.exe 2006102800 10 . ../wrfout_d01_2006-10-28_00:00:00
```

c) Check the output files. A list of binary files should now exist. Among them, `tmp.e*` are temporary scratch files that can be removed.

4) Back in the working directory, create the input file for vertical localization. This program requires one command-line argument: the number of vertical levels of the model configuration (same value as `e_vert` in the namelist; for the tutorial example, this should be 42).

```
> cd $WORK_DIR
> ln -sf $WRFDA_DIR/var/build/gen_be_vertloc.exe .
> ./gen_be_vertloc.exe 42
```

The output is `./be.vertloc.dat` in your working directory.

5) Run WRFDA in hybrid mode

a) In your hybrid working directory, link all the necessary files and directories as follows:

```
> ln -fs ./ep/* .
> ln -fs ../wrfout_d01_2006-10-28_00:00:00.mean ./fg (first
guess is the ensemble mean)
> ln -fs $WRFDA_DIR/run/LANDUSE.TBL .
> ln -fs $DAT_DIR/Hybrid/ob/2006102800/ob.ascii ./ob.ascii (or
ob.bufr)
> ln -fs $DAT_DIR/Hybrid/be/be.dat ./be.dat
> ln -fs $WRFDA_DIR/var/build/da_wrfvar.exe .
> cp $DAT_DIR/Hybrid/namelist.input .
```

b) Edit `namelist.input`, paying special attention to the following hybrid-related settings:

```
&wrfvar7
je_factor = 2.0
/
&wrfvar16
ensdim_alpha = 10
alphacv_method = 2
alpha_corr_type=3
alpha_corr_scale = 1500.0
alpha_std_dev=1.000
alpha_vertloc = .true.
/
```

- c) Finally, execute the WRFDA file, running in hybrid mode

```
< ./da_wrfvar.exe >&! wrfda.log
```

Check the output files; the output file lists are the same as when you run WRF 3D-Var.

### c. Hybrid namelist options

#### **je\_factor**

ensemble covariance weighting factor. This factor controls the weighting component of ensemble and static covariances. The corresponding `jb_factor` = `je_factor/(je_factor - 1)`.

#### **ensdim\_alpha**

the number of ensemble members. Hybrid mode is activated when `ensdim_alpha` is larger than zero

#### **alphacv\_method**

1=perturbations in control variable space (“psi”, “chi\_u”, “t\_u”, “rh”, “ps\_u”);  
2=perturbations in model space (“u”, “v”, “t”, “q”, “ps”). Option 2 is extensively tested and recommended to use.

#### **alpha\_corr\_type**

correlation function. 1=Exponential; 2=SOAR; 3=Gaussian.

#### **alpha\_corr\_scale**

hybrid covariance localization scale in km unit. Default value is 1500.

#### **alpha\_std\_dev**

alpha standard deviation. Default value is 1.0

#### **alpha\_vertloc**

for vertical localization. `.true.`=use vertical localization; `.false.`=no vertical localization

## ETKF Data Assimilation

The WFDAR system also includes a ETKF assimilation technique. The ETKF system updates the ensemble perturbations. Please refer to Bishop et al. (2001) and Wang et al. (2003) for a detailed description of the methodology. The following section will give a brief introduction of some aspects of using the ETKF system.

### a. Source Code

Three executables are used in the ETKF system. If you have successfully compiled the WRFDA system, you will see the following:

```
WRFDA/var/build/gen_be_etkf.exe
```

```
WRFDA/var/build/gen_be_addmean.exe
```

```
WRFDA/var/build/da_wrfvar.exe
```

The file `gen_be_etkf.exe` is used to update the ensemble perturbations, while `gen_be_addmean.exe` is used to combine the ensemble mean and the ensemble perturbations. As with 3D-Var/4D-Var, `da_wrfvar.exe` is the main WRFDA program. However, in this case, `da_wrfvar.exe` will create filtered observations and prepare formatted omb files for ETKF.

## b. Running the ETKF System

The first procedure is to update the ensemble perturbations. A set of initial ensemble members must be prepared before the ETKF application can be started. The ensemble can be obtained from a previous ensemble forecast. A tutorial case with a test ensemble can be found at

[http://www.mmm.ucar.edu/wrf/users/wrfda/Tutorials/2011\\_July/data/wrfda\\_hybrid\\_etkf\\_testdata.tar.gz](http://www.mmm.ucar.edu/wrf/users/wrfda/Tutorials/2011_July/data/wrfda_hybrid_etkf_testdata.tar.gz). In this example, the ensemble forecasts were initialized at 2006102712 and valid 2006102800. ETKF will be performed using the ensemble valid 2006102800 as input. Once you have the initial ensemble, the ensemble perturbations can be updated by following the steps below:

### 1) Set an environment variable for your working directory and your data directory

```
> setenv WORK_DIR_ETKF your_etkf_path
> setenv DAT_DIR your_data_path
> cd $WORK_DIR_ETKF
```

### 2) Prepare the filtered observations

#### a) In your ETKF working directory, make a subdirectory to prepare the filtered observations and link all the necessary files and directories as follows:

```
> mkdir obs_filter
> cd obs_filter
> ln -fs $DAT_DIR/Hybrid/fc/2006102712/wrfout_d01_2006-10-
28_00:00:00.mean ./fg (first guess is the ensemble mean)
> ln -fs $WRFDA_DIR/run/LANDUSE.TBL .
> ln -fs $DAT_DIR/Hybrid/ob/2006102800/ob.ascii ./ob.ascii (or
ob.bufr)
> ln -fs $DAT_DIR/Hybrid/be/be.dat ./be.dat
> ln -fs $WRFDA_DIR/var/build/da_wrfvar.exe .
> cp $DAT_DIR/ETKF/namelist.input .
```

#### b) Edit `namelist.input`, paying special attention to the following 'QC-OBS'-related settings:

```
&wrfvar17
analysis_type = 'QC-OBS',
/
```

- c) Execute the WRFDA file, running in QC-OBS mode

```
< ./da_wrfvar.exe >&! wrfda.log
```

Check the output files; the output files are the same as when you run WRF 3D-Var, and the 'filtered\_obs\_01' file contains the filtered observations.

- 3) Prepare omb files for ETKF

- a) In your ETKF working directory, make a subdirectory to prepare the omb files for each ensemble member and link all the necessary files and directories as follows:

```
> cd $WORK_DIR_ETKF
> mkdir -p omb/working.e001
> cd omb/working.e001
> ln -fs $DAT_DIR/Hybrid/fc/2006102712/wrfout_d01_2006-10-
28_00:00:00.e001 ./fg (first guess is the ensemble member)
> ln -fs $WRFDA_DIR/run/LANDUSE.TBL .
> ln -fs $WORK_DIR_ETKF/obs_filter/filtered_obs_01 ./ob.ascii
> ln -fs $DAT_DIR/Hybrid/be/be.dat ./be.dat
> ln @Cfs $WRFDA_DIR/var/build/da_wrfvar.exe .
> cp $DAT_DIR/ETKF/namelist.input .
```

- b) Edit namelist.input, paying special attention to the following 'VERIFY'-related settings:

```
&wrfvar17
analysis_type = 'VERIFY',
/
```

- c) Execute the WRFDA file, running in VERIFY mode

```
< ./da_wrfvar.exe >&! wrfda.log
```

Check the output files. The output files are the same as when you run WRF 3D-Var, and the 'ob.etkf.0\*' files are omb files.

- d) Combine the ob.etkf.0\* files and add the observation number in the head of ob.etkf.e0\*

```
> cat ob.etkf.0* > ob.all
> wc -l ob.all > ob.etkf.e001
> cat ob.all >> ob.etkf.e001
```

- e) Likewise, prepare ob.etkf.e0\* files for other ensemble members

- 4) Run ETKF

a) Copy or link the ensemble mean and forecasts and ob.etkf.e0\* files to your working directory and make a parameter directory to save the parameter files.

```
> setenv PAR_DIR_ETKF your_parameter_path
> cd $WORK_DIR_ETKF
> ln -sf $DAT_DIR/Hybrid/fc/2006102712/wrfout_d01_2006-10-
28_00:00:00.mean ./etkf_input
> ln -sf $DAT_DIR/Hybrid/fc/2006102712/wrfout_d01_2006-10-
28_00:00:00.e001 ./etkf_input.e001
...
> ln -sf $DAT_DIR/Hybrid/fc/2006102712/wrfout_d01_2006-10-
28_00:00:00.e010 ./etkf_input.e010

> ln -sf omb/working.e001/ob.etkf.e001 .
...
> ln -sf omb/working.e010/ob.etkf.e010 .
```

b) Provide template files. These files will be overwritten with the ensemble perturbations.

```
> cp $DAT_DIR/Hybrid/fc/2006102712/wrfout_d01_2006-10-
28_00:00:00.e001 ./etkf_output.e001
...
> cp $DAT_DIR/Hybrid/fc/2006102712/wrfout_d01_2006-10-
28_00:00:00.e010 ./etkf_output.e010
```

c) Copy gen\_be\_etkf\_nl.nl (cp \$DAT\_DIR/ETKF/gen\_be\_etkf\_nl.nl.)  
You will need to set the information in this script as follows:

```
&gen_be_etkf_nl
 num_members = 10,
 nv = 7,
 cv = 'U', 'V', 'W', 'PH', 'T', 'QVAPOR', 'MU',
 naccumt1 = 20,
 naccumt2 = 20,
 nstartaccum1 = 1,
 nstartaccum2 = 1,
 nout = 1,
 tainflatinput = 1,
 rhoinput = 1,
 infl_fac_file = '$PAR_DIR_ETKF/inflation_factor.dat',
 infl_let_file = '$PAR_DIR_ETKF/inflation_letkf.dat',
 eigen_val_file = '$PAR_DIR_ETKF/eigen_value.dat',
 inno2_val_file = '$PAR_DIR_ETKF/innovation_value.dat',
 proj2_val_file = '$PAR_DIR_ETKF/projection_value.dat',
 infl_fac_TRNK = .false.,
 infl_fac_WG03 = .false.,
 infl_fac_WG07 = .true.,
 infl_fac_BOWL = .false.,
 letkf_flg=.false.,
 rand_filt = .false.,
 rnd_seed = 2006102800,
```

---

```

 rnd_nobs = 5000
 etkf_erro_max = 20.
 etkf_erro_min = .00001
 etkf_inno_max = 20.
 etkf_inno_min = .00001
 etkf_erro_flg = .true.
 etkf_inno_flg = .true.
 etkf_wrfda = .false.
/

```

Where num\_members is the ensemble members size, nv is the number of variables and cv the name of variables. naccumt1 and naccumt2 are number of previous cycles used to accumulate for inflation and rho factor. nstartaccum1 is the cycle from which naccumt1 cycle starts. nstartaccum2 is the cycle from which naccumt2 cycle starts. nout is the cycle index. tainflatinput and rhoinput are prescribed factors for inflation and rho factor. infl\_let\_file, eigen\_val\_file, inno2\_val\_file and proj2\_val\_file are files to save template parameters. infl\_fac\_TRNK, infl\_fac\_WG03, infl\_fac\_WG07 and infl\_fac\_BOWL are options for different adaptive inflation schemes. rand\_filt, rnd\_seed and rnd\_nobs are options for using filtered observation and random observations. etkf\_erro\_max, etkf\_erro\_min, etkf\_inno\_max, etkf\_inno\_min, etkf\_erro\_flg, etkf\_inno\_flg and etkf\_wrfda are options to conduct further observation filtering.

d) Link gen\_be\_etkf.exe to your working directory and run it.

```

> ln -sf $WRFDA_DIR/var/build/gen_be_etkf.exe .
> ./gen_be_etkf.exe

```

Check the output files. etkf\_output.\* files are updated ensemble perturbations.

5) Add updated ensemble perturbations to the ensemble mean to get new ensemble members

```

> cd $WORK_DIR_ETKF

```

a) Copy add\_mean\_nl.nl (cp \$DAT\_DIR/ETKF/add\_mean\_nl.nl .)

You will need to set the information in this script as follows for each member:

```

&add_mean_nl
num_members = 10
cv = 'U', 'V', 'W', 'PH', 'T', 'QVAPOR', 'MU'
nv = 7
path = '$WORK_DIR_ETKF'
file_mean = 'etkf_input'
file_pert = 'etkf_output.e001' (for each member,
etkf_output.e0*...)
/

```

b) Run gen\_add\_mean.exe.

---

```
> ln -sf WRFDA/var/build/gen_add_mean.exe .
> ./gen_add_mean.exe
```

Check the output files. etkf\_output.e0\* files are the new ensemble members.

## Description of Namelist Variables

WRFDA namelist variables.

| Variable Names      | Default Value | Description                                                                                                                                                                                                                                                                                                                                                                                  |
|---------------------|---------------|----------------------------------------------------------------------------------------------------------------------------------------------------------------------------------------------------------------------------------------------------------------------------------------------------------------------------------------------------------------------------------------------|
| <b>&amp;wrfvar1</b> |               |                                                                                                                                                                                                                                                                                                                                                                                              |
| write_increments    | false         | .true.: write out a binary analysis increment file                                                                                                                                                                                                                                                                                                                                           |
| var4d               | false         | .true.: 4D-Var mode                                                                                                                                                                                                                                                                                                                                                                          |
| var4d_lbc           | true          | .true.: on/off for lateral boundary control in 4D-Var                                                                                                                                                                                                                                                                                                                                        |
| var4d_bin           | 3600          | seconds, observation sub-window length for 4D-Var                                                                                                                                                                                                                                                                                                                                            |
| var4d_bin_rain      | 3600          | seconds, precipitation observation sub-window length for 4D-Var                                                                                                                                                                                                                                                                                                                              |
| multi_inc           | 0             | > 0: multi-incremental run                                                                                                                                                                                                                                                                                                                                                                   |
| print_detail_radar  | false         | print_detail_xxx: output extra (sometimes can be too many) diagnostics for debugging; not recommended to turn these on for production runs                                                                                                                                                                                                                                                   |
| print_detail_xa     | false         |                                                                                                                                                                                                                                                                                                                                                                                              |
| print_detail_xb     | false         |                                                                                                                                                                                                                                                                                                                                                                                              |
| print_detail_obs    | false         |                                                                                                                                                                                                                                                                                                                                                                                              |
| print_detail_grad   | false         | .true.: to print out a detailed gradient of each observation type at each iteration                                                                                                                                                                                                                                                                                                          |
| check_max_iv_print  | true          | obsolete (used only by Radar)                                                                                                                                                                                                                                                                                                                                                                |
| <b>&amp;wrfvar2</b> |               |                                                                                                                                                                                                                                                                                                                                                                                              |
| analysis_accu       | 900           | in seconds, if the time difference between the namelist setting (analysis_date) and date info read-in from the first guess is larger than analysis_accu, WRFDA will issue a warning message ("=====> Wrong xb time found???"), but won't abort.                                                                                                                                              |
| calc_w_increment    | false         | .true.: the increment of the vertical velocity, W, will be diagnosed based on the increments of other fields.<br>.false.: the increment of the vertical velocity W is zero if no W information is assimilated. If there is information on the W from observations assimilated, such as radar radial velocity, the W increments are always computed, whether calc_w_increment=true. or false. |
| <b>&amp;wrfvar3</b> |               |                                                                                                                                                                                                                                                                                                                                                                                              |
| fg_format           | 1             | 1: fg_format_wrf_arw_regional (default)<br>2: fg_format_wrf_nmm_regional                                                                                                                                                                                                                                                                                                                     |

---

|                     |       |                                                                                                                                                                                                                |
|---------------------|-------|----------------------------------------------------------------------------------------------------------------------------------------------------------------------------------------------------------------|
|                     |       | 3: fg_format_wrf_arw_global<br>4: fg_format_kma_global                                                                                                                                                         |
| ob_format           | 2     | 1: ob_format_bufr (NCEP PREPBUFR), read in data from ob.bufr (not fully tested)<br>2: ob_format_ascii (output from obsproc), read in data from ob.ascii (default)<br>3: ob_format_madis (not tested)           |
| num_fgat_time       | 1     | 1: 3DVar<br>> 1: number of time slots for FGAT and 4DVAR                                                                                                                                                       |
| <b>&amp;wrfvar4</b> |       |                                                                                                                                                                                                                |
| thin_conv           | true  | for ob_format=1 (NCEP PREPBUFR) only. thinning is mandatory for ob_format=1, as time-duplicate data are "thinned" within the thinning routine; however, thin_conv can be set to .false. for debugging purpose. |
| thin_mesh_conv      | 20.   | for ob_format=1 (NCEP PREPBUFR) only. (max_instrumerkm, each observation type can set its thinning mesh and the index/order follows the definition in WRFDA/var/da/da_control/da_control.f90                   |
| thin_rainobs        | true  | .true.: perform thinning on precipitation data                                                                                                                                                                 |
| use_synopobs        | true  | use_XXXobs - .true.: assimilate XXX obs if available                                                                                                                                                           |
| use_shipsobs        | true  | .false.: do not assimilate XXX obs even available                                                                                                                                                              |
| use_metarobs        | true  |                                                                                                                                                                                                                |
| use_soundobs        | true  |                                                                                                                                                                                                                |
| use_pilotobs        | true  |                                                                                                                                                                                                                |
| use_airepobs        | true  |                                                                                                                                                                                                                |
| use_geoamvobs       | true  |                                                                                                                                                                                                                |
| use_polaramvobs     | true  |                                                                                                                                                                                                                |
| use_bogusobs        | true  |                                                                                                                                                                                                                |
| use_buoyobs         | true  |                                                                                                                                                                                                                |
| use_profilerobs     | true  |                                                                                                                                                                                                                |
| use_satemobs        | true  |                                                                                                                                                                                                                |
| use_gpsspobs        | true  |                                                                                                                                                                                                                |
| use_gpsrefobs       | true  |                                                                                                                                                                                                                |
| use_qscatobs        | true  |                                                                                                                                                                                                                |
| use_radarobs        | false |                                                                                                                                                                                                                |
| use_radar_rv        | false |                                                                                                                                                                                                                |
| use_radar_rf        | false |                                                                                                                                                                                                                |
| use_rainobs         | false |                                                                                                                                                                                                                |
| use_airsretobs      | true  |                                                                                                                                                                                                                |
|                     |       | ; use_hirs2obs, use_hirs3obs, use_hirs4obs, use_mhsobs                                                                                                                                                         |
|                     |       | ; use_msuobs, use_amsuaobs, use_amsubobs, use_airsobs,                                                                                                                                                         |
|                     |       | ; use_eos_amsuaobs, use_hsbobs, use_ssmisobs are                                                                                                                                                               |
|                     |       | ; radiance-related variables that only control if                                                                                                                                                              |



; corresponding BUFR files are read into WRFDA or not, but  
 ; do not control if the data is assimilated or not.  
 ; Additional variables have to be set in &wrfvar14 in order  
 ; to assimilate radiance data.

|                  |       |                                                                                              |
|------------------|-------|----------------------------------------------------------------------------------------------|
| use_hirs2obs     | false | .true.: to read in data from hirs2.bufr                                                      |
| use_hirs3obs     | false | .true.: to read in data from hirs3.bufr                                                      |
| use_hirs4obs     | false | .true.: to read in data from hirs4.bufr                                                      |
| use_mhsobs       | false | .true.: to read in data from mhs.bufr                                                        |
| use_msuobs       | false | .true.: to read in data from msu.bufr                                                        |
| use_amsuaobs     | false | .true.: to read in data from amsua.bufr                                                      |
| use_amsubobs     | false | .true.: to read in data from amsub.bufr                                                      |
| use_airsobs      | false | .true.: to read in data from airs.bufr                                                       |
| use_eos_amsuaobs | false | .true.: to read in data from airs.bufr                                                       |
| use_hsbobs       | false | .true.: to read in data from hsb.bufr                                                        |
| use_ssmisobs     | false | .true.: to read in data from ssmis.bufr                                                      |
| use_iasisobs     | false | .true.: to read in data from iasi.bufr                                                       |
| use_obs_errfac   | false | .true.: apply obs error tuning factors if errfac.dat is available for conventional data only |

### **&wrfvar5**

|                     |      |                                                                                                                                                                                                                                                                                                                                                 |
|---------------------|------|-------------------------------------------------------------------------------------------------------------------------------------------------------------------------------------------------------------------------------------------------------------------------------------------------------------------------------------------------|
| check_max_iv        | true | .true.: reject the observations whose innovations (O-B) are larger than a maximum value defined as a multiple of the observation error for each observation. i.e., $inv > (obs\_error * factor)$ --> fails_error_max; the default maximum value is 5 times the observation error ; the factor of 5 can be changed through max_error_* settings. |
| max_error_t         | 5.0  | maximum check_max_iv error check factor for t                                                                                                                                                                                                                                                                                                   |
| max_error_uv        | 5.0  | maximum check_max_iv error check factor for u and v                                                                                                                                                                                                                                                                                             |
| max_error_pw        | 5.0  | maximum check_max_iv error check factor for precipitable water                                                                                                                                                                                                                                                                                  |
| max_error_ref       | 5.0  | maximum check_max_iv error check factor for gps refractivity                                                                                                                                                                                                                                                                                    |
| max_error_q         | 5.0  | maximum check_max_iv error check factor for specific humidity                                                                                                                                                                                                                                                                                   |
| max_error_p         | 5.0  | maximum check_max_iv error check factor for pressure                                                                                                                                                                                                                                                                                            |
| max_error_thickness | 5.0  | maximum check_max_iv error check factor for thickness                                                                                                                                                                                                                                                                                           |
| max_error_rv        | 5.0  | maximum check_max_iv error check factor for radar radial velocity                                                                                                                                                                                                                                                                               |
| max_error_rf        | 5.0  | maximum check_max_iv error check factor for radar reflectivity                                                                                                                                                                                                                                                                                  |

---

|                                                |       |                                                                                                                                                                                                                                                                                                                                  |
|------------------------------------------------|-------|----------------------------------------------------------------------------------------------------------------------------------------------------------------------------------------------------------------------------------------------------------------------------------------------------------------------------------|
| max_error_rain                                 | 5.0   | maximum check_max_iv error check factor for precipitation                                                                                                                                                                                                                                                                        |
| <b>&amp;wrfvar6 (for minimization options)</b> |       |                                                                                                                                                                                                                                                                                                                                  |
| max_ext_its                                    | 1     | number of outer loops                                                                                                                                                                                                                                                                                                            |
| ntmax                                          | 200   | maximum number of iterations in an inner loop                                                                                                                                                                                                                                                                                    |
| eps                                            | 0.01  | minimization convergence criterion (used dimension: max_ext_its); minimization stops when the norm of the gradient of the cost function gradient is reduced by a factor of eps. inner minimization stops either when the criterion is met or when inner iterations reach ntmax.                                                  |
| orthonorm_gradient                             | false | .true.: the gradient vectors are stored during the Conjugate Gradient for each iteration and used to re-orthogonalize the new gradient. This requires extra storage of large vectors (each one being the size of the control variable) but results in a better convergence of the Conjugate Gradient after around 20 iterations. |
| <b>&amp;wrfvar7</b>                            |       |                                                                                                                                                                                                                                                                                                                                  |
| cv_options                                     | 5     | 3: NCEP Background Error model<br>5: NCAR Background Error model (default)<br>6: Use of multivariate background error statistics                                                                                                                                                                                                 |
| as1 (3)                                        | -1.0  | tuning factors for variance, horizontal and vertical scales for control variable 1 - stream function. For cv_options=3 only. The actual default values are 0.25, 1.0, 1.5.                                                                                                                                                       |
| as2 (3)                                        | -1.0  | tuning factors for variance, horizontal and vertical scales for control variable 2 - unbalanced potential velocity. For cv_options=3 only. The actual default values are 0.25, 1.0, 1.5.                                                                                                                                         |
| as3 (3)                                        | -1.0  | tuning factors for variance, horizontal and vertical scales for control variable 3 - unbalanced temperature. For cv_options=3 only. The actual default values are 0.25, 1.0, 1.5.                                                                                                                                                |
| as4 (3)                                        | -1.0  | tuning factors for variance, horizontal and vertical scales for control variable 4 - pseudo relative humidity. For cv_options=3 only. The actual default values are 0.25, 1.0, 1.5.                                                                                                                                              |
| as5 (3)                                        | -1.0  | tuning factors for variance, horizontal and vertical scales for control variable 5 - unbalanced surface pressure. For cv_options=3 only. The actual default values are 0.25, 1.0, 1.5.                                                                                                                                           |
| rf_passes                                      | 6     | number of passes of recursive filter.                                                                                                                                                                                                                                                                                            |
| var_scaling1                                   | 1.0   | tuning factor of background error covariance for control variable 1 - stream function. For cv_options=5 only.                                                                                                                                                                                                                    |

---

|                               |     |                                                                                                                                                                                                                                                                                                                                               |
|-------------------------------|-----|-----------------------------------------------------------------------------------------------------------------------------------------------------------------------------------------------------------------------------------------------------------------------------------------------------------------------------------------------|
| var_scaling2                  | 1.0 | tuning factor of background error covariance for control variable 2 - unbalanced velocity potential. For cv_options=5 only.                                                                                                                                                                                                                   |
| var_scaling3                  | 1.0 | tuning factor of background error covariance for control variable 3 - unbalanced temperature. For cv_options=5 only.                                                                                                                                                                                                                          |
| var_scaling4                  | 1.0 | tuning factor of background error covariance for control variable 4 - pseudo relative humidity. For cv_options=5 only.                                                                                                                                                                                                                        |
| var_scaling5                  | 1.0 | tuning factor of background error covariance for control variable 5 - unbalanced surface pressure. For cv_options=5 only.                                                                                                                                                                                                                     |
| len_scaling1                  | 1.0 | tuning factor of scale-length for stream function. For cv_options=5 only.                                                                                                                                                                                                                                                                     |
| len_scaling2                  | 1.0 | tuning factor of scale-length for unbalanced velocity potential. For cv_options=5 only.                                                                                                                                                                                                                                                       |
| len_scaling3                  | 1.0 | tuning factor of scale-length for unbalanced temperature. For cv_options=5 only.                                                                                                                                                                                                                                                              |
| len_scaling4                  | 1.0 | tuning factor of scale-length for pseudo relative humidity. For cv_options=5 only.                                                                                                                                                                                                                                                            |
| len_scaling5                  | 1.0 | tuning factor of scale-length for unbalanced surface pressure. For cv_options=5 only.                                                                                                                                                                                                                                                         |
| je_factor                     | 1.0 | ensemble covariance weighting factor                                                                                                                                                                                                                                                                                                          |
| <b>&amp;wrfvar8 ;not used</b> |     |                                                                                                                                                                                                                                                                                                                                               |
| <b>&amp;wrfvar9</b>           |     | for program tracing. trace_use=.true. gives additional performance diagnostics (calling tree, local routine timings, overall routine timings, & memory usage). It does not change results, but does add runtime overhead.                                                                                                                     |
| stdout                        | 6   | unit number for standard output                                                                                                                                                                                                                                                                                                               |
| stderr                        | 0   | unit number for error output                                                                                                                                                                                                                                                                                                                  |
| trace_unit                    | 7   | Unit number for tracing output. Note that units 10 and 9 are reserved for reading namelist.input and writing namelist.output respectively.                                                                                                                                                                                                    |
| trace_pe                      | 0   | Currently, statistics are always calculated for all processors, and output by processor 0.                                                                                                                                                                                                                                                    |
| trace_repeat_head             | 10  | the number of times any trace statement will produce output for any particular routine. This stops overwhelming trace output when a routine is called multiple times. Once this limit is reached a 'going quiet' message is written to the trace file, and no more output is produced from the routine, though statistics are still gathered. |
| trace_repeat_body             | 10  | see trace_repeat_head description                                                                                                                                                                                                                                                                                                             |
| trace_max_depth               | 30  | define the deepest level to which tracing writes output                                                                                                                                                                                                                                                                                       |

---

---

|                                           |                    |                                                                                                                                                                                                                                                                                                                                                                                                            |
|-------------------------------------------|--------------------|------------------------------------------------------------------------------------------------------------------------------------------------------------------------------------------------------------------------------------------------------------------------------------------------------------------------------------------------------------------------------------------------------------|
| <code>trace_use</code>                    | <code>false</code> | <code>.true.:</code> activate tracing                                                                                                                                                                                                                                                                                                                                                                      |
| <code>trace_use_frequent</code>           | <code>false</code> |                                                                                                                                                                                                                                                                                                                                                                                                            |
| <code>trace_use_dull</code>               | <code>false</code> |                                                                                                                                                                                                                                                                                                                                                                                                            |
| <code>trace_memory</code>                 | <code>true</code>  | <code>.true.:</code> calculate allocated memory using a <code>mallinfo</code> call. On some platforms (Cray and Mac), <code>mallinfo</code> is not available and no memory monitoring can be done.                                                                                                                                                                                                         |
| <code>trace_all_pes</code>                | <code>false</code> | <code>.true.:</code> tracing is output for all pes. As stated in <code>trace_pe</code> , this does not change processor statistics.                                                                                                                                                                                                                                                                        |
| <code>trace_csv</code>                    | <code>true</code>  | <code>.true.:</code> tracing statistics are written to a <code>xxxx.csv</code> file in CSV format                                                                                                                                                                                                                                                                                                          |
| <code>use_html</code>                     | <code>true</code>  | <code>.true.:</code> tracing and error reporting routines will include HTML tags.                                                                                                                                                                                                                                                                                                                          |
| <code>warnings_are_fatal</code>           | <code>false</code> | <code>.true.:</code> warning messages that would normally allow the program to continue are treated as fatal errors.                                                                                                                                                                                                                                                                                       |
| <b>&amp;wrfvar10 (for code developer)</b> |                    |                                                                                                                                                                                                                                                                                                                                                                                                            |
| <code>test_transforms</code>              | <code>false</code> | <code>.true.:</code> perform adjoint tests                                                                                                                                                                                                                                                                                                                                                                 |
| <code>test_gradient</code>                | <code>false</code> | <code>.true.:</code> perform gradient test                                                                                                                                                                                                                                                                                                                                                                 |
| <b>&amp;wrfvar11</b>                      |                    |                                                                                                                                                                                                                                                                                                                                                                                                            |
| <code>cv_options_hum</code>               | <code>1</code>     | do not change                                                                                                                                                                                                                                                                                                                                                                                              |
| <code>check_rh</code>                     | <code>0</code>     | 0 --> No supersaturation check after minimization.<br>1 --> supersaturation ( $rh > 100\%$ ) and minimum rh ( $rh < 10\%$ ) check, and make the local adjustment of q.<br>2 --> supersaturation ( $rh > 95\%$ ) and minimum rh ( $rh < 11\%$ ) check and make the multi-level q adjustment under the constraint of conserved column integrated water vapor                                                 |
| <code>sfc_assi_options</code>             | <code>1</code>     | 1 --> surface observations will be assimilated based on the lowest model level first guess. Observations are not used when the elevation difference between the observing site and the lowest model level is larger than 100m.<br>2 --> surface observations will be assimilated based on surface similarity theory in PBL. Innovations are computed based on 10-m wind, 2-m temperature and 2-m moisture. |
| <code>calculate_cg_cost_fn</code>         | <code>false</code> | conjugate gradient algorithm does not require the computation of cost function at every iteration during minimization.<br><code>.true.:</code> Compute and write out cost function and gradient for each iteration into files <code>cost_fn</code> and <code>grad_fn</code> .<br><code>false.:</code> Only the initial and final cost functions are computed and output.                                   |

---

|                      |       |                                                                                                                                         |
|----------------------|-------|-----------------------------------------------------------------------------------------------------------------------------------------|
| lat_stats_option     | false | do not change                                                                                                                           |
| <b>&amp;wrfvar12</b> |       |                                                                                                                                         |
| balance_type         | 1     | obsolete                                                                                                                                |
| <b>&amp;wrfvar13</b> |       |                                                                                                                                         |
| vert_corr            | 2     | do not change                                                                                                                           |
| vertical_ip          | 0     | obsolete                                                                                                                                |
| vert_evalue          | 1     | do not change                                                                                                                           |
| max_vert_var1        | 99.0  | specify the maximum truncation value (percentage) to explain the variance of stream function in eigenvector decomposition               |
| max_vert_var2        | 99.0  | specify the maximum truncation value (percentage) to explain the variance of unbalanced potential velocity in eigenvector decomposition |
| max_vert_var3        | 99.0  | specify the maximum truncation value (percentage) to explain the variance of the unbalanced temperature in eigenvector decomposition    |
| max_vert_var4        | 99.0  | specify the maximum truncation value (percentage) to explain the variance of pseudo relative humidity in eigenvector decomposition      |
| max_vert_var5        | 99.0  | for unbalanced surface pressure, it should be a non-zero positive number.<br>set max_vert_var5=0.0 only for offline VarBC applications. |

**&wrfvar14**

the following 4 variables (rtm\_init\_nsensor, rtm\_init\_platform, rtm\_init\_satid, rtm\_init\_sensor) together control what sensors to be assimilated.

|                   |       |                                                                                                                                                            |
|-------------------|-------|------------------------------------------------------------------------------------------------------------------------------------------------------------|
| rtm_init_nsensor  | 1     | total number of sensors to be assimilated                                                                                                                  |
| rtm_init_platform | -1    | platforms IDs array (used dimension: (max_instruments) rtm_init_nsensor); e.g., 1 for NOAA, 9 for EOS, 10 for METOP and 2 for DMSP                         |
| rtm_init_satid    | -1.0  | satellite IDs array (used dimension: (max_instruments) rtm_init_nsensor)                                                                                   |
| rtm_init_sensor   | -1.0  | sensor IDs array (used dimension: (max_instruments) rtm_init_nsensor); e.g., 0 for HIRS, 3 for AMSU-A, 4 for AMSU-B, 15 for MHS, 10 for SSMIS, 11 for AIRS |
| rad_monitoring    | 0     | integer array (used dimension: rtm_init_nsensor); (max_instruments) 0: assimilating mode; 1: monitoring mode (only calculate innovations)                  |
| thinning_mesh     | 60.0  | real array (used dimension: rtm_init_nsensor); (max_instruments) specify thinning mesh size (in km) for different sensors.                                 |
| thinning          | false | .true.: perform thinning on radiance data                                                                                                                  |
| qc_rad            | true  | .true.: perform quality control. Do not change.                                                                                                            |

---

|                                   |                                  |                                                                                                                                                                                                                                                                         |
|-----------------------------------|----------------------------------|-------------------------------------------------------------------------------------------------------------------------------------------------------------------------------------------------------------------------------------------------------------------------|
| <code>write_iv_rad_ascii</code>   | <code>false</code>               | <code>.true.:</code> output radiance Observation minus Background files, which are in ASCII format and separated by sensor and processor.                                                                                                                               |
| <code>write_oa_rad_ascii</code>   | <code>false</code>               | <code>.true.:</code> output radiance Observation minus Analysis files (Observation minus Background information is also included), which are in ASCII format and separated by sensor and processor.                                                                     |
| <code>use_error_factor_rad</code> | <code>false</code>               | <code>.true.:</code> use a radiance error tuning factor file <code>radiance_error.factor</code> , which can be created with empirical values or generated using variational tuning method (Desroziers and Ivanov, 2001)                                                 |
| <code>use_antcorr</code>          | <code>false</code>               | <code>.true.:</code> perform Antenna Correction in CRTM                                                                                                                                                                                                                 |
|                                   | ( <code>max_instruments</code> ) |                                                                                                                                                                                                                                                                         |
| <code>rtm_option</code>           | <code>1</code>                   | which RTM (Radiative Transfer Model) to use (WRFDA must be compiled with the desired model included, see first section for details)<br>1: RTTOV<br>2: CRTM                                                                                                              |
| <code>only_sea_rad</code>         | <code>false</code>               | <code>.true.:</code> assimilate radiance over water only                                                                                                                                                                                                                |
| <code>use_varbc</code>            | <code>false</code>               | <code>.true.:</code> perform Variational Bias Correction. A parameter file in ASCII format called <code>VARBC.in</code> (a template is provided with the source code tar ball) is required.                                                                             |
| <code>freeze_varbc</code>         | <code>false</code>               | <code>.true.:</code> together with <code>use_varbc=false.</code> , keep the VarBC bias parameters constant in time. In this case, the bias correction is read and applied to the innovations, but it is not updated during the minimization.                            |
| <code>varbc_factor</code>         | <code>1.0</code>                 | for scaling the VarBC preconditioning                                                                                                                                                                                                                                   |
| <code>varbc_nobsmin</code>        | <code>10</code>                  | defines the minimum number of observations required for the computation of the predictor statistics during the first assimilation cycle. If there are not enough data (according to "VARBC_NOBSMIN") on the first cycle, the next cycle will perform a coldstart again. |
| <code>use_clddet_mmr</code>       | <code>false</code>               | <code>.true.:</code> use the MMR scheme to conduct cloud detection for infrared radiance                                                                                                                                                                                |
| <code>use_clddet_ecmwf</code>     | <code>false</code>               | <code>.true.:</code> use the ECMWF operational scheme to conduct cloud detection for infrared radiance.                                                                                                                                                                 |
| <code>airs_warmest_fov</code>     | <code>false</code>               | <code>.true.:</code> uses the observation brightness temperature for AIRS Window channel #914 as criterion for GSI thinning (with a higher amplitude than the distance from the observation location to the nearest grid point).                                        |

---

|                                                                                                                      |                       |                                                                                                                                                                                                                                                        |
|----------------------------------------------------------------------------------------------------------------------|-----------------------|--------------------------------------------------------------------------------------------------------------------------------------------------------------------------------------------------------------------------------------------------------|
| <code>use_crtm_kmatrix</code>                                                                                        | <code>false</code>    | .true. use CRTM K matrix rather than calling CRTM TL and AD routines for gradient calculation, which reduces runtime noticeably.                                                                                                                       |
| <code>use_rttov_kmatrix</code>                                                                                       | <code>false</code>    | .true. use RTTOV K matrix rather than calling RTTOV TL and AD routines for gradient calculation, which reduces runtime noticeably.                                                                                                                     |
| <code>rttov_emis_atlas_ir</code>                                                                                     | <code>0</code>        | 0: do not use IR emissivity atlas<br>1: use IR emissivity atlas (recommended)                                                                                                                                                                          |
| <code>rttov_emis_atlas_mw</code>                                                                                     | <code>0</code>        | 0: do not use MW emissivity atlas<br>1: use TELSEM MW emissivity atlas (recommended)<br>2: use CNRM MW emissivity atlas                                                                                                                                |
| <b>&amp;wrfvar15 (needs to be set together with &amp;wrfvar19)</b>                                                   |                       |                                                                                                                                                                                                                                                        |
| <code>num_pseudo</code>                                                                                              | <code>0</code>        | Set the number of pseudo observations, either 0 or 1 (single ob)                                                                                                                                                                                       |
| <code>pseudo_x</code>                                                                                                | <code>1.0</code>      | Set the x-position (I) of the OBS in unit of grid-point.                                                                                                                                                                                               |
| <code>pseudo_y</code>                                                                                                | <code>1.0</code>      | Set the y-position (J) of the OBS in unit of grid-point.                                                                                                                                                                                               |
| <code>pseudo_z</code>                                                                                                | <code>1.0</code>      | Set the z-position (K) of OBS with the vertical level index, in bottom-up order.                                                                                                                                                                       |
| <code>pseudo_val</code>                                                                                              | <code>1.0</code>      | Set the innovation of the ob; wind in m/s, pressure in Pa, temperature in K, specific humidity in kg/kg                                                                                                                                                |
| <code>pseudo_err</code>                                                                                              | <code>1.0</code>      | set the error of the pseudo ob. Unit the same as <code>pseudo_val</code> .; if <code>pseudo_var="q"</code> , <code>pseudo_err=0.001</code> is more reasonable.                                                                                         |
| <b>&amp;wrfvar16 (for hybrid WRFDA/ensemble)</b>                                                                     |                       |                                                                                                                                                                                                                                                        |
| <code>alphacv_method</code>                                                                                          | <code>2</code>        | 1: ensemble perturbations in control variable space<br>2: ensemble perturbations in model variable space                                                                                                                                               |
| <code>ensdim_alpha</code>                                                                                            | <code>0</code>        | ensemble size                                                                                                                                                                                                                                          |
| <code>alpha_corr_type</code>                                                                                         | <code>3</code>        | 1: <code>alpha_corr_type_exp</code><br>2: <code>alpha_corr_type_soar</code><br>3: <code>alpha_corr_type_gaussian</code> (default)                                                                                                                      |
| <code>alpha_corr_scale</code>                                                                                        | <code>1500.0</code>   | km                                                                                                                                                                                                                                                     |
| <b>&amp;wrfvar17</b>                                                                                                 |                       |                                                                                                                                                                                                                                                        |
| <code>analysis_type</code>                                                                                           | <code>"3D-VAR"</code> | "3D-VAR": 3D-VAR mode (default);<br>"QC-OBS": 3D-VAR mode plus extra filtered_obs output;<br>"VERIFY": verification mode. WRFDA resets <code>check_max_iv=.false.</code> and <code>ntmax=0</code> ;<br>"RANDOMCV": for creating ensemble perturbations |
| <code>adj_sens</code>                                                                                                | <code>false</code>    | .true.: write out gradient of Jo for adjoint sensitivity                                                                                                                                                                                               |
| <b>&amp;wrfvar18 (needs to set &amp;wrfvar21 and &amp;wrfvar22 as well if ob_format=1 and/or radiances are used)</b> |                       |                                                                                                                                                                                                                                                        |

---

---

analysis\_date "2002-08-03\_00:00:00.00" specify the analysis time. It should be consistent with the first guess time; however, if time difference between analysis\_date and date info read in from first guess is larger than analysis\_accu, WRFDA will issue a warning message ("=====> Wrong xb time found???"), but won't abort.

**&wrfvar19 (needs to be set together with &wrfvar15)**

pseudo\_var "t" Set the name of the OBS variable:  
'u' = X-direction component of wind,  
'v' = Y-direction component of wind,  
't' = Temperature,  
'p' = Pressure,  
'q' = Specific humidity  
"pw": total precipitable water  
"ref": refractivity  
"ztd": zenith total delay

**&wrfvar20**

documentation\_url "http://www.mm.ucar.edu/people/wrfhelp/wrfvar/code/trunk"

**&wrfvar21**

time\_window\_min "2002-08-02\_21:00:00.00" start time of assimilation time window used for ob\_format=1 and radiances to select observations inside the defined time\_window. Note: Start from V3.1, this variable is also used for ob\_format=2 to double-check if the obs are within the specified time window.

**&wrfvar22**

time\_window\_max "2002-08-03\_03:00:00.00" end time of assimilation time window used for ob\_format=1 and radiances to select observations inside the defined time\_window. Note: this variable is also used for ob\_format=2 to double-check if the obs are within the specified time window.

**&perturbation (settings related to the 4D-Var)**

jcdfi\_use false .true.: Include JcDF term in cost function.  
.false.: Ignore JcDF term in cost function.  
jcdfi\_diag 1 0: Doesn't print out the value of Jc.  
1: Print out the value of Jc.  
jcdfi\_penalty 10 The weight to Jc term.  
enable\_identity .false. .true.: use identity adjoint and tangent linear model in 4D-Var.  
.false.: use full adjoint and tangent linear model in 4D-Var.  
trajectory\_io .true. .true.: use memory I/O in 4D-Var for data exchange



---

|                  |       |                                                                                                            |
|------------------|-------|------------------------------------------------------------------------------------------------------------|
| var4d_detail_out | false | .false.: use disk I/O in 4D-Var for data exchange<br>.true.: output extra diagnostics for debugging 4D-Var |
|------------------|-------|------------------------------------------------------------------------------------------------------------|

OBSPROC namelist variables.

| Variable Names           | Description                                                                                                                             |
|--------------------------|-----------------------------------------------------------------------------------------------------------------------------------------|
| <b>&amp;record1</b>      |                                                                                                                                         |
| obs_gts_filename         | name and path of decoded observation file                                                                                               |
| fg_format                | 'MM5' for MM5 application, 'WRF' for WRF application                                                                                    |
| obserr.txt               | name and path of observational error file                                                                                               |
| first_guess_file         | name and path of the first guess file                                                                                                   |
| <b>&amp;record2</b>      |                                                                                                                                         |
| time_window_min          | The earliest time edge as ccyy-mm-dd_hh:mn:ss                                                                                           |
| time_analysis            | The analysis time as ccyy-mm-dd_hh:mn:ss                                                                                                |
| time_window_max          | The latest time edge as ccyy-mm-dd_hh:mn:ss                                                                                             |
|                          | ** Note : Only observations between [time_window_min, time_window_max] will kept.                                                       |
| <b>&amp;record3</b>      |                                                                                                                                         |
| max_number_of_obs        | Maximum number of observations to be loaded, i.e. in domain and time window, this is independent of the number of obs actually read.    |
| fatal_if_exceed_max_obs  | .TRUE.: will stop when more than max_number_of_obs are loaded<br>.FALSE.: will process the first max_number_of_obs loaded observations. |
| <b>&amp;record4</b>      |                                                                                                                                         |
| qc_test_vert_consistency | .TRUE. will perform a vertical consistency quality control check on sounding                                                            |
| qc_test_convective_adj   | .TRUE. will perform a convective adjustment quality control check on sounding                                                           |
| qc_test_above_lid        | .TRUE. will flag the observation above model lid                                                                                        |
| remove_above_lid         | .TRUE. will remove the observation above model lid                                                                                      |
| domain_check_h           | .TRUE. will discard the observations outside the domain                                                                                 |
| Thinning_SATOB           | .FALSE.: no thinning for SATOB data.<br>.TRUE.: thinning procedure applied to SATOB data.                                               |
| Thinning_SSMI            | .FALSE.: no thinning for SSMI data.<br>.TRUE.: thinning procedure applied to SSMI data.                                                 |
| Thinning_QSCAT           | .FALSE.: no thinning for SATOB data.<br>.TRUE.: thinning procedure applied to SSMI data.                                                |
| <b>&amp;record5</b>      |                                                                                                                                         |
| print_gts_read           | TRUE. will write diagnostic on the decoded obs reading in file obs_gts_read.diag                                                        |
| print_gpspw_read         | .TRUE. will write diagnostic on the gpsppw obs reading in file                                                                          |

---

|                      |                                                                                                                    |
|----------------------|--------------------------------------------------------------------------------------------------------------------|
| print_recoverp       | obs_gpspw_read.diag<br>.TRUE. will write diagnostic on the obs pressure recovery in file obs_recover_pressure.diag |
| print_duplicate_loc  | .TRUE. will write diagnostic on space duplicate removal in file obs_duplicate_loc.diag                             |
| print_duplicate_time | .TRUE. will write diagnostic on time duplicate removal in file obs_duplicate_time.diag                             |
| print_recoverh       | .TRUE. will write diagnostic on the obs height recovery in file obs_recover_height.diag                            |
| print_qc_vert        | .TRUE. will write diagnostic on the vertical consistency check in file obs_qc1.diag                                |
| print_qc_conv        | .TRUE. will write diagnostic on the convective adjustment check in file obs_qc1.diag                               |
| print_qc_lid         | .TRUE. will write diagnostic on the above model lid height check in file obs_qc2.diag                              |
| print_uncomplete     | .TRUE. will write diagnostic on the uncompleted obs removal in file obs_uncomplete.diag                            |
| user_defined_area    | .TRUE.: read in the record6: x_left, x_right, y_top, y_bottom,<br>.FALSE.: not read in the record6.                |

**&record6**

|                 |                                                                   |
|-----------------|-------------------------------------------------------------------|
| x_left          | West border of sub-domain, not used                               |
| x_right         | East border of sub-domain, not used                               |
| y_bottom        | South border of sub-domain, not used                              |
| y_top           | North border of sub-domain, not used                              |
| ptop            | Reference pressure at model top                                   |
| ps0             | Reference sea level pressure                                      |
| base_pres       | Same as ps0. User must set either ps0 or base_pres.               |
| ts0             | Mean sea level temperature                                        |
| base_temp       | Same as ts0. User must set either ts0 or base_temp.               |
| tlp             | Temperature lapse rate                                            |
| base_lapse      | Same as tlp. User must set either tlp or base_lapse.              |
| pis0            | Tropopause pressure, the default = 20000.0 Pa                     |
| base_tropo_pres | Same as pis0. User must set either pis0 or base_tropo_pres        |
| tis0            | Isothermal temperature above tropopause (K), the default = 215 K. |
| base_start_temp | Same as tis0. User must set either tis0 or base_start_temp.       |

**&record7**

|              |                                                                                                             |
|--------------|-------------------------------------------------------------------------------------------------------------|
| I PROJ       | Map projection (0 = Cylindrical Equidistance, 1 = Lambert Conformal, 2 = Polar stereographic, 3 = Mercator) |
| PHIC         | Central latitude of the domain                                                                              |
| XLONC        | Central longitude of the domain                                                                             |
| TRUELAT1     | True latitude 1                                                                                             |
| TRUELAT2     | True latitude 2                                                                                             |
| MOAD_CEN_LAT | The central latitude for the Mother Of All Domains                                                          |
| STANDARD_LON | The standard longitude (Y-direction) of the working domain.                                                 |

**&record8**

---

|        |                                                                                                                                                                                          |
|--------|------------------------------------------------------------------------------------------------------------------------------------------------------------------------------------------|
| IDD    | Domain ID (1=< ID =< MAXNES), Only the observations geographically located on that domain will be processed. For WRF application with XLONC /= STANDARD_LON, set IDD=2, otherwise set 1. |
| MAXNES | Maximum number of domains as needed.                                                                                                                                                     |
| NESTIX | The I(y)-direction dimension for each of the domains                                                                                                                                     |
| NESTJX | The J(x)-direction dimension for each of the domains                                                                                                                                     |
| DIS    | The resolution (in kilometers) for each of the domains. For WRF application, always set NESTIX(1),NESTJX(1), and DIS(1) based on the information in wrfinput.                            |
| NUMC   | The mother domain ID number for each of the domains                                                                                                                                      |
| NESTI  | The I location in its mother domain of the nest domain's low left corner -- point (1,1)                                                                                                  |
| NESTJ  | The J location in its mother domain of the nest domain's low left corner -- point (1,1). For WRF application, NUMC(1), NESTI(1), and NESTJ(1) are always set to be 1.                    |

**&record9**

|                           |                                                                                                        |
|---------------------------|--------------------------------------------------------------------------------------------------------|
| prepbuf_r_output_filename | Name of the PREPBUFR OBS file.                                                                         |
| prepbuf_r_table_filename  | 'prepbuf_r_table_filename'; do not change                                                              |
| output_ob_format          | output 1, PREPBUFR OBS file only;<br>2, ASCII OBS file only;<br>3, Both PREPBUFR and ASCII OBS files.  |
| use_for                   | '3DVAR' obs file, same as before, default<br>'FGAT ' obs files for FGAT<br>'4DVAR' obs files for 4DVAR |
| num_slots_past            | the number of time slots before time_analysis                                                          |
| num_slots_ahead           | the number of time slots after time_analysis                                                           |
| write_synop               | If keep synop obs in obs_gts (ASCII) files.                                                            |
| write_ship                | If keep ship obs in obs_gts (ASCII) files.                                                             |
| write_metar               | If keep metar obs in obs_gts (ASCII) files.                                                            |
| write_buoy                | If keep buoy obs in obs_gts (ASCII) files.                                                             |
| write_pilot               | If keep pilot obs in obs_gts (ASCII) files.                                                            |
| write_sound               | If keep sound obs in obs_gts (ASCII) files.                                                            |
| write_amdar               | If keep amdar obs in obs_gts (ASCII) files.                                                            |
| write_satem               | If keep satem obs in obs_gts (ASCII) files.                                                            |
| write_satob               | If keep satob obs in obs_gts (ASCII) files.                                                            |
| write_airep               | If keep airep obs in obs_gts (ASCII) files.                                                            |
| write_gpspw               | If keep gpspw obs in obs_gts (ASCII) files.                                                            |
| write_gpsztd              | If keep gpsztd obs in obs_gts (ASCII) files.                                                           |
| write_gpsref              | If keep gpsref obs in obs_gts (ASCII) files.                                                           |
| write_gpseph              | If keep gpseph obs in obs_gts (ASCII) files.                                                           |
| write_ssmt1               | If keep ssmt1 obs in obs_gts (ASCII) files.                                                            |
| write_ssmt2               | If keep ssmt2 obs in obs_gts (ASCII) files.                                                            |
| write_ssmi                | If keep ssmi obs in obs_gts (ASCII) files.                                                             |
| write_tovs                | If keep tovs obs in obs_gts (ASCII) files.                                                             |

|                          |                                               |
|--------------------------|-----------------------------------------------|
| <code>write_qscat</code> | If keep qscat obs in obs_gts (ASCII) files.   |
| <code>write_profl</code> | If keep profile obs in obs_gts (ASCII) files. |
| <code>write_bogus</code> | If keep bogus obs in obs_gts (ASCII) files.   |
| <code>write_airs</code>  | If keep airs obs in obs_gts (ASCII) files.    |